

A-A (1 : 9)

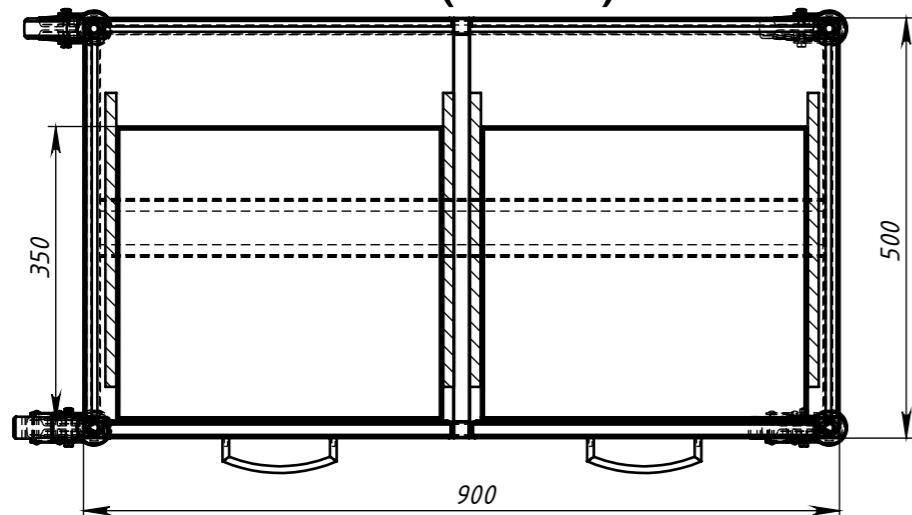

ПОЗИЦИЯ	ОБОЗНАЧЕНИЕ	ОПИСАНИЕ	ДЛИНА	К-ВО
1	Carcasa 900x500			1
1.1		Profil 25 X 25 X 1,2	842	4
1.2		ROUND ROD ϕ 8	450	4
1.3		ROUND ROD ϕ 8	850	2
1.4		TUBE ϕ 22 x 1,5	450	2
1.5				4
2	Polita 900x500 N1	S0,8		2
3	Ranfort 860	S0,8		2
4	sertar	S0,8		2
4.1	Fasad			1
4.2	Fasad sertarr			1
4.3	sertar			1
4.4	Miner			1
4.5	350x50x13 glesiere			2
5	Laterala	S 0,8		2
6	Spate	S0,8		1
7	Roata 100 cu frina			2
8	Roata 100 ff			2
9	suport			1
9.1		Profil 20 X 20 X 1,2	143	2
9.2		Profil 20 X 20 X 1,2	500	1
9.3		Profil 20 X 20 X 1,2	460	1
10	MirrorSpate			1

No	
Client	-
Inginer	Pleşivţev Artiom
Termen ex.	...2025

Carucior 900x500x850 cu 2 nivele si 2 sertar

METAL EXPERT
TECHNOLOGY