

HDB9 18mm Miniature Circuit Breaker

Standard: IEC/EN 60898-1





Function

HDB9 miniature circuit breakers combine the following functions:

- Protection of circuits against overload currents
- Protection of circuits against short-circuit currents
- Control
- Isolation

Order Information

Product	Breaking capacity	Frame	Poles	Tripping type	Rated current
HDB9	N	63A	2	C	16
	N:6kA H:10kA	63A	1:1P 2:2P 3:3P 4:4P 5: 1P+N 6: 3P+N	B:B Type C:C Type D:D Type	1:1A 2:2A ... 63:63A

Type	Breaking Capacity (kA)	Rating (A)	Width	Reference				
				B curve	C curve	D curve		
1P  2P 	6	1	2	HDB9N63A1B1	HDB9N63A1C1	HDB9N63A1D1		
		2	2	HDB9N63A1B2	HDB9N63A1C2	HDB9N63A1D2		
		4	2	HDB9N63A1B4	HDB9N63A1C4	HDB9N63A1D4		
		6	2	HDB9N63A1B6	HDB9N63A1C6	HDB9N63A1D6		
		10	2	HDB9N63A1B10	HDB9N63A1C10	HDB9N63A1D10		
		16	2	HDB9N63A1B16	HDB9N63A1C16	HDB9N63A1D16		
		20	2	HDB9N63A1B20	HDB9N63A1C20	HDB9N63A1D20		
		25	2	HDB9N63A1B25	HDB9N63A1C25	HDB9N63A1D25		
		32	2	HDB9N63A1B32	HDB9N63A1C32	HDB9N63A1D32		
		40	2	HDB9N63A1B40	HDB9N63A1C40	HDB9N63A1D40		
		50	2	HDB9N63A1B50	HDB9N63A1C50	HDB9N63A1D50		
		63	2	HDB9N63A1B63	HDB9N63A1C63	HDB9N63A1D63		
			10	1	2	HDB9H63A1B1	HDB9H63A1C1	HDB9H63A1D1
				2	2	HDB9H63A1B2	HDB9H63A1C2	HDB9H63A1D2
4	2			HDB9H63A1B4	HDB9H63A1C4	HDB9H63A1D4		
6	2			HDB9H63A1B6	HDB9H63A1C6	HDB9H63A1D6		
10	2			HDB9H63A1B10	HDB9H63A1C10	HDB9H63A1D10		
16	2			HDB9H63A1B16	HDB9H63A1C16	HDB9H63A1D16		
20	2			HDB9H63A1B20	HDB9H63A1C20	HDB9H63A1D20		
25	2			HDB9H63A1B25	HDB9H63A1C25	HDB9H63A1D25		
32	2			HDB9H63A1B32	HDB9H63A1C32	HDB9H63A1D32		
40	2			HDB9H63A1B40	HDB9H63A1C40	HDB9H63A1D40		
50	2			HDB9H63A1B50	HDB9H63A1C50	HDB9H63A1D50		
63	2			HDB9H63A1B63	HDB9H63A1C63	HDB9H63A1D63		



HDB9 18mm Miniature Circuit Breaker

Standard: IEC/EN 60898-1



Order Information

Type	Breaking Capacity (kA)	Rating (A)	Width	Reference				
				B curve	C curve	D curve		
1P+N	6	1	2	HDB9N63A5B1	HDB9N63A5C1	HDB9N63A5D1		
		2	2	HDB9N63A5B2	HDB9N63A5C2	HDB9N63A5D2		
		4	2	HDB9N63A5B4	HDB9N63A5C4	HDB9N63A5D4		
		6	2	HDB9N63A5B6	HDB9N63A5C6	HDB9N63A5D6		
		10	2	HDB9N63A5B10	HDB9N63A5C10	HDB9N63A5D10		
		16	2	HDB9N63A5B16	HDB9N63A5C16	HDB9N63A5D16		
		20	2	HDB9N63A5B20	HDB9N63A5C20	HDB9N63A5D20		
		25	2	HDB9N63A5B25	HDB9N63A5C25	HDB9N63A1D25		
		32	2	HDB9N63A5B32	HDB9N63A5C32	HDB9N63A5D32		
		40	2	HDB9N63A5B40	HDB9N63A5C40	HDB9N63A5D40		
		50	2	HDB9N63A5B50	HDB9N63A5C50	HDB9N63A5D50		
		63	2	HDB9N63A5B63	HDB9N63A5C63	HDB9N63A5D63		
		10	10	1	2	HDB9H63A5B1	HDB9H63A5C1	HDB9H63A5D1
				2	2	HDB9H63A5B2	HDB9H63A5C2	HDB9H63A5D2
4	2			HDB9H63A5B4	HDB9H63A5C4	HDB9H63A5D4		
6	2			HDB9H63A5B6	HDB9H63A5C6	HDB9H63A5D6		
10	2			HDB9H63A5B10	HDB9H63A5C10	HDB9H63A5D10		
16	2			HDB9H63A5B16	HDB9H63A5C16	HDB9H63A5D16		
20	2			HDB9H63A5B20	HDB9H63A5C20	HDB9H63A5D20		
25	2			HDB9H63A5B25	HDB9H63A5C25	HDB9H63A5D25		
32	2			HDB9H63A5B32	HDB9H63A5C32	HDB9H63A5D32		
40	2			HDB9H63A5B40	HDB9H63A5C40	HDB9H63A5D40		
50	2			HDB9H63A5B50	HDB9H63A5C50	HDB9H63A5D50		
63	2			HDB9H63A5B63	HDB9H63A5C63	HDB9H63A5D63		



HDB9 18mm Miniature Circuit Breaker

Standard: IEC/EN 60898-1

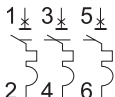

Order Information

Type	Breaking Capacity (kA)	Rating (A)	Width	Reference				
				B curve	C curve	D curve		
2P 	6	1	4	HDB9N63A2B1	HDB9N63A2C1	HDB9N63A2D1		
		2	4	HDB9N63A2B2	HDB9N63A2C2	HDB9N63A2D2		
		4	4	HDB9N63A2B4	HDB9N63A2C4	HDB9N63A2D4		
		6	4	HDB9N63A2B6	HDB9N63A2C6	HDB9N63A2D6		
		10	4	HDB9N63A2B10	HDB9N63A2C10	HDB9N63A2D10		
		16	4	HDB9N63A2B16	HDB9N63A2C16	HDB9N63A2D16		
		20	4	HDB9N63A2B20	HDB9N63A2C20	HDB9N63A2D20		
		25	4	HDB9N63A2B25	HDB9N63A2C25	HDB9N63A2D25		
		32	4	HDB9N63A2B32	HDB9N63A2C32	HDB9N63A2D32		
		40	4	HDB9N63A2B40	HDB9N63A2C40	HDB9N63A2D40		
		50	4	HDB9N63A2B50	HDB9N63A2C50	HDB9N63A2D50		
		63	4	HDB9N63A2B63	HDB9N63A2C63	HDB9N63A2D63		
		10	6	1	4	HDB9H63A2B1	HDB9H63A2C1	HDB9H63A2D1
				2	4	HDB9H63A2B2	HDB9H63A2C2	HDB9H63A2D2
4	4			HDB9H63A2B4	HDB9H63A2C4	HDB9H63A2D4		
6	4			HDB9H63A2B6	HDB9H63A2C6	HDB9H63A2D6		
10	4			HDB9H63A2B10	HDB9H63A2C10	HDB9H63A2D10		
16	4			HDB9H63A2B16	HDB9H63A2C16	HDB9H63A2D16		
20	4			HDB9H63A2B20	HDB9H63A2C20	HDB9H63A2D20		
25	4			HDB9H63A2B25	HDB9H63A2C25	HDB9H63A2D25		
32	4			HDB9H63A2B32	HDB9H63A2C32	HDB9H63A2D32		
40	4			HDB9H63A2B40	HDB9H63A2C40	HDB9H63A2D40		
50	4			HDB9H63A2B50	HDB9H63A2C50	HDB9H63A2D50		
63	4			HDB9H63A2B63	HDB9H63A2C63	HDB9H63A2D63		
3P 	6			1	6	HDB9N63A3B1	HDB9N63A3C1	HDB9N63A3D1
				2	6	HDB9N63A3B2	HDB9N63A3C2	HDB9N63A3D2
		4	6	HDB9N63A3B4	HDB9N63A3C4	HDB9N63A3D4		
		6	6	HDB9N63A3B6	HDB9N63A3C6	HDB9N63A3D6		
		10	6	HDB9N63A3B10	HDB9N63A3C10	HDB9N63A3D10		
		16	6	HDB9N63A3B16	HDB9N63A3C16	HDB9N63A3D16		
		20	6	HDB9N63A3B20	HDB9N63A3C20	HDB9N63A3D20		
		25	6	HDB9N63A3B25	HDB9N63A3C25	HDB9N63A3D25		
		32	6	HDB9N63A3B32	HDB9N63A3C32	HDB9N63A3D32		
		40	6	HDB9N63A3B40	HDB9N63A3C40	HDB9N63A3D40		
		50	6	HDB9N63A3B50	HDB9N63A3C50	HDB9N63A3D50		
		63	6	HDB9N63A3B63	HDB9N63A3C63	HDB9N63A3D63		

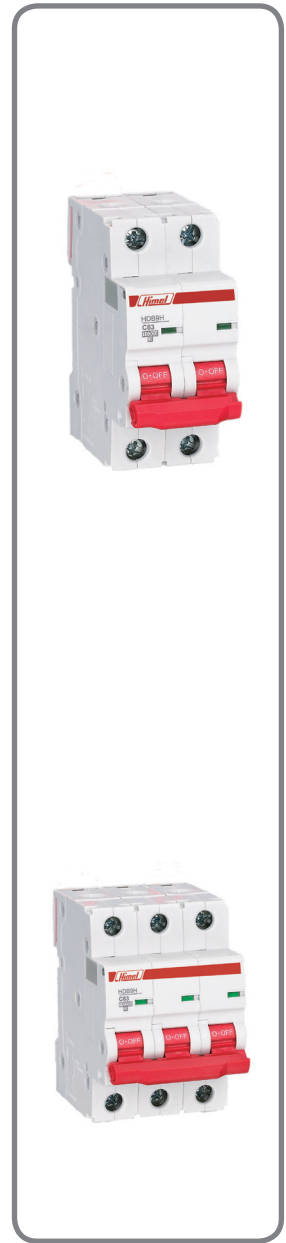

Final Distribution



HDB9 18mm Miniature Circuit Breaker

Standard: IEC/EN 60898-1



Order Information

Type	Breaking Capacity (kA)	Rating (A)	Width	Reference		
				B curve	C curve	D curve
	10	1	6	HDB9H63A3B1	HDB9H63A3C1	HDB9H63A3D1
		2	6	HDB9H63A3B2	HDB9H63A3C2	HDB9H63A3D2
		4	6	HDB9H63A3B4	HDB9H63A3C4	HDB9H63A3D4
		6	6	HDB9H63A3B6	HDB9H63A3C6	HDB9H63A3D6
		10	6	HDB9H63A3B10	HDB9H63A3C10	HDB9H63A3D10
		16	6	HDB9H63A3B16	HDB9H63A3C16	HDB9H63A3D16
		20	6	HDB9H63A3B20	HDB9H63A3C20	HDB9H63A3D20
		25	6	HDB9H63A3B25	HDB9H63A3C25	HDB9H63A3D25
		32	6	HDB9H63A3B32	HDB9H63A3C32	HDB9H63A3D32
		40	6	HDB9H63A3B40	HDB9H63A3C40	HDB9H63A3D40
		50	6	HDB9H63A3B50	HDB9H63A3C50	HDB9H63A3D50
		63	6	HDB9H63A3B63	HDB9H63A3C63	HDB9H63A3D63
		3P+N	6	1	2	HDB9N63A6B1
2	2			HDB9N63A6B2	HDB9N63A6C2	HDB9N63A6D2
4	2			HDB9N63A6B4	HDB9N63A6C4	HDB9N63A6D4
6	2			HDB9N63A6B6	HDB9N63A6C6	HDB9N63A6D6
10	2			HDB9N63A6B10	HDB9N63A6C10	HDB9N63A6D10
16	2			HDB9N63A6B16	HDB9N63A6C16	HDB9N63A6D16
20	2			HDB9N63A6B20	HDB9N63A6C20	HDB9N63A6D20
25	2			HDB9N63A6B25	HDB9N63A6C25	HDB9N63A6D25
32	2			HDB9N63A6B32	HDB9N63A6C32	HDB9N63A6D32
40	2			HDB9N63A6B40	HDB9N63A6C40	HDB9N63A6D40
50	2			HDB9N63A6B50	HDB9N63A6C50	HDB9N63A6D50
63	2			HDB9N63A6B63	HDB9N63A6C63	HDB9N63A6D63
	10			1	8	HDB9H63A6B1
		2	8	HDB9H63A6B2	HDB9H63A6C2	HDB9H63A6D2
		4	8	HDB9H63A6B4	HDB9H63A6C4	HDB9H63A6D4
		6	8	HDB9H63A6B6	HDB9H63A6C6	HDB9H63A6D6
		10	8	HDB9H63A6B10	HDB9H63A6C10	HDB9H63A6D10
		16	8	HDB9H63A6B16	HDB9H63A6C16	HDB9H63A6D16
		20	8	HDB9H63A6B20	HDB9H63A6C20	HDB9H63A6D20
		25	8	HDB9H63A6B25	HDB9H63A6C25	HDB9H63A6D25
		32	8	HDB9H63A6B32	HDB9H63A6C32	HDB9H63A6D32
		40	8	HDB9H63A6B40	HDB9H63A6C40	HDB9H63A6D40
		50	8	HDB9H63A6B50	HDB9H63A6C50	HDB9H63A6D50
		63	8	HDB9H63A6B63	HDB9H63A6C63	HDB9H63A6D63

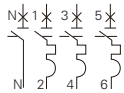

HDB9 18mm Miniature Circuit Breaker

Standard: IEC/EN 60898-1



Order Information

Type	Breaking Capacity (kA)	Rating (A)	Width	Reference				
				B curve	C curve	D curve		
4P 1 3 5 7 2 4 6 8	6	1	8	HDB9N63A4B1	HDB9N63A4C1	HDB9N63A4D1		
		2	8	HDB9N63A4B2	HDB9N63A4C2	HDB9N63A4D2		
		4	8	HDB9N63A4B4	HDB9N63A4C4	HDB9N63A4D4		
		6	8	HDB9N63A4B6	HDB9N63A4C6	HDB9N63A4D6		
		10	8	HDB9N63A4B10	HDB9N63A4C10	HDB9N63A4D10		
		16	8	HDB9N63A4B16	HDB9N63A4C16	HDB9N63A4D16		
		20	8	HDB9N63A4B20	HDB9N63A4C20	HDB9N63A4D20		
		25	8	HDB9N63A4B25	HDB9N63A4C25	HDB9N63A4D25		
		32	8	HDB9N63A4B32	HDB9N63A4C32	HDB9N63A4D32		
		40	8	HDB9N63A4B40	HDB9N63A4C40	HDB9N63A4D40		
		50	8	HDB9N63A4B50	HDB9N63A4C50	HDB9N63A4D50		
		63	8	HDB9N63A4B63	HDB9N63A4C63	HDB9N63A4D63		
			10	1	8	HDB9H63A4B1	HDB9H63A4C1	HDB9H63A4D1
				2	8	HDB9H63A4B2	HDB9H63A4C2	HDB9H63A4D2
4	8			HDB9H63A4B4	HDB9H63A4C4	HDB9H63A4D4		
6	8			HDB9H63A4B6	HDB9H63A4C6	HDB9H63A4D6		
10	8			HDB9H63A4B10	HDB9H63A4C10	HDB9H63A4D10		
16	8			HDB9H63A4B16	HDB9H63A4C16	HDB9H63A4D16		
20	8			HDB9H63A4B20	HDB9H63A4C20	HDB9H63A4D20		
25	8			HDB9H63A4B25	HDB9H63A4C25	HDB9H63A4D25		
32	8			HDB9H63A4B32	HDB9H63A4C32	HDB9H63A4D32		
40	8			HDB9H63A4B40	HDB9H63A4C40	HDB9H63A4D40		
50	8			HDB9H63A4B50	HDB9H63A4C50	HDB9H63A4D50		
63	8			HDB9H63A4B63	HDB9H63A4C63	HDB9H63A4D63		



HDB9 18mm Miniature Circuit Breaker

Standard: IEC/EN 60898-1



Technical Data

MCB	HDB9 18mm Circuit Breaker			
Electrical Features	Standard	IEC/EN 60898-1		
	Certification	KEMA CB CE RoHS		
	Poles	1P, 1P+N, 2P, 3P, 3P+N, 4P		
	Rated Current In	1, 2, 4, 6, 10, 16, 20, 25, 32, 40, 50, 63A		
	Rated Voltage Ue	1P: 230/400V AC; 1P+N: 230V AC, 2P, 3P, 3P+N, 4P: 400V AC		
	Insulation Voltage Ui	500V		
	Frequency	50/60Hz		
	Energy limiting class	3(1P, 2P, 3P, 4P) 1(1P+N, 3P+N)		
	Breaking Capacity Icn	6kA, 10kA		
Tripping Curve	B, C, D			
Mechanical Features	Electrical Durability	10000 times		
	Mechanical Durability	20000 times		
	Protection Degree	IP20		
	Operating Temperature	-30°C ~ +70°C		
Connection	1-63A 25mm ²			
Installation	Rated Current(A)	Screw	Rated Torque (N•m)	Maximum Ultimate Torque(N•m)
	1-63A	M5	2.0	2.5
Mounting	35mm Din-rail			
Accessories	Contact Accessory	OF		
	Fault-indicating Accessories	SD		
	Shunt -trip release	MX+OF		

HDB9 18mm Miniature Circuit Breaker

Standard: IEC/EN 60898-1



Tripping Curve

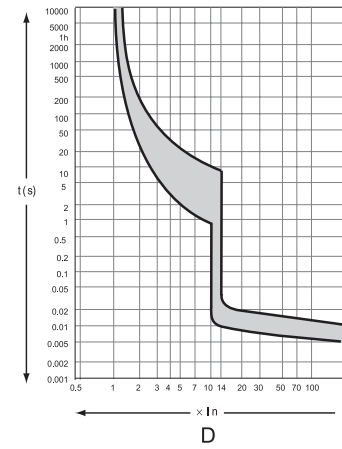
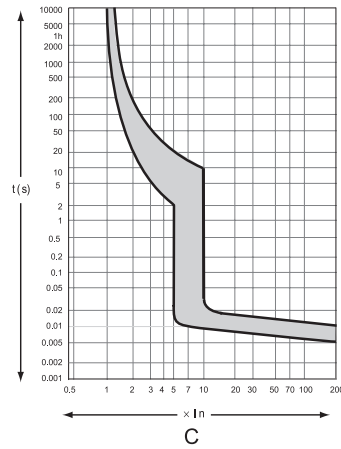
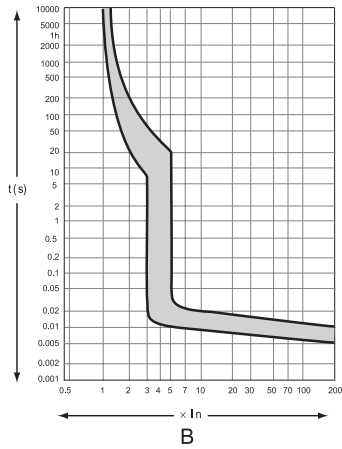

HDB9 18mm Miniature Circuit Breaker

Standard: IEC/EN 60898-1



Overall Dimensions

Unit: mm

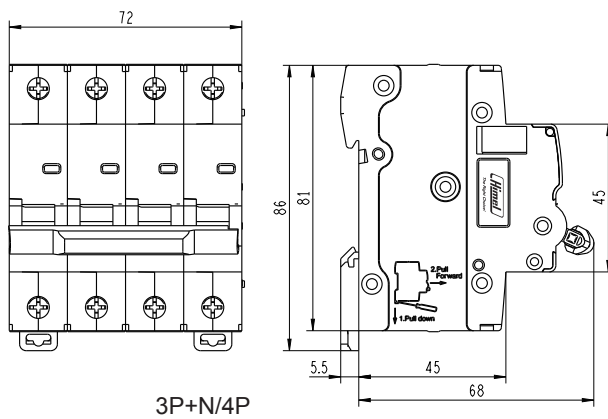
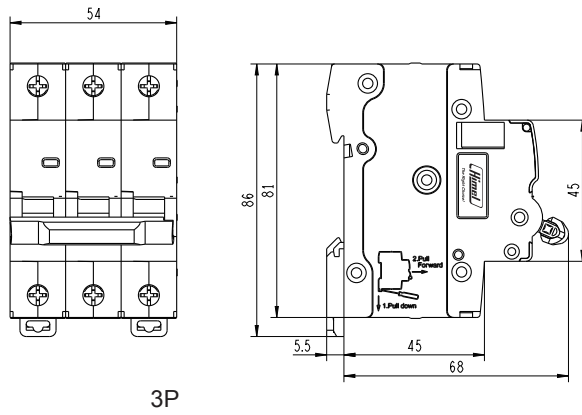
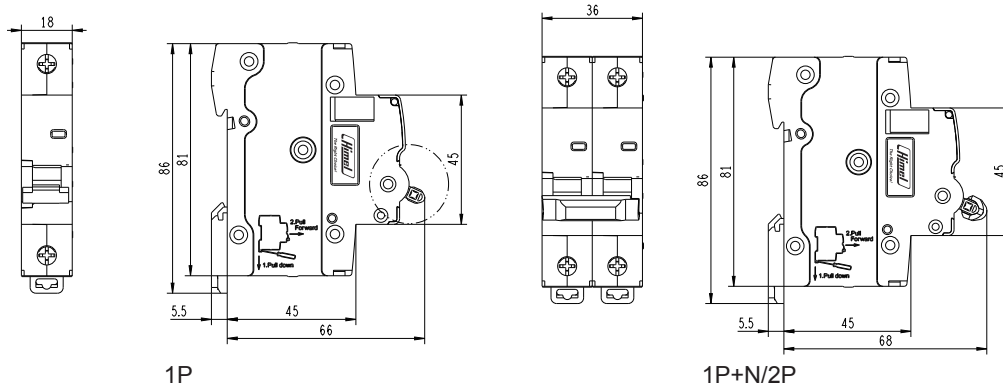

HDB9 18mm Miniature Circuit Breaker

Standard: IEC/EN 60898-1



Accessories

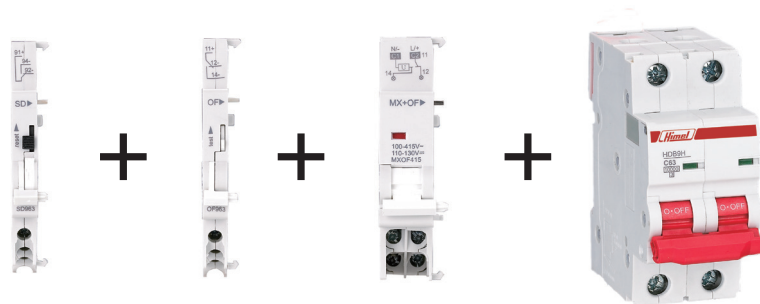

Final Distribution

