

# Atlas Copco

## Oil-injected rotary screw air compressors

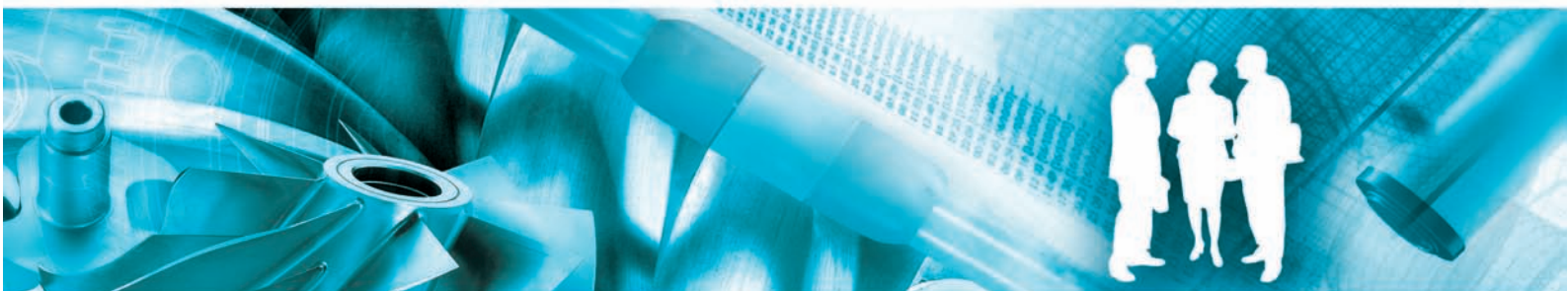

GA 15, GA 18, GA 22

### Parts list





# Atlas Copco

## Oil-injected rotary screw air compressors

GA 15, GA 18, GA 22

From following serial No. onwards :  
API 459 000

### Parts list

- Copyright 2009, Atlas Copco Airpower n.v., Antwerp, Belgium.  
Any unauthorized use or copying of the contents or any part thereof is prohibited.  
This applies in particular to trademarks, model denominations, part numbers and drawings.
- **Use only authorized parts.** Any damage or malfunction caused by the use of unauthorized parts is not covered by Warranty or Product Liability.

2009 - 04

No. 2930 7084 50

[www.atlascopco.com](http://www.atlascopco.com)

The Atlas Copco logo consists of the brand name "Atlas Copco" in a stylized, italicized serif font. It is positioned between two thick, solid black horizontal bars, one above and one below the text.

## EN - INSTRUCTIONS FOR USE

### 1 ORDERING PARTS

Always specify the part number, the name and quantity of the required items, as well as the type and serial number of the machine.  
Pages marked with Service symbol -  contain parts of Service kit(s). For complete contents of the kit see chapter "1 - Service kits".

### 2 COLUMN INFORMATION

**Ref.** - Reference number: links a specific listed part to the drawing. Only parts with a reference number are shown in the drawing. Parts in the drawing without a reference number are simply there to illustrate the assembly.

**Part number** - Part number: if no part number is specified, the component is not available as a spare part. A line shown in bold is an assembly. A part of which the number is followed by a black dot is comprised in the bold printed assembly right above.

"<<< >>>" Directs to another list with the same title as the "Name".

When the part number of the specific parts is placed below the "Ref./Name" line a choice must be made upon the type/version of the machine.

**Qty** - Quantity: indicates the number of parts in connection with the corresponding reference number. „AR“ means „As required“: quantity or number to be determined.

**Name** - Part name: translations of the English names can be found in document "Glossary of part names".

**Remarks** - Extra information about the part.

A series of letters can indicate that a particular part has been certified by the specified authorized body, in accordance with the codes or rules of the list.

Measurements are given in millimeters.

## BG - ИНСТРУКЦИИ ЗА ИЗПОЛЗВАНЕ

### 1 ЗАЯВЯВАНЕ НА РЕЗЕРВНИ ЧАСТИ

Винаги указвайте номера на частта, наименованието и необходимото количество от артикула, както и модела и серийния номер на машината.

Страниците, маркирани със символ за сервиз -  , съдържат части от Сервизен комплект(и). За пълното съдържание на комплекта вж. глава "1 - Service kits" (1 - Сервизни комплекти).

### 2 ЗНАЧЕНИЕ НА КОЛОНИТЕ

**Ref.** - Цифрово обозначение: връзка с чертежа за определена част от спецификацията. На чертежа са показани само детайли с цифрово обозначение. Детайлите без цифрово обозначение в чертежа са показани само за прегледност на сглобената единица.

**Part number** - Номер на частта: ако не е указан такъв, детайлът не се предлага като резервна част. Удебелена линия означава сглобена единица. Част, чийто номер е последван от черна точка, се съдържа в сглобената единица, отпечатана точно отгоре с получер шрифт.

"<<< >>>" е указател към друга спецификация със същото наименование като "Name".

Когато номерът на частта на указания детайл е разположен под реда "Ref./Name", трябва да се направи избор съобразно модела/версията на машината.

**Qty** - Количество: указва броя детайли, свързани със съответното цифрово обозначение. "Заявка" означава "По заявка": количество или бройка за доуточняване.

**Name** - Наименование на частта: преводите на английските наименования могат да бъдат намерени в документа "Речник на наименованията на частите".

**Remarks** - Допълнителна информация за частта.

Поредица от букви може да указва, че определен детайл е сертифициран от посочения упълномощен орган за съответствие с параметрите или правилата в спецификацията.

Всички стойности са дадени в милиметри.

## BR - INSTRUÇÕES DE USO

### 1 ENCOMENDANDO PEÇAS

Sempre especifique o número da peça, o nome e a quantidade dos itens necessários, assim como o tipo e o número de série da máquina.

Páginas marcadas com o símbolo Serviço -  - contém peças do(s) Kit(s) de serviço. Para conhecer o conteúdo completo do kit, consulte o capítulo "1 - Service kits" (1 - Kits de serviço).

### 2 INFORMAÇÕES SOBRE AS COLUNAS

**Ref.** - Número de referência: indica onde está uma peça específica listada no desenho. Somente peças com número de referência são mostradas no desenho. As peças no desenho que não têm um número de referência destinam-se simplesmente a ilustrar o conjunto.

**Part number** - Número da peça: se nenhum número de peça estiver especificado, o componente não está disponível como peça sobressalente. Uma linha mostrada em negrito é um conjunto. Uma peça cujo número seja seguido por um ponto preto faz parte do conjunto impresso em negrito imediatamente acima dela.

O símbolo "<<< >>>" direciona para outra lista com o mesmo título, como "Name" (Nome).

Quando o número de peça específico é colocado abaixo da linha "Ref./Name" (Ref. / Nome), é preciso escolher o tipo/versão da máquina.

**Qty** - Quantidade: indica o número de peças e os números de referência correspondentes. "AR" significa "As required" (Conforme solicitado): a quantidade ou o número a ser determinado.

**Name** - Nome da peça: as traduções dos nomes em inglês podem ser encontradas no documento "Glossary of part names" (Glossário de nomes de peças).

**Remarks** - Observações - Informações extras sobre a peça.

Uma série de letras pode indicar que uma determinada peça é certificada pelo órgão autorizado específico, de acordo com os códigos ou as regras da lista.

As medidas são fornecidas em milímetros.

## CS - NÁVOD K POUŽITÍ

### 1 OBJEDNÁNÍ DÍLŮ

Vždy uveďte přesné číslo dílu, název a množství požadovaných položek, a také typ a sériové číslo stroje.

Stránky označené symbolem servisu -  obsahují součásti servisní sady (servisních sad). Kompletní obsah sady naleznete v kapitole "1 - Service kits" (1, Servisní sady).

### 2 INFORMACE VE SLOUPCÍCH

**Ref.** - Referenční číslo: odkazuje díl uvedený v seznamu k místu ve výkresu. Ve výkresu jsou uvedeny pouze díly s referenčním číslem. Díly bez referenčního čísla, které jsou ve výkresu uvedeny, slouží pouze jako ilustrace.

**Part number** - Číslo dílu: pokud není uvedeno číslo dílu, component se jako náhradní díl nedodává. Řádek tučně je sestava. Díl, jehož číslo je následováno černou tečkou, je součástí sestavy, jejíž název je vtištěn tučně výše.

"<<< >>>" vede na další seznam se stejným názvem, jaký je uveden v poli „Name“ (Název dílu).

Pokud je pod řádkem „Ref./Name“ umístěno číslo dílu konkrétního dílu, musí být proveden výběr typu/verze stroje.

**Qty** - Množství: uvádí počet dílů spojených s příslušným referenčním číslem. „AR“ znamená „As required“ (podle požadavků): množství nebo číslo, které má být určeno.

**Name** - Název dílu: překlad anglického názvu lze najít v dokumentu „Rejstřík názvů dílů“.

**Remarks** - Doplnkové informace k dílu.

Série písmen může označovat, že určitý díl byl certifikován autorizovanou osobou v souladu s kódy a pravidly seznamu.

Rozměry jsou uvedeny v milimetrech.



## DA - ANVENDELSESINSTRUKTIONER

### 1 BESTILLING AF RESERVEDELE

Angiv altid reservedelsnummer, navn og antal for de dele, du ønsker, samt maskinens typebetegnelse og serienummer.

Sider markeret med servicesymbolet -  indeholder dele af service-kittet(ene). For et samlet overblik over kittets indhold, se kapitel "1 - Service kits"(1 - Service kits).

### 2 FORKLARING TIL SPALTER

**Ref.** - Referencenummer: knytter en specifik del på listen til tegningen. På tegningen vises kun reservedele, som har et referencenummer. Reservedele på tegningen, som ikke har et referencenummer, er medtaget for illustrationens skyld.

**Part number.** - Reservedelsnummer: hvis der ikke er angivet noget reservedelsnummer, fås den pågældende komponent ikke som reservedel. En linje, som vises med fed skrift, er en samling af dele. En reservedel, hvor nummeret er efterfulgt af en sort prik, er en af de dele, der indgår i samlingen af dele, som vises med fed skrift ovenover.

"<<< >>>" henviser til en anden liste med samme titel som "Name".

Når den specifikke reservedelsnummer placeres under linjen "Ref./Name", skal du vælge type/version for maskinen.

**Qty** - Antal: angiver antallet af reservedele, der indgår i det tilsvarende referencenummer. "AR" betyder "As required" (som krævet): mængde eller antal skal bestemmes.

**Name** - Reservedelsnavn: oversættelse af de engelske navne kan findes i dokumentet "Liste over reservedelsnavne".

**Remarks** - Ekstra information om reservedelen.

En bogstavrække kan angive, at en bestemt reservedel er blevet certificeret af det pågældende godkendende organ, i henhold til standarderne på listen.

Alle mål er angivet i millimeter.

## DE - BEDIENUNGSANWEISUNG

### 1 BESTELLEN VON TEILEN

Immer Teilenummer, Bezeichnung und Anzahl der erforderlichen Teile sowie Typ und Seriennummer der Maschine angeben.

Seiten mit dem Servicesymbol -  enthalten Teile von Service-Kit(s). Informationen zum vollständigen Inhalt des Kits finden Sie im Kapitel „1 - Service kits“ (1 - Service-Kits).

### 2 ERLÄUTERUNG DER SPALTEN

**Ref.** - Referenznummer: Querverweis zwischen einem aufgeführten Teil und der Zeichnung. In der Zeichnung sind nur Teile mit einer Referenznummer abgebildet. Abgebildete Teile ohne Referenznummer dienen lediglich der Darstellung der Baugruppe.

**Part number** - Teilenummer: Falls keine Teilenummer angegeben ist, ist das Bauteil nicht als Ersatzteil lieferbar. Baugruppen sind fett hervorgehoben. Wenn sich hinter einer Teilenummer ein schwarzer Punkt befindet, gehört dieses Teil zur darüber stehenden Baugruppe.

"<<< >>>" bedeutet, daß Sie eine andere Liste nachschlagen müssen.

Steht die Teilnummer unter der Ref./Name Zeile, so muß eine Wahl gemacht werden je nach Typ/Ausführung der Maschine.

**Qty** - Anzahl: Gib die Anzahl der Teile in Bezug auf die entsprechende Referenznummer an. „AR“ steht für „As required“ (nach Bedarf), die gewünschte Anzahl muss angegeben werden.

**Name** - Teilebezeichnung: Eine Übersetzung der englischen Bezeichnungen finden Sie im Dokument "Glossary of part names" (Glossar Teilebezeichnungen).

**Remarks** - Zusätzliche Information zu dem Teil.

Eine Buchstabenfolge weist darauf hin, dass ein bestimmtes Teil durch die angegebene zuständige Stelle gemäß den aufgeführten Normen und Richtlinien zertifiziert wurde.

Abmessungen sind in Millimetern angegeben.

## EL - ΟΔΗΓΙΕΣ ΧΡΗΣΗΣ

### 1 ΠΑΡΑΓΓΕΛΙΑ ΑΝΤΑΛΛΑΚΤΙΚΩΝ

Να προσδιορίζετε πάντοτε τον κωδικό είδους, την περιγραφή και την ποσότητα των αιτούμενων ειδών καθώς, επίσης, και τον τύπο και τον αριθμό σειράς του μηχανήματος.

Οι σελίδες που επισημειώνονται με το σύμβολο Σέρβις-  περιέχουν μέρη από Πακέτα ανταλλακτικών συντήρησης. Για το πλήρες περιεχόμενο του πακέτου, ανατρέξτε στο κεφάλαιο "1 - Service kits" (1 - Πακέτα ανταλλακτικών συντήρησης).

### 2 ΠΛΗΡΟΦΟΡΙΕΣ ΓΙΑ ΤΗ ΣΥΜΠΛΗΡΩΣΗ ΤΩΝ ΣΤΗΛΩΝ

**Ref.** - Κωδικός αναφοράς: συνδέει ένα συγκεκριμένο λειτουργικό εξάρτημα του καταλόγου με το σχέδιο. Στο σχέδιο εμφανίζονται μόνο εξαρτήματα που διαθέτουν κωδικό αναφοράς. Τα εξαρτήματα του σχεδίου που δε διαθέτουν κωδικό αναφοράς απλά εμφανίζονται για την πληρέστερη περιγραφή του συγκροτήματος.

**Part number** - Κωδικός είδους: εάν δεν προσδιορίζεται κωδικός είδους, το εξάρτημα δεν είναι διαθέσιμο ως ανταλλακτικό. Γραμμές που εμφανίζονται με έντονη γραφή αντιστοιχούν σε συγκροτήματα. Ένα εξάρτημα του οποίου ο κωδικός ακολουθείται από μαύρη τελεία περιλαμβάνεται στο αμέσως παραπάνω συγκρότημα που εμφανίζεται με έντονη γραφή.

Το "<<< >>>" αποτελεί αναφορά σε άλλο κατάλογο με τον τίτλο που αναγράφεται στην ένδειξη "Name".

Όταν ο κωδικός είδους του προσδιοριζόμενου εξαρτήματος βρίσκεται κάτω από τη γραμμή "Ref./Name", θα πρέπει να γίνει επιλογή του τύπου/έκδοσης του μηχανήματος.

**Qty** - Ποσότητα: υποδεικνύει το πλήθος των εξαρτημάτων που ζητούνται από τον αντίστοιχο κωδικό αναφοράς. "AR" σημαίνει "As required" (Σύμφωνα με τις απαιτήσεις): ποσότητα ή πλήθος προς προσδιορισμό.

**Name** - Περιγραφή είδους: μεταφράσεις των αγγλικών ονομασιών περιέχονται στο έντυπο "Γλωσσάριο εξαρτημάτων".

**Remarks** - Πρόσθετες πληροφορίες σχετικά με ένα ανταλλακτικό.

Η ύπαρξη μιας σειράς γραμμάτων υποδεικνύει ότι ένα συγκεκριμένο ανταλλακτικό διαθέτει έγκριση από τον αναφερόμενο εξουσιοδοτημένο φορέα, σύμφωνα με τους κώδικες ή τους κανονισμούς του καταλόγου.

Οι διαστάσεις αναφέρονται σε χιλιοστάμετρα.

## ES - INSTRUCCIONES DE USO

### 1 PEDIDO DE PIEZAS

Especifique siempre la designación, el nombre y la cantidad de las piezas deseadas, así como el tipo y el número de serie de la máquina.

Las páginas marcadas con el símbolo de Servicio -  contienen piezas de kit(s) de servicio. Para el contenido completo del kit, vea el capítulo "1 - Service kits" (1 - Kits de servicio).

### 2 INFORMACIÓN DE LAS COLUMNAS

**Ref.** - Número de referencia: establece un vínculo entre una pieza específica de la lista y el dibujo. Sólo las piezas con número de referencia aparecen en el dibujo. Las piezas que aparecen sin número de referencia sólo se muestran en el dibujo para ilustrar el conjunto.

**Part number** - Designación: si no se indica ninguna designación, el componente no se encuentra disponible como pieza de repuesto. Los conjuntos aparecen con una línea en negrita. Las piezas con números seguidos por un punto negro, indican que forman parte del conjunto que aparece en negrita anteriormente.

"<<< >>>" dirige a otra lista con el mismo título que el "Name".

Cuando la designación de una pieza específica está situada debajo de la línea "Ref./Name" se debe elegir el tipo/version de la máquina.

**Qty** - Cantidad: indica la cantidad de piezas asociadas al número de referencia correspondiente. "AR" significa "As required" (según se requiera): debe determinarse la cantidad o el número.

**Name** - Nombre de la pieza: las traducciones de los nombres en inglés se encuentran en el documento "Glosario de nombres de piezas".

**Remarks** - Observaciones: información adicional sobre las piezas.

Una serie de letras puede indicar que una pieza específica ha sido certificada por la entidad autorizada indicada, conforme a los códigos o reglas especificados.

Las dimensiones se expresan en milímetros.

## ET - KASUTUSJUHISED

### 1 OSADE TELLIMINE

Määrake alati osa number, vajalike osade nimed ja kogused, samuti masina tüüp ja seerianumber.

Hooldussümboliga tähistatud leheküljed -  sisaldavad hoolduskomplekti(-de) osi. Komplekti täieliku sisu jaoks vt peatükki "1 - Service kits" (1 - Hoolduskomplektid).

### 2 VEERUTEAVE

**Ref.** viitenumber seostab konkreetse nimistus oleva osa vastava joonisega. Joonisel on toodud ainult viitenumbriga osad. Joonisel olevad viitenumbriga osad on mõeldud ainult illustreerimiseks.

**Part number:** osa number. Kui osa number pole määratud, siis pole see komponent varuosana saadaval. Rasvane joon tähistab seadet. Osa, millele järgneb must punkt, koosneb paremal üleval rasvaselt trükitud koostisest.

„<<< >>>” viib teise loendini, millel on samasugune pealkiri kui „Nimi”.

Kui osa number või konkreetne osa on paigutatud „Viite”/„Nime” joone alla, tuleb valida seadme tüüp/version.

**Qty:** kogus näitab vastava viitenumbriga tähistatud osade arvu. „AR” tähendab „As required” (Vastavalt vajadusele): määratletakse kas kogus või number.

**Name** ehk osa nimi: ingliskeelsete nimede tõlked leiata dokumentidest „Osa nimede sõnastik”.

**Remarks** – osa kohta käiv lisateave.

Tähtede seeria võib näidata, et mingi osa on vastavalt nimekirja koodidele või reeglitele volitatud organist sertifitseeritud.

Mõõtmel on millimeetrites.

## FI - KÄYTTÖOHJEET

### 1 OSIEN TILAAMINEN

Mainitse aina osan numero, haluttujen osien nimitykset ja määrät, sekä koneen malli ja valmistusnumero.

Houtosymbolilla -  merkityillä sivuilla on huoltotarvikesarjojen osia. Katso sarjan täydellinen sisältö luvusta "1 - Service kits" (1 - Huoltotarvikesarjat).

### 2 SARAKKEIDEN SELITYKSET

**Ref.** - Viitenumber: Viittaa osaan luettelossa ja piirustuksessa. Vain osat, joilla on viitenumber, näkyvät piirustuksessa. Ilman viitenumeroa piirustuksessa olevien osien tarkoituksena on vain selkeyttää kokonaisuutta.

**Part number** - Osanumber: Jos osanumeroa ei ole ilmoitettu, osaa ei ole saatavana varaosana. Lihavoituna näkyvä rivi on kokonaisuus. Osa, jonka numeroa seuraa musta piste, sisältyy lähinnä ylhäällä lihavoidulla painettuun tarvikesarjaan.

“<<< >>>” kehottaa katsomaan toista luetteloa, jonka "Name"-otsikko on sama.

Kun tietyn osan osanumber on "Ref."/"Name"-viivan alapuolella, on valittava koneen tyyppi/version.

**Qty** - Määrä: Ilmoittaa viitenumeroon liittyvien osien määrän. "AR" tarkoittaa "As required" (tarpeen mukaan): irtotavaraa tai määrää on selvitettävä.

**Name** - Osanimi: englanninkielisten osanimien käännökset löytyvät painotuohteesta Osien nimien sanasto.

**Remarks** - Lisätieto osasta.

Kirjainyhdistelmä voi ilmoittaa, että mainittu valtuutettu elin on hyväksynyt osan luettelon koodien tai sääntöjen mukaisesti.

Mitat on annettu millimetreinä.

## FR - INSTRUCTIONS D'UTILISATION

### 1 COMMANDE DE PIÈCES DÉTACHÉES

Précisez toujours le numéro de pièce, la désignation et la quantité de composants souhaitée, ainsi que le type et le numéro de série de la machine.

Les pages sur lesquelles figure le symbole d'entretien -  traitent de pièces comprises dans un/des kit(s) d'entretien. Pour le contenu complet du kit, voir le chapitre "1 - Service kits" (1 - Kits d'entretien).

### 2 INFORMATIONS DISPONIBLES DANS LES COLONNES

**Ref.** - Numéro de référence : se réfère à une pièce particulière dans la liste et le schéma. Seules les pièces auxquelles un numéro de référence a été attribué sont représentées sur le schéma. Les pièces sans numéro de référence sur le schéma sont simplement destinées à compléter l'illustration.

**Part number** - Numéro de pièce détachée : si aucun numéro de pièce n'est spécifié, le composant n'est pas disponible en tant que pièce détachée. Une ligne qui apparaît en gras correspond à un ensemble. Une pièce dont le numéro est suivi d'un point noir est comprise dans l'ensemble apparaissant en gras juste au-dessus.

“<<< >>>” indique à consulter une autre liste.

Si le numéro de pièce d'une pièce spécifique est placé au-dessous de la ligne de référence/nom, il faut choisir le type/version de la machine.

**Qty** - Quantité : indique le nombre de pièces avec le numéro de référence correspondant. « AR » signifie « As required » (comme requis) : il s'agit de la quantité ou du nombre à déterminer.

**Name** - Désignation de la pièce : la traduction des désignations anglaises est disponible dans le document "Glossary of part names" (Glossaire des désignations des pièces).

**Remarks** - Remarques : informations supplémentaires concernant la pièce.

Une série de lettres peut indiquer qu'une pièce spécifique a été certifiée par l'organisme autorisé mentionné, conformément aux codes et règlements de la liste.

Les dimensions sont indiquées en millimètres.

## HU - HASZNÁLATI ÚTMUTATÓ

### 1 ALKATRÉSZRENDELÉS

Mindig adja meg a cikkszámot, a kért elemek nevét és mennyiségét, valamint a készülék típusát és gyári számát.

A Szerviz -  szimbólummal jelölt oldalak a szervizkészlet(ek) egyes alkatrészeire vonatkoznak. A készlet teljes tartalmát lásd az "1 - Service kits" (1 - Szervizkészletek) fejezetben.

### 2 A TÁBLÁZAT OSZLOPAI

**Ref.** - Hivatkozási szám: a felsorolt alkatrészt a megfelelő ábrához társítja. A rajzon csak hivatkozási számmal ellátott alkatrészek láthatók. Az ábra hivatkozási szám nélküli részei csak az összeszerelés módját illusztrálják.

**Part number** - ha nincs megadva cikkszám, az adott alkatrészt nem kapható pótalkatrészként. A vastag vonal szerelvényt jelez. Ha a cikkszám után fekete pont áll, az alkatrész a jobbra fent vastaggal jelölt szerelvény része.

A „<<< >>>” jel átirányít egy másik listához, amely a „Name” elemmel azonos nevű.

Ha egy adott alkatrész cikkszámát a „Ref.”/„Name” oszlopba helyezik, ki kell választani a készülék típusát/verzióját.

**Qty** - Mennyiség: az adott hivatkozási számhoz kapcsolódó alkatrészek számát jelöli. Az „AR” jelentése „As required” (igény szerint): itt megadhatja a mennyiséget vagy a számot.

**Name** - Az alkatrész neve: az angol nyelvű elnevezések fordításai az „Alkatrészek listája” c. dokumentumban található.

**Remarks** - Az alkatrésszel kapcsolatos többletinformáció.

Egy betűsor jelzi azt, hogy az adott alkatrészt az illetékes hatóság a lista kódjainak vagy szabályainak megfelelő tanúsítvánnyal látta el.

A mérési eredmények milliméterben értendők.

## IT - ISTRUZIONI PER L'USO

### 1 ORDINE DI PARTI DI RICAMBIO

Indicare sempre il numero categorico, il nome e la quantità delle parti richieste, come pure il tipo e il numero di serie della macchina.

Le pagine contrassegnate dal simbolo di assistenza -  - descrivono componenti appartenenti ai kit di manutenzione. Per informazioni sul contenuto completo del kit, consultare il capitolo "1 - Service kits" (1 - Kit di manutenzione).

### 2 INFORMAZIONI SULLE COLONNE

**Ref.** - Numero di riferimento: indica un componente specifico elencato nel disegno. Nel disegno sono presenti solo i componenti con un numero di riferimento. I componenti senza numero di riferimento sono presenti al solo scopo di illustrare il gruppo.

**Part number** - Numero categorico: se non è specificato nessun numero categorico, il componente non è disponibile come parte di ricambio. Una riga in grassetto indica un assemblaggio. Una parte il cui numero è seguito da un punto nero è compresa nell'assemblaggio stampato in grassetto in alto a destra.

"<<<< >>>>" indica di consultare un altro elenco di parti di ricambio.

Quando il numero di catalogo di una parte specifica è messo sotto la linea del riferimento/denominazione si deve fare una scelta in base al tipo/versione della macchina.

**Qty** - Quantità: indica il numero di componenti relativo al numero di riferimento. „AR“ significa „As required“ (Come richiesto): devono essere determinati la quantità o il numero.

**Name** - Nome parte: le traduzioni dei nomi inglesi dei componenti possono essere reperite nel "Glossary of part names" (Glossario dei nomi parti).

**Remarks** - Ulteriori informazioni sul componente.

Una serie di lettere possono indicare la certificazione di un componente da parte di un ente autorizzato specificato, in conformità alle normative riportate nell'elenco.

Le misure sono espresse in millimetri.

## LT - NAUDOJIMO INSTRUKCIJA

### 1 DETALIŲ UŽSAKYMAS

Visada nurodykite detalės numerį, pavadinimą ir reikiamą kiekį bei įrenginio tipą ir serijos numerį.

Puslapiuose, pažymėtuose techninio aptarnavimo simboliu -  -, yra aptarnavimo reikmenų rinkinio (-ių) dalių. Norėdami gauti informacijos apie visą rinkinio turinį, žr. skyrių "1 - Service kits" (1 - Aptarnavimo reikmenų rinkiniai).

### 2 INFORMACIJA STULPELYJE

**Ref.** - Nuorodos numeris: susieja sąrašą nurodytą detalę ir brėžinį. Brėžinyje pavaizduotos tik detalės, turinčios nuorodos numerį. Brėžinio detalės, neturinčios nuorodos numerio, tik iliustruoja komplektinį bloką.

**Part number** - detalės numeris: jeigu detalės numeris nenurodytas, komponento kaip atsarginės detalės įsigyti negalima. Eilutėje, kuri parodyta paryškintu šriftu, yra agregatas.

Detalė, po kurios numerio eina juodas taškas, yra įmontuota paryškintu šriftu aukščiau išspausdintame agregate.

„<<<< >>>>“ nukreipia į kita sąrašą, kurio pavadinimas toks pat, kaip „Name“ (detalės pavadinimas).

Kai specifinės detalės numeris yra nurodytas žemiau „Ref.“ (nuoroda) / „Name“ (detalės pavadinimas) eilutės, reikia apsispręsti dėl įrenginio tipo/versijos.

**Qty** - Kiekis: naudojamas su atitinkamu nuorodos numeriu ir nurodo detalių kiekį. „AR“ reiškia „As required“ (prireikus): dar nežinomas kiekis ar skaičius.

**Name** - detalės pavadinimas: anglišku pavadinimų vertimus galima rasti dokumente "Įrangos dalių terminai".

**Remarks** - Papildoma informacija apie detalę.

Raidžių derinys gali rodyti, kad konkrečiai detalei sertifikuotą išdavė įgaliota institucija pagal sąrašo nurodymus ir taisykles.

Matmenys pateikti milimetrais.

## LV - INSTRUKCIJAS LIETOŠANAI

### 1. PASŪTĪŠANAS DETALAS

Vienmēr norādiet nepieciešamās iekārtas detaļas numuru, nosaukumu un daudzumu, kā arī tipu un mašīnas seriālo numuru.

Lappuses, kas apzīmētas ar apkopes simbolu -  - satur Apkopes komplekta(u) daļas. Pilnam komplekta saturā pārskatam, skatiet nodaļu "1 - Service kits" (1 - Apkopes komplekti).

### 2. KOLONNAS INFORMĀCIJA

**Ats.** - Inventāra numurs: savieno atbilstošās saraksta daļas ar attēlu. Tikai detaļas ar inventāra numuru ir parādītas attēlā. Detaļas attēlā bez inventāra numura ir montāžai, vienkārši paskaidrotas attēlā.

**Part number** - detaļas numurs: ja nav norādīts detaļas numurs, komponents nav pieejams kā rezerves detaļa. Treknrakstā parādītā līnija ir montāža. Detaļa, aiz kuras numura seko melns punkts, ir ietverta tieši augšpusē treknrakstā drukātajā montāžā.

"<<<< >>>>" novirza uz citu sarakstu, kuram ir tāds pats nosaukums kā "Nosaukums".

Kad kādas noteiktas detaļas numurs ir novietots zem līnijas "Ats."/"Nosaukums" ir jāizvēlas iekārtas veids/versija.

**Qty** - daudzums: norāda detaļas daudzumu savienojumā ar attiecīgo inventāra numuru. "AR" nozīmē "As required" (pēc vajadzības): daudzums vai numurs, kuru jānosaka.

**Name** - detaļas nosaukums: angļu nosaukumu tulkojumus var atrast dokumentā "Detaļu nosaukumu vārdnīca".

**Remarks** - speciāla informācija par detaļu.

Burtu rindīņa, saskaņā ar saraksta noteikumiem un kodiem, var norādīt, ka šo detaļu ir sertificējusi autorizēta organizācija.

Izmēri ir norādīti milimetros.

## NL - INSTRUCTIES VOOR HET GEBRUIK

### 1 BESTELLEN VAN ONDERDELEN

Vermeld altijd het onderdeelnummer, de benaming en de hoeveelheid van de gewenste onderdelen, alsmede het type en het serienummer van de machine.

Pagina's gemarkeerd met het servicesymbool -  - bevatten onderdelen uit servicekits. Voor de complete inhoud van de kit, zie paragraaf "1 - Service kits" (1 - Servicekits).

### 2 KOLOM INFORMATIE

**Ref.** - Referentienummer: koppelt een specifiek onderdeel in de lijst aan de desbetreffende tekening. Alleen onderdelen met een referentienummer zijn in de tekening afgebeeld.

Onderdelen zonder referentienummer die op de tekening voorkomen, worden slechts getoond om het samenstel te illustreren.

**Part number** - Onderdeelnummer: indien geen onderdeelnummer is aangegeven, is de betreffende component niet als reserveonderdeel verkrijgbaar. Een regel in een vet lettertype is een samenstel. Een onderdeel waarvan het nummer gevolgd wordt door een zwart rondje, maakt deel uit van het vet afgedrukte samenstel direct erboven.

"<<<< >>>>" verwijst naar een andere lijst met dezelfde titel als de "Name" (benaming).

Als het onderdeelnummer van het desbetreffende onderdeel onder de regel "Ref."/"Name" (Ref./Benaming) staat vermeld, moet er een keuze met betrekking tot het machinetype en de machineversie worden gemaakt.

**Qty** - Aantal: geeft het aantal onderdelen aan in samenhang met het overeenkomstige referentienummer. "AR" betekent "As required" (benodigde hoeveelheid): de hoeveelheid of het aantal moet nader worden bepaald.

**Name** - Naam van het onderdeel: vertalingen van de Engelse benamingen zijn te vinden in het document "Glossary of part names" (Woordenlijst van onderdelen).

**Remarks** - Extra informatie over het onderdeel.

Een reeks letters kan aangeven dat een bepaald onderdeel gecertificeerd is door het opgegeven bevoegde orgaan, in overeenstemming met de codes of voorschriften in de lijst.

Afmetingen zijn in millimeters vermeld.

## NO - BRUKSANVISNING

### 1 BESTILLING AV DELER

Angi alltid delenummeret, navnet og antallet deler samt type- og serienummeret for maskinen.

Sidene som er merket med Service-symbolet - , omtaler deler av servicesettene. Du finner informasjon om hele innholdet i settet i kapittel "1 - Service kits" (1 - Servicesett).

### 2 FORKLARING TIL KOLONNENE

**Ref.** – Referansenummer: knytter en bestemt del i listen til tegningen. Deler uten referansenummer vises ikke på tegningen. Delene på tegningen som ikke har referansenummer, er tatt med for å illustrere monteringen.

**Part number** – Delenummer: Hvis det ikke er angitt noe delenummer, kan ikke delen bestilles med reservedel. En fet linje er en montering. En del som har et nummer som er etterfulgt av en svart prikk, er omfattet i monteringen med fet skrift ovenfor.

“<<< >>>” henviser til en annen liste som heter det samme som “Navn”.

Når delenummeret til en bestemt del plasseres under linjen “Ref.”/”Name” må man velge hva slags type/versjon maskinen er.

**Qty** – Antall: angir hvor mange deler som er knyttet til referansenummeret. “AR” står for “As required” (“etter behov”): Antall eller nummer må spesifiseres.

**Name** – Delenavn: Oversettelsen av de engelske navnene finner du i dokumentet Ordlister med delenavn.

**Remarks** – Anmerkninger: tilleggsinformasjon om delen.

Bokstaver kan indikere at en bestemt del er sertifisert i henhold til det autoriserte organet som er angitt, i samsvar med kodene eller reglene for listen.

Mål er angitt i millimeter.

## PL - INSTRUKCJA UŻYTKOWANIA

### 1 ZAMAWIANIE CZĘŚCI

Zawsze podawać numer części, nazwę i ilość potrzebnych elementów, a także typ i numer seryjny urządzenia.

Strony oznaczone symbolem -  - zawierają części zestawów serwisowych. Pełną zawartość zestawów można znaleźć w rozdziale “1 - Service kits” (1 - Zestawy serwisowe).

### 2 OBJAŚNIENIA KOLUMN

**Ref.** - Numer referencyjny: łączy konkretną część z listy ze schematem. Na schemacie prezentowane są wyłącznie części posiadające numer referencyjny. Części na schemacie nie mające numeru referencyjnego umieszczone w celu zilustrowania montażu.

**Part number** - Numer części: jeśli nie podano numeru części, dany element nie jest dostępny jako część zapasowa. Tekst wytłuszczony oznacza zespół. Część, po numerze której występuje czarna kropka, wchodzi w skład wytłuszczonego zespołu wskazanego powyżej po prawej stronie.

„<<< >>>” służą do przechodzenia do innej listy o tym samym tytule, co w kolumnie „Name” (Nazwa).

Jeśli numer dla konkretnej części jest umieszczony poniżej wiersza „Ref.”/”Name”, należy wybrać typ/wersję maszyny.

**Qty** - Ilość: oznacza liczbę części w odniesieniu do odpowiadającego im numeru referencyjnego. „AR” oznacza „As required” (Wg zapotrzebowania): ilość zostanie uzgodniona.

**Name** - Nazwa części: tłumaczenie nazw angielskich można znaleźć w dokumencie „Glossary of part names” (Słownik części).

**Remarks** - Informacje dodatkowe o danej części.

Ciąg liter może informować, że dana część uzyskała certyfikat określonej, upoważnionej organizacji, zgodnie z kodami lub zasadami z listy.

Wymiary zostały podane w milimetrach.

## PT - INSTRUÇÕES PARA UTILIZAÇÃO

### 1 ENCOMENDA DE PEÇAS

Especificar sempre a referência da peça, o nome e a quantidade de itens necessários, bem como o tipo e o número de série da máquina.

Páginas marcadas com o símbolo de assistência -  - contêm peças de kits de assistência. Para ver todos os conteúdos do kit consultar o capítulo “1 - Service kits” (1 - Kits de assistência).

### 2 INFORMAÇÃO SOBRE AS COLUNAS

**Ref.** - Número de referência: estabelece a ligação entre uma peça específica listada e o desenho. No desenho, apenas são mostradas peças com um número de referência. As peças mostradas no desenho que não apresentem um número de referência servem apenas para ilustrar o conjunto.

**Part number** - Referência da peça: se não for indicada a referência da peça, o componente não está disponível como peça sobresselente. Uma linha em negrito representa um conjunto. Uma peça cujo número esteja seguido de um ponto preto está incluída no conjunto impresso em negrito, imediatamente acima.

“<<< >>>” conduz a outra lista com o mesmo título de “Name”.

Quando a referência da peça específica se encontra por baixo da linha “Ref.”/”Name”, é preciso escolher o tipo/versão da máquina.

**Qty** - Quantidade: indica o número de peças relacionadas com o número de referência correspondente. “AR” significa “As required” (consoante requerido): quantidade ou número a determinar.

**Name** - Nome da peça: é possível encontrar traduções dos nomes ingleses das peças no documento “Glossário de designações de peças”.

**Remarks** - Informação extra sobre a peça.

Uma série de letras pode indicar que uma determinada peça foi certificada pela entidade autorizada referida, de acordo com os códigos ou as normas da lista.

As medidas são indicadas em milímetros.

## RO - INSTRUCȚIUNI DE UTILIZARE

### 1 COMANDAREA PIESELOR

Specificați întotdeauna numărul de reper, numele și cantitatea articolelor necesare și tipul și numărul de serie ale mașinii.

Paginile marcate cu simbolul Service -  - conțin componente din kituri de service. Pentru conținutul complet al acestui kit consultați capitolul “1 - Service kits” (1 - Kituri de service).

### 2 INFORMAȚIILE DIN COLOANE

**Ref.** - Numărul de referință: corelează piesa respectivă din listă cu desenul. În desen sunt prezentate numai piesele care au numere de referință. Piesele din desen care nu au niciun număr de referință se află acolo numai pentru a ilustra ansamblul.

**Part number** - Număr de reper: dacă nu este specificat niciun număr de reper, componenta nu este disponibilă ca piesă de schimb. O linie îngroșată reprezintă un ansamblu. Un reper al cărui număr este urmat de un punct negru este cuprins în ansamblul tipărit îngroșat de deasupra sa.

“<<< >>>” direcționează către o altă listă care are titlul identic cu “Nume”.

Când numărul de reper al piesei respective este plasat sub linia “Referință”/”Nume”, este obligatorie selectarea unui tip sau a unei versiuni a mașinii.

**Qty** - cantitate: indică numărul de piese corespunzătoare numărului de referință respectiv. “AR” înseamnă “Conform necesar”: cantitate sau număr care urmează a fi determinat.

**Name** - Nume reper: traduceriile numelor englezești pot fi găsite în documentul “Glosar de nume de repere”.

**Remarks** - Informații suplimentare despre piese.

O serie de litere poate indica faptul că o anumită piesă a fost certificată de organismul de autorizare specificat, în conformitate cu regulile sau codurile listei.

Dimensiunile sunt date în milimetri.

## RU - Правила пользования

### 1 ЗАКАЗ ДЕТАЛЕЙ

Всегда указывайте номер по каталогу, наименование и количество требуемых позиций, а также тип и серийный номер машины. Страницы, помеченные символом Service - , содержат информацию о сервисном(ых) наборе(ах). Полное содержание сервисного набора приведено в главе "1 - Service kits" (1 - Сервисные наборы).

### 2 ИНФОРМАЦИЯ О СТОЛБЦЕ

**Ref.** - Справочный номер: связывает деталь, указанную в списке, с чертежом. На чертеже показаны только детали, имеющие справочные номера. Детали на чертеже без справочных номеров показаны только для иллюстрации сборки.

**Partnumber** - Каталогный номер: если каталожный номер не указан, то данный компонент нельзя заказать как запчасть. Жирным шрифтом показаны сборочные единицы. Деталь, после номера которой следует черная точка, входит в состав сборочной единицы, набранной жирным шрифтом непосредственно над ней. Кавычки "<<<< >>>>" ссылаются на другой список того же наименования, что и "Name" (Наименование детали).

Если каталожный номер находится под линией "Ref."/"Name", это означает, что необходимо сделать выбор в соответствии с типом/исполнением машины.

**Qty** - Количество: указывает количество деталей в соответствии с их справочным номером. "AR" означает "As required" (По требованию): количество или номер необходимо определить.

**Name** - Наименование детали: перевод английских наименований находится в "Glossary of Part Names" (Словаре наименований деталей).

**Remarks** - Примечания - дополнительная информация о детали. Ряд букв может означать, что конкретная деталь сертифицирована указанным уполномоченным лицом, в соответствии с кодами или правилами в перечне. Размеры даны в миллиметрах.

## SK - NÁVOD NA POUŽITIE

### 1 OBJEDNÁVANIE SÚČASTÍ

Vždy zadajte číslo súčasti, názov a množstvo požadovaných položiek a takisto typ a výrobné číslo zariadenia.

Strany označené servisným symbolom - , obsahujú časti servisnej súpravy/servisných súprav. Úplný zoznam príslušnej súpravy nájdete v kapitole "1 - Service kits" (1 - Servisné súpravy).

### 2 INFORMÁCIE V STĽPCOCH

**Ref.** - Referenčné číslo: slúži na prepojenie konkrétnej uvedenej súčasti k príslušnému výkresu. Na výkrese sú zobrazené len súčasti s referenčným číslom. Súčasti bez referenčného čísla na výkrese slúžia len na ilustráciu montážnej skupiny.

**Part number** - Číslo súčasti: ak nie je určené žiadne číslo súčasti, daný komponent nie je k dispozícii ako náhradná súčiastka. Riadok uvedený tučným písmom predstavuje montážnu skupinu. Súčasť, za ktorej číslom nasleduje čierna bodka, je zahrnutá vo vyššie uvedenej hrubo vytlačenej zostave vpravo.

„<<<< >>>>“ smeruje na ďalší zoznam s rovnakým názvom ako v položke „Name“.

Keď sa číslo určitej súčasti nachádza pod riadkom „Ref.“/„Name“, je potrebné vybrať typ/verziu zariadenia.

**Qty** - Množstvo: označuje počet súčasti vzhľadom na príslušné referenčné číslo. Skratka „AR“ znamená „As required“ (podľa potreby): množstvo alebo číslo bude stanovené.

**Name** - Názov súčiastky: preklady anglických názvov môžete nájsť v dokumente „Register názvov súčastí“.

**Remarks** - Ďalšie informácie o danej súčasti.

Postupnosť písmen môže určovať, že určitá súčasť bola certifikovaná stanovenou oprávnenou inštitúciou podľa kódov alebo pravidiel v danom zozname.

Rozmery sú uvedené v milimetroch.

## SL - NAVODILA ZA UPORABO

### 1 NAROČANJE DELOV

Vedno navedite številko dela, ime in količino zahtevanih predmetov ter tip in serijsko številko stroja.

Strani, označene s simbolom za servis , vsebujejo dele servisnih kompletov. Za celotno vsebino kompleta si oglejte poglavje "1 - Service kits"(1 - Servisni kompleti).

### 2 INFORMACIJE O STOLPCU

**Ref.** - Referenčna številka: povezuje določeni navedeni del z risbo. Na risbi so prikazani samo deli z referenčno številko. Deli na risbi, ki nimajo referenčne številke, so namenjeni samo prikazu sklopa.

**Part number** - Številka dela: če številka dela ni navedena, komponenta ni na voljo kot rezervni del. Vrstica z odebeljenim tiskom predstavlja sklop. Del, katerega številki sledi črna pika, spada v sklop, natisnjen z odebeljenim tiskom neposredno nad njim.

“<<<< >>>>” vas usmeri na drug seznam z enakim nazivom kot “Name (Ime)”.

Če je pod vrstico “Ref.”/“Name” navedena številka dela za določeni del, mora izbrati temeljiti na tipu/različici stroja.

**Qty** - Količina: določa število delov v povezavi z ustrezno referenčno številko. “AR” pomeni “As required” (kot je zahtevano): količina ali število za določitev.

**Name** - Ime dela: prevodi angleških imen se nahajajo v dokumentu “Pojmovnik z imeni delov”.

**Remarks** - Dodatne informacije o delu.

Zaporedje črk lahko pomeni, da je bil določen del certificiran s strani navedenega pooblaščenega organa, v skladu z zakoni ali pravili seznama.

Mere so podane v milimetrih.

## SV - INSTRUKTIONER FÖR ANVÄNDNING

### 1 BESTÄLLA DELAR

Ange alltid reservdelsnummer, namn och antal delar som önskas, samt typbeteckning och tillverkningsnummer på maskinen.

Sidor markerade med servicesymbolen -  - innehåller delar av servicesatser. Hela innehållet i satsen redovisas i kapitlet "1 - Service kits" (1 - Servicesatser).

### 2 SPALTINFORMATION

**Ref.** - Referensnummer: kopplar ihop en viss reservdel i förteckningen med ritningen. Endast reservdelar med referensnummer visas i ritningen. Reservdelar som saknar referensnummer i ritningen finns med för att illustrera själva monteringen.

**Part number** - Reservdelsnummer: om reservdelsnummer saknas finns komponenten inte som reservdel. Monteringsanvisningar visas med fet stil. En reservdel vars nummer följs av en svart punkt finns med i den fetstilta monteringsanvisningen direkt ovanför.

“<<<< >>>>” hänvisar till en annan lista med samma titel som “namnet”.

När reservdelsnumret för den specifika delen är placerad nedanför “Ref.”/“Namn”-raden måste ett val göras utifrån maskinens typ/version.

**Qty** - Antal: anger hur många delar som är kopplade till motsvarande referensnummer. “AR” betyder “As required” (som erfordras): antal eller nummer bestäms senare.

**Name** - Reservdelsbeteckningar: översättning av de engelska beteckningarna återfinns i dokumentet “Glossary of part names” (Ordlista med reservdelsbeteckningar).

**Remarks** - Extraintformation om reservdelen.

En uppsättning bokstäver kan ange att en viss reservdel har certifierats av det befullmäktigade organet, enligt koderna eller reglerna i förteckningen.

Mått anges i millimeter.

## TR - KULLANIM TALİMATLARI

### 1 PARÇA SİPARİŞİ

Gerekli öğelerin parça numaraları, ad ve miktarının yanı sıra makinenin tip ve seri numarasını da mutlaka belirtin.

Servis simgesi -  taşıyan sayfalarda Servis kiti (kitleri) parçaları bulunmaktadır. Kitle ilgili tüm bilgilere ulaşmak için "1 - Service kits" (1 - Servis kitleri) bölümüne başvurun.

### 2 KOLON BİLGİLERİ

**Ref.** - Referans numarası: özel olarak listelenmiş bir parça için çizimden bağlantı sağlar. Sadece referans numarası olan parçalar çizimde gösterilir. Çizimde referans numarası bulunmayan parçalar sadece montaj işlemlerini göstermek için verilmiştir.

**Part number** - Parça numarası: parça numarası belirtilmemişse, bileşen yedek parça olarak bulunmamaktadır. Koyu harflerle gösterilen satır montajdır. Numarasından sonra siyah bir nokta gelen parça, yukarıda koyu harflerle basılmış montaja dahildir.

"<<< >>>", "Name" (Ad) ile aynı başlıkta bir başka listeye yönlendirir.

Belirli bir parçanın parça numarası "Ref."/"Name" (Ref./Ad) satırının altına yerleştirildiğinde, makine tipi/modeli konusunda seçim yapılmalıdır.

**Qty** - Miktar: uygun referans numarasıyla bağlantılı olarak parça sayısını gösterir. "AR", "As required" (Gerektiği gibi) anlamına gelmektedir: belirlenecek olan miktar veya sayı.

**Name** - Parça adı: İngilizce adların çevirileri, "Parça adları sözlüğü"nde bulunabilir.

**Remarks** - Açıklamalar: Parça hakkında ek bilgiler.

Bir dizi harf, belirli bir parçanın yasalara veya liste kurallarına uygun olarak özel yetkili bir makam tarafından sertifikalandırıldığını gösterebilir.

Ölçümler milimetre cinsinden verilmiştir.

## ZH - 使用说明

### 1 订购零件

订购零件时必需指定零件号、零件名称、零件数量以及机器的类型和系列号。

在标有维修标记  的页面上有维修组件的部分内容。该组件的完整内容请参见章节“1 - 维修组件”“1 - Service kits”。

### 2 每列内容的说明

**Ref.** - 图示编号：将零件清单中列出的零件与示意图中的该零件相关联。零件清单中仅显示有图示编号的零件。示意图中没有标注图示编号的零件仅用来在图中帮助示意。

**Part number** - 零件号：如果某项没有零件号，则该项不可作为零备件供应。以粗体印刷的零件号表示这是一个装置。编号后面有一个黑点的零件包含在其上面以粗体印刷的装置中。

"<<< >>>" 表示该装置的零件清单在手册中以同一名称另外分章单列。

如果指定的零件号位于"Ref."(图示编号)"Name"(零件名称)列上，则订购零件时必须指明机器的类型/版本。

**Qty** - 数量：显示相应的图示编号的零件个数。"AR"表示"As required"：即根据需要确定数量。

**Name** - 零件名称：在文件“零件名称对照表”中可以找到对应的英文名称。

**Remarks** - 零件的附注。

一连串的字母表示某一特定零件依照标准或规定的要求已获得指定授权机构的认证。





## Table of contents

1	Service kits .....	5
2	Drive arrangement.....	11
3	Air system - Air inlet.....	15
4	Air system - Unloader assembly.....	17
5	Air system - Pack .....	19
6	Air system - Full Feature .....	21
7	Air system - Full Feature - Air dryer.....	23
8	Air system - Air receiver - Pack .....	29
9	Air system - Air receiver - Full Feature .....	31
10	Oil system .....	33
11	Oil system - Oil vessel connections .....	35
12	Cubicle - IEC .....	39
13	Cubicle - UL-cUL .....	45
14	Bodywork - Pack .....	51
15	Bodywork -Full Feature .....	53
16	Bodywork - Pack - Baffles .....	55
17	Bodywork - Full Feature - Baffles .....	57
18	Standard option - Air dryer - Bypass.....	59
19	Standard option - Air dryer - Bypass with DDx filter.....	61
20	Standard option - Air dryer - Bypass with DDx/PDx filters .....	63
21	Standard option - Air dryer - Electrical equipment .....	65
22	Standard option - Full Feature - DDx filter .....	67
23	Standard option - Full Feature - DDx/PDx filters .....	69
24	Standard option - Electronic Water Drain - Pack.....	71
25	Standard option - Electronic Water Drain - No US Air receiver .....	73
26	Standard option - Electronic Water Drain - US Air receiver .....	75
27	Standard option - Heavy duty filter .....	77
28	Standard option - Main switch .....	79
29	Standard option - Timer drain - Pack.....	81



30	Standard option - Timer drain - No US Air receiver .....	83
31	Standard option - Timer drain - US Air receiver .....	85
32	Standard option - Freeze protection .....	87



## Service kits

1

Ref.	Part number	Qty	Name	Remarks
		<b>1</b>	<b>Oil</b>	
	2901 0245 01		ROTO-INJECTFLUID - 5 litre	
	2901 1700 00		ROTO-XTEND DUTY - 5 litre	
	2901 0522 00		ROTO-INJECTFLUID - 20 litre	
	2901 1701 00		ROTO-XTEND DUTY - 20 litre	
	<b>2902 0161 00</b>	<b>1</b>	<b>Unloader kit</b>	
	0160 0996 86 •	2	Screw	
	0211 1957 50 •	2	Screw	
	0301 2318 00 •	2	Washer	
	0661 1000 40 •	1	Seal washer	
	0663 2104 98 •	1	O-ring	
	0663 2111 55 •	1	O-ring	
	0663 7142 00 •	1	O-ring	
	1622 1755 80 •	1	Valve ass'y	
	1622 1790 00 •	1	Ttape	
	1622 1797 05 •	1	Bushing	
	1622 1798 00 •	1	Quad-ring	
	1622 2903 00 •	1	Spring guide	
	1622 2904 00 •	1	Spring	
	1622 2905 00 •	1	Sealing	
	1622 2906 00 •	1	Bushing	
	1622 3694 80 •	1	Assembly	
	9820 3654 00 •	1	Instruct drwg	
	<b>2901 1077 00</b>	<b>1</b>	<b>Scavenge line kit</b>	
	0661 1000 38 •	1	Seal washer	
	0663 2108 11 •	1	O-ring	
	1613 9005 01 •	1	Non return valve	
	<b>2901 0866 01</b>	<b>1</b>	<b>Filter kit</b>	
	1613 6105 01 •	1	Oil filter	
	1613 8720 00 •	1	Filter element	
	1622 0351 01 •	1	Oil separator	
	9820 4572 00 •	1	Instruction	
	<b>2901 5005 00</b>	<b>1</b>	<b>Shaft seal kit</b>	
	1622 0009 00 •	1	Bushing	
	0663 2103 22 •	1	O-ring	
	2904 0005 00 •	1	Instruction	
	<b>2901 1399 00</b>	<b>1</b>	<b>Minimum pressure valve kit</b>	
			7.5 bar(e), 8.6 bar(e), 10 bar(e), 100 psig, 125 psig, 150 psig	
	0661 1000 60 •	1	Seal	
	0663 2105 40 •	1	O-ring	
	1513 0063 00 •	1	Spring	
	1513 0064 00 •	1	Spring	
	1513 0401 01 •	1	Valve disc	
	2904 1015 00 •	1	Instruction mpv	
	9820 4845 00 •	1	Service diagram	
	<b>2901 1411 00</b>	<b>1</b>	<b>Minimum pressure valve kit</b>	
			13 bar(e), 175 psig	



## Service kits

1

Ref.	Part number	Qty	Name	Remarks
	0661 1000 60 •	1	Seal	
	0663 2105 40 •	1	O-ring	
	1513 0064 00 •	1	Spring	
	1513 0401 01 •	1	Valve disc	
	1622 0259 00 •	1	Spring	
	2904 1015 00 •	1	Instruction mpv	
	9820 4846 00 •	1	Service diagram	
	<b>2901 0068 00</b>	<b>1</b>	<b>Thermostatic kit 38°C</b>	
	0663 2101 95 •	1	O-ring	
	1622 7064 01 •	1	Thermostatic valve	
	2904 0036 02 •	1	Instruction	
	9820 4573 00 •	1	Thermostatic valve kit	
	<b>2901 0069 00</b>	<b>1</b>	<b>Thermostatic kit 65°C</b>	
	0663 2101 95 •	1	O-ring	
	1622 7064 02 •	1	Thermostatic valve	
	2904 0036 02 •	1	Instruction	
	9820 4573 00 •	1	Thermostatic valve kit	
	<b>2902 0350 00</b>	<b>1</b>	<b>Thermostatic valve 75°C</b>	
	0663 2113 76 •	1	O-ring	
	1622 7064 03 •	1	Thermostatic valve	
	9820 9644 00 •	1	Kit	
	<b>2901 0712 00</b>	<b>1</b>	<b>Overhaul kit</b>	
	0663 2111 28 •	1	O-ring	
	0663 2133 00 •	3	O-ring	
	0663 6137 00 •	1	O-ring	
	1613 9227 80 •	1	Drain	
	2904 0154 00 •	1	Instruction	
	<b>2202 7440 01</b>	<b>1</b>	<b>Electric drain dryer kit</b>	
	<b>2901 1212 00</b>	<b>1</b>	<b>Spare element kit PDX / PDXP 55</b>	
	<b>2901 1214 00</b>	<b>1</b>	<b>Spare element kit DDX / DDXP 55</b>	
	<b>2901 1639 00</b>	<b>1</b>	<b>Element mounting kit</b>	
	0661 1000 38 •	1	Seal washer	
	0663 2103 22 •	1	O-ring	
	0663 2111 35 •	3	O-ring	
	0663 3125 00 •	1	O-ring	
	0663 7134 00 •	3	O-ring	
	0663 7142 00 •	1	O-ring	
	9820 4571 00 •	1	Instruction	
	<b>2901 0716 00</b>	<b>1</b>	<b>Motor bearing kit</b>	
	0502 1091 78 •	1	Bearing	
	0502 1091 79 •	1	Bearing	
	2901 0338 02 •	8	Grease tube motor bearings	
	2901 0719 00 •	1	Motor sealing kit	



## Service kits

1

Ref.	Part number	Qty	Name	Remarks
	<b>2901 1189 00</b>	<b>1</b>	<b>Preventive maintenance kit</b>	
			7.5 bar(e), 8.6 bar(e), 10 bar(e), 100 psig, 125 psig, 150 psig	
	1089 9556 23 •	1	Filter	
	2901 0068 00 •	1	Thermostat	
	2901 0866 01 •	1	Filter kit	
	2901 1077 00 •	1	Scavenge line kit	
	2901 1399 00 •	1	Service kit min press valve	
	2902 0161 00 •	1	Unloader kit	
	<b>2901 1203 00</b>	<b>1</b>	<b>Preventive maintenance kit</b>	
			13 bar(e), 175 psig	
	1089 9556 23 •	1	Filter	
	2901 0069 00 •	1	Thermostat kit	
	2901 0866 01 •	1	Filter kit	
	2901 1077 00 •	1	Scavenge line kit	
	2901 1411 00 •	1	Service kit min press valve	
	2902 0161 00 •	1	Unloader kit	

2

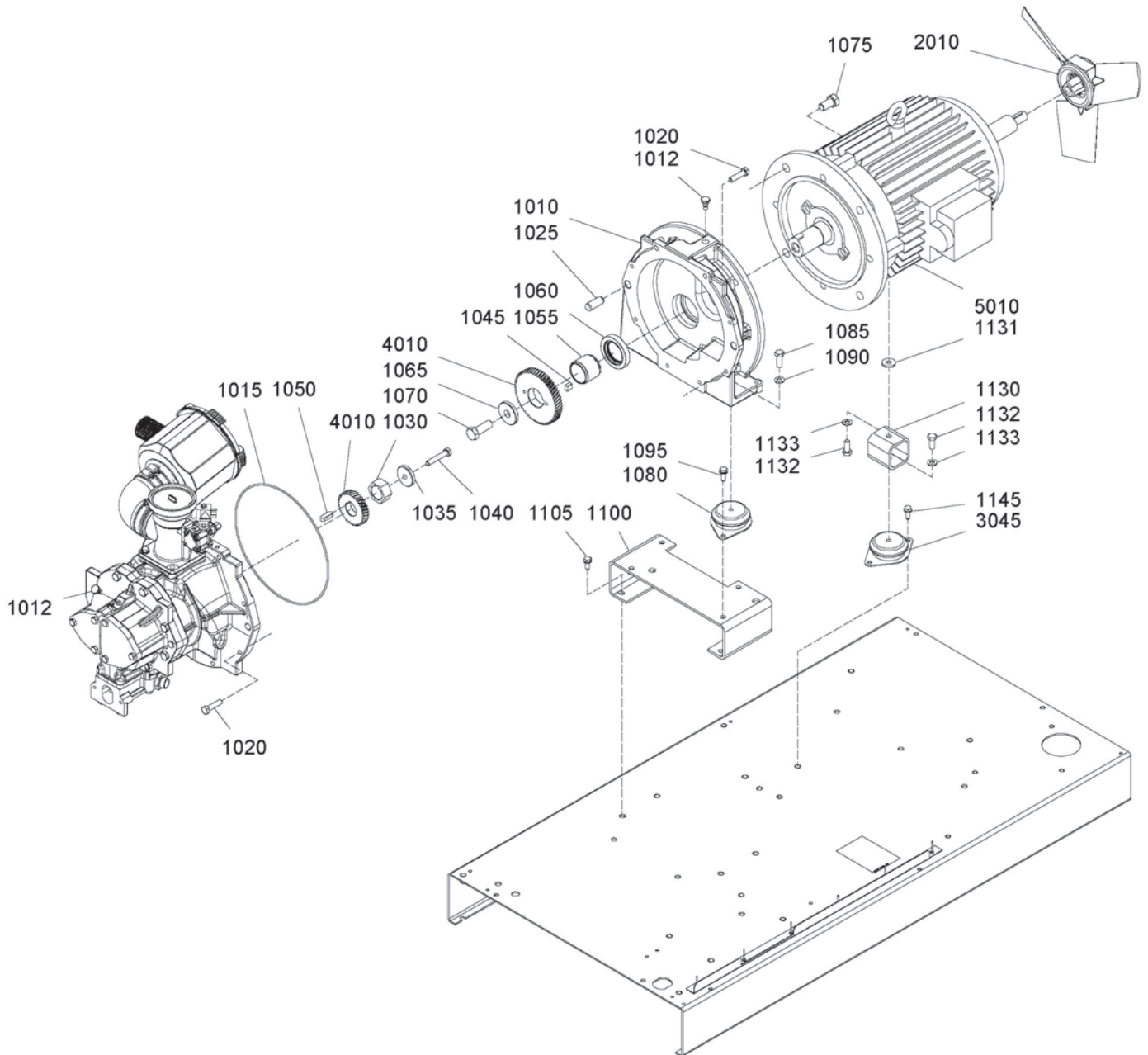



## Drive arrangement

2

Ref.	Part number	Qty	Name	Remarks
1010	1622 0007 00	1	Gear casing	
1012	1619 6032 00	2	Nipple (SPM)	
1015	0663 2103 22	1	O-ring	
1020	0147 1365 03	8	Hexagon bolt	
1025	0101 1951 40	2	Pin	
1030	1622 3400 00	1	Spacer	
1035	1622 3401 00	1	Washer	
1040	0211 1368 00	1	Cap screw	
1045	0337 0009 42	1	Key	
1050	0337 0009 45	1	Key	
1055	1622 0009 00	1	Bushing	
1060	1616 5742 00	1	Seal ring	
1065	1622 0010 00	1	Washer	
1070	0147 1478 03	1	Hexagon bolt	
1075	0147 1475 03	4	Hexagon bolt	
1080	1613 6752 01	2	Antivibr.pad	
1085	0147 1363 03	2	Hexagon bolt	
1090	0301 2344 00	2	Washer	
1095	0147 1962 72	4	Hexagon bolt	
1100	1622 0136 00	1	Support	
1105	0147 1963 08	4	Hexagon bolt	
1130	1622 4752 10	1	Spacer	
1131	0300 0274 93	1	Plain washer	
1132	0147 1362 03	2	Hexagon bolt	
1133	0301 2344 00	2	Washer	
1145	0147 1963 08	2	Hexagon bolt	
2010	1622 4783 00	1	Fan	
3045	1613 6752 01	1	Antivibr.pad	
4010		1	Gear set	
	1622 5991 88		GA 15 7.5 bar(e)	
	1622 5991 87		GA 15 8 bar(e)	
	1622 5991 81		GA 15 10 bar(e)	
	1622 5991 70		GA 15 13 bar(e)	
	1622 5991 86		GA 15 100 psig	
	1622 5991 92		GA 15 125 psig	
	1603 0702 79		GA 15 150 psig	
	1622 5991 74		GA 15 175 psig	
	1622 5991 94		GA 18 7.5 bar(e)	
	1622 5991 93		GA 18 8 bar(e)	
	1622 5991 71		GA 18 10 bar(e)	
	1622 5991 87		GA 18 13 bar(e)	
	1622 5991 88		GA 18 100 psig	
	1622 5991 87		GA 18 125 psig	
	1622 5991 81		GA 18 150 psig	
	1622 5991 92		GA 18 175 psig	
	1622 5991 68		GA 22 7.5 bar(e)	
	1622 5991 79		GA 22 8 bar(e)	
	1622 5991 94		GA 22 10 bar(e)	
	1622 5991 67		GA 22 13 bar(e)	
	1622 5991 93		GA 22 100 psig	
	1622 5991 67		GA 22 125 psig	
	1622 5991 88		GA 22 150 psig	
	1622 5991 87		GA 22 175 psig	
5010		1	Motor	

2

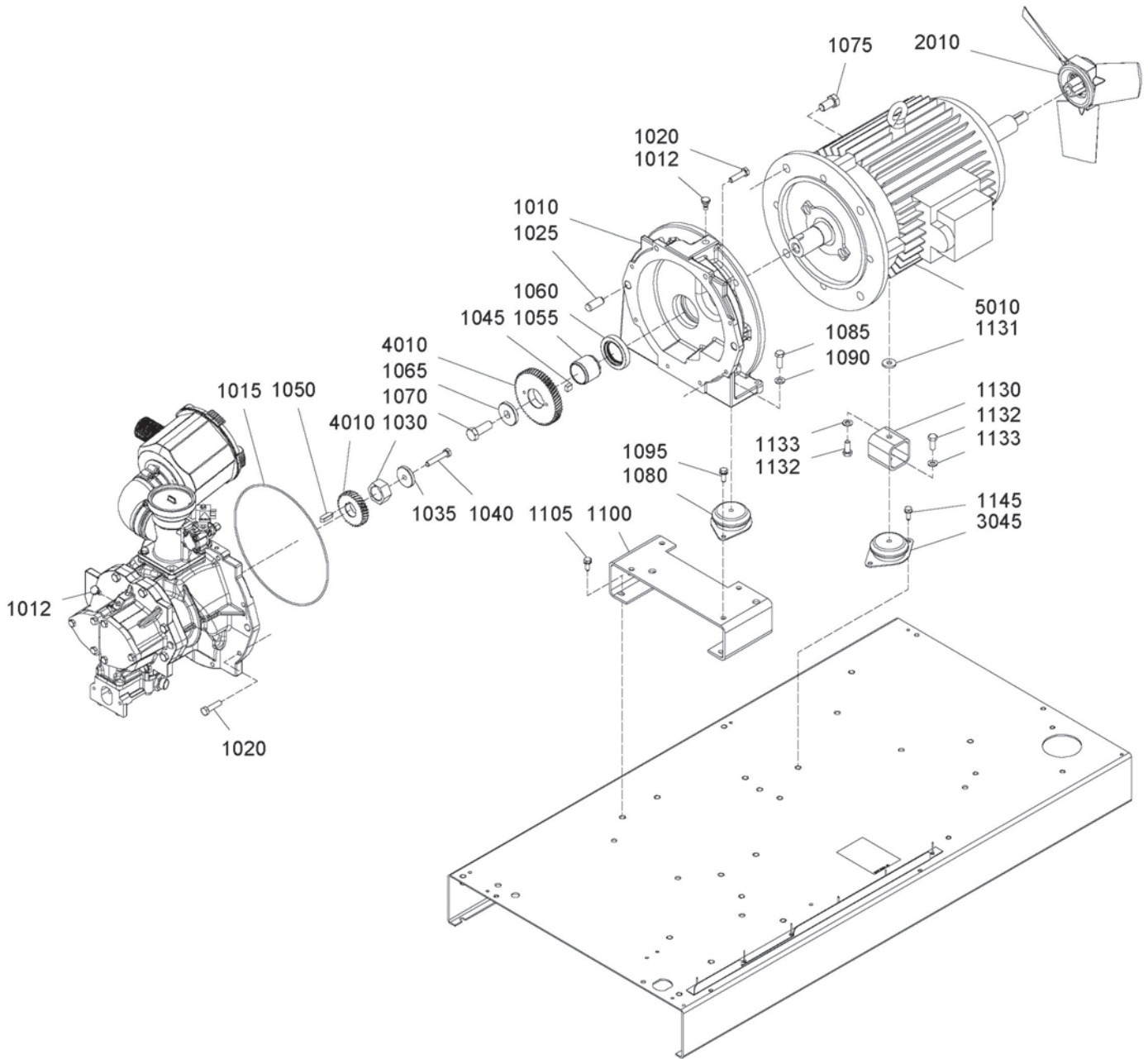

## Drive arrangement

2

Ref.	Part number	Qty	Name	Remarks
	1080 4251 32		GA 15 200-230-460V/60Hz	
	1080 4251 22		GA 15 230V/50Hz	
	1080 4251 33		GA 15 380V/60Hz	
	1080 4251 23		GA 15 400V/50Hz	
	1080 4251 37		GA 15 440-460V/60Hz	
	1080 4251 24		GA 15 500V/50Hz	
	1080 4251 34		GA 15 575V/60Hz	
	1080 4252 32		GA 18 200-230-460V/60Hz	
	1080 4252 22		GA 18 230V/50Hz	
	1080 4252 33		GA 18 380V/60Hz	
	1080 4252 23		GA 18 400V/50Hz	
	1080 4252 37		GA 18 440-460V/60Hz	
	1080 4252 24		GA 18 500V/50Hz	
	1080 4252 34		GA 18 575V/60Hz	
	1080 4253 32		GA 22 200-230-460V/60Hz	
	1080 4253 22		GA 22 230V/50Hz	
	1080 4253 33		GA 22 380V/60Hz	
	1080 4253 23		GA 22 400V/50Hz	
	1080 4253 37		GA 22 440-460V/60Hz	
	1080 4253 24		GA 22 500V/50Hz	
	1080 4253 34		GA 22 575V/60Hz	

3

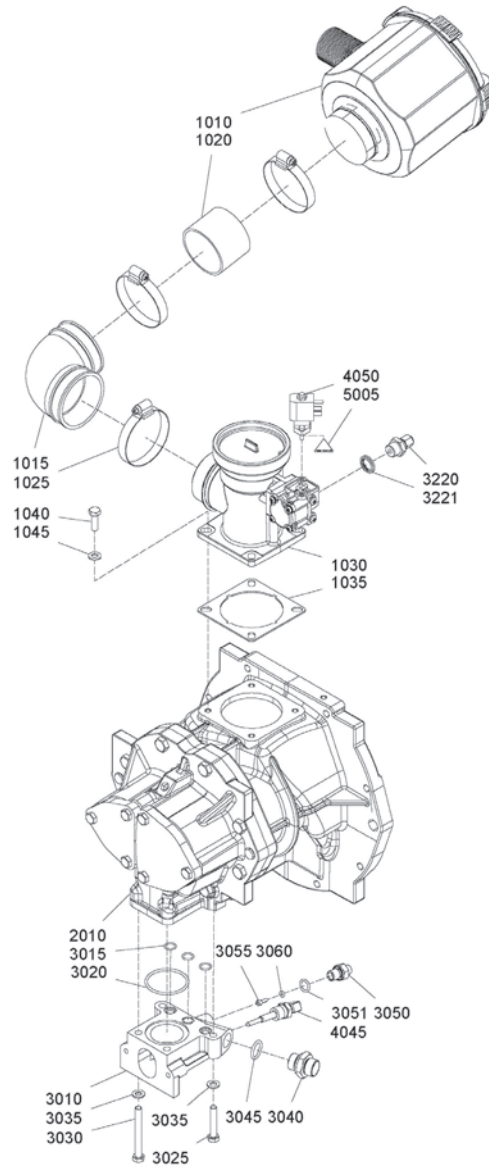

## Air system - Air inlet

3

Ref.	Part number	Qty	Name	Remarks
<b>1010</b>	<b>1613 8719 00</b>	<b>1</b>	<b>Filter housing</b>	
	1613 8720 00 •	1	Filter element	
1015	1622 4741 00	1	Elbow	
1020	1622 4780 00	1	Tube	
1025	0347 6114 00	3	Hose clip	
<b>1030</b>	<b>&lt;&lt;&lt;&gt;&gt;&gt;</b>	<b>1</b>	<b>Unloader assembly</b>	
1035	1622 7811 00	1	Gasket	
1040	0147 1325 03	4	Bolt	
1045	0301 2335 00	4	Washer	
2010	1616 6712 80	1	Service stage	
3010	1622 0014 01	1	Housing	
3015	0663 2111 35	3	O-ring	
3020	0663 7134 00	1	O-ring	
3025	0147 1329 03	2	Bolt	
3030	0147 1335 03	2	Bolt	
3035	0301 2335 00	4	Washer	
3040	0571 0035 96	1	Nipple	
3045	0663 3125 00	1	O-ring	
3050	1622 3468 20	1	Nozzle	
3051	0663 3119 00	1	O-ring	
3055	1613 9005 01	1	Valve	
3060	0663 2108 11	1	O-ring	
3220	0581 0001 02	1	Nipple	
3221	0661 1000 40	1	Seal washer	
4045	1089 0574 55	1	Temp.sensor	
4050		1	Solenoid Valve	
	1089 0702 09		110V/50Hz	
	1089 0702 10		120V/60Hz	
5005	1088 1001 01	1	Warning Mark	



4

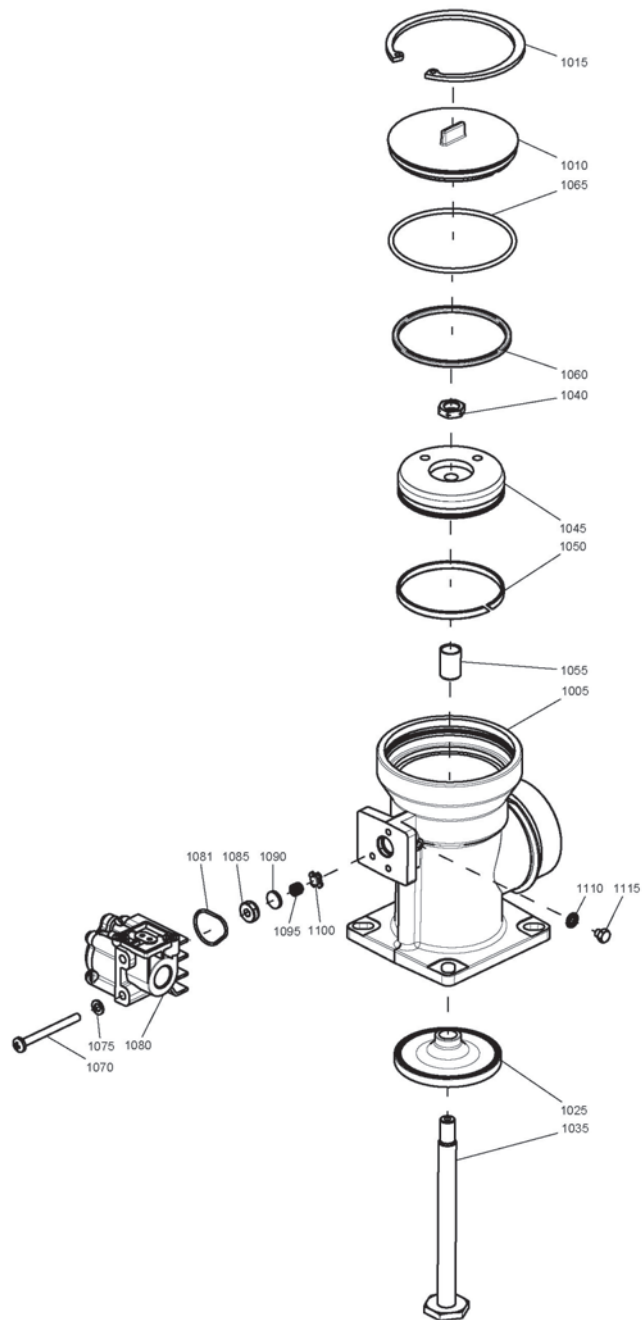

**Air system - Unloader assembly****4**

Ref.	Part number	Qty	Name	Remarks
	<b>1622 3162 82</b>	<b>1</b>	<b>Unloader assy</b>	
1010	1622 3162 00 •	1	Housing	
1015	1622 3164 00 •	1	Rod	
1020	1622 3163 00 •	1	Cover	
1025	1613 6818 01 •	1	Valve	
1030	1622 3168 00 •	1	Ring	
1035	1622 3169 00 •	1	Piston	
1040	1622 3173 00 •	1	Tape	
1045	0663 7149 00 •	1	O-ring	
1050	0663 2111 55 •	1	O-ring	
1055	0261 1090 99 •	1	Nut	
1060	0335 2179 00 •	1	Circlip	
1065	1622 3170 05 •	1	Bushing	
1070	0160 0996 86 •	2	Screw	
1075	0301 2318 00 •	2	Washer	
1080	1622 3694 80 •	1	Assembly	
1085	1622 3182 00 •	1	Guide	
1090	1622 3183 00 •	1	Seal	
1095	1622 3184 00 •	1	Bushing	
1100	1622 3185 00 •	1	Spring	

5

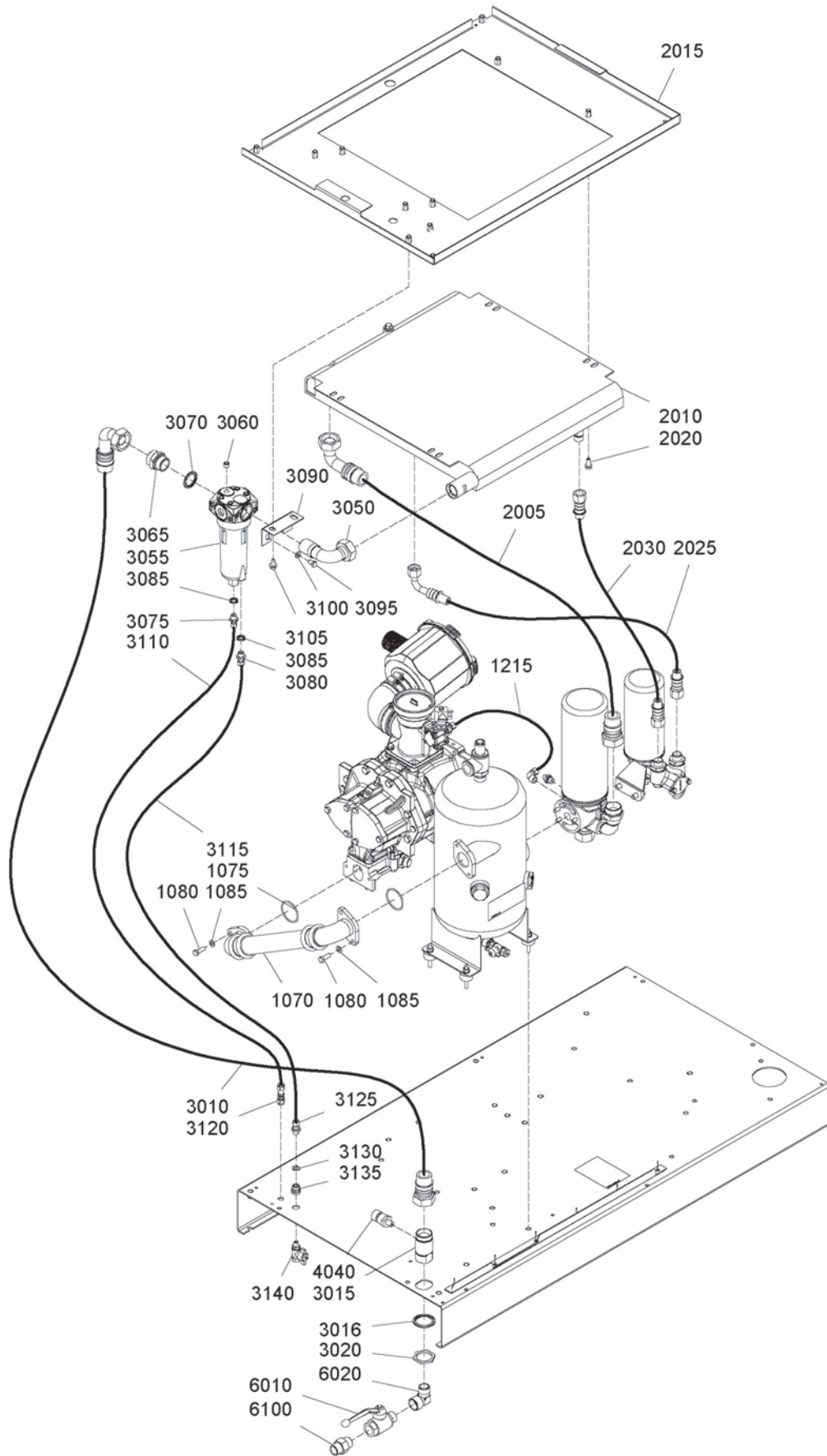



## Air system - Pack

5

Ref.	Part number	Qty	Name	Remarks
1070	1622 0015 00	1	Hose assembly	
1075	0663 7134 00	2	O-ring	
1080	0147 1325 03	4	Hexagon bolt	
1085	0301 2335 00	4	Washer	
1215	0070 6002 05	AR	Tube	
2005	0574 9911 35	1	Hose assembly	
2010		1	Cooler	
	1622 3928 00		GA 15	
	1622 3929 00		GA 18	
	1622 3930 00		GA 22	
2015		1	Plate	
	1622 4765 81		GA 15	
	1622 4764 81		GA 18	
	1622 8572 00		GA 22	
2020	0147 1963 08	7	Bolt	
2025	0575 1216 65	1	Hose assembly	
2030		1	Hose assly	
	0575 1205 12		GA 15	
	0575 1205 13		GA 18	
	0575 1205 13		GA 22	
3010	0574 9911 41	1	Hose assembly	
3015	1622 4739 50	1	Outlet	
3016	0661 1000 62	1	Seal washer	
3020	0697 9809 06	1	Lock nut	
3050	1622 4798 00	1	Pipe	
3055	1613 8222 80	1	WSD 25	
3060	0686 6128 00	1	Plug	
3065	2250 4983 00	1	Nipple	
3070	0661 1000 60	1	Seal washer	
3075	0581 0000 34	1	Coupling	
3080	0581 0000 35	1	Coupling	
3085	0661 1000 38	2	Seal washer	
3090	1622 4799 00	1	Support	
3095	0147 1321 03	2	Bolt	
3100	0301 2335 00	2	Washer	
3105	0226 0301 00	2	Screw	
3110	0070 6002 05	AR	Plastic tube	
3115	0070 6002 04	AR	Plastic tube	
3120	0581 0000 55	1	Pipe coupling	
3125	0581 0000 33	1	Coupling	
3130	0653 1046 00	1	Flat gasket	
3135	0581 0000 43	1	Coupling	
3140	0852 0010 55	1	Ball valve	
4040	1089 0575 54	1	Press.transducer	
6010		1	Ball valve	
	0852 0010 34		Floor mounted	
6020		1	Elbow	
	0605 9500 09		Floor mounted	
6100		1	Nipple	
	0603 4150 17		Floor mounted ASME	



6

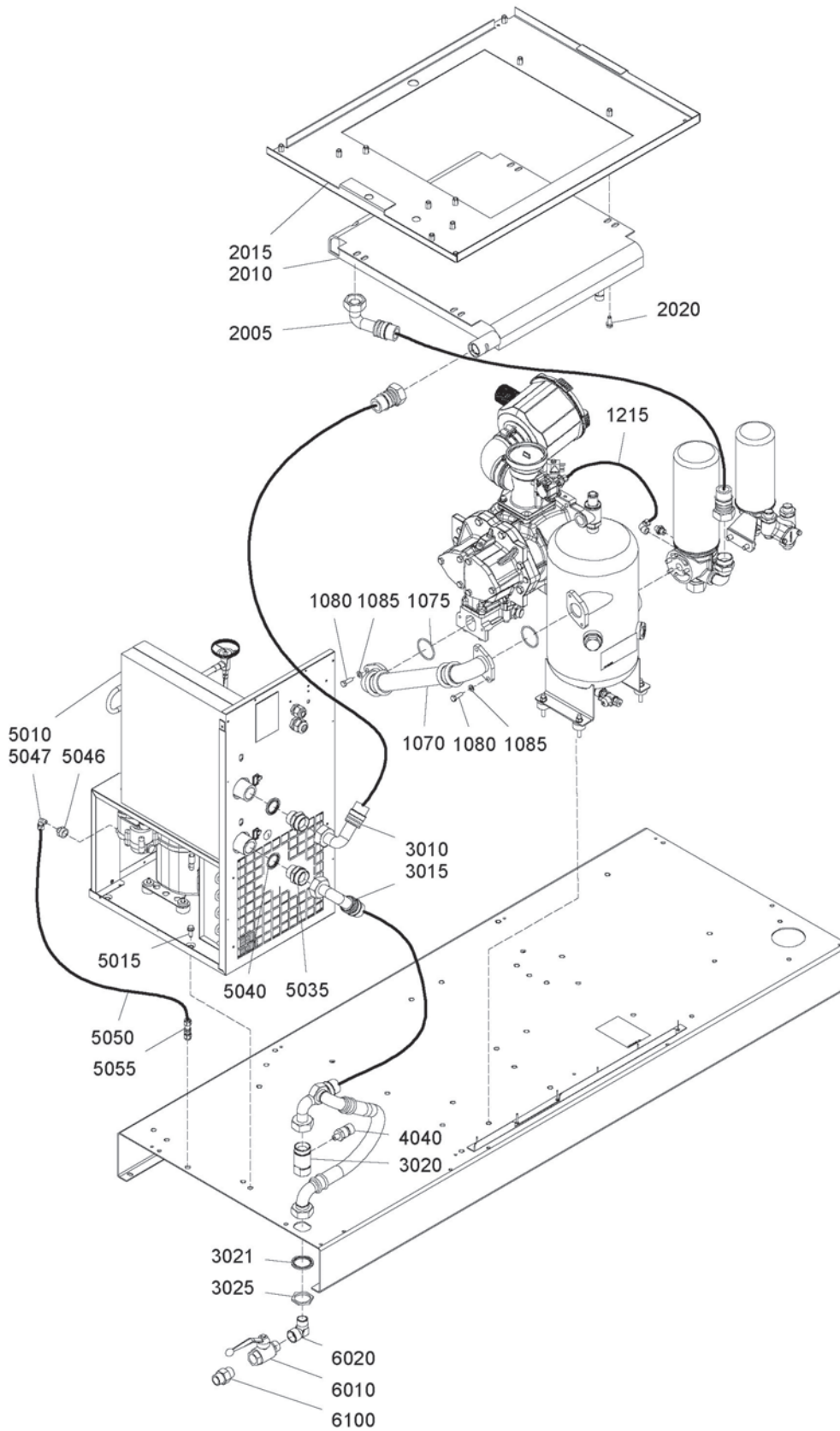

## Air system - Full Feature

6

Ref.	Part number	Qty	Name	Remarks
1070	1622 0015 00	1	Hose assembly	
1075	0663 7134 00	2	O-ring	
1080	0147 1325 03	4	Bolt	
1085	0301 2335 00	4	Washer	
1215	0070 6002 05	AR	Tube	
2005	0574 9911 35	1	Hose assembly	
2010		1	Cooler	
	1622 3928 00		GA 15	
	1622 3929 00		GA 18	
	1622 3930 00		GA 22	
2015		1	Plate	
	1622 4765 81		GA 15	
	1622 4764 81		GA 18	
	1622 8572 00		GA 22	
2020	0147 1963 08	7	Bolt	
3010	0575 0125 45	1	Hose assembly	
3015	0575 0785 01	1	Hose assembly	
3020	1622 4739 50	1	Outlet	
3021	0661 1000 62	1	Seal	
3025	0697 9809 06	1	Lock nut	
4040	1089 0575 54	1	Press. transducer	
<b>5010</b>	<b>&lt;&lt;&lt; &gt;&gt;&gt;</b>	<b>1</b>	<b>Air dryer</b>	
5015	0147 1963 08	3	Hexagon bolt	
5035			Nipple	
	2250 4983 00	2	A6X	
	0571 0035 90	2	A7X	
5040			Seal	
	0661 1000 44	2	A6X	
	0661 1000 61	2	A7X	
5046	0607 1151 06	1	Reducing socket	
5047	0581 1200 26	1	Elbow coupling	
5050	0070 6002 05	AR	Plastic tube	
5055	0581 0000 55	1	Coupling	
6010		1	Ball valve	
	0852 0010 34		Floor mounted	
6020		1	Elbow	
	0605 9500 09		Floor ounted	
6100		1	Nipple	
	0603 4150 17		Floor mounted ASME	



7

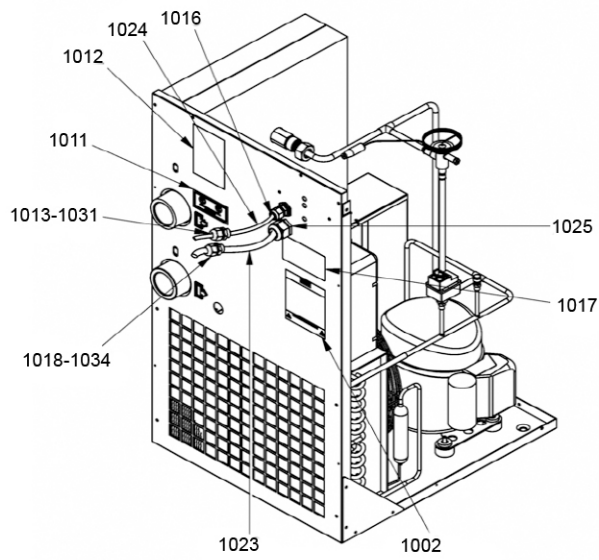
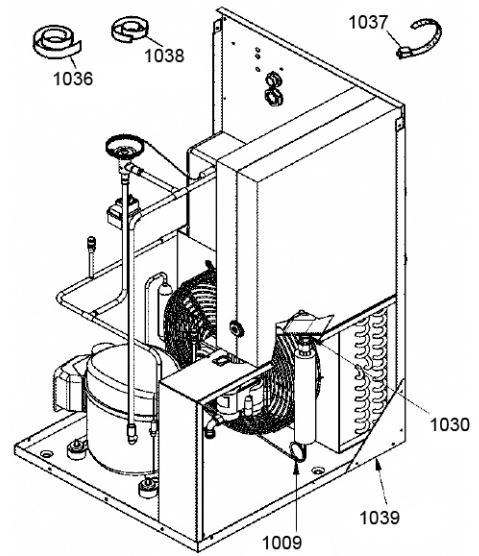
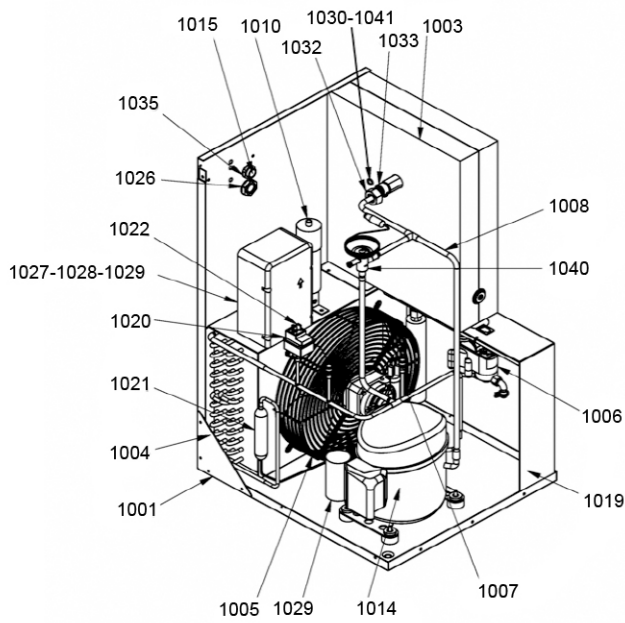

## Air system - Full Feature - Air dryer

7

Ref.	Part number	Qty	Name	Remarks
		<b>1</b>	<b>Air dryer</b>	
	<b>8092 2652 74</b>		GA 15 7.5 bar(e) A6X 50Hz	
	<b>8092 2652 74</b>		GA 15 8.6 bar(e) A6X 50Hz	
	<b>8092 2652 74</b>		GA 15 10 bar(e) A6X 50Hz	
	<b>8092 2652 74</b>		GA 15 13 bar(e) A6X 50Hz	
	<b>8092 2652 90</b>		GA 15 100 psig A6X 60Hz	
	<b>8092 2652 90</b>		GA 15 125 psig A6X 60Hz	
	<b>8092 2652 90</b>		GA 15 150 psig A6X 60Hz	
	<b>8092 2652 90</b>		GA 15 175 psig A6X 60Hz	
	<b>8092 2652 82</b>		GA 18 7.5 bar(e) A7X 50Hz	
	<b>8092 2652 82</b>		GA 18 8.6 bar(e) A7X 50Hz	
	<b>8092 2652 82</b>		GA 18 10 bar(e) A7X 50Hz	
	<b>8092 2652 74</b>		GA 18 13 bar(e) A6X 50Hz	
	<b>8092 2653 08</b>		GA 18 100 psig A7X 60Hz	
	<b>8092 2653 08</b>		GA 18 125 psig A7X 60Hz	
	<b>8092 2653 08</b>		GA 18 150 psig A7X 60Hz	
	<b>8092 2652 90</b>		GA 18 175 psig A6X 60Hz	
	<b>8092 2652 82</b>		GA 22 7.5 bar(e) A7X 50Hz	
	<b>8092 2652 82</b>		GA 22 8.6 bar(e) A7X 50Hz	
	<b>8092 2652 82</b>		GA 22 10 bar(e) A7X 50Hz	
	<b>8092 2652 82</b>		GA 22 13 bar(e) A7X 50Hz	
	<b>8092 2653 08</b>		GA 22 100 psig A7X 60Hz	
	<b>8092 2653 08</b>		GA 22 125 psig A7X 60Hz	
	<b>8092 2653 08</b>		GA 22 150 psig A7X 60Hz	
	<b>8092 2653 08</b>		GA 22 175 psig A7X 60Hz	
1001	• 2202 7360 81	1	Frame	
			A6X	
	2202 7383 81		A7X	
1002	• 2202 7801 00	1	Label	
			A6X 60Hz	
	2202 7802 00		A7X 60Hz	
1003	• 2202 7366 82	1	Heat exchanger	
			A6X	
	2202 7367 82		A7X	
1004	• 2202 7351 02	1	Condenser unit	
			A6X	
	2202 7352 01		A7X	
1005	• 2202 7373 01	1	Motor fan	
			A6X 50Hz	
	2202 7373 03		A6X 60Hz	
	2202 7373 02		A7X 50Hz	
	2202 7373 05		A7X 60Hz	
1006	• 2202 7440 01	1	Electric drain	
1007	• 2200 5997 43	1	Check valve	
1008	• 2202 7342 80	1	Pipe	
			A6X	
	2202 7334 80		A7X	
1009	• 2202 7413 02	1	Capillary	
			A6X	
	2202 7413 03		A7X	
1010	• 2202 7653 02	1	Run capacitor	
			A6X 50Hz	
	2202 7653 03		A7X 50Hz	
1011	• 2202 2611 92	1	Label UL	



7

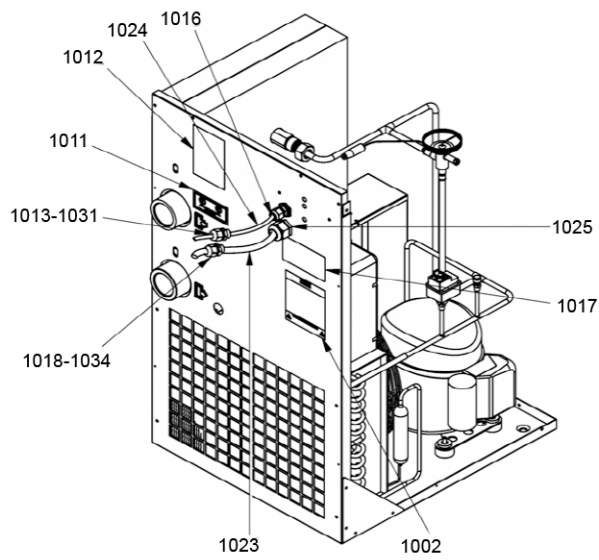
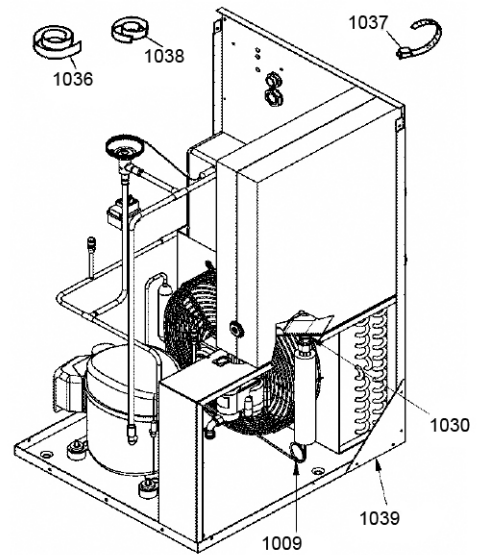
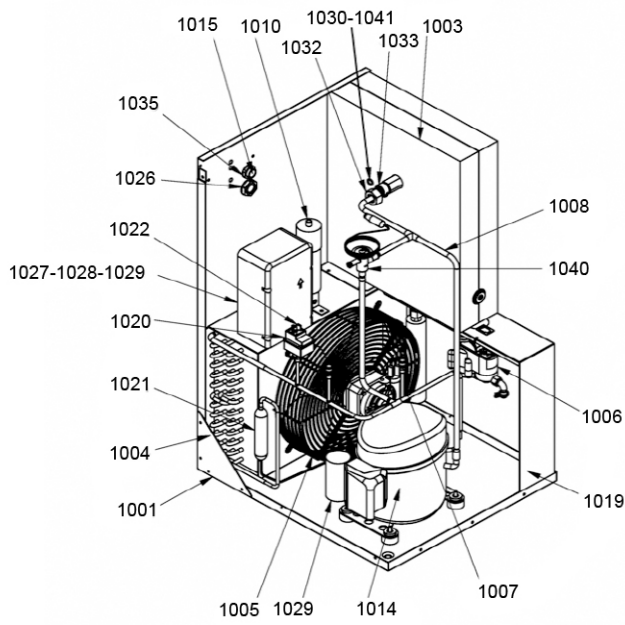

## Air system - Full Feature - Air dryer

7

Ref.	Part number	Qty	Name	Remarks
1012	1079 9901 09 •	1	Label	
1013	0698 5140 70 •	1	Cable gland	
1014	•	1	Refr. compressor	
	2202 7370 02		A6X 50Hz	
	2202 7370 06		A6X 60Hz	
	2202 7370 03		A7X 50Hz	
	2202 7370 08		A7X 60Hz	
1015	0697 9745 71 •	1	Reducer	
1016	0698 5141 24 •	1	Cable gland	
1017	•	1	Data plate	
1018	0698 5140 71 •	1	Cable gland	
1019	•	1	Stirrup	
	2202 7365 00		A6X	
	2202 7333 00		A7X	
1020	2200 6006 79 •		Pressure switch	
1021	2202 7569 01 •		Filter dryer	
1022	2200 7099 06 •		Terminal cap	
1023	•		Cubicle diagram	
	9828 4200 16		A6X 50Hz	
	9828 4400 31		A6X 60Hz	
	9828 4200 17		A7X 50Hz	
	9828 4400 32		A7X 60Hz	
1024	1089 0574 80 •	1	Thermoresistance	
1025	0698 5141 22 •	1	Cable gland	
1026	0697 9809 54 •	1	Nut	
1027	•	1	Start relay	
	2202 7651 05		A6X 50Hz	
	2202 7651 08		A6X 60Hz	
	2202 7651 06		A7X 50Hz	
	2202 7651 11		A7X 60Hz	
1028	•	1	Overload protector	
	2202 7652 05		A6X 50Hz	
	2202 7652 10		A6X 60Hz	
	2202 7652 06		A7X 50Hz	
	2202 7652 12		A7X 60Hz	
1029	•	1	Start capacitor	
	2202 7650 03		A6X 50Hz	
	2202 7650 09		A6X 60Hz	
	2202 7650 04		A7X 50Hz	
	2202 7650 10		A7X 60Hz	
1030	2202 7425 01 •		O-ring	
		2	A6X 50Hz	
		1	A7X 50Hz	
1031	0697 9809 30 •	1	Nut	
1032	•	1	Nut	
	2202 7466 02		A6X	
	2202 7466 04		A7X	
1033	•	1	Sleeve	
	2202 7466 01		A6X	
	2202 7466 04		A7X	
1034	0697 9809 20 •	1	Nut	
1035	0697 9809 53 •	1	Nut	
1036	0017 9862 67 •	AR	Tape	



7

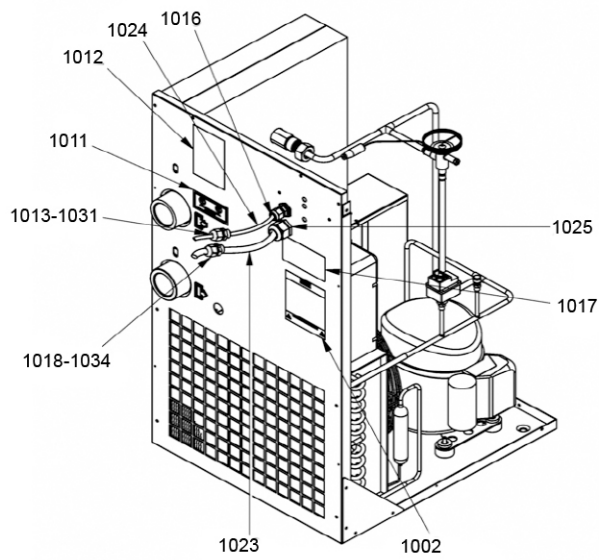
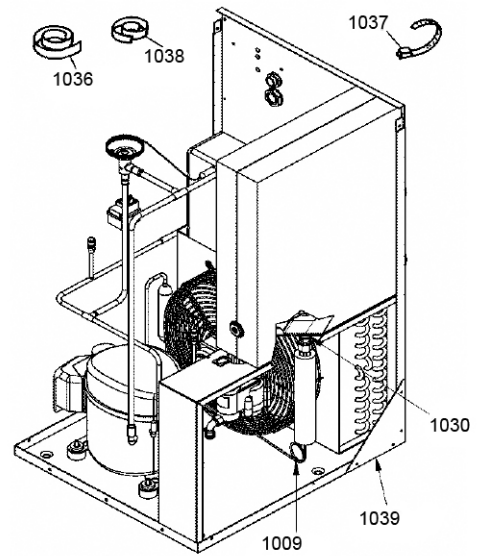
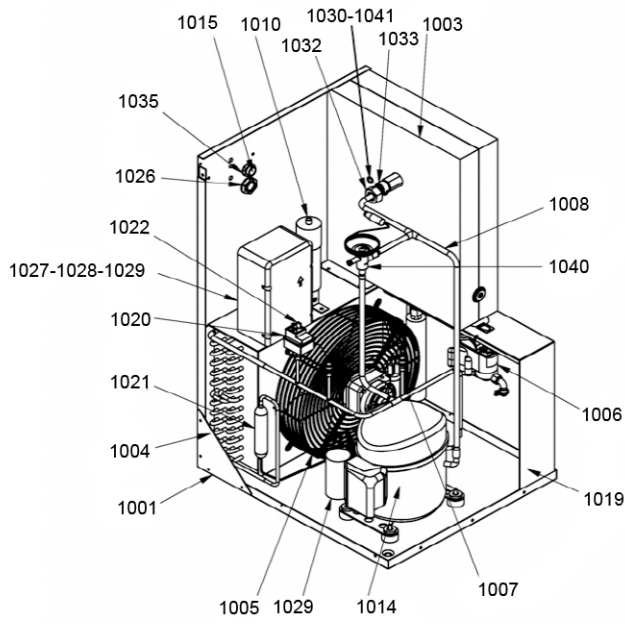



**Air system - Full Feature - Air dryer****7**

Ref.	Part number	Qty	Name	Remarks
1037	0348 0101 20 •	10	Cable tie	
1038	2202 7587 01 •	AR	Tape	
1039	2202 7706 00 •	2	Angle	
1040	2202 7324 02 •	1	Hot Gas Bypass valve	

8

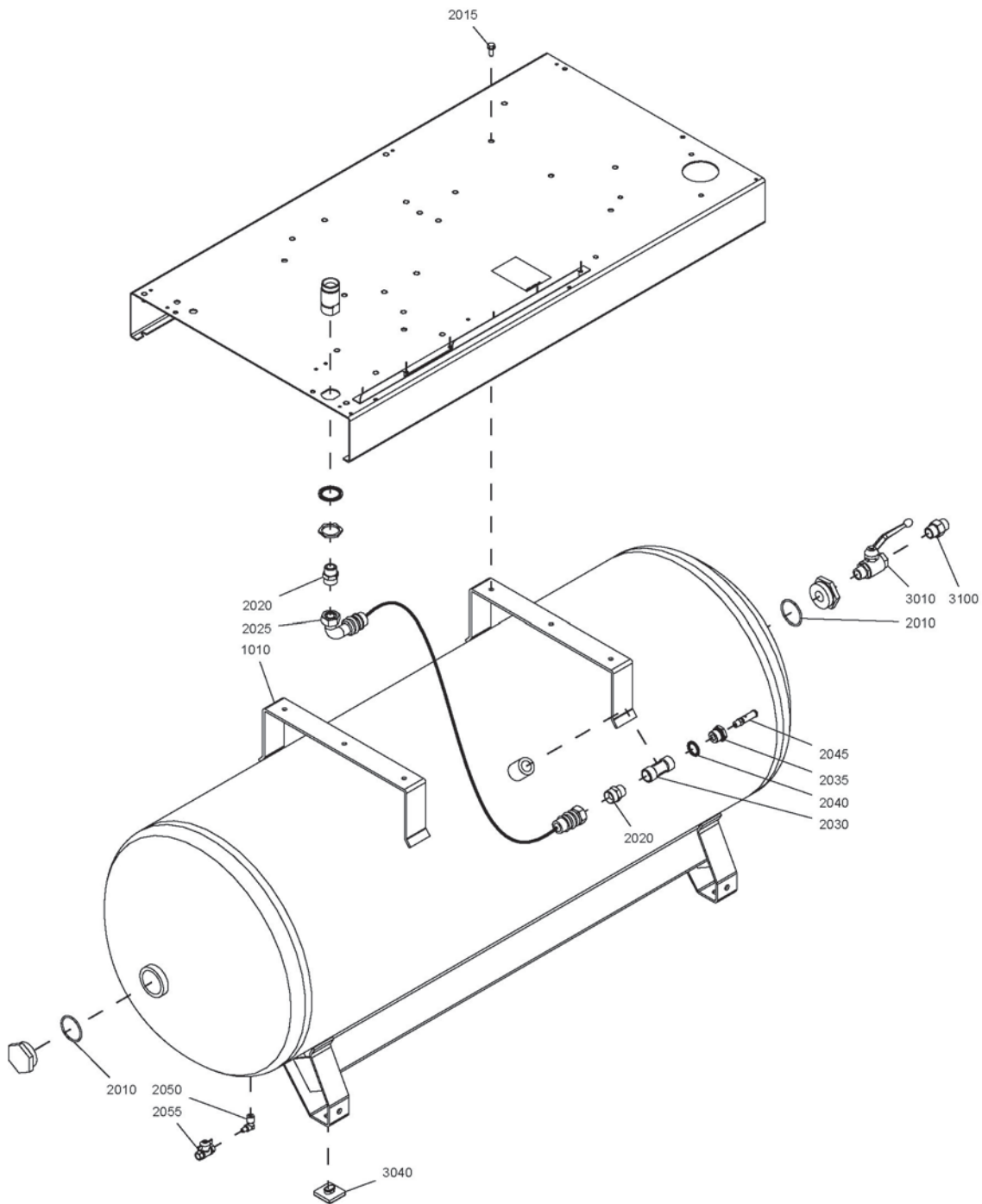

## Air system - Air receiver - Pack

8

Ref.	Part number	Qty	Name	Remarks
1010		1	Air receiver	
	1622 4785 00		ASME 200 psig 125 gallon	
	1622 4784 00		CE 14 bar(e) 500 litre	
	1622 4787 00		DIR 14 bar(e) 500 litre	
	1622 4786 00		MOM 200 psig 125 gallon	
	1622 4788 00		SQL 14 bar(e) 500 litre	
	1622 4785 50		US ASME 200 psig 125 gallon	
2010	0663 9202 00	2	O-ring	
2015	0147 1962 72	6	Bolt	
2020	0571 0035 53	2	Nipple	
2025	0575 0125 46	1	Hose assembly	
2030	0605 9500 10	1	Tee	
2035		1	Bushing	
	0605 8700 84		ASME	
	0605 8820 05		CE	
2040	0661 1000 43	1	Seal washer	
2045		1	Safety valve	
	0830 1008 85		ASME 200 psig	
	0830 1008 88		CE 13.5 bar(e)	
2050		1	Elbow	
	1503 2565 41		No US air receiver	
	0560 4400 51		US air receiver	
2055		1	Ball valve	
	0852 0010 36		No US air receiver	
	0085 2000 04		US air receiver	
3010	0852 0010 34	1	Ball valve	
3040	1502 4202 00	4	Pad	
3100		1	Nipple	
	0603 4150 17		ASME	



9

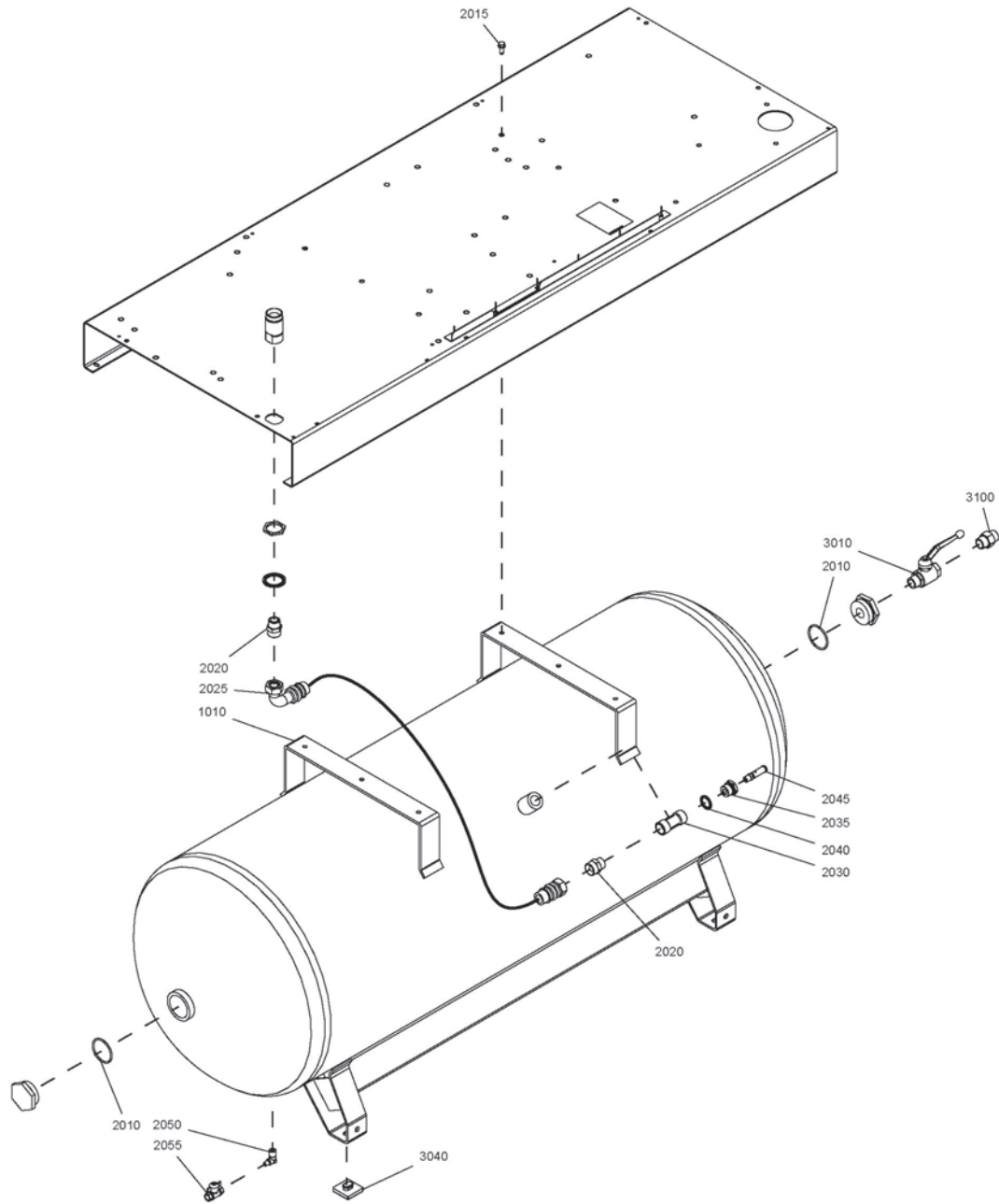

## Air system - Air receiver - Full Feature

9

Ref.	Part number	Qty	Name	Remarks
1010		1	Air receiver	
	1622 4785 00		ASME 200 psig 125 gallon	
	1622 4784 00		CE 14 bar(e) 500 litre	
	1622 4787 00		DIR 14 bar(e) 500 litre	
	1622 4786 00		MOM 200 psig 125 gallon	
	1622 4788 00		SQL 14 bar(e) 500 litre	
	1622 4785 50		US ASME 200 psig 125 gallon	
2010	0663 9202 00	2	O-ring	
2015	0147 1962 72	6	Bolt	
2020	0571 0035 53	2	Nipple	
2025	0575 0125 47	1	Hose assembly	
2030	0605 9500 10	1	Tee	
2035		1	Bushing	
	0605 8700 84		ASME	
	0605 8820 05		CE	
2040	0661 1000 43	1	Seal washer	
2045		1	Safety valve	
	0830 1008 85		ASME	
	0830 1008 88		CE	
2050		1	Elbow	
	1503 2565 41		No US air receiver	
	0560 4400 51		US air receiver	
2055		1	Ball valve	
	0852 0010 36		No US air receiver	
	0085 2000 04		US air receiver	
3010	0852 0010 34	1	Ball valve	
3040	1502 4202 00	4	Pad	
3100		1	Nipple	
	0603 4150 17		ASME	

10

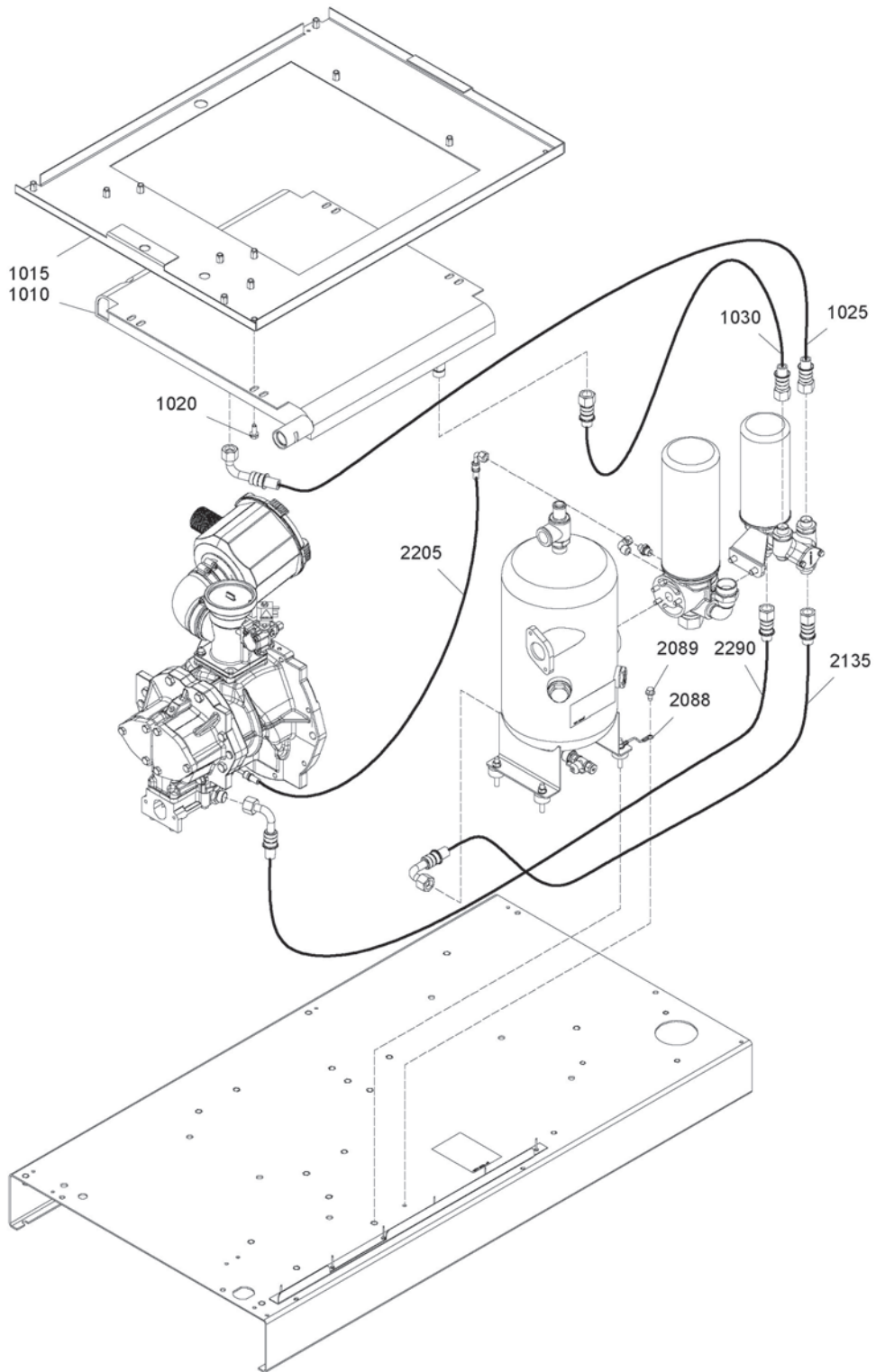

**Oil system****10**

Ref.	Part number	Qty	Name	Remarks
1010		1	Cooler	
	1622 3928 00		GA 15	
	1622 3929 00		GA 18	
	1622 3930 00		GA 22	
1015		1	Plate	
	1622 4765 81		GA 15	
	1622 4764 81		GA 18	
	1622 8572 00		GA 22	
1020	0147 1963 08	4	Bolt	
1025	0575 1216 65	1	Hose assembly	
1030		1	Hose assembly	
	0575 1205 12		GA 15	
	0575 1205 13		GA 18	
	0575 1205 13		GA 22	
2088	1613 8967 12	1	Grounding	
2089	0226 0301 00	1	Tapping screw	
2135	0575 1216 64	1	Hose assembly	
2205	0575 1244 52	1	Hose assembly	
2290	0575 1216 64	1	Hose assembly	

11

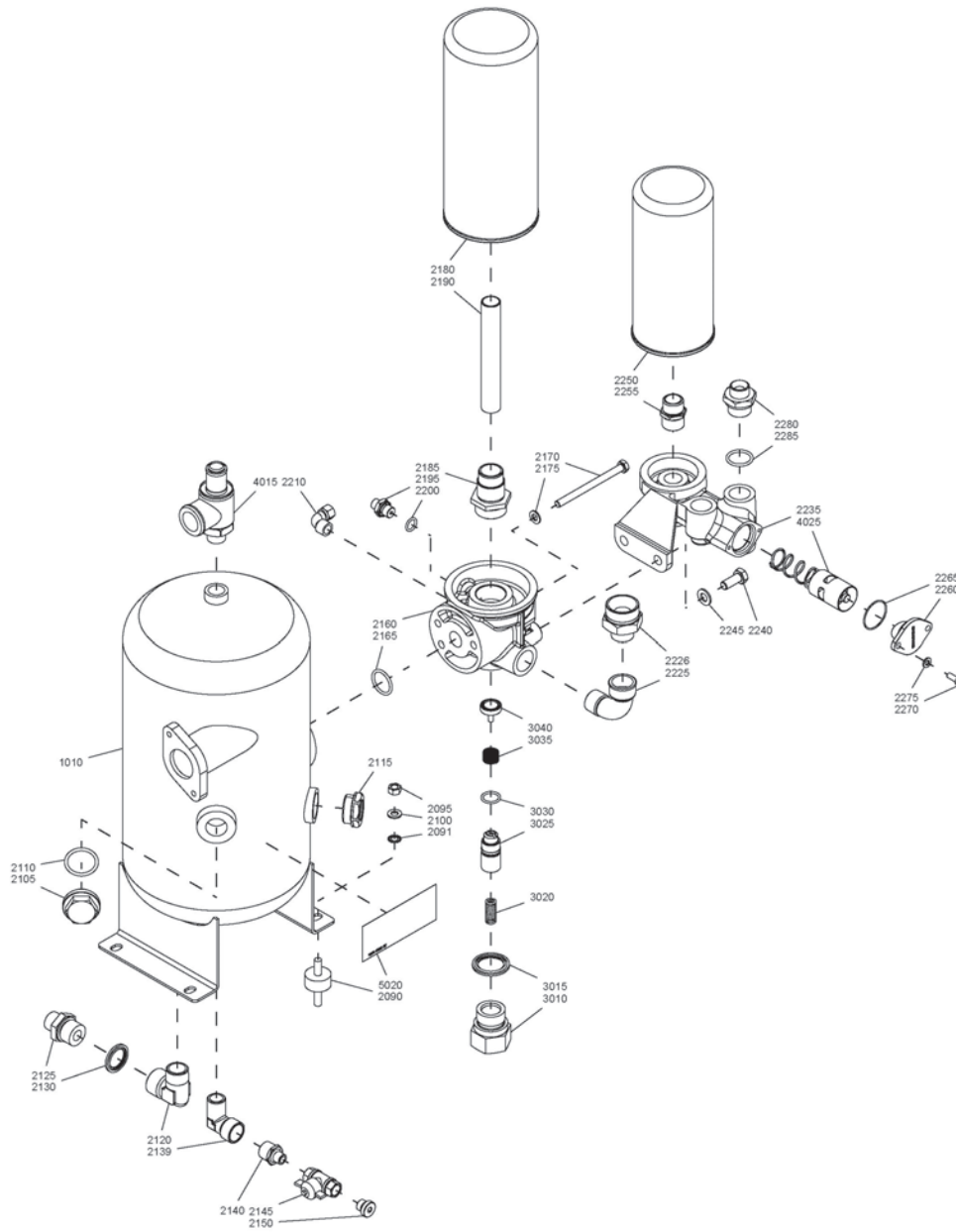



## Oil system - Oil vessel connections

11

Ref.	Part number	Qty	Name	Remarks
1010	1622 4702 50	1	Oil vessel	
2090	2235 2544 00	4	Damper	
2091	0333 3227 00	1	Lock washer	
2095	0266 2110 00	4	Nut	
2100	0301 2335 00	4	Washer	
2105	1202 8992 00	1	Plug	
2110	0663 2102 15	1	O-ring	
2115	1513 0167 00	1	Sight glass	
2120	0605 9500 09	1	Elbow	
2125	1079 5840 27	1	Nipple	
2130	0661 1000 43	1	Seal washer	
2139	1503 2565 04	1	Elbow	
2140	0603 4100 17	1	Nipple	
2145	0852 0010 36	1	Ball valve	
2150	0686 3718 24	1	Plug	
2160	1622 6199 00	1	Block	
2165	0663 3128 00	1	O-ring	
2170	0147 1341 03	3	Bolt	
2175	0301 2335 00	3	Washer	
2180	1622 0351 01	1	Oil separator	
2185	1622 0338 00	1	Coupling	
2190	1622 0337 00	1	Pipe	
2195	0571 0035 93	1	Nipple	
2200	0663 3119 00	1	O-ring	
2210	0581 1200 37	1	Coupling	
2215	0070 6002 05	AR	Plastic tube	
2220	0581 0001 02	1	Nipple	
2221	0661 1000 40	1	Seal washer	
2225	0562 3106 03	1	Bend	
2226	0571 0035 28	1	Nipple	
2235	1613 6883 03	1	Valve housing	
2240	0147 1362 03	2	Bolt	
2245	0301 2344 00	2	Washer	
2250	1613 6105 01	1	Oil filter	
2255	1619 3770 00	1	Nipple	
2260	1614 6118 00	1	Flange	
2265	0663 2101 95	1	O-ring	
2270	0147 1246 03	2	Bolt	
2275	0301 2321 00	2	Washer	
2280	0571 0035 97	4	Nipple	
2285	0663 2113 37	4	O-ring	
3010	1622 6553 00	1	Housing	
3015	0661 1000 60	1	Seal washer	
3020	1513 0063 00	1	Spring	
3025	1513 0402 01	1	Piston	
3030	0663 2105 40	1	O-Ring	
3035	1513 0064 00	1	Spring	
3040	1513 0401 01	1	Valve disc	
4015		1	Safety valve	
	0832 1000 77		7.5bar(e)	
	0832 1000 78		8.5bar(e)	
	0832 1000 78		10bar(e)	
	0832 1000 79		13bar(e)	
	0830 1008 35		100psig	

11

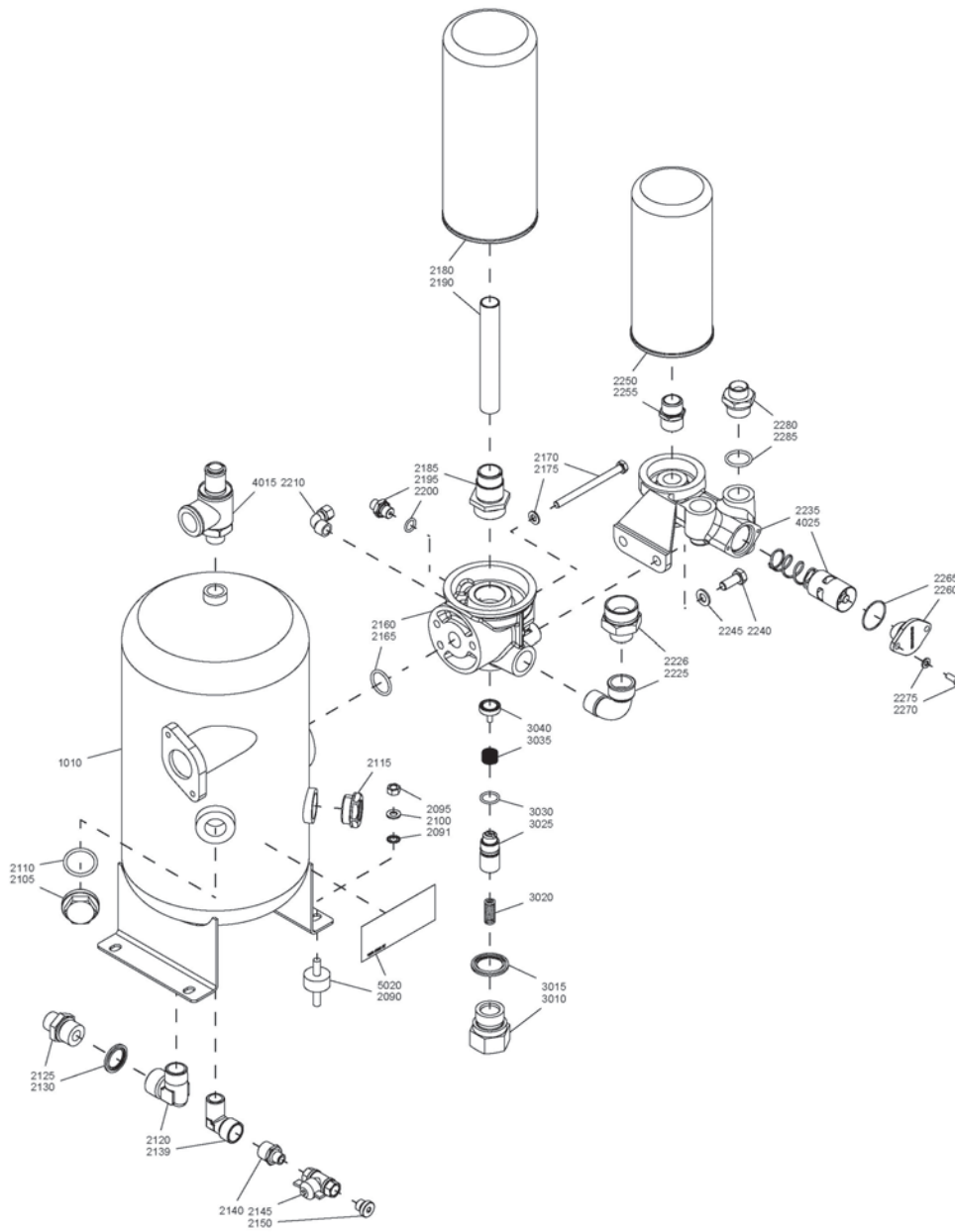

**Oil system - Oil vessel connections****11**

Ref.	Part number	Qty	Name	Remarks
	0830 1008 35		125psig	
	0830 1008 38		150psig	
	0830 1008 38		175psig	
4025		1	Thermostatic valve	
	1622 7064 01		7.5bar(e) 38°C	
	1622 7064 01		8.5bar(e) 38°C	
	1622 7064 01		10bar(e) 38°C	
	1622 7064 02		13bar(e) 65°C	
	1622 7064 01		100psig 38°C	
	1622 7064 01		125psig 38°C	
	1622 7064 01		150psig 38°C	
	1622 7064 02		175psig 65°C	
5020		1	Label	
	1079 9909 57		Roto-Inject Fluid	
	1079 9925 87		Roto-Xtend Duty Fluid	

12

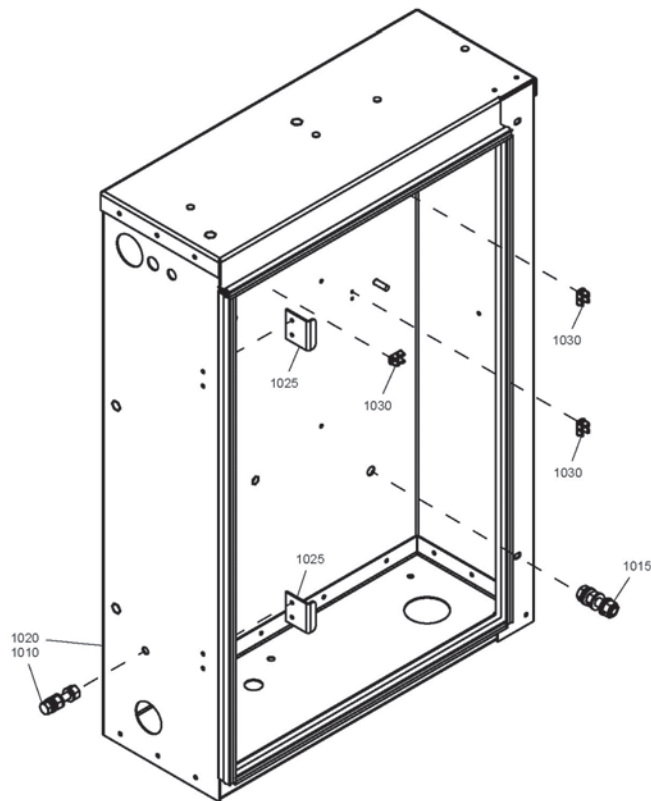
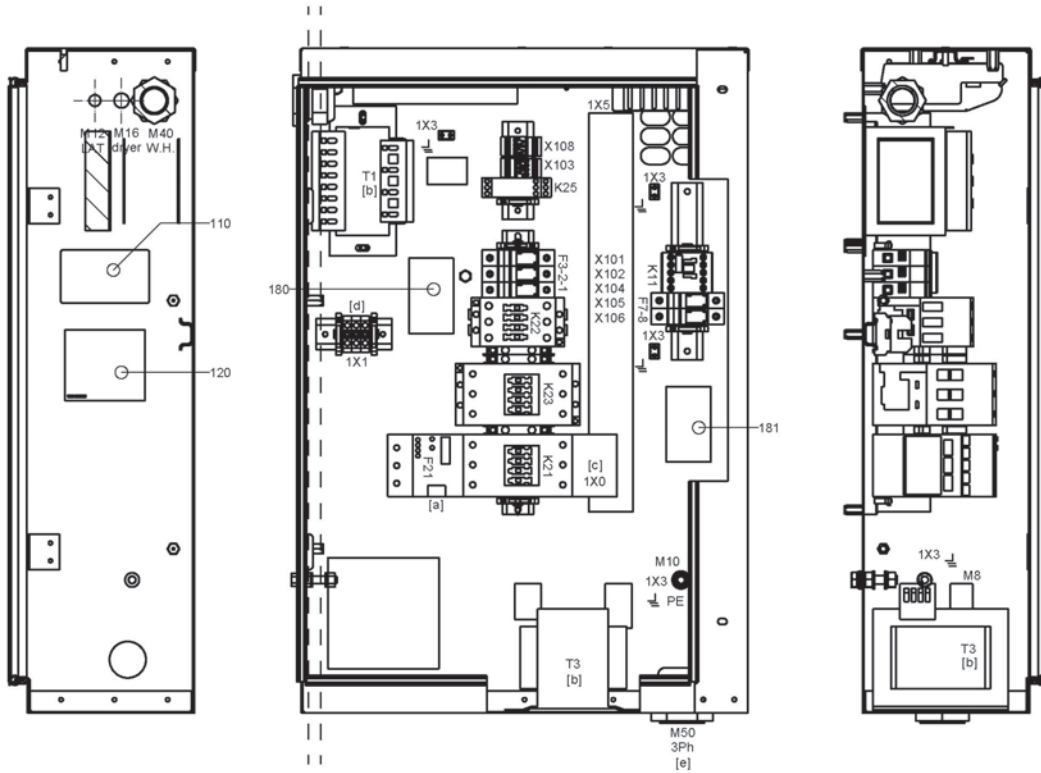

## Cubicle - IEC

12

Ref.	Part number	Qty	Name	Remarks
		<b>1</b>	<b>Cubicle</b>	
	1900 2278 05		GA 15 200V/50Hz IEC	
	1900 2278 04		GA 15 230V/50Hz IEC	
	1900 2278 03		GA 15 380V/60Hz IEC	
	1900 2278 01		GA 15 400V/50Hz IEC	
	1900 2278 02		GA 15 400V/50Hz IEC	
	1900 2278 03		GA 15 500V/50Hz IEC	
	1900 2278 06		GA 18 200V/50Hz IEC	
	1900 2278 05		GA 18 230V/50Hz IEC	
	1900 2278 04		GA 18 380V/60Hz IEC	
	1900 2278 01		GA 18 400V/50Hz IEC	
	1900 2278 02		GA 18 400V/50Hz IEC	
	1900 2278 03		GA 18 500V/50Hz IEC	
	1900 2278 06		GA 22 200V/50Hz IEC	
	1900 2278 06		GA 22 230V/50Hz IEC	
	1900 2278 05		GA 22 380V/60Hz IEC	
	1900 2278 04		GA 22 500V/50Hz IEC	
	1900 2815 18	•	<b>Basic module</b>	
For wh	0697 9809 22	••	1 Nut	
For supply	0697 9809 25	••	1 Nut	
For supply	0698 5140 76	••	1 Cable gland	
120	1079 9925 69	••	1 Label	
X101	1088 0015 02	••	1 Connector	
X101	1088 0015 36	••	2 Connector socket	
X103-X108	1088 0031 18	••	4 Adaptor	
X106	1088 0031 22	••	1 Connector	
2X30	1088 0031 32	••	1 Connector	
X132	1088 0031 43	••	1 Connector	
X106	1088 0031 82	••	1 Connector	
X103	1088 0031 84	••	1 Connector	
X103	1088 0037 04	••	1 Connector	
X105-1X5	1088 0037 30	••	2 Connector	
X104	1088 0037 31	••	1 Connector	
S3	1089 0362 51	••	1 Emergency stop button	
-	1089 0577 58	••	1 End retainer	
X102	1089 0700 02	••	1 Connector	
X102	1089 0700 04	••	8 Connector socket	
S3	1089 9337 13	••	2 Contact block	
110	1622 7302 00	••	1 Data label	
X108	1088 0031 83	••	1 Connector	
X108	1088 0037 03	••	1 Connectorfe	
		•	<b>1 Starter module</b>	
	1900 2822 09		1900 2278 01	
	1900 2823 02		1900 2278 02	
	1900 2822 08		1900 2278 03	
	1900 2823 02		1900 2278 04	
	1900 2823 08		1900 2278 05	
	1900 2824 02		1900 2278 06	
L=320mm	0090 1400 02	••	1 Mounting rail	
K22-K23				

12

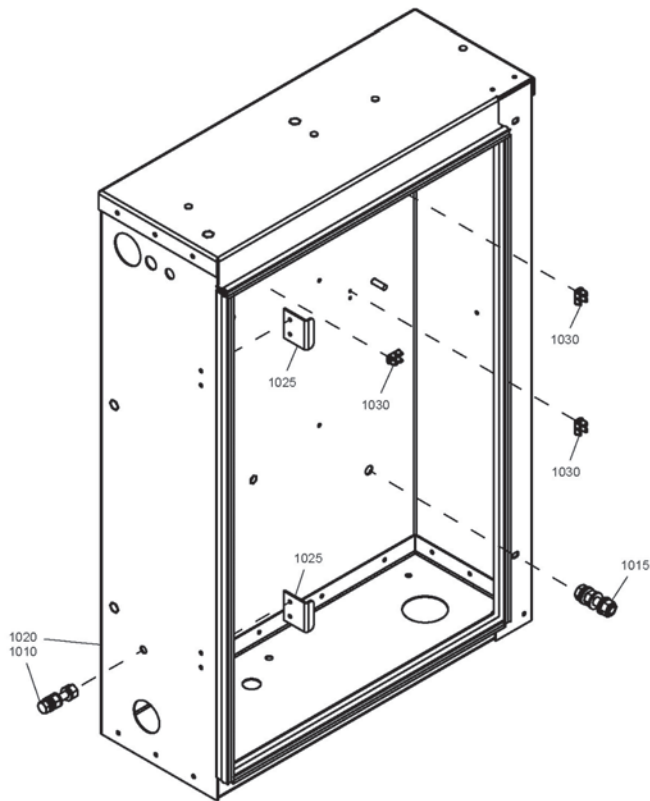
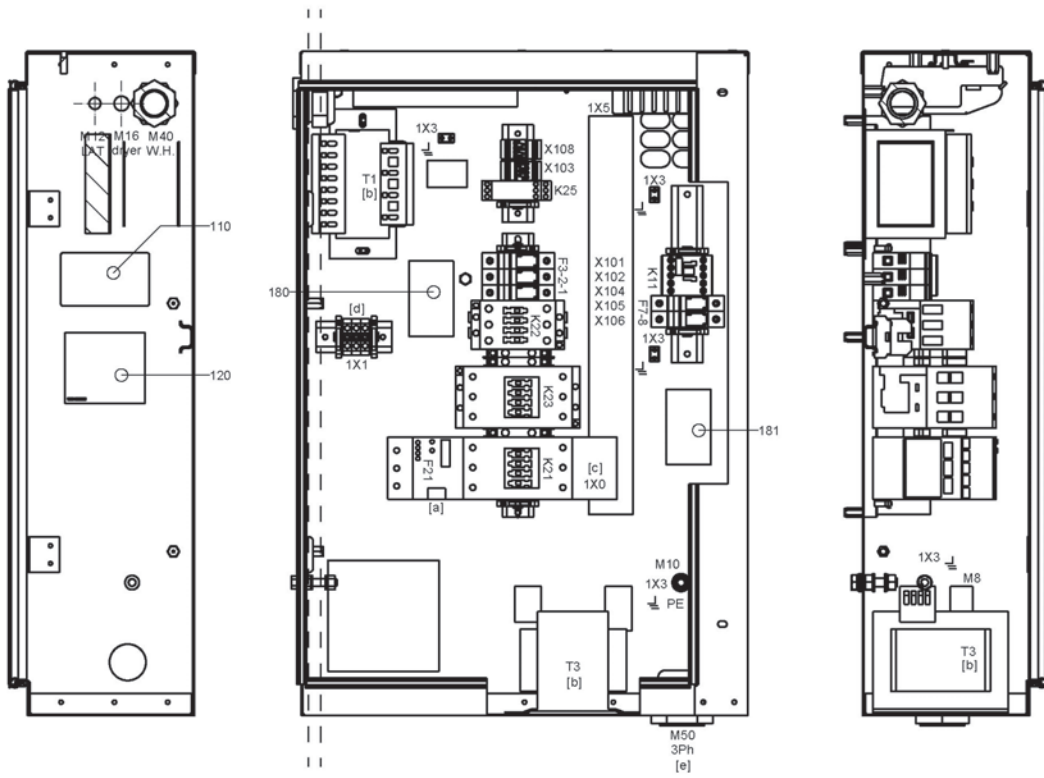

## Cubicle - IEC

12

Ref.	Part number	Qty	Name	Remarks
	0694 5285 12	••	9	Isolator cap
K22-K23		••	6	Fork faston male
	0694 5900 10			1900 2822 09
	0694 5900 10			1900 2822 08
K23		••	3	Double faston
	1088 0004 20			1900 2822 09
	1088 0004 20			1900 2822 08
	1088 0004 20			1900 2823 02
	1088 0004 20			1900 2823 08
starter rail ends				
	1089 0577 58	••	2	End retainer
X102	1089 0700 01	••	1	Connector
X102	1089 0700 03	••	8	Connector pin
K22	1089 9415 09	••	1	Contact block
K22		••	1	Contacting
	1089 9415 24			1900 2822 09
	1089 9415 24			1900 2822 08
	1089 9415 26			1900 2823 02
	1089 9415 26			1900 2823 08
	1089 9415 34			1900 2824 02
K21-K23		••	2	Contacting
	1089 9415 26			1900 2822 09
	1089 9415 26			1900 2822 08
	1089 9415 34			1900 2823 02
	1089 9415 34			1900 2823 08
	1089 9415 44			1900 2824 02
K21	1089 9415 55	••	1	Contact block
K23	1089 9415 56	••	1	Contact block
1X0:L123onK21		••	1	Terminal block
	1089 9416 05			1900 2822 09
	1089 9416 05			1900 2822 08
	1089 9416 93			1900 2823 02
	1089 9416 93			1900 2823 08
1X0:L123onK21		••	3	Connection element
	1622 1692 00			1900 2824 02
F21		••	1	Over load relay
	1089 9424 31			1900 2822 09
	1089 9424 30			1900 2822 08
	1089 9424 39			1900 2823 02
	1089 9424 40			1900 2823 08
	1089 9424 46			1900 2824 02
K23		••	3	Faston flat
	0694 5900 06			1900 2823 02
	0694 5900 06			1900 2823 08
K22		••	3	Fork faston
	0694 5900 10			1900 2823 02
	0694 5900 10			1900 2823 08
K22-K23		••	6	Faston flat
	0694 5900 06			1900 2824 02
K21		••	3	Angled faston flat
	0694 5900 07			1900 2824 02
1X0:L123onK21		••	1	Terminal cover
	1089 9362 04			1900 2824 02
Set of plastic bag		••	3	CableLug

12

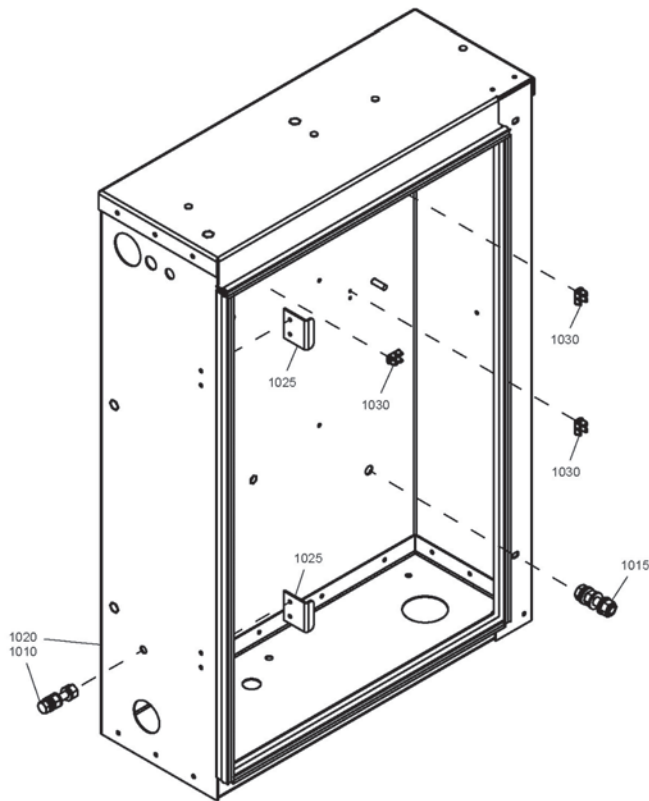
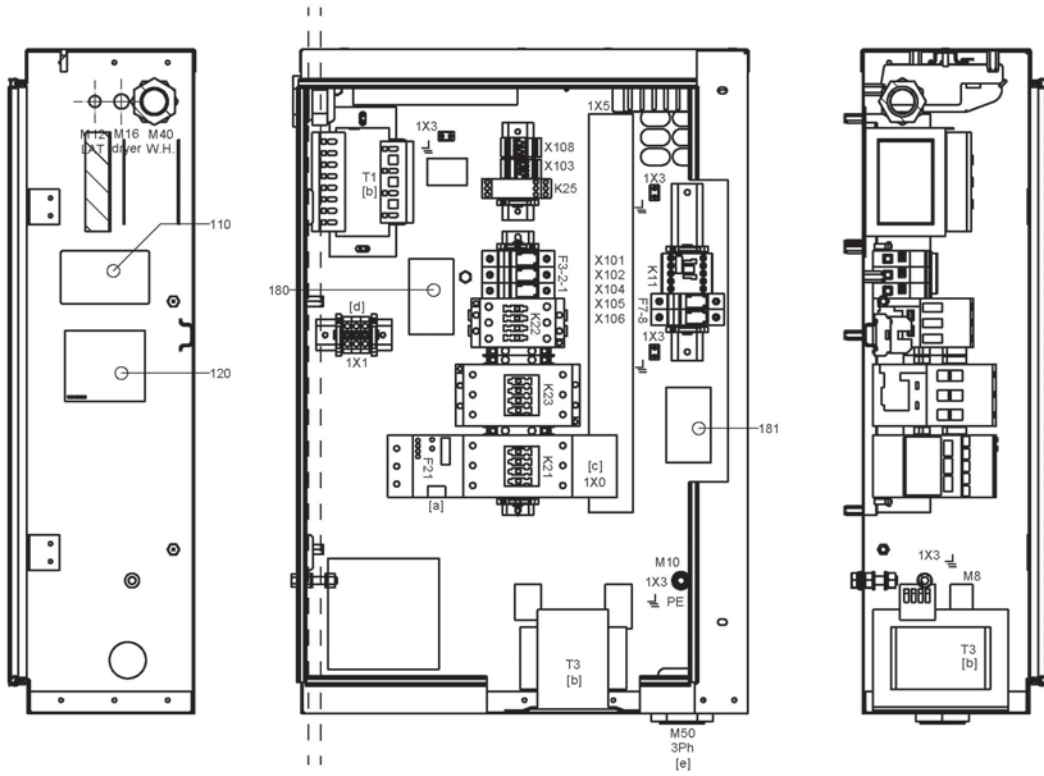



## Cubicle - IEC

12

Ref.	Part number	Qty	Name	Remarks
	0694 5281 34		1900 2824 02	
	•	1	<b>Transfo module</b>	
	<b>1900 2830 02</b>		1900 2278 01	
	<b>1901 2830 02</b>		1900 2278 02	
	<b>1902 2830 02</b>		1900 2278 03	
	<b>1903 2830 02</b>		1900 2278 04	
	<b>1900 2830 09</b>		1900 2278 05	
	<b>1900 2830 09</b>		1900 2278 06	
F1-F2	1089 0612 01	••	2	Fuse holder
F1-F2		••	2	Fuse
	1089 0612 23		1900 2830 02	
	1089 0612 24		1901 2830 09	
T1		••	1	Transformer
	1089 9436 38		1900 2830 02	
	1089 9436 44		1901 2830 09	
WH	1622 4102 10	•	1	Wire harness
	<b>1622 4754 80</b>	•	1	<b>Cubicle</b>
1010	1622 3115 50	••	1	Bolt
1015	1622 3115 51	••	1	Bolt
1020		••	1	Cubicle
1025	1622 4754 03	••	2	Plate
1030	0694 5900 05	••	3	Tab

13

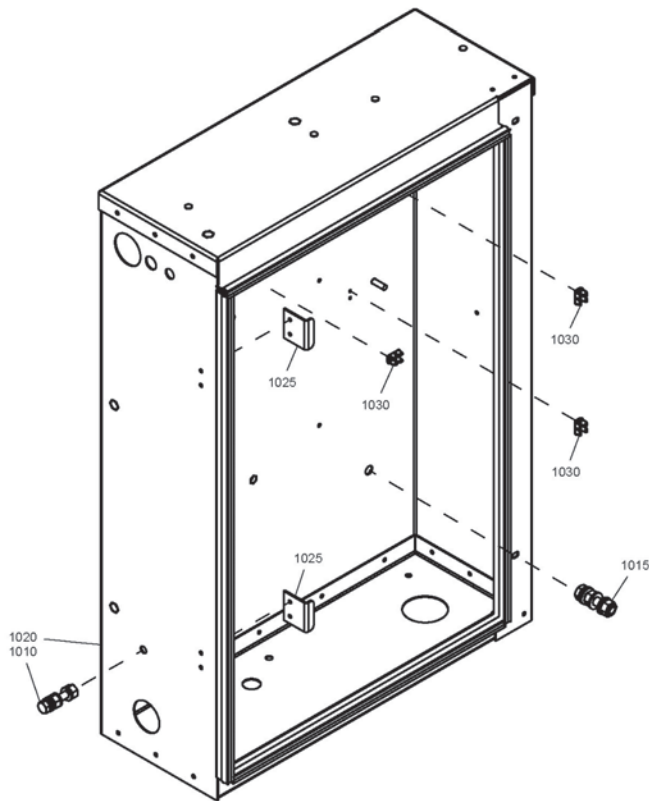
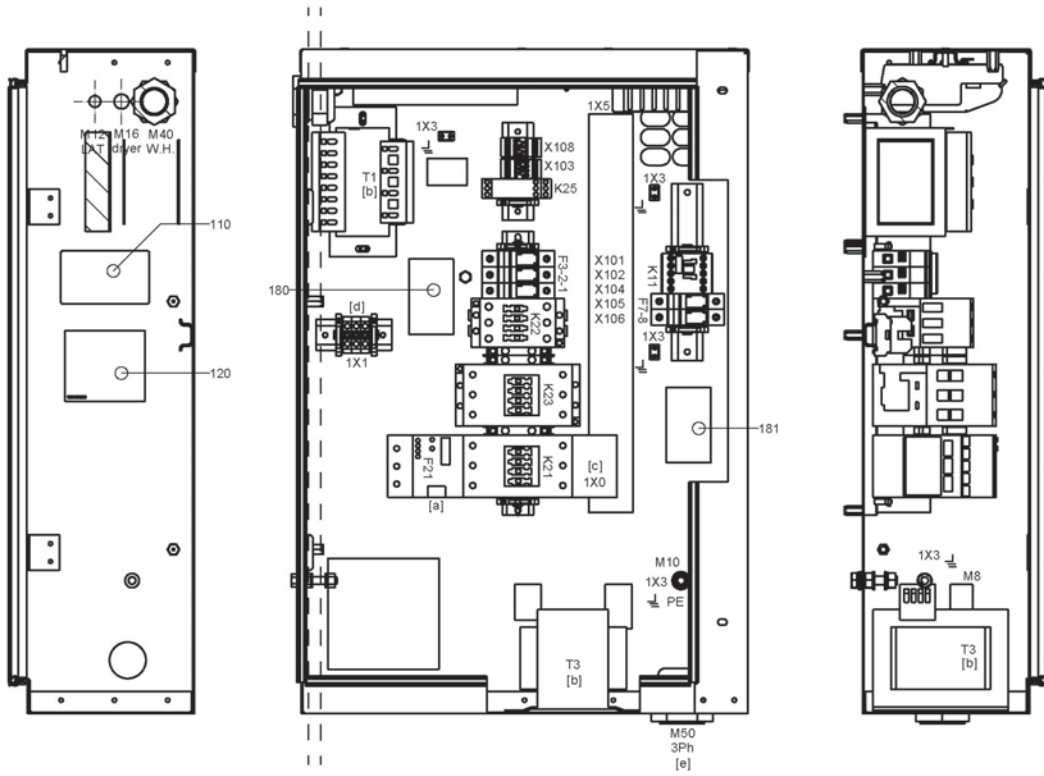

## Cubicle - UL-cUL

13

Ref.	Part number	Qty	Name	Remarks
		<b>1</b>	<b>Cubicle</b>	
	<b>1900 2278 50</b>		GA 15 200V-230V-460V/60Hz UL-cUL	
	<b>1900 2278 53</b>		GA 15 440V-460V-575V/60Hz UL-cUL	
	<b>1900 2278 51</b>		GA 18 200V-230V-460V/60Hz UL-cUL	
	<b>1900 2278 54</b>		GA 18 440V-460V/60Hz UL-cUL	
	<b>1900 2278 53</b>		GA 18 575V/60Hz UL-cUL	
	<b>1900 2278 52</b>		GA 22 200V-230V-460V/60Hz UL-cUL	
	<b>1900 2278 54</b>		GA 22 440V-460V-575V/60Hz UL-cUL	
	<b>1900 2815 19</b>	<b>•</b>	<b>Basic module</b>	
forwh	0697 9809 22	<b>••</b>	1 Nut	
forsupply	0697 9809 25	<b>••</b>	1 Nut	
forsupply	0698 5140 76	<b>••</b>	1 Cable gland	
120	1079 9925 69	<b>••</b>	1 Label	
X101	1088 0015 02	<b>••</b>	1 Connector	
X101	1088 0015 36	<b>••</b>	2 Connector socket	
X103-X108	1088 0031 18	<b>••</b>	4 Adaptor	
X106	1088 0031 22	<b>••</b>	1 Connector	
2X30	1088 0031 32	<b>••</b>	1 Connector	
X132	1088 0031 43	<b>••</b>	1 Connector	
X106	1088 0031 82	<b>••</b>	1 Connector	
X103	1088 0031 84	<b>••</b>	1 Connector	
X108	1088 0031 86	<b>••</b>	1 Connector	
X103	1088 0037 04	<b>••</b>	1 Connector	
X108	1088 0037 06	<b>••</b>	1 Connector	
X105-1X5	1088 0037 30	<b>••</b>	2 Connector	
X104	1088 0037 31	<b>••</b>	1 Connector	
S3	1089 0362 51	<b>••</b>	1 Emergency stop button	
-	1089 0577 58	<b>••</b>	1 End retainer	
X102	1089 0700 02	<b>••</b>	1 Connector	
X102	1089 0700 04	<b>••</b>	8 Connector socket	
S3	1089 9337 13	<b>••</b>	2 Contact block	
190	1613 3431 00	<b>••</b>	1 Label	
110	1622 7302 00	<b>••</b>	1 Data-label	
123	1622 7303 00	<b>••</b>	1 Data-label	
		<b>•</b>	<b>1 Rail 1X1</b>	
L=85mm	0090 1400 02	<b>••</b>	1 Mounting rail	
1X1:T4..T9	1089 0506 09	<b>••</b>	3 Terminal	
-	1089 0577 58	<b>••</b>	2 End retainer	
		<b>•</b>	<b>1 Starter module</b>	
	<b>1900 2823 10</b>		1900 2278 50	
	<b>1900 2824 04</b>		1900 2278 51	
	<b>1900 2824 11</b>		1900 2278 52	
	<b>1900 2822 07</b>		1900 2278 53	
	<b>1900 2823 01</b>		1900 2278 54	
L=320mm	0090 1400 02	<b>••</b>	1 Mounting rail	
K22-K23		<b>••</b>	Isolator cap	
	0694 5285 12	<b>••</b>	9 1900 2823 10	

13

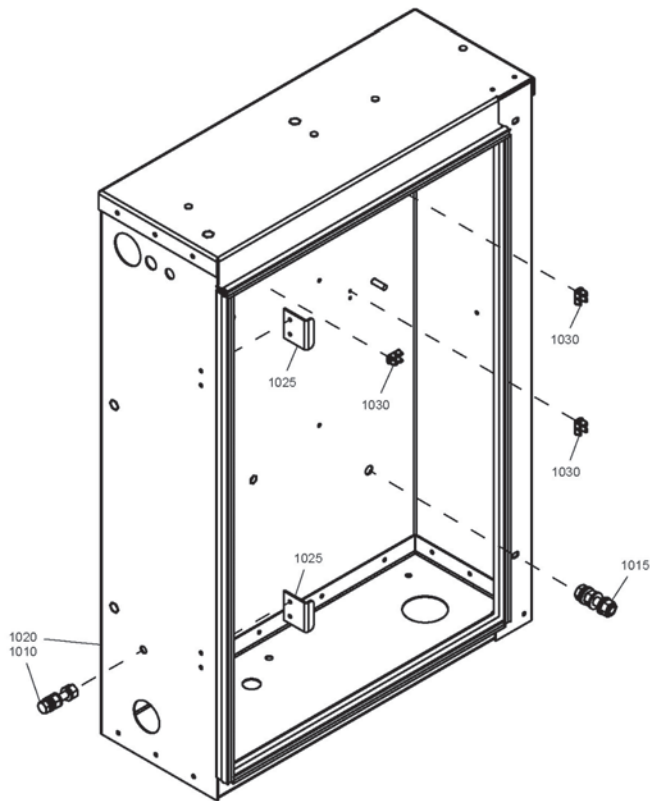
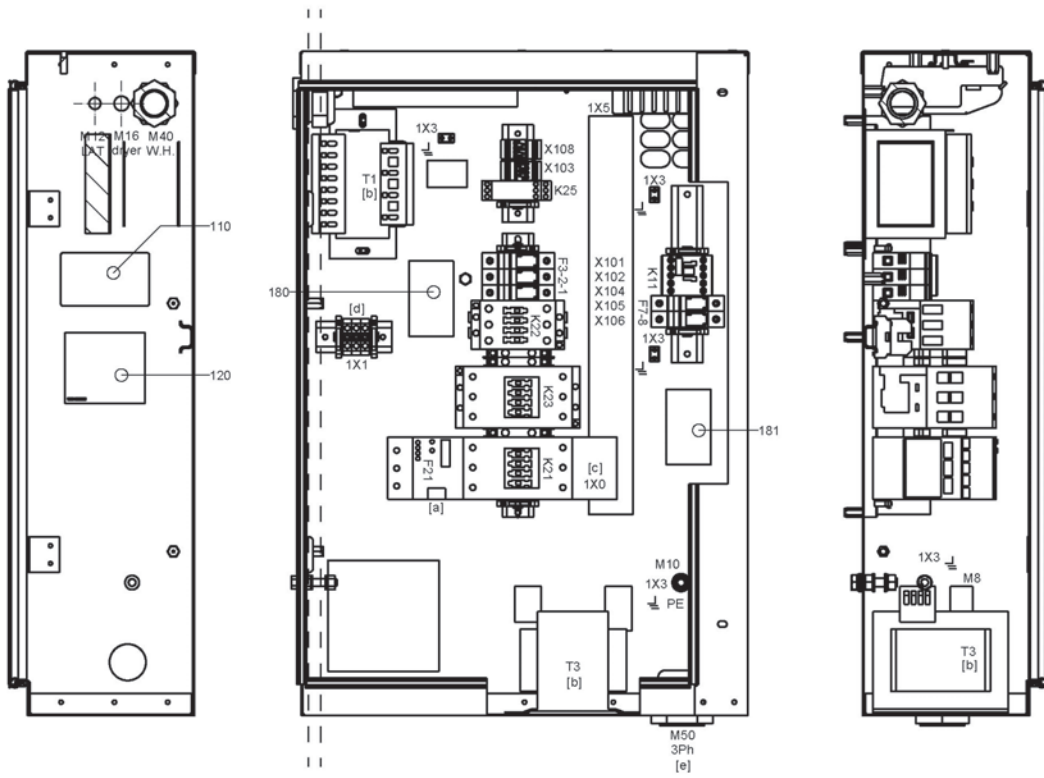

## Cubicle - UL-cUL

13

Ref.	Part number	Qty	Name	Remarks
	0694 5285 12	6	1900 2824 04	
	0694 5285 12	6	1900 2824 11	
	0694 5285 12	9	1900 2822 07	
	0694 5285 12	9	1900 2823 01	
K23	••	3	Faston flat	
	0694 5900 06		1900 2823 10	
	0694 5900 06		1900 2823 01	
K22-K23	••	6	Faston flat	
	0694 5900 06		1900 2824 04	
	0694 5900 06		1900 2824 11	
	0694 5900 10		1900 2822 07	
K22	••	3	Fork faston	
	0694 5900 10		1900 2823 10	
	0694 5900 10		1900 2823 01	
K23	••	3	Double faston	
	1088 0004 20		1900 2823 10	
	1088 0004 20		1900 2822 07	
	1088 0004 20		1900 2823 01	
Starter rail ends				
	1089 0577 58	••	2	End retainer
X102	1089 0700 01	••	1	Connector
X102	1089 0700 03	••	8	Connector pin
K22	1089 9415 09	••	1	Contact block
K22	••	1	Contact	
	1089 9415 26		1900 2823 10	
	1089 9415 34		1900 2824 04	
	1089 9415 36		1900 2824 11	
	1089 9415 24		1900 2822 07	
	1089 9415 26		1900 2823 01	
K21-K23	••	2	Contact	
	1089 9415 36		1900 2823 10	
	1089 9415 44		1900 2824 04	
	1089 9415 45		1900 2824 11	
	1089 9415 26		1900 2822 07	
	1089 9415 34		1900 2823 01	
K21	1089 9415 55	••	1	Contact block
K23	1089 9415 56	••	1	Contact block
1X0:L123onK21	••	1	Terminal block	
	1089 9416 93		1900 2823 10	
	1089 9416 05		1900 2822 07	
	1089 9416 93		1900 2823 01	
1X0:L123onK21	••	3	Connection element	
	1622 1692 00		1900 2824 04	
	1622 1692 00		1900 2824 11	
F21	••	1	Over load relay	
	1089 9446 61		1900 2823 10	
	1089 9446 65		1900 2824 04	
	1089 9446 66		1900 2824 11	
	1089 9424 29		1900 2822 07	
	1089 9424 38		1900 2823 01	
K21	••	3	Angled faston flat	
	0694 5900 07		1900 2824 04	
	0694 5900 07		1900 2824 11	

13

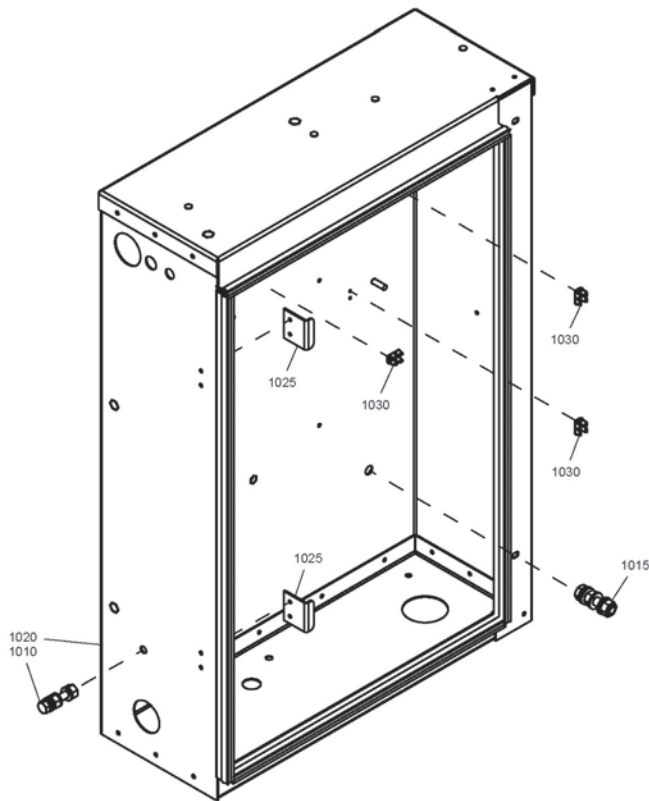
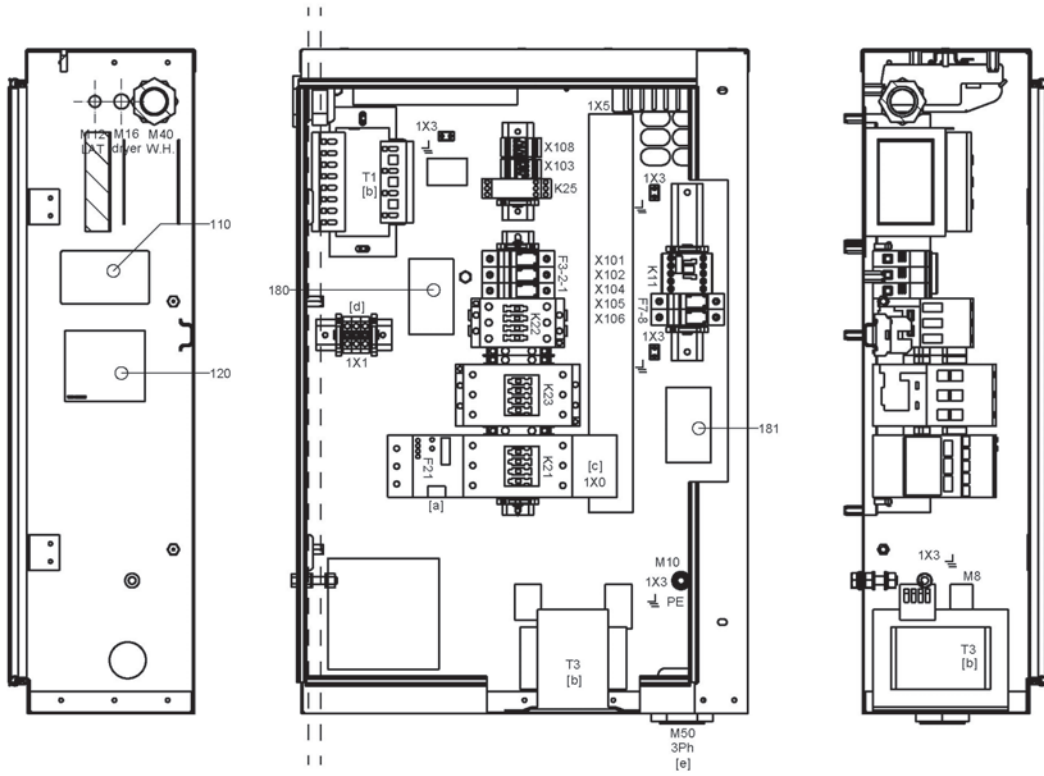

## Cubicle - UL-cUL

13

Ref.	Part number	Qty	Name	Remarks
1X0:L123onK21	••	1	Terminal cover	
	1089 9362 04		1900 2824 04	
	1089 9362 04		1900 2824 11	
Sets of plastic bags	••	3	Cable lug	
	0694 5281 34		1900 2824 04	
	0694 5281 34		1900 2824 11	
	•	1	<b>Transfo module</b>	
	<b>1900 2830 15</b>		1900 2278 50	
	<b>1900 2830 15</b>		1900 2278 51	
	<b>1900 2830 15</b>		1900 2278 52	
	<b>1900 2830 14</b>		1900 2278 53	
	<b>1900 2830 14</b>		1900 2278 54	
180	••	1	Label	
	1079 9924 26		1900 2278 50	
	1079 9924 26		1900 2278 51	
	1079 9924 26		1900 2278 52	
	1079 9924 27		1900 2278 53	
	1079 9924 27		1900 2278 54	
F1-F2	••	2	Fuse link	
	1089 9168 26		1900 2278 50	
	1089 9168 26		1900 2278 51	
	1089 9168 26		1900 2278 52	
	1089 9168 24		1900 2278 53	
	1089 9168 24		1900 2278 54	
T1	••	1	Transformer	
	1089 9436 44		1900 2278 50	
	1089 9436 44		1900 2278 51	
	1089 9436 44		1900 2278 52	
	1089 9436 43		1900 2278 53	
	1089 9436 43		1900 2278 54	
F1-F2	1089 0612 01	••	2	Fuse holder
WH	1622 4102 10	•	1	Wire harness
	<b>1622 4754 80</b>	•	1	<b>Cubicle</b>
1010	1622 3115 50	••	1	Bolt
1015	1622 3115 51	••	1	Bolt
1020		••	1	Cubicle
1025	1622 4754 03	••	2	Plate
1030	0694 5900 05	••	3	Tab
1040	0129 3115 00	••	30	Blind rivet
1045	0129 3270 34	••	6	Blind rivet
1050	1622 4754 04	••	1	Cubicle roof
1055	1622 4754 05	••	1	Cubicle bottom
1060	0298 1000 73	••	8	Rivet
1070	0298 1000 74	••	6	Rivet
1075	0160 0996 83	••	2	Screw
1080	0333 0500 12	••	4	Washer





## Bodywork - Pack

14

Ref.	Part number	Qty	Name	Remarks
<b>1010</b>	<b>1622 4730 80</b>	<b>1</b>	<b>Frame</b>	
1011	1079 9903 48 •	1	Decal	
<b>1015</b>	<b>1622 4727 80</b>	<b>1</b>	<b>Panel</b>	1)
1020	0147 1964 29	2	Hexagon bolt	
<b>1025</b>	<b>1622 4795 80</b>	<b>1</b>	<b>Panel</b>	1)
1030	0147 1964 29	2	Hexagon bolt	
<b>1035</b>	<b>1622 4794 80</b>	<b>1</b>	<b>Roof</b>	1)2)
1040	0215 0006 14	6	Screw	
<b>1045</b>	<b>1624 2557 80</b>	<b>1</b>	<b>Panel</b>	1)
1050	0215 0006 14	3	Screw	
<b>1055</b>	<b>1622 4746 80</b>	<b>1</b>	<b>Panel</b>	1)
1060	0215 0006 14	6	Screw	
<b>1065</b>	<b>1622 8522 80</b>	<b>1</b>	<b>Cubicle door</b>	1)
1066	1619 7705 00 •	2	Lock	
1067	1088 1001 01 •	1	Warning mark	
1068	1079 9920 83 •	1	Decal	
1070	1202 6400 00	2	Hinge	
1075	0147 1244 03	2	Hexagon bolt	
1080	0301 2321 00	2	Washer	
<b>1085</b>	<b>1622 4742 80</b>	<b>1</b>	<b>Panel</b>	1)
1086	1513 0431 00 •	2	Door lock	
1090	1089 9154 02	1	Key	
1095	1089 9068 01	1	Key	
1100	1088 1301 02	1	Cable strip	
1110	1622 3880 80	1	Document holder	
<b>2018</b>	<b>1089 9556 05</b>	<b>1</b>	<b>Air Inlet Filter</b>	
	1089 9556 23 •	1	Filter	
2020	1900 5200 01	1	Elektronikon® Mk5	
2025	0147 1169 03	6	Hexagon bolt	
2030	0301 2315 00	6	Washer	
2035	1089 9125 05	1	Round disk	
3005	1088 1001 01	1	Warning mark	
3010	1088 1001 02	1	Warning mark	
3020		1	Decal	
	1622 4631 39		GA15	
	1622 4631 41	1	GA18	
	1622 4631 43	1	GA22	
3025	1622 1900 24	2	Data label	
3030	1622 3274 00	1	Decal	
3040	0690 1125 01	1	House mark	
3045	1622 6116 00	1	Warning label	
3050	1079 9915 89	1	Label	
3055	1079 9915 98	1	Label	
4010	1089 0362 51	1	Push button	

1-2) Lined with:

- 1) Foam: 0395 6001 66 (AR) 25 x 2040 x 1650-self-adhesive
- 2) Foam: 0395 6006 69 (AR) 50 x 2040 x 1650-self-adhesive

15

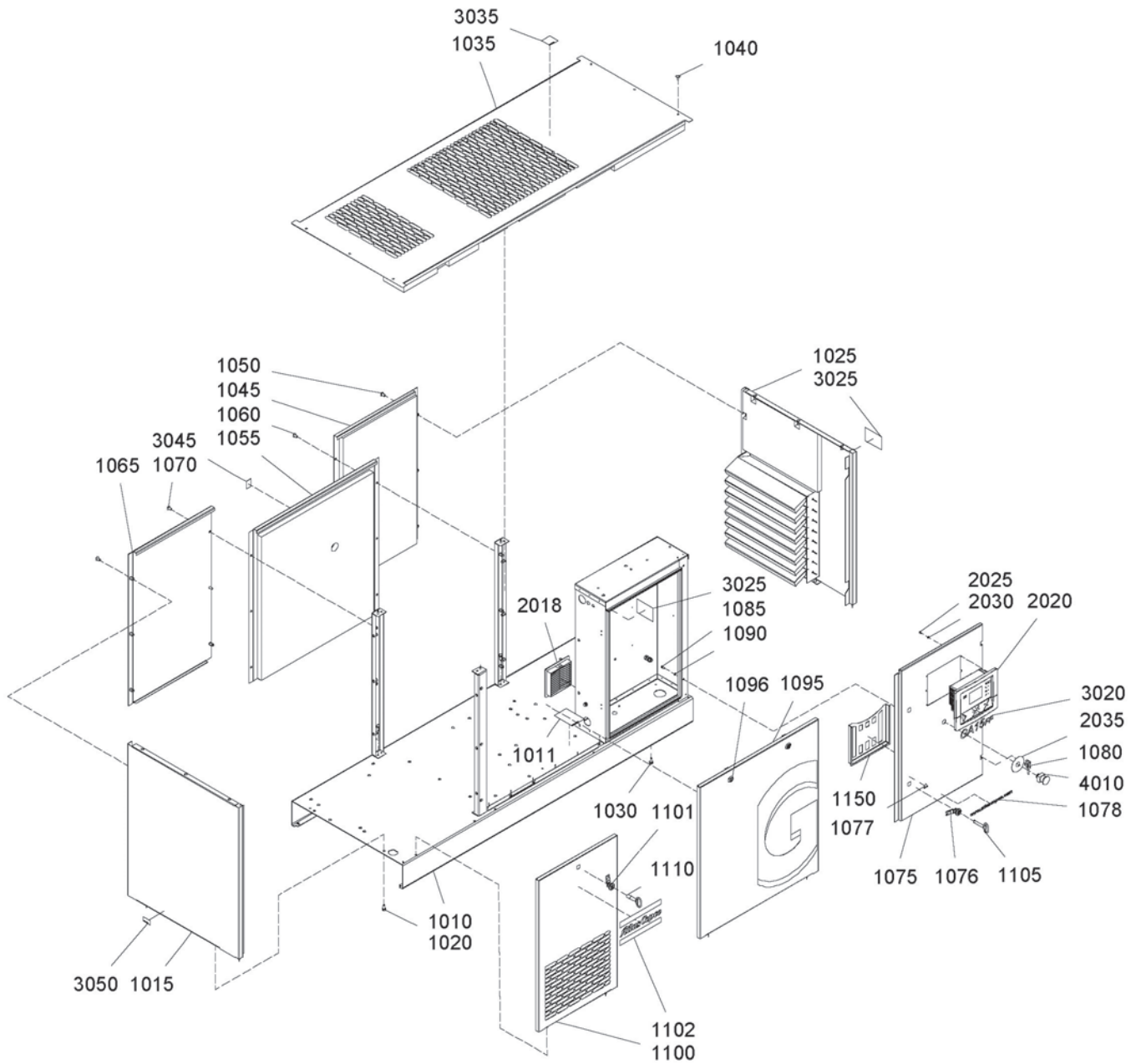

## Bodywork - Full Feature

15

Ref.	Part number	Qty	Name	Remarks
<b>1010</b>	<b>1622 4731 80</b>	<b>1</b>	<b>Frame</b>	
1011	1079 9903 48 •	1	Label	
<b>1015</b>	<b>1622 4727 81</b>	<b>1</b>	<b>Panel</b>	1)
1020	0147 1964 29	2	Hexagon bolt	
<b>1025</b>	<b>1622 4795 80</b>	<b>1</b>	<b>Panel</b>	1)
1030	0147 1964 29	2	Hexagon bolt	
<b>1035</b>	<b>1622 4792 80</b>	<b>1</b>	<b>Roof</b>	1)2)
1040	0215 0006 14	6	Screw	
<b>1045</b>	<b>1622 4746 80</b>	<b>1</b>	<b>Panel</b>	1)
1050	0215 0006 14	3	Screw	
<b>1055</b>	<b>1624 2557 80</b>	<b>1</b>	<b>Back panel</b>	1)
1060	0215 0006 14	3	Screw	
1065	1622 4748 80	1	Pane	
1070	0215 0006 14	6	Hex sock screw	
<b>1075</b>	<b>1622 8522 80</b>	<b>1</b>	<b>Cubicle door</b>	1)
1076	1619 7705 00 •	2	Lock	
1077	1088 1001 01 •	1	Warning mark	
1078	1079 9920 83 •	1	Decal	
1080	1202 6400 00	2	Hinge	
1085	0147 1244 03	2	Hexagon bolt	
1090	0301 2321 00	2	Washer	
<b>1095</b>	<b>1622 4742 80</b>	<b>1</b>	<b>Panel</b>	1)
1096	1513 0431 00 •	2	Door Lock	
<b>1100</b>	<b>1622 4743 80</b>	<b>1</b>	<b>Panel</b>	1)
1101	1513 0431 00 •	1	Door lock	
1102	0690 1125 01 •	1	House mark	
1103	0348 0102 11	5	Cable tie	
1105	1089 9154 02	1	Key	
1110	1089 9068 01	1	Key	
1115	1088 1301 02	1	Cable strip	
<b>2018</b>	<b>1089 9556 05</b>	<b>1</b>	<b>Air inlet filter</b>	
	1089 9556 23 •	1	Filter	
2020	1900 5200 01	1	Elektronikon® Mk5	
2025	0147 1169 03	6	Hexagon bolt	
2030	0301 2315 00	6	Washer	
2035	1089 9125 05	1	Round disk	
3020		1	Decal	
	1622 4631 40		GA15FF	
	1622 4631 42	1	GA18FF	
	1622 4631 44	1	GA22FF	
3025	1622 1900 24	2	Data label	
3030	1622 3274 00	1	Decal	
3035	1079 9902 55	1	Label	
3045	1622 6116 00	1	Warning label	
3050	1079 9915 89	1	Label	
4010	1089 0362 51	1	Push button	

1-2) Lined with:

1) Foam: 0395 6001 66 (AR) 25 x 2040 x 1650-self-adhesive

2) Foam: 0395 6006 69 (AR) 50 x 2040 x 1650-self-adhesive

16

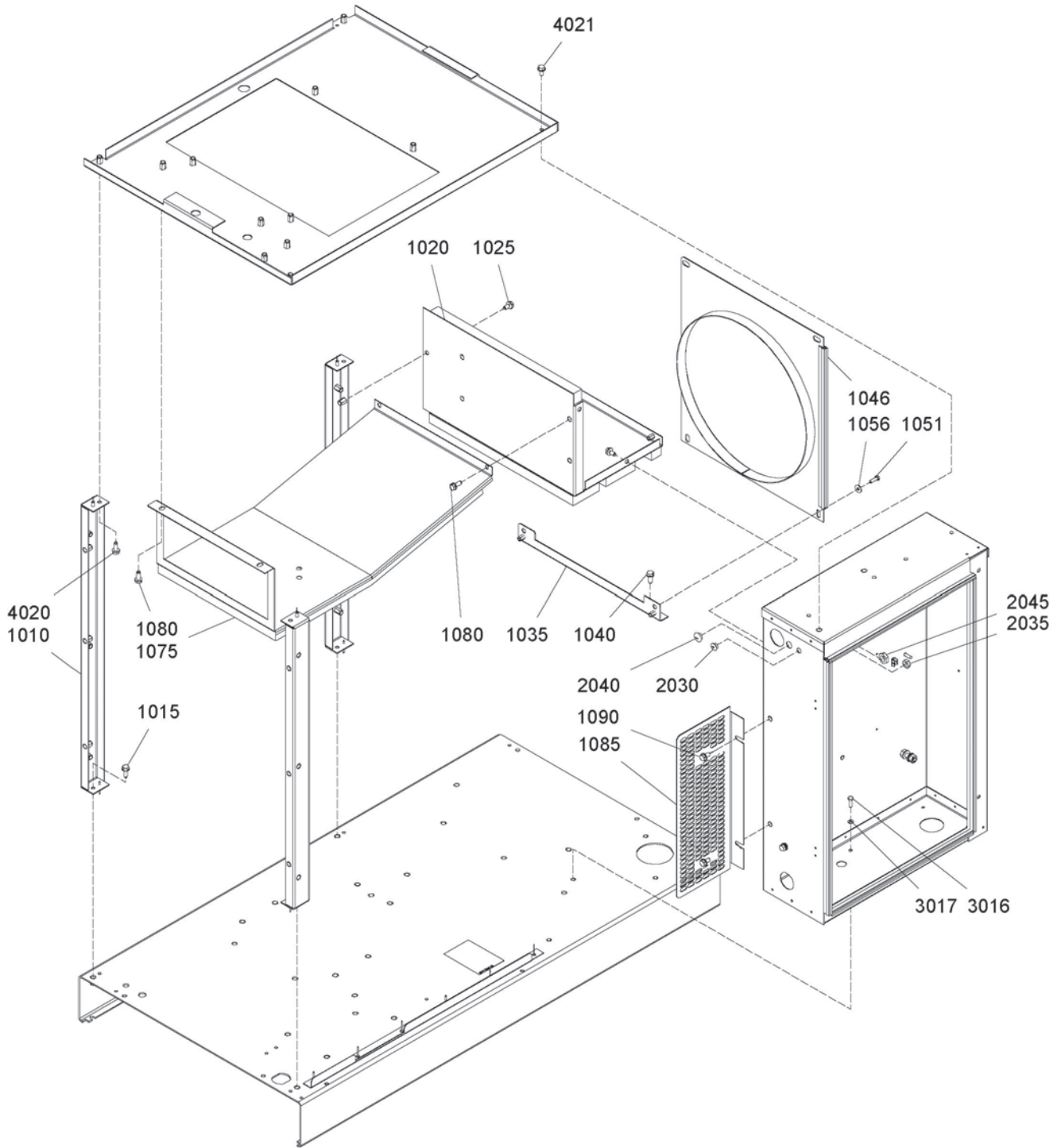

## Bodywork - Pack - Baffles

16

Ref.	Part number	Qty	Name	Remarks
1010	1622 4711 82	3	Beam	
1015	0147 1963 08	3	Hexagon bolt	
<b>1020</b>	<b>1622 8579 80</b>	<b>1</b>	<b>Baffle</b>	1)
1025	1079 1472 05	3	Bolt	
1035	1622 4769 80	1	Baffle	
1040	0147 1963 08	2	Hexagon bolt	
<b>1046</b>	<b>1622 8544 80</b>	<b>1</b>	<b>Baffle</b>	
	1202 6584 00 •	AR	Seal	
1051	0147 1247 03	4	Hexagon bolt	
1056	0300 0276 63	4	Washer	
<b>1075</b>	<b>1622 8529 80</b>	<b>1</b>	<b>Baffle</b>	1)
1080	0147 1963 08	4	Hexagon bolt	
1085	1624 2551 00	1	Plate	
1090	1079 1472 05	2	Bolt	
2030	0697 9810 32	1	Plug	
2035	0697 9809 30	1	Lock nut	
2040	0697 9810 25	1	Plug	
2045	0697 9809 20	1	Lock nut	
3016	0147 1247 03	4	Bolt	
3017	0301 2321 00	4	Washer	
4020	0147 1963 08	3	Bolt	
4021	1079 1472 05	1	Hexagon Bolt	

- 1) Lined with:  
Foam: 0395 6001 66 (AR) 25 x 2040 x 1650-self-adhesive

17

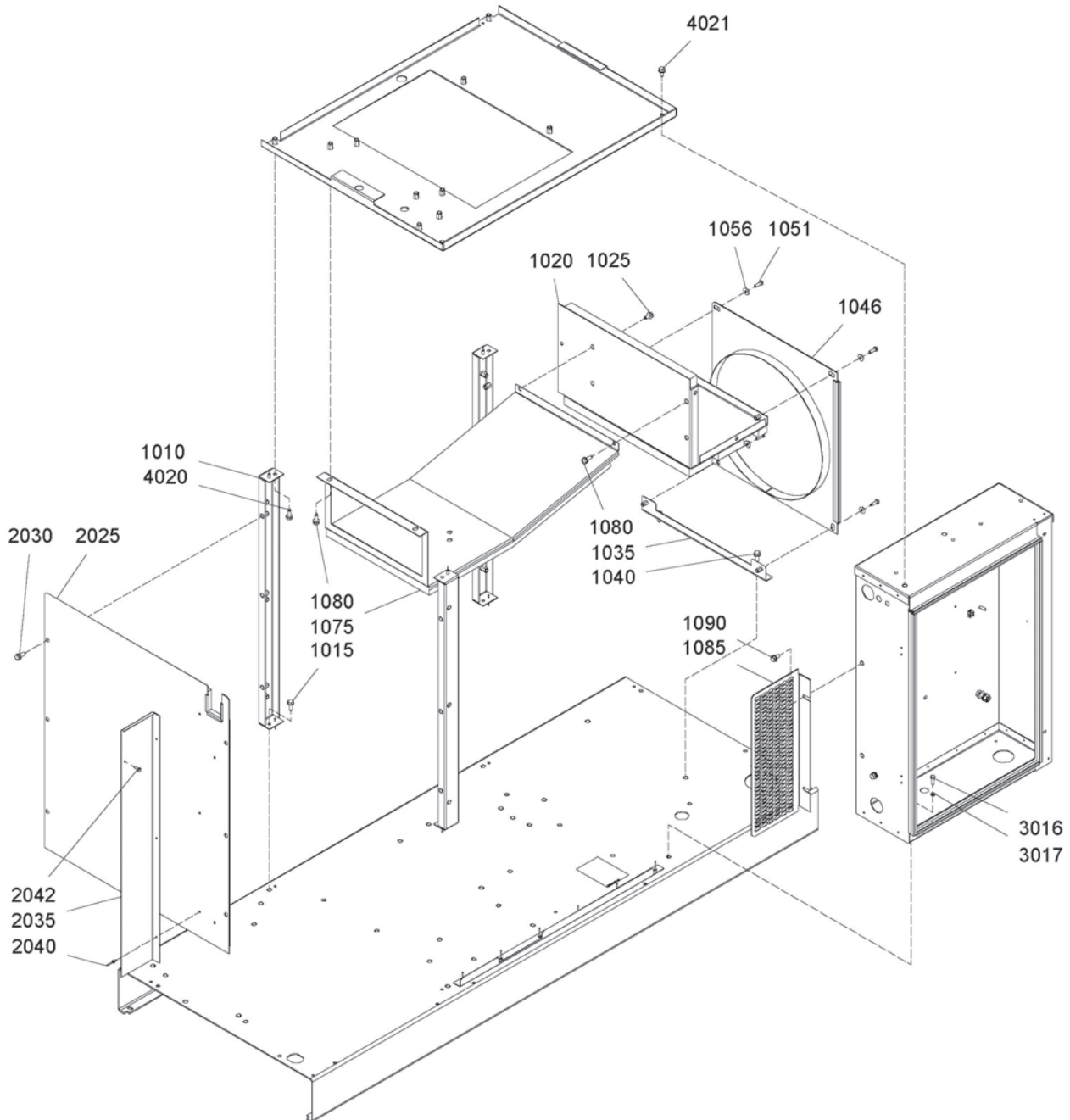

## Bodywork - Full Feature - Baffles

17

Ref.	Part number	Qty	Name	Remarks
1010	1622 4711 82	3	Beam	
1015	0147 1963 08	3	Hexagon bolt	
<b>1020</b>	<b>1622 8579 80</b>	<b>1</b>	<b>Baffle</b>	1)
1025	1079 1472 05	3	Bolt	
1035	1622 4769 80	1	Baffle	
1040	0147 1963 08	2	Hexagon bolt	
<b>1046</b>	<b>1622 8544 80</b>	<b>1</b>	<b>Baffle</b>	
	1202 6584 00 •	AR	Seal	
1051	0147 1247 03	4	Hexagon bolt	
1056	0300 0276 63	4	Washer	
<b>1075</b>	<b>1622 8529 80</b>	<b>1</b>	<b>Baffle</b>	1)
1080	0147 1963 08	4	Hexagon bolt	
1085	1624 2551 00	1	Plate	
1090	1079 1472 05	2	Bolt	
<b>2025</b>	<b>1622 4723 81</b>	<b>1</b>	<b>Plate</b>	1)
2030	0147 1963 08	6	Bolt	
2035	•	1	Plate	
	1622 4777 00		A6X	
	1622 4777 10		A7X	
2040	0129 3270 33	3	Rivet	
3016	0147 1247 03	4	Bolt	
3017	0301 2321 00	4	Washer	
4020	0147 1963 08	3	Bolt	
4021	1079 1472 05	1	Hexagon Bolt	

- 1) Lined with:  
Foam: 0395 6001 66 (AR) 25 x 2040 x 1650-self-adhesive

18

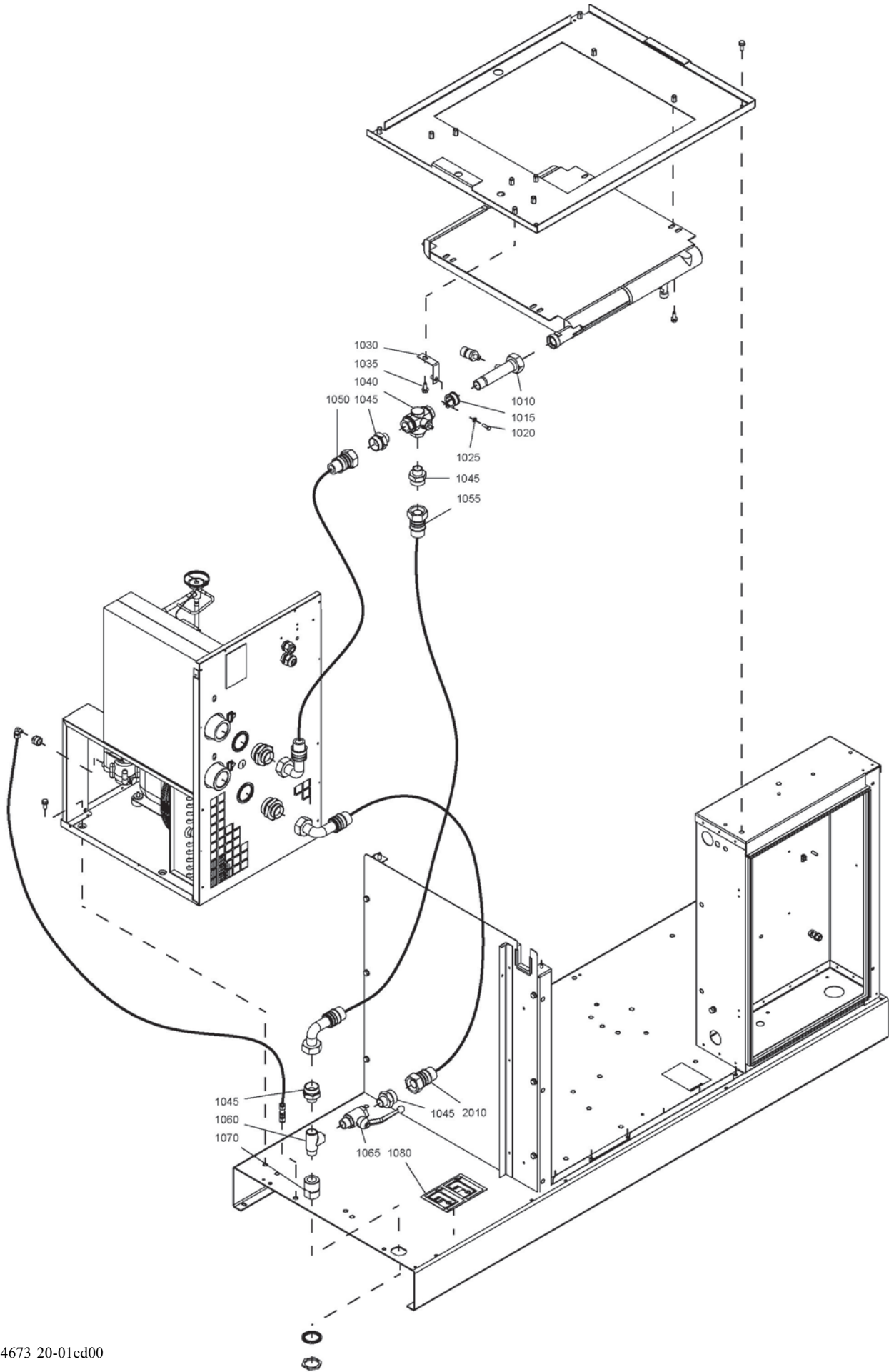



## Standard option - Air dryer - Bypass

18

Ref.	Part number	Qty	Name	Remarks
	<b>8092 2908 01</b>	<b>1</b>	<b>Standard option</b>	
			Air dryer bypass	
1010	1622 6123 00 •	1	Pipe	
1015	0346 1000 21 •	1	Clamp	
1020	0147 1247 03 •	1	Bolt	
1025	0301 2321 00 •	1	Washer	
1030	1622 6124 80 •	1	Support	
1035	0147 1963 08 •	1	Hexagon bolt	
1040	1622 6125 00 •	1	Ball valve	
1045	0571 0035 28 •	4	Nipple	
1050	0575 0125 49 •	1	Hose assembly	
1055	0574 9911 41 •	1	Hose assembly	
1060	0560 4401 34 •	1	Tee	
1065	0852 0010 34 •	1	Ball valve	
1070	1622 4739 60 •	1	Outlet	
1080	1622 6128 00 •	1	Decal	
2010	0574 9911 41 •	1	Hose assembly	

19

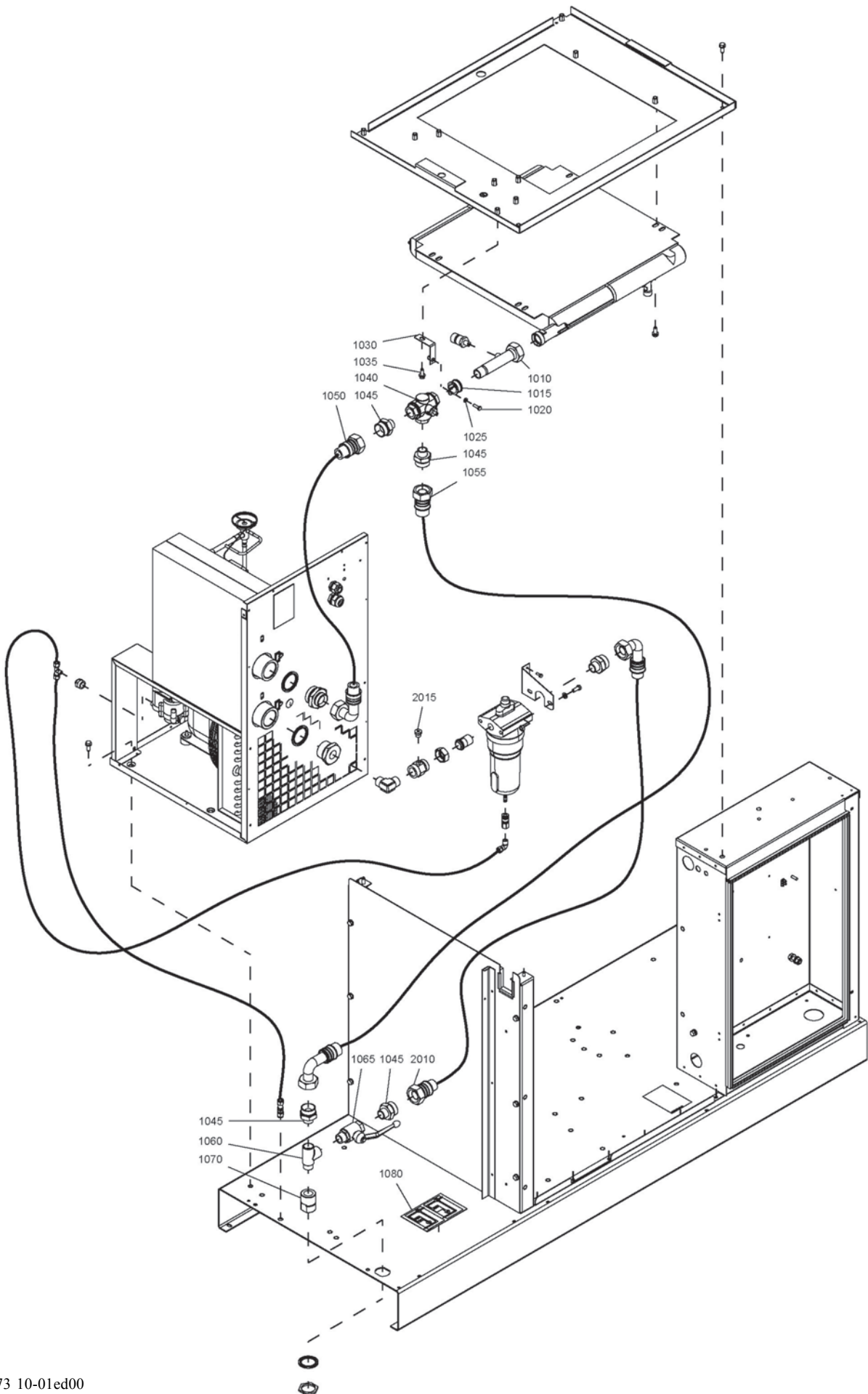

9820 4673 10-01ed00

**Standard option - Air dryer - Bypass with DDx filter**
**19**

Ref.	Part number	Qty	Name	Remarks
	<b>8092 2908 92</b>	<b>1</b>	<b>Standard option</b>	
			Air dryer bypass with DDx filter	
1010	1622 6123 00 •	1	Pipe	
1015	0346 1000 21 •	1	Clamp	
1020	0147 1247 03 •	1	Hexagon bolt	
1025	0301 2321 00 •	1	Washer	
1030	1622 6124 80 •	1	Support	
1035	0147 1963 08 •	1	Hexagon bolt	
1040	1622 6125 00 •	1	Ball valve	
1045	0571 0035 28 •	4	Nipple	
1050	0575 0125 49 •	1	Hose assembly	
1055	0574 9911 41 •	1	Hose assembly	
1060	0560 4401 34 •	1	Tee	
1065	0852 0010 34 •	1	Ball valve	
1070	1622 4739 60 •	1	Outlet	
1080	1622 6128 00 •	1	Decal	
2010	0575 0125 51 •	1	Hose assembly	
2015	0686 3718 24 •	1	Plug	

20

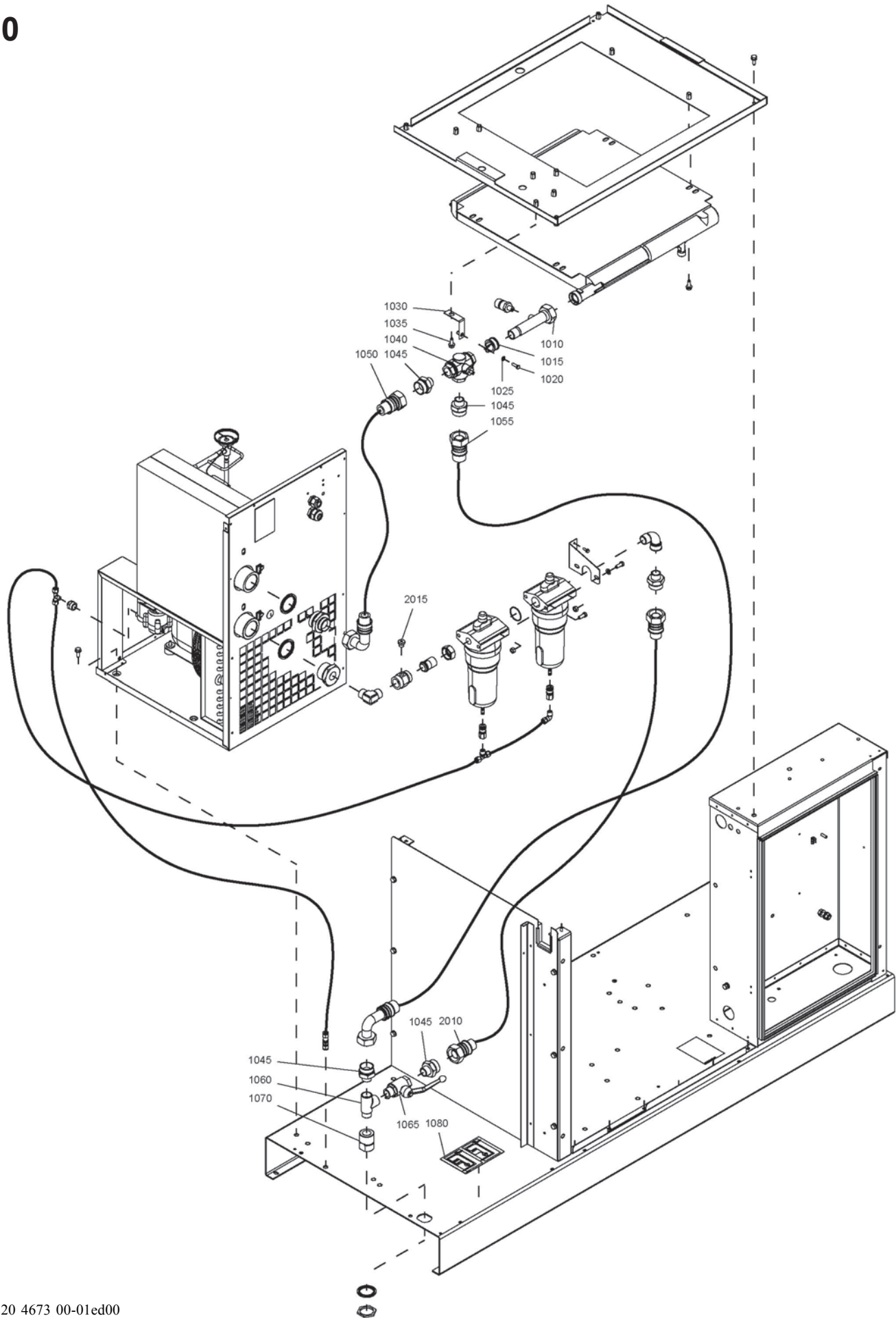

9820 4673 00-01ed00

**Standard option - Air dryer- Bypass with DDx/PDx filters**

20

Ref.	Part number	Qty	Name	Remarks
		<b>1</b>	<b>Standard option</b>	
	<b>8092 2909 00</b>		Air dryer bypass with DDx/PDx filter	
1010	1622 6123 00 •	1	Pipe	
1015	0346 1000 21 •	1	Clamp	
1020	0147 1247 03 •	1	Hexagon bolt	
1025	0301 2321 00 •	1	Washer	
1030	1622 6124 80 •	1	Support	
1035	0147 1963 08 •	1	Hexagon bolt	
1040	1622 6125 00 •	1	Ball valve	
1045	0571 0035 28 •	4	Nipple	
1050	0575 0125 49 •	1	Hose assembly	
1055	0574 9911 41 •	1	Hose assembly	
1060	0560 4401 34 •	1	Tee	
1065	0852 0010 34 •	1	Ball valve	
1070	1622 4739 60 •	1	Outlet	
1080	1622 6128 00 •	1	Decal	
2010	0575 0057 16 •	1	Hose assembly	
2015	0686 3718 24 •	1	Plug	

21

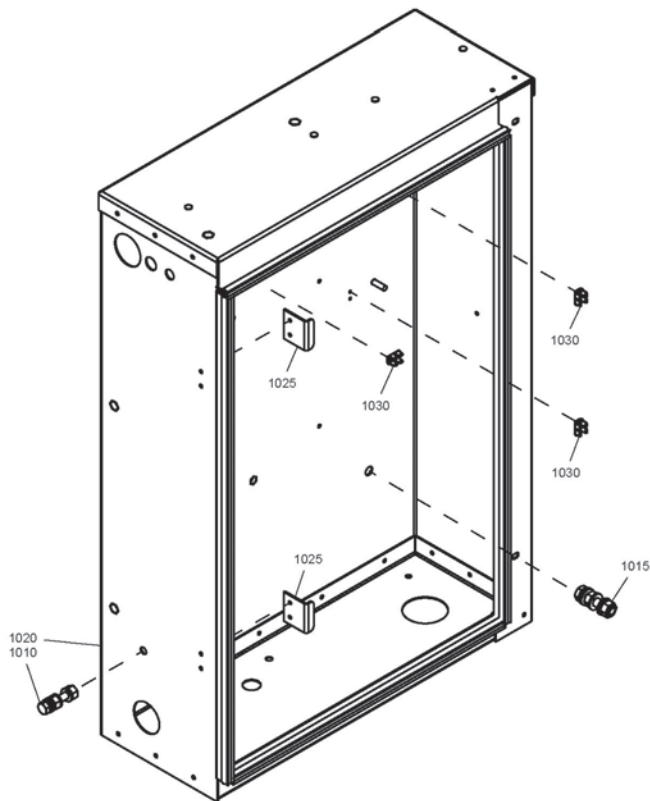
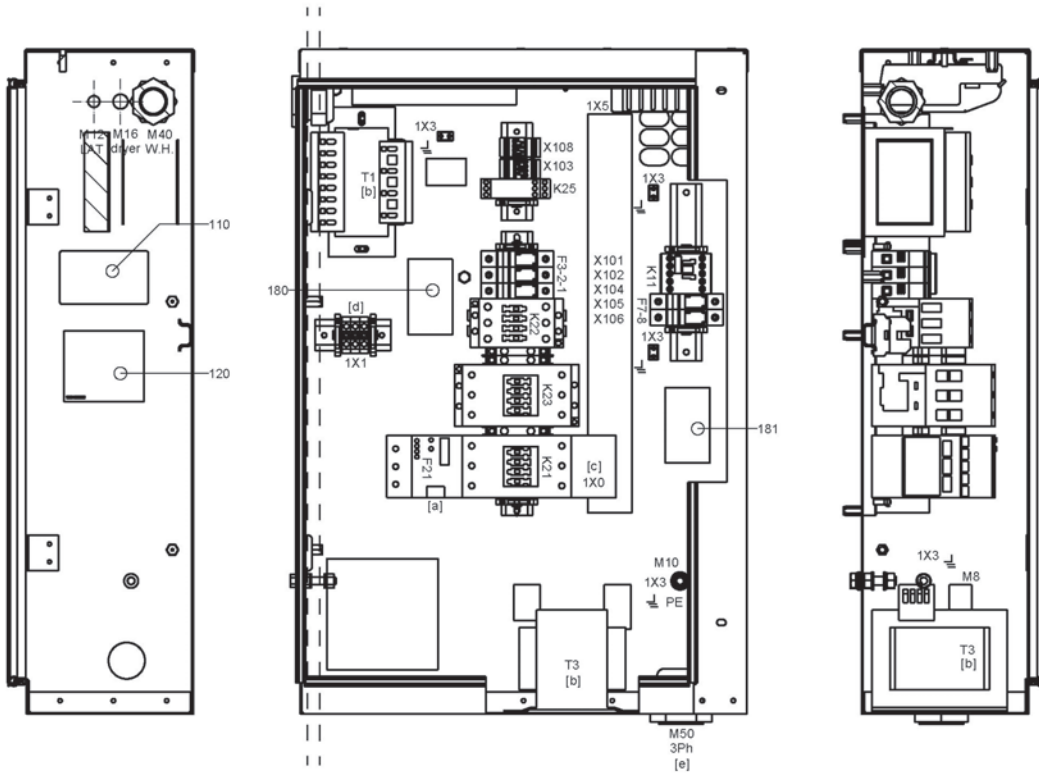

## Standard option - Air dryer - Electrical equipment

21

Ref.	Part number	Qty	Name	Remarks
	<b>1900 2601 04</b>	<b>1</b>	<b>Dryer rail IEC</b>	
	Fastoncover			
	0694 5285 12 •	2	Isolator cap	
L1-L2	0694 5285 25 •	2	Cable lug	
onK11	0694 5900 10 •	2	Fork faston	
	Fastoncover			
	1088 0003 24 •	2	Cable lug	
X114	1088 0015 05 •	1	Connector	
X114	1088 0015 36 •	4	Connector socket	
X113	1088 0031 75 •	1	Connector	
X113	1088 0037 22 •	1	Connector	
X104	1088 0037 63 •	1	Connectorcor	
1X0:N	1089 0506 03 •	1	Terminal	
1X2:N	1089 0506 60 •	1	Terminal	
F7-F8	1089 0612 01 •	2	Fuseholder	
F7-F8	1089 0612 28 •	2	Fuse	
K11	1089 9415 14 •	1	Contactora	
200mm	9139 5000 16 •	1	Mounting rail	
100	9820 3547 81 •	1	Assembly drawing	
-	1089 0506 30 •	2	End bracket	
-	1089 0577 58 •	2	End retainer	
	<b>1900 2610 51</b>	<b>1</b>	<b>Dryer rail - UL-cUL</b>	
	fastoncover			
	0694 5285 12 •	2	Isolator cap	
L1-L2	0694 5285 25 •	2	Cable lug	
onK11	0694 5900 10 •	2	Fork faston	
181	1079 9924 71 •	1	Label	
	fastoncover			
	1088 0003 24 •	2	Cable lug	
X114	1088 0015 05 •	1	Connector male	
X114	1088 0015 36 •	4	Connector socket	
X113	1088 0031 75 •	1	Connector	
X113	1088 0037 22 •	1	Connector	
X104	1088 0037 63 •	1	Connector combi	
1X2:N	1089 0506 06 •	1	Terminal	
-	1089 0577 58 •	2	End retainer	
F7-F8	1089 0612 02 •	2	Fuse holder	
F7-F8	1089 9168 62 •	2	Fuse link	
K11	1089 9415 16 •	1	Contactora	
200mm	9139 5000 16 •	1	Mounting rail	
100	9820 3547 81 •	1	Assembly drawing	
		<b>1</b>	<b>Prepared connector</b>	
	<b>1900 2601 93</b>		200-230V	
	<b>1900 2601 94</b>		400V	
X114	1088 0015 26 •	1	Connector female	
X114	1088 0015 16 •	4	Connector pin	
	<b>1900 2602 25</b>	<b>1</b>	<b>Trafo ass'y</b>	
T3	1089 9437 52 •	1	Autotransformer	
X114	1088 0015 26 •	1	Connector female	
X114	1088 0015 16 •	5	Connector pin	

22

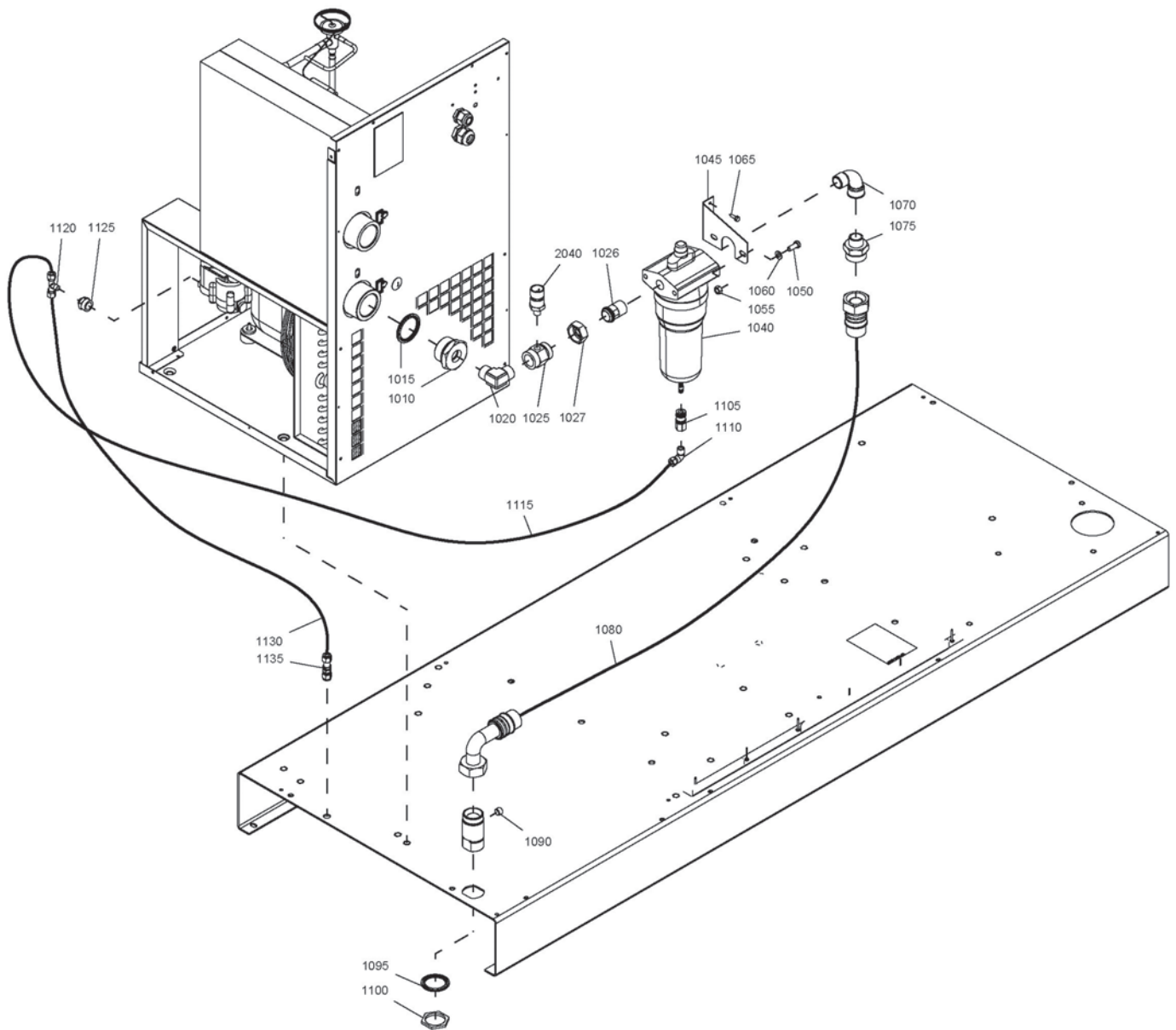



## Standard option - Full Feature - DDx filter

22

Ref.	Part number	Qty	Name	Remarks
		<b>1</b>	<b>Standard option</b>	
			DDx filter	
	<b>8092 2902 15</b>		GA 15	
	<b>8092 2902 23</b>		GA 18 7.5 bar(e)	
	<b>8092 2902 23</b>		GA 18 10 bar(e)	
	<b>8092 2902 15</b>		GA 18 13 bar(e)	
	<b>8092 2902 23</b>		GA 18 100 psig	
	<b>8092 2902 23</b>		GA 18 150 psig	
	<b>8092 2902 15</b>		GA 18 175 psig	
	<b>8092 2902 23</b>		GA 22	
1010	•	1	Bushing	
	0605 8700 27		A6X	
	0605 8701 11		A7X	
1015	•	1	Seal	
	0661 1000 60		A6X	
	0661 1000 61		A7X	
1020	0560 0200 85 •	1	Elbow	
1025	1622 6122 00 •	1	Nipple	
1026	1622 0697 00 •	1	Coupling	
1027	1622 0698 00 •	1	Nut	
1040	1624 1090 04 •	1	DDx 55	
1045	1622 6120 00 •	1	Support	
1050	0215 0003 73 •	2	Screw	
1055	0266 2110 00 •	2	Nut	
1060	0301 2335 00 •	2	Washer	
1065	1079 2263 02 •	2	Screw	
1070	0562 3106 03 •	1	Bend	
1075	0571 0035 28 •	1	Nipple	
1080	0575 0125 49 •	1	Hose assembly	
1090	0686 6128 00 •	1	Plug	
1095	0661 1000 62 •	1	Seal	
1100	0697 9809 06 •	1	Lock nut	
1105	1617 7082 02 •	1	Quick coupling	
1110	0581 1200 23 •	1	Elbow coupling	
1115	0070 6002 05 •	AR	Plastic tube	
1120	0581 2000 30 •	1	Coupling	
1125	0607 1151 06 •	1	Socket	
1130	0070 6002 05 •	AR	Plastic tube	
1135	0581 0000 55 •	1	Coupling	
2040	1089 0575 54 •	1	Pressure transducer	

23

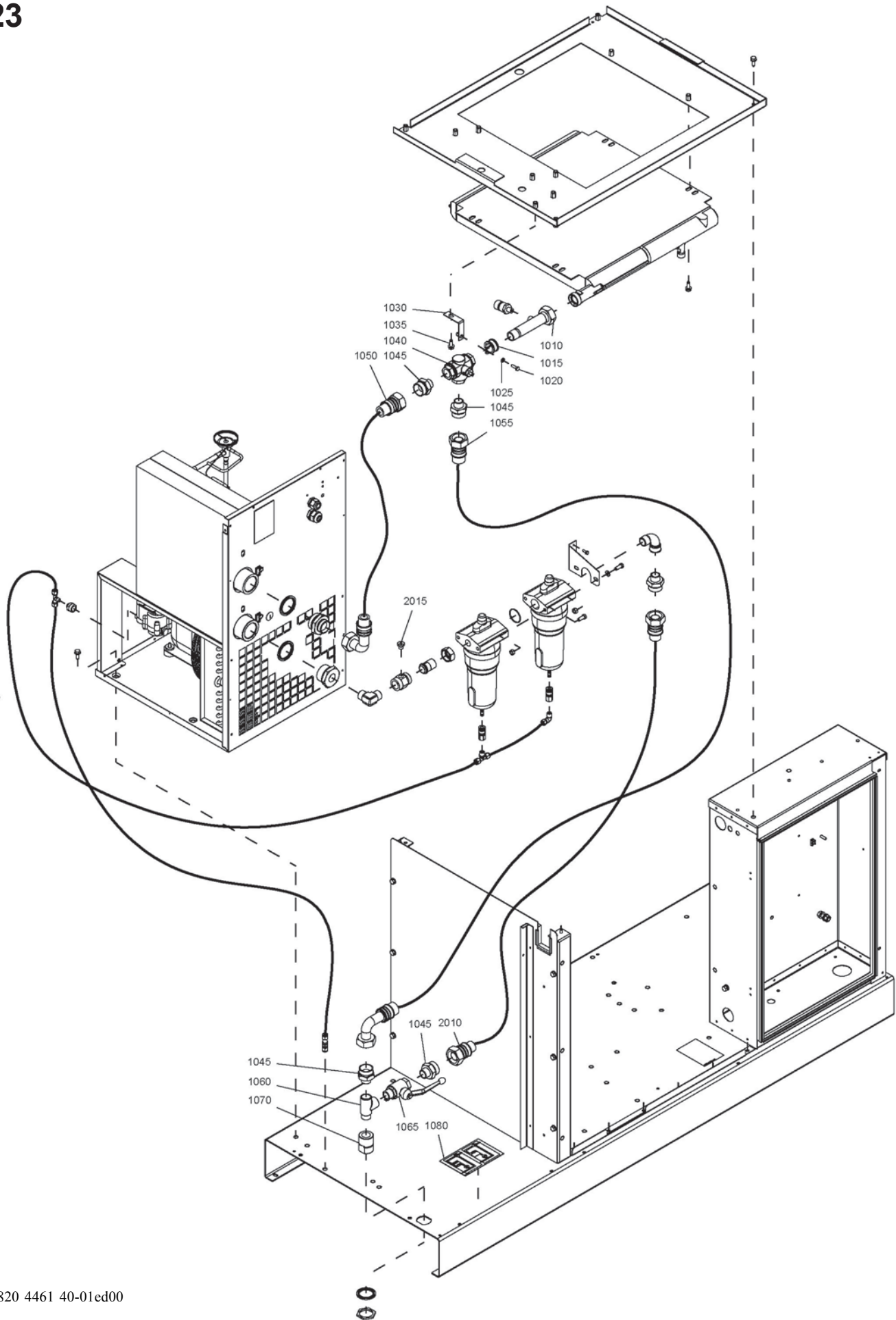

9820 4461 40-01ed00

## Standard option - Full Feature - DDx/PDx filter

23

Ref.	Part number	Qty	Name	Remarks
		<b>1</b>	<b>Standard option</b>	
			DDx/PDx filters	
	<b>8092 2904 91</b>		GA 15	
	<b>8092 2902 49</b>		GA 18 7.5 bar(e)	
	<b>8092 2902 49</b>		GA 18 10 bar(e)	
	<b>8092 2904 91</b>		GA 18 13 bar(e)	
	<b>8092 2902 49</b>		GA 18 100 psig	
	<b>8092 2902 49</b>		GA 18 150 psig	
	<b>8092 2904 91</b>		GA 18 175 psig	
	<b>8092 2902 49</b>		GA 22	
1010	•	1	Bushing	
	0605 8700 27		A6X	
	0605 8701 11		A7X	
1015	•	1	Seal	
	0661 1000 60		A6X	
	0661 1000 61		A7X	
1020	0560 0200 85 •	1	Elbow	
1025	1622 6122 00 •	1	Nipple	
1026	1622 0697 00 •	1	Coupling	
1027	1622 0698 00 •	1	Nut	
1040	1624 1090 04 •	1	DDx 55	
1045	1624 1090 03 •	1	PDx 55	
1050	0663 2101 97 •	1	O-ring	
1055	0215 0003 73 •	2	Screw	
1060	0266 2110 00 •	2	Nut	
1065	1622 6120 00 •	1	Support	
1070	0215 0003 73 •	2	Screw	
1075	0266 2110 00 •	2	Nut	
1080	0301 2335 00 •	2	Washer	
1085	1079 2263 02 •	2	Screw	
1090	0562 3106 03 •	1	Bend	
1095	0571 0035 28 •	1	Nipple	
1100	0575 0125 50 •	1	Hose assembly	
1105	1622 4739 50 •	1	Outlet	
1110	0686 6128 00 •	1	Plug	
1115	0661 1000 62 •	1	Seal	
1120	0697 9809 06 •	1	Lock nut	
1125	1617 7082 02 •	2	Quick coupling	
1130	0581 1200 23 •	1	Elbow coupling	
1135	0070 6002 05 •	AR	Plastic tube	
1140	0581 2000 28 •	1	Tee	
1145	0070 6002 05 •	AR	Plastic tube	
1150	0581 2000 30 •	1	Coupling	
1155	0607 1151 06 •	1	Socket	
1160	0070 6002 05 •	AR	Plastic tube	
1165	0581 0000 55 •	1	Pipe coupling	
2040	1089 0575 54 •	1	Pressure transducer	

24

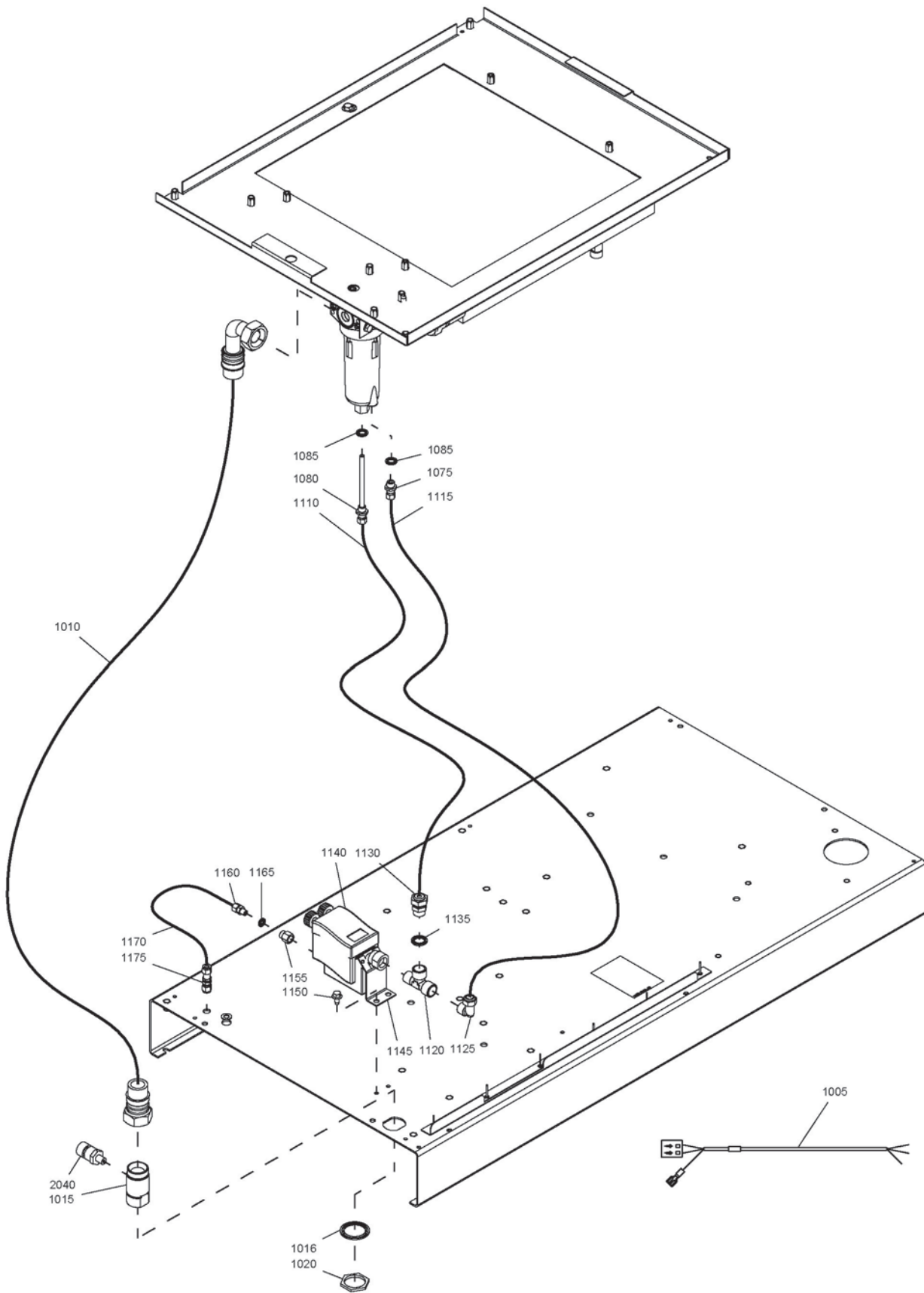

## Standard option - Electronic Water Drain - Pack

24

Ref.	Part number	Qty	Name	Remarks
	<b>8092 2903 06</b>	<b>1</b>	<b>Standard option</b>	
			Electronic Water Drain - Pack	
1005	1622 0629 12 •	1	Wiring	
1010	0574 9911 41 •	1	Hose assembly	
1015	1622 4739 50 •	1	Outlet	
1016	0661 1000 62 •	1	Seal	
1020	0697 9809 06 •	1	Lock nut	
1075	0581 0000 35 •	1	Coupling	
1080	1613 8084 00 •	1	Pipe coupling	
1085	0661 1000 38 •	2	Seal washer	
1110	0070 6002 05 •	AR	Plastic tube	
1115	0070 6002 06 •	AR	Plastic tube	
1120	1503 2566 13 •	1	Tee	
1125	0581 1200 29 •	1	Elbow coupling	
1130	0581 0000 73 •	1	Coupling	
1135	0661 1000 39 •	1	Washer	
1140	1613 8913 02 •	1	EWD 50	
1145	1622 0833 00 •	1	Support	
1150	0226 0301 00 •	2	Screw	
1155	0607 1151 05 •	1	Reducing socket	
1160	0581 0000 38 •	1	Pipe coupling	
1165	0661 1000 42 •	1	Seal washer	
1170	0070 6002 05 •	AR	Plastic tube	
1175	0581 0000 55 •	1	Coupling	
2040	1089 0575 54 •	1	Press.Transducer	

25

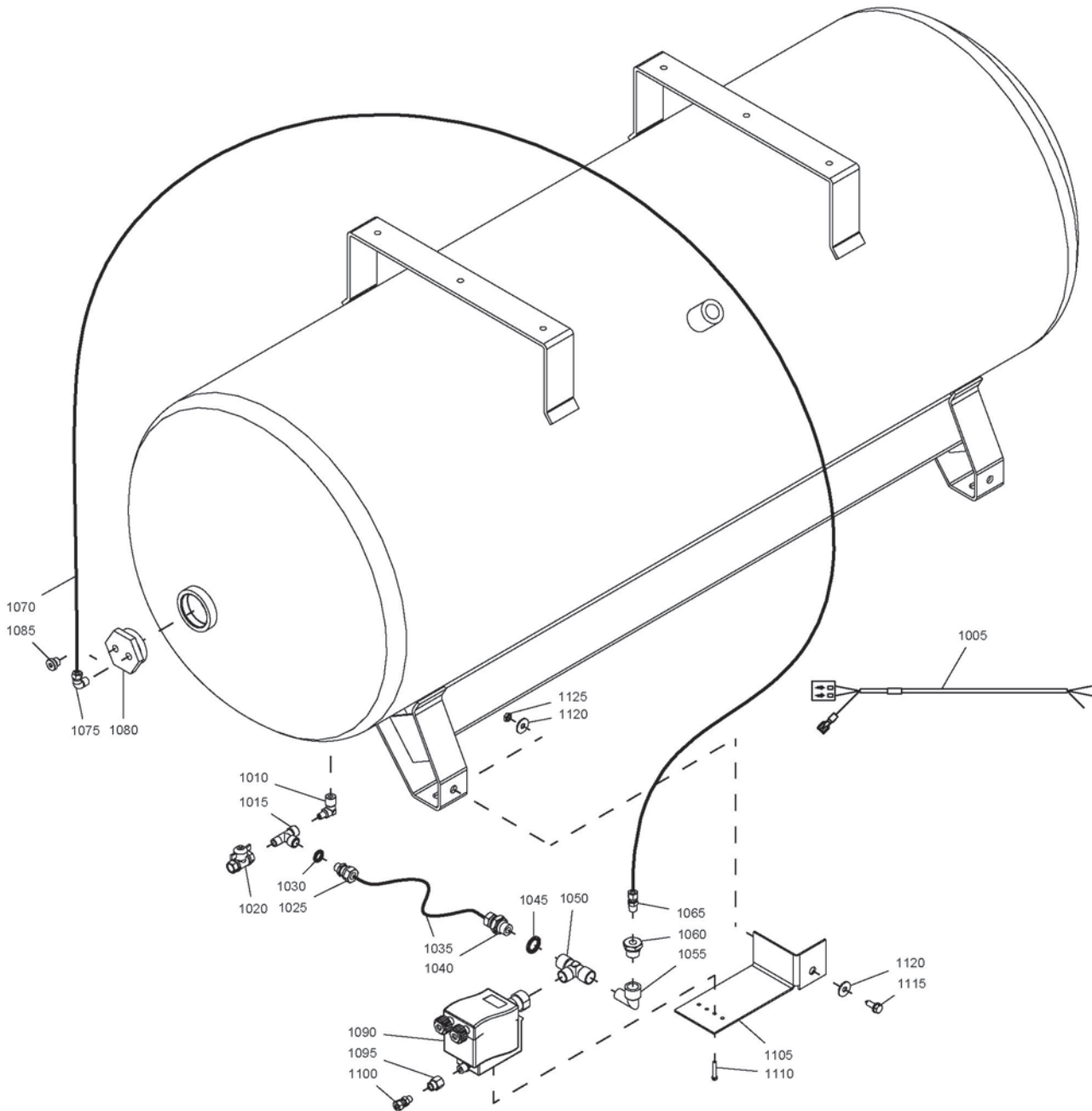

## Standard option - Electronic Water Drain - No US Air receiver

25

Ref.	Part number	Qty	Name	Remarks
	<b>8092 2902 80</b>	<b>1</b>	<b>Standard option</b>	
			Electronic Water Drain - No US Air receiver	
1005	1622 0629 12 •	1	Wiring	
1010	1503 2565 41 •		Elbow	
1015	1503 2566 11 •	1	Tee	
1020	0852 0010 36 •	1	Ball valve	
1025	0581 0000 45 •	1	Coupling	
1030	0661 1000 38 •	1	Seal washer	
1035	0070 6002 06 •	AR	Plastic tube	
1040	0581 0000 53 •	1	Coupling	
1045	0661 1000 39 •	1	Washer	
1050	1503 2566 23 •	1	Tee	
1055	1503 2565 04 •	1	Elbow	
1060	0605 8700 90 •	1	Bushing	
1065	0581 0000 78 •	1	Pipe coupling	
1070	0070 6002 05 •	AR	Plastic tube	
1075	0581 1200 23 •	1	Elbow coupling	
1080	1622 1231 00 •	1	Plug	
1085	0686 3718 24 •	1	Plug	
1090	1613 8913 02 •	1	EWD 50	
1095	0607 1151 05 •	1	Socket	
1100	0581 0000 59 •	1	Coupling	
1105	1622 1232 00 •	1	Support	
1110	0160 6066 00 •	2	Bolt	
1115	0147 1964 29 •	1	Hexagon bolt	
1120	0300 8019 00 •	2	Washer	
1125	0261 2110 00 •	1	Nut	

26

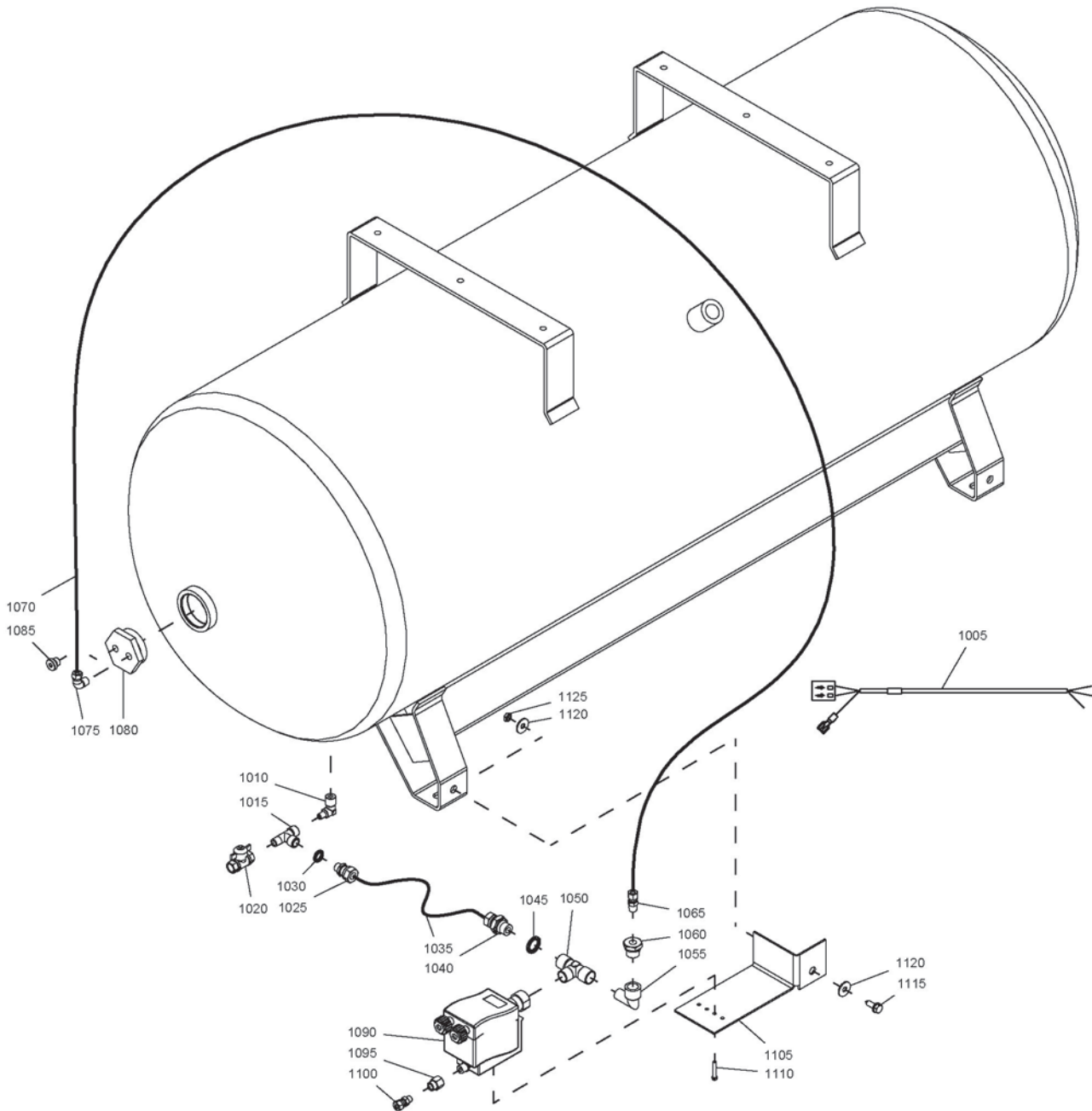



## Standard option - Electronic Water Drain - US Air receiver

26

Ref.	Part number	Qty	Name	Remarks
	<b>8092 2902 98</b>	<b>1</b>	<b>Standard option</b>	
			Electronic Water Drain - US Air receiver	
1005	1622 0629 12 •	1	Wiring	
1010	0560 4400 51 •	1	Elbow	
1015	1503 2566 11 •	1	Tee	
1020	0852 2000 04 •	1	Ball Valve	
1025	0581 1200 27 •	1	Coupling	
1030	0070 6002 06 •	2	Plastic Tube	
1035	0581 0000 53 •	1	Coupling	
1040	0661 1000 39 •	1	Seal Washer	
1045	1503 2566 23 •	1	Tee	
1050	1503 2565 04 •	1	Elbow	
1055	0605 8700 90 •	1	Bushing	
1060	0581 0000 78 •	1	Coupling	
1065	0070 6002 05 •	AR	Plastic Tube	
1070	0581 1200 23 •	1	Coupling	
1075	0605 8820 05 •	1	Bushing	
1080	0661 1000 43 •	1	Seal washer	
1085	1622 1227 01 •	1	Plug	
1090	1613 8913 02 •	1	EWD 50	
1095	0607 1151 05 •	1	Socket	
1100	0581 1200 26 •	1	Coupling	
1105	1622 1232 01 •	1	Support	
1110	0160 6066 00 •	2	Bolt	
1115	0147 1964 29 •	2	Screw	
1120	0300 8019 00 •	2	Washer	
1125	0261 2110 00 •	2	Nut	

27

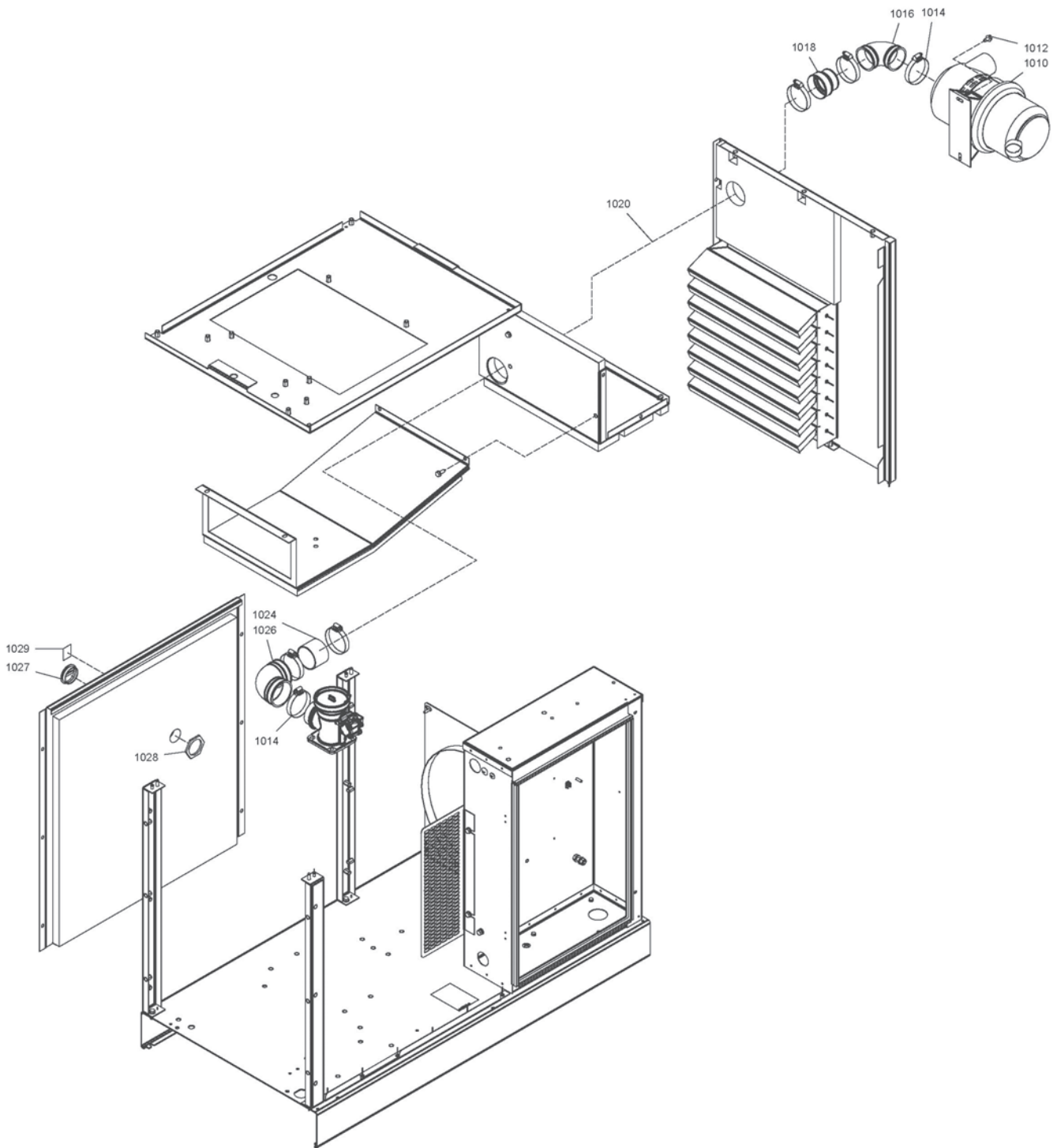

## Standard option - Heavy duty filter

27

Ref.	Part number	Qty	Name	Remarks
	<b>8092 2905 20</b>	<b>1</b>	<b>Standard option</b>	
			Heavy duty filter	
<b>1010</b>	<b>1622 1331 80 •</b>	<b>1</b>	<b>Air filter assembly</b>	
	1622 1331 00 ••	1	Filter element	
	1615 6958 00 ••	1	Support	
1012	0226 0301 00 •	2	Tapping screw	
1014	0347 6114 00 •	6	Hose clip	
1016	1622 0174 00 •	1	Elbow	
1018	1622 0173 00 •	1	Adapter	
1020	1622 6138 00 •	1	Hose	
1024	1622 4780 00 •	1	Tube	
1026	1622 4741 00 •	1	Air inlet	
1028	0697 9810 30 •	1	Plug	
1029	0697 9809 05 •	2	Lock nut	

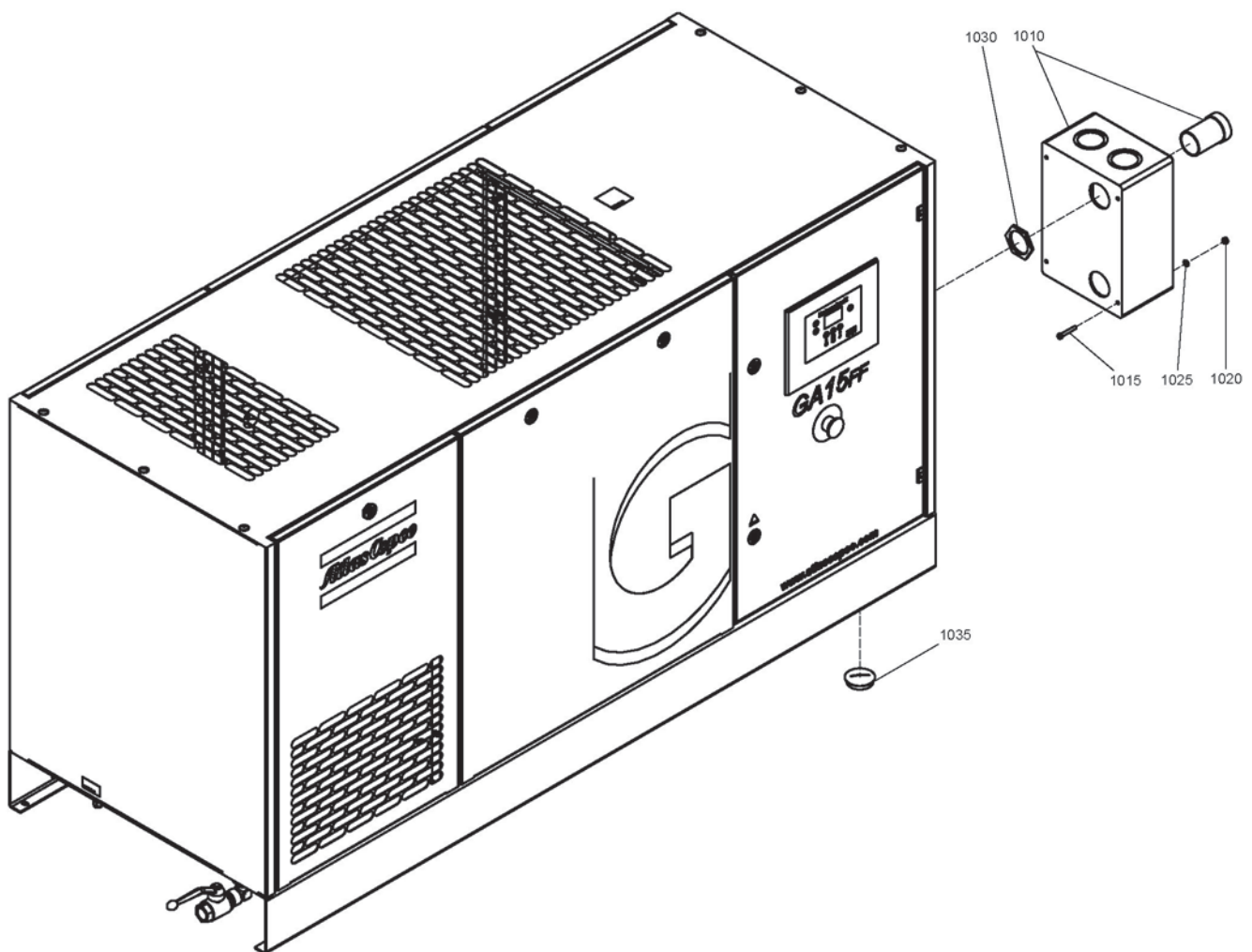

## Standard option - Main switch

28

Ref.	Part number	Qty	Name	Remarks
		<b>1</b>	<b>Standard option</b>	
			Main switch	
	<b>8092 2904 05</b>		GA 15	
	<b>8092 2904 05</b>		GA 18 Except	
	<b>8092 2904 13</b>		GA 18 200V/50-60Hz	
	<b>8092 2904 13</b>		GA 18 230V/60Hz	
	<b>8092 2904 13</b>		GA 18 460V/50-60Hz	
	<b>8092 2904 05</b>		GA 22 Except	
	<b>8092 2904 13</b>		GA 22 230V/50-60Hz	
1010	1622 1778 03 •	1	Main switch ass'y	
1015	0160 6089 00 •	4	Screw	
1020	0266 2108 00 •	4	Nut	
1025	0301 2321 00 •	4	Washer	
1030	0697 9809 05 •	2	Lock nut	
1035	0697 9810 23 •	1	Plug	

29

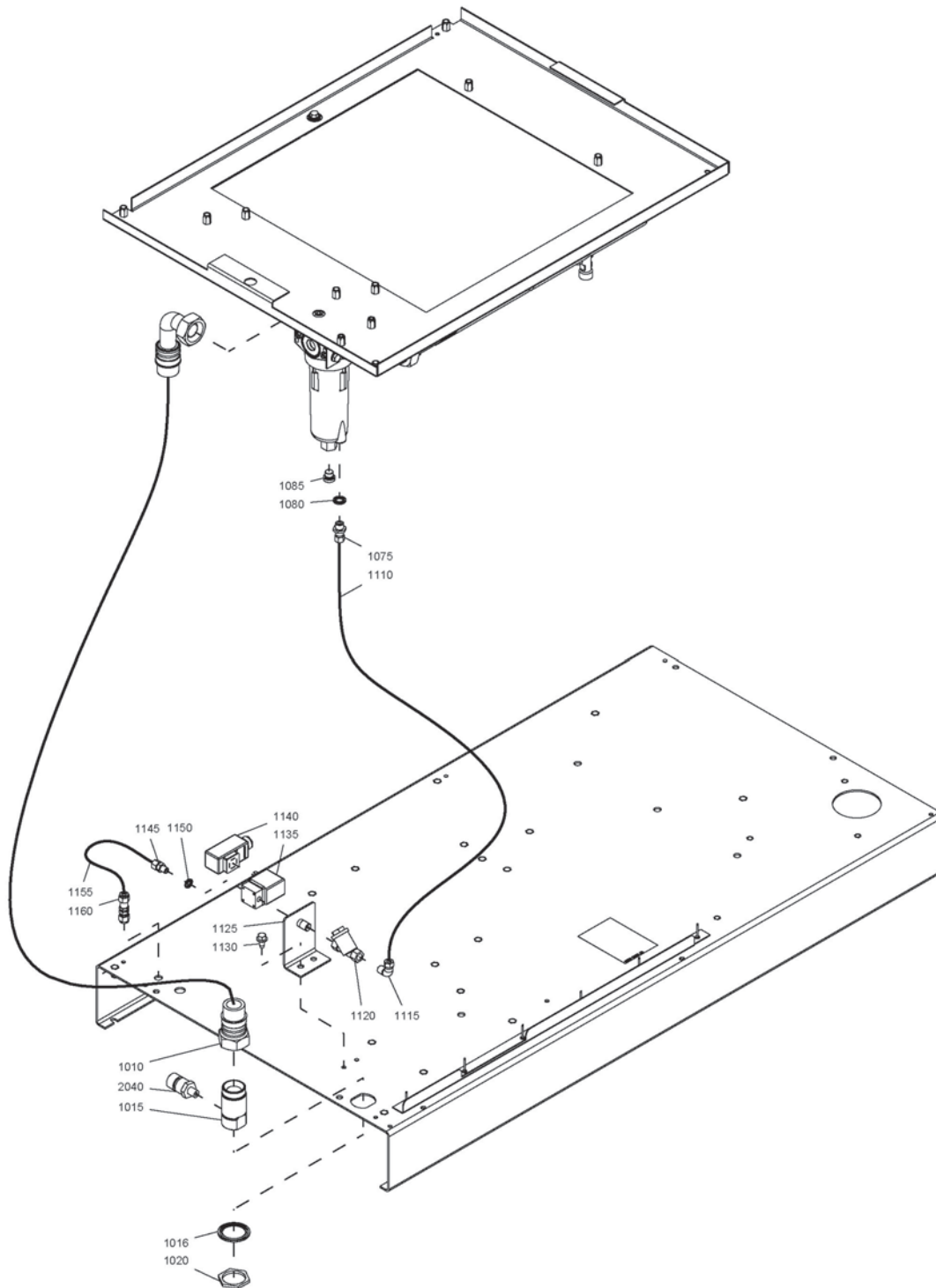

## Standard option - Timer drain - Pack

29

Ref.	Part number	Qty	Name	Remarks
	<b>8092 2903 14</b>	<b>1</b>	<b>Standard option</b>	
			Timer drain - Pack	
1010	0574 9911 41 •	1	Hose assembly	
1015	1622 4739 50 •	1	Outlet	
1016	0661 1000 62 •	1	Seal	
1020	0697 9809 06 •	1	Lock nut	
1075	0581 0000 35 •	1	Coupling	
1080	0661 1000 38 •	1	Seal washer	
1085	0686 3718 24 •	2	Plug	
1110	0070 6002 05 •	AR	Tube	
1115	0581 1200 23 •	1	Coupling	
1120	2235 2607 01 •	1	Filter	
1125	1622 6119 00 •	1	Support	
1130	0226 0301 00 •	2	Tapping screw	
1135	1089 0640 21 •	1	Solenoid valve	
1140	1089 9259 20 •	1	Timer	
1145	0581 0000 38 •	1	Pipe coupling	
1150	0661 1000 42 •	1	Seal washer	
1155	0070 6002 05 •	AR	Tube	
1160	0581 0000 55 •	1	Pipe coupling	
2040	1089 0575 54 •	1	Transducer	

30

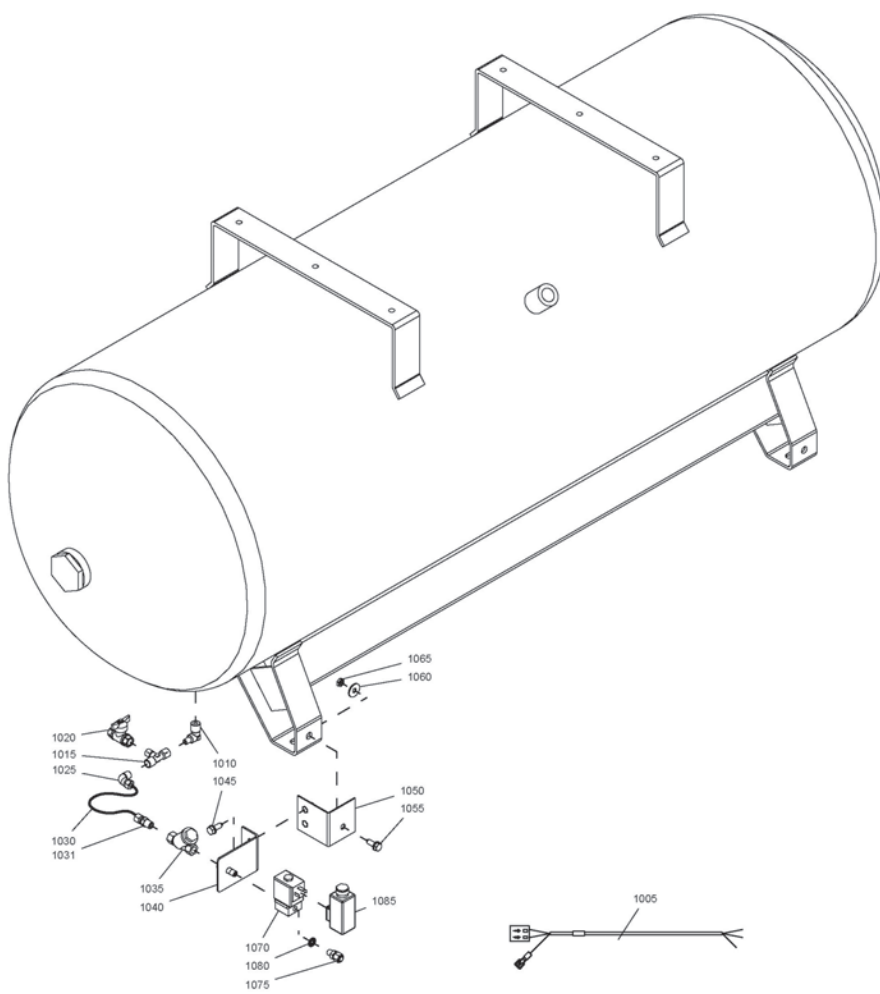



## Standard option - Timer drain - No US Air receiver

30

Ref.	Part number	Qty	Name	Remarks
		<b>1</b>	<b>Standard option</b>	
			Timer drain - No US Air receiver	
	<b>8092 2903 55</b>		Full Feature ASME	
	<b>8092 2903 30</b>		Full Feature CE	
	<b>8092 2903 48</b>		Pack ASME	
	<b>8092 2903 22</b>		Pack CE	
1005	1622 0629 12 •	1	Wiring	
1010	1503 2565 41 •	1	Elbow	
1015	1503 2566 21 •	1	Tee	
1020	0852 0010 36 •	1	Ball valve	
1025	0581 1200 23 •	1	Coupling	
1030	0070 6002 05 •	AR	Plastic tube	
1031	0581 0000 78 •	1	Coupling	
1035	2235 2607 01 •	1	Filter	
1040	1622 6119 00 •	1	Support	
1045	0147 1964 29 •	1	Hexagon bolt	
1050	1622 6121 00 •	1	Support	
1055	0147 1964 29 •	1	Hexagon bolt	
1060	0300 8019 00 •	1	Washer	
1065	0261 2110 00 •	1	Nut	
1070	1089 0640 21 •	1	Solenoid valve	
1075	0581 0000 38 •	1	Coupling	
1080	0661 1000 42 •	1	Seal washer	
1085	1089 9259 20 •	1	Timer	

31

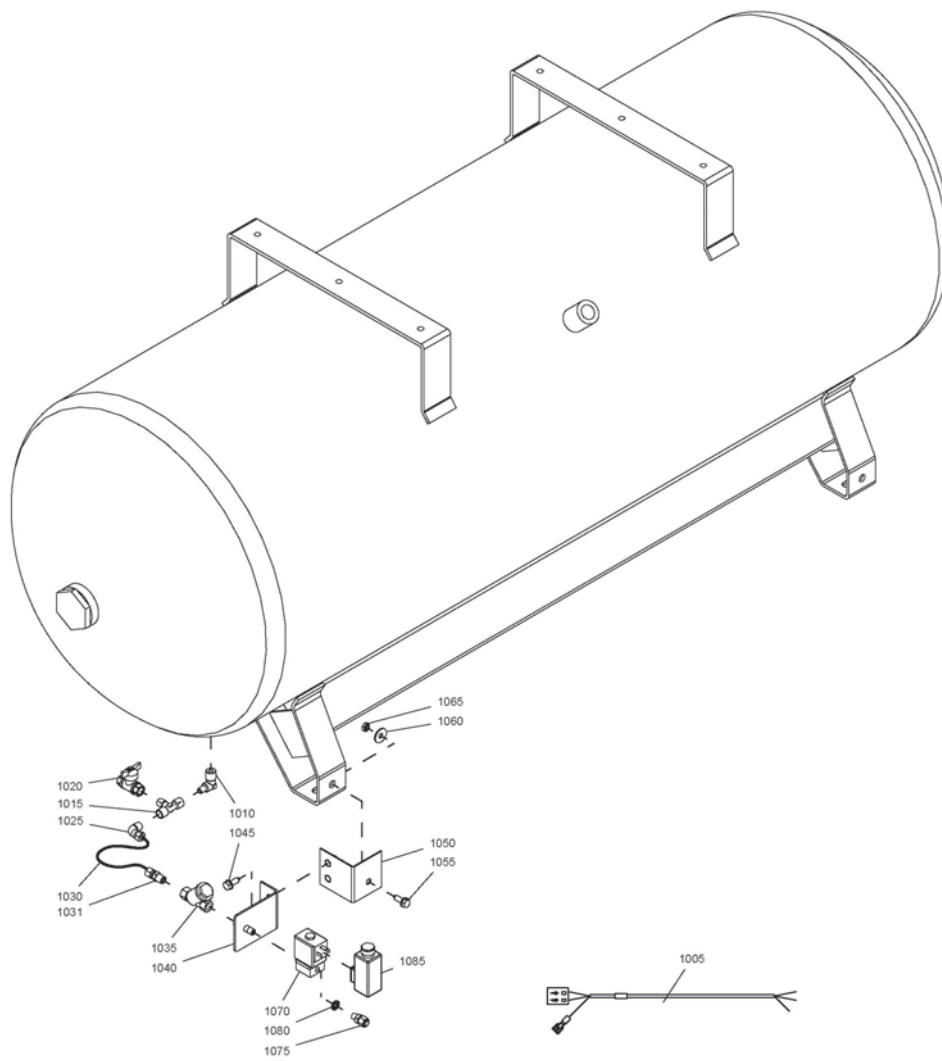

**Standard option - Timer drain - US Air receiver****31**

Ref.	Part number	Qty	Name	Remarks
	<b>8092 2903 63</b>	<b>1</b>	<b>Standard option</b>	
			Timer drain - US Air receiver	
1015	1503 2566 11 •	1	Tee	
1020	0852 0010 45 •	1	Ball valve	
1025	0581 0000 78 •	2	Pipe coupling	
1030	0070 6002 05 •	AR	Tube	
1035	2235 2607 01 •	1	Filter	
1040	1622 6119 00 •	1	Support	
1045	0147 1964 29 •	2	Screw	
1050	0300 8019 00 •	2	Washer	
1055	0261 2110 00 •	2	Nut	
1060	1089 0640 21 •	1	Valve	
1065	0581 0000 38 •	1	Pipe coupling	
1070	0661 1000 42 •	1	Seal washer	
1075	1089 9259 20 •	1	Timer	

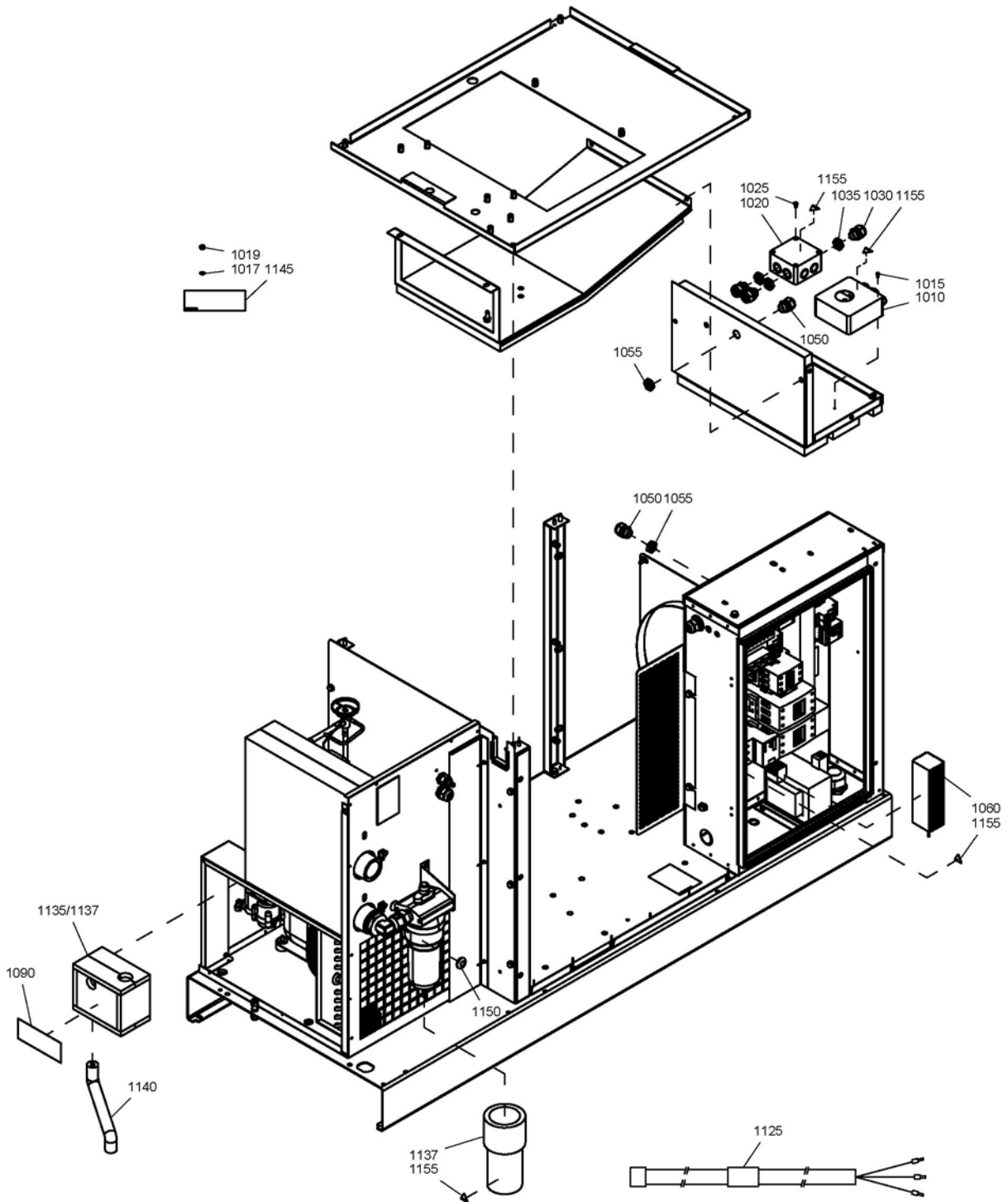

## Standard option - Freeze protection

32

Ref.	Part number	Qty	Name	Remarks
1010		1	Thermostat	
	1089 0555 40		IEC	
	1089 9582 02		UL-cUL	
1015			Screw	
	0226 3343 59	4	IEC	
	0160 6084 00	2	UL-cUL	
1017		2	Washer	
	0333 3120 00		UL-cUL	
1019		2	Nut	
	0266 2108 00		UL-cUL	
1020	1089 0555 03	1	Connection box	
1025	0226 3281 00	2	Screw	
1030	0698 5140 72	3	Cable gland	
1035	0697 9809 21	3	Lock nut	
1050	0698 5140 72	2	Cable gland	
1055	0697 9809 21	2	Lock nut	
1060	1089 0504 33	1	Heater	
1090	1079 9924 46	1	Warning label	
1125		1	Tracing	
	1613 9763 10		EWD dryer IEC	
	1613 9763 09		EWD dryer UL-cUL	
	1613 9763 12		WSD (Pack) IEC	
	1613 9763 11		WSD (Pack) UL-cUL	
1130	1079 0900 02	7	Heat insulation tape	
1135	1079 0900 15	AR	Tape	
1137		1	Insulation	
	1617 1504 80		Pack	
	1622 6133 00		Full Feature	
1140	0395 1010 29	AR	Insulation tube	
1145	1079 9924 46	1	Warning label	
1150	0698 0153 00	1	Grommet	
1155	1088 1001 01	3	Warning mark	











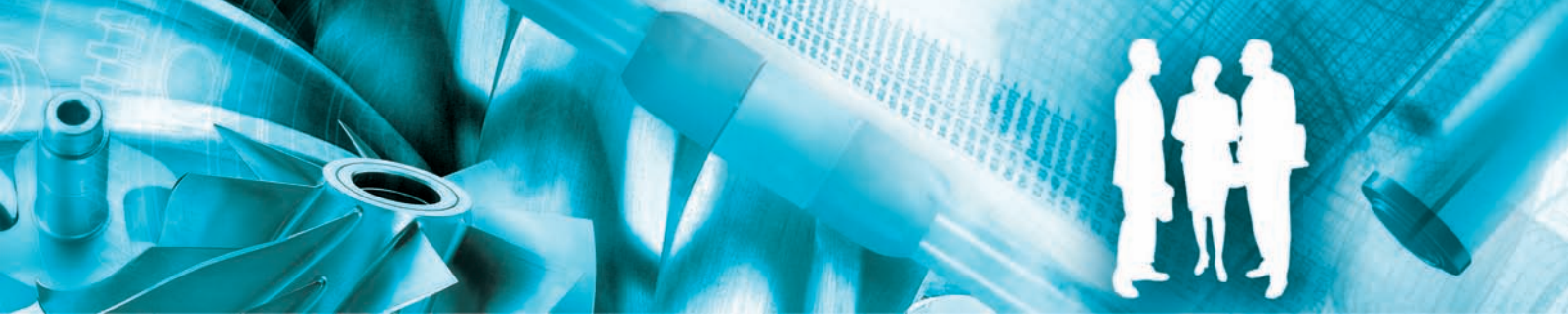

In order to be First in Mind-First in Choice<sup>®</sup> for all your quality compressed air needs, Atlas Copco delivers the products and services that help to increase your business' efficiency and profitability.

Atlas Copco's pursuit of innovation never ceases, driven by our need for reliability and efficiency. Always working with you, we are committed to providing you the customized quality air solution that is the driving force behind your business.



# Atlas Copco

## Oil-free rotary tooth compressors



**ZR 30, ZR 37, ZR 45, ZT 30, ZT 37, ZT 45**

Parts list

*Atlas Copco*

# Atlas Copco

## Oil-free rotary tooth compressors

ZR 30, ZR 37, ZR 45, ZT 30, ZT 37, ZT 45

From following serial No. onwards: API 790 950

### Parts list

- Copyright, Atlas Copco Airpower n.v., Antwerp, Belgium.  
Any unauthorized use or copying of the contents or any part thereof is prohibited.  
This applies in particular to trademarks, model denominations, part numbers and drawings.
- **Use only authorized parts.** Any damage or malfunction caused by the use of unauthorized parts is not covered by Warranty or Product Liability.

2015 - 03

**No. 2930 7121 62**  
Replaces No. 2930 7121 61

[www.atlascopco.com](http://www.atlascopco.com)



## Table of contents

1	Service kits.....	17
2	Drive arrangement.....	21
3	Mounting on frame, motor and air inlet.....	25
4	Air system - Inlet throttle valve .....	29
5	Air system - Air flow - Common - ZR .....	31
6	Air system - Air flow - Common - ZT 30, ZT 37, ZT 45 7.5bar(e) .....	35
7	Air system - Air Flow - Venturi parts - ZT 45 8.6bar(e).....	37
8	Air system - Pulsation damper .....	39
9	Air system - Air outlet - Pack - ZR.....	41
10	Air system - Air outlet - Pack - ZT.....	43
11	Air system - Air outlet - Pack - HAV version - ZR .....	45
12	Air system - Air outlet - Pack - HAV version - ZT.....	47
13	Air system - Air outlet - Full Feature - ZR 30, ZR 37, ZR 45 - ID 100, ID136.....	49
14	Air system - Air outlet - Full Feature - ZT 30-ID 100, ZT 37-ID 100, ZT 45-ID 136 ..	51
15	ir system - Air outlet - Full Feature - ZR 30-IMD 50, ZR 37-IMD 50.....	53
16	Air system - Air outlet - Full Feature - ZT 30-IMD 50, ZT 37-IMD 50 .....	55
17	Air system - Air outlet - Full Feature - ZR 45-IMD 100 .....	57
18	ir system - Air outlet - Full Feature - ZT 45-IMD 100.....	59
19	Air system - Air outlet - Full Feature ID 100, ID 136.....	61
20	ir system - Air outlet - Full Feature - Air dryer - IMD 50 - Mountings on vessel.....	67
21	Air system - Air outlet - Full Feature - Air dryer - IMD 100 - Mountings on vessel....	69
22	Air system - Air outlet - Full Feature - Air dryer - IMD 50 - Pressure vessel.....	71
23	Air system - Air outlet - Full Feature - Air dryer - IMD 100 - Pressure vessel.....	73
24	Air system - Air outlet - Full Feature - Air dryer - IMD 50 - Motor and drive .....	75
25	Air system - Air outlet - Full Feature - Air dryer - IMD 100 - Motor and drive .....	77
26	Air system - Air outlet - Full Feature - Air dryer - IMD 50 - Cooler and drain.....	79
27	Air system - Air outlet - Full Feature - Air dryer - IMD 100 - Cooler and drain.....	81

28	Air system - Air outlet - Full Feature - Air dryer - IMD 50, IMD 100 - Pressure transducer set .....	83
29	Cooling system - Coolers - Mountings - ZR .....	85
30	Cooling system - Coolers - ZR .....	87
31	Cooling system - Coolers - Mountings - ZT .....	89
32	Cooling system - Coolers - Fan - Common - ZT .....	91
33	Coolers - Fan - ZR-IMD, ZT-IMD .....	99
34	Oil system - ZR .....	103
35	Oil system - ZT .....	105
36	Regulating system - ZR .....	107
37	Regulating system - ZT .....	109
38	Drain system - Common - ZR .....	111
39	Drain system - Common - ZT .....	115
40	Drain system - ZR - Full Feature ID .....	119
41	Drain system - ZT - Full Feature ID .....	121
42	Drain system - ZR - Full Feature IMD .....	123
43	Drain system - ZT - Full Feature IMD .....	127
44	Cubicle - IEC .....	131
45	Cubicle - UL - cUL .....	143
46	Base module power supply JAPAN .....	153
47	Cubicle - Plug-in's .....	157
48	Bodywork - Common - ZR .....	161
49	Bodywork - Common - ZT .....	163
50	Bodywork - Pack - ZR .....	165
51	Bodywork - Pack - ZT .....	169
52	Bodywork - Full Feature - ZR-ID .....	173
53	Bodywork - Full Feature - ZT-ID .....	177
54	Bodywork - Full Feature - ZR-IMD .....	181

## Table of contents

55	Bodywork - Full Feature - ZT-IMD .....	185
56	Standard option - Anchor pads.....	189
57	Standard option - ANSI Flange.....	191
58	Standard option - Rain Protection .....	193
59	Standard option - Air dryer by-pass - ZR - ID .....	195
60	Standard option - Air dryer by-pass - ZT - ID .....	197
61	Standard option - Air dryer by-pass - ZR - IMD .....	199
62	Standard option - Air dryer by-pass - ZT - IMD .....	201
63	Standard option - Main switch - Internal.....	203
64	Standard option - Main switch - External.....	205
65	Standard option - Anti-condensation heaters and Thermistors .....	207
66	Standard option - Flanged inlet.....	209
67	Standard option - Graphic Plus display .....	211
68	Standard option - Alarm horn .....	213
69	Standard option - AIRcontact .....	215
70	Standard option - Water shut-off valve - ZR.....	217
71	Standard option - PDP sensor.....	219





## 1

## Service kits

Ref.	Part number	Qty	Name	Remarks
		<b>1</b>	<b>Oil</b>	
	<b>2908 8503 00</b>		ROTO-Z 5 Litres	
	<b>2908 8501 01</b>		ROTO-Z 20 Litres	
	<b>2908 8500 00</b>		ROTO-Z 209 Litres	
		<b>1</b>	<b>Air/oil filter kit</b>	
	0661 1000 62 •	1	Sealing washer	
	1614 8747 0 •	1	Oil filter element	
	1613 7407 00 •	1	Air filter element	
	0661 1000 3 •	1	Seal washer	
	9820 5631 0 •	1	Instruction	
		<b>1</b>	<b>Inlet valve service kit</b>	
	1613 4036 0 •	1	Membrane	
	1621 1005 00 •	1	Diaphragm	
	0663 2108 16 •	1	O-ring	
	1614 6819 •	1	Muffler	
	0661 1000 •	1	Seal washer	
	9820 5478 •	1	Instruction	
		<b>1</b>	<b>Inlet valve overhaul kit</b>	
	0663 2104 26 •	1	O-ring	
	0335 3114 0 •	1	Retaining ring	
	0500 4510 01 •	1	Bushing	
	0500 4510 •	1	Bearing	
	0661 1000 •	4	Seal washer	
	1613 5721 0 •	1	Spring	
	1622 1583 0 •	1	Valve (inlet)	
	0661 1000 4 •	1	Seal washer	
	9820 5639 0 •	1	Instruction	
		<b>1</b>	<b>Check valve kit</b>	
	0663 2111 •	2	O-ring	
	0663 2107 7 •	2	O-ring	
	1621 3014 0 •	1	Spring	
	1614 7368 •	1	Check valve	
	9820 5482 0 •	1	Instruction	
		<b>1</b>	<b>Breather kit</b>	
	1624 1633 0 •	1	Filter element	
	1624 1633 0 •	1	Filter element	
	0663 2107 8 •	1	O-ring	
	0663 210 •	2	O-ring	
	9820 4791 00 •	1	Instruction	

## Service kits

1

Ref.	Part number	Qty	Name	Remarks
	<b>2901 1108 00</b>	<b>1</b>	<b>Oil pump kit</b>	
	0102 0243 00	• 1	Pin	
	0661 1000 43	• 1	Seal washer	
	0663 2106 1	• 1	O-ring	
	0663 2108 15	• 1	O-ring	
	1625 7488 0	• 1	Ring	
	1613 4120 0	• 1	Eccentric ring	
	1613 4121 0	• 1	Oil pump	
	1622 1148 0	• 2	Disc spring	
	0337 0009	• 1	Parallel key	
	0663 3132 0	• 1	O-ring	
	9820 5469	• 1	Instruction	
	<b>2901 1112 00</b>	<b>1</b>	<b>Drive shaft bearing kit</b>	
	0502 2110	• 2	Ball bearing	
	0663 2108 3	• 1	O-ring	
	0663 2106 16	• 1	O-ring	
	0663 2108	• 1	O-ring	
	0666 6000 2	• 1	Radial lip seal	
	1622 1120 0	• 1	Bushing	
	0663 2101	• 1	O-ring	
	0663 3132 0	• 1	O-ring	
	9820 5468 0	• 1	Instruction	
	<b>2901 1866 00</b>	<b>1</b>	<b>LP element exchange kit</b>	
	0663 2104 77	• 1	O-ring	
	0661 1000 40	• 1	Seal washer	
	0663 2106	• 1	O-ring	
	0211 1407 00	• 1	Cap screw	
	0663 2102 8	• 1	O-ring	
	0634 1000	• 1	Seal	
	0663 2104 26	• 1	O-ring	
	1202 8364 00	• 1	Washer	
	0634 1000 8	• 1	Seal	
	9820 5638	• 1	Instruction	
	<b>2901 1865 00</b>	<b>1</b>	<b>HP element exchange kit</b>	
	0663 2104 76	• 1	O-ring	
	0663 2104 72	• 1	O-ring	
	0663 2106 11	• 1	O-ring	
	0663 2107 77	• 1	O-ring	
	0634 1000	• 2	Seal	
	0663 2108 0	• 1	O-ring	
	0663 2106	• 1	O-ring	
	0211 1407 00	• 1	Cap screw	
	0663 2102	• 1	O-ring	
	0634 1000	• 1	Seal	
	0339 1000	• 2	Ring spring	
	1202 8364	• 1	Washer	
	0663 2106	• 1	O-ring	
	9820 5636 00	• 1	Instruction	

## 1

## Service kits

Ref.	Part number	Qty	Name	Remarks
	<b>2901 1867 00</b>	<b>1</b>	<b>Cooler kit ZT</b>	
	0392 1100 •	4	Vibration damper	
	0392 1100 37 •	2	Vibration damper	
	0634 1000 83 •	1	Seal	
	0663 2102 •	2	O-ring	
	0663 2106 11 •	1	O-ring	
	9820 5628 00 •	1	Instruction	
	<b>3001 1503 20</b>	<b>1</b>	<b>Cooler kit ZR</b>	
	0686 4201 03 •	1	Plug	
	0686 3716 0 •	2	Plug	
	0661 1000 •	2	Seal	
	1614 6256 •	4	O-ring	
	1614 6258 0 •	1	Division rib	
	1614 6259 0 •	1	Seal	
	0663 2106 •	2	O-ring	
	9820 7344 04 •	1	Instruction	
			<b>Wearing parts EWD 330</b>	
	<b>2901 0633</b>	2	Pack	
	<b>2901 0633 20</b>	3	Full Feature ID	
	<b>2901 0633 20</b>	4	Full Feature IMD	
		<b>1</b>	<b>Motor bearing kit</b>	
	<b>2901 1811 00</b>		ZR/ZT 30	
	<b>2901 1812 00</b>		ZR/ZT 37	
	<b>2901 1812 00</b>		ZR/ZT 45	
	1622 1136 02		Rubber element coupling	
	5112 2165 00	2	Vibration damper gearcasing	
	1619 5189 01	1	Vibration damper motor	

## Service kits

1

Ref.	Part number	Qty	Name	R marks
	<b>2901 1122 00</b>		<b>Preventive maintenance kit (A) Service Plan A - 4000hrs</b>	
	2901 1105 •	1	Air/oil filter kit	
	2901 1115 00 •	1	Breather kit	
	<b>2901 1874 00</b>		<b>Preventive maintenance kit (B) Service Plan B - 8000hrs</b>	1)
	2901 1122 •	1	Preventive maintenance kit (A)	
	2901 1101 00 •	1	Inlet valve service kit	
	<b>2901 1601 00</b>		<b>Preventive maintenance kit IMD 8000hrs</b>	
	1617 5143 00 •	1	Strainer	
	1617 5126 •	1	Demister	
	1617 5380 •	1	Seal ring	
	0663 2111 67 •	1	O-ring	
	0663 2105 97 •	1	O-ring	
	0301 2358 00 •	2	Washer	
	9820 4864 •	1	Instruction	
	<b>2901 1883 00</b>		<b>Preventive maintenance kit (C) Service Plan C - 16000hrs</b>	1)
	290 •	1	Preventive maintenance kit (B)	1)
	2901 1864 •	1	Check valve kit	
	2901 1104 0 •	1	Inlet valve overhaul kit	
	1622 1136 02 •	8	Rubber element coupling	
	<b>2901 1889 00</b>		<b>Preventive maintenance kit (D) Service Plan D - 40000hrs</b>	1) 2)
	2901 1883 0 •	1	Preventive maintenance kit (C)	1)
	2901 1108 00 •	1	Oil pump kit	
	2901 1865 •	1	HP element exchange kit	
	2901 1866 0 •	1	LP element exchange kit	
	2901 1112 •	1	Drive shaft bearing kit	
	1616 7275 81	1	LP element	
	1616 7271 8		HP element	

- 1) Wearing parts for EWD 330 are not included in the Preventive maintenance kit.  
They need to be ordered separately depending on the number of EWD 330 installed.
- 2) Vibration dampers are not included in the Preventive maintenance kit.  
They need to be ordered separately.



## Drive arrangement

2

Ref.	Part number	Qty	Name	Remarks
1010	1622 1140 00	1	Drive shaft	
1020	0211 1327 00	8	Cap screw	
1030	0502 2110 00	2	all bearing	
1040	0663 2101 55	1	O-ring	
1050	1622 1120 00	1	ushing	
1070	0339 1000 02	2	Clamping sleeve	
1080	1202 8364 00	1	Washer	
1090	0211 1407 00	1	Cap screw	
1100	0663 2104 77	1	O-ring	
1110	0101 1621 00	2	Pin	
1120	0147 1326 03	8	Hexagon bolt	
1140	0339 1000 02	2	Clamping sleeve	
1150	1202 8364 00	1	Washer	
1160	0211 1407 00	1	Cap screw	
1170	0663 2104 76	1	O-ring	
1180	0663 2104 72	1	O-ring	
1190	0101 1621 00	2	Pin	
1200	0147 1326 03	6	Hexagon bolt	
1210	1622 5994 00	1	Coupling housing	
1220	0666 6000 20	1	Radial lip seal	
1230	0663 2108 39	1	O-ring	
1240	0147 1403 03	8	Hexagon bolt	
1250	1622 1136 00	1	Half coupling	
1255	1622 11	• 8	Coupling element	
1260	0337 8229 00	1	Parallel key	
1270	1613 4128 00	1	Washer	
1280	0147 1407 03	1	Hexagon bolt	
1290	1622 1135 00	1	Half coupling	
1295	0196 1	• 1	Set screw	
1300	0147 1477 03	4	Hexagon bolt	
2010	1622 5997 80	1	earcasing	
2015	0211 1	• 20	Screw	
2040	0852 0010 26	1	Drain valve	
2050	0686 3716 02	1	Plug	
2060	0661 1000 39	1	Washer	
2070	1503 0202 00	1	Oil sight glass	
2075	1625 8542 00	1	Label	
2090	0686 3716 02	1	Plug	
2100	0661 1000 39	1	Washer	
2110	1622 5810 00	1	Valve	
2120	1202 5180 00	1	Spring	
2130	1622 5806 00	1	Plug	
2140	0663 2102 63	1	O-ring	
2150	1614 8747 00	1	Oil filter	
2160	1622 1146 00	1	Nipple	
2180	0686 3716 02	2	Plug	
2190	0661 1000 39	2	Washer	
3010	1622 1147 00	1	Cover	
3020	1624 1633 05	1	Filter element	
	0663 9032	• 1	O-ring	
3030	1624 1633 09	1	ilter element	
	0663 7115 00	• 1	O-ring	
3040	0663 2107 84		O-ring	
3050	0663 2107 81	2	O-ring	





## Drive arrangement

2

Ref.	Part number	Qty	Name	Remarks
3060	0211 1325 03	3	Cap screw	
3070	0686 3716 01	1	Plug	
3080	0661 1000 38	1	Seal washer	
3090	0583 8120 74	1	Fitting pipe	
3100	0070 6002 03	R	Tube	
3110	0583 8100 69	1	fitting pipe	
3130	1089 0640 43	1	Solenoid valve	
3160	1503 2564 02	1	Nipple	
4010	1622 1148 00	2	Disc spring	
4020	1625 7488 00	1	Ring	
4030	0337 0009 52	1	Parallel key	
4040	1613 4121 00	1	Oil pump	
4050	1613 4120 00	1	eccentric ring	
4060	0102 0243 00	1	Pin	
5010	1622 1672 00	1	Cover	
5020	0663 2106 16	1	O-ring	
5030	0663 3132 00	1	O-ring	
5040	0147 1369 03	3	Hexagon bolt	
5050	0301 2344 00	3	Washer	
6010	1616 7271 81	1	Element HP	
6020	1616 7275 81	1	Element LP	
		1	Gear set	
	1608 0902 21		ZT 30 7.5 bar(e) 60 Hz HAV	
	1608 0902 35		ZR/ZT 30 7.5 bar(e) 50 Hz	
	1608 0902 24		ZR/ZT 30 7.5 bar(e) 50 Hz HAV	
	1608 0902 20		ZR/ZT 30 7.5 bar(e) 60 Hz	
	1608 0902 24		ZR/ZT 30 8.6 bar(e) 50 Hz	
	1608 0902 20		ZR/ZT 30 8.6 bar(e) 50 Hz HAV	
	1608 0902 21		ZR/ZT 30 8.6 bar(e) 60 Hz	
	1608 0902 45		ZR/ZT 30 8.6 bar(e) 60 Hz HAV	
	1608 0902 27		ZR/ZT 37 7.5 bar(e) 50 Hz	
	1608 0902 40		ZR/ZT 37 7.5 bar(e) 50 Hz HAV	
	1608 0902 41		ZR/ZT 37 7.5 bar(e) 60 Hz	
	1608 0902 18		ZR/ZT 37 7.5 bar(e) 60 Hz HAV	
	1608 0902 22		ZR/ZT 37 8.6 bar(e) 50 Hz	
	1608 0902 29		ZR/ZT 37 8.6 bar(e) 50 Hz HAV	
	1608 0902 18		ZR/ZT 37 8.6 bar(e) 60 Hz	
	1608 0902 46		ZR/ZT 37 8.6 bar(e) 60 Hz HAV	
	1608 0902 39		ZR/ZT 45 7.5 bar(e) 50 Hz	
	1608 0902 42		ZR/ZT 45 7.5 bar(e) 50 Hz HAV	
	1608 0902 43		ZR/ZT 45 7.5 bar(e) 60 Hz	
	1608 0902 22		ZR/ZT 45 7.5 bar(e) 60 Hz HAV	
	1608 0902 42		ZR/ZT 45 8.6 bar(e) 50 Hz	
	1608 0902 47		ZR/ZT 45 8.6 bar(e) 50 Hz HAV	
	1608 0902 22		ZR/ZT 45 8.6 bar(e) 60 Hz	
	1608 0902 29		ZR/ZT 45 8.6 bar(e) 60 Hz HAV	
7010		• 1	Gear	
7020		• 2	Gear	





3

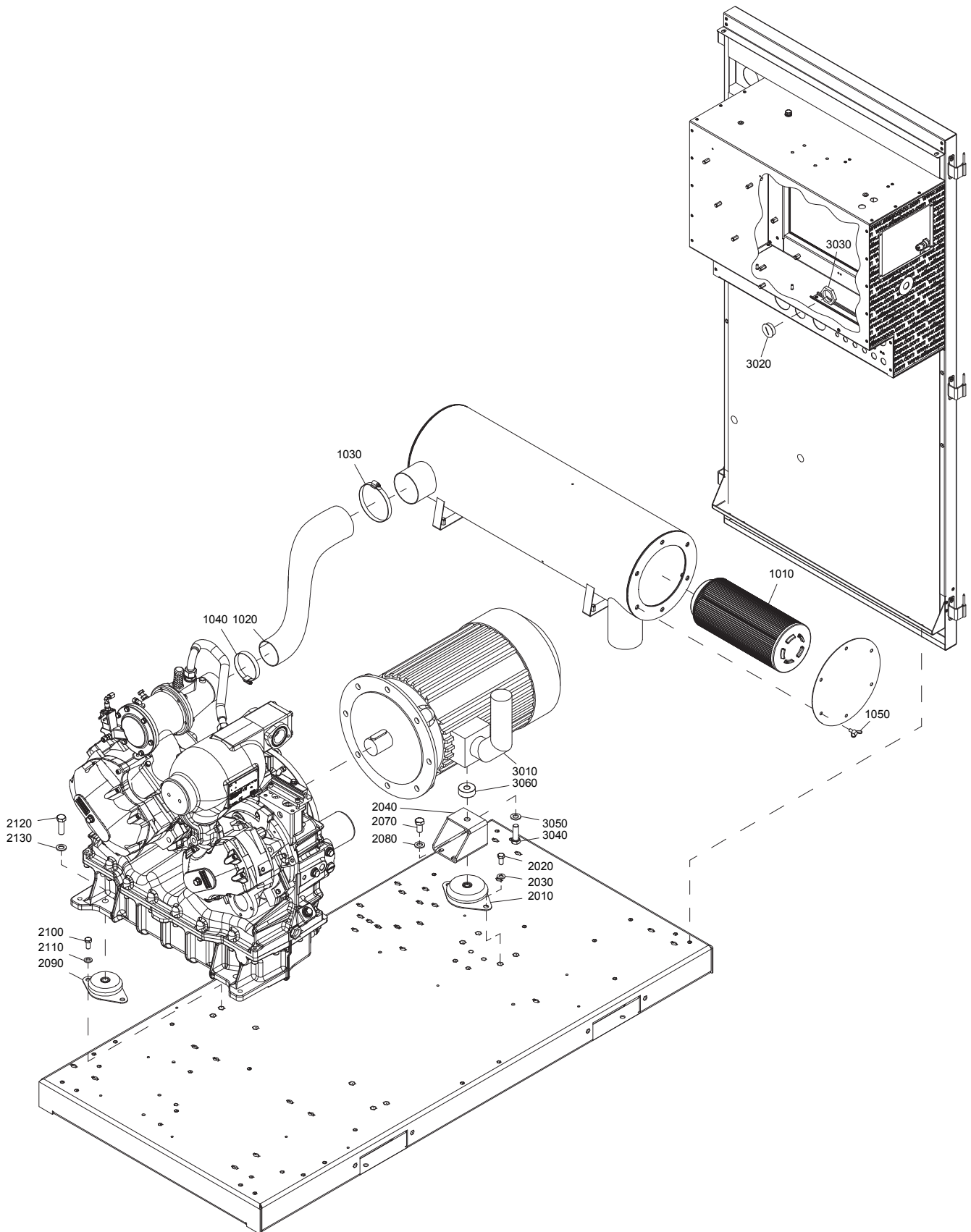

## Mounting on frame, motor and air inlet

3

Ref.	Part number	Qty	Name	Remarks
1010	1613 7407 00	1	Air filter	
1020	1622 5834 00	1	Hose	
1030	0347 6115 00	1	Hose clip	
1040	0347 6116 00	1	Hose clip	
1050	0223 1322 02	4	Wing screw	
2010	1619 5189 01	1	Rubber buffer	
2020	0147 1400 03	2	Hexagon bolt	
2030	0301 2358 00	2	Washer	
2040	1622 2659 00	1	Support	
2070	0147 1475 03	1	Hexagon bolt	
2080	0301 2378 00	1	Washer	
2090	5112 2165 00	2	Rubber buffer	
2100	0147 1400 03	4	Hexagon bolt	
2110	0301 2358 00	4	Washer	
2120	0147 1479 03	2	Hexagon bolt	
2130	0301 2378 00	2	Washer	
3010		1	Motor	
	1625 8847 61		ZR/ZT 30 200V/50Hz IEC	
	1625 8847 61		ZR/ZT 30 200V/50Hz IEC HAV	
	1080 4155 67		ZR/ZT 30 200V/60Hz IEC	
	1080 4155 67		ZR/ZT 30 200V/60Hz IEC HAV	
	1625 8847 62		ZR/ZT 30 230V/50Hz IEC	
	1625 8847 62		ZR/ZT 30 230V/50Hz IEC HAV	
	1080 4155 69		ZR/ZT 30 230V/60Hz IEC	
	1080 4155 69		ZR/ZT 30 230V/60Hz IEC HAV	
	1080 4155 69		ZR/ZT 30 230V/60Hz UL-cUL	
	1080 4155 69		ZR/ZT 30 230V/60Hz UL-cUL HAV	
	1625 8847 65		ZR/ZT 30 380V/60Hz IEC	
	1625 8847 65		ZR/ZT 30 380V/60Hz IEC HAV	
	1625 8847 63		ZR/ZT 30 400V/50Hz IEC	
	1625 8847 63		ZR/ZT 30 400V/50Hz IEC HAV	
	1625 8847 91		ZR/ZT 30 400V/50Hz IEC	1)
	1080 4155 68		ZR/ZT 30 460V/60Hz IEC	
	1080 4155 68		ZR/ZT 30 460V/60Hz IEC HAV	
	1080 4155 68		ZR/ZT 30 460V/60Hz UL-cUL	
	1080 4155 68		ZR/ZT 30 460V/60Hz UL-cUL HAV	
	1080 4155 88		ZR/ZT 30 460V/60Hz UL-cUL	1)
	1625 8847 64		ZR/ZT 30 500V/50Hz IEC	
	1625 8847 64		ZR/ZT 30 500V/50Hz IEC HAV	
	1080 4155 66		ZR/ZT 30 575V/60Hz UL-cUL	
	1080 4155 66		ZR/ZT 30 575V/60Hz UL-cUL HAV	
	1625 8847 71		ZR/ZT 37 200V/50Hz IEC	
	1625 8847 71		ZR/ZT 37 200V/50Hz IEC HAV	
	1080 4156 67		ZR/ZT 37 200V/60Hz IEC	
	1080 4156 67		ZR/ZT 37 200V/60Hz IEC HAV	
	1625 8847 72		ZR/ZT 37 230V/50Hz IEC	
	1625 8847 72		ZR/ZT 37 230V/50Hz IEC HAV	
	1080 4156 69		ZR/ZT 37 230V/60Hz IEC	
	1080 4156 69		ZR/ZT 37 230V/60Hz IEC HAV	
	1080 4156 69		ZR/ZT 37 230V/60Hz UL-cUL	
	1080 4156 69		ZR/ZT 37 230V/50Hz UL-cUL HAV	
	1625 8847 75		ZR/ZT 37 380V/60Hz IEC	
	1625 8847 75		ZR/ZT 37 380V/60Hz IEC HAV	
	1625 8847 73		ZR/ZT 37 400V/50Hz IEC	



3

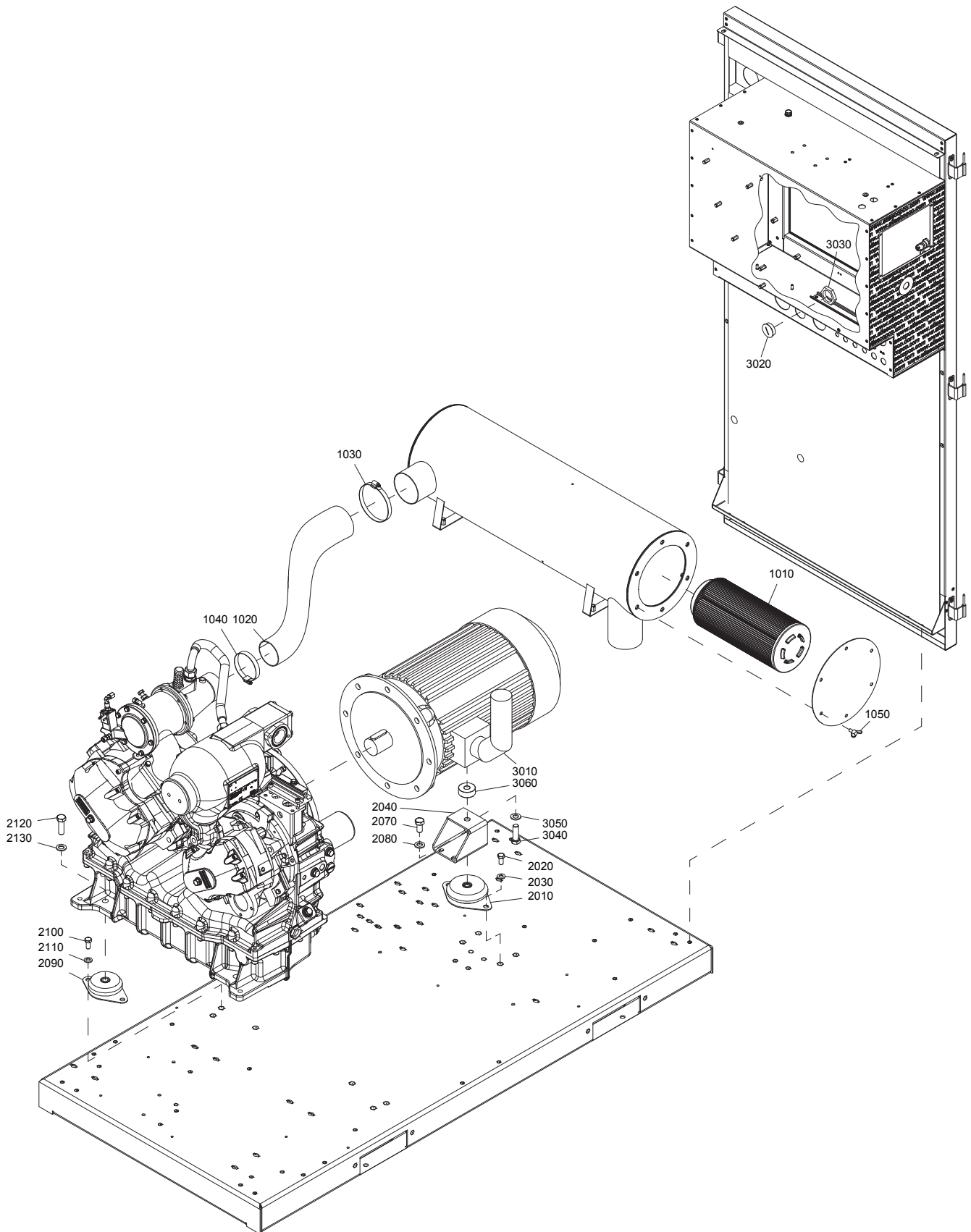

## Mounting on frame, motor and air inlet

3

Ref.	Part number	Qty	Name	Remarks
	1625 8847 73		ZR/ZT 37 400V/50Hz IEC HAV	
	1625 8847 92		ZR/ZT 37 400V/50Hz IEC	1)
	1080 4156 68		ZR/ZT 37 460V/60Hz IEC	
	1080 4156 68		ZR/ZT 37 460V/60Hz IEC HAV	
	1080 4156 68		ZR/ZT 37 460V/60Hz UL-cUL	
	1080 4156 68		ZR/ZT 37 460V/60Hz UL-cUL HAV	
	1080 4156 88		ZR/ZT 37 460V/60Hz UL-cUL	1)
	1625 8847 74		ZR/ZT 37 500V/50Hz IEC	
	1625 8847 74		ZR/ZT 37 500V/50Hz IEC HAV	
	1080 4156 66		ZR/ZT 37 575V/60Hz UL-cUL	
	1080 4156 66		ZR/ZT 37 575V/60Hz UL-cUL HAV	
	1625 8847 81		ZR/ZT 45 200V/50Hz IEC	
	1625 8847 81		ZR/ZT 45 200V/50Hz IEC HAV	
	1080 4157 67		ZR/ZT 45 200V/60Hz IEC	
	1080 4157 67		ZR/ZT 45 200V/60Hz IEC HAV	
	1625 8847 82		ZR/ZT 45 230V/50Hz IEC	
	1625 8847 82		ZR/ZT 45 230V/50Hz IEC HAV	
	1080 4157 69		ZR/ZT 45 230V/60Hz IEC	
	1080 4157 69		ZR/ZT 45 230V/60Hz IEC HAV	
	1080 4157 69		ZR/ZT 45 230V/60Hz UL-cUL	
	1080 4157 69		ZR/ZT 45 230V/60Hz UL-cUL HAV	
	1625 8847 85		ZR/ZT 45 380V/60Hz IEC	
	1625 8847 85		ZR/ZT 45 380V/60Hz IEC HAV	
	1625 8847 83		ZR/ZT 45 400V/50Hz IEC	
	1625 8847 83		ZR/ZT 45 400V/50Hz IEC HAV	
	1625 8847 93		ZR/ZT 45 400V/50Hz IEC	1)
	1080 4157 68		ZR/ZT 45 460V/60Hz IEC	
	1080 4157 68		ZR/ZT 45 460V/60Hz IEC HAV	
	1080 4157 68		ZR/ZT 45 460V/60Hz UL-cUL	
	1080 4157 68		ZR/ZT 45 460V/60Hz UL-cUL HAV	
	1080 4157 88		ZR/ZT 45 460V/60Hz UL-cUL	1)
	1625 8847 84		ZR/ZT 45 500V/50Hz IEC	
	1625 8847 84		ZR/ZT 45 500V/50Hz IEC HAV	
	1080 4157 66		ZR/ZT 45 575V/60Hz UL-cUL	
	1080 4157 66		ZR/ZT 45 575V/60Hz UL-cUL HAV	
3020		1	Plug	
	0697 9810 29		IEC	
	0697 9810 38		UL-cUL	
3030		1	Lock nut	
	0697 9809 24		IEC	
	0697 9809 06		UL-cUL	
3040		1	Hexagon bolt	
	0147 1479 03		ZR/ZT 30	
	0147 1475 03		ZR/ZT 37	
	0147 1475 03		ZR/ZT 45	
3050	0301 2378 00	1	Washer	
3060		1	Spacer	
	1622 2660 01		ZR/ZT 30	

1) For Standard option - Anti-condensation heaters and thermistors



4

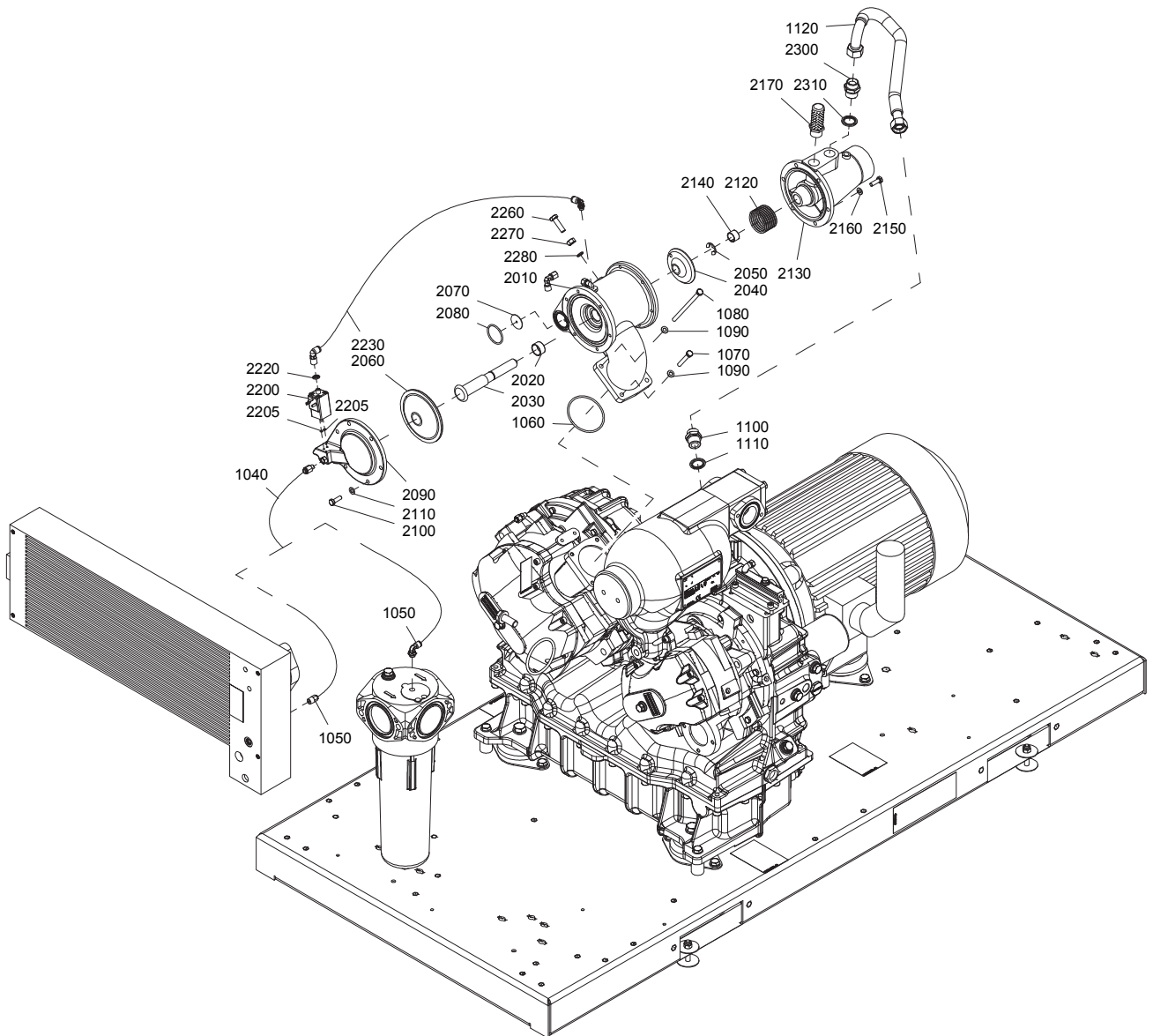

## Air system - Inlet throttle valve

4

Ref.	Part number	Qty	Name	Remarks
1030	0583 8100 76	1	Pipe coupling	
1040	0070 6002 03	R	Tube	
1050		1	Pipe coupling	
	0583 8120 74		ZR	
	0583 8100 69		ZT	
1060	0663 2104 26	1	O-ring	
1070	0147 1331 03	2	Hexagon bolt	
1080	0147 1345 03	2	Hexagon bolt	
1090	0301 2335 00	4	Washer	
1100	0571 0035 75	1	Nipple	
1110	0661 1000 43	1	Seal washer	
1120	1622 2664 00	1	Pipe	
	<b>1622 1111 82</b>	<b>1</b>	<b>Inlet throttle valve</b>	
2010		• 1	Valve housing	
2020	0500 4510 27	• 1	Bearing	
2030	1613 5	• 1	Valve	
2040	1622 1583 00	• 1	Valve	
2050	0335 3114 00	• 1	Retaining ring	
2060	1621 1005 00	• 1	Diaphragm	
2070	1613 4	• 1	Membrane	
2080	0663 2108 16	• 1	O-ring	
2090	1622 11	• 1	Valve cover	
2100	0147 1325 03	• 6	Hexagon bolt	
2110	0301 2335 00	• 6	Washer	
2120	1613 5721 00	• 1	Spring	
2130	1622 1671 01	• 1	Connection	
2140	0500 4510 01	• 1	Bushing	
2150	0147 1325 03	• 6	Hexagon bolt	
2160	0301 2335 00	• 6	Washer	
2170	1614 6819 00	• 1	Muffler	
<b>2200</b>	<b>1089 0428 13</b>	<b>• 1</b>	<b>Solenoid valve</b>	
2205	0663 21	•• 2	O-ring	
2220	0661 1000 42	• 1	Seal washer	
2225	0583 8121 23	• 1	Fitting pipe	
2230	0070 6	• AR	Plastic tube	
2240	0583 8120 75	• 1	Fitting	
2260	0147 1	• 1	Hexagon bolt	
2270	0266 2111 00	• 1	Nut	
2280	0661 1000 42	• 1	Seal washer	
2300	0571 0035 75	• 1	Nipple	
2310	0661 1000 43	• 1	Seal washer	











## COMMITTED TO SUPERIOR PRODUCTIVITY

### **In-house development & testing**

Since 1998, our dedicated filtration team is responsible for in-house development of cutting-edge filtration solutions. This results in expert know-how of filtration mechanisms, state-of-the-art test facilities and breakthrough innovations. For many years, our filtration team has cooperated closely with the University of Karlsruhe, a leading institute in research of filtration mechanisms.

### **Rigorous quality control**

To ensure the highest standards, all Atlas Copco products are subjected to rigorous quality control testing. The entire filter range is produced in-house, on the most advanced production lines, using the most stringent methods in the industry. You can rest assured at all times that strict certification and testing procedures are conducted to ensure our filtration products meet the highest standards.



# THE ATLAS COPCO SOLUTION

Compressed air can be contaminated by dirt, water and oil, which can be further divided as follows:

- **DIRT:** micro-organisms, dust, solid particles, rust particles.
- **WATER:** water vapor, condensed liquid water, water aerosols, acidic condensates.
- **OIL:** liquid oil, oil aerosol, hydrocarbon vapor.

Atlas Copco offers a wide selection of filtration solutions and application knowledge. Different product types and grades are available to meet your every demand. Only genuine spare cartridges guarantee the Atlas Copco filter performance.



## Welded design

6 grades  
12 sizes  
550 → 8,000 l/s  
1,200 → 17,000 cfm

## Tower design

1 grade  
14 sizes  
20 → 1800 l/s  
42 → 3814 cfm

20 bar / 290 psi  
50 bar / 725 psi  
100 bar / 1,450 psi  
350 bar / 5,075 psi

## Threaded design

5 grades  
9 sizes  
15 → 944 l/s  
32 → 2,000 cfm

## Threaded design

5 grades  
11 sizes  
9 → 520 l/s  
19 → 1,102 cfm

## Threaded design

1grade  
10 sizes  
400 → 6,700 l/min  
14 → 237 cfm



## Cast design

6 grades  
13 sizes  
9 → 550 l/s  
19 → 1,200 cfm



850 → 1,100 l/s  
1,801 → 2,331 cfm



Name	DDp+	PDp+	DD+	PD+	UD+	QD+	QDT	H High pressure		SFA Silicone-free			MV Medical vacuum	
	DDp	PDp	DD	PD		QD		Rough & Fine		Rough & Fine	Basic	Rough & Fine	Basic	Fine
Grade	Rough	Fine	Rough	Fine	Ultimate	Basic	Optimal	Rough & Fine	Rough & Fine	Basic	Rough & Fine	Rough & Fine	Basic	Fine
Contaminant	Dry dust		Oil aerosol / wet dust			Oil vapor		Rough & Fine	Rough & Fine	Basic	Rough & Fine	Rough & Fine	Basic	Dry dust
General applications								Special applications						



Dry dust



Micro-organisms



Oil aerosol



Wet dust



Oil vapor



Water drops

# CERTIFIED PERFORMANCE

Atlas Copco filters are qualified according to the ISO 8573-1:2010 standard. This is the latest edition of the standard. Beware of filters that comply with earlier editions, such as ISO 8573-1:1991 or ISO 8573-1:2001. The difference is inferior quality of the delivered compressed air. This qualification is a result of our filters being tested according to ISO 12500-1:2007, ISO 12500-2:2007, and ISO 12500-3:2009. These specify the test layout, test procedures and inlet conditions required for testing coalescing filters, vapor filters, and solid particle filters used in compressed air systems, to determine their effectiveness in removing oil aerosol, oil vapor and solid particles. The measurements of the air purity downstream the filter for each specific contaminant have been performed according to the test methods described in respectively ISO 8573-2:2007, ISO 8573-5:2001 and ISO 8573-4:2001. Tests have been conducted in-house as well as in external labs, and are independently validated by TÜV.

## ISO certification

Atlas Copco's filters have been fully tested and qualified according to the following ISO standards:

- ISO 8573-1:2010: Compressed air - Contaminants and purity classes
- ISO 8573-2:2007: Compressed air - Test method for oil aerosol content
- ISO 8573-4:2001: Compressed air - Test method for dust
- ISO 8573-5: 2001: Compressed air - Test method for oil vapor and organic solvent content
- ISO 12500-1:2007: Filters for compressed air - test methods - oil aerosols
- ISO 12500-2:2007: Filters for compressed air - test methods - oil vapors
- ISO 12500-3:2009: Filters for compressed air - test methods - particulates



## Certified peace of mind

<b>FILTER APPROVALS</b>	<b>COMPANY CERTIFICATION</b>
CE ASME CRN	® ® ®
<b>ACTIVE MEMBER OF</b>	
pneurop CAGI bcas VDMA	

# A SOLUTION FOR EVERY APPLICATION

At different points of use, different compressed air purities might be needed, depending on the application. The various air purity classes are provided in the table below, which clearly shows the various Atlas Copco filters and dryers that meet all the different classes.

ISO 8573-1:2010 CLASS	Solid particles		Water	Oil (= aerosol, liquid, vapor)
	Wet conditions	Dry conditions		
0	As specified by the customer*			Oil-free compressor
1	DD+ & PD+	DDp+ & PDp+	Desiccant dryer	DD+ & PD+ & QD+/QDT
	UD+			UD+ & QD+/QDT
2	DD+	DDp+	Desiccant dryer	DD+ & PD+ UD+
3	DD+	DDp+	Desiccant dryer, membrane dryer, rotary drum dryer	DD+
4	DD+	DDp+	Membrane dryer, refrigerant dryer	DD+
5	DD+	DDp+	Membrane dryer, refrigerant dryer	-
6	-	-	Membrane dryer, refrigerant dryer	-

\* Please contact your Atlas Copco sales representative.

## Examples of typical installations

<b>A</b>	Compressor - UD+	Air purity class ISO 8573-1:2010 [1:-:2]
<b>B</b>	Compressor - UD+ - Refrigerant dryer	Air purity class ISO 8573-1:2010 [1:4:2]*
<b>C</b>	Compressor - UD+ - Refrigerant dryer - QDT - DDp+	Air purity class ISO 8573-1:2010 [2:4:1]
<b>D</b>	Compressor - UD+ - Desiccant dryer - DDp+	Air purity class ISO 8573-1:2010 [2:2:2]
<b>E</b>	Compressor - UD+ - Desiccant dryer - QDT - DDp+ - PDp+	Air purity class ISO 8573-1:2010 [1:2:1]

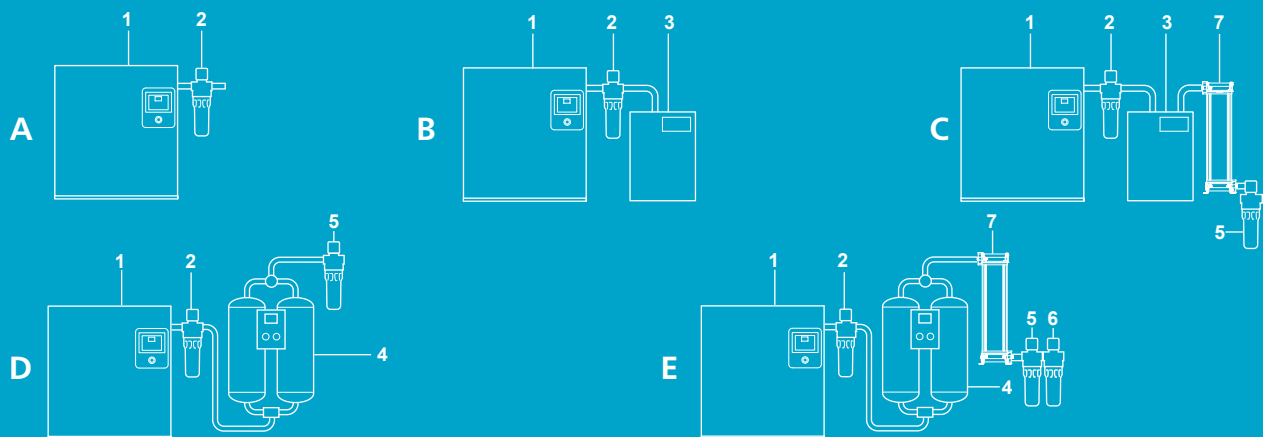

**1.** Compressor  
**2.** UD+ filter

**3.** Refrigerant dryer  
**4.** Desiccant dryer

**5.** DDp+ filter  
**6.** PDp+ filter

**7.** QDT filter

\* Particle class 1 is reached directly after UD+. As downstream piping & vessels can add particles, it is advised to install particle filters DDp+ and PDp+ just before the application to reach particle class 1 at point of use.

The compressor should be equipped with a liquid water separation system such as an after cooler including a drain or a water separator (WSD). Always install a water separator in front of a coalescence filter. In case of critical applications, install extra air treatment products at point of use for the removal of pipeline contamination and condensation.

# UD+ SERIES

## Two-in-one oil coalescing filters with supreme energy savings

UD+ filters efficiently reduce oil aerosol, wet dust and water drops in your compressed air stream to protect your investment, equipment and processes. The UD+ combines two filtration steps (DD+ and PD+) into one, a unique technology to meet the high-quality requirements of diverse applications and provide ultimate energy savings.



## YOUR BENEFITS

### 40% energy savings

A 40% lower pressure drop than the conventional filter combination results in 40% higher energy efficiency.

### Pure air

Air purity is equal to that obtained using two filters in line, thanks to the thick filter package of UD+ filters.

### Save space

The two-in-one filtration concept reduces installation space and complexity, making UD+ filters particularly suitable for applications where space is at a premium.

### Save money

Install UD+ filters to enjoy significant cost savings compared to conventional filters.

## Performance

	UD+
Contaminant	Oil aerosol/wet dust
Test method	ISO 8573-2:2007, ISO 12500-1:2007
Maximum oil carry-over (mg/m <sup>3</sup> )*	0.0009
Wet pressure drop (mbar)	245
Element service	After 4,000 operating hours or 1 year
Precede with	Water separation

\* Inlet oil concentration = 10 mg/m<sup>3</sup>. Oil = oil aerosol and liquid.

## Sizing & dimensions

FILTER SIZE UD+	Nominal capacity		Reference pressure		Maximum pressure		Connections	Dimensions						Free space for cartridge replacement		Weight	
								A		B		C		D			
	l/s	cfm	bar(e)	psig	bar(e)	psig	in	mm	in	mm	in	mm	in	mm	in	kg	lbs
9+	9	19	7	102	16	232	3/8	90	3.5	61	2.4	268	10.6	75	2.9	1.0	2.2
15+	15	32	7	102	16	232	1/2	90	3.5	61	2.4	268	10.6	75	2.9	1.1	2.4
25+	25	53	7	102	16	232	1/2	90	3.5	61	2.4	323	12.8	75	2.9	1.3	2.9
45+	45	95	7	102	16	232	3/4 & 1	110	4.3	99	3.9	374	14.7	75	2.9	1.6	4.2
60+	60	127	7	102	16	232	1	110	4.3	99	3.9	414	16.3	75	2.9	2.1	4.6
100+	100	212	7	102	16	232	1	140	5.5	105	4.0	425	16.7	100	3.9	3.7	8.2
140+	140	297	7	102	16	232	1-1/2	140	5.5	105	4.1	520	20.5	100	3.9	4.2	9.3
180+	180	381	7	102	16	232	1-1/2	140	5.5	105	4.1	603	23.7	100	3.9	4.5	9.9
220+	220	466	7	102	16	232	1-1/2	140	5.5	105	4.1	603	23.7	100	3.9	4.6	10.1
310+	310	657	7	102	16	232	2 & 2-1/2	179	7.1	121	4.8	689	27.1	150	5.9	6.9	15.2
425+	425	901	7	102	16	232	3	210	8.3	128	5.1	791	31.1	200	7.9	11.0	24.2
550+	550	1165	7	102	16	232	3	210	8.3	128	5.1	961	37.8	200	7.9	12.6	27.8
550+F	550	1165	7	102	16	232	DN80	370	14.6	280	11.0	1295	51.0	1375	54.1	76.0	167.6
850+T	850	1.801	7	102	16	232	DN100	510	20.1	418	16.5	796	31.3	200	7.9	35.2	77.6
850+F	850	1801	7	102	16	232	DN100	510	20.1	410	16.1	1360	53.5	1500	59.1	141.0	310.9
1100+T	1.100	2.331	7	102	16	232	DN100	510	20.1	418	16.5	966	38.0	200	7.9	37.4	82.4
1100+F	1100	2331	7	102	16	232	DN100	510	20.1	410	16.1	1360	53.5	1500	59.1	143.0	315.3
1400+F	1400	2967	7	102	16	232	DN150	620	24.4	485	19.1	1480	58.3	1560	61.4	210.0	463.0
1800+F	1800	3814	7	102	16	232	DN150	640	25.2	490	19.3	1555	61.2	1640	64.6	176.0	388.0
2200+F	2200	4662	7	102	16	232	DN150	640	25.2	490	19.3	1555	61.2	1640	64.6	178.0	392.4
3000+F	3000	6357	7	102	16	232	DN200	820	32.3	650	17.7	1745	68.7	1710	67.3	420.0	925.9
4000+F	4000	8476	7	102	16	232	DN200	820	32.3	650	17.7	1745	68.7	1710	67.3	428.0	943.6
5000+F	5000	10595	7	102	16	232	DN200	820	32.3	650	17.7	1745	68.7	1710	67.3	432.0	952.4
6000+F	6000	12714	7	102	16	232	DN250	920	36.2	815	32.1	2085	82.1	1625	64.0	671.0	1479.3
7000+F	7000	14833	7	102	16	232	DN250	920	36.2	815	32.1	2085	82.1	1625	64.0	675.0	1488.1
8000+F	8000	16952	7	102	16	232	DN300	1040	40.9	930	36.6	2070	81.5	1625	64.0	900.0	1984.2

## Correction factors

Inlet pressure (bar)	1	2	3	4	5	6	7	8	10	12	14	16
Inlet pressure (psig)	15	29	44	58	72.5	87	102	116	145	174	203	232
Correction factor	0.38	0.53	0.65	0.75	0.83	0.92	1.00	1.06	1.20	1.31	1.41	1.50

### Example

- Working pressure 3 bar(g), compressed air flow 35 l/s.
- Multiply the nominal capacity of the selected filter with the corresponding correction factor at the required working pressure to obtain the capacity at working pressure:
  - Size 45+: 45 l/s \* 0.65 = 29 l/s => the 45+ filter size is not large enough.
  - Size 60+: 60 l/s \* 0.65 = 39 l/s => the 60+ filter size is the size to select.

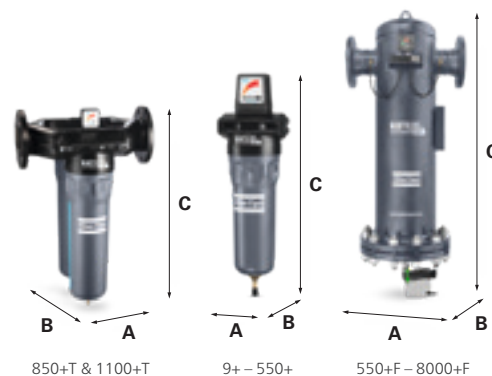

## Options

- Filter connection kit for easy mounting in series (9-550 l/s).
- Wall mounting kit simplifies installation (9-550 l/s).
- Quick coupling connects the filter with a drain or oil/water separator.
- Voltage-free contact mounted in the differential pressure gauge, to give remote indication of cartridge replacement.
- EWD electronic drain with no loss of compressed air and an alarm function (EWD is optional on size 9+ - 550+, 850+T and 1100+T; standard on size 550+F and larger).

## Certification

- ISO 8573-2:2007
- ISO 12500-1:2007



# DD(+)/PD(+) SERIES

## High performance oil coalescing filters

DD(+) and PD(+) filters efficiently reduce oil aerosol, wet dust and water drops in your compressed air stream. These could come from the lubrication of the compressor element, the intake air, and the compressor installation itself. These innovative filtration solutions are engineered to cost-effectively provide the best air purity and meet today's increasing quality demands.



## YOUR BENEFITS

### Maximum oil aerosol, wet dust and water droplet filtration and drainage

High-efficient glass fiber and foam media.

### Significant energy savings & limited system operating costs

Optimal design and filter media allow low pressure losses.

### High reliability

High-performance stainless steel cores, double O-rings, epoxy sealed caps, and anti-corrosive coated filter housing.

### Easy maintenance

External ribs on the threaded housing, or a rotating bottom cover for the welded housings, and push-on elements.

### Monitoring of energy use

Differential pressure indication (indicator for sizes 10-35 l/s, gauge for sizes 50-8000 l/s) (optional for standard range).

## Performance

	DD	PD	DD+	PD+
Contaminant	Oil aerosol/wet dust			
Test method	ISO 8573-2:2007, ISO 12500-1:2007			
Maximum oil carry-over (mg/m <sup>3</sup> )*	0.1*	0.01*	0.07*	0.008*
Wet pressure drop (mbar)	245	280	180	215
Element service	After 4,000 operating hours or 1 year			
Precede with	Water separation	Water separation DD	Water separation	Water separation DD+

\* Inlet oil concentration = 10 mg/m<sup>3</sup>. Oil = oil aerosol and liquid.



## Sizing & dimensions

FILTER SIZE DD/PD		Nominal capacity				Reference pressure		Maximum pressure		Connections	Dimensions						Free space for cartridge replacement		Weight	
		Standard		+							A		B		C		D			
Standard	+	l/s	cfm	l/s	cfm	bar(e)	psig	bar(e)	psig	in	mm	in	mm	in	mm	in	mm	in	kg	lbs
12	10+	12	25	10	21	7	102	16	232	3/8	90	3.5	61	2.4	268	10.6	75	2.9	1.0	2.2
25	20+	25	53	20	42	7	102	16	232	1/2	90	3.5	61	2.4	268	10.6	75	2.9	1.1	2.4
45	35+	45	95	35	74	7	102	16	232	1/2	90	3.5	61	2.4	323	12.7	75	2.9	1.3	2.9
65	50+	65	138	50	106	7	102	16	232	3/4 & 1	110	4.3	99	3.9	374	14.7	75	2.9	1.6	4.2
90	70+	90	191	70	148	7	102	16	232	1	110	4.3	99	3.9	414	16.3	75	2.9	2.1	4.6
160	130+	160	339	130	275	7	102	16	232	1-1/2	140	5.5	105	4.1	520	20.5	100	3.9	4.2	9.3
215	170+	215	456	170	360	7	102	16	232	1-1/2	140	5.5	105	4.1	603	23.7	100	3.9	4.5	9.9
265	210+	265	562	210	445	7	102	16	232	1-1/2	140	5.5	105	4.1	603	23.7	100	3.9	4.6	10.1
360	310+	360	763	310	657	7	102	16	232	2 & 2-1/2	179	7.0	121	4.8	689	27.1	150	5.9	6.9	15.2
525	425+	525	1112	425	901	7	102	16	232	3	210	8.3	128	5.0	791	31.1	200	7.9	11.0	24.2
690	550+	690	1462	550	1165	7	102	16	232	3	210	8.3	128	5.0	961	37.9	200	7.9	12.6	27.8
630F	550+F	630	1335	550	1165	7	102	16	232	DN80	370	14.6	280	11	1295	51.0	1375	54.1	76.0	167.6
-	850+T	-	-	850	1801	7	102	16	232	DN100	510	20.1	418	16.5	796	31.3	200	7.9	35.2	77.6
970F	850+F	970	2055	850	1801	7	102	16	232	DN100	510	20.1	410	16.1	1360	53.5	1500	59.1	141.0	310.9
-	1100+T	-	-	1100	2331	7	102	16	232	DN100	510	20.1	418	16.5	966	38.0	200	7.9	37.4	82.4
1260F	1100+F	1260	2670	1100	2331	7	102	16	232	DN100	510	20.1	410	16.1	1360	53.5	1500	59.1	143.0	415.3
1600F	1400+F	1600	3390	1400	2967	7	102	16	232	DN150	620	24.4	485	19.1	1480	58.3	1560	61.4	210.0	463.0
2200F	1800+F	2200	4662	1800	3814	7	102	16	232	DN150	640	25.2	490	19.3	1555	61.2	1640	64.6	176.0	388.0
2400F	2200+F	2400	5086	2200	4662	7	102	16	232	DN150	640	25.2	490	19.3	1555	61.2	1640	64.6	178.0	392.4
3600F	3000+F	3600	7628	3000	6357	7	102	16	232	DN200	820	32.3	650	25.6	1745	68.7	1710	67.3	420.0	925.9
-	4000+F	-	-	4000	8476	7	102	16	232	DN200	820	32.3	650	25.6	1745	68.7	1710	67.3	428.0	943.6
-	5000+F	-	-	5000	10595	7	102	16	232	DN200	820	32.3	650	25.6	1745	68.7	1710	67.3	432.0	952.4
-	6000+F	-	-	6000	12714	7	102	16	232	DN250	920	32.3	815	32.1	2085	80.3	1625	64	671.0	1479.3
-	7000+F	-	-	7000	14833	7	102	16	232	DN250	920	36.2	815	32.1	2085	82.1	1625	64	675.0	1488.1
-	8000+F	-	-	8000	16952	7	102	16	232	DN300	1040	40.9	930	36.6	2070	81.5	1625	64	900.0	1984.2

## Correction factors

Inlet pressure (bar)	1	2	3	4	5	6	7	8	10	12	14	16
Inlet pressure (psig)	15	29	44	58	72.5	87	102	116	145	174	203	232
Correction factor	0.38	0.53	0.65	0.75	0.83	0.92	1.00	1.06	1.20	1.31	1.41	1.50

### Example

- Working pressure 3 bar(g), compressed air flow 35 l/s.
- Multiply the nominal capacity of the selected filter with the corresponding correction factor at the required working pressure to obtain the capacity at working pressure:
  - Size 50+: 50 l/s \* 0.65 = 33 l/s => the 50+ filter size is not large enough.
  - Size 70+: 70 l/s \* 0.65 = 46 l/s => the 70+ filter size is the size to select.

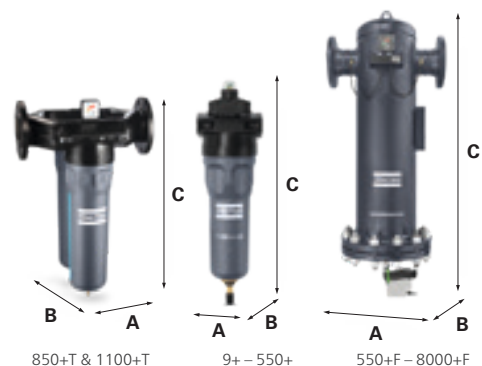

## Options

- Filter connection kit for easy mounting in series (10+ - 550+ l/s and 12-690 l/s).
- Wall-mounting kit simplifies installation (10+ - 550+ l/s and 12-690 l/s).
- Quick coupling connects the filter with a drain or oil/water separator.
- Voltage-free contact mounted in the differential pressure gauge, to give remote indication of cartridge replacement.
- EWD electronic drain with no loss of compressed air and an alarm function (EWD is optional on sizes 10+ - 550+ l/s and 12-690 l/s; standard on sizes ≥550F).

## Certification

- ISO 8573-2:2007
- ISO 12500-1:2007



EWD electronic drain

# DDp(+)/PDp(+) SERIES

## Optimal dry dust filtration

DDp(+) and PDp(+) filters efficiently prevent dust, particulates and micro-organisms arising from corrosion, dirt and adsorption material from entering your compressed air stream. These innovative filtration solutions are engineered to cost-effectively provide the best air purity and meet today's increasing quality demands.



## YOUR BENEFITS

### Maximum dirt, solid particles, micro-organisms and rust particles removal

High-efficient glass fiber and foam media.

### Significant energy savings & limited system operating costs

Optimal design and filter media allow for low pressure losses.

### High reliability

High-performance stainless steel cores, double O-rings, epoxy sealed caps, and anti-corrosive coated filter housing.

### Easy maintenance

External ribs on the threaded housing, or a rotating bottom cover for the welded housings, and push-on elements.

### Monitoring of energy use

Differential pressure indication (indicator for sizes 10-35 l/s, gauge for sizes 45-8000 l/s) (optional for standard range).

## Performance

	DDp	PDp	DDp+	PDp+
Contaminant	Dry dust			
Test method	ISO 8573-4:2001, ISO 12500-3:2009			
Particle removal efficiency (% at MPPS)	99.81	99.97	99.92	99.98
Dry pressure drop (mbar)	135	150	85	100
Element service	After 4,000 operating hours or 1 year or 350 mbar pressure drop			
Precede with	Dryer	Dryer DDp	Dryer	Dryer DDp+



## Sizing & dimensions

FILTER SIZE DDp/PDp		Nominal capacity				Reference pressure		Maximum pressure		Connections	Dimensions						Free space for cartridge replacement		Weight	
		Standard		+							A		B		C		D			
Standard	+	l/s	cfm	l/s	cfm	bar(e)	psig	bar(e)	psig	in	mm	in	mm	in	mm	in	mm	in	kg	lbs
12	10+	12	25	10	21	7	102	16	232	3/8	90	3.5	61	2.4	268	10.6	75	2.9	1.0	2.2
25	20+	25	53	20	42	7	102	16	232	1/2	90	3.5	61	2.4	268	10.6	75	2.9	1.1	2.4
45	35+	45	95	35	74	7	102	16	232	1/2	90	3.5	61	2.4	323	12.7	75	2.9	1.3	2.9
65	50+	65	138	50	106	7	102	16	232	3/4 & 1	110	4.3	99	3.9	374	14.7	75	2.9	1.6	4.2
90	70+	90	191	70	148	7	102	16	232	1	110	4.3	99	3.9	414	16.3	75	2.9	2.1	4.6
160	130+	160	339	130	275	7	102	16	232	1-1/2	140	5.5	105	4.1	520	20.5	100	3.9	4.2	9.3
215	170+	215	456	170	360	7	102	16	232	1-1/2	140	5.5	105	4.1	603	23.7	100	3.9	4.5	9.9
265	210+	265	562	210	445	7	102	16	232	1-1/2	140	5.5	105	4.1	603	23.7	100	3.9	4.6	10.1
360	310+	360	763	310	657	7	102	16	232	2 & 2-1/2	179	7.0	121	4.8	689	27.1	150	5.9	6.9	15.2
525	425+	525	1112	425	901	7	102	16	232	3	210	8.3	128	5.0	791	31.1	200	7.9	11.0	24.2
690	550+	690	1462	550	1165	7	102	16	232	3	210	8.3	128	5.0	961	37.9	200	7.9	12.6	27.8
630F	550+F	630	1335	550	1165	7	102	16	232	DN80	370	14.6	280	11	1295	51.0	1375	54.1	76.0	167.6
-	850+T	-	-	850	1801	7	102	16	232	DN100	510	20.1	418	16.5	796	31.3	200	7.9	35.2	77.6
970F	850+F	970	2055	850	1801	7	102	16	232	DN100	510	20.1	410	16.1	1360	53.5	1500	59.1	141.0	310.9
-	1100+T	-	-	1100	2331	7	102	16	232	DN100	510	20.1	418	16.5	966	38.0	200	7.9	37.4	82.4
1260F	1100+F	1260	2670	1100	2331	7	102	16	232	DN100	510	20.1	410	16.1	1360	53.5	1500	59.1	143.0	415.3
1600F	1400+F	1600	3390	1400	2967	7	102	16	232	DN150	620	24.4	485	19.1	1480	58.3	1560	61.4	210.0	463.0
2200F	1800+F	2200	4662	1800	3814	7	102	16	232	DN150	640	25.2	490	19.3	1555	61.2	1640	64.6	176.0	388.0
2400F	2200+F	2400	5086	2200	4662	7	102	16	232	DN150	640	25.2	490	19.3	1555	61.2	1640	64.6	178.0	392.4
3600F	3000+F	3600	7628	3000	6357	7	102	16	232	DN200	820	32.3	650	25.6	1745	68.7	1710	67.3	420.0	925.9
-	4000+F	-	-	4000	8476	7	102	16	232	DN200	820	32.3	650	25.6	1745	68.7	1710	67.3	428.0	943.6
-	5000+F	-	-	5000	10595	7	102	16	232	DN250	820	32.3	650	25.6	1745	68.7	1710	67.3	432.0	952.4
-	6000+F	-	-	6000	12714	7	102	16	232	DN250	920	32.3	815	32.1	2085	80.3	1625	64	671.0	1479.3
-	7000+F	-	-	7000	14833	7	102	16	232	DN300	920	36.2	815	32.1	2085	82.1	1625	64	675.0	1488.1
-	8000+F	-	-	8000	16952	7	102	16	232	DN300	1040	40.9	930	36.6	2070	81.5	1625	64	900.0	1984.2

## Correction factors

Inlet pressure (bar)	1	2	3	4	5	6	7	8	10	12	14	16
Inlet pressure (psig)	15	29	44	58	72.5	87	102	116	145	174	203	232
Correction factor	0.38	0.53	0.65	0.75	0.83	0.92	1.00	1.06	1.20	1.31	1.41	1.50

### Example

- Working pressure 3 bar(g), compressed air flow 35 l/s.
- Multiply the nominal capacity of the selected filter with the corresponding correction factor at the required working pressure to obtain the capacity at working pressure:
  - Size 50+: 50 l/s \* 0.65 = 33 l/s => the 50+ filter size is not large enough.
  - Size 70+: 70 l/s \* 0.65 = 46 l/s => the 70+ filter size is the size to select.

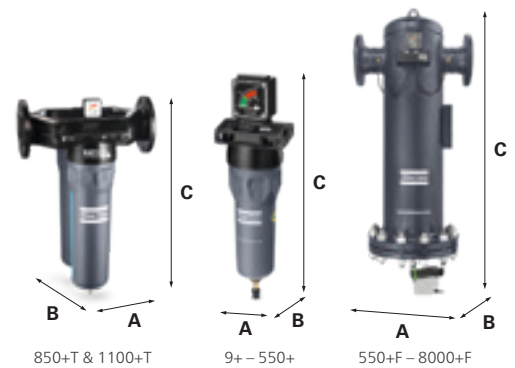

## Options

- Filter connection kit for easy mounting in series (10+ - 550+ l/s and 12-690 l/s).
- Wall-mounting kit simplifies installation (10+ - 550+ l/s and 12-690 l/s).
- Voltage-free contact mounted in the differential pressure gauge, to give remote indication of cartridge replacement.

## Certification

- ISO 8573-4:2001
- ISO 12500-3:2009

Voltage-free contact



# QDT SERIES

## Activated carbon towers for optimal oil vapor filtration

The high efficiency activated carbon tower is capable of removing hydrocarbons, odors and oil vapor from compressed air.

The activated carbon will, by the use of adsorption,

reduce the residual oil content to lower than 0.003 mg/m<sup>3</sup>.

The pressure drop is low and stays minimal during the filter's lifetime.



## YOUR BENEFITS

### Maximum oil vapor removal

Superb activated carbon material.

### Low pressure drop

Optimal internal flow path.

### High reliability

Robust design and optimal filter material.

### Options

- Oil indicator ensures pure air.
- Wall mounting kit for easy installation (20 – 185 l/s).



### Certification

ISO 8573-5:2001

## Performance

	QDT
Contaminant	Oil vapor
Test method	ISO 8573-5:2001, ISO 12500-2:2007
Maximum oil carry-over (mg/m <sup>3</sup> )*	0.003
Dry pressure drop (mbar)	125 (QDT 20-310) 72 (QDT 425-1800)
Element service	After 4,000 operating hours or 1 year
Precede with	Water separation UD+ or DD+/PD+ Dryer

\* After UD+ or DD+/PD+ with inlet oil concentration of 10 mg/m<sup>3</sup>.

## Sizing & dimensions

FILTER SIZE QDT	Nominal capacity		Connections G or NPT threaded	Dimensions						Weight	
				A		B		C			
	l/s	cfm	DIN or ANSI flanged	mm	in	mm	in	mm	in	kg	lbs
20	20	42	1/2"	490	19	223	9	190	7	10	22
45	45	95	1"	715	28	223	9	190	7	15	33
60	60	127	1"	840	33	223	9	190	7	18	40
95	95	210	1"	715	28	387	15	190	7	29	64
125	125	265	1 1/2"	840	33	387	15	190	7	34	75
150	150	318	1 1/2"	715	28	551	22	190	7	42	93
185	185	392	1 1/2"	840	33	551	22	190	7	50	110
245	245	519	1 1/2"	840	33	715	28	190	7	67	148
310	310	657	1 1/2"	840	33	879	35	190	7	84	185
425	425	901	DN80 / 3"	2148	85	710	28	600	24	264	581
550	550	1165	DN80 / 3"	2190	86	710	28	670	26	302	664
850	850	1801	DN100 / 4"	2320	91	724	29	805	32	391	860
1100	1100	2331	DN100 / 4"	2450	97	934	37	820	32	602	1324
1800	1800	3814	DN150 / 6"	2612	103	1046	41	980	39	882	1940

## Correction factors

For other compressed air inlet temperatures, please multiply the filter capacity by the following correction factor (Kt):

Inlet temperature °C	20	25	30	35	40	45	50	55	60
Inlet temperature °F	68	77	96	95	104	113	122	131	140
Correction factor	1	1	1	1	0.85	0.67	0.59	0.48	0.42

For other compressed air inlet pressures, please multiply the filter capacity by the following correction factor (Kp):

Inlet pressure bar	3	4	5	6	7	8	9	10	11	12	13
Inlet pressure psi	44	58	73	87	102	116	131	145	160	174	193
Correction factor	0.57	0.77	0.83	1	1	1	1	1.05	1.05	1.11	1.18

### Example

- Working temperature 50°C, pressure 12 bar(g), compressed air flow 120 l/s.
- Multiply the nominal capacity of the selected filter with the corresponding correction factors at the required working temperature and pressure to obtain the capacity at operating condition
  - QDT 150:  $150\text{l/s} * 0.59 * 1.11 = 98\text{l/s} \Rightarrow$  A QDT 150 filter is not large enough
  - QDT 195:  $195\text{l/s} * 0.59 * 1.11 = 128\text{l/s} \Rightarrow$  A QDT 195 filter is the correct size

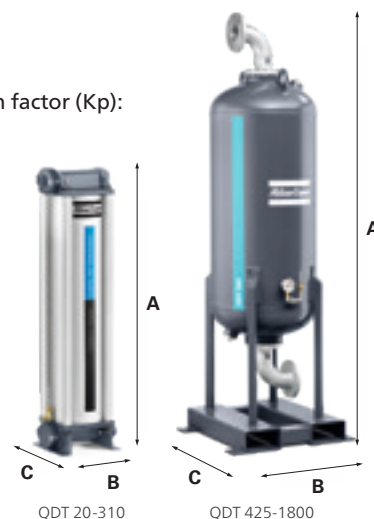

## UD+ & QDT: the winning combination



## CLASS 1: Total oil, according ISO 8573-1:2010

The Atlas Copco UD+ - QDT filter train meets the requirements of air purity class 1 for total oil, according to ISO 8573-1:2010, in a typical compressed air installation.



UD+	QDT
Liquid oil & oil aerosol removal	Oil vapor removal
Guaranteed 0.0009 mg/m <sup>3</sup> aerosol and liquid	Guaranteed 0.003 mg/m <sup>3</sup> vapor
40% pressure drop reduction compared to DD+/PD+	65% pressure drop reduction compared to previous QDT
50% footprint reduction	Extremely compact compared to vessel designs

# QD(+) SERIES

## High performance oil vapor filters

QD(+) filters efficiently reduce hydrocarbons, odors and oil vapor in your compressed air stream to protect your investment, equipment and processes. The activated carbon layers will, by the use of adsorption, reduce the residual oil content to less than 0.003 mg/m<sup>3</sup>. The pressure drop is low and stays minimal during the lifetime of the filter.



## YOUR BENEFITS

### Maximum oil vapor removal

Highly efficient activated carbon layers.

### Significant energy savings & limited system operating costs

Low pressure losses.

### High reliability

High-performance stainless steel cores, double O-rings, epoxy sealed caps, and anti-corrosive coated filter housing.

### Easy maintenance

External ribs on the threaded housing, or a rotating bottom cover for the welded housings, and push-on elements.

## Options

- Filter connection kit for easy mounting in series (10+ - 550+ l/s and 12-690 l/s).
- Wall mounting kit simplifies installation (10+ - 550+ l/s and 12-690 l/s).

For sizing and dimensions, please refer to the product pages of the DD(+) & PD(+) Series.

## Performance

	QD	QD+
Contaminant	Oil vapor	
Test method	ISO 8573-5:2001	
Maximum oil carry-over (mg/m <sup>3</sup> )*	0.003*	
Dry pressure drop (mbar)	190	140
Element service	After 1,000 operating hours or 1 year. Service life is decreased when inlet temperature exceeds 35°C, 95°F	
Precede with	Water separation DD/PD Dryer	Water separation UD+ or DD+/PD+ Dryer

\* After UD+ or DD(+)/PD(+) with inlet oil concentration of 10 mg/m<sup>3</sup>.

# SFA SERIES

## Silicone-free removal of oil aerosol, dust and oil vapor

Superb air purity is a prerequisite to safeguard your instruments and end product. Our silicone-free SFA filters efficiently prevent dry and wet dust, particulates, oil aerosol and water drops from entering your compressed air system. The SFA series is manufactured and treated according to the high standards of silicone-free equipment, and certified by the Fraunhofer Institute as guaranteed silicone-free.



## YOUR BENEFITS

### Maximum contaminant removal

Removal of dry and wet dust, particulates, oil aerosol and water droplets. High-efficiency glass fiber and fleece media.

### Significant energy savings & limited system operating costs

Optimal design and filter media allow for low pressure drops.

### High reliability

High-performance stainless steel cores, double O-rings, epoxy sealed caps and anti-corrosive coated filter housing.

### Easy maintenance

External ribs on the threaded housing and push-on elements.

### Monitoring of energy use

Differential pressure indication (indicator for sizes 9-32 l/s, gauge for sizes 44-520 l/s) (optional).

## Applications

- Painting
- Automotive

## Options

- Filter connection kit (9-520 l/s).
- Wall-mounting kit (9-520 l/s).
- Quick coupling (DD & PD only).
- EWD no-loss electronic drain (DD & PD only).
- Voltage-free contact mounted in the differential gauge (not for QD).

## Certification

Paint compatibility certificate (Fraunhofer Institute)



The performance of the SFA filters is comparable to the performance of the + range filters (please refer to pages 8, 10 and 14).

## Sizing & dimensions

FILTER SIZE	Nominal capacity*		Maximal capacity*		Connections G or NPT	Dimensions						Free space for cartridge replacement		Weight	
	l/s	cfm	l/s	cfm		A		B		C		D		kg	lbs
DD, DDp, PD, PDp, QD	l/s	cfm	l/s	cfm	in	mm	in	mm	in	mm	in	mm	in	kg	lbs
9	9	19	11	23	3/8	90	3.54	61	2.40	268	10.55	75	2.95	1	2.2
17	17	36	21	45	1/2	90	3.54	61	2.40	268	10.55	75	2.95	1.1	2.4
32	32	68	40	85	1/2	90	3.54	61	2.40	323	12.72	75	2.95	1.3	2.9
44	44	93	55	117	3/4 & 1	110	4.33	98.5	3.88	374	14.72	75	2.95	1.9	4.19
60	60	127	75	159	1	110	4.33	98.5	3.88	414	16.3	75	2.95	2.1	4.6
120	120	254	150	318	1-1/2	140	5.51	105	4.13	520	20.47	100	3.94	4.2	9.3
150	150	318	188	399	1-1/2	140	5.51	105	4.13	603	23.47	100	3.94	4.5	9.9
175	175	371	219	464	1-1/2	140	5.51	105	4.13	603	23.47	100	3.94	4.6	10.1
280	280	594	350	742	2 & 2-1/2	179	7.05	121	4.76	689	27.13	150	5.91	6.9	15.2
390	390	827	488	1035	3	210	8.27	128	5.04	791	31.14	200	7.87	11	24.2
520	520	1102	650	1378	3	210	8.27	128	5.04	961	37.83	200	7.87	12.6	27.8

\* Nominal pressure: 7 bar(e)/102 psig; temperature: 20°C, 68°F.



# H SERIES

## Guaranteed air purity up to 350 bar

High pressure filters efficiently reduce oil aerosol, dust and wet dust, particulates, water droplets and oil vapor in your compressed air stream to protect your investment, equipment and processes. Our innovative high pressure filtration solutions are engineered to cost effectively provide the best air purity and meet today's increasing quality demands up to working pressures of 350 bar. All high pressure filter housings are hydraulically tested to ensure safe and reliable operation at all times. A pressure test certificate accompanies each filter.



## YOUR BENEFITS

### Maximum contaminant removal (dry & wet dust, particulates, oil aerosol and water droplets)

High-efficient glass fiber and fleece media.

### Significant energy savings & limited system operation cost

Optimal design and filter media allow for low pressure losses.

### High reliability

High-performance stainless steel cores, double O-rings, epoxy sealed caps and anti-corrosive coated filter housing.

## Applications

- Chemical
- Food & beverage
- Manufacturing
- Military
- Oil & gas

## Performance

	DDHp+	PDHp+	DDH+	PDH+	QDH+
Contaminant	Dry dust		Oil aerosol/wet dust		Oil vapor
Test method	ISO 8573-4:2001 ISO 12500-3:2009		ISO 8573-2:2007 ISO 12500-1:2007		ISO 8573-5:2001
Maximum oil carry-over (mg/m <sup>3</sup> )	-	-	0.08*	0.007*	0.003**
Particle removal efficiency (% at MPPS)	99.92 (0.1)	99.98 (0.06)	N/A	N/A	N/A
Dry pressure drop (mbar)	85	100	N/A	N/A	140
Wet pressure drop (mbar)	N/A	N/A	180	215	N/A
Element service	After 4,000 operating hours or 1 year or 350 mbar pressure drop		After 4,000 operating hours or 1 year		After 1,000 operating hours or 1 year
Precede with	N/A	DDHp+	N/A	DDH+	DDH+/PDH+

Always install a liquid water separation system in front of a filter. Water separation is not needed in the high pressure line if there is a sufficiently low PDP in the low pressure line (e.g. nitrogen skid, low pressure line with adsorption dryer).

\* Inlet oil concentration = 10 mg/m<sup>3</sup>. Oil = oil aerosol and liquid.

\*\* After DD(+)/PD(+) with inlet oil concentration of 10 mg/m<sup>3</sup>.

## Sizing & dimensions

FILTER SIZE	Nominal capacity			Connections	Dimensions						Weight	
					A		B		C			
DDH, DDHp, PDH, PDHp, QDH	m³/h	l/s	cfm	in	mm	in	mm	in	mm	in	kg	lbs
<b>20 bar Aluminum</b>												
15+	54	15	32	3/8	90	3.5	61	2.4	268	10.6	1.0	2.2
32+	115	32	68	1/2	90	3.5	61	2.4	268	10.6	1.1	2.4
55+	198	55	117	1/2	90	3.5	61	2.4	323	12.7	1.3	2.9
80+	288	80	170	3/4 & 1	110	4.3	99	3.9	374	14.7	1.6	3.5
110+	396	110	233	1	110	4.3	99	3.9	414	16.3	2.1	4.6
200+	720	200	424	1 1/2	140	5.5	105	4.1	520	20.5	4.2	9.3
270+	972	270	572	1 1/2	140	5.5	105	4.1	603	23.7	4.5	9.9
330+	1188	330	699	1 1/2	140	5.5	105	4.1	603	23.7	4.6	10.1
490+	1764	490	1038	2 & 2 1/2	179	7.0	121	4.8	689	27.1	6.9	15.2
<b>50 bar Aluminum</b>												
160+	160	44	94	1/4	63	2.5	63	2.5	150	5.9	0.3	0.7
250+	250	69	147	3/8	63	2.5	63	2.5	190	7.4	0.3	0.7
450+	450	125	265	1/2	114	4.4	114	4.4	305	11.9	2.6	5.7
550+	550	153	324	3/4	114	4.4	114	4.4	305	11.9	2.6	5.7
835+	835	232	491	1	114	4.4	114	4.4	395	15.4	3.3	7.3
1250+	1250	347	736	1 1/2	146	5.7	146	5.7	435	17.0	7.5	16.5
1725+	1725	479	1015	1 1/2	146	5.7	146	5.7	435	17.0	7.5	16.5
1925+	1925	535	1133	2	146	5.7	146	5.7	435	17.0	7.5	16.5
3200+	3200	889	1883	2	146	5.7	146	5.7	635	24.8	10	22.0
<b>50 bar Stainless Steel</b>												
100+	100	28	59	1/4	85	3.3	85	3.3	202	7.9	1.7	3.7
200+	200	56	118	3/8	85	3.3	85	3.3	227	8.9	2	4.4
340+	340	94	200	1/2	85	3.3	85	3.3	257	10.0	2.2	4.8
500+	500	139	294	3/4	110	4.3	110	4.3	270	10.5	4	8.8
1000+	1000	278	589	1	110	4.3	110	4.3	422	16.5	5	11.0
1700+	1700	472	1000	1 1/2	150	5.9	150	5.9	517	20.2	15	33.1
2040+	2040	567	1200	2	150	5.9	150	5.9	517	20.2	15	33.1
3400+	3400	944	2000	2	150	5.9	150	5.9	817	31.9	21	46.3
<b>100 bar Stainless Steel</b>												
100+	100	28	59	1/4	65	2.5	65	2.5	135	5.3	3.2	7.1
315+	315	88	185	1/2	65	2.5	65	2.5	250	9.8	5.6	12.3
460+	460	128	271	3/4	88	3.4	88	3.4	275	10.7	6.1	13.4
680+	680	189	400	1	135	5.3	135	5.3	265	10.3	10.5	23.1
1200+	1200	333	706	1	135	5.3	135	5.3	480	18.7	14.7	32.4
1700+	1700	472	1000	1 1/2	150	5.9	150	5.9	525	20.5	22	48.5
3400+	3400	944	2000	2	150	5.9	150	5.9	815	31.8	28	61.7
<b>350 bar Stainless Steel</b>												
48+	48	13	28	1/4	41	1.6	41	1.6	103	4.0	1.6	3.5
111+	111	31	65	1/4	65	2.5	65	2.5	135	5.3	3.2	7.1
255+	255	71	150	1/2	88.5	3.5	88.5	3.5	210	8.2	5.6	12.3
510+	510	142	300	3/4	88.5	3.5	88.5	3.5	280	10.9	6.1	13.4
750+	750	208	441	1	150	5.9	150	5.9	330	12.9	14.5	32.0
1330+	1330	369	783	1	150	5.9	150	5.9	480	18.7	17.4	38.3

## Correction factors

<b>20 bar Aluminum</b>										
Operating pressure	barg	-	-	-	-	-	14	16	18	20
	psig	-	-	-	-	-	203	232	261	290
Correction factor							0.9	0.95	1	1.05
<b>50 bar Aluminum &amp; Stainless Steel</b>										
Operating pressure	barg	4	6	8	10	15	20	30	40	50
	psig	58	87	116	145	218	290	435	581	726
Correction factor		0.14	0.22	0.28	0.34	0.47	0.56	0.7	0.85	1
<b>100 bar Stainless Steel</b>										
Operating pressure	barg	20	30	40	50	60	70	80	90	100
	psig	290	435	581	726	871	1016	1161	1306	1451
Correction factor		0.45	0.57	0.68	0.8	0.84	0.88	0.92	0.96	1
<b>350 bar Stainless Steel</b>										
Operating pressure	barg	-	-	50	100	150	200	250	300	350
	psig	-	-	726	1451	2177	2903	3628	4354	5080
Correction factor				0.73	0.78	0.82	0.87	0.91	0.96	1



### Example

- Working pressure 300 bar(g), compressed air flow 500 m³/h.
- Multiply the nominal capacity of the selected filter with the corresponding correction factor at the required working pressure to obtain the capacity at working pressure:
  - Size 510+: 510 m³/h \* 0.96 = 490 m³/h => the 510+ filter size is not large enough.
  - Size 750+: 750 m³/h \* 0.96 = 720 m³/h => the 750+ filter size is the size to select.



# MV SERIES

## Medical vacuum filters for optimal protection of man and machine

Medical vacuum filters are installed at the inlet of the vacuum pump to remove any liquid, solid or bacterial contamination which could damage the vacuum pump and biologically infect the downstream air. Our innovative medical vacuum filtration solutions comply with HTM medical standards.



## YOUR BENEFITS

### Maximum contaminant removal

Removal of dry and wet dust, particulates, oil aerosol and water droplets. High-efficiency glass fiber and fleece media.

### Significant energy savings & limited system operation cost

Optimal design and filter media allow for low pressure losses.

### High reliability

High performance stainless steel cores, double O-rings, epoxy sealed caps and anti-corrosive coated filter housing.

### Easy maintenance

External ribs on the threaded housing and push-on elements.

### Monitoring of energy use

Differential pressure indication show the pressure loss.

## Applications

- Medical
- Dental
- Veterinary

## Performance

	MV
Contaminant	Dry dust
Maximum temperature	60°C/140°F
Maximum working vacuum	Full vacuum
Test method	Sodium flame test BS 3928:1969, based on requirements of HTM2022
Particle removal efficiency (%)*	99.995
Dry pressure drop (mbar)	30
Element service	After 2,000 operating hours or 1 year or 100 mbar pressure drop

\* In accordance with BS 3928-1969.



## Sizing & dimensions

FILTER SIZE MV	Nominal Capacity	Connections	Dimensions						Weight	
			A		B		C			
			l/min	in	mm	in	mm	in	mm	in
10	400	1/2	60	2	90	4	240	9	1.3	2.9
20	800	1	76	3	110	4	300	12	2.1	4.6
60	2400	1 1/2	103	4	140	5	489	19	4.6	10.1
80	3400	2	135	5	179	7	575	22	6.9	15.2
120	4900	3	155	6	210	8	677	26	11.0	24.2
160	6700	3	155	6	210	8	847	33	12.6	27.8

## Correction factors

Operating pressure	bar(a)	0.1	0.2	0.3	0.4	0.5	0.6	0.7	0.8	0.9	1
	Psig	1	3	4	6	7	9	10	12	13	15
	Torr = mm Hg	75	150	225	300	375	450	525	600	675	750
Correction factor		0.1	0.2	0.3	0.4	0.5	0.6	0.7	0.8	0.9	1

### Example

- Working vacuum 300 mbar(a), capacity 1,000 l/min.
- Multiply the nominal capacity of the selected filter with the corresponding correction factor at the required working vacuum to obtain the correct capacity:
  - Size 60: 2,400 l/min \* 0.3 = 720 l/min => the 60 filter size is not large enough.
  - Size 80: 3,400 l/min \* 0.3 = 1,020 l/min => the 80 filter size is the size to select.



## Options

- Wall mounting kit.
- Drain flask.



Drain flask



## Certification

BS 3928 Sodium flame test certificate based on requirements of HTM2022.



Atlas Copco

atlascopco.com

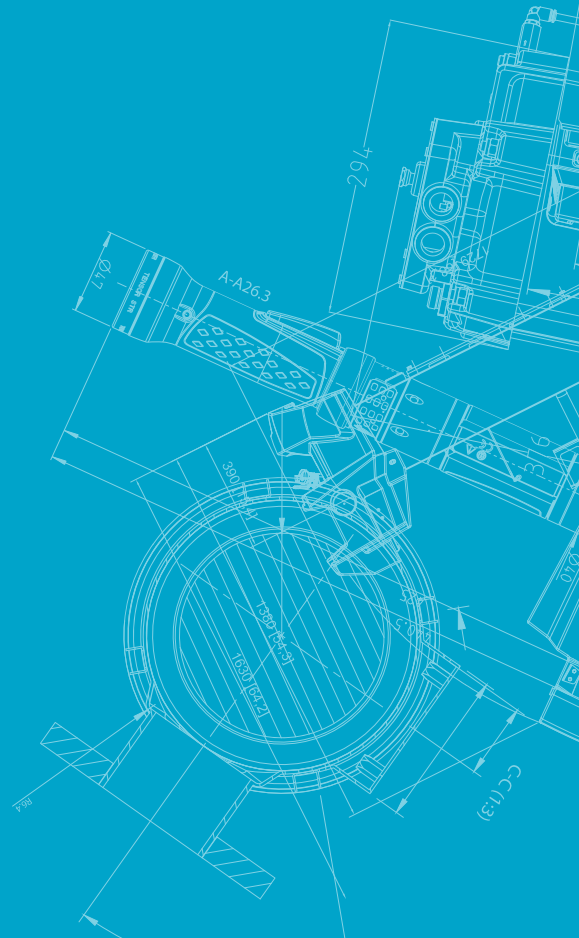

2935 0932 44 © 2018. Atlas Copco Airpower NV, Belgium. All rights reserved. Designs and specifications are subject to change without notice or obligation. Read all safety instructions in the manual before usage.

Atlas Copco

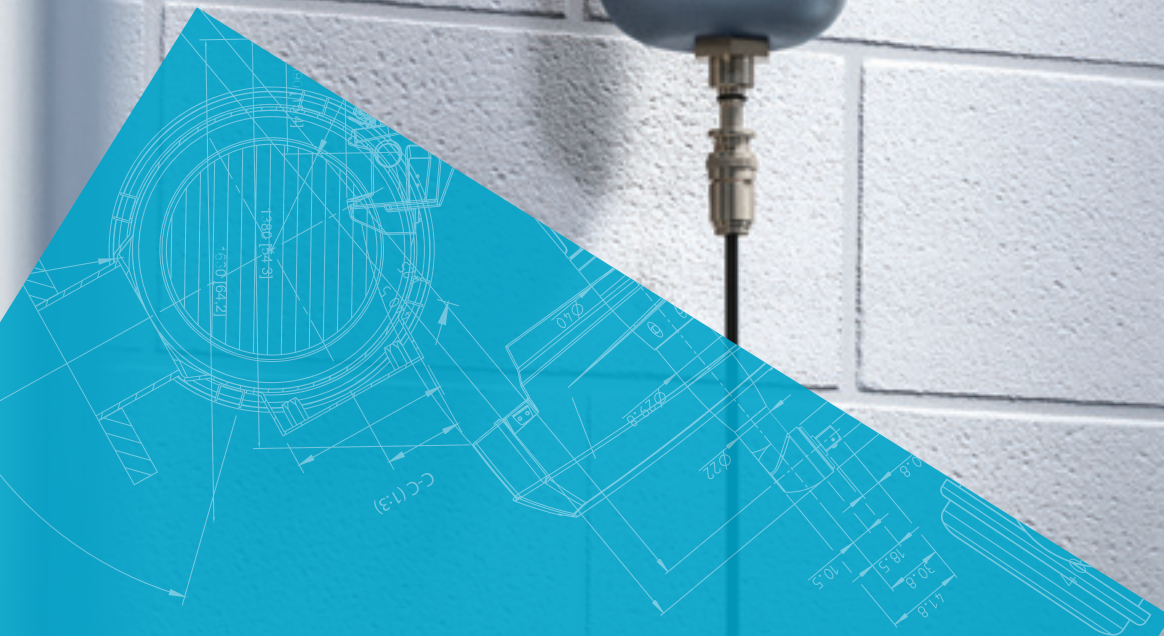

Compressed air filters





## COMMITTED TO SUPERIOR PRODUCTIVITY

### **In-house development & testing**

Since 1998, our dedicated filtration team is responsible for in-house development of cutting-edge filtration solutions. This results in expert know-how of filtration mechanisms, state-of-the-art test facilities and breakthrough innovations. For many years, our filtration team has cooperated closely with the University of Karlsruhe, a leading institute in research of filtration mechanisms.

### **Rigorous quality control**

To ensure the highest standards, all Atlas Copco products are subjected to rigorous quality control testing. The entire filter range is produced in-house, on the most advanced production lines, using the most stringent methods in the industry. You can rest assured at all times that strict certification and testing procedures are conducted to ensure our filtration products meet the highest standards.

# THE ATLAS COPCO SOLUTION

Compressed air can be contaminated by dirt, water and oil, which can be further divided as follows:

- **DIRT:** micro-organisms, dust, solid particles, rust particles.
- **WATER:** water vapor, condensed liquid water, water aerosols, acidic condensates.
- **OIL:** liquid oil, oil aerosol, hydrocarbon vapor.

Atlas Copco offers a wide selection of filtration solutions and application knowledge. Different product types and grades are available to meet your every demand. Only genuine spare cartridges guarantee the Atlas Copco filter performance.



## Welded design

6 grades  
12 sizes  
550 → 8,000 l/s  
1,200 → 17,000 cfm

## Tower design

1 grade  
14 sizes  
20 → 1800 l/s  
42 → 3814 cfm

20 bar / 290 psi  
50 bar / 725 psi  
100 bar / 1,450 psi  
350 bar / 5,075 psi

## Threaded design

5 grades  
9 sizes  
15 → 944 l/s  
32 → 2,000 cfm

## Threaded design

5 grades  
11 sizes  
9 → 520 l/s  
19 → 1,102 cfm

## Threaded design

1grade  
10 sizes  
400 → 6,700 l/min  
14 → 237 cfm



## Cast design

6 grades  
13 sizes  
9 → 550 l/s  
19 → 1,200 cfm



850 → 1,100 l/s  
1,801 → 2,331 cfm



Name	DDp+	PDp+	DD+	PD+	UD+	QD+	QDT	H High pressure		SFA Silicone-free			MV Medical vacuum	
	DDp	PDp	DD	PD		QD		Rough & Fine		Rough & Fine		Basic		Fine
Grade	Rough	Fine	Rough	Fine	Ultimate	Basic	Optimal	Rough & Fine	Rough & Fine	Basic	Rough & Fine	Rough & Fine	Basic	Fine
Contaminant	Dry dust		Oil aerosol / wet dust			Oil vapor		Rough & Fine	Rough & Fine	Basic	Rough & Fine	Rough & Fine	Basic	Dry dust
General applications								Special applications						



Dry dust



Micro-organisms



Oil aerosol



Wet dust



Oil vapor



Water drops

# CERTIFIED PERFORMANCE

Atlas Copco filters are qualified according to the ISO 8573-1:2010 standard. This is the latest edition of the standard. Beware of filters that comply with earlier editions, such as ISO 8573-1:1991 or ISO 8573-1:2001. The difference is inferior quality of the delivered compressed air. This qualification is a result of our filters being tested according to ISO 12500-1:2007, ISO 12500-2:2007, and ISO 12500-3:2009. These specify the test layout, test procedures and inlet conditions required for testing coalescing filters, vapor filters, and solid particle filters used in compressed air systems, to determine their effectiveness in removing oil aerosol, oil vapor and solid particles. The measurements of the air purity downstream the filter for each specific contaminant have been performed according to the test methods described in respectively ISO 8573-2:2007, ISO 8573-5:2001 and ISO 8573-4:2001. Tests have been conducted in-house as well as in external labs, and are independently validated by TÜV.

## ISO certification

Atlas Copco's filters have been fully tested and qualified according to the following ISO standards:

- ISO 8573-1:2010: Compressed air - Contaminants and purity classes
- ISO 8573-2:2007: Compressed air - Test method for oil aerosol content
- ISO 8573-4:2001: Compressed air - Test method for dust
- ISO 8573-5: 2001: Compressed air - Test method for oil vapor and organic solvent content
- ISO 12500-1:2007: Filters for compressed air - test methods - oil aerosols
- ISO 12500-2:2007: Filters for compressed air - test methods - oil vapors
- ISO 12500-3:2009: Filters for compressed air - test methods - particulates



## Certified peace of mind

<b>FILTER APPROVALS</b>	<b>COMPANY CERTIFICATION</b>
CE ASME CRN	® ® ®
<b>ACTIVE MEMBER OF</b>	
pneurop CAGI bcas VDMA	

# A SOLUTION FOR EVERY APPLICATION

At different points of use, different compressed air purities might be needed, depending on the application. The various air purity classes are provided in the table below, which clearly shows the various Atlas Copco filters and dryers that meet all the different classes.

ISO 8573-1:2010 CLASS	Solid particles		Water	Oil (= aerosol, liquid, vapor)
	Wet conditions	Dry conditions		
0	As specified by the customer*			Oil-free compressor
1	DD+ & PD+	DDp+ & PDp+	Desiccant dryer	DD+ & PD+ & QD+/QDT
	UD+			UD+ & QD+/QDT
2	DD+	DDp+	Desiccant dryer	DD+ & PD+ UD+
3	DD+	DDp+	Desiccant dryer, membrane dryer, rotary drum dryer	DD+
4	DD+	DDp+	Membrane dryer, refrigerant dryer	DD+
5	DD+	DDp+	Membrane dryer, refrigerant dryer	-
6	-	-	Membrane dryer, refrigerant dryer	-

\* Please contact your Atlas Copco sales representative.

## Examples of typical installations

<b>A</b>	Compressor - UD+	Air purity class ISO 8573-1:2010 [1:-:2]
<b>B</b>	Compressor - UD+ - Refrigerant dryer	Air purity class ISO 8573-1:2010 [1:4:2]*
<b>C</b>	Compressor - UD+ - Refrigerant dryer - QDT - DDp+	Air purity class ISO 8573-1:2010 [2:4:1]
<b>D</b>	Compressor - UD+ - Desiccant dryer - DDp+	Air purity class ISO 8573-1:2010 [2:2:2]
<b>E</b>	Compressor - UD+ - Desiccant dryer - QDT - DDp+ - PDp+	Air purity class ISO 8573-1:2010 [1:2:1]

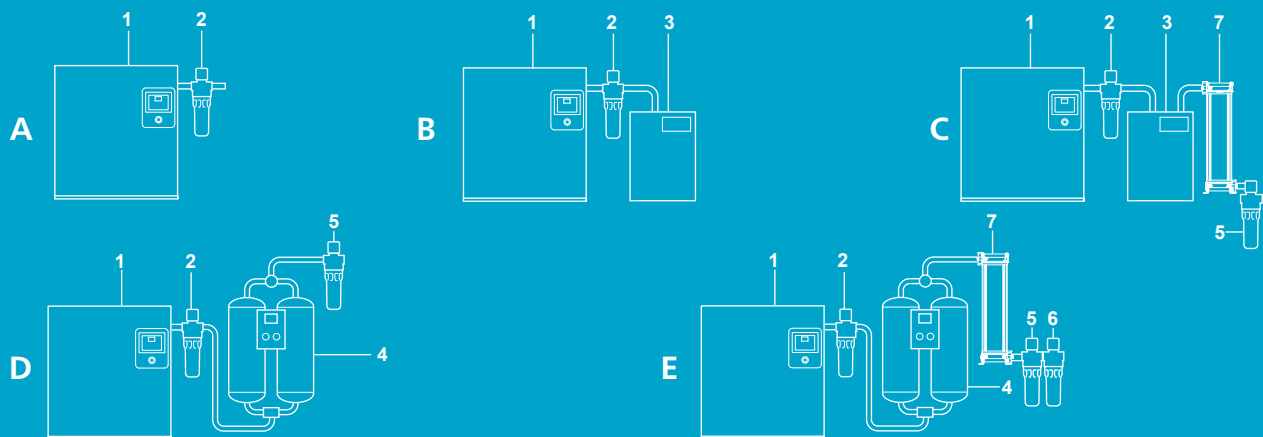

1. Compressor  
2. UD+ filter

3. Refrigerant dryer  
4. Desiccant dryer

5. DDp+ filter  
6. PDp+ filter

7. QDT filter

\* Particle class 1 is reached directly after UD+. As downstream piping & vessels can add particles, it is advised to install particle filters DDp+ and PDp+ just before the application to reach particle class 1 at point of use.

The compressor should be equipped with a liquid water separation system such as an after cooler including a drain or a water separator (WSD). Always install a water separator in front of a coalescence filter. In case of critical applications, install extra air treatment products at point of use for the removal of pipeline contamination and condensation.

# UD+ SERIES

## Two-in-one oil coalescing filters with supreme energy savings

UD+ filters efficiently reduce oil aerosol, wet dust and water drops in your compressed air stream to protect your investment, equipment and processes. The UD+ combines two filtration steps (DD+ and PD+) into one, a unique technology to meet the high-quality requirements of diverse applications and provide ultimate energy savings.



## YOUR BENEFITS

### 40% energy savings

A 40% lower pressure drop than the conventional filter combination results in 40% higher energy efficiency.

### Pure air

Air purity is equal to that obtained using two filters in line, thanks to the thick filter package of UD+ filters.

### Save space

The two-in-one filtration concept reduces installation space and complexity, making UD+ filters particularly suitable for applications where space is at a premium.

### Save money

Install UD+ filters to enjoy significant cost savings compared to conventional filters.

## Performance

	UD+
Contaminant	Oil aerosol/wet dust
Test method	ISO 8573-2:2007, ISO 12500-1:2007
Maximum oil carry-over (mg/m <sup>3</sup> )*	0.0009
Wet pressure drop (mbar)	245
Element service	After 4,000 operating hours or 1 year
Precede with	Water separation

\* Inlet oil concentration = 10 mg/m<sup>3</sup>. Oil = oil aerosol and liquid.



## Sizing & dimensions

FILTER SIZE UD+	Nominal capacity		Reference pressure		Maximum pressure		Connections	Dimensions						Free space for cartridge replacement		Weight	
								A		B		C		D			
	l/s	cfm	bar(e)	psig	bar(e)	psig	in	mm	in	mm	in	mm	in	mm	in	kg	lbs
9+	9	19	7	102	16	232	3/8	90	3.5	61	2.4	268	10.6	75	2.9	1.0	2.2
15+	15	32	7	102	16	232	1/2	90	3.5	61	2.4	268	10.6	75	2.9	1.1	2.4
25+	25	53	7	102	16	232	1/2	90	3.5	61	2.4	323	12.8	75	2.9	1.3	2.9
45+	45	95	7	102	16	232	3/4 & 1	110	4.3	99	3.9	374	14.7	75	2.9	1.6	4.2
60+	60	127	7	102	16	232	1	110	4.3	99	3.9	414	16.3	75	2.9	2.1	4.6
100+	100	212	7	102	16	232	1	140	5.5	105	4.0	425	16.7	100	3.9	3.7	8.2
140+	140	297	7	102	16	232	1-1/2	140	5.5	105	4.1	520	20.5	100	3.9	4.2	9.3
180+	180	381	7	102	16	232	1-1/2	140	5.5	105	4.1	603	23.7	100	3.9	4.5	9.9
220+	220	466	7	102	16	232	1-1/2	140	5.5	105	4.1	603	23.7	100	3.9	4.6	10.1
310+	310	657	7	102	16	232	2 & 2-1/2	179	7.1	121	4.8	689	27.1	150	5.9	6.9	15.2
425+	425	901	7	102	16	232	3	210	8.3	128	5.1	791	31.1	200	7.9	11.0	24.2
550+	550	1165	7	102	16	232	3	210	8.3	128	5.1	961	37.8	200	7.9	12.6	27.8
550+F	550	1165	7	102	16	232	DN80	370	14.6	280	11.0	1295	51.0	1375	54.1	76.0	167.6
850+T	850	1.801	7	102	16	232	DN100	510	20.1	418	16.5	796	31.3	200	7.9	35.2	77.6
850+F	850	1801	7	102	16	232	DN100	510	20.1	410	16.1	1360	53.5	1500	59.1	141.0	310.9
1100+T	1.100	2.331	7	102	16	232	DN100	510	20.1	418	16.5	966	38.0	200	7.9	37.4	82.4
1100+F	1100	2331	7	102	16	232	DN100	510	20.1	410	16.1	1360	53.5	1500	59.1	143.0	315.3
1400+F	1400	2967	7	102	16	232	DN150	620	24.4	485	19.1	1480	58.3	1560	61.4	210.0	463.0
1800+F	1800	3814	7	102	16	232	DN150	640	25.2	490	19.3	1555	61.2	1640	64.6	176.0	388.0
2200+F	2200	4662	7	102	16	232	DN150	640	25.2	490	19.3	1555	61.2	1640	64.6	178.0	392.4
3000+F	3000	6357	7	102	16	232	DN200	820	32.3	650	17.7	1745	68.7	1710	67.3	420.0	925.9
4000+F	4000	8476	7	102	16	232	DN200	820	32.3	650	17.7	1745	68.7	1710	67.3	428.0	943.6
5000+F	5000	10595	7	102	16	232	DN200	820	32.3	650	17.7	1745	68.7	1710	67.3	432.0	952.4
6000+F	6000	12714	7	102	16	232	DN250	920	36.2	815	32.1	2085	82.1	1625	64.0	671.0	1479.3
7000+F	7000	14833	7	102	16	232	DN250	920	36.2	815	32.1	2085	82.1	1625	64.0	675.0	1488.1
8000+F	8000	16952	7	102	16	232	DN300	1040	40.9	930	36.6	2070	81.5	1625	64.0	900.0	1984.2

## Correction factors

Inlet pressure (bar)	1	2	3	4	5	6	7	8	10	12	14	16
Inlet pressure (psig)	15	29	44	58	72.5	87	102	116	145	174	203	232
Correction factor	0.38	0.53	0.65	0.75	0.83	0.92	1.00	1.06	1.20	1.31	1.41	1.50

### Example

- Working pressure 3 bar(g), compressed air flow 35 l/s.
- Multiply the nominal capacity of the selected filter with the corresponding correction factor at the required working pressure to obtain the capacity at working pressure:
  - Size 45+: 45 l/s \* 0.65 = 29 l/s => the 45+ filter size is not large enough.
  - Size 60+: 60 l/s \* 0.65 = 39 l/s => the 60+ filter size is the size to select.

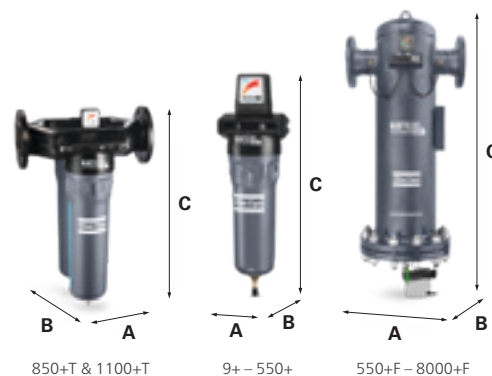

## Options

- Filter connection kit for easy mounting in series (9-550 l/s).
- Wall mounting kit simplifies installation (9-550 l/s).
- Quick coupling connects the filter with a drain or oil/water separator.
- Voltage-free contact mounted in the differential pressure gauge, to give remote indication of cartridge replacement.
- EWD electronic drain with no loss of compressed air and an alarm function (EWD is optional on size 9+ - 550+, 850+T and 1100+T; standard on size 550+F and larger).

## Certification

- ISO 8573-2:2007
- ISO 12500-1:2007



# DD(+)/PD(+) SERIES

## High performance oil coalescing filters

DD(+) and PD(+) filters efficiently reduce oil aerosol, wet dust and water drops in your compressed air stream. These could come from the lubrication of the compressor element, the intake air, and the compressor installation itself. These innovative filtration solutions are engineered to cost-effectively provide the best air purity and meet today's increasing quality demands.



## YOUR BENEFITS

### Maximum oil aerosol, wet dust and water droplet filtration and drainage

High-efficient glass fiber and foam media.

### Significant energy savings & limited system operating costs

Optimal design and filter media allow low pressure losses.

### High reliability

High-performance stainless steel cores, double O-rings, epoxy sealed caps, and anti-corrosive coated filter housing.

### Easy maintenance

External ribs on the threaded housing, or a rotating bottom cover for the welded housings, and push-on elements.

### Monitoring of energy use

Differential pressure indication (indicator for sizes 10-35 l/s, gauge for sizes 50-8000 l/s) (optional for standard range).

## Performance

	DD	PD	DD+	PD+
Contaminant	Oil aerosol/wet dust			
Test method	ISO 8573-2:2007, ISO 12500-1:2007			
Maximum oil carry-over (mg/m <sup>3</sup> )*	0.1*	0.01*	0.07*	0.008*
Wet pressure drop (mbar)	245	280	180	215
Element service	After 4,000 operating hours or 1 year			
Precede with	Water separation	Water separation DD	Water separation	Water separation DD+

\* Inlet oil concentration = 10 mg/m<sup>3</sup>. Oil = oil aerosol and liquid.

## Sizing & dimensions

FILTER SIZE DD/PD		Nominal capacity				Reference pressure		Maximum pressure		Connections	Dimensions						Free space for cartridge replacement		Weight	
		Standard		+							A		B		C		D			
Standard	+	l/s	cfm	l/s	cfm	bar(e)	psig	bar(e)	psig	in	mm	in	mm	in	mm	in	mm	in	kg	lbs
12	10+	12	25	10	21	7	102	16	232	3/8	90	3.5	61	2.4	268	10.6	75	2.9	1.0	2.2
25	20+	25	53	20	42	7	102	16	232	1/2	90	3.5	61	2.4	268	10.6	75	2.9	1.1	2.4
45	35+	45	95	35	74	7	102	16	232	1/2	90	3.5	61	2.4	323	12.7	75	2.9	1.3	2.9
65	50+	65	138	50	106	7	102	16	232	3/4 & 1	110	4.3	99	3.9	374	14.7	75	2.9	1.6	4.2
90	70+	90	191	70	148	7	102	16	232	1	110	4.3	99	3.9	414	16.3	75	2.9	2.1	4.6
160	130+	160	339	130	275	7	102	16	232	1-1/2	140	5.5	105	4.1	520	20.5	100	3.9	4.2	9.3
215	170+	215	456	170	360	7	102	16	232	1-1/2	140	5.5	105	4.1	603	23.7	100	3.9	4.5	9.9
265	210+	265	562	210	445	7	102	16	232	1-1/2	140	5.5	105	4.1	603	23.7	100	3.9	4.6	10.1
360	310+	360	763	310	657	7	102	16	232	2 & 2-1/2	179	7.0	121	4.8	689	27.1	150	5.9	6.9	15.2
525	425+	525	1112	425	901	7	102	16	232	3	210	8.3	128	5.0	791	31.1	200	7.9	11.0	24.2
690	550+	690	1462	550	1165	7	102	16	232	3	210	8.3	128	5.0	961	37.9	200	7.9	12.6	27.8
630F	550+F	630	1335	550	1165	7	102	16	232	DN80	370	14.6	280	11	1295	51.0	1375	54.1	76.0	167.6
-	850+T	-	-	850	1801	7	102	16	232	DN100	510	20.1	418	16.5	796	31.3	200	7.9	35.2	77.6
970F	850+F	970	2055	850	1801	7	102	16	232	DN100	510	20.1	410	16.1	1360	53.5	1500	59.1	141.0	310.9
-	1100+T	-	-	1100	2331	7	102	16	232	DN100	510	20.1	418	16.5	966	38.0	200	7.9	37.4	82.4
1260F	1100+F	1260	2670	1100	2331	7	102	16	232	DN100	510	20.1	410	16.1	1360	53.5	1500	59.1	143.0	415.3
1600F	1400+F	1600	3390	1400	2967	7	102	16	232	DN150	620	24.4	485	19.1	1480	58.3	1560	61.4	210.0	463.0
2200F	1800+F	2200	4662	1800	3814	7	102	16	232	DN150	640	25.2	490	19.3	1555	61.2	1640	64.6	176.0	388.0
2400F	2200+F	2400	5086	2200	4662	7	102	16	232	DN150	640	25.2	490	19.3	1555	61.2	1640	64.6	178.0	392.4
3600F	3000+F	3600	7628	3000	6357	7	102	16	232	DN200	820	32.3	650	25.6	1745	68.7	1710	67.3	420.0	925.9
-	4000+F	-	-	4000	8476	7	102	16	232	DN200	820	32.3	650	25.6	1745	68.7	1710	67.3	428.0	943.6
-	5000+F	-	-	5000	10595	7	102	16	232	DN200	820	32.3	650	25.6	1745	68.7	1710	67.3	432.0	952.4
-	6000+F	-	-	6000	12714	7	102	16	232	DN250	920	32.3	815	32.1	2085	80.3	1625	64	671.0	1479.3
-	7000+F	-	-	7000	14833	7	102	16	232	DN250	920	36.2	815	32.1	2085	82.1	1625	64	675.0	1488.1
-	8000+F	-	-	8000	16952	7	102	16	232	DN300	1040	40.9	930	36.6	2070	81.5	1625	64	900.0	1984.2

## Correction factors

Inlet pressure (bar)	1	2	3	4	5	6	7	8	10	12	14	16
Inlet pressure (psig)	15	29	44	58	72.5	87	102	116	145	174	203	232
Correction factor	0.38	0.53	0.65	0.75	0.83	0.92	1.00	1.06	1.20	1.31	1.41	1.50

### Example

- Working pressure 3 bar(g), compressed air flow 35 l/s.
- Multiply the nominal capacity of the selected filter with the corresponding correction factor at the required working pressure to obtain the capacity at working pressure:
  - Size 50+: 50 l/s \* 0.65 = 33 l/s => the 50+ filter size is not large enough.
  - Size 70+: 70 l/s \* 0.65 = 46 l/s => the 70+ filter size is the size to select.

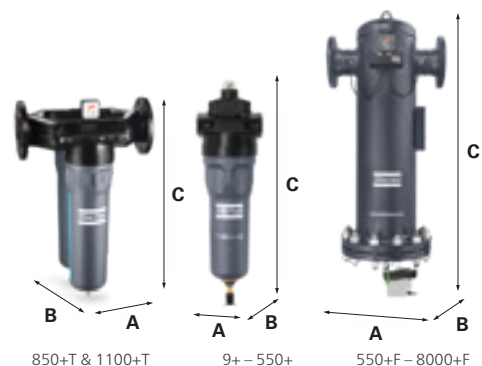

## Options

- Filter connection kit for easy mounting in series (10+ - 550+ l/s and 12-690 l/s).
- Wall-mounting kit simplifies installation (10+ - 550+ l/s and 12-690 l/s).
- Quick coupling connects the filter with a drain or oil/water separator.
- Voltage-free contact mounted in the differential pressure gauge, to give remote indication of cartridge replacement.
- EWD electronic drain with no loss of compressed air and an alarm function (EWD is optional on sizes 10+ - 550+ l/s and 12-690 l/s; standard on sizes ≥550F).

## Certification

- ISO 8573-2:2007
- ISO 12500-1:2007



EWD electronic drain

# DDp(+)/PDp(+) SERIES

## Optimal dry dust filtration

DDp(+) and PDp(+) filters efficiently prevent dust, particulates and micro-organisms arising from corrosion, dirt and adsorption material from entering your compressed air stream. These innovative filtration solutions are engineered to cost-effectively provide the best air purity and meet today's increasing quality demands.



## YOUR BENEFITS

### Maximum dirt, solid particles, micro-organisms and rust particles removal

High-efficient glass fiber and foam media.

### Significant energy savings & limited system operating costs

Optimal design and filter media allow for low pressure losses.

### High reliability

High-performance stainless steel cores, double O-rings, epoxy sealed caps, and anti-corrosive coated filter housing.

### Easy maintenance

External ribs on the threaded housing, or a rotating bottom cover for the welded housings, and push-on elements.

### Monitoring of energy use

Differential pressure indication (indicator for sizes 10-35 l/s, gauge for sizes 45-8000 l/s) (optional for standard range).

## Performance

	DDp	PDp	DDp+	PDp+
Contaminant	Dry dust			
Test method	ISO 8573-4:2001, ISO 12500-3:2009			
Particle removal efficiency (% at MPPS)	99.81	99.97	99.92	99.98
Dry pressure drop (mbar)	135	150	85	100
Element service	After 4,000 operating hours or 1 year or 350 mbar pressure drop			
Precede with	Dryer	Dryer DDp	Dryer	Dryer DDp+

## Sizing & dimensions

FILTER SIZE DDp/PDp		Nominal capacity				Reference pressure		Maximum pressure		Connections	Dimensions						Free space for cartridge replacement		Weight	
		Standard		+							A		B		C		D			
Standard	+	l/s	cfm	l/s	cfm	bar(e)	psig	bar(e)	psig	in	mm	in	mm	in	mm	in	mm	in	kg	lbs
12	10+	12	25	10	21	7	102	16	232	3/8	90	3.5	61	2.4	268	10.6	75	2.9	1.0	2.2
25	20+	25	53	20	42	7	102	16	232	1/2	90	3.5	61	2.4	268	10.6	75	2.9	1.1	2.4
45	35+	45	95	35	74	7	102	16	232	1/2	90	3.5	61	2.4	323	12.7	75	2.9	1.3	2.9
65	50+	65	138	50	106	7	102	16	232	3/4 & 1	110	4.3	99	3.9	374	14.7	75	2.9	1.6	4.2
90	70+	90	191	70	148	7	102	16	232	1	110	4.3	99	3.9	414	16.3	75	2.9	2.1	4.6
160	130+	160	339	130	275	7	102	16	232	1-1/2	140	5.5	105	4.1	520	20.5	100	3.9	4.2	9.3
215	170+	215	456	170	360	7	102	16	232	1-1/2	140	5.5	105	4.1	603	23.7	100	3.9	4.5	9.9
265	210+	265	562	210	445	7	102	16	232	1-1/2	140	5.5	105	4.1	603	23.7	100	3.9	4.6	10.1
360	310+	360	763	310	657	7	102	16	232	2 & 2-1/2	179	7.0	121	4.8	689	27.1	150	5.9	6.9	15.2
525	425+	525	1112	425	901	7	102	16	232	3	210	8.3	128	5.0	791	31.1	200	7.9	11.0	24.2
690	550+	690	1462	550	1165	7	102	16	232	3	210	8.3	128	5.0	961	37.9	200	7.9	12.6	27.8
630F	550+F	630	1335	550	1165	7	102	16	232	DN80	370	14.6	280	11	1295	51.0	1375	54.1	76.0	167.6
-	850+T	-	-	850	1801	7	102	16	232	DN100	510	20.1	418	16.5	796	31.3	200	7.9	35.2	77.6
970F	850+F	970	2055	850	1801	7	102	16	232	DN100	510	20.1	410	16.1	1360	53.5	1500	59.1	141.0	310.9
-	1100+T	-	-	1100	2331	7	102	16	232	DN100	510	20.1	418	16.5	966	38.0	200	7.9	37.4	82.4
1260F	1100+F	1260	2670	1100	2331	7	102	16	232	DN100	510	20.1	410	16.1	1360	53.5	1500	59.1	143.0	415.3
1600F	1400+F	1600	3390	1400	2967	7	102	16	232	DN150	620	24.4	485	19.1	1480	58.3	1560	61.4	210.0	463.0
2200F	1800+F	2200	4662	1800	3814	7	102	16	232	DN150	640	25.2	490	19.3	1555	61.2	1640	64.6	176.0	388.0
2400F	2200+F	2400	5086	2200	4662	7	102	16	232	DN150	640	25.2	490	19.3	1555	61.2	1640	64.6	178.0	392.4
3600F	3000+F	3600	7628	3000	6357	7	102	16	232	DN200	820	32.3	650	25.6	1745	68.7	1710	67.3	420.0	925.9
-	4000+F	-	-	4000	8476	7	102	16	232	DN200	820	32.3	650	25.6	1745	68.7	1710	67.3	428.0	943.6
-	5000+F	-	-	5000	10595	7	102	16	232	DN250	820	32.3	650	25.6	1745	68.7	1710	67.3	432.0	952.4
-	6000+F	-	-	6000	12714	7	102	16	232	DN250	920	32.3	815	32.1	2085	80.3	1625	64	671.0	1479.3
-	7000+F	-	-	7000	14833	7	102	16	232	DN300	920	36.2	815	32.1	2085	82.1	1625	64	675.0	1488.1
-	8000+F	-	-	8000	16952	7	102	16	232	DN300	1040	40.9	930	36.6	2070	81.5	1625	64	900.0	1984.2

## Correction factors

Inlet pressure (bar)	1	2	3	4	5	6	7	8	10	12	14	16
Inlet pressure (psig)	15	29	44	58	72.5	87	102	116	145	174	203	232
Correction factor	0.38	0.53	0.65	0.75	0.83	0.92	1.00	1.06	1.20	1.31	1.41	1.50

### Example

- Working pressure 3 bar(g), compressed air flow 35 l/s.
- Multiply the nominal capacity of the selected filter with the corresponding correction factor at the required working pressure to obtain the capacity at working pressure:
  - Size 50+: 50 l/s \* 0.65 = 33 l/s => the 50+ filter size is not large enough.
  - Size 70+: 70 l/s \* 0.65 = 46 l/s => the 70+ filter size is the size to select.

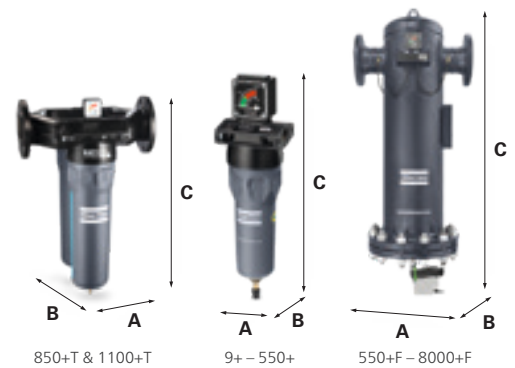

## Options

- Filter connection kit for easy mounting in series (10+ - 550+ l/s and 12-690 l/s).
- Wall-mounting kit simplifies installation (10+ - 550+ l/s and 12-690 l/s).
- Voltage-free contact mounted in the differential pressure gauge, to give remote indication of cartridge replacement.

## Certification

- ISO 8573-4:2001
- ISO 12500-3:2009

Voltage-free contact



# QDT SERIES

## Activated carbon towers for optimal oil vapor filtration

The high efficiency activated carbon tower is capable of removing hydrocarbons, odors and oil vapor from compressed air.

The activated carbon will, by the use of adsorption,

reduce the residual oil content to lower than 0.003 mg/m<sup>3</sup>.

The pressure drop is low and stays minimal during the filter's lifetime.



## YOUR BENEFITS

### Maximum oil vapor removal

Superb activated carbon material.

### Low pressure drop

Optimal internal flow path.

### High reliability

Robust design and optimal filter material.

### Options

- Oil indicator ensures pure air.
- Wall mounting kit for easy installation (20 – 185 l/s).



### Certification

ISO 8573-5:2001

## Performance

	QDT
Contaminant	Oil vapor
Test method	ISO 8573-5:2001, ISO 12500-2:2007
Maximum oil carry-over (mg/m <sup>3</sup> )*	0.003
Dry pressure drop (mbar)	125 (QDT 20-310) 72 (QDT 425-1800)
Element service	After 4,000 operating hours or 1 year
Precede with	Water separation UD+ or DD+/PD+ Dryer

\* After UD+ or DD+/PD+ with inlet oil concentration of 10 mg/m<sup>3</sup>.



## Sizing & dimensions

FILTER SIZE QDT	Nominal capacity		Connections G or NPT threaded	Dimensions						Weight	
				A		B		C			
	l/s	cfm	DIN or ANSI flanged	mm	in	mm	in	mm	in	kg	lbs
20	20	42	1/2"	490	19	223	9	190	7	10	22
45	45	95	1"	715	28	223	9	190	7	15	33
60	60	127	1"	840	33	223	9	190	7	18	40
95	95	210	1"	715	28	387	15	190	7	29	64
125	125	265	1 1/2"	840	33	387	15	190	7	34	75
150	150	318	1 1/2"	715	28	551	22	190	7	42	93
185	185	392	1 1/2"	840	33	551	22	190	7	50	110
245	245	519	1 1/2"	840	33	715	28	190	7	67	148
310	310	657	1 1/2"	840	33	879	35	190	7	84	185
425	425	901	DN80 / 3"	2148	85	710	28	600	24	264	581
550	550	1165	DN80 / 3"	2190	86	710	28	670	26	302	664
850	850	1801	DN100 / 4"	2320	91	724	29	805	32	391	860
1100	1100	2331	DN100 / 4"	2450	97	934	37	820	32	602	1324
1800	1800	3814	DN150 / 6"	2612	103	1046	41	980	39	882	1940

## Correction factors

For other compressed air inlet temperatures, please multiply the filter capacity by the following correction factor (Kt):

Inlet temperature °C	20	25	30	35	40	45	50	55	60
Inlet temperature °F	68	77	96	95	104	113	122	131	140
Correction factor	1	1	1	1	0.85	0.67	0.59	0.48	0.42

For other compressed air inlet pressures, please multiply the filter capacity by the following correction factor (Kp):

Inlet pressure bar	3	4	5	6	7	8	9	10	11	12	13
Inlet pressure psi	44	58	73	87	102	116	131	145	160	174	193
Correction factor	0.57	0.77	0.83	1	1	1	1	1.05	1.05	1.11	1.18

### Example

- Working temperature 50°C, pressure 12 bar(g), compressed air flow 120 l/s.
- Multiply the nominal capacity of the selected filter with the corresponding correction factors at the required working temperature and pressure to obtain the capacity at operating condition
  - QDT 150:  $150\text{l/s} * 0.59 * 1.11 = 98\text{l/s} \Rightarrow$  A QDT 150 filter is not large enough
  - QDT 195:  $195\text{l/s} * 0.59 * 1.11 = 128\text{l/s} \Rightarrow$  A QDT 195 filter is the correct size

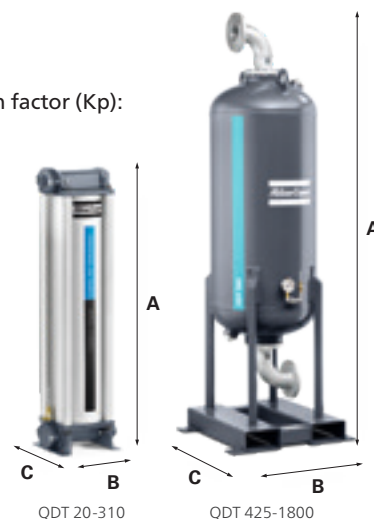

## UD+ & QDT: the winning combination



## CLASS 1: Total oil, according ISO 8573-1:2010

The Atlas Copco UD+ - QDT filter train meets the requirements of air purity class 1 for total oil, according to ISO 8573-1:2010, in a typical compressed air installation.



UD+	QDT
Liquid oil & oil aerosol removal	Oil vapor removal
Guaranteed 0.0009 mg/m <sup>3</sup> aerosol and liquid	Guaranteed 0.003 mg/m <sup>3</sup> vapor
40% pressure drop reduction compared to DD+/PD+	65% pressure drop reduction compared to previous QDT
50% footprint reduction	Extremely compact compared to vessel designs

# QD(+) SERIES

## High performance oil vapor filters

QD(+) filters efficiently reduce hydrocarbons, odors and oil vapor in your compressed air stream to protect your investment, equipment and processes. The activated carbon layers will, by the use of adsorption, reduce the residual oil content to less than 0.003 mg/m<sup>3</sup>. The pressure drop is low and stays minimal during the lifetime of the filter.



## YOUR BENEFITS

### Maximum oil vapor removal

Highly efficient activated carbon layers.

### Significant energy savings & limited system operating costs

Low pressure losses.

### High reliability

High-performance stainless steel cores, double O-rings, epoxy sealed caps, and anti-corrosive coated filter housing.

### Easy maintenance

External ribs on the threaded housing, or a rotating bottom cover for the welded housings, and push-on elements.

### Options

- Filter connection kit for easy mounting in series (10+ - 550+ l/s and 12-690 l/s).
- Wall mounting kit simplifies installation (10+ - 550+ l/s and 12-690 l/s).

For sizing and dimensions, please refer to the product pages of the DD(+) & PD(+) Series.

## Performance

	QD	QD+
Contaminant	Oil vapor	
Test method	ISO 8573-5:2001	
Maximum oil carry-over (mg/m <sup>3</sup> )*	0.003*	
Dry pressure drop (mbar)	190	140
Element service	After 1,000 operating hours or 1 year. Service life is decreased when inlet temperature exceeds 35°C, 95°F	
Precede with	Water separation DD/PD Dryer	Water separation UD+ or DD+/PD+ Dryer

\* After UD+ or DD(+)/PD(+) with inlet oil concentration of 10 mg/m<sup>3</sup>.



# SFA SERIES

## Silicone-free removal of oil aerosol, dust and oil vapor

Superb air purity is a prerequisite to safeguard your instruments and end product. Our silicone-free SFA filters efficiently prevent dry and wet dust, particulates, oil aerosol and water drops from entering your compressed air system. The SFA series is manufactured and treated according to the high standards of silicone-free equipment, and certified by the Fraunhofer Institute as guaranteed silicone-free.



## YOUR BENEFITS

### Maximum contaminant removal

Removal of dry and wet dust, particulates, oil aerosol and water droplets. High-efficiency glass fiber and fleece media.

### Significant energy savings & limited system operating costs

Optimal design and filter media allow for low pressure drops.

### High reliability

High-performance stainless steel cores, double O-rings, epoxy sealed caps and anti-corrosive coated filter housing.

### Easy maintenance

External ribs on the threaded housing and push-on elements.

### Monitoring of energy use

Differential pressure indication (indicator for sizes 9-32 l/s, gauge for sizes 44-520 l/s) (optional).

## Applications

- Painting
- Automotive

## Options

- Filter connection kit (9-520 l/s).
- Wall-mounting kit (9-520 l/s).
- Quick coupling (DD & PD only).
- EWD no-loss electronic drain (DD & PD only).
- Voltage-free contact mounted in the differential gauge (not for QD).

## Certification

Paint compatibility certificate (Fraunhofer Institute)



The performance of the SFA filters is comparable to the performance of the + range filters (please refer to pages 8, 10 and 14).

## Sizing & dimensions

FILTER SIZE	Nominal capacity*		Maximal capacity*		Connections G or NPT	Dimensions						Free space for cartridge replacement		Weight	
	l/s	cfm	l/s	cfm		in	A		B		C		D		kg
DD, DDp, PD, PDp, QD	l/s	cfm	l/s	cfm	in	mm	in	mm	in	mm	in	mm	in	kg	lbs
9	9	19	11	23	3/8	90	3.54	61	2.40	268	10.55	75	2.95	1	2.2
17	17	36	21	45	1/2	90	3.54	61	2.40	268	10.55	75	2.95	1.1	2.4
32	32	68	40	85	1/2	90	3.54	61	2.40	323	12.72	75	2.95	1.3	2.9
44	44	93	55	117	3/4 & 1	110	4.33	98.5	3.88	374	14.72	75	2.95	1.9	4.19
60	60	127	75	159	1	110	4.33	98.5	3.88	414	16.3	75	2.95	2.1	4.6
120	120	254	150	318	1-1/2	140	5.51	105	4.13	520	20.47	100	3.94	4.2	9.3
150	150	318	188	399	1-1/2	140	5.51	105	4.13	603	23.47	100	3.94	4.5	9.9
175	175	371	219	464	1-1/2	140	5.51	105	4.13	603	23.47	100	3.94	4.6	10.1
280	280	594	350	742	2 & 2-1/2	179	7.05	121	4.76	689	27.13	150	5.91	6.9	15.2
390	390	827	488	1035	3	210	8.27	128	5.04	791	31.14	200	7.87	11	24.2
520	520	1102	650	1378	3	210	8.27	128	5.04	961	37.83	200	7.87	12.6	27.8

\* Nominal pressure: 7 bar(e)/102 psig; temperature: 20°C, 68°F.



# H SERIES

## Guaranteed air purity up to 350 bar

High pressure filters efficiently reduce oil aerosol, dust and wet dust, particulates, water droplets and oil vapor in your compressed air stream to protect your investment, equipment and processes. Our innovative high pressure filtration solutions are engineered to cost effectively provide the best air purity and meet today's increasing quality demands up to working pressures of 350 bar. All high pressure filter housings are hydraulically tested to ensure safe and reliable operation at all times. A pressure test certificate accompanies each filter.



## YOUR BENEFITS

### Maximum contaminant removal (dry & wet dust, particulates, oil aerosol and water droplets)

High-efficient glass fiber and fleece media.

### Significant energy savings & limited system operation cost

Optimal design and filter media allow for low pressure losses.

### High reliability

High-performance stainless steel cores, double O-rings, epoxy sealed caps and anti-corrosive coated filter housing.

### Applications

- Chemical
- Food & beverage
- Manufacturing
- Military
- Oil & gas

## Performance

	DDHp+	PDHp+	DDH+	PDH+	QDH+
Contaminant	Dry dust		Oil aerosol/wet dust		Oil vapor
Test method	ISO 8573-4:2001 ISO 12500-3:2009		ISO 8573-2:2007 ISO 12500-1:2007		ISO 8573-5:2001
Maximum oil carry-over (mg/m <sup>3</sup> )	-	-	0.08*	0.007*	0.003**
Particle removal efficiency (% at MPPS)	99.92 (0.1)	99.98 (0.06)	N/A	N/A	N/A
Dry pressure drop (mbar)	85	100	N/A	N/A	140
Wet pressure drop (mbar)	N/A	N/A	180	215	N/A
Element service	After 4,000 operating hours or 1 year or 350 mbar pressure drop		After 4,000 operating hours or 1 year		After 1,000 operating hours or 1 year
Precede with	N/A	DDHp+	N/A	DDH+	DDH+/PDH+

Always install a liquid water separation system in front of a filter. Water separation is not needed in the high pressure line if there is a sufficiently low PDP in the low pressure line (e.g. nitrogen skid, low pressure line with adsorption dryer).

\* Inlet oil concentration = 10 mg/m<sup>3</sup>. Oil = oil aerosol and liquid.

\*\* After DD(+)/PD(+) with inlet oil concentration of 10 mg/m<sup>3</sup>.

## Sizing & dimensions

FILTER SIZE	Nominal capacity			Connections	Dimensions						Weight	
					A		B		C			
DDH, DDHp, PDH, PDHp, QDH	m³/h	l/s	cfm	in	mm	in	mm	in	mm	in	kg	lbs
<b>20 bar Aluminum</b>												
15+	54	15	32	3/8	90	3.5	61	2.4	268	10.6	1.0	2.2
32+	115	32	68	1/2	90	3.5	61	2.4	268	10.6	1.1	2.4
55+	198	55	117	1/2	90	3.5	61	2.4	323	12.7	1.3	2.9
80+	288	80	170	3/4 & 1	110	4.3	99	3.9	374	14.7	1.6	3.5
110+	396	110	233	1	110	4.3	99	3.9	414	16.3	2.1	4.6
200+	720	200	424	1 1/2	140	5.5	105	4.1	520	20.5	4.2	9.3
270+	972	270	572	1 1/2	140	5.5	105	4.1	603	23.7	4.5	9.9
330+	1188	330	699	1 1/2	140	5.5	105	4.1	603	23.7	4.6	10.1
490+	1764	490	1038	2 & 2 1/2	179	7.0	121	4.8	689	27.1	6.9	15.2
<b>50 bar Aluminum</b>												
160+	160	44	94	1/4	63	2.5	63	2.5	150	5.9	0.3	0.7
250+	250	69	147	3/8	63	2.5	63	2.5	190	7.4	0.3	0.7
450+	450	125	265	1/2	114	4.4	114	4.4	305	11.9	2.6	5.7
550+	550	153	324	3/4	114	4.4	114	4.4	305	11.9	2.6	5.7
835+	835	232	491	1	114	4.4	114	4.4	395	15.4	3.3	7.3
1250+	1250	347	736	1 1/2	146	5.7	146	5.7	435	17.0	7.5	16.5
1725+	1725	479	1015	1 1/2	146	5.7	146	5.7	435	17.0	7.5	16.5
1925+	1925	535	1133	2	146	5.7	146	5.7	435	17.0	7.5	16.5
3200+	3200	889	1883	2	146	5.7	146	5.7	635	24.8	10	22.0
<b>50 bar Stainless Steel</b>												
100+	100	28	59	1/4	85	3.3	85	3.3	202	7.9	1.7	3.7
200+	200	56	118	3/8	85	3.3	85	3.3	227	8.9	2	4.4
340+	340	94	200	1/2	85	3.3	85	3.3	257	10.0	2.2	4.8
500+	500	139	294	3/4	110	4.3	110	4.3	270	10.5	4	8.8
1000+	1000	278	589	1	110	4.3	110	4.3	422	16.5	5	11.0
1700+	1700	472	1000	1 1/2	150	5.9	150	5.9	517	20.2	15	33.1
2040+	2040	567	1200	2	150	5.9	150	5.9	517	20.2	15	33.1
3400+	3400	944	2000	2	150	5.9	150	5.9	817	31.9	21	46.3
<b>100 bar Stainless Steel</b>												
100+	100	28	59	1/4	65	2.5	65	2.5	135	5.3	3.2	7.1
315+	315	88	185	1/2	65	2.5	65	2.5	250	9.8	5.6	12.3
460+	460	128	271	3/4	88	3.4	88	3.4	275	10.7	6.1	13.4
680+	680	189	400	1	135	5.3	135	5.3	265	10.3	10.5	23.1
1200+	1200	333	706	1	135	5.3	135	5.3	480	18.7	14.7	32.4
1700+	1700	472	1000	1 1/2	150	5.9	150	5.9	525	20.5	22	48.5
3400+	3400	944	2000	2	150	5.9	150	5.9	815	31.8	28	61.7
<b>350 bar Stainless Steel</b>												
48+	48	13	28	1/4	41	1.6	41	1.6	103	4.0	1.6	3.5
111+	111	31	65	1/4	65	2.5	65	2.5	135	5.3	3.2	7.1
255+	255	71	150	1/2	88.5	3.5	88.5	3.5	210	8.2	5.6	12.3
510+	510	142	300	3/4	88.5	3.5	88.5	3.5	280	10.9	6.1	13.4
750+	750	208	441	1	150	5.9	150	5.9	330	12.9	14.5	32.0
1330+	1330	369	783	1	150	5.9	150	5.9	480	18.7	17.4	38.3

## Correction factors

<b>20 bar Aluminum</b>										
Operating pressure	barg	-	-	-	-	-	14	16	18	20
	psig	-	-	-	-	-	203	232	261	290
Correction factor							0.9	0.95	1	1.05
<b>50 bar Aluminum &amp; Stainless Steel</b>										
Operating pressure	barg	4	6	8	10	15	20	30	40	50
	psig	58	87	116	145	218	290	435	581	726
Correction factor		0.14	0.22	0.28	0.34	0.47	0.56	0.7	0.85	1
<b>100 bar Stainless Steel</b>										
Operating pressure	barg	20	30	40	50	60	70	80	90	100
	psig	290	435	581	726	871	1016	1161	1306	1451
Correction factor		0.45	0.57	0.68	0.8	0.84	0.88	0.92	0.96	1
<b>350 bar Stainless Steel</b>										
Operating pressure	barg	-	-	50	100	150	200	250	300	350
	psig	-	-	726	1451	2177	2903	3628	4354	5080
Correction factor				0.73	0.78	0.82	0.87	0.91	0.96	1



### Example

- Working pressure 300 bar(g), compressed air flow 500 m³/h.
- Multiply the nominal capacity of the selected filter with the corresponding correction factor at the required working pressure to obtain the capacity at working pressure:
  - Size 510+: 510 m³/h \* 0.96 = 490 m³/h => the 510+ filter size is not large enough.
  - Size 750+: 750 m³/h \* 0.96 = 720 m³/h => the 750+ filter size is the size to select.

# MV SERIES

## Medical vacuum filters for optimal protection of man and machine

Medical vacuum filters are installed at the inlet of the vacuum pump to remove any liquid, solid or bacterial contamination which could damage the vacuum pump and biologically infect the downstream air. Our innovative medical vacuum filtration solutions comply with HTM medical standards.



## YOUR BENEFITS

### Maximum contaminant removal

Removal of dry and wet dust, particulates, oil aerosol and water droplets. High-efficiency glass fiber and fleece media.

### Significant energy savings & limited system operation cost

Optimal design and filter media allow for low pressure losses.

### High reliability

High performance stainless steel cores, double O-rings, epoxy sealed caps and anti-corrosive coated filter housing.

### Easy maintenance

External ribs on the threaded housing and push-on elements.

### Monitoring of energy use

Differential pressure indication show the pressure loss.

## Applications

- Medical
- Dental
- Veterinary

## Performance

	MV
Contaminant	Dry dust
Maximum temperature	60°C/140°F
Maximum working vacuum	Full vacuum
Test method	Sodium flame test BS 3928:1969, based on requirements of HTM2022
Particle removal efficiency (%)*	99.995
Dry pressure drop (mbar)	30
Element service	After 2,000 operating hours or 1 year or 100 mbar pressure drop

\* In accordance with BS 3928-1969.

## Sizing & dimensions

FILTER SIZE MV	Nominal Capacity	Connections	Dimensions						Weight	
			A		B		C			
			l/min	in	mm	in	mm	in	mm	in
10	400	1/2	60	2	90	4	240	9	1.3	2.9
20	800	1	76	3	110	4	300	12	2.1	4.6
60	2400	1 1/2	103	4	140	5	489	19	4.6	10.1
80	3400	2	135	5	179	7	575	22	6.9	15.2
120	4900	3	155	6	210	8	677	26	11.0	24.2
160	6700	3	155	6	210	8	847	33	12.6	27.8

## Correction factors

Operating pressure	bar(a)	0.1	0.2	0.3	0.4	0.5	0.6	0.7	0.8	0.9	1
	Psig	1	3	4	6	7	9	10	12	13	15
	Torr = mm Hg	75	150	225	300	375	450	525	600	675	750
Correction factor		0.1	0.2	0.3	0.4	0.5	0.6	0.7	0.8	0.9	1

### Example

- Working vacuum 300 mbar(a), capacity 1,000 l/min.
- Multiply the nominal capacity of the selected filter with the corresponding correction factor at the required working vacuum to obtain the correct capacity:
  - Size 60: 2,400 l/min \* 0.3 = 720 l/min => the 60 filter size is not large enough.
  - Size 80: 3,400 l/min \* 0.3 = 1,020 l/min => the 80 filter size is the size to select.



## Options

- Wall mounting kit.
- Drain flask.



Drain flask



## Certification

BS 3928 Sodium flame test certificate based on requirements of HTM2022.



Atlas Copco

atlascopco.com

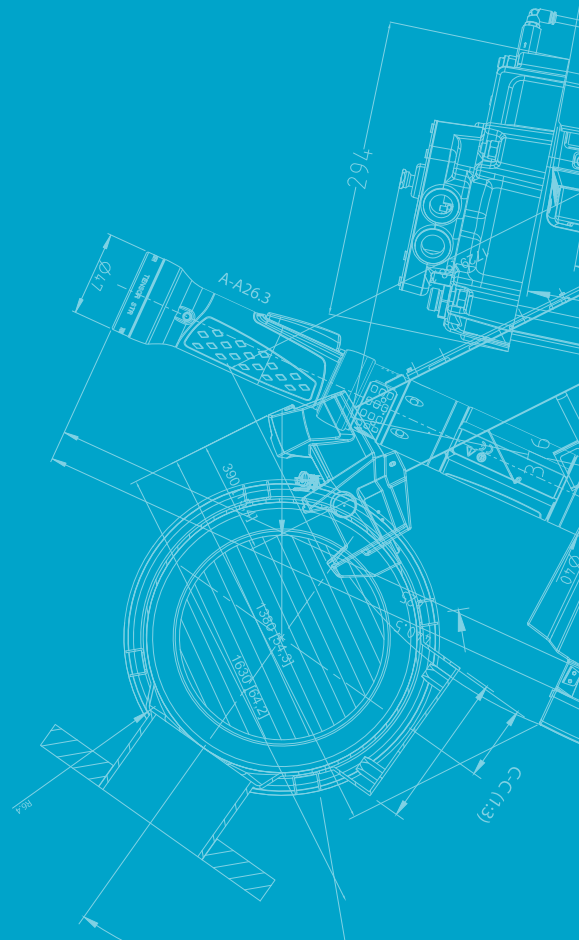

2935 0932 44 © 2018. Atlas Copco Airpower NV, Belgium. All rights reserved. Designs and specifications are subject to change without notice or obligation. Read all safety instructions in the manual before usage.



# Quality Air Solutions

## Compressed Air Filters

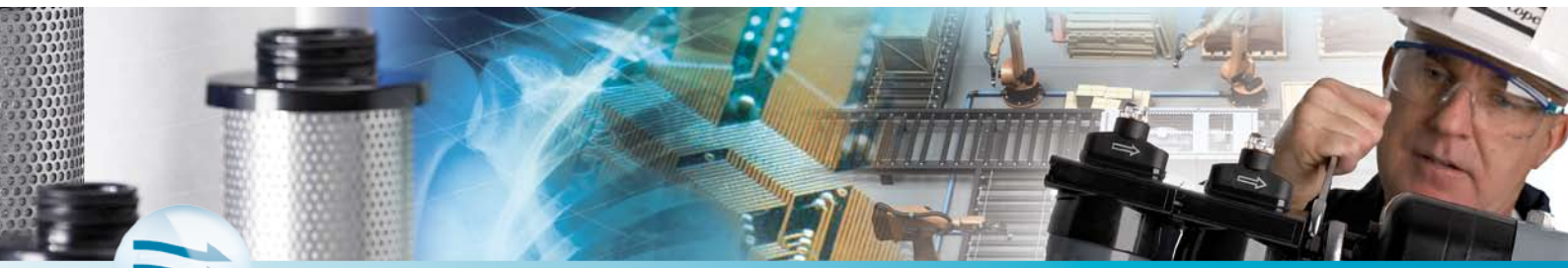

## The ultimate protection

When air is compressed, the concentration of dirt particles, oil carryover and moisture increases. This creates an abrasive mixture that, when left as such, may bring about severe instrument failures and even contaminate your end product. To protect your investment, equipment and processes, Atlas Copco presents a complete range of innovative filtration solutions to efficiently reduce all types of contamination with minimal pressure drop.



### **YOUR BENEFITS:**

- Maximum contaminant removal
- Significant energy savings
- Limited system operating costs
- Increased reliability
- Easy maintenance



**Atlas Copco**

# Technical specifications

## DD, DDp, PD, PDp, QD AIR FILTERS & HIGH PRESSURE MODELS

FILTER SIZE	Nominal capacity (1)		Maximum capacity (1)		Connections G or NPT	Dimensions						Free space for cartridge replacement		Weight	
	l/s	cfm	l/s	cfm		A		B		C		D		kg	lbs
DD, DDp, PD, PDp, QD	l/s	cfm	l/s	cfm		mm	in	mm	in	mm	in	mm	in	kg	lbs
9	9	19	11	23	3/8	90	3.54	61	2.40	268	10.55	75	2.95	1	2.2
17	17	36	21	45	1/2	90	3.54	61	2.40	268	10.55	75	2.95	1.1	2.4
32	32	68	40	85	1/2	90	3.54	61	2.40	323	12.72	75	2.95	1.3	2.9
44	44	93	55	117	3/4 & 1	110	4.33	98.5	3.88	374	14.72	75	2.95	1.9	4.19
60	60	127	75	159	1	110	4.33	98.5	3.88	414	16.3	75	2.95	2.1	4.6
120	120	254	150	318	1-1/2	140	5.51	105	4.13	520	20.47	100	3.94	4.2	9.3
150	150	318	188	399	1-1/2	140	5.51	105	4.13	603	23.74	100	3.94	4.5	9.9
175	175	371	219	464	1-1/2	140	5.51	105	4.13	603	23.74	100	3.94	4.6	10.1
280	280	594	350	742	2 & 2-1/2	179	7.05	121	4.76	689	27.13	150	5.91	6.9	15.2
390	390	827	488	1035	3	210	8.27	128	5.04	791	31.14	200	7.87	11	24.2
520	520	1102	650	1378	3	210	8.27	128	5.04	961	37.83	200	7.87	12.6	27.8
520F	520	1102	650	1378	DN80	370	14.57	190	7.48	930	36.61	660	25.98	70	154.3
780F	780	1654	975	2067	DN100	510	20.08	230	9.06	935	36.81	630	24.8	130	286.6
1050F	1050	2226	1313	2784	DN100	510	20.08	230	9.06	935	36.81	630	24.8	130	286.6
1400F	1400	2968	1750	3710	DN150	620	24.41	290	11.42	1065	41.93	625	24.61	190	418.9
1800F	1800	3816	2250	4770	DN150	640	25.2	280	11.02	1130	44.49	560	22.05	210	463.0
2100F	2100	4452	2625	5565	DN150	690	27.17	290	11.42	1140	44.88	560	22.05	250	551.2
2700F	2700	5724	3375	7155	DN200	820	32.28	350	13.78	1280	50.39	650	25.59	330	727.5
3150F	3150	6678	3938	8349	DN200	820	32.28	350	13.78	1280	50.39	650	25.59	330	727.5
4800F	4800	10176	6000	12720	DN250	862	33.94	469	18.46	1352 (2)	53.23	800	31.5	540	1190.5
7200F	7200	15256	9000	19080	DN300	1000	39.37	533	20.98	1377 (2)	54.21	850	33.46	700	1543.2

(1) Nominal pressure: 7 bar(e)/102 psig; temperature 20°C, 68°F

(2) Distance from the center of the flange down to the lowest point of the vessel.

Maximum air inlet temperature

DD/DDp/PD/PDp: 66°C (151°F)

QD: 35°C (95°F)

## 20 BAR - HIGH PRESSURE FILTERS

FILTER SIZE	Inlet capacity		Maximum inlet pressure		Connections G or NPT	Dimensions				Free space for cartridge replacement		Weight	
	l/s	cfm	bar(e)	psig		A		C		D		kg	lbs
DDH, DDpH, PDH, PDpH, QDH	l/s	cfm	bar(e)	psig		mm	in	mm	in	mm	in	kg	lbs
14	14	30	20	290	3/8	90	3.54	321	12.64	75	2.95	1	2.2
27	27	57	20	290	3/8	90	3.54	321	12.64	75	2.95	1.1	2.4
50	50	106	20	290	1/2	90	3.54	376	14.8	75	2.95	1.3	2.9
70	70	148	20	290	3/4	110	4.33	396	15.59	75	2.95	1.9	4.2
95	95	201	20	290	3/4	110	4.33	436	17.17	75	2.95	2.1	4.6
185	185	392	20	290	1-1/2	140	5.51	546	21.5	100	3.94	4.2	9.3
240	240	509	20	290	1-1/2	140	5.51	626	24.65	100	3.94	4.5	9.9
275	275	583	20	290	1-1/2	140	5.51	626	24.65	100	3.94	4.6	10.1
445	445	943	20	290	2	179	7.05	711	28	150	5.91	6.9	15.2

## PRESSURE DROP

	DD	DDp	PD	PDp	QD
Initial pressure drop at nominal capacity (dry)	0.05	0.05	0.08	0.08	0.07
Initial pressure drop at nominal capacity (wet)	0.12	N/A	0.2	N/A	N/A

For other compressed air inlet pressures, multiply the filter capacity by the following correction factors:

Inlet pressure	bar	2	4	6	7	8	10	12	14	16
Inlet pressure	psig	29	58	87	102	116	145	174	203	232
Correction factor		0.53	0.75	0.92	1	1.06	1.2	1.31	1.41	1.5

N/A: Not applicable.

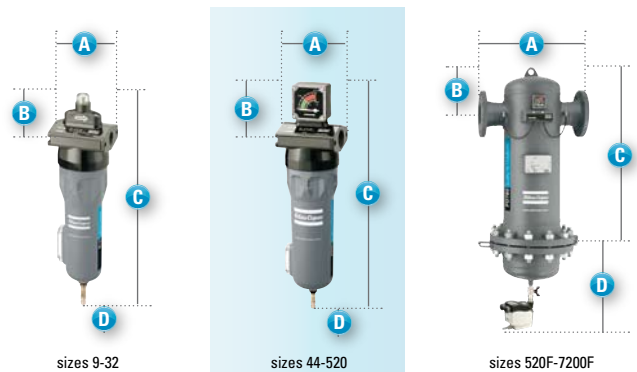

Never use compressed air as breathing air without prior purification in accordance with local legislation and standards.

www.atlascopco.com





# ***PARTS LIST***

## ***PSA OXYGEN GENERATORS***

OGP 2, OGP 3, OGP 4, OGP 5, OGP 6, OGP 8, OGP 10, OGP 14, OGP 18, OGP 20,  
OGP 23, OGP 29, OGP 35, OGP 45, OGP 55, OGP 65, OGP 84, OGP 105, OGP 160,  
OGP 200





# Atlas Copco

## PSA Oxygen generators

OGP 2, OGP 3, OGP 4, OGP 5, OGP 6, OGP 8, OGP 10,  
OGP 14, OGP 18, OGP 20, OGP 23, OGP 29, OGP 35,  
OGP 45, OGP 55, OGP 65, OGP 84, OGP 105, OGP 160,  
OGP 200

From following serial No. onwards: DKB 101 000

### Parts list

- Copyright, Atlas Copco Airpower n.v., Antwerp, Belgium.  
Any unauthorized use or copying of the contents or any part thereof is prohibited.  
This applies in particular to trademarks, model denominations, part numbers and drawings.
- **Use only authorized parts.** Any damage or malfunction caused by the use of unauthorized parts is not covered by Warranty or Product Liability.

2015 - 03

No. 2930 7125 41  
Replaces No. 2930 7125 40

[www.atlascopco.com](http://www.atlascopco.com)



## en - INSTRUCTIONS FOR USE

### 1 ORDERING PARTS

Always specify the part number, the name and quantity of the required items, as well as the type and serial number of the machine.

Pages marked with Service symbol -  contain parts of Service kit(s). For complete contents of the kit see chapter "1 - Service kits".

### 2 COLUMN INFORMATION

**Ref.** - Reference number: links a specific listed part to the drawing. Only parts with a reference number are shown in the drawing. Parts in the drawing without a reference number are simply there to illustrate the assembly.

**Part number** - Part number: if no part number is specified, the component is not available as a spare part. A line shown in bold is an assembly. A part of which the number is followed by a black dot is comprised in the bold printed assembly right above.

"<<< >>>" Directs to another list with the same title as the "Name".

When the part number of the specific parts is placed below the "Ref./"Name" line a choice must be made upon the type/version of the machine.

**Qty** - Quantity: indicates the number of parts in connection with the corresponding reference number. „AR“ means „As required“: quantity or number to be determined.

**Name** - Part name: translations of the English names can be found in document "Glossary of part names".

**Remarks** - Extra information about the part.

A series of letters can indicate that a particular part has been certified by the specified authorized body, in accordance with the codes or rules of the list.

Measurements are given in millimeters.

## bg - ИНСТРУКЦИИ ЗА ИЗПОЛЗВАНЕ

### 1 ЗАЯВЯВАНЕ НА РЕЗЕРВНИ ЧАСТИ

Винаги указвайте номера на частта, наименованието и необходимото количество от артикула, както и модела и серийния номер на машината.

Страниците, маркирани със символ за сервиз - , съдържат части от Сервизен комплект(и). За пълното съдържание на комплекта вж. глава "1 - Service kits" (1 - Сервизни комплекти).

### 2 ЗНАЧЕНИЕ НА КОЛОНИТЕ

**Ref.** - Цифрово обозначение: връзка с чертежа за определена част от спецификацията. На чертежа са показани само детайли с цифрово обозначение. Детайлите без цифрово обозначение в чертежа са показани само за прегледност на сглобената единица.

**Part number** - Номер на частта: ако не е указан такъв, детайлт не се предлага като резервна част. Удебелена линия означава сглобена единица. Част, чийто номер е последван от черна точка, се съдържа в сглобената единица, отпечатана точно отгоре с получер шрифт.

"<<< >>>" е указател към друга спецификация със същото наименование като "Name".

Когато номерът на частта на указания детайл е разположен под реда "Ref./"Name", трябва да се направи избор съобразно модела/версията на машината.

**Qty** - Количество: указва броя детайли, свързани със съответното цифрово обозначение. "Заявка" означава "По заявка": количество или бройка за доуточняване.

**Name** - Наименование на частта: преводите на английските наименования могат да бъдат намерени в документа "Речник на наименованията на частите".

**Remarks** - Допълнителна информация за частта.

Поредица от букви може да указва, че определен детайл е сертифициран от посочения упълномощен орган за съответствие с параметрите или правилата в спецификацията.

Всички стойности са дадени в милиметри.

## br - INSTRUÇÕES DE USO

### 1 ENCOMENDANDO PEÇAS

Sempre especifique o número da peça, o nome e a quantidade dos itens necessários, assim como o tipo e o número de série da máquina.

Páginas marcadas com o símbolo Serviço -  contém peças do(s) Kit(s) de serviço. Para conhecer o conteúdo completo do kit, consulte o capítulo "1 - Service kits" (1 - Kits de serviço).

### 2 INFORMAÇÕES SOBRE AS COLUNAS

**Ref.** - Número de referência: indica onde está uma peça específica listada no desenho. Somente peças com número de referência são mostradas no desenho. As peças no desenho que não têm um número de referência destinam-se simplesmente a ilustrar o conjunto.

**Part number** - Número da peça: se nenhum número de peça estiver especificado, o componente não está disponível como peça sobressalente. Uma linha mostrada em negrito é um conjunto. Uma peça cujo número seja seguido por um ponto preto faz parte do conjunto impresso em negrito imediatamente acima dela.

O símbolo "<<< >>>" direciona para outra lista com o mesmo título, como "Name" (Nome).

Quando o número de peça específico é colocado abaixo da linha "Ref./"Name" (Ref. / Nome), é preciso escolher o tipo/versão da máquina.

**Qty** - Quantidade: indica o número de peças e os números de referência correspondentes. "AR" significa "As required" (Conforme solicitado): a quantidade ou o número a ser determinado.

**Name** - Nome da peça: as traduções dos nomes em inglês podem ser encontradas no documento "Glossary of part names" (Glossário de nomes de peças).

**Remarks** - Observações - Informações extras sobre a peça.

Uma série de letras pode indicar que uma determinada peça é certificada pelo órgão autorizado específico, de acordo com os códigos ou as regras da lista.

As medidas são fornecidas em milímetros.

## cs - NÁVOD K POUŽITÍ

### 1 OBJEDNÁNÍ DÍLŮ

Vždy uveďte přesné číslo dílu, název a množství požadovaných položek, a také typ a sériové číslo stroje.

Stránky označené symbolem servisu -  obsahují součásti servisní sady (servisních sad). Kompletní obsah sady naleznete v kapitole "1 - Service kits" (1, Servisní sady).

### 2 INFORMACE VE SLOUPCÍCH

**Ref.** - Referenční číslo: odkazuje díl uvedený v seznamu k místu ve výkresu. Ve výkresu jsou uvedeny pouze díly s referenčním číslem. Díly bez referenčního čísla, které jsou ve výkresu uvedeny, slouží pouze jako ilustrace.

**Part number** - Číslo dílu: pokud není uvedeno číslo dílu, component se jako náhradní díl nedodává. Řádek tučně je sestava. Díl, jehož číslo je následováno černou tečkou, je součástí sestavy, jejíž název je vtištěn tučně výše.

"<<< >>>" vede na další seznam se stejným názvem, jaký je uveden v poli „Name“ (Název dílu).

Pokud je pod řádkem „Ref./"Name" umístěno číslo dílu konkrétního dílu, musí být proveden výběr typu/verze stroje.

**Qty** - Množství: uvádí počet dílů spojených s příslušným referenčním číslem. „AR“ znamená „As required“ (podle požadavků): množství nebo číslo, které má být určeno.

**Name** - Název dílu: překlad anglického názvu lze najít v dokumentu „Rejstřík názvů dílů“.

**Remarks** - Doplnkové informace k dílu.

Série písmen může označovat, že určitý díl byl certifikován autorizovanou osobou v souladu s kódy a pravidly seznamu.

Rozměry jsou uvedeny v milimetrech.



## da - ANVENDELSESIKSTRUKTIONER

### 1 BESTILLING AF RESERVEDELE

Angiv altid reservedelsnummer, navn og antal for de dele, du ønsker, samt maskinens typebetegnelse og serienummer.

Sider markeret med servicesymbolet -  " indeholder dele af service-kittet(ene). For et samlet overblik over kittets indhold, se kapitel "1 - Service kits"(1 - Service kits).

### 2 FORKLARING TIL SPALTER

**Ref.** - Referencenummer: knytter en specifik del på listen til tegningen. På tegningen vises kun reservedele, som har et referencenummer. Reservedele på tegningen, som ikke har et referencenummer, er medtaget for illustrationens skyld.

**Part number.** - Reservedelsnummer: hvis der ikke er angivet noget reservedelsnummer, fås den pågældende komponent ikke som reservedel. En linje, som vises med fed skrift, er en samling af dele. En reservedel, hvor nummeret er efterfulgt af en sort prik, er en af de dele, der indgår i samlingen af dele, som vises med fed skrift ovenover. "<<<< >>>>" henviser til en anden liste med samme titel som "Name".

Når den specifikke reservedelsnummer placeres under linjen "Ref./Name", skal du vælge type/version for maskinen.

**Qty** - Antal: angiver antallet af reservedele, der indgår i det tilsvarende referencenummer. "AR" betyder "As required" (som krævet): mængde eller antal skal bestemmes.

**Name** - Reservedelsnavn: oversættelse af de engelske navne kan findes i dokumentet "Liste over reservedelsnavne".

**Remarks** - Ekstra information om reservedelen.

En bogstavrække kan angive, at en bestemt reservedel er blevet certificeret af det pågældende godkendende organ, i henhold til standarderne på listen.

Alle mål er angivet i millimeter.

## de - BEDIENUNGSANWEISUNG

### 1 BESTELLEN VON TEILEN

Immer Teilenummer, Bezeichnung und Anzahl der erforderlichen Teile sowie Typ und Seriennummer der Maschine angeben.

Seiten mit dem Servicesymbol -  " enthalten Teile von Service-Kit(s). Informationen zum vollständigen Inhalt des Kits finden Sie im Kapitel „1 - Service kits“ (1 - Service-Kits).

### 2 ERLÄUTERUNG DER SPALTEN

**Ref.** - Referenznummer: Querverweis zwischen einem aufgeführten Teil und der Zeichnung. In der Zeichnung sind nur Teile mit einer Referenznummer abgebildet. Abgebildete Teile ohne Referenznummer dienen lediglich der Darstellung der Baugruppe.

**Part number** - Teilenummer: Falls keine Teilenummer angegeben ist, ist das Bauteil nicht als Ersatzteil lieferbar. Baugruppen sind fett hervorgehoben. Wenn sich hinter einer Teilenummer ein schwarzer Punkt befindet, gehört dieses Teil zur darüber stehenden Baugruppe.

"<<<< >>>>" bedeutet, daß Sie eine andere Liste nachschlagen müssen.

Steht die Teilnummer unter der Ref./Name Zeile, so muß eine Wahl gemacht werden je nach Typ/Ausführung der Maschine.

**Qty** - Anzahl: Gib die Anzahl der Teile in Bezug auf die entsprechende Referenznummer an. „AR“ steht für „As required“ (nach Bedarf), die gewünschte Anzahl muss angegeben werden.

**Name** - Teilebezeichnung: Eine Übersetzung der englischen Bezeichnungen finden Sie im Dokument "Glossary of part names" (Glossar Teilebezeichnungen).

**Remarks** - Zusätzliche Information zu dem Teil.

Eine Buchstabenfolge weist darauf hin, dass ein bestimmtes Teil durch die angegebene zuständige Stelle gemäß den aufgeführten Normen und Richtlinien zertifiziert wurde.

Abmessungen sind in Millimetern angegeben.

## el - ΟΔΗΓΙΕΣ ΧΡΗΣΗΣ

### 1 ΠΑΡΑΓΓΕΛΙΑ ΑΝΤΑΛΛΑΚΤΙΚΩΝ

Να προσδιορίζετε πάντοτε τον κωδικό είδους, την περιγραφή και την ποσότητα των αιτούμενων ειδών καθώς, επίσης, και τον τύπο και τον αριθμό σειράς του μηχανήματος.

Οι σελίδες που επισημαίνονται με το σύμβολο Σέρβις-  " περιέχουν μέρη από Πακέτα ανταλλακτικών συντήρησης. Για το πλήρες περιεχόμενο του πακέτου, ανατρέξτε στο κεφάλαιο "1 - Service kits" (1 - Πακέτα ανταλλακτικών συντήρησης).

### 2 ΠΛΗΡΟΦΟΡΙΕΣ ΓΙΑ ΤΗ ΣΥΜΠΛΗΡΩΣΗ ΤΩΝ ΣΤΗΛΩΝ

**Ref.** - Κωδικός αναφοράς: συνδέει ένα συγκεκριμένο λειτουργικό εξάρτημα του καταλόγου με το σχέδιο. Στο σχέδιο εμφανίζονται μόνο εξαρτήματα που διαθέτουν κωδικό αναφοράς. Τα εξαρτήματα του σχεδίου που δε διαθέτουν κωδικό αναφοράς απλώς εμφανίζονται για την πληρέστερη περιγραφή του συγκροτήματος.

**Part number** - Κωδικός είδους: εάν δεν προσδιορίζεται κωδικός είδους, το εξάρτημα δεν είναι διαθέσιμο ως ανταλλακτικό. Γραμμές που εμφανίζονται με έντονη γραφή αντιστοιχούν σε συγκροτήματα. Ένα εξάρτημα του οποίου ο κωδικός ακολουθείται από μαύρη τελεία περιλαμβάνεται στο αμέσως παραπάνω συγκρότημα που εμφανίζεται με έντονη γραφή.

Το "<<<< >>>>" αποτελεί αναφορά σε άλλο κατάλογο με τον τίτλο που αναγράφεται στην ένδειξη "Name".

Όταν ο κωδικός είδους του προσδιοριζόμενου εξαρτήματος βρίσκεται κάτω από τη γραμμή "Ref./Name", θα πρέπει να γίνει επιλογή του τύπου/έκδοσης του μηχανήματος.

**Qty** - Ποσότητα: υποδεικνύει το πλήθος των εξαρτημάτων που ζητούνται από τον αντίστοιχο κωδικό αναφοράς. "AR" σημαίνει "As required" (Σύμφωνα με τις απαιτήσεις): ποσότητα ή πλήθος προς προσδιορισμό.

**Name** - Περιγραφή είδους: μεταφράσεις των αγγλικών ονομασιών περιέχονται στο έντυπο "Γλωσσάριο εξαρτημάτων".

**Remarks** - Πρόσθετες πληροφορίες σχετικά με ένα ανταλλακτικό.

Η ύπαρξη μιας σειράς γραμμάτων υποδεικνύει ότι ένα συγκεκριμένο ανταλλακτικό διαθέτει έγκριση από τον αναφερόμενο εξουσιοδοτημένο φορέα, σύμφωνα με τους κώδικες ή τους κανονισμούς του καταλόγου.

Οι διαστάσεις αναφέρονται σε χιλιοστάμετρα.

## es - INSTRUCCIONES DE USO

### 1 PEDIDO DE PIEZAS

Especifique siempre la designación, el nombre y la cantidad de las piezas deseadas, así como el tipo y el número de serie de la máquina.

Las páginas marcadas con el símbolo de Servicio -  " contienen piezas de kit(s) de servicio. Para el contenido completo del kit, vea el capítulo "1 - Service kits" (1 - Kits de servicio).

### 2 INFORMACIÓN DE LAS COLUMNAS

**Ref.** - Número de referencia: establece un vínculo entre una pieza específica de la lista y el dibujo. Sólo las piezas con número de referencia aparecen en el dibujo. Las piezas que aparezcan sin número de referencia sólo se muestran en el dibujo para ilustrar el conjunto.

**Part number** - Designación: si no se indica ninguna designación, el componente no se encuentra disponible como pieza de repuesto. Los conjuntos aparecen con una línea en negrita. Las piezas con números seguidos por un punto negro, indican que forman parte del conjunto que aparece en negrita anteriormente.

"<<<< >>>>" dirige a otra lista con el mismo título que el "Name".

Cuando la designación de una pieza específica está situada debajo de la línea "Ref./Name" se debe elegir el tipo/version de la máquina.

**Qty** - Cantidad: indica la cantidad de piezas asociadas al número de referencia correspondiente. "AR" significa "As required" (según se requiera): debe determinarse la cantidad o el número.

**Name** - Nombre de la pieza: las traducciones de los nombres en inglés se encuentran en el documento "Glosario de nombres de piezas".

**Remarks** - Observaciones: información adicional sobre las piezas.

Una serie de letras puede indicar que una pieza específica ha sido certificada por la entidad autorizada indicada, conforme a los códigos o reglas especificados.

Las dimensiones se expresan en milímetros.

## et - KASUTUSJUHISED

### 1 OSADE TELLIMINE

Määrake alati osa number, vajalike osade nimed ja kogused, samuti masina tüüp ja seerianumber.

Hooldussümboliga tähistatud leheküljed - "🔧" sisaldavad hoolduskomplekti(-de) osi. Komplekti täieliku sisu jaoks vt peatükki "1 - Service kits" (1 - Hoolduskomplektid).

### 2 VEERUTEAVE

**Ref.** viitenumber seostab konkreetse nimistus oleva osa vastava joonisega. Joonisel on toodud ainult viitenumbriga osad. Joonisel olevad viitenumbriga osad on mõeldud ainult illustatsioonidena.

**Part number:** osa number. Kui osa number pole määratud, siis pole see komponent varuosana saadaval. Rasvane joon tähistab seadet. Osa, millele järgneb must punkt, koosneb paremal üleval rasvaselt trükitud koostisest.

„<<< >>>“ viib teise loendini, millel on samasugune pealkiri kui „Nimi“.

Kui osa number või konkreetne osa on paigutatud „Viite“/„Nime“ joone alla, tuleb valida seadme tüüp/version.

**Qty:** kogus näitab vastava viitenumbriga tähistatud osade arvu. „AR“ tähendab „As required“ (Vastavalt vajadusele); määratletakse kas kogus või number.

**Name** ehk osa nimi: ingliskeelsete nimede tõlked leiata dokumentid „Osa nimede sõnastik“.

**Remarks** – osa kohta käiv lisateave.

Tähtede seeria võib näidata, et mingi osa on vastavalt nimekirja koodidele või reeglitele volitatud organist sertifitseeritud.

Mõõtmed on millimeetrites.

## fi - KÄYTTÖOHJEET

### 1 OSIEN TILAAMINEN

Mainitse aina osan numero, haluttujen osien nimitykset ja määrät, sekä koneen malli ja valmistusnumero.

Houtosymbolilla - "🔧" merkityillä sivuilla on huoltotarvikesarjojen osia. Katso sarjan täydellinen sisältö luvusta "1 - Service kits" (1 - Huoltotarvikesarjat).

### 2 SARAKKEIDEN SELITYKSET

**Ref.** - Viitenumero: Viittaa osaan luettelossa ja piirustuksessa. Vain osat, joilla on viitenumero, näkyvät piirustuksessa. Ilman viitenumeroa piirustuksessa olevien osien tarkoituksena on vain selkeyttää kokonaisuutta.

**Part number** - Osanumero: Jos osanumeroa ei ole ilmoitettu, osaa ei ole saatavana varaosana. Lihavoituna näkyvä rivi on kokonaisuus. Osa, jonka numeroa seuraa musta piste, sisältyy lähinnä ylhäällä lihavoidulla painettuun tarvikesarjaan.

“<<< >>>” kehottaa katsomaan toista luetteloa, jonka "Name"-otsikko on sama.

Kun tietyn osan osanumero on "Ref."/"Name"-viivan alapuolella, on valittava koneen tyyppi/version.

**Qty** - Määrä: Ilmoittaa viitenumeroon liittyvien osien määrän. "AR" tarkoittaa "As required" (tarpeen mukaan); irtotavaraa tai määrä on selvitettävä.

**Name** - Osanimi: englanninkielisten osanimien käännökset löytyvät painotuotteesta Osien nimien sanasto.

**Remarks** - Lisätietoa osasta.

Kirjainyhdistelmä voi ilmoittaa, että mainittu valtuutettu elin on hyväksynyt osan luettelon koodien tai sääntöjen mukaisesti.

Mitat on annettu millimetreinä.

## fr - INSTRUCTIONS D'UTILISATION

### 1 COMMANDE DE PIÈCES DÉTACHÉES

Précisez toujours le numéro de pièce, la désignation et la quantité de composants souhaitée, ainsi que le type et le numéro de série de la machine.

Les pages sur lesquelles figure le symbole d'entretien - "🔧" traitent de pièces comprises dans un/des kit(s) d'entretien. Pour le contenu complet du kit, voir le chapitre "1 - Service kits" (1 - Kits d'entretien).

### 2 INFORMATIONS DISPONIBLES DANS LES COLONNES

**Ref.** - Numéro de référence : se réfère à une pièce particulière dans la liste et le schéma. Seules les pièces auxquelles un numéro de référence a été attribué sont représentées sur le schéma. Les pièces sans numéro de référence sur le schéma sont simplement destinées à compléter l'illustration.

**Part number** - Numéro de pièce détachée : si aucun numéro de pièce n'est spécifié, le composant n'est pas disponible en tant que pièce détachée. Une ligne qui apparaît en gras correspond à un ensemble. Une pièce dont le numéro est suivi d'un point noir est comprise dans l'ensemble apparaissant en gras juste au-dessus.

“<<< >>>” indique à consulter une autre liste.

Si le numéro de pièce d'une pièces spécifiques est placé au-dessous de la ligne de référence/nom, il faut choisir le type/version de la machine.

**Qty** - Quantité : indique le nombre de pièces avec le numéro de référence correspondant. « AR » signifie « As required » (comme requis) : il s'agit de la quantité ou du nombre à déterminer.

**Name** - Désignation de la pièce : la traduction des désignations anglaises est disponible dans le document "Glossary of part names" (Glossaire des désignations des pièces).

**Remarks** - Remarques : informations supplémentaires concernant la pièce.

Une série de lettres peut indiquer qu'une pièce spécifique a été certifiée par l'organisme autorisé mentionné, conformément aux codes et règlements de la liste.

Les dimensions sont indiquées en millimètres.

## hu - HASZNÁLATI ÚTMUTATÓ

### 1 ALKATRÉSZRENDELÉS

Mindig adja meg a cikkszámot, a kért elemek nevét és mennyiségét, valamint a készülék típusát és gyári számát.

A Szerviz - "🔧" szimbólummal jelölt oldalak a szervizkészlet(ek) egyes alkatrészeire vonatkoznak. A készlet teljes tartalmát lásd az "1 - Service kits" (1 - Szervizkészletek) fejezetben.

### 2 A TÁBLÁZAT OSZLOPAI

**Ref.** - Hivatkozási szám: a felsorolt alkatrészt a megfelelő ábrához társítja. A rajzon csak hivatkozási számmal ellátott alkatrészek láthatók. Az ábra hivatkozási szám nélküli részei csak az összeszerelés módját illusztrálják.

**Part number** - ha nincs megadva cikkszám, az adott alkatrész nem kapható pótalkatrészként. A vastag vonal szerelvényt jelez. Ha a cikkszám után fekete pont áll, az alkatrész a jobbra fent vastaggal jelölt szerelvény része.

A „<<< >>>” jel átirányít egy másik listához, amely a „Name” elemmel azonos nevű.

Ha egy adott alkatrész cikkszámát a „Ref.”/„Name” oszlopba helyezik, ki kell választani a készülék típusát/verziószámát.

**Qty** - Mennyiség: az adott hivatkozási számhoz kapcsolódó alkatrészek számát jelöli. Az „AR” jelentése „As required” (igény szerint): itt megadhatja a mennyiséget vagy a számot.

**Name** - Az alkatrész neve: az angol nyelvű elnevezések fordításai az „Alkatrészek listája” c. dokumentumban található.

**Remarks** - Az alkatrészrel kapcsolatos többletinformáció.

Egy betűsor jelzi azt, hogy az adott alkatrészt az illetékes hatóság a lista kódjainak vagy szabályainak megfelelő tanúsítvánnyal látta el.

A mérési eredmények milliméterben értendők.

## it - ISTRUZIONI PER L'USO

### 1 ORDINE DI PARTI DI RICAMBIO

Indicare sempre il numero categorico, il nome e la quantità delle parti richieste, come pure il tipo e il numero di serie della macchina.

Le pagine contrassegnate dal simbolo di assistenza - “” descrivono componenti appartenenti ai kit di manutenzione. Per informazioni sul contenuto completo del kit, consultare il capitolo “1 - Service kits” (1 - Kit di manutenzione).

### 2 INFORMAZIONI SULLE COLONNE

**Ref.** - Numero di riferimento: indica un componente specifico elencato nel disegno. Nel disegno sono presenti solo i componenti con un numero di riferimento. I componenti senza numero di riferimento sono presenti al solo scopo di illustrare il gruppo.

**Part number** - Numero categorico: se non è specificato nessun numero categorico, il componente non è disponibile come parte di ricambio. Una riga in grassetto indica un assemblaggio. Una parte il cui numero è seguito da un punto nero è compresa nell'assemblaggio stampato in grassetto in alto a destra.

“<<<<>>>>” indica di consultare un altro elenco di parti di ricambio.

Quando il numero di catalogo di una parte specifica è messo sotto la linea del riferimento/denominazione si deve fare una scelta in base al tipo/versione della macchina.

**Qty** - Quantità: indica il numero di componenti relativo al numero di riferimento. „AR“ significa „As required“ (Come richiesto): devono essere determinati la quantità o il numero.

**Name** - Nome parte: le traduzioni dei nomi inglesi dei componenti possono essere reperite nel “Glossary of part names” (Glossario dei nomi parti).

**Remarks** - Ulteriori informazioni sul componente.

Una serie di lettere possono indicare la certificazione di un componente da parte di un ente autorizzato specificato, in conformità alle normative riportate nell'elenco.

Le misure sono espresse in millimetri.

## ja - 使用方法

### 1 部品の注文

部品番号、注文するアイテムの名称および数量、機器のタイプおよびシリアル番号を必ず指定してください。

サービスマーク “” のついたページにはサービスキットの部品が記載されています。キットの内容物については、第1章「サービスキット」を参照してください。

### 2 各列の説明

**Ref.** - 参照番号: リストの部品が図のどこにあるかを示します。参照番号がある部品のみが図に示されています。参照番号がない部品はアセンブリを表現するため便宜上表記されています。

**Part number** - 部品番号: 部品番号が示されていない部品は、スペア部品としては提供されていません。太字の行はアセンブリを示します。番号の後に黒い点が付いている部品は、すぐ上にある太字のアセンブリを構成しています。

“<<<<>>>>” は、“Name” と同じタイトルの別のリストを示します。

“Ref.” または “Name” 行の下に、特定の部品の部品番号が記載されている場合は、機器のタイプ/バージョンに応じて部品を選択してください。

**Qty** - 数量: 参照番号に対応する部品の数量を示します。 „AR” は「必要に応じて」を意味し、必要に応じて数量または番号を指定します。

**Name** - 部品名: 英語に対応する各言語の名称は「Glossary of part names」(部品名称対応表)に記載されています。

**Remarks** - 部品に関する追加情報です。

一連の文字列は特定の部品が指定認定団体によって承認されていることを示し、リストのコードまたは規定に準拠しています。

測定値はミリメートル単位で示されています。

## lt - NAUDOJIMO INSTRUKCIJA

### 1 DETALIŲ UŽSAKYMAS

Visada nurodykite detalės numerį, pavadinimą ir reikiamą kiekį bei įrenginio tipą ir serijos numerį.

Puslapiuose, pažymetuose techninio aptarnavimo simboliu - “”, yra aptarnavimo reikmenų rinkinio (-ių) dalių. Norėdami gauti informacijos apie visą rinkinio turinį, žr. skyrių “1 - Service kits” (1 - Aptarnavimo reikmenų rinkiniai).

### 2 INFORMACIJA STULPELYJE

**Ref.** - Nuorodos numeris: susieja sąrašė nurodytą detalę ir brėžinį. Brėžinyje pavaizduotos tik detalės, turinčios nuorodos numerį. Brėžinio detalės, neturinčios nuorodos numerio, tik iliustruoja komplektinį bloką.

**Part number** - detalės numeris: jeigu detalės numeris nenurodytas, komponento kaip atsarginės detalės įsigyti negalima. Eilutėje, kuri parodyta paryškintu šriftu, yra agregatas.

Detalė, po kurios numerio eina juodas taškas, yra įmontuota paryškintu šriftu aukščiau išspausdintame agregate.

„<<<<>>>>“ nukreipia į kitą sąrašą, kurio pavadinimas toks pat, kaip „Name“ (detalės pavadinimas).

Kai specifinės detalės numeris yra nurodytas žemiau „Ref.“ (nuoroda) / „Name“ (detalės pavadinimas) eilutės, reikia apsispręsti dėl įrenginio tipo/versijos.

**Qty** - Kiekis: naudojamas su atitinkamu nuorodos numeriu ir nurodo detalių kiekį. “AR” reiškia „As required“ (prireikus): dar nežinomas kiekis ar skaičius.

**Name** - detalės pavadinimas: angliškų pavadinimų vertimus galima rasti dokumente “Įrangos dalių terminai”.

**Remarks** - Papildoma informacija apie detalę.

Raidžių derinys gali rodyti, kad konkrečiai detalei sertifikuotą išdavė įgaliota institucija pagal sąrašo nurodymus ir taisykles.

Matmenys pateikti milimetrais.

## lv - INSTRUKCIJAS LIETOŠANAI

### 1. PASŪTĪŠANAS DETALĀS

Vienmēr norādiet nepieciešamās iekārtas detaļas numuru, nosaukumu un daudzumu, kā arī tipu un mašīnas seriālo numuru.

Lappuses, kas apzīmētas ar apkopes simbolu -  satur Apkopes komplekta(u) daļas. Pilnam komplekta satura pārskatam, skatiet nodaļu "1 - Service kits" (1 - Apkopes komplekti).

### 2. KOLONNAS INFORMĀCIJA

**Ats.** - Inventāra numurs: savieno atbilstošās saraksta daļas ar attēlu. Tikai detaļas ar inventāra numuru ir parādītas attēlā. Detaļas attēlā bez inventāra numura ir montāžai, vienkārši paskaidrotas attēlā.

**Part number** – detaļas numurs: ja nav norādīts detaļas numurs, komponents nav pieejams kā rezerves detaļa. Treknrakstā parādītā līnija ir montāža. Detaļa, aiz kuras numura seko melns punkts, ir ietverta tieši augšpusē treknrakstā drukātajā montāžā.

"<<< >>>" novirza uz citu sarakstu, kuram ir tāds pats nosaukums kā "Nosaukums".

Kad kādas noteiktas detaļas numurs ir novietots zem līnijas "Ats."/"Nosaukums" ir jāizvēlas iekārtas veids/versija.

**Qty** – daudzums: norāda detaļas daudzumu savienojumā ar attiecīgo inventāra numuru. "AR" nozīmē "As required" (pēc vajadzības): daudzums vai numurs, kuru jānosaka.

**Name** – detaļas nosaukums: angļu nosaukumu tulkojumus var atrast dokumentā "Detaļu nosaukumu vārdnīca".

**Remarks** – speciāla informācija par detaļu.

Burtu rindiņa, saskaņā ar saraksta noteikumiem un kodiem, var norādīt, ka šo detaļu ir sertificējusi autorizēta organizācija.

Izmēri ir norādīti milimetros.

## nl - INSTRUCTIES VOOR HET GEBRUIK

### 1 BESTELLEN VAN ONDERDELEN

Vermeld altijd het onderdeelnummer, de benaming en de hoeveelheid van de gewenste onderdelen, alsmede het type en het serienummer van de machine.

Pagina's gemarkeerd met het servicesymbool -  bevatten onderdelen uit servicekits. Voor de complete inhoud van de kit, zie paragraaf "1 - Service kits" (1 - Servicekits).

### 2 KOLOM INFORMATIE

**Ref.** - Referentienummer: koppelt een specifiek onderdeel in de lijst aan de desbetreffende tekening. Alleen onderdelen met een referentienummer zijn in de tekening afgebeeld.

Onderdelen zonder referentienummer die op de tekening voorkomen, worden slechts getoond om het samenstel te illustreren.

**Part number** - Onderdeelnummer: indien geen onderdeelnummer is aangegeven, is de betreffende component niet als reserveonderdeel verkrijgbaar. Een regel in een vet lettertype is een samenstel. Een onderdeel waarvan het nummer gevolgd wordt door een zwart rondje, maakt deel uit van het vet afgedrukte samenstel direct erboven.

"<<< >>>" verwijst naar een andere lijst met dezelfde titel als de "Name" (benaming).

Als het onderdeelnummer van het desbetreffende onderdeel onder de regel "Ref."/"Name" (Ref./Benaming) staat vermeld, moet er een keuze met betrekking tot het machinetype en de machineversie worden gemaakt.

**Qty** - Aantal: geeft het aantal onderdelen aan in samenhang met het overeenkomstige referentienummer. "AR" betekent "As required" (benodigde hoeveelheid): de hoeveelheid of het aantal moet nader worden bepaald.

**Name** - Naam van het onderdeel: vertalingen van de Engelse benamingen zijn te vinden in het document "Glossary of part names" (Woordenlijst van onderdelen).

**Remarks** - Extra informatie over het onderdeel.

Een reeks letters kan aangeven dat een bepaald onderdeel gecertificeerd is door het opgegeven bevoegde orgaan, in overeenstemming met de codes of voorschriften in de lijst.

Afmetingen zijn in millimeters vermeld.

## no - BRUKSANVISNING

### 1 BESTILLING AV DELER

Angi alltid delenummeret, navnet og antallet deler samt type- og serienummeret for maskinen.

Sidene som er merket med Service-symbolet - , omtaler deler av servicesettene. Du finner informasjon om hele innholdet i settet i kapittel "1 - Service kits" (1 - Servicesett).

### 2 FORKLARING TIL KOLONNENE

**Ref.** – Referansenummer: knytter en bestemt del i listen til tegningen. Deler uten referansenummer vises ikke på tegningen. Delene på tegningen som ikke har referansenummer, er tatt med for å illustrere monteringen.

**Part number** – Delenummer: Hvis det ikke er angitt noe delenummer, kan ikke delen bestilles som reservedel. En fet linje er en montering. En del som har et nummer som er et-terfulgt av en svart prikk, er omfattet i monteringen med fet skrift ovenfor.

"<<< >>>" henviser til en annen liste som heter det samme som "Navn".

Når delenummeret til en bestemt del plasseres under linjen "Ref."/"Name" må man velge hva slags type/versjon maskinen er.

**Qty** – Antall: angir hvor mange deler som er knyttet til referansenummeret. "AR" står for "As required" ("etter behov"): Antall eller nummer må spesifiseres.

**Name** – Delenavn: Oversettelsene av de engelske navnene finner du i dokumentet Ordliste med delnavn.

**Remarks** – Anmerkninger: tilleggsinformasjon om delene.

Bokstaver kan indikere at en bestemt del er sertifisert i henhold til det autoriserte organet som er angitt, i samsvar med kodene eller reglene for listen.

Mål er angitt i millimeter.

## pl - INSTRUKCJA UŻYTKOWANIA

### 1 ZAMAWIANIE CZĘŚCI

Zawsze podawać numer części, nazwę i ilość potrzebnych elementów, a także typ i numer seryjny urządzenia.

Strony oznaczone symbolem -  zawierają części zestawów serwisowych. Pełną zawartość zestawów można znaleźć w rozdziale "1 - Service kits" (1 - Zestawy serwisowe).

### 2 OBJAŚNIENIA KOLUMN

**Ref.** - Numer referencyjny: łączy konkretną część z listy ze schematem. Na schemacie prezentowane są wyłącznie części posiadające numer referencyjny. Części na schemacie nie mające numeru referencyjnego umieszczono w celu zilustrowania montażu.

**Part number** - Numer części: jeśli nie podano numeru części, dany element nie jest dostępny jako część zapasowa. Tekst wytłuszczony oznacza zespół. Część, po numerze której występuje czarna kropka, wchodzi w skład wytłuszczonego zespołu wskazanego powyżej po prawej stronie.

„<<< >>>” służą do przechodzenia do innej listy o tym samym tytule, co w kolumnie „Name” (Nazwa).

Jeśli numer dla konkretnej części jest umieszczony poniżej wiersza „Ref.”/„Name”, należy wybrać typ/wersję maszyny.

**Qty** - Ilość: oznacza liczbę części w odniesieniu do odpowiadającego im numeru referencyjnego. „AR” oznacza „As required” (Wg zapotrzebowania): ilość zostanie uzgodniona.

**Name** - Nazwa części: tłumaczenie nazw angielskich można znaleźć w dokumencie „Glossary of part names” (Słownik części).

**Remarks** - Informacje dodatkowe o danej części.

Ciąg liter może informować, że dana część uzyskała certyfikat określonej, upoważnionej organizacji, zgodnie z kodami lub zasadami z listy.

Wymiary zostały podane w milimetrach.



## pt - INSTRUÇÕES PARA UTILIZAÇÃO

### 1 ENCOMENDA DE PEÇAS

Especificar sempre a referência da peça, o nome e a quantidade de itens necessários, bem como o tipo e o número de série da máquina.

Páginas marcadas com o símbolo de assistência -  contêm peças de kits de assistência. Para ver todos os conteúdos do kit consultar o capítulo "1 - Service kits" (1 - Kits de assistência).

### 2 INFORMAÇÃO SOBRE AS COLUNAS

**Ref.** - Número de referência: estabelece a ligação entre uma peça específica listada e o desenho. No desenho, apenas são mostradas peças com um número de referência. As peças mostradas no desenho que não apresentem um número de referência servem apenas para ilustrar o conjunto.

**Part number** - Referência da peça: se não for indicada a referência da peça, o componente não está disponível como peça sobresselente. Uma linha em negrito representa um conjunto. Uma peça cujo número esteja seguido de um ponto preto está incluída no conjunto impresso em negrito, imediatamente acima.

"<<< >>>" conduz a outra lista com o mesmo título de "Name".

Quando a referência da peça específica se encontra por baixo da linha "Ref./"Name", é preciso escolher o tipo/versão da máquina.

**Qty** - Quantidade: indica o número de peças relacionadas com o número de referência correspondente. "AR" significa "As required" (consoante requerido): quantidade ou número a determinar.

**Name** - Nome da peça: é possível encontrar traduções dos nomes ingleses das peças no documento "Glossário de designações de peças".

**Remarks** - Informação extra sobre a peça.

Uma série de letras pode indicar que uma determinada peça foi certificada pela entidade autorizada referida, de acordo com os códigos ou as normas da lista.

As medidas são indicadas em milímetros.

## ro - INSTRUCȚIUNI DE UTILIZARE

### 1 COMANDAREA PIESELOR

Specificați întotdeauna numărul de reper, numele și cantitatea articolelor necesare și tipul și numărul de serie ale mașinii.

Paginile marcate cu simbolul Service -  conțin componente din kituri de service. Pentru conținutul complet al acestui kit consultați capitolul "1 - Service kits" (1 - Kituri de service).

### 2 INFORMAȚIILE DIN COLOANE

**Ref.** - Numărul de referință: corelează piesa respectivă din listă cu desenul. În desen sunt prezentate numai piesele care au numere de referință. Piesele din desen care nu au niciun număr de referință se află acolo numai pentru a ilustra ansamblul.

**Part number** - Număr de reper: dacă nu este specificat niciun număr de reper, componenta nu este disponibilă ca piesă de schimb. O linie îngroșată reprezintă un ansamblu. Un reper al cărui număr este urmat de un punct negru este cuprins în ansamblul tipărit îngroșat de deasupra sa.

"<<< >>>" direcționează către o altă listă care are titlul identic cu "Nume".

Când numărul de reper al piesei respective este plasat sub linia "Referință"/"Nume", este obligatorie selectarea unui tip sau a unei versiuni a mașinii.

**Qty** - cantitate: indică numărul de piese corespunzătoare numărului de referință respectiv. "AR" înseamnă "Conform necesar": cantitate sau număr care urmează a fi determinat.

**Name** - Nume reper: traducerea numelor englezești pot fi găsite în documentul "Glosar de nume de repere".

**Remarks** - Informații suplimentare despre piese.

O serie de litere poate indica faptul că o anumită piesă a fost certificată de organismul de autorizare specificat, în conformitate cu regulile sau codurile listei.

Dimensiunile sunt date în milimetri.

## ru - Правила пользования

### 1 ЗАКАЗ ДЕТАЛЕЙ

Всегда указывайте номер по каталогу, наименование и количество требуемых позиций, а также тип и серийный номер машины. Страницы, помеченные символом Service - , содержат информацию о сервисном(ых) наборе(ах). Полное содержание сервисного набора приведено в главе "1 - Service kits" (1 - Сервисные наборы).

### 2 ИНФОРМАЦИЯ О СТОЛБЦЕ

**Ref.** - Справочный номер: связывает деталь, указанную в списке, с чертежом. На чертеже показаны только детали, имеющие справочные номера. Детали на чертеже без справочных номеров показаны только для иллюстрации сборки.

**Partnumber** - Каталогный номер: если каталожный номер не указан, то данный компонент нельзя заказать как запчасть. Жирным шрифтом показаны сборочные единицы. Деталь, после номера которой следует черная точка, входит в состав сборочной единицы, набранной жирным шрифтом непосредственно над ней. Кавычки "<<< >>>" ссылаются на другой список того же наименования, что и "Name" (Наименование детали).

Если каталожный номер находится под линией "Ref./"Name", это означает, что необходимо сделать выбор в соответствии с типом/исполнением машины.

**Qty** - Количество: указывает количество деталей в соответствии с их справочным номером. "AR" означает "As required" (По требованию): количество или номер необходимо определить.

**Name** - Наименование детали: перевод английских наименований находится в "Glossary of Part Names" (Словаре наименований деталей).

**Remarks** - Примечания - дополнительная информация о детали. Ряд букв может означать, что конкретная деталь сертифицирована указанным уполномоченным лицом, в соответствии с кодами или правилами в перечне. Размеры даны в миллиметрах.

## sk - NÁVOD NA POUŽITIE

### 1 OBJEDNÁVANIE SÚČASTÍ

Vždy zadajte číslo súčasti, názov a množstvo požadovaných položiek a takisto typ a výrobné číslo zariadenia.

Strany označené servisným symbolom -  obsahujú časti servisnej súpravy/servisných súprav. Úplný zoznam príslušnej súpravy nájdete v kapitole "1 - Service kits" (1 - Servisné súpravy).

### 2 INFORMÁCIE V STĹPCOCH

**Ref.** - Referenčné číslo: slúži na prepojenie konkrétnej uvedenej súčasti k príslušnému výkresu. Na výkrese sú zobrazené len súčasti s referenčným číslom. Súčasti bez referenčného čísla na výkrese slúžia len na ilustráciu montážnej skupiny.

**Part number** - Číslo súčasti: ak nie je určené žiadne číslo súčasti, daný komponent nie je k dispozícii ako náhradná súčiastka. Riadok uvedený tučným písmom predstavuje montážnu skupinu. Súčasť, za ktorej číslom nasleduje čierna bodka, je zahnutá vo vyššie uvedenej hrube vytlačenej zostave vpravo.

„<<< >>>“ smeruje na ďalší zoznam s rovnakým názvom ako v položke „Name“.

Keď sa číslo určitej súčasti nachádza pod riadkom „Ref./"Name“, je potrebné vybrať typ/verziu zariadenia.

**Qty** - Množstvo: označuje počet súčastí vzhľadom na príslušné referenčné číslo. Skratka „AR“ znamená „As required“ (podľa potreby): množstvo alebo číslo bude stanovené.

**Name** - Názov súčastky: preklady anglických názvov môžete nájsť v dokumente „Register názvov súčastí“.

**Remarks** - Ďalšie informácie o danej súčasti.

Postupnosť písmen môže určovať, že určitá súčasť bola certifikovaná stanovenou oprávnenou inštitúciou podľa kódov alebo pravidiel v danom zozname.

Rozmery sú uvedené v milimetroch.

## sl - NAVODILA ZA UPORABO

### 1 NAROČANJE DELOV

Vedno navedite številko dela, ime in količino zahtevanih predmetov ter tip in serijsko številko stroja.

Strani, označene s simbolom za servis "🔧", vsebujejo dele servisnih kompletov. Za celotno vsebino kompleta si oglejte poglavje "1 - Service kits" (1 - Servisni kompleti).

### 2 INFORMACIJE O STOLPCU

**Ref.** - Referenčna številka: povezuje določen navedeni del z risbo. Na risbi so prikazani samo deli z referenčno številko. Deli na risbi, ki nimajo referenčne številke, so namenjeni samo prikazu sklopa.

**Part number** - Številka dela: če številka dela ni navedena, komponenta ni na voljo kot rezervni del. Vrstica z odebeljenim tiskom predstavlja sklop. Del, katerega številki sledi črna pika, spada v sklop, natisnjen z odebeljenim tiskom neposredno nad njim.

"<<< >>>" vas usmeri na drug seznam z enakim nazivom kot "Name (Ime)".

Če je pod vrstico "Ref."/"Name" navedena številka dela za določeni del, mora izbrati temeljiti na tipu/različici stroja.

**Qty** - Količina: določa število delov v povezavi z ustrežno referenčno številko. "AR" pomeni "As required" (kot je zahtevano): količina ali število za določitev.

**Name** - Ime dela: prevodi angleških imen se nahajajo v dokumentu "Pojmovnik z imeni delov".

**Remarks** - Dodatne informacije o delu.

Zaporedje črk lahko pomeni, da je bil določen del certificiran s strani navedenega pooblaščenega organa, v skladu z zakoni ali pravili seznama.

Mere so podane v milimetrih.

## sv - INSTRUKTIONER FÖR ANVÄNDNING

### 1 BESTÄLLA DELAR

Ange alltid reservdelsnummer, namn och antal delar som önskas, samt typbeteckning och tillverkningsnummer på maskinen.

Sidor markerade med servicesymbolen - "🔧" innehåller delar av servicesatser. Hela innehållet i satsen redovisas i kapitlet "1 - Service kits" (1 - Servicesatser).

### 2 SPALTINFORMATION

**Ref.** - Referensnummer: kopplar ihop en viss reservdel i förteckningen med ritningen. Endast reservdelar med referensnummer visas i ritningen. Reservdelar som saknar referensnummer i ritningen finns med för att illustrera själva monteringen.

**Part number** - Reservdelsnummer: om reservdelsnummer saknas finns komponenten inte som reservdel. Monteringsanvisningar visas med fet stil. En reservdel vars nummer följs av en svart punkt finns med i den fetstilta monteringsanvisningen direkt ovanför.

"<<< >>>" hänvisar till en annan lista med samma titel som "namnet".

När reservdelsnumret för den specifika delen är placerad nedanför "Ref."/"Namn"-raden måste ett val göras utifrån maskinens typ/version.

**Qty** - Antal: anger hur många delar som är kopplade till motsvarande referensnummer. "AR" betyder "As required" (som erfordras): antal eller nummer bestäms senare.

**Name** - Reservdelsbeteckningar: översättningar av de engelska beteckningarna återfinns i dokumentet "Glossary of part names" (Ordlista med reservdelsbeteckningar).

**Remarks** - Extrainformation om reservdelen.

En uppsättning bokstäver kan ange att en viss reservdel har certifierats av det befulldäktiga organet, enligt koderna eller reglerna i förteckningen.

Mått anges i millimeter.

## tr - KULLANIM TALİMATLARI

### 1 PARÇA SİPARİŞİ

Gerekli öğelerin parça numaraları, ad ve miktarının yanı sıra makinenin tip ve seri numarasını da mutlaka belirtin.

Servis simgesi - "🔧" taşıyan sayfalarda Servis kiti (kitleri) parçaları bulunmaktadır. Kitle ilgili tüm bilgilere ulaşmak için "1 - Service kits" (1 - Servis kitleri) bölümüne başvurun.

### 2 KOLON BİLGİLERİ

**Ref.** - Referans numarası: özel olarak listelenmiş bir parça için çizimden bağlantı sağlar. Sadece referans numarası olan parçalar çizimde gösterilir. Çizimde referans numarası bulunmayan parçalar sadece montaj işlemlerini göstermek için verilmiştir.

**Part number** - Parça numarası: parça numarası belirtilmemişse, bileşen yedek parça olarak bulunmamaktadır. Koyu harflerle gösterilen satır montajdır. Numarasından sonra siyah bir nokta gelen parça, yukarıda koyu harflerle basılmış montaja dahildir.

"<<< >>>", "Name" (Ad) ile aynı başlıkta bir başka listeye yönlendirir.

Belirli bir parçanın parça numarası "Ref."/"Name" (Ref./Ad) satırının altına yerleştirildiğinde, makine tipi/modeli konusunda seçim yapılmalıdır.

**Qty** - Miktar: uygun referans numarasıyla bağlantılı olarak parça sayısını gösterir. "AR", "As required" (Gerektiği gibi) anlamına gelmektedir: belirlenecek olan miktar veya sayı.

**Name** - Parça adı: İngilizce adların çevirileri, "Parça adları sözlüğü"nde bulunabilir.

**Remarks** - Açıklamalar: Parça hakkında ek bilgiler.

Bir dizi harf, belirli bir parçanın yasalara veya liste kurallarına uygun olarak özel yetkili bir makam tarafından sertifikalandırıldığını gösterebilir.

Ölçümler milimetre cinsinden verilmiştir.

## zh - 使用说明

### 1 订购零件

订购零件时必需指定零件号、零件名称、零件数量以及机器的类型和系列号。

在标有维修标记 "🔧" 的页面上有维修组件的部分内容。该组件的完整内容请参见章节 "1 - 维修组件" "1 - Service kits"。

### 2 每列内容的说明

**Ref.** - 图示编号：将零件清单中列出的零件与示意图中的该零件相关联。零件清单中仅显示有图示编号的零件。示意图中没有标注图示编号的零件仅用来在图中帮助示意。

**Part number** - 零件号：如果某项没有零件号，则该项不可作为零备件供应。以粗体印刷的零件号表示这是一个装置。编号后面有一个黑点的零件包含在其上面以粗体印刷的装置中。

"<<< >>>" 表示该装置的零件清单在手册中以同一名称另外分章单列。

如果指定的零件号位于 "Ref." (图示编号) "Name" (零件名称) 列上，则订购零件时必须指明机器的类型/版本。

**Qty** - 数量：显示相应的图示编号的零件个数。"AR" 表示 "As required"：即根据需要确定数量。

**Name** - 零件名称：在文件 "零件名称对照表" 中可以找到对应的英文名称。

**Remarks** - 零件的附注。

一连串的字母表示某一特定零件依照标准或规定的要求已获得指定授权机构的认证。



## Table of contents

1	Views of OGP 5.....	14
2	Views of OGP 45.....	15
3	Flow diagram OGP 2-105.....	16
4	Flow diagram OGP 160-200.....	17
5	Service kits.....	18
6	OGP 2, OGP 3.....	22
7	OGP 4, OGP 5.....	23
8	OGP 6, OGP 8.....	24
9	OGP 10, OGP 14.....	25
10	OGP 18, OGP 20, OGP 23.....	26
11	OGP 29, OGP 35.....	27
12	OGP 45, OGP 55, OGP 65.....	28
13	OGP 84.....	29
14	OGP 105.....	30
15	OGP 160.....	31
16	OGP 200.....	32



1

Views of OGP 5

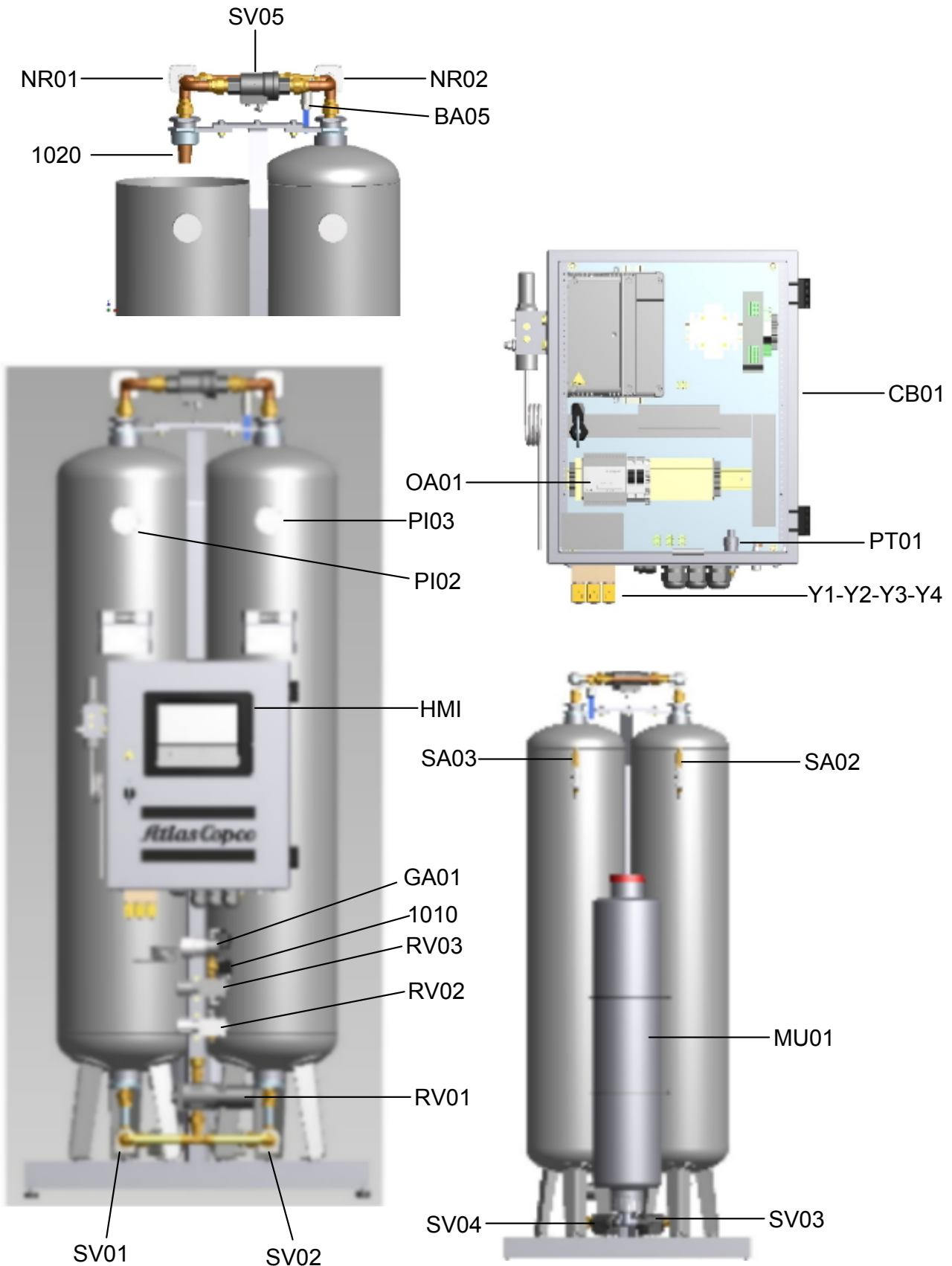

# Views of OGP 45

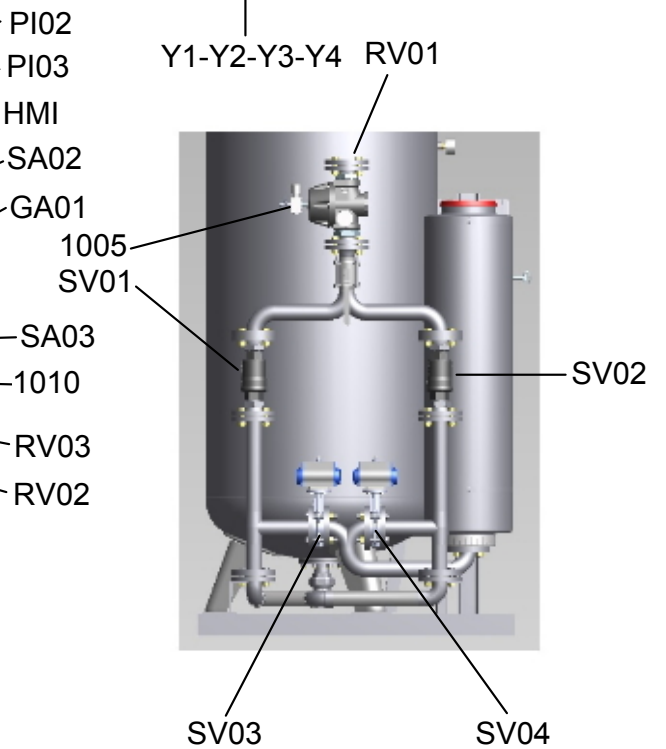
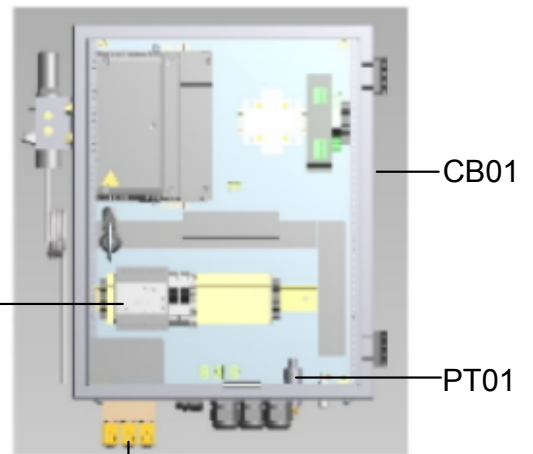
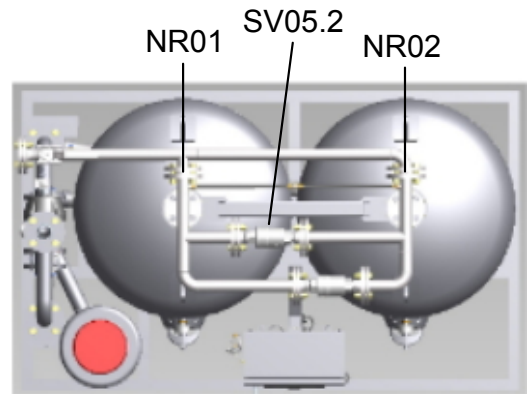
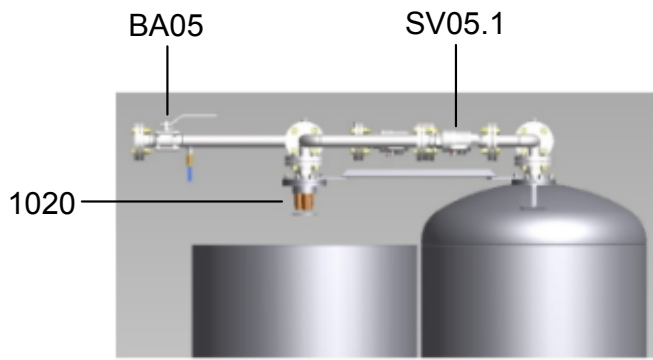

MU01

Flow diagram OGP 2-105

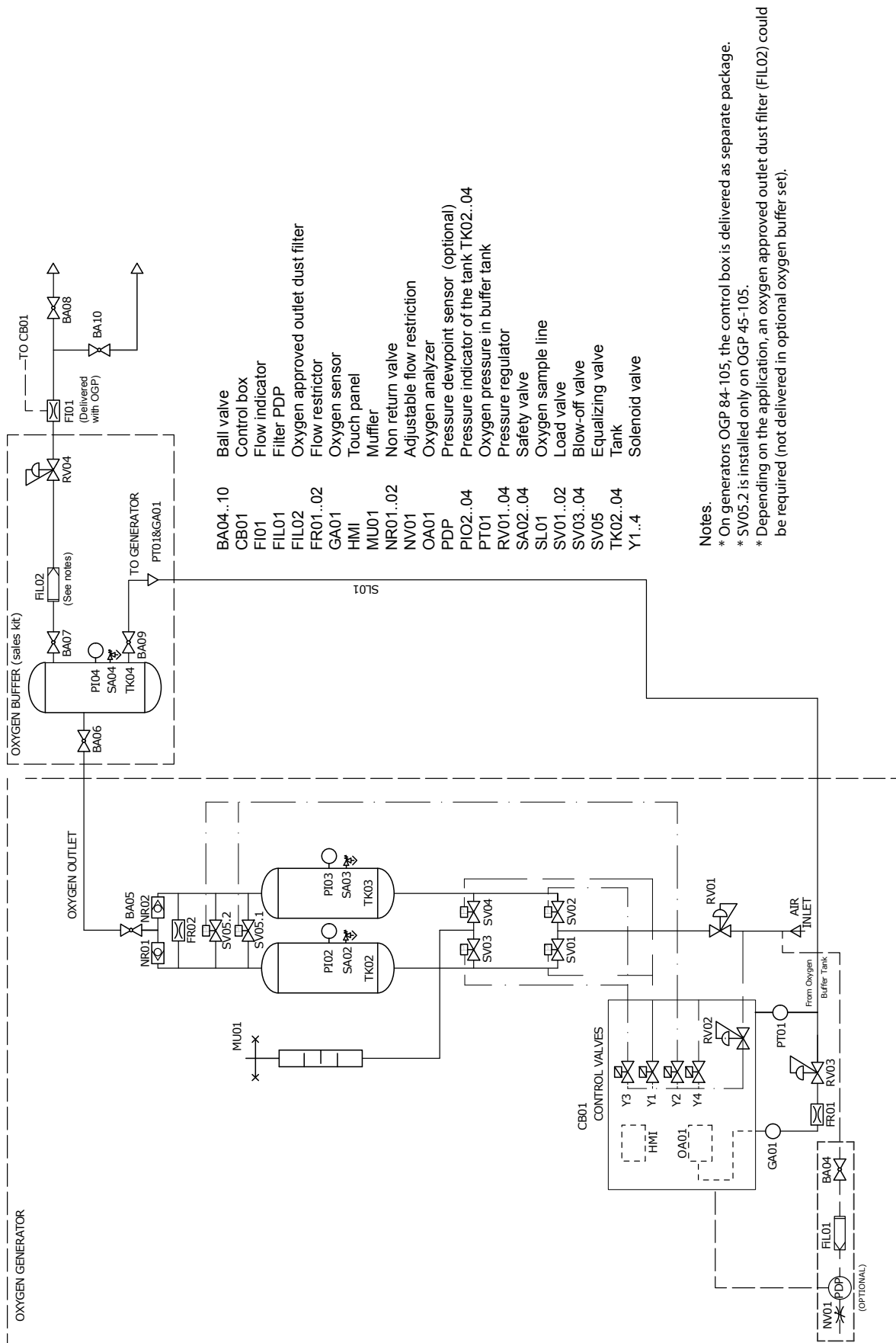



# Flow diagram OGP 160-200

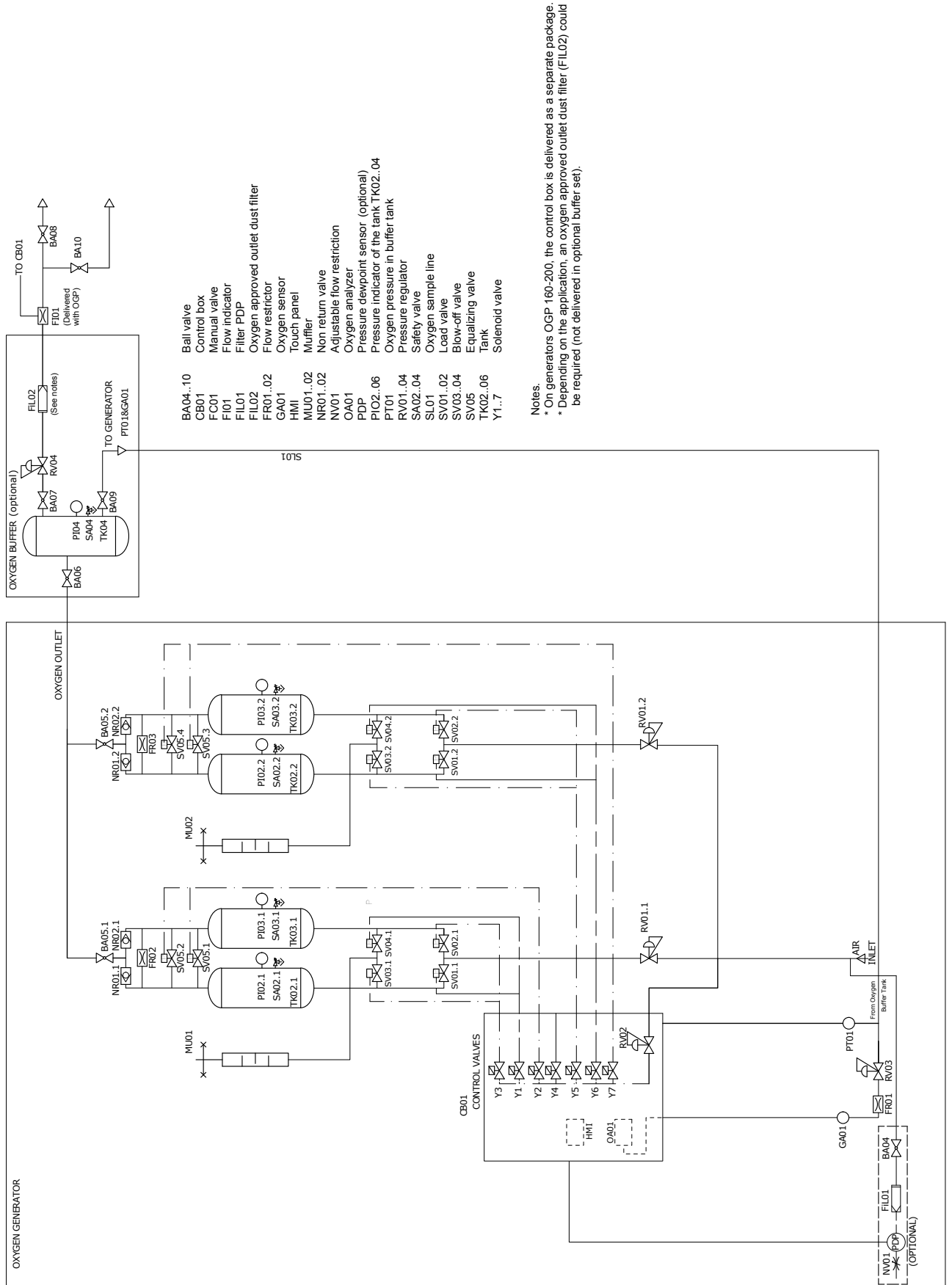

## 5

## Service kits

Ref.	Part number	Qty	Name	Remarks
<b>Service kit B &gt; 8000hrs or yearly</b>				
	<b>2904 5002 72</b>	1	<b>B-kit OGP 2, OGP 3</b>	8000hrs or yearly
SV05.1	0837 1500 67 •	1		Pneumatic valve equalization
	<b>2904 5002 74</b>	1	<b>B-kit OGP 4, OGP 5</b>	8000hrs or yearly
SV05.1	0837 1500 68 •	1		Pneumatic valve equalization
	<b>2904 5002 76</b>	1	<b>B-kit OGP 6, OGP 8</b>	8000hrs or yearly
SV05.1	0837 1500 68 •	2		Pneumatic valve equalization
	<b>2904 5002 78</b>	1	<b>B-kit OGP 10, OGP 14</b>	8000hrs or yearly
SV05.1	0837 1500 69 •	1		Pneumatic valve equalization
	<b>2904 5002 80</b>	1	<b>B-kit OGP 18, OGP 20, OG 23</b>	8000hrs or yearly
SV05.1	0837 1500 70 •	1		Pneumatic valve equalization
	<b>2904 5002 82</b>	1	<b>B-kit OGP 29, OGP 35</b>	8000hrs or yearly
SV05.1	0837 1500 71 •	1		Pneumatic valve equalization
	<b>2904 5002 84</b>	1	<b>B-kit OGP 45, OGP 55, OGP 65</b>	8000hrs or yearly
SV05.1-SV05.2	0837 1500 71 •	2		Pneumatic valve equalization
	<b>2904 5002 86</b>	1	<b>B-kit OGP 84</b>	8000hrs or yearly
SV05.1-SV05.2	0837 1500 71 •	2		Pneumatic valve equalization
	<b>2904 5002 88</b>	1	<b>B-kit OGP 105</b>	8000hrs or yearly
SV05.1-SV05.2	0837 1500 71 •	2		Pneumatic valve equalization
	<b>2904 5002 90</b>	1	<b>B-kit OGP 160</b>	8000hrs or yearly
SV05.1-SV05.2-SV05.3-SV05.4	0837 1500 71 •	4		Pneumatic valve equalization
	<b>2904 5003 01</b>	1	<b>B-kit OGP 200</b>	8000hrs or yearly
SV05.1-SV05.2-SV05.3-SV05.4	0837 1500 71 •	4		Pneumatic valve equalization

## Service kits

5

Ref.	Part number	Qty	Name	Remarks
<b>Service kit C &gt; 16000hrs or 2-yearly</b>				
	<b>2904 5002 73</b>	<b>1</b>	<b>C-kit OGP 2, OGP 3</b>	16000hrs or 2-yearly
SV01-SV02	0837 1500 67 •	2	Pneumatic valve air inlet	
SV03-SV04	0837 1500 82 •	2	Pneumatic valve exhaust/blow off	
-	2904 5002 72 •	1	Service kit B	
	<b>2904 5002 75</b>	<b>1</b>	<b>C-kit OGP 4, OGP 5</b>	16000hrs or 2-yearly
SV01-SV02	0837 1500 82 •	1	Pneumatic valve air inlet	
SV03-SV04	0837 1500 82 •	2	Pneumatic valve exhaust/blow off	
-	2904 5002 74 •	1	Service kit B	
	<b>2904 5002 77</b>	<b>1</b>	<b>C-kit OGP 6, OGP 8</b>	16000hrs or 2-yearly
SV01-SV02	0837 1500 82 •	1	Pneumatic valve air inlet	
SV03-SV04	0837 1500 68 •	2	Pneumatic valve exhaust/blow off	
-	2904 5002 76 •	1	Service kit B	
	<b>2904 5002 79</b>	<b>1</b>	<b>C-kit OGP 10, OGP 14</b>	16000hrs or 2-yearly
SV01-SV02	0837 1500 68 •	2	Pneumatic valve air inlet	
SV03-SV04	0837 1500 69 •	2	Pneumatic valve exhaust/blow off	
-	2904 5002 78 •	1	Service kit B	
	<b>2904 5002 81</b>	<b>1</b>	<b>C-kit OGP 18, OGP 20, OGP 23</b>	16000hrs or 2-yearly
SV01-SV02	0837 1500 69 •	2	Pneumatic valve air inlet	
SV03-SV04	0837 1500 70 •	2	Pneumatic valve exhaust/blow off	
-	2904 5002 80 •	1	Service kit B	
	<b>2904 5002 83</b>	<b>1</b>	<b>C-kit OGP 29, OGP 35</b>	16000hrs or 2-yearly
SV01-SV02	0837 1500 70 •	2	Pneumatic valve air inlet	
SV03-SV04	0837 1500 71 •	2	Pneumatic valve exhaust/blow off	
-	2904 5002 82 •	1	Service kit B	
	<b>2904 5002 85</b>	<b>1</b>	<b>C-kit OGP 45, OGP 55, OGP 65</b>	16000hrs or 2-yearly
SV01-SV02	0837 1500 71 •	2	Pneumatic valve air inlet	
SV03-SV04	1629 0951 27 •	2	Butterfly valve with actuator exhaust/blow off	
-	2904 5002 84 •	1	Service kit B	
	<b>2904 5002 87</b>	<b>1</b>	<b>C-kit OGP 84</b>	16000hrs or 2-yearly
SV01-SV02	0837 1500 71 •	2	Pneumatic valve air inlet	
SV03-SV04	1629 0950 38 •	2	Butterfly valve with actuator exhaust/blow off	
-	2904 5002 86 •	1	Service kit B	

## 5

## Service kits

Ref.	Part number	Qty	Name	Remarks
	<b>2904 5002 89</b>	<b>1</b>	<b>C-kit OGP 105</b>	16000hrs or 2-yearly
SV01-SV02	0837 1500 71 •	2	Pneumatic valve air inlet	
SV03-SV04	1629 0951 28 •	2	Butterfly valve with actuator exhaust/blow off	
-	2904 5002 88 •	1	Service kit B	
	<b>2904 5003 00</b>	<b>1</b>	<b>C-kit OGP 160</b>	16000hrs or 2-yearly
SV01.1-SV01.2-SV02.1-SV02.2	0837 1500 71 •	4	Pneumatic valve air inlet	
SV03.1-SV03.2-SV04.1-SV04.2	1629 0950 38 •	4	Butterfly valve with actuator exhaust/blow off	
-	2904 5002 90 •	1	Service kit B	
	<b>2904 5003 02</b>	<b>1</b>	<b>C-kit OGP 200</b>	16000hrs or 2-yearly
SV01.1-SV01.2-SV02.1-SV02.2	0837 1500 71 •	4	Pneumatic valve air inlet	
SV03.1-SV03.2-SV04.1-SV04.2	1629 0951 28 •	4	Butterfly valve with actuator exhaust/blow off	
-	2904 5003 01 •	1	Service kit B	
<b>Service kit D &gt; 40000hrs or 5-yearly</b>				
	<b>2904 5002 93</b>	<b>1</b>	<b>D-kit OGP zirconia sensor</b>	40000hrs or 5-yearly
GA01	1629 0950 93 •	1	Oxygen sensor	
OA01	1627 6327 00 •	1	Oxygen analyzer	
	9740 2021 11 •	1	Fitting	
	0603 4100 13 •	1	Fitting	



## 6

## OGP 2, OGP 3

Ref.	Part number	Qty	Name	Remarks
BA05	0852 0011 65	1	Outlet ball valve	
<b>CB01</b>		<b>1</b>	<b>Control box assembly</b>	
	<b>1900 5025 01</b>		IEC	
	<b>1900 5025 03</b>		UL-cUL	
HMI		• 1	Controller	
	1900 5200 90		Elektronikon® Mk5 Graphic	
Y1-Y2-Y3-Y4	1089 9441 10	• 1	Solenoid valve block	
-	1624 8443 00	• 1	Wire harness	
-	1625 6289 00	• 1	Wiring CAN connector	
-	1089 9413 56	• 1	Contactator	
-	1089 9544 20	• 1	Power supply 24VDC	
-	1089 9514 67	• 1	Transformer	
-		• 1	Circuit breaker	
	1089 9526 08		1900 5025 01	
-	1900 5200 41	• 1	Expansion module	
-	1088 0021 12	• 1	Connector	M12
-	1622 5099 03	• 1	Cable I/O	
FI01	1089 0713 30	1	Flow sensor	
NR01-NR02	0837 1500 53	2	Non-return valve	
PT01	1089 9579 10	1	Pressure transmitter oxygen	
RV01	0837 1500 39	1	Pressure regulator	
RV02	0837 1500 47	1	Pressure regulator control valve	
RV03	0837 1500 90	1	Pressure regulator gas analyzer	
SV01-SV02	0837 1500 67	2	Pneumatic valve air inlet	
SV03-SV04	0837 1500 82	2	Pneumatic valve exhaust/blow off	
SV05	0837 1500 67	1	Pneumatic valve equalization	
SA02-SA03	1629 0951 23	1	Safety valve	
PI02-PI03	1629 0950 18	1	Pressure gauge	
MU01	1629 0900 14	1	Exhaust pipe	
1010	1089 0380 39	1	Cut-off (solenoid) valve	
1020	1629 0950 03	2	Sintered brass top silencer	
-	1629 0907 80	1	Bottom connection	
-	1629 0900 89	1	Top connection	
	<b>2904 5002 93</b>	<b>1</b>	<b>Kit OGP zirconia sensor</b>	
GA01		• 1	Sensor multi function	
OA01		• 1	Oxygen analyzer	

## OGP 4, OGP 5

7

Ref.	Part number	Qty	Name	Remarks
BA05	0852 0011 65	1	Outlet ball valve	
<b>CB01</b>		<b>1</b>	<b>Control box assembly</b>	
	<b>1900 5025 01</b>		IEC	
	<b>1900 5025 03</b>		UL-cUL	
HMI		• 1	Controller	
	1900 5200 90		Elektronikon® Mk5 Graphic	
Y1-Y2-Y3-Y4	1089 9441 10	• 1	Solenoid valve block	
-	1624 8443 00	• 1	Wire harness	
-	1625 6289 00	• 1	Wiring CAN connector	
-	1089 9413 56	• 1	Contactora	
-	1089 9544 20	• 1	Power supply 24VDC	
-	1089 9514 67	• 1	Transformer	
-		• 1	Circuit breaker	
	1089 9526 08		1900 5025 01	
-	1900 5200 41	• 1	Expansion module	
-	1088 0021 12	• 1	Connector	M12
-	1622 5099 03	• 1	Cable I/O	
FI01	1089 0713 30	1	Flow sensor	
NR01-NR02	0837 1500 53	2	Non-return valve	
PT01	1089 9579 10	1	Pressure transmitter oxygen	
RV01	0837 1500 39	1	Pressure regulator	
RV02	0837 1500 47	1	Pressure regulator control valve	
RV03	0837 1500 90	1	Pressure regulator gas analyzer	
SV01-SV02	0837 1500 82	2	Pneumatic valve air inlet	
SV03-SV04	0837 1500 82	2	Pneumatic valve exhaust/blow off	
SV05	0837 1500 68	1	Pneumatic valve equalization	
SA02-SA03	1629 0951 23	1	Safety valve	
PI02-PI03	1629 0950 18	1	Pressure gauge	
MU01	1629 0900 14	1	Exhaust pipe	
1010	1089 0380 39	1	Cut-off (solenoid) valve	
1020	1629 0950 03	2	Sintered brass top silencer	
-	1629 0907 86	1	Bottom connection	
-	1629 0900 82	1	Top connection	
	<b>2904 5002 93</b>	<b>1</b>	<b>Kit OGP zirconia sensor</b>	
GA01		• 1	Sensor multi function	
OA01		• 1	Oxygen analyzer	

Ref.	Part number	Qty	Name	Remarks
BA05	0852 0011 65	1	Outlet ball valve	
<b>CB01</b>		<b>1</b>	<b>Control box assembly</b>	
	<b>1900 5025 01</b>		IEC	
	<b>1900 5025 03</b>		UL-cUL	
HMI		• 1	Controller	
	1900 5200 90		Elektronikon® Mk5 Graphic	
Y1-Y2-Y3-Y4	1089 9441 10	• 1	Solenoid valve block	
-	1624 8443 00	• 1	Wire harness	
-	1625 6289 00	• 1	Wiring CAN connector	
-	1089 9413 56	• 1	Contactator	
-	1089 9544 20	• 1	Power supply 24VDC	
-	1089 9514 67	• 1	Transformer	
-		• 1	Circuit breaker	
	1089 9526 08		1900 5025 01	
-	1900 5200 41	• 1	Expansion module	
-	1088 0021 12	• 1	Connector	M12
-	1622 5099 03	• 1	Cable I/O	
FI01	1089 0713 08	1	Flow sensor	
NR01-NR02	0837 1500 53	2	Non-return valve	
PT01	1089 9579 10	1	Pressure transmitter oxygen	
RV01	0837 1500 39	1	Pressure regulator	
RV02	0837 1500 47	1	Pressure regulator control valve	
RV03	0837 1500 90	1	Pressure regulator gas analyzer	
SV01-SV02	0837 1500 82	2	Pneumatic valve air inlet	
SV03-SV04	0837 1500 68	2	Pneumatic valve exhaust/blow off	
SV05	0837 1500 68	1	Pneumatic valve equalization	
SA02-SA03	1629 0951 23	1	Safety valve	
PI02-PI03	1629 0950 18	1	Pressure gauge	
MU01	1629 0900 14	1	Exhaust pipe	
1010	1089 0380 39	1	Cut-off (solenoid) valve	
1020	1629 0950 03	2	Sintered brass top silencer	
-	1629 0907 88	1	Bottom connection	
-	1629 0904 81	1	Top connection	
	<b>2904 5002 93</b>	<b>1</b>	<b>Kit OGP zirconia sensor</b>	
GA01		• 1	Sensor multi function	
OA01		• 1	Oxygen analyzer	



## OGP 10, OGP 14

9

Ref.	Part number	Qty	Name	Remarks
BA05	0852 0011 66	1	Outlet ball valve	
<b>CB01</b>		<b>1</b>	<b>Control box assembly</b>	
	<b>1900 5025 01</b>		IEC	
	<b>1900 5025 03</b>		UL-cUL	
HMI		• 1	Controller	
	1900 5200 90		Elektronikon® Mk5 Graphic	
Y1-Y2-Y3-Y4	1089 9441 10	• 1	Solenoid valve block	
-	1624 8443 00	• 1	Wire harness	
-	1625 6289 00	• 1	Wiring CAN connector	
-	1089 9413 56	• 1	Contacto	
-	1089 9544 20	• 1	Power supply 24VDC	
-	1089 9514 67	• 1	Transformer	
-		• 1	Circuit breaker	
	1089 9526 08		1900 5025 01	
-	1900 5200 41	• 1	Expansion module	
-	1088 0021 12	• 1	Connector	M12
-	1622 5099 03	• 1	Cable I/O	
FI01	1089 0713 08	1	Flow sensor	
NR01-NR02	0837 1500 55	2	Non-return valve	
PT01	1089 9579 10	1	Pressure transmitter oxygen	
RV01	0837 1500 50	1	Pressure regulator	
RV02	0837 1500 47	1	Pressure regulator control valve	
RV03	0837 1500 90	1	Pressure regulator gas analyzer	
SV01-SV02	0837 1500 68	2	Pneumatic valve air inlet	
SV03-SV04	0837 1500 69	2	Pneumatic valve exhaust/blow off	
SV05	0837 1500 69	1	Pneumatic valve equalization	
SA02-SA03	1629 0951 23	1	Safety valve	
PI02-PI03	1629 0950 18	1	Pressure gauge	
MU01	1629 0900 14	1	Exhaust pipe	
1010	1089 0380 39	1	Cut-off (solenoid) valve	
1020	1629 0950 03	2	Sintered brass top silencer	
-	1629 0905 88	1	Bottom connection	
-	1629 0905 87	1	Top connection	
	<b>2904 5002 93</b>	<b>1</b>	<b>Kit OGP zirconia sensor</b>	
GA01		• 1	Sensor multi function	
OA01		• 1	Oxygen analyzer	

## 10

## OGP 18, OGP 20, OGP 23

Ref.	Part number	Qty	Name	Remarks
BA05	0852 0011 66	1	Outlet ball valve	
<b>CB01</b>		<b>1</b>	<b>Control box assembly</b>	
	<b>1900 5025 01</b>		IEC	
	<b>1900 5025 03</b>		UL-cUL	
HMI		• 1	Controller	
	1900 5200 90		Elektronikon® Mk5 Graphic	
Y1-Y2-Y3-Y4	1089 9441 10	• 1	Solenoid valve block	
-	1624 8443 00	• 1	Wire harness	
-	1625 6289 00	• 1	Wiring CAN connector	
-	1089 9413 56	• 1	Contactator	
-	1089 9544 20	• 1	Power supply 24VDC	
-	1089 9514 67	• 1	Transformer	
-		• 1	Circuit breaker	
	1089 9526 08		1900 5025 01	
-	1900 5200 41	• 1	Expansion module	
-	1088 0021 12	• 1	Connector	M12
-	1622 5099 03	• 1	Cable I/O	
FI01	1089 0713 08	1	Flow sensor	
NR01-NR02	0837 1500 55	2	Non-return valve	
PT01	1089 9579 10	1	Pressure transmitter oxygen	
RV01	0837 1500 50	1	Pressure regulator	
RV02	0837 1500 47	1	Pressure regulator control valve	
RV03	0837 1500 90	1	Pressure regulator gas analyzer	
SV01-SV02	0837 1500 69	2	Pneumatic valve air inlet	
SV03-SV04	0837 1500 70	2	Pneumatic valve exhaust/blow off	
SV05	0837 1500 70	1	Pneumatic valve equalization	
SA02-SA03	1629 0951 23	1	Safety valve	
PI02-PI03	1629 0950 18	1	Pressure gauge	
MU01	1629 0900 68	1	Exhaust pipe	
1010	1089 0380 39	1	Cut-off (solenoid) valve	
1020	1629 0950 03	2	Sintered brass top silencer	
-	1629 0907 83	1	Bottom connection	
-	1629 0901 85	1	Top connection	
	<b>2904 5002 93</b>	<b>1</b>	<b>Kit OGP zirconia sensor</b>	
GA01		• 1	Sensor multi function	
OA01		• 1	Oxygen analyzer	

## OGP 29, OGP 35

11

Ref.	Part number	Qty	Name	Remarks
BA05	0852 0011 67	1	Outlet ball valve	
<b>CB01</b>		<b>1</b>	<b>Control box assembly</b>	
	<b>1900 5025 01</b>		IEC	
	<b>1900 5025 03</b>		UL-cUL	
HMI		• 1	Controller	
	1900 5200 90		Elektronikon® Mk5 Graphic	
Y1-Y2-Y3-Y4	1089 9441 10	• 1	Solenoid valve block	
-	1624 8443 00	• 1	Wire harness	
-	1625 6289 00	• 1	Wiring CAN connector	
-	1089 9413 56	• 1	Contacto	
-	1089 9544 20	• 1	Power supply 24VDC	
-	1089 9514 67	• 1	Transformer	
-		• 1	Circuit breaker	
	1089 9526 08		1900 5025 01	
-	1900 5200 41	• 1	Expansion module	
-	1088 0021 12	• 1	Connector	M12
-	1622 5099 03	• 1	Cable I/O	
FI01	1089 0713 08	1	Flow sensor	
NR01-NR02	0837 1500 55	2	Non-return valve	
PT01	1089 9579 10	1	Pressure transmitter oxygen	
RV01	0837 1500 51	1	Pressure regulator	
RV02	0837 1500 47	1	Pressure regulator control valve	
RV03	0837 1500 90	1	Pressure regulator gas analyzer	
SV01-SV02	0837 1500 70	2	Pneumatic valve air inlet	
SV03-SV04	0837 1500 71	2	Pneumatic valve exhaust/blow off	
SV05	0837 1500 71	1	Pneumatic valve equalization	
SA02-SA03	1629 0951 23	1	Safety valve	
PI02-PI03	1629 0950 18	1	Pressure gauge	
MU01	1629 0901 30	1	Exhaust pipe	
1010	1089 0380 39	1	Cut-off (solenoid) valve	
1020	1629 0950 03	8	Sintered brass top silencer	
-	1629 0904 89	1	Bottom connection	
-	1629 0903 81	1	Top connection	
	<b>2904 5002 93</b>	<b>1</b>	<b>Kit OGP zirconia sensor</b>	
GA01		• 1	Sensor multi function	
OA01		• 1	Oxygen analyzer	

## 12

## OGP 45, OGP 55, OGP 65

Ref.	Part number	Qty	Name	Remarks
BA05	0852 0011 73	1	Outlet ball valve	
<b>CB01</b>		<b>1</b>	<b>Control box assembly</b>	
	<b>1900 5025 01</b>		IEC	
	<b>1900 5025 03</b>		UL-cUL	
HMI		• 1	Controller	
	1900 5200 90		Elektronikon® Mk5 Graphic	
Y1-Y2-Y3-Y4	1089 9441 10	• 1	Solenoid valve block	
-	1624 8443 00	• 1	Wire harness	
-	1625 6289 00	• 1	Wiring CAN connector	
-	1089 9413 56	• 1	Contactator	
-	1089 9544 20	• 1	Power supply 24VDC	
-	1089 9514 67	• 1	Transformer	
-		• 1	Circuit breaker	
	1089 9526 08		1900 5025 01	
-	1900 5200 41	• 1	Expansion module	
-	1088 0021 12	• 1	Connector	M12
-	1622 5099 03	• 1	Cable I/O	
FI01		1	Flow sensor	
	1089 0713 08		OGP 45	
	1089 0713 08		OGP 55	
	1089 0713 26		OGP 65	
NR01-NR02	0823 0090 49	2	Non-return valve	
PT01	1089 9579 10	1	Pressure transmitter oxygen	
RV01	0837 1500 79	1	Pressure regulator	
1005	0837 1500 47	1	Control regulator for RV01	
RV02	0837 1500 47	1	Pressure regulator control valve	
RV03	0837 1500 90	1	Pressure regulator gas analyzer	
SV01-SV02	0837 1500 71	2	Pneumatic valve air inlet	
SV03-SV04	1629 0951 27	2	Butterfly valve with actuator exhaust/blow off	
SV05.1-SV05.2	0837 1500 70	2	Pneumatic valve equalization	
SA02-SA03	1629 0951 23	1	Safety valve	
PI02-PI03	1629 0950 18	1	Pressure gauge	
MU01	1629 0902 54	1	Exhaust pipe	
1010	1089 0380 39	1	Cut-off (solenoid) valve	
1020	1629 0950 03	8	Sintered brass top silencer	
-	1629 0912 86	1	Bottom connection	
-	1629 0912 87	1	Top connection	
	<b>2904 5002 93</b>	<b>1</b>	<b>Kit OGP zirconia sensor</b>	
GA01		• 1	Sensor multi function	
OA01		• 1	Oxygen analyzer	

## OGP 84

13

Ref.	Part number	Qty	Name	Remarks
BA05	0852 0011 75	1	Outlet ball valve	
<b>CB01</b>		<b>1</b>	<b>Control box assembly</b>	
	<b>1900 5025 01</b>		IEC	
	<b>1900 5025 03</b>		UL-cUL	
HMI		• 1	Controller	
	1900 5200 90		Elektronikon® Mk5 Graphic	
Y1-Y2-Y3-Y4	1089 9441 10	• 1	Solenoid valve block	
-	1624 8443 00	• 1	Wire harness	
-	1625 6289 00	• 1	Wiring CAN connector	
-	1089 9413 56	• 1	Contacto	
-	1089 9544 20	• 1	Power supply 24VDC	
-	1089 9514 67	• 1	Transformer	
-		• 1	Circuit breaker	
	1089 9526 08		1900 5025 01	
-	1900 5200 41	• 1	Expansion module	
-	1088 0021 12	• 1	Connector	M12
-	1622 5099 03	• 1	Cable I/O	
FI01	1089 0713 26	1	Flow sensor	
NR01-NR02	0823 0090 48	2	Non-return valve	
PT01	1089 9579 09	1	Pressure transmitter oxygen	
RV02	0837 1500 47	1	Pressure regulator control valve	
RV03	0837 1500 90	1	Pressure regulator gas analyzer	
SV01-SV02	0837 1500 71	2	Pneumatic valve air inlet	
SV03-SV04	1629 0950 38	2	Butterfly valve with actuator exhaust/blow off	
SV05.1-SV05.2	0837 1500 71	2	Pneumatic valve equalization	
SA02-SA03	1629 0951 23	1	Safety valve	
PI02-PI03	1629 0950 18	1	Pressure gauge	
MU01	1629 0902 34	1	Exhaust pipe	
1010	1089 0380 39	1	Cut-off (solenoid) valve	
1020	1629 0950 03	8	Sintered brass top silencer	
-	1629 0912 81	1	Bottom connection	
-	1629 0912 82	1	Top connection	
	<b>2904 5002 93</b>	<b>1</b>	<b>Kit OGP zirconia sensor</b>	
GA01		• 1	Sensor multi function	
OA01		• 1	Oxygen analyzer	

14

OGP 105

Ref.	Part number	Qty	Name	Remarks
BA05	1629 0951 25	1	Outlet ball valve	
<b>CB01</b>		<b>1</b>	<b>Control box assembly</b>	
	<b>1900 5025 01</b>		IEC	
	<b>1900 5025 03</b>		UL-cUL	
HMI		• 1	Controller	
	1900 5200 90		Elektronikon® Mk5 Graphic	
Y1-Y2-Y3-Y4	1089 9441 10	• 1	Solenoid valve block	
-	1624 8443 00	• 1	Wire harness	
-	1625 6289 00	• 1	Wiring CAN connector	
-	1089 9413 56	• 1	Contacteur	
-	1089 9544 20	• 1	Power supply 24VDC	
-	1089 9514 67	• 1	Transformer	
-		• 1	Circuit breaker	
	1089 9526 08		1900 5025 01	
-	1900 5200 41	• 1	Expansion module	
-	1088 0021 12	• 1	Connector	M12
-	1622 5099 03	• 1	Cable I/O	
FI01	1089 0713 26	1	Flow sensor	
NR01-NR02	0823 0090 48	2	Non-return valve	
PT01	1089 9579 10	1	Pressure transmitter oxygen	
RV02	0837 1500 47	1	Pressure regulator control valve	
RV03	0837 1500 90	1	Pressure regulator gas analyzer	
SV01-SV02	0837 1500 71	2	Pneumatic valve air inlet	
SV03-SV04	1629 0951 28	2	Butterfly valve with actuator exhaust/blow off	
SV05.1-SV05.2	0837 1500 71	2	Pneumatic valve equalization	
SA02-SA03	1629 0951 23	1	Safety valve	
PI02-PI03	1629 0950 06	1	Pressure gauge	
MU01	1629 0902 34	1	Exhaust pipe	
1010	1089 0380 39	1	Cut-off (solenoid) valve	
1020	1629 0950 03	8	Sintered brass top silencer	
-	1629 0906 87	1	Bottom connection	
-	1629 0906 85	1	Top connection	
	<b>2904 5002 93</b>	<b>1</b>	<b>Kit OGP zirconia sensor</b>	
GA01		• 1	Sensor multi function	
OA01		• 1	Oxygen analyzer	

## OGP 160

15

Ref.	Part number	Qty	Name	Remarks
BA05	0852 0011 75	2	Outlet ball valve	
<b>CB01</b>		<b>1</b>	<b>Control box assembly</b>	
	<b>1900 5025 11</b>		IEC	
	<b>1900 5025 13</b>		UL-cUL	
HMI		• 1	Controller	
	1900 5200 90		Elektronikon® Mk5 Graphic	
Y1-Y2-Y3-Y4-Y5-Y6				
	1089 9441 11	• 1	Solenoid valve block	
-	1624 8446 00	• 1	Wire harness	
-	1625 6289 00	• 1	Wiring CAN connector	
-	1089 9413 56	• 1	Contacto	
-	1089 9544 20	• 1	Power supply 24VDC	
-	1089 9514 35	• 1	Transformer	
-		• 1	Circuit breaker	
	1089 9526 08		1900 5025 11	
-	1900 5200 41	• 1	Expansion module IO34	
-	1900 5200 95	• 1	Expansion module IO2	
-	1088 0021 12	• 1	Connector	M12
-	1622 5099 03	• 2	Cable I/O	
FI01	1089 0713 27	1	Flow sensor	
NR01.1-NR01.2-NR02.1-NR02.2				
	0823 0090 48	4	Non-return valve	
PT01	1089 9579 10	1	Pressure transmitter oxygen	
RV02	0837 1500 47	1	Pressure regulator control valve	
RV03	0837 1500 90	1	Pressure regulator gas analyzer	
SV01.1-SV01.2-SV02.1-SV02.2				
	0837 1500 71	4	Pneumatic valve air inlet	
SV03.1-SV03.2-SV04.1-SV04.2				
	1629 0950 38	4	Butterfly valve with actuator exhaust/blow off	
SV05.1-SV05.2-SV05.3-SV05.4				
	0837 1500 71	4	Pneumatic valve equalization	
SA02-SA03	1629 0950 05	1	Safety valve	
PI02-PI03	1629 0950 06	1	Pressure gauge	
MU01	1629 0902 34	1	Exhaust pipe	
1010	1089 0380 39	1	Cut-off (solenoid) valve	
1020	1629 0950 03	16	Sintered brass top silencer	
-	1629 0912 81	2	Bottom connection	
-	1629 0912 82	2	Top connection	
	<b>2904 5002 93</b>	<b>1</b>	<b>Kit OGP zirconia sensor</b>	
GA01		• 1	Sensor multi function	
OA01		• 1	Oxygen analyzer	

Ref.	Part number	Qty	Name	Remarks
BA05	1629 0951 25	2	Outlet ball valve	
<b>CB01</b>		<b>1</b>	<b>Control box assembly</b>	
	<b>1900 5025 11</b>		IEC	
	<b>1900 5025 13</b>		UL-cUL	
HMI	1900 5200 90	• 1	Controller Elektronikon® Mk5 Graphic	
Y1-Y2-Y3-Y4-Y5-Y6				
	1089 9441 11	• 1	Solenoid valve block	
-	1624 8446 00	• 1	Wire harness	
-	1625 6289 00	• 1	Wiring CAN connector	
-	1089 9413 56	• 1	Contactator	
-	1089 9544 20	• 1	Power supply 24VDC	
-	1089 9514 35	• 1	Transformer	
-		• 1	Circuit breaker	
	1089 9526 08		1900 5025 11	
-	1900 5200 41	• 1	Expansion module IO34	
-	1900 5200 95	• 1	Expansion module IO2	
-	1088 0021 12	• 1	Connector	M12
-	1622 5099 03	• 2	Cable I/O	
FI01	1089 0713 27	1	Flow sensor	
NR01.1-NR01.2-NR02.1-NR02.2				
	0823 0090 48	4	Non-return valve	
PT01	1089 9579 10	1	Pressure transmitter oxygen	
RV02	0837 1500 47	1	Pressure regulator control valve	
RV03	0837 1500 90	1	Pressure regulator gas analyzer	
SV01.1-SV01.2-SV02.1-SV02.2				
	0837 1500 71	4	Pneumatic valve air inlet	
SV03.1-SV03.2-SV04.1-SV04.2				
	1629 0951 28	4	Butterfly valve with actuator exhaust/blow off	
SV05.1-SV05.2-SV05.3-SV05.4				
	0837 1500 71	4	Pneumatic valve equalization	
SA02-SA03	1629 0951 23	1	Safety valve	
PI02-PI03	1629 0950 06	1	Pressure gauge	
MU01	1629 0902 34	1	Exhaust pipe	
1010	1089 0380 39	1	Cut-off (solenoid) valve	
1020	1629 0950 03	16	Sintered brass top silencer	
-	1629 0906 87	2	Bottom connection	
-	1629 0906 85	2	Top connection	
	<b>2904 5002 93</b>	<b>1</b>	<b>Kit OGP zirconia sensor</b>	
GA01		• 1	Sensor multi function	
OA01		• 1	Oxygen analyzer	









## ***COMMITTED TO SUSTAINABLE PRODUCTIVITY***

We stand by our responsibilities towards our customers, towards the environment and the people around us. We make performance stand the test of time. This is what we call - Sustainable Productivity.

[www.atlascopco.com](http://www.atlascopco.com)