

# Panel installation

for extensible GAE630 panels

ASSEMBLY INSTRUCTIONS

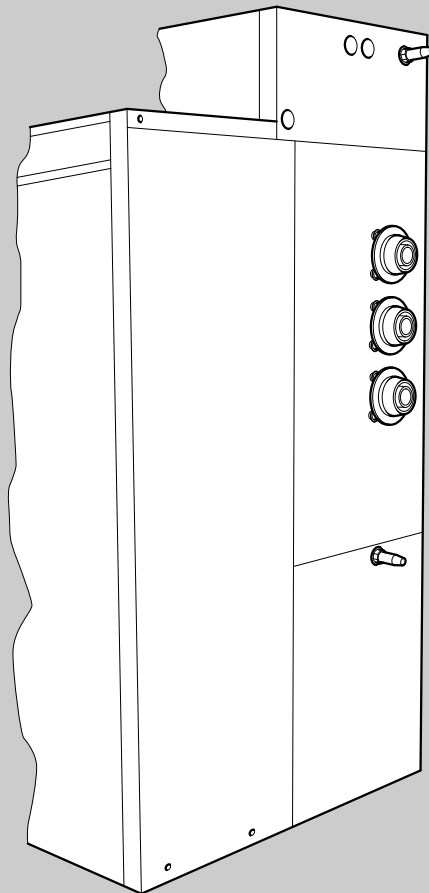



# Table of contents

- 1 General ..... 4**
  - 1.1 Liability and warranty ..... 4
  - 1.2 Service information ..... 4
  
- 2 Safety regulations ..... 5**
  - 2.1 Explanation of symbols and notes ..... 5
  - 2.2 General notes on safety ..... 5
    - 2.2.1 Assembly ..... 6
    - 2.2.2 Safety installations ..... 6
    - 2.2.3 Auxiliary assembly devices ..... 6
    - 2.2.4 Statutory accident prevention instructions .... 6
  
- 3 Assembly accessories ..... 7**
  - 3.1 Panel types ..... 7
  - 3.2 Assembly components ..... 8
    - 3.2.1 Standard-accessories kit ..... 8
    - 3.2.2 End panel (Assembly kit 6) ..... 9
    - 3.2.3 Busbar covering sheet for  
cable connection compartment ..... 10
    - 3.2.4 Panel installation ..... 12
  - 3.3 Assembly tools ..... 13
  
- 4 Assembly sequence ..... 14**
  - 4.1 Left-hand end panel ..... 14
  - 4.2 Panel installation GAE630-Standard  
with GAE630-Standard ..... 21
  - 4.3 Right hand end panel ..... 31
  - 4.4 Cable connection technology ..... 31
  
- 5 Tightening torques ..... 32**
  
- 6 Accessories ..... 33**

# 1 General

## 1.1 Liability and warranty

All information and notes concerning the assembly of panel installations and of the end panel are provided under due consideration of our present experience and to the best of our knowledge.

These assembly instructions describe the assembly of panel installations and end panels for GAE630 panels that can be grouped.

All technical information and data contained in these assembly instructions are up to date at the day of printing. We reserve the right for technical changes in course of further development without changing these instructions.

No claims can therefore be raised on the basis of the information and descriptions in these instructions.

We will not assume liability for damage or malfunctions resulting from assembly faults, non-observance of these assembly instructions or unprofessional repairs.

Genuine spare parts from Ormazabal have been specially designed and tested for Ormazabal switchgear.

It is highly recommended to purchase spare parts and accessories only from Ormazabal. We would like to make explicitly clear, that any spare parts and accessories not supplied by us require the approval by Ormazabal.

The assembly and use of other products may have a negative effect on design specific characteristics of the assembly components and thereby impair the safety for man, unit/panel or other property.

For damage resulting from the use of spare parts and accessories not approved by Ormazabal, any liability by Ormazabal is excluded.

Any unauthorized conversions and changes to the assembly components and the related panel types are prohibited for safety reasons and cause the exclusion of any liability by Ormazabal for any damage resulting from this.

## 1.2 Service information

The customer service of Ormazabal Anlagentechnik GmbH is available to provide technical information on Ormazabal products.

## 2 Safety regulations

### 2.1 Explanation of symbols and notes

Observe the following notes and exercise extreme care in such cases. Hand out all notes on health and safety also to all persons who are involved in the panel installation.

Besides the notes in these assembly instructions you must also comply with the generally valid safety and accident prevention instructions (e. g. DIN EN 50110, VDE 0105, BGV A3, TRBS)



#### Symbols on health and safety

In these assembly instructions you will meet these symbols with all notes on health and safety which highlight possible dangers for the health and life of persons



#### Warning against electrical voltage

This special health and safety symbol warns against dangers caused by electrical voltage.

#### Attention!

#### Attention note

This note appears at sections in these assembly instructions, which must be particularly observed in order to comply with guidelines, instructions and the correct work sequence, thereby avoiding damage and destruction of assembly components and unit/panels.

### 2.2 General notes on safety

The assembly components were designed and manufactured according to the latest technical standard and with due consideration of all safety regulations.

However, dangers for persons and property may arise from these assembly components if they are used incorrectly by untrained personnel or for purposes they are not intended for, if they are manipulated or if the safety regulations are disregarded. Each person involved in the assembly of the panel must therefore have read and understood these instructions.

### 2.2.1 Assembly

The assembly must only be performed by authorized persons who have been instructed and trained accordingly.

Before starting assembly work the assembly instructions must be read and strictly observed.

Each person involved in panel installation must be acquainted with these assembly instructions and must have read and understood the chapter "safety regulations" in particular, as well as all further notes on safety.

We recommend that the user/owner demands a written confirmation of this.

Only by knowing these assembly instructions can assembly faults be avoided and trouble free operation assured.

The general safety and accident prevention instruction issued by the legislator and possible regulations of the insurer, which may be different from country to country, must be strictly observed when performing assembly work.

These assembly instructions are part of the assembly components.

When performing assembly work the responsibilities must be clearly specified and complied with, so that no unclear competences regarding safety will arise.

Before taking the switchgear into operation the panel installations must be inspected by qualified personnel concerning their safe condition with respect to accidents and operation.

Before starting operation of a switchgear all persons within the danger zone of this switchgear must be warned and asked to leave this area. No objects must block the access to the control elements.

The user must operate the switch gear only in perfect condition.

Any changes impairing the safety must immediately be reported to the next higher responsible person.

Changes to the assembly components are only permitted in coordination with Ormazabal and under the supervision of expert personnel.

Experts are persons who, due to their professional education and experience, have sufficient knowledge in the field of electro technology and are acquainted with the relevant accident prevention instructions (BGV A3), guidelines and the generally accepted technical rules and regulations (e. g. VDE-regulations, IEC-standards, DIN-standards, TRBS).

### 2.2.2 Safety installations

Safety installations must not be altered, dismantled or made ineffective. Unprotected parts of the system can cause fatal injury.

All safety installations, such as covers, must always be fully functional and correctly in place. Operation of a switchgear with faulty safety installations is not permitted.

### 2.2.3 Auxiliary assembly devices

All auxiliary devices (tools or similar) needed for assembly of the panel must be in a safe condition and should only be used in a safe way.

Any unnecessary and endangering use of auxiliary devices of any kind on the assembly components is not permitted.

### 2.2.4 Statutory accident prevention instructions

Apart from these notes on prevention of accidents and the notes attached to the unit the locally valid accident prevention instructions must also be observed.

### 3 Assembly accessories

#### 3.1 Panel types

Fig. 1 shows the GAE630 panel types and their possible extensibility.

For the assembly kits to be used for the respective panel installation refer to the following chapters and the accessory matrix on the inner cover page at the end of this document.

**Attention!**

If a metering panel (GAE630 1M1-, -1M1, -1M2-, 1M4, 1M5-, -1M5, -1M6-, 1M5Ü) is assembled within the panel combination, proceed as per the assembly instructions for the appropriate metering panel.

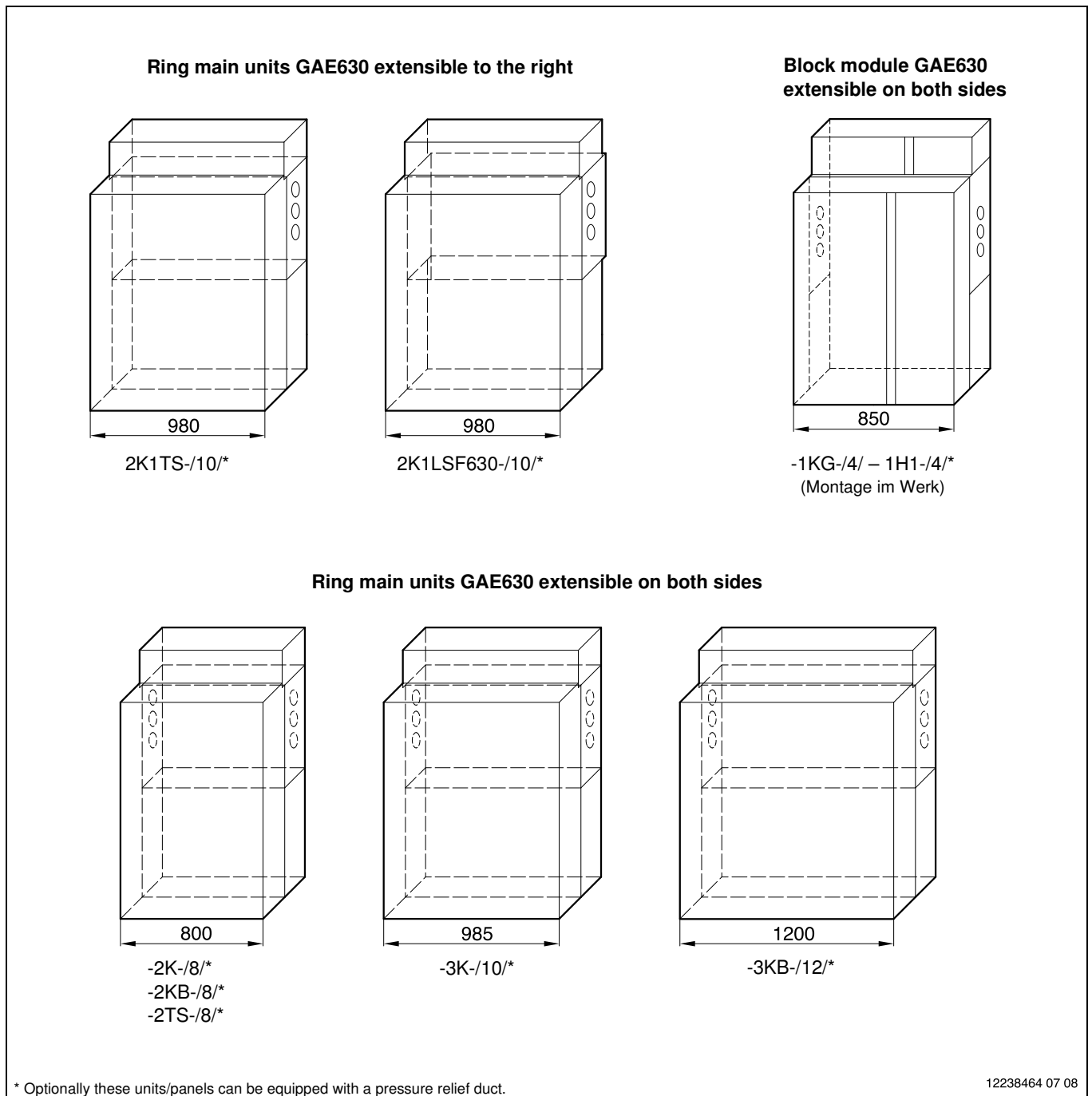

Fig. 1

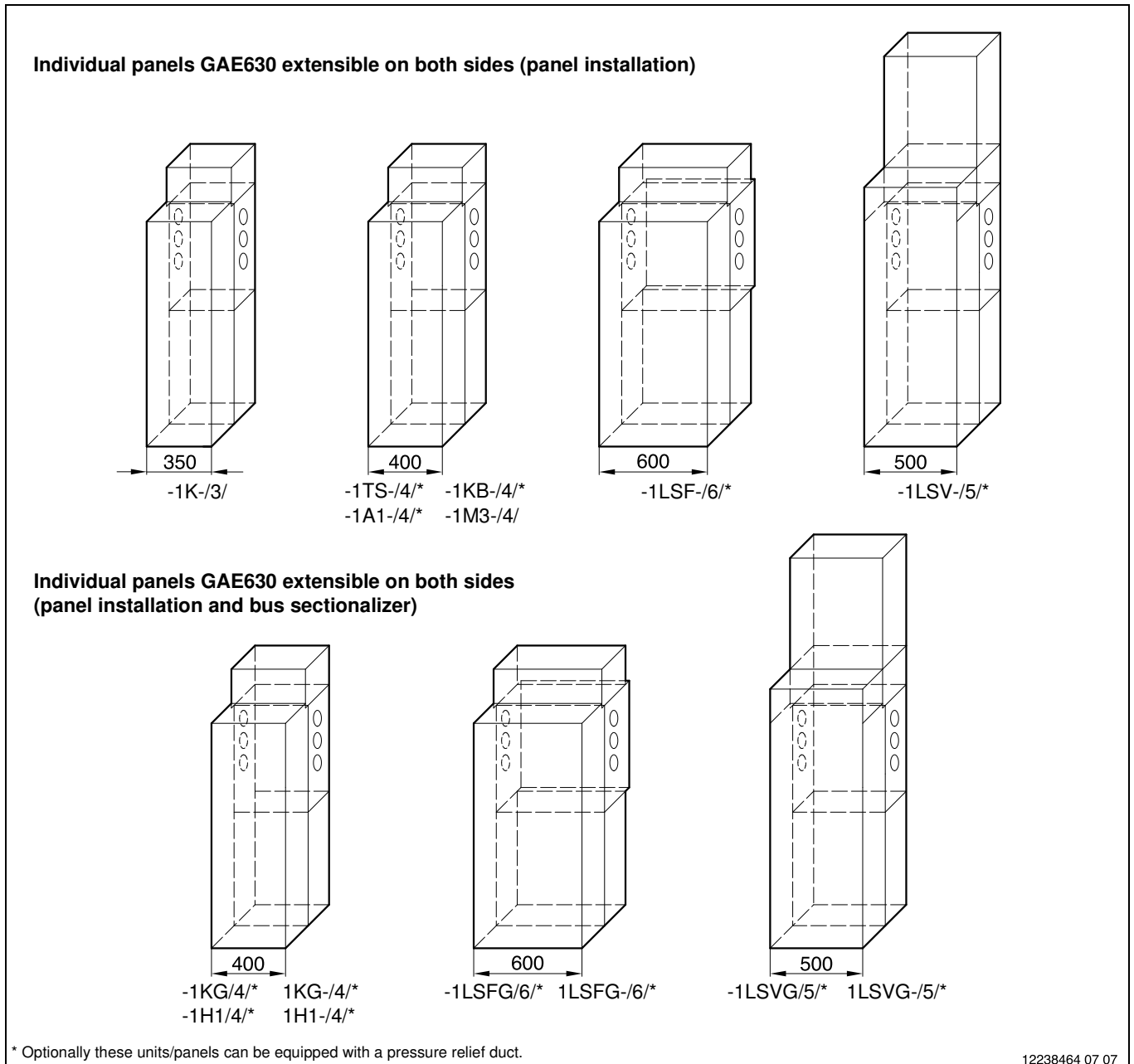

Fig. 2

### 3.2 Assembly components

#### 3.2.1 Standard-accessories kit

Foam rubber brush	1 piece
Disposable gloves	1 pair

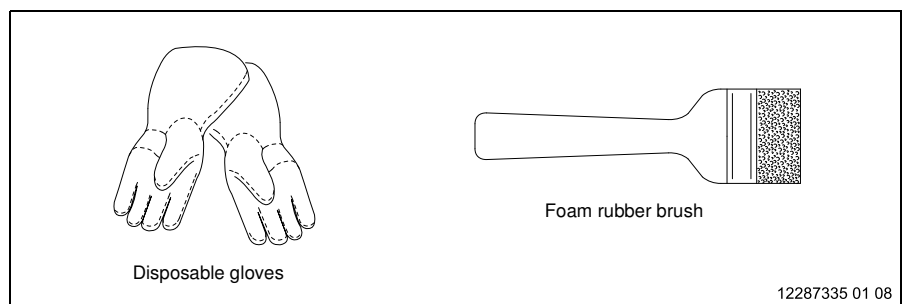

Fig. 3 Standard-accessories kit

### 3.2.2 End panel (Assembly kit 6)

**Attention!**

Before installing the end panel all parts should be checked for transport damage. The individual parts are high quality products and are subjected to stringent quality inspections. Should any damage be detected, contact our customer service department immediately, (see chap. 1.2).

For each end panel the assembly kit consists of the following components (Fig. 4):

Cover	3 pieces
Warning sign (not shown)	3 pieces
Assembly paste	1 piece
Single seal	3 pieces
Nut DIN 986-M5	12 pieces
Washer DIN EN ISO 7093-1-5	12 pieces
Anchoring plate	6 pieces
Cable strap 202x2.5	3 pieces
Plug	1 piece
Clamping nut	1 piece
Cap	1 piece
Flexible plug	3 pieces
Nut DIN 934-M6	3 pieces
Contact washer, serrated M6	6 pieces
Screw DIN 7984-M6x20	3 pieces

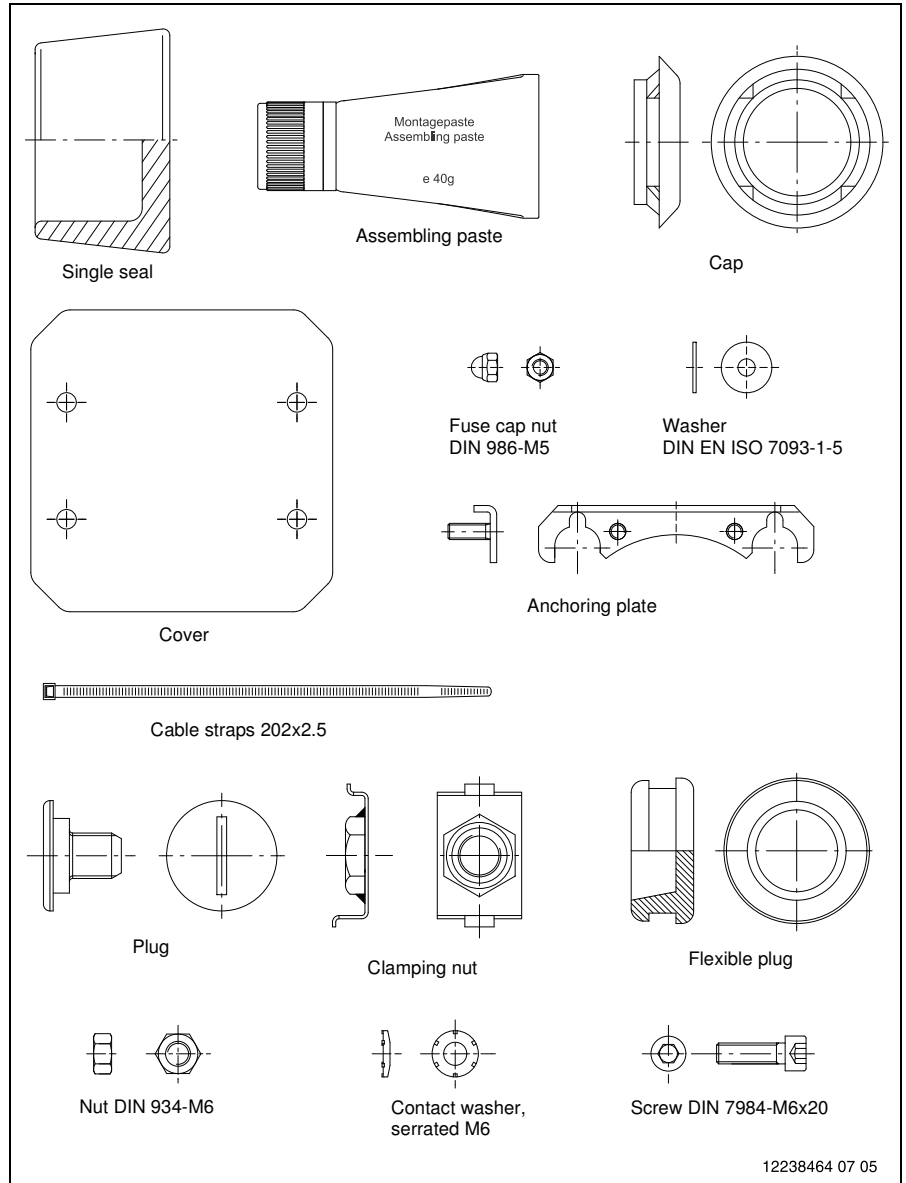

Fig. 4 assembly kit 6

If required a supplementary end panel kit with the following parts is available (Bild 5):

Single seal	3 pieces
Assembly paste	1 piece
Cable strap 202x2.5	3 pieces



Bild 5 supplementary end panel kit

### 3.2.3 Busbar covering sheet for cable connection compartment

#### Attention!

Before installing the busbar covering sheet, all parts should be checked for transport damage. The individual parts are high quality products and are subjected to stringent quality inspections. Should any damage be detected, contact our customer service department immediately (see chap. 1.2).

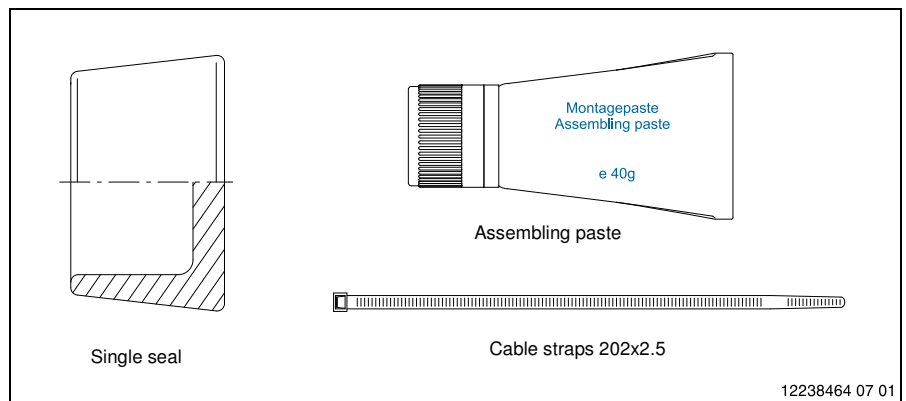
#### Assembly kit busbar covering sheet for GA-/GAE-Standard, left

#### Note!

The assembly kit is only used for panels of type GAE630-1K-/3/, GAE630-1KB-/4/ and GAE630 -1LSF-/6/ (Equipment depth 740 mm).

The assembly kit consists of the following components (Fig. 6):

Busbar covering sheet 365 mm, left	1 piece
non-welding protection sheet 309 mm, left	1 piece
Contact washer, serrated M6	2 pieces
Nut DIN 934-M6	2 pieces

#### Assembly kit busbar covering sheet for GA-/GAE-Standard, right

#### Note!

The assembly kit is only used for panels of type GAE630-1K-/3/, GAE630-1KB-/4/ and GAE630 -1LSF-/6/ (Equipment depth 740 mm).

The assembly kit consists of the following components (Fig. 7):

Busbar covering sheet 365 mm, right	1 piece
non-welding protection sheet 309 mm, left	1 piece
Contact washer, serrated M6	3 pieces
Nut DIN 934-M6	3 pieces

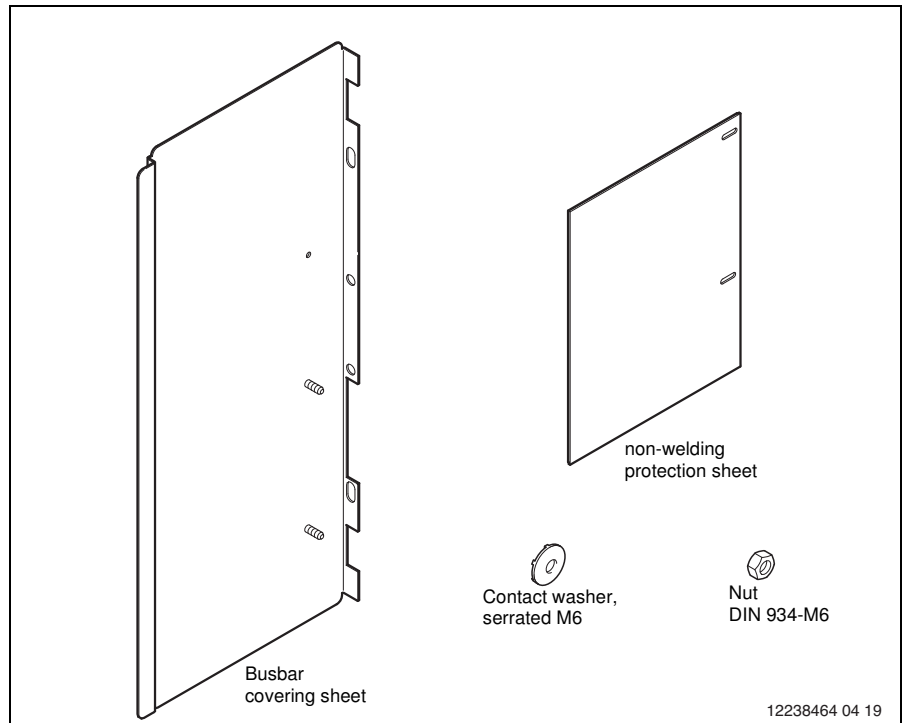

Fig. 6

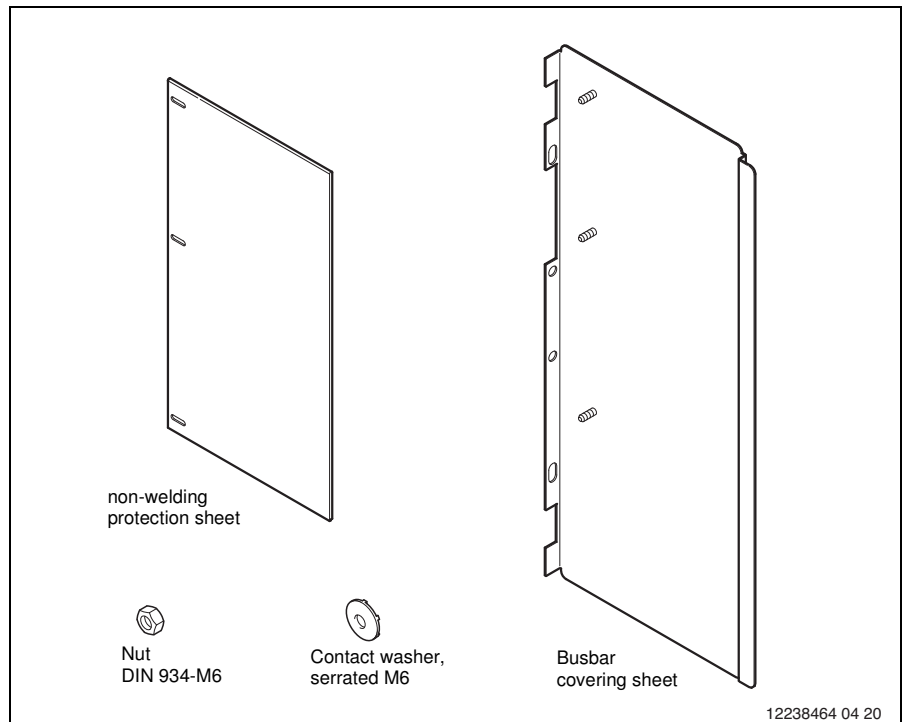

Fig. 7



### 3.2.4 Panel installation

#### Attention!

Before installing the end panel all parts should be checked for transport damage. The individual parts are high quality products and are subjected to stringent quality inspections. Should any damage be detected, contact our customer service department immediately, see chap. 1.2).

#### Assembly kit panel installation GAE630-Standard–GAE630-Standard (Assembly kit 1)

The assembly kit is used to connect GAE630 panel types 2K1LSF630-/10/, 2K1TS-/10/, -2K-/8/, -3K-/10/, -1K-/3/, -1TS-/4/, -1M3-/4/, -1LSV630-/5/, -1LSF-/6/ among each other and consists of the following parts (Fig. 10):

Double seal	3 pieces
Contact pin 630-630	3 pieces

#### Attention!

For the panel combinations GAE630-GAE630 and GAE630-GAE1250 use special assembly kits with contact pins 630-630, or contact pins 630-1250.

Flexible plug	2 pieces
Assembly paste	1 piece
Guide pin	2 pieces
Spacer sleeve	2 pieces
Screw DIN 933 M8x80	2 pieces
Spring washer DIN 6796-8	2 pieces
Washer DIN 9021-A8.4	2 pieces
Screw DIN 7984-M6x20	3 pieces
Contact washer, serrated M6	6 pieces
Nut DIN 934-M6	3 pieces

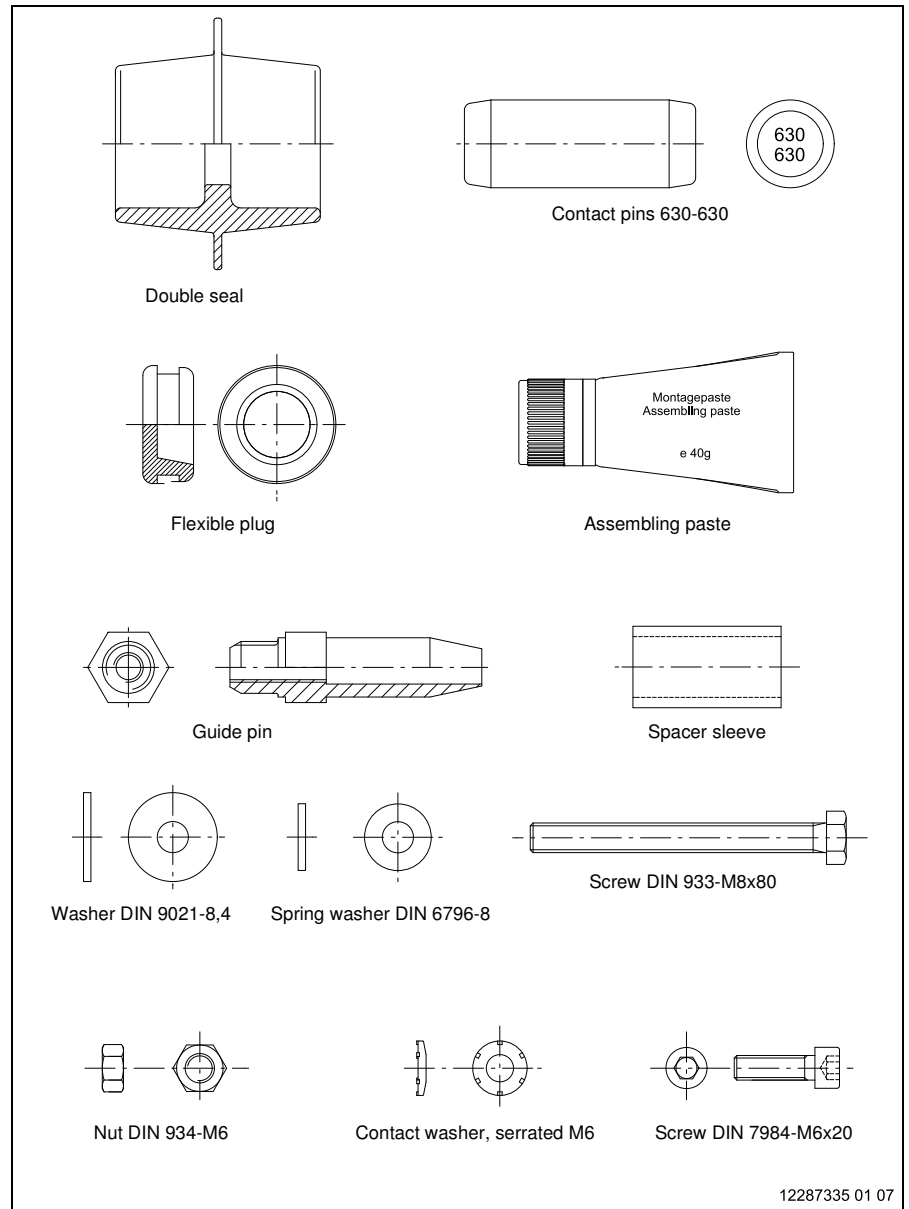

Fig. 10 assembly kit 1

### 3.3 Assembly tools

In addition to the specified assembly components and assembly aids you need the following tools (Fig. 11):

#### Assembly GAE630 end panel

- Flat screw driver size 8
- Combination spanner OW 8

#### Assembly GAE630 panel installation

- Flat screw driver size 8
- 3/8" ratchet
- 3/8" spanner socket OW 13
- 3/8" spanner socket OW 19 (long)
- 1/4" ratchet
- 1/4" spanner socket OW 10
- Combination spanner OW 8
- Combination spanner OW 10
- Open end spanner OW 19
- Open end spanner OW 30
- Torque wrench up to 50 Nm
- Allen key size 4
- Universal pliers

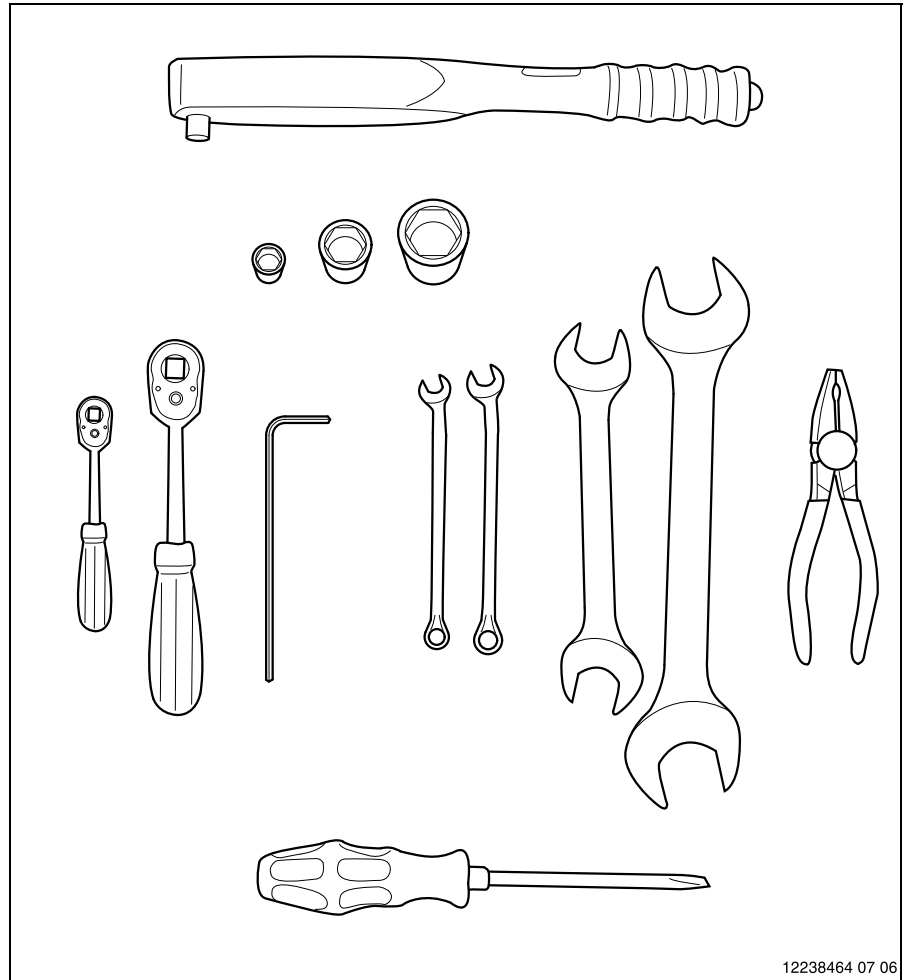

12238464 07 06

Fig. 11

## 4 Assembly sequence

### 4.1 Left-hand end panel

**Note!**

For the extension of an existing line of panels and for ring main units GAE630 2K1TS-/10/, GAE630 2K1LS-/10/ chapter 4.1 is not needed.



**Upon delivery of the GAE-switchgear the lateral bushings are closed with polystyrene caps and the panel installation points with flexible plugs as a protection against dirt.**

**In order to assure the dielectric strength of the switchgear the following assembly steps must be performed**

- 1.** Remove the front cover.  
For a description of the procedure please refer to the section "Operation" in the operating instructions for the corresponding GAE panel.

**Note!**

Perform assembly step 2 only for accidental arc resistant panels.

- 2.** Remove the bus bar covering sheet from the top part of the cable connection housing (Fig. 12). For this purpose unscrew both fastening screws and pull the sheet out of the clip-on clamps.

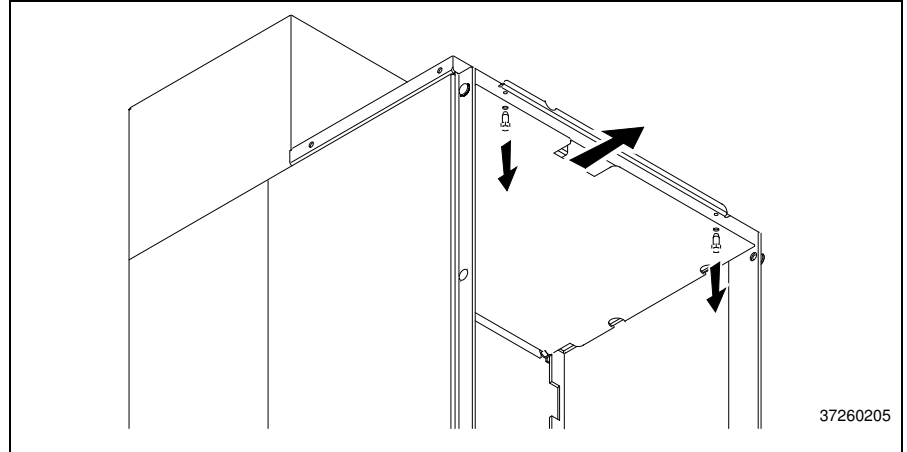

Fig. 12

**3.** Secure the bottom panel installation point.

- Remove the adhesive foil from the bottom panel installation point (Fig. 13).
- In the cable connection compartment insert the clamping nut (Fig. 13) into the fastening angle.  
To do so insert the clamping nut with the short side into the small opening of the fastening angle and then press the long side into the large opening of the fastening angle.
- Turn the plug (Fig. 13) with a screwdriver from outside into the bottom panel installation point (tightening torque: 10 Nm).

**4.** Screw connections of the cable connection compartment

Close the lateral bores in the cable connection compartment as shown in Fig. 13.

- 5.** Remove the adhesive foil from the top panel installation point and the openings for the cable gland. Close all openings with a cap (panel installation point) and two flexible plugs (cable gland points) as shown in Fig. 13.

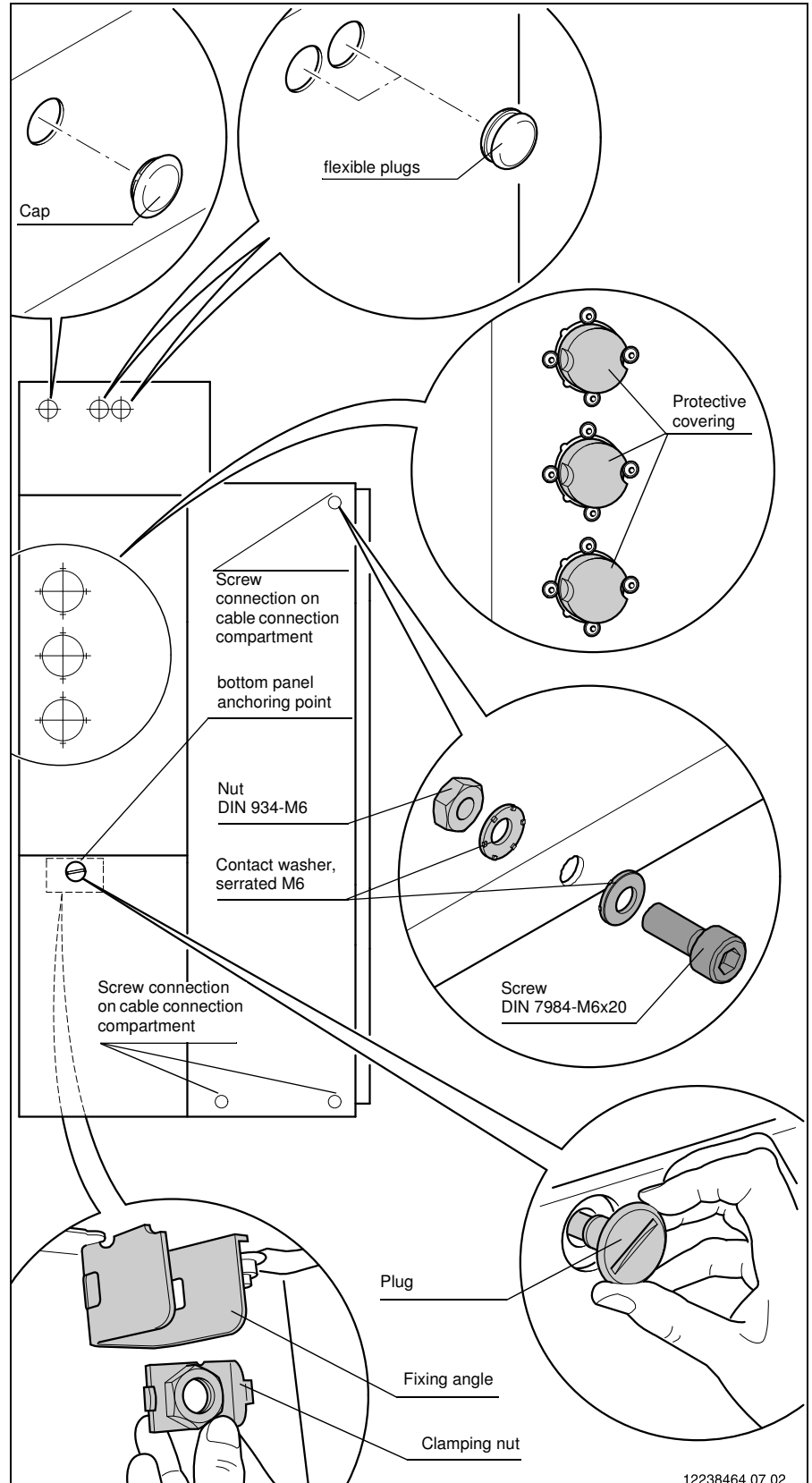

Fig. 13

12238464 07 02

**Note!**

Perform assembly step 6 only for accidental arc resistant panels.

**6.** Assembly of the busbar covering sheet in the upper part of the cable connection compartment takes place in reverse order to assembly step 2.

**Attention!**

The busbar covering sheet must be correctly positioned (Fig. 14) and click into both clip-on clamps in the rear section of the cable connection compartment.

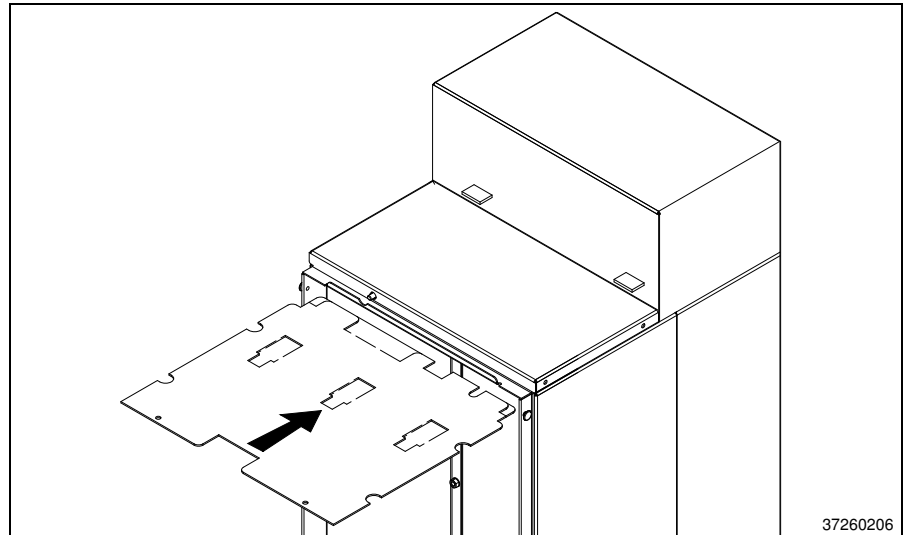

Fig. 14

**Note!**

Assembly steps 7 and 8 do not apply to panels of type GAE630 -1TS-/4/ and GAE630 -1LSV-/5/.

**7** Assembly of the lateral busbar covering sheet

- Loosen the screws in the left side wall of the cable connection compartment (Fig. 15).

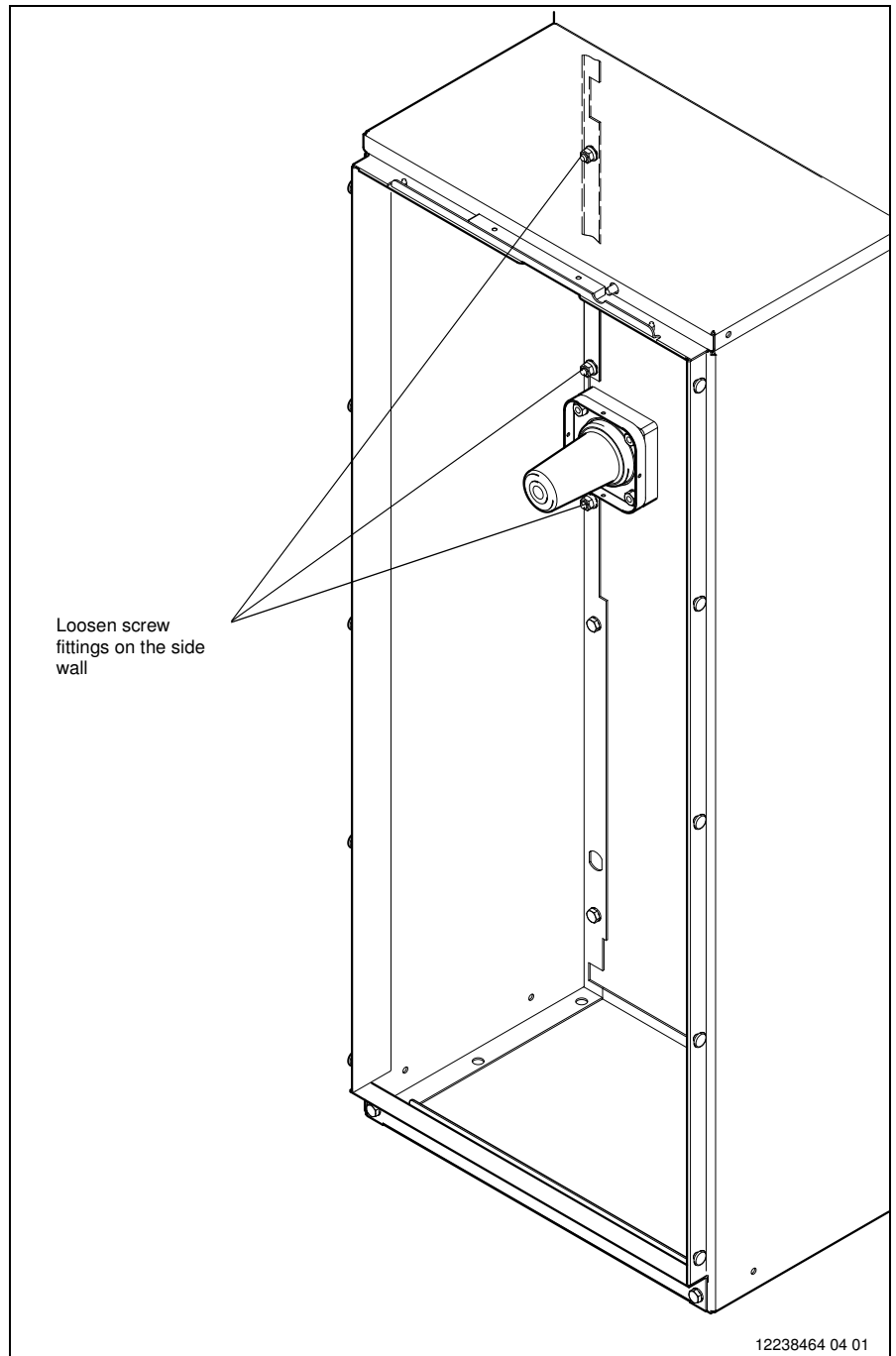

Fig. 15

- Attach the busbar covering sheet on the previously loosened screws according to Fig. 16. Use the provided spring washers DIN 6796-8 instead of the contact washers.

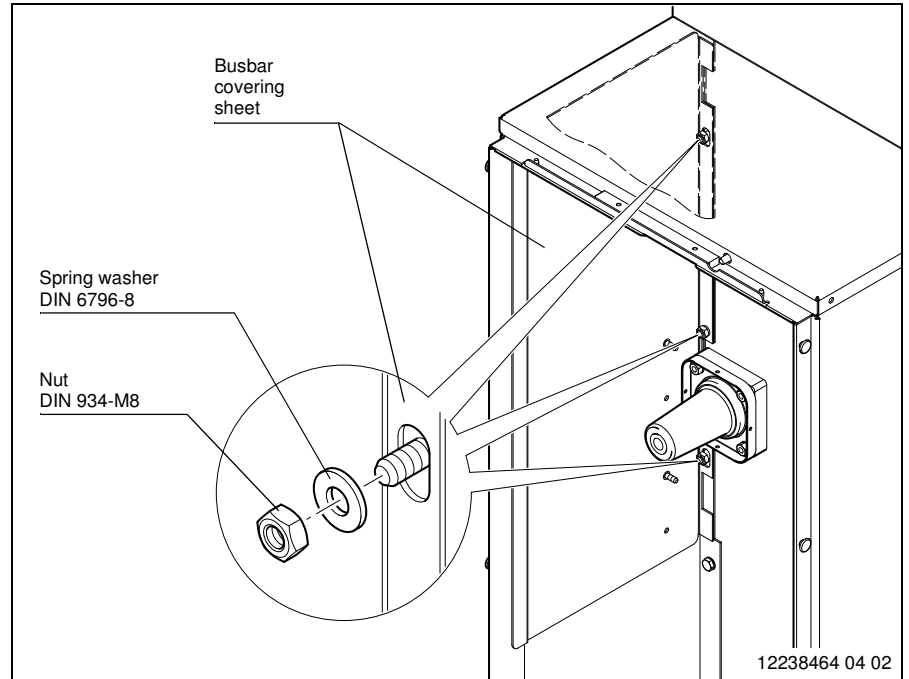

Fig. 16

## 8. Assembly of the lateral non-welding protection sheet

Use the non-welding protection sheet according to Fig. 17 and fasten to the busbar covering sheet.

## 9. Installation of the front cover

Installation of the front cover is performed in reverse order to assembly step 1.

### Note!

Assembly steps 10 to 13 must be performed on the bushings L1 to L3 on the left hand side of the end panel.

10. Pull the polystyrene caps (Fig. 13) out of the lateral bushings L1 to L3.

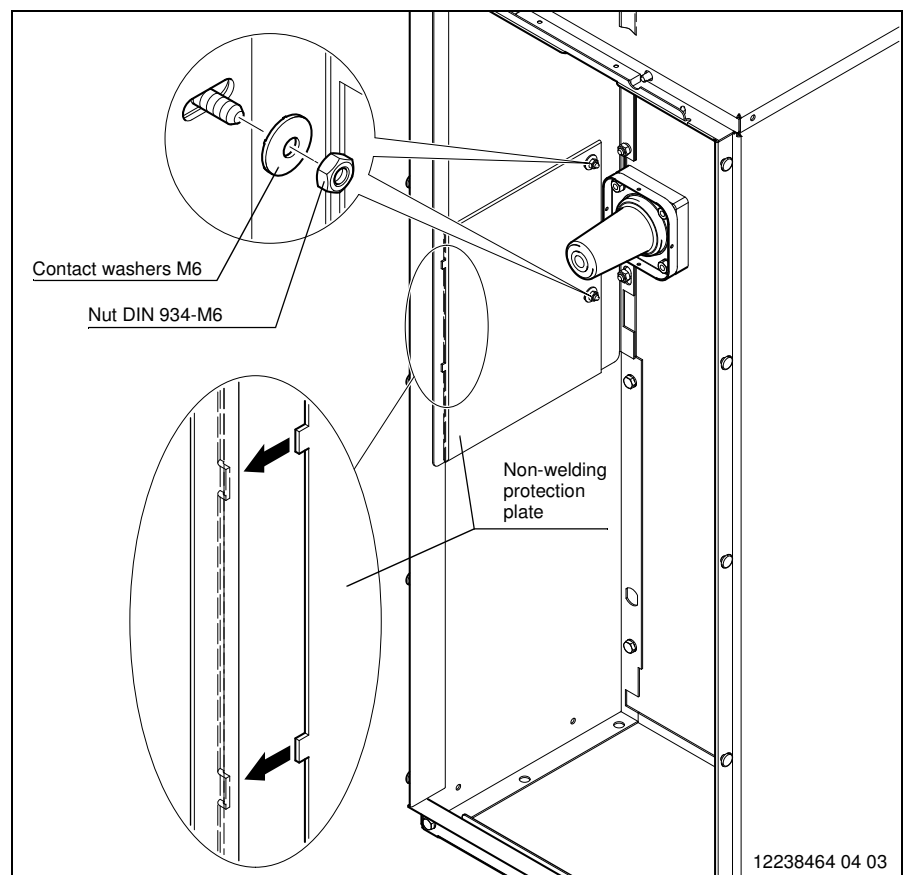

Fig. 17

**11.** Cover the following surfaces completely with a thin and even film of the assembling paste (order-no. 12201700):

- Push-on surfaces of the bushings,
- Push-on surfaces of single seals.

**⚠ Wear safety gloves (disposable gloves)**

**Attention!**

- The single seals must be free of damage, clean and free of dust.
- Dirt can be removed with a lint-free cloth soaked in commercial household detergent. Then wipe off with clear water and allow to dry.
- Damaged single seals must be disposed off and should not be used. Single seals can be ordered in a supplementary kit (order no. 12238779) from Ormazabal (see chapter ).
- No other than the specified assembling paste may be used!
- Use only the supplied foam rubber brush to apply grease.
- The covered surfaces must be free of foreign particles.
- Clean the silicon components with a lint-free cloth.
- Do not use any aggressive solvents.

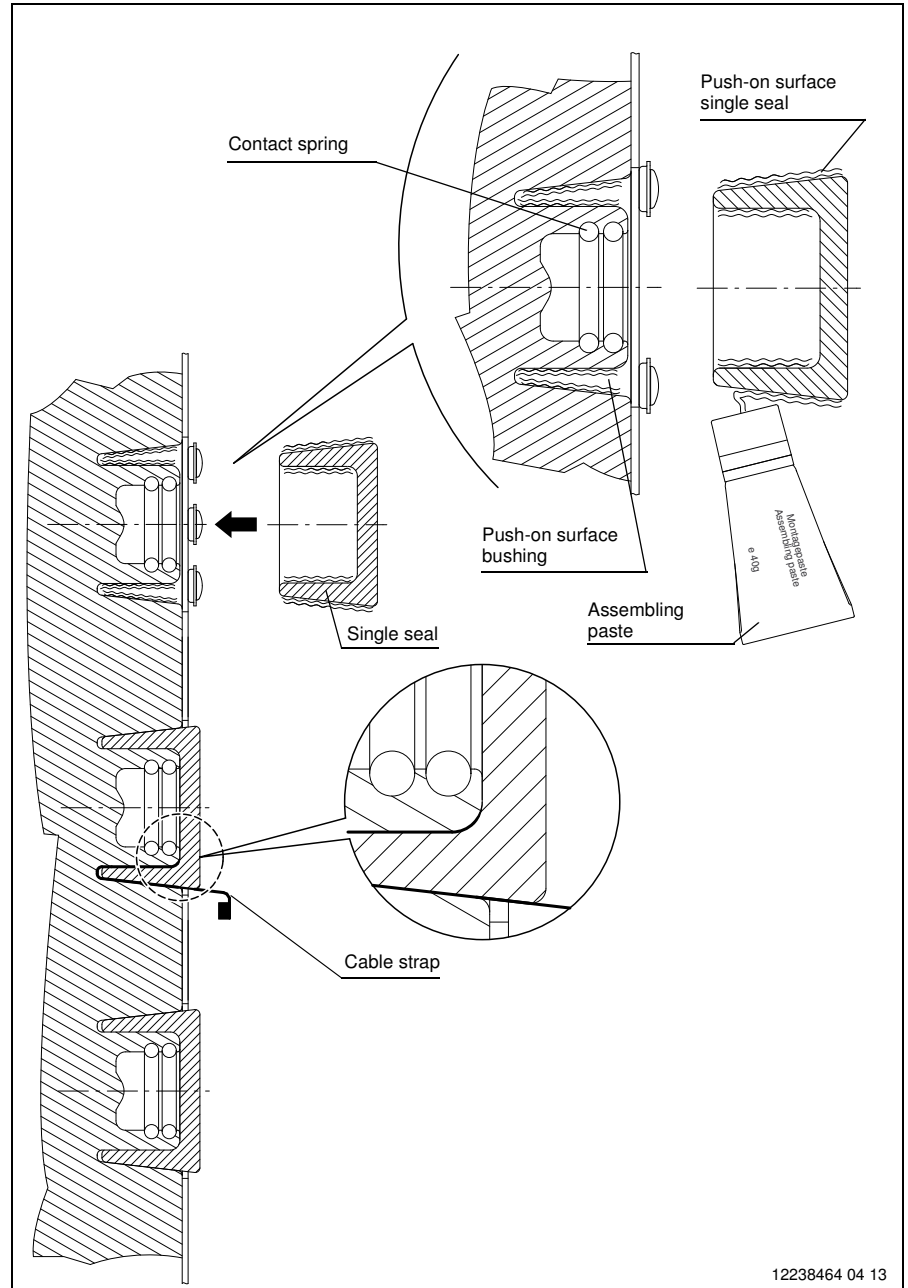

Fig. 18

**12.** Inserting the single seal.

Press the single seal together with the supplied cable strap by hand into the bushing. Make sure the tothing of the cable strap does not rest on the surface of the single seal. Ensure that the cable strap reaches right into the bushing.

Press the middle of the seal with your thumb and pull the cable strap carefully out. Turn the single seal so far, that the dislodged grease layer is evenly distributed again.

**Attention!**

Do not forget the cable strap. When inserting the single seal the cable strap makes sure that the overpressure can be relieved through the bushing. If this is not observed there is a risk that the seal does not properly insulate the bushing.

### 13. Assemble the sealing ends (Fig. 19).

- Slide the fastening angle laterally under the cup discs.

 The fastenings of the cup discs must **not** be loosened, as otherwise the water tightness of the lateral bushings can no longer be assured.

- Press the fastening angles by hand until they click into place, if necessary give it a blow with the palm of your hand and a blunt object (e. hammer shaft) so that it clicks into place.
- Attach the cover and fasten with washers DIN EN ISO 7093-1-5 and nuts DIN 986-M5 (tightening torque: 6 Nm).

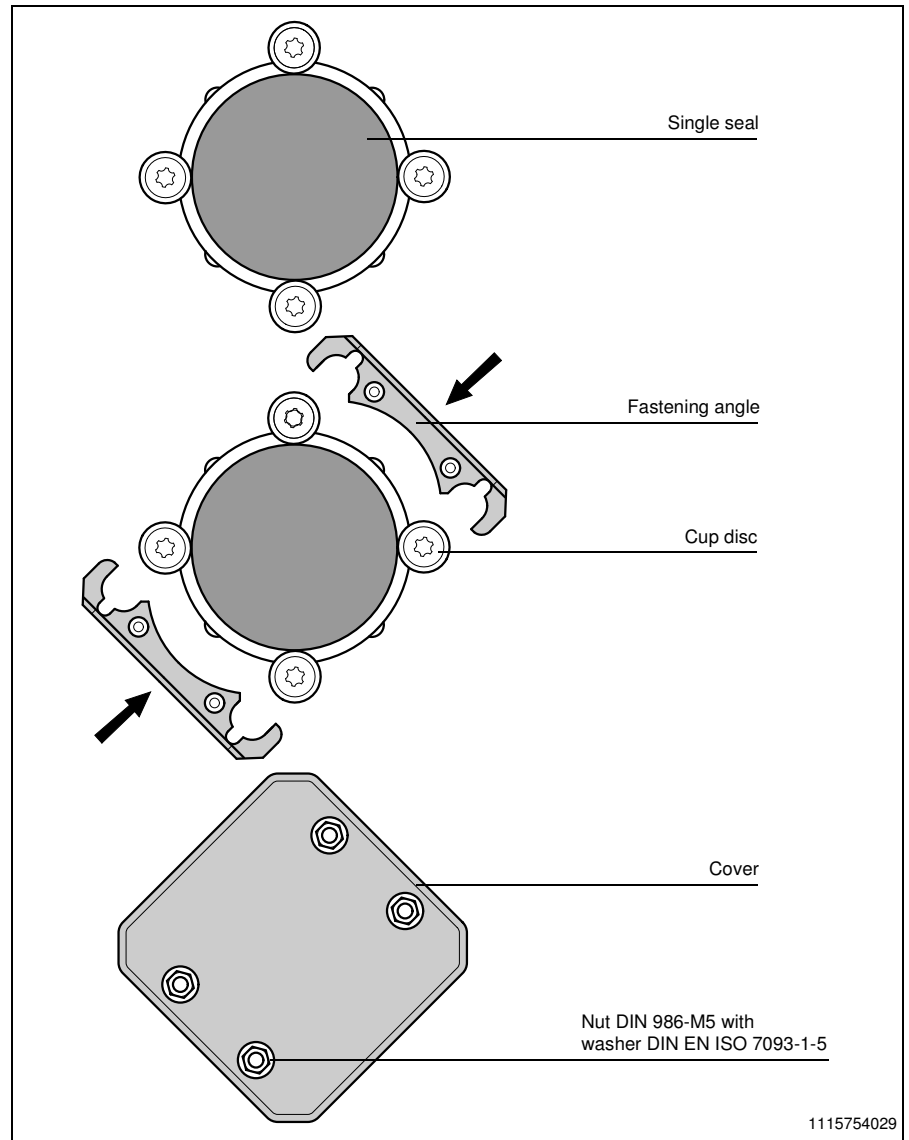

Fig. 19

#### 4.2 Panel installation GAE630-Standard with GAE630-Standard

The following assembly sequence describes the connection of GAE630 panels/-blocks of types 2K1LSF-/10/, 2K1TS-/10/, -3K-/10/, -1E-/3/, -1K-/3/, -1TS-/4/, -1M3-/4/, -1LSV-/5/, -1LSF-/6/ with one another.



When extending an existing line of GAE630 panels, the busbar line of the switchgear must be de-energized and the associated safety measures (BGV A3, VDE 0105 Part 100, DIN EN 50110) must be applied.

**Note!**

Joining of GAE630 panels is in most cases performed to the right. For simplicity, in the following the left-hand panel is referred to as panel 1 and the right-hand panel as panel 2 (Fig. 20).

**1.** When assembling a line of GAE630 panels, first position and fasten panel 1 above the floor opening. The dimensions for the floor opening and the installation points as well as the assembly sequence can be found in the operating instructions for the respective GAE panel.

**2.** Place panel 2 at a distance of approx. 0.3 m to the right of panel 1 (Fig. 20). During assembly observe the notes in the chapter “transport and assembly” in the operating instructions for the respective GAE panel.

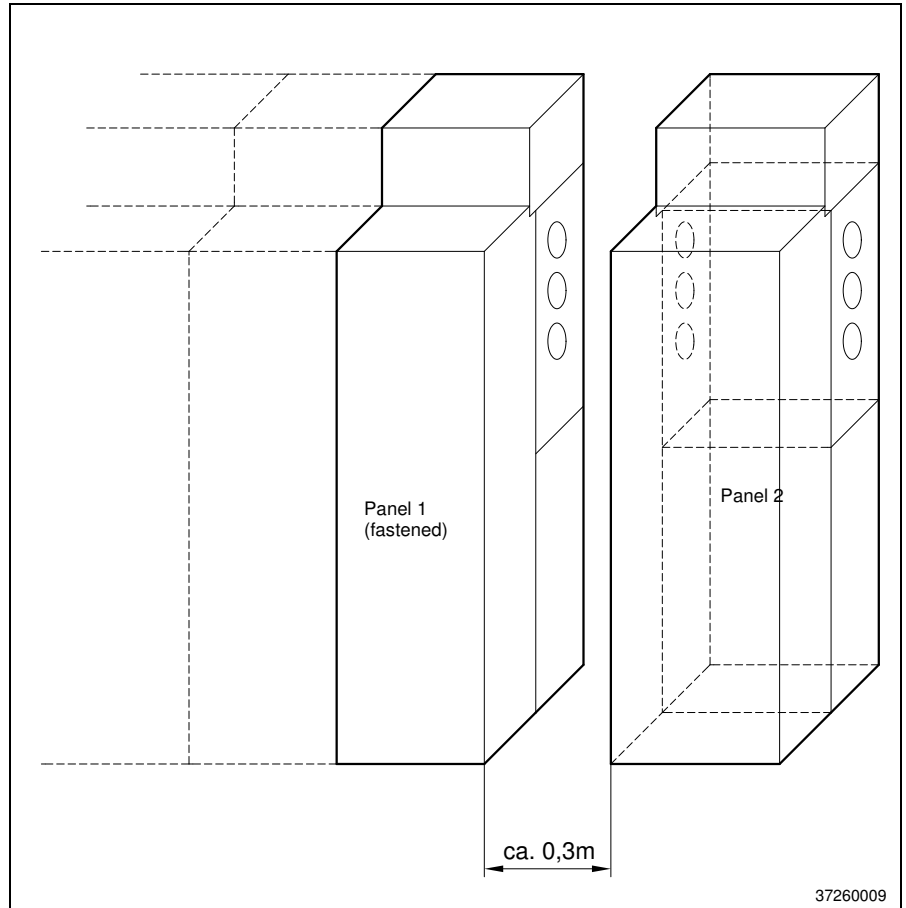

Fig. 20

**Note!**

Perform the following assembly steps 3 and 4 only on panel 2.

**3.** Disassemble the transport angles (Fig. 21). Slacken the screws (OW 13) on the transport angles and take them off together with the transport angles.

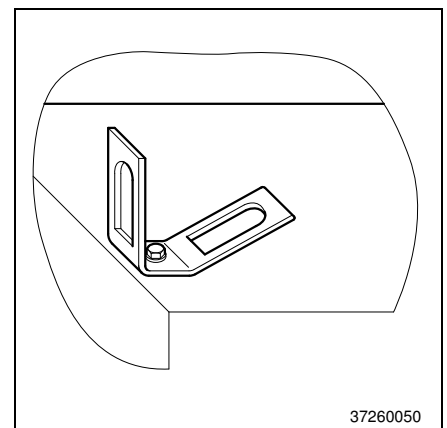

Fig. 21

**4.** Remove the cover plate to gain access to the top panel installation point.



When working on an open drive it must be in relieved and switched off condition. Accidental triggering of the drive can cause severe injury!

- Unscrew the hexagon screws (2x) from the covering sheet.
- Unscrew all self-tapping screws (Fig. 22) from the upper section of the front panel. Depending on the GAE630 panel type, the number of screws may be different.
- Pull the front panel a few millimetres forward (Fig. 22/A).
- Lift the cover plate up from behind the front panel (Fig. 22/B).
- Pull the cover plate out of the openings of the frame (Fig. 22/C).

Optionally a relay box may be installed instead of the cover plate. In this case please proceed as follows:

- Turn the fastener for the front panel of the relay box with a square socket key to the left (with left hand door stop) or the right (if right hand door stop).
- Open the front panel.
- Loosen both fastenings of the floorcovering sheet (on GAE630 blocks, GAE630 2K1TS-/10/, GAE630 2K1LSF-/10/, GAE630 -3K-/10/ only the right floor sheet).
- Pull the covering plate out.

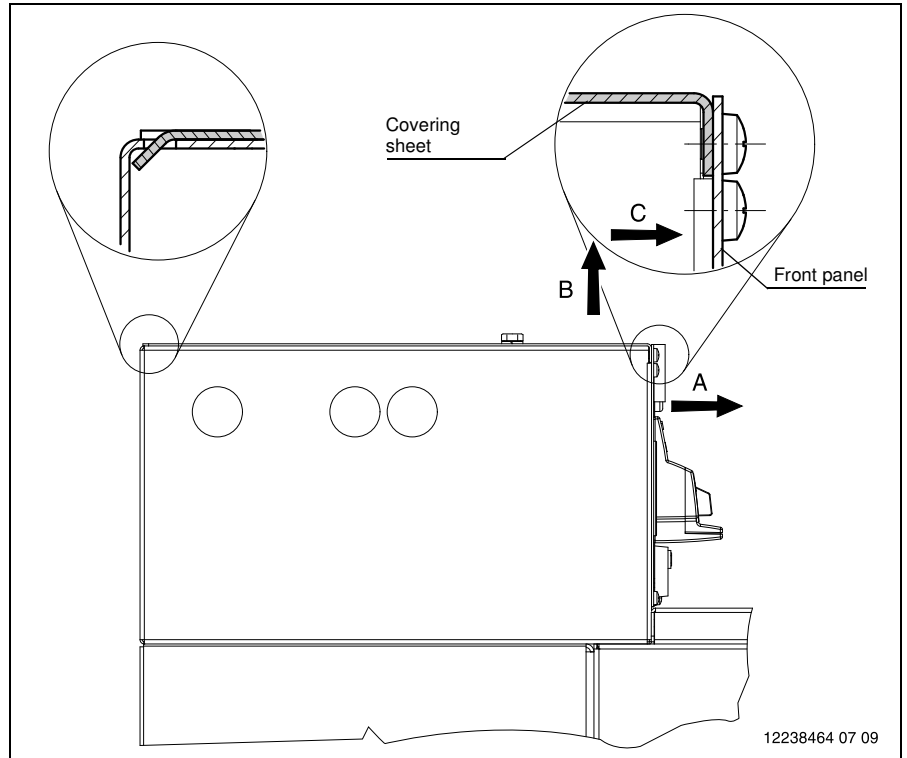

Fig. 22

**5.** Remove the front covers from panels 1 and 2 (Fig. 23) in order to gain access to the bottom panel installation point and to the fittings of the cable connection compartment.

For a description of the procedure please refer to the chapter "Operation" in the operating instructions for the corresponding GAE panel.

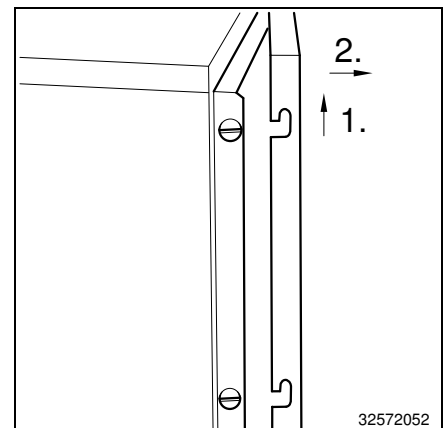

Fig. 23

**Note!**

Perform assembly step 6 only for accidental arc resistant panels.

6. Remove the bus bar covering sheet from the top part of the cable connection housing (Fig. 24). For this purpose unscrew both fastening screws and pull the sheet out of the clip-on clamps.

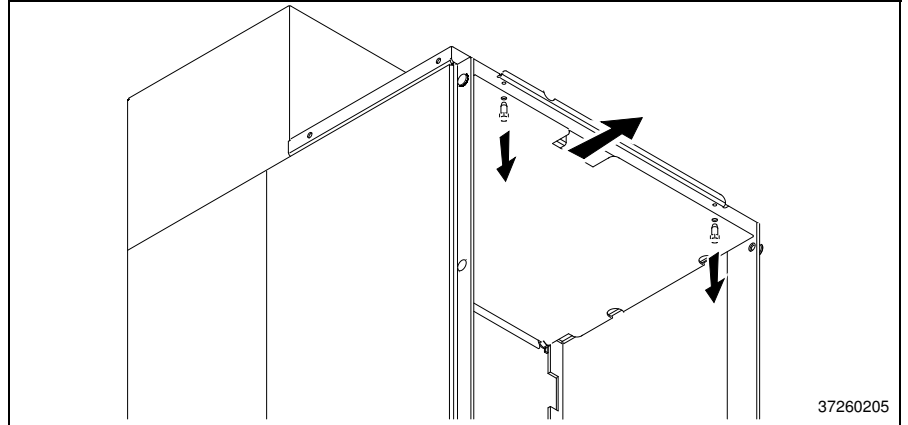

Fig. 24

**Note!**

Perform the assembly steps 7 to 9 on the right hand side of panel 1 and on the left hand side of panel 2.

7. Remove all adhesive foils from the openings of the cable bushings (Fig. 25).

8. Open panel installation points.

- Remove the adhesive foils from the top and bottom panel installation points (Fig. 25).
- With assembled end panels remove the plug (Fig. 26) from the bottom panel installation point using a screw driver.
- On a left hand end panel you must also remove the clamping nut. To do so insert a flat object (e. g. flat screw driver) behind the longer side of the clamping nut and press it out (Fig. 27).

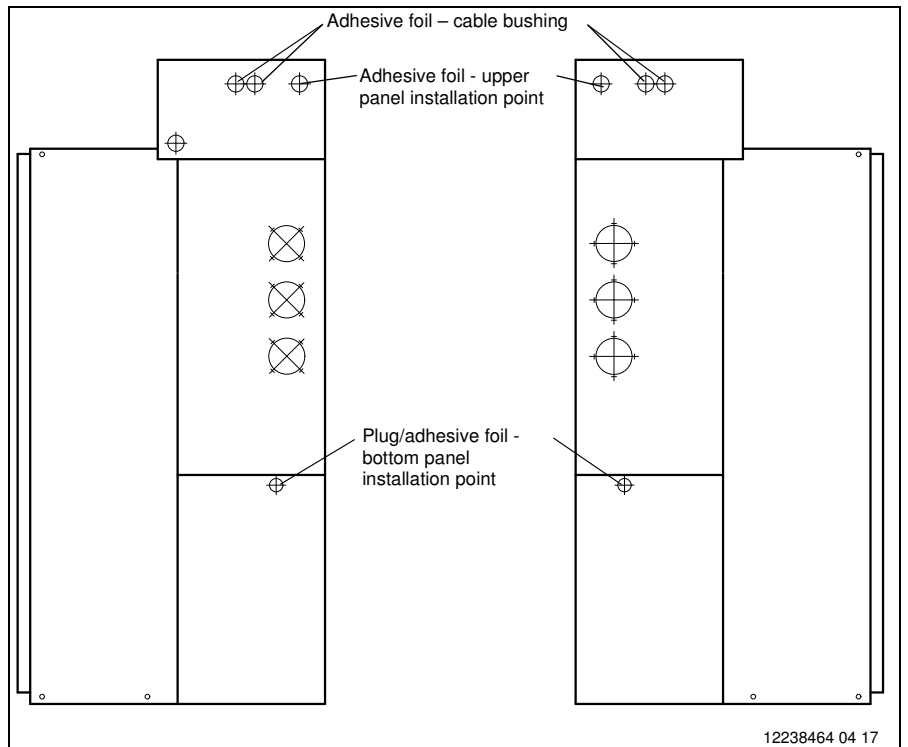

Fig. 25

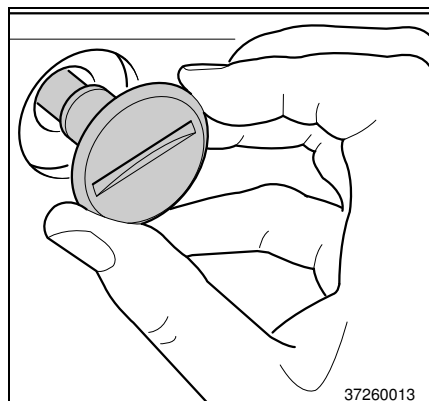

Fig. 26

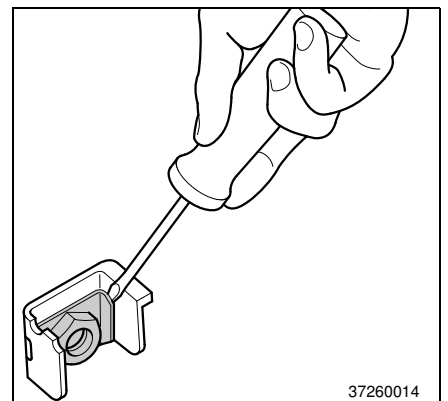



Fig. 27

## 9. Remove the covers from the lateral bushings.

- Remove the transport protection caps from all bushings on the panel sides to be joined.
- With assembled end panels remove the sealing ends from the lateral bushings L1 to L3:
  - Loosen nuts and washers (OW 8) and remove the cover (Fig. 28).
  - Pull both fastening angles laterally out from under the cup discs (Fig. 28).

 The fastenings of the cup discs must **not** be loosened, as otherwise the water tightness of the lateral bushings can no longer be assured.

- Cut the single seal with a sharp knife across the free surface (ventilation) (Fig. 28).
- Grip with your fingers into the cut and pull the single seal out (Fig. 28).

 The cut single seals must be disposed of and should not be reused. Clean the bushings with a lint-free cloth from all contaminated rests of grease.

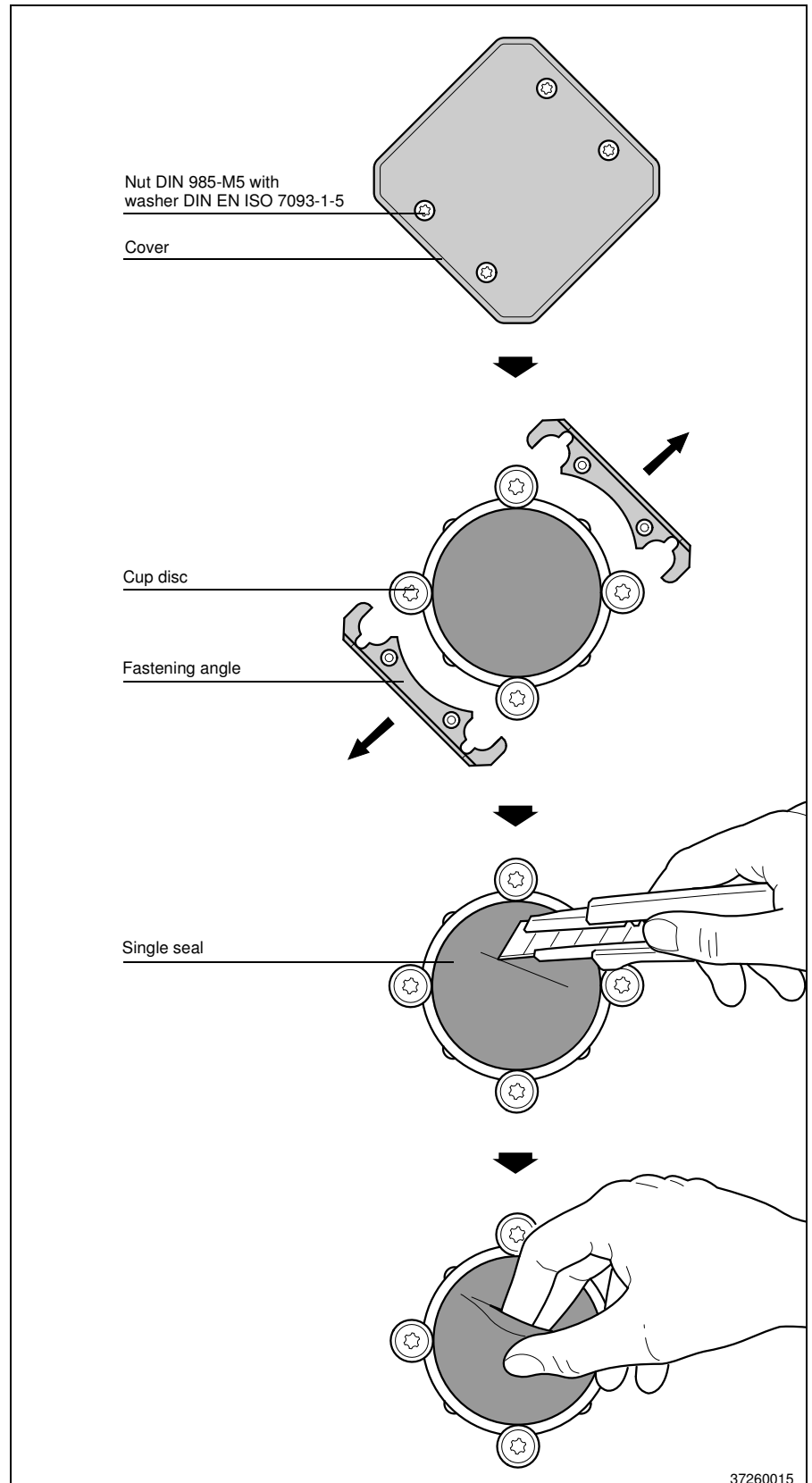

Fig. 28

## 10. Assembly of the guide pins (Fig. 29)

**Note!**

This assembly step must only be performed on the right hand side of panel 1.

Screw a guide pin (OW 19) into the top and bottom panel installation point (tightening torque: 50 Nm).

**Attention!**

During assembly the guide pin and the clamping nut have to be centered lest they tilt.

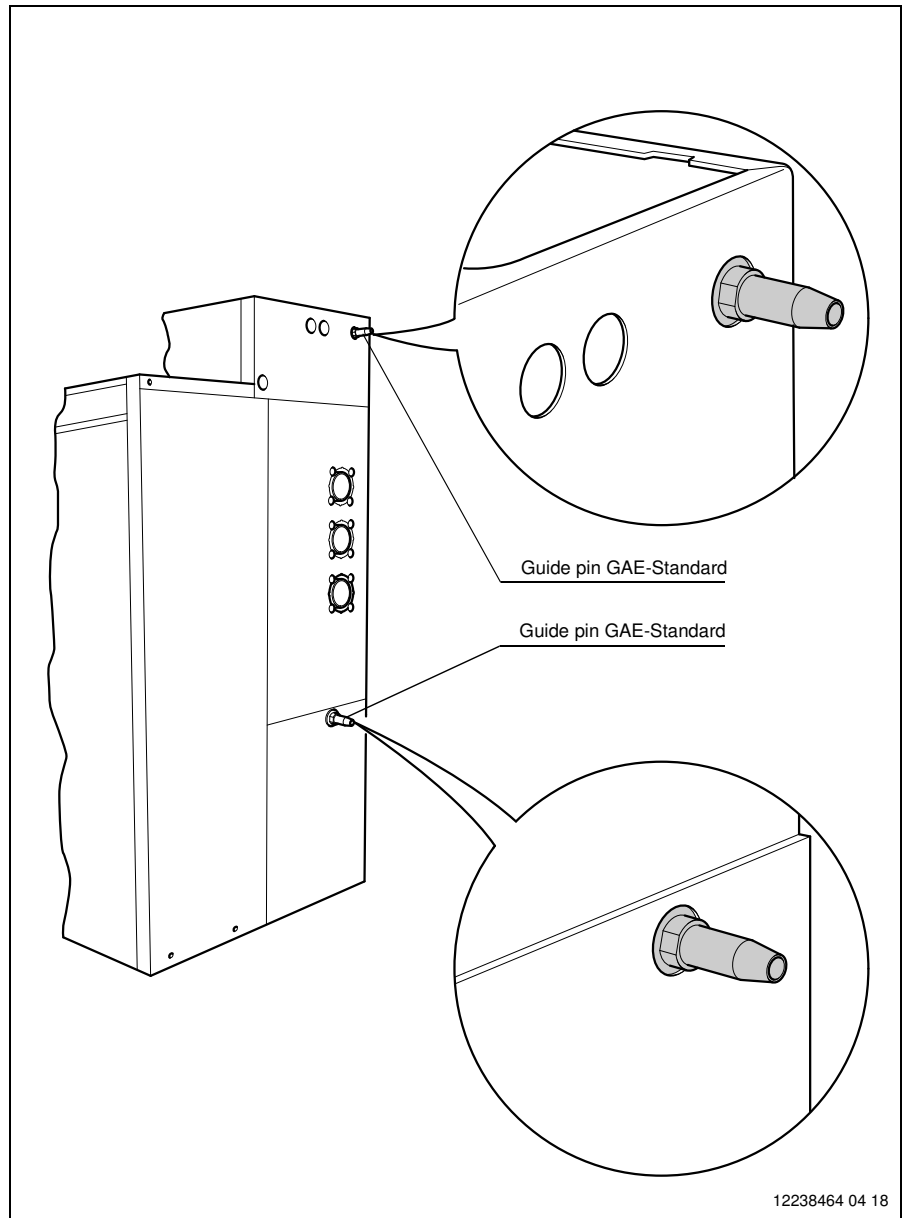

Fig. 29

**11.** Grease the following surfaces completely with a thin film of the assembling paste (order-no. 12201700):

- Push-on surfaces for bushings
- Contact pins,
- Push-on surfaces of double seals

**⚠ Wear safety gloves (disposable gloves)!**

**Attention!**

- The seals must be free of damage, clean and free of dust.
- Clean off strongly adhesive, e. g. greasy dirt with a lint-free cloth soaked in a commercial detergent. Then wipe off with clear water and allow to dry.
- No other than the specified assembling paste may be used!
- Use only the supplied foam rubber brush to apply grease.
- The covered surfaces must be free of foreign particles.
- Clean the silicon components with a lint-free cloth.
- Do not use any aggressive solvents.

**12.** Inserting the assembly components

**Attention!**

Before inserting the assembly components make sure that the already inserted contact springs are not damaged and do not show any signs of corrosion. The springs must **not** be taken out for this purpose.

In case of additional panel installation of GAE-panels which were already in operation the contact springs have to be changed generally.

Therefore please contact the customer service of Ormazabal Anlagentechnik GmbH stating the type of panel.

Do not use any striking tools to insert the assembly components. The application of force may destroy the bushings.

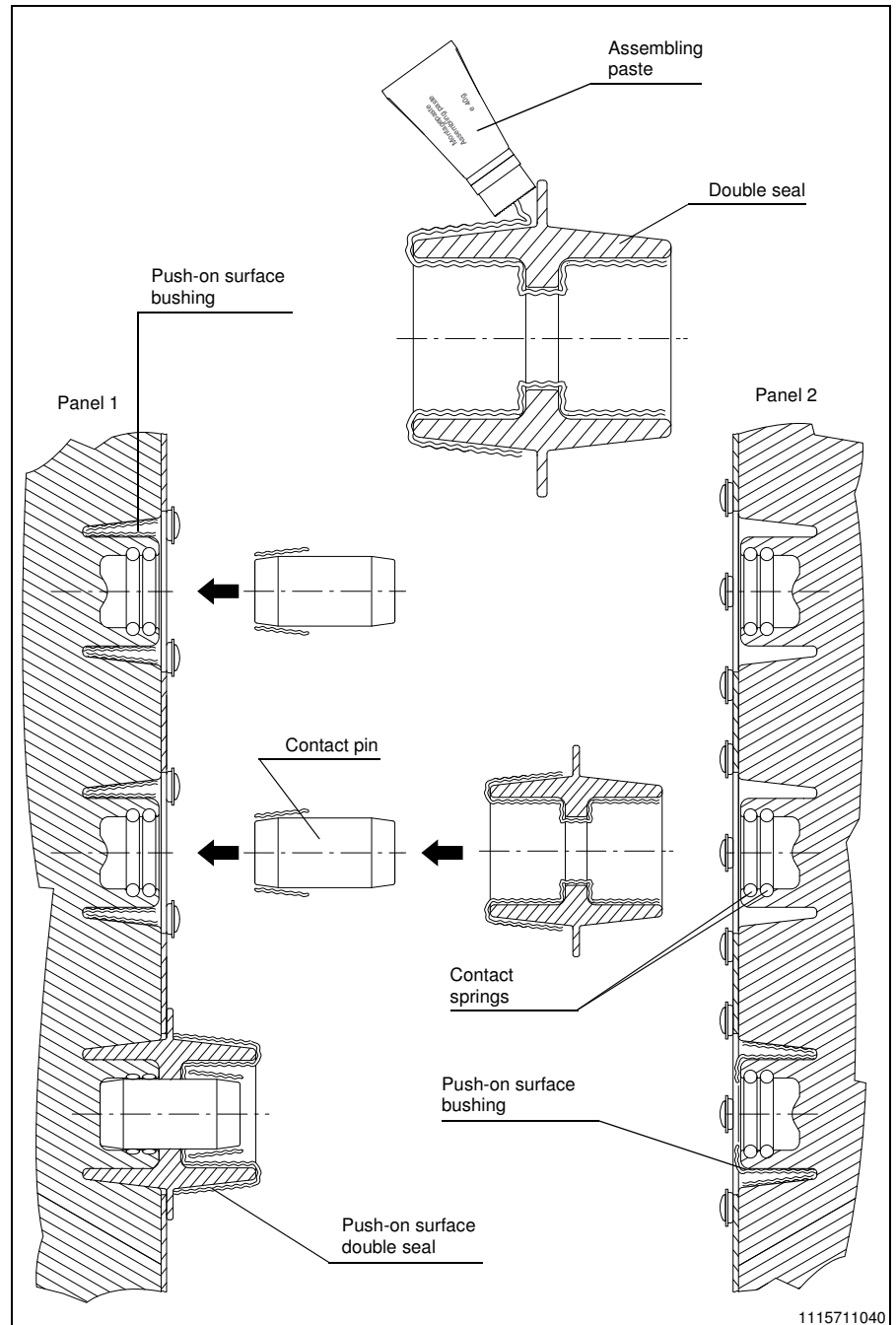

Fig. 30

**Note!**

This assembly step must only be performed on the right hand side of panel 1.

Press one contact pin each by hand straight into bushings L1 to L3 without wedging. Then insert the double seals (Fig. 30).

**13.** Grease all assembled double seals at the push-on surface of the opposite bushing by applying a thin and even coat of assembling paste. Observe the attention notes in assembly step 11!

## 14. Joining the panels (Fig. 31)

Push panel 2 in one go so close to panel 1 that the guide pins enter into the opposite bores in the fastening brackets and the double seals are pressed into the opposite bushings. In case of extreme flatness faults of the floor it may be necessary to loosen panel 1 in order to equalize the flatness fault by furring. The distance between the panels is now approx. 30 mm.

**Attention!**

Panel 2 must be aligned to panel 1 so that the side walls are parallel to each other. Jamming of the panels can cause damage to bushings and inserted assembly components.

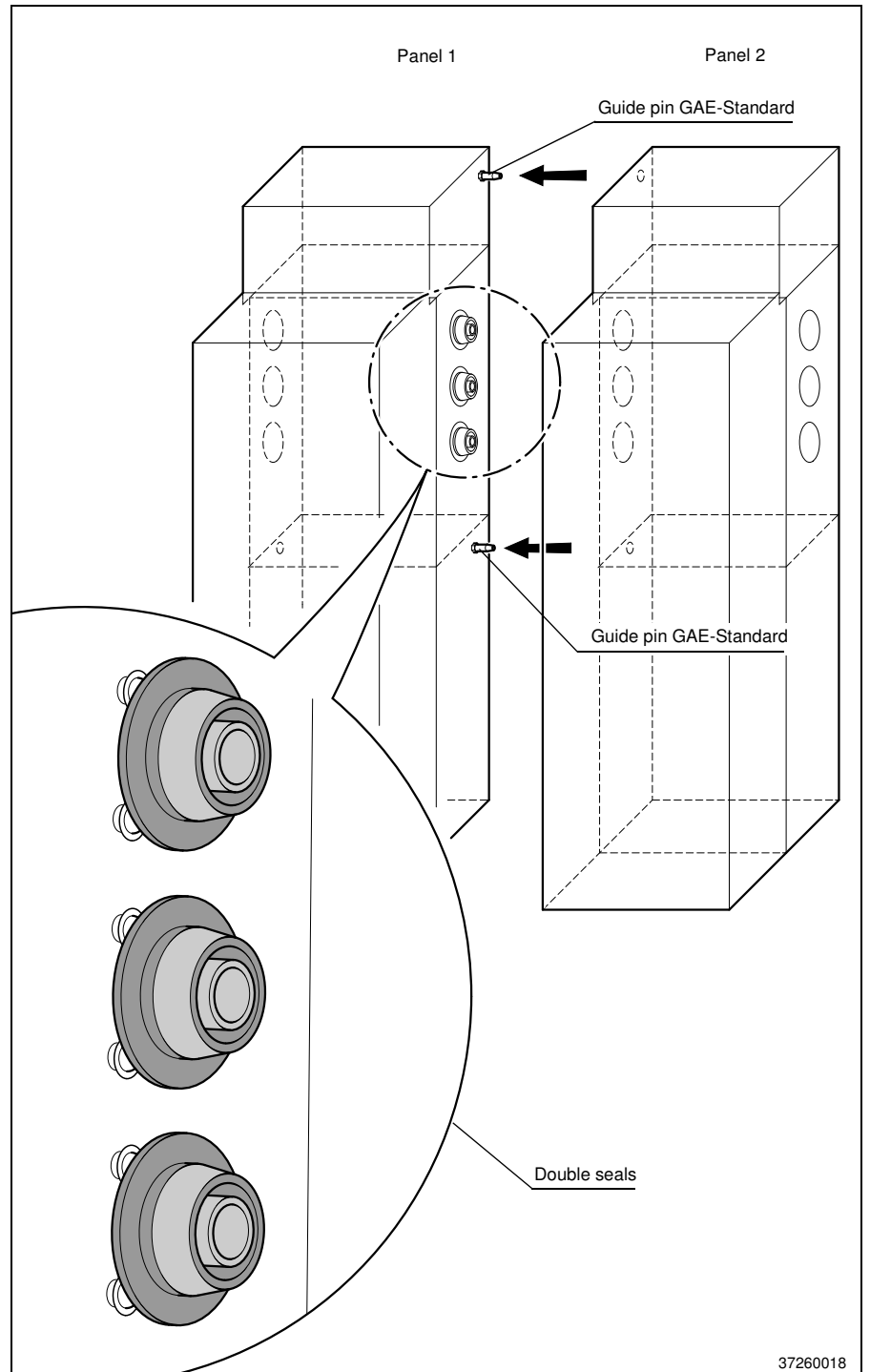

Fig. 31

## 15. Fastening the panels (Fig. 32)

In the top and bottom fastening brackets on the left hand side of panel insert a spacer sleeve, washer DIN 9021-A8.4, spring washer DIN 6796-8 and screw DIN 933-M8x80 and screw into the guide pins of panel 1.

If the screws do not engage in the thread of the guide pins the distance of the panels must be adapted accordingly.

Tighten the top and bottom screws alternately. Panel 2 is thereby pulled tightly against panel 1 until it bottoms. Tighten the screws with a tightening torque of 25 Nm.

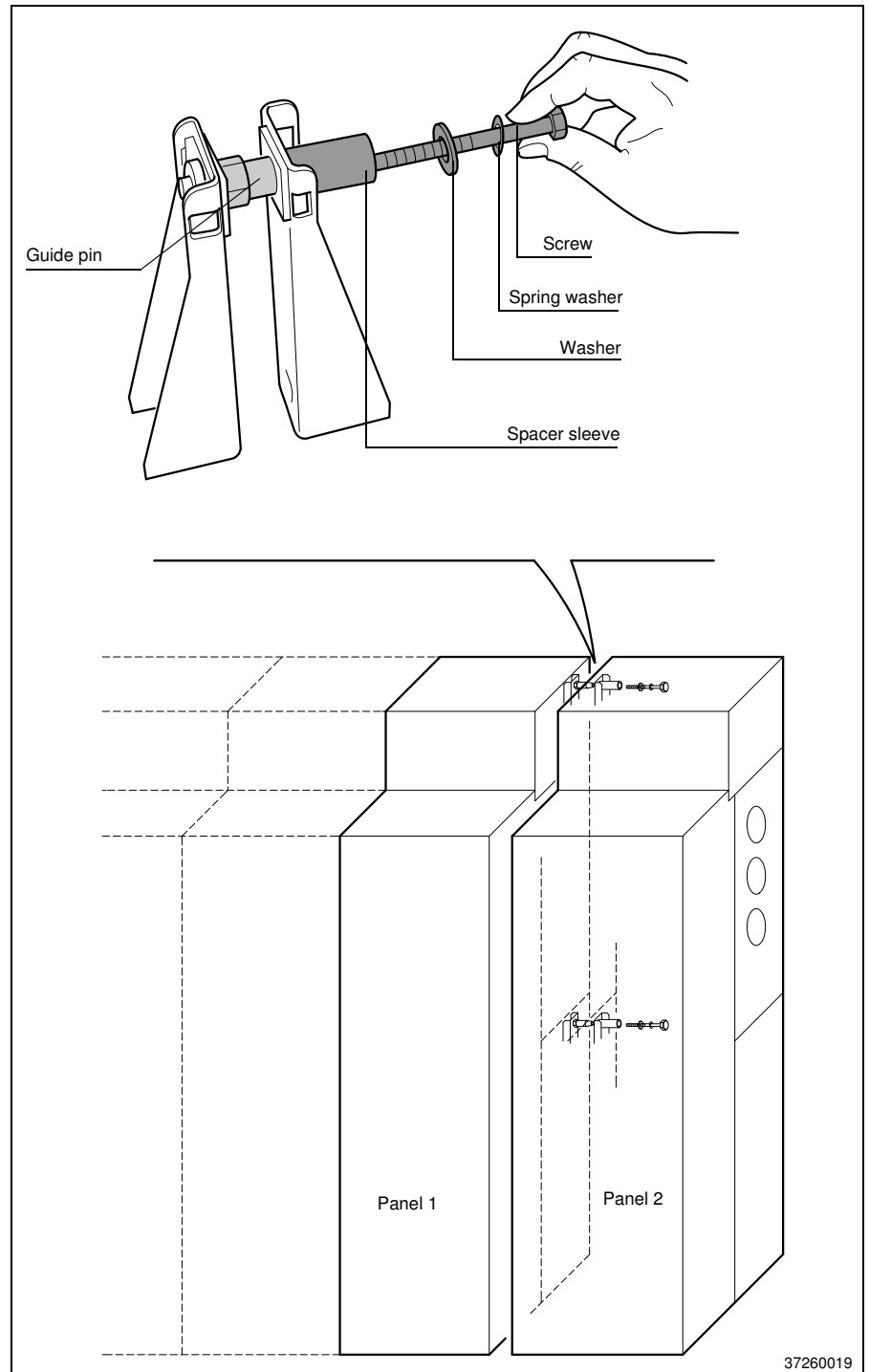

Fig. 32

**16.** As a protection against dust and moisture, close the bores for cable bushings in the adjoined side walls of the operator covers with flexible plugs. Thereby use one plug each for two adjoining openings (Fig. 33).

**17.** Connect the adjacent side walls of the cable connection compartment of panels 1 and 2 according to Fig. 33.

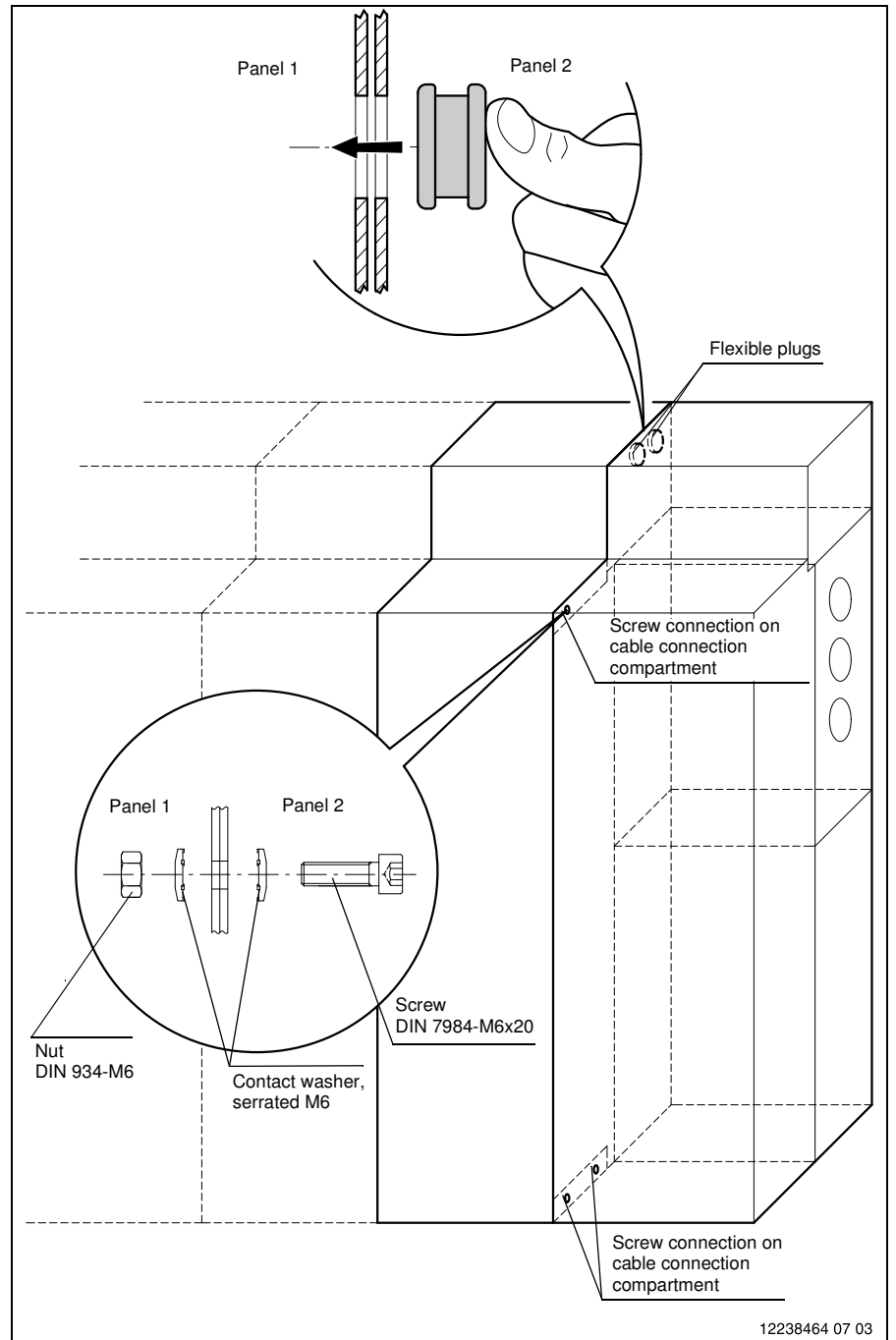

Fig. 33

12238464 07 03

**Note!**

Perform assembly step 18 only for accidental arc resistant panels.

**18.** Assembly of the busbar covering sheet in the upper part of the cable connection compartment takes place in reverse order to assembly step 2.

**Attention!**

The busbar covering sheet must be correctly positioned (Fig. 34) and click into both clip-on clamps in the rear section of the cable connection compartment.

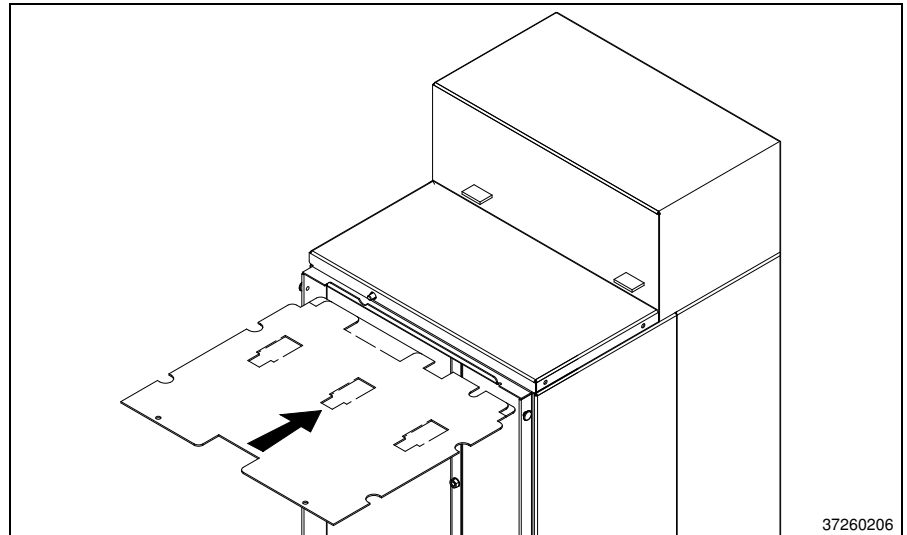

Fig. 34

**19.** Anchor panel 2 to the floor. For the assembly sequence refer to operating instructions for the corresponding GAE panel.

**20.** The procedure for the routing of the voltage supply, the circuit diagrams for the individual assemblies and the earthing can be found in the corresponding chapters of the operating instructions for the respective GAE panel.

**21.** Assembly of cover plate and front panel.



Before the assembly of cover plate and front panel you must check that there are no foreign parts (tools e tc.) inside the switchgear. Leaving loose objects inside the switchgear may cause severe malfunctions.

- The assembly of covering sheet and front panel or relay box is performed in reverse order to assembly steps 4 and 5.
- The bores in the cover plate are additionally closed with the hexagon screws disassembled in assembly step 3 (tightening torque: 25 Nm). The transport angles are not assembled.

### 4.3 Right hand end panel

**1.** Remove the adhesive foil from the bottom panel installation point and turn the plug in with a flat screw driver (tightening torque: 10 Nm) (Fig. 35).

**2.** Assembly of the end seals at the bushings L1 to L3 and on the cable connection compartment is performed as described in assembly steps 1, 2, 4 and 6 and 10 to 12 in chapter 4.1 (Fig. 35).

**3.** Remove the adhesive foils from the top panel installation points and the openings for adjustments and cable bushing. Close the openings with a cap (upper panel installation point) as with a flexible plug (2 cable bushines and 1 adjustment opening) (Fig. 35).

**Note!**

Assembly step 4 does not apply for end panels of type GAE630 -1TS-/4/ and GAE630 -1LSV-/5/.

**4.** Assembly of the stiffening and non-welding protection plates according to assembly steps 7 and 8 in chapter 4.1.

**5.** Assembly of the front covers according to assembly step 9 in chapter 4.1.

### 4.4 Cable connection technology

- The cable connection technology can be found in the corresponding documentation for the cable sets.
- Information concerning the connection of the transformer output panels can be found in the assembly instructions „Fuse Arrangement“, order no.: 21015575.

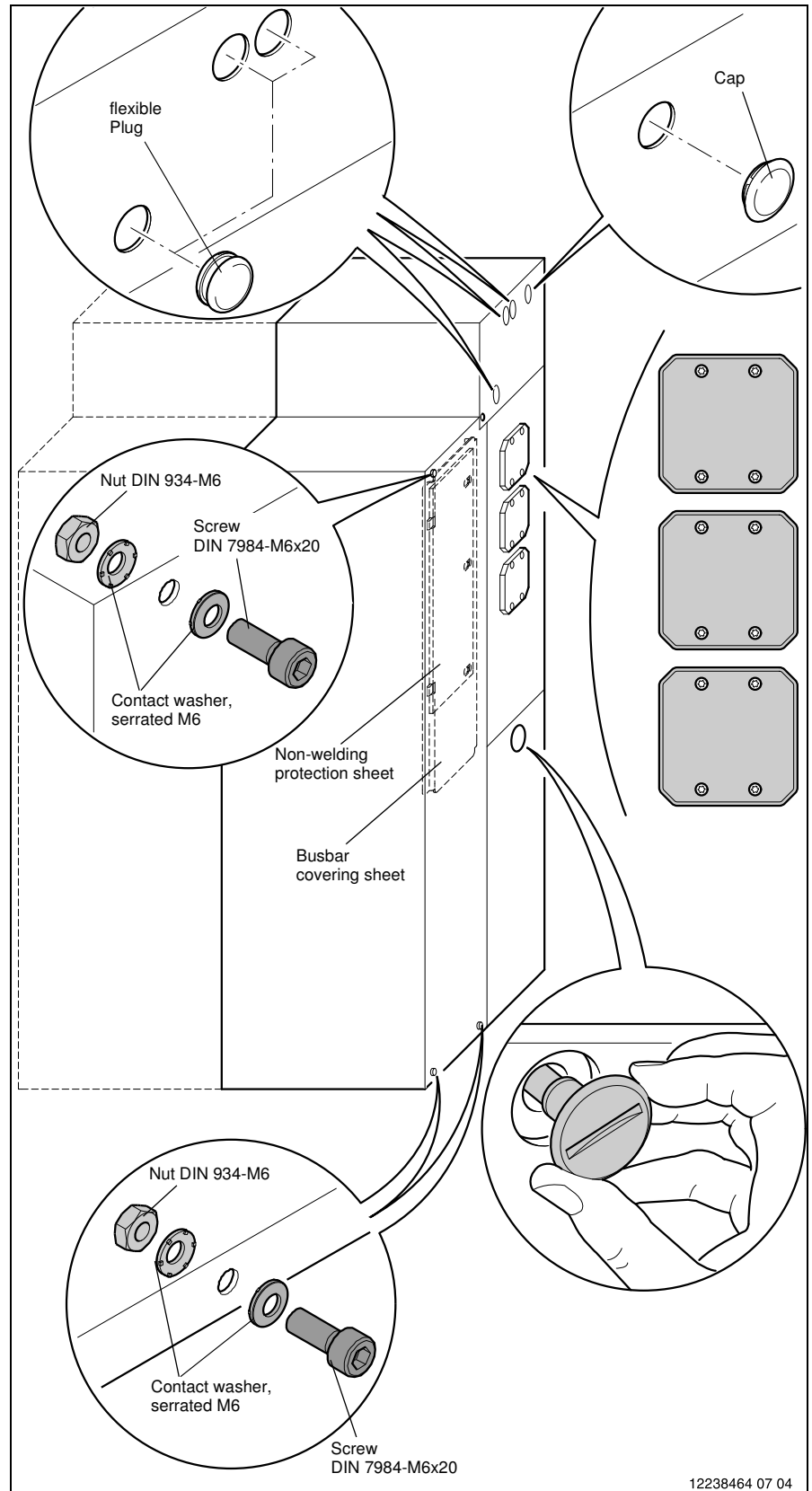

Fig. 35

## 5 Tightening torques

Thread Nominal diameter	Screw joints Strength class 8.8	Welded Stud bolts
M5	6 Nm	-
M6	10 Nm	5,9 Nm
M8	25 Nm	14,7 / -0,2 Nm
M10	49 Nm	-
M12	86 Nm	-

**Note!**

The table values do not apply for tightening torques specially mentioned in the documents!

Table 1

## 6 Accessories

Order-No. 12238780	Assembly kit panel installation GAE-Standard/GAE-Standard
Order-No. 12248719	Assembly kit panel installation GAE-Standard – GAE -1M
Order-No. 12238777	Assembly kit end panel
Order-No. 12238779	Extension kit end panel
Order-No. 12263179	Standard-accessories kit
Order-No. 12264056	Assembly kit busbar covering sheet for GA-/GAE-Standard, right
Order-No. 12264058	Assembly kit busbar covering sheet for GA-/GAE-Standard, left
Order-No. 12264696	Assembly kit busbar covering sheet for GAE, equipment depth 800 mm, right
Order-No. 12264695	Assembly kit busbar covering sheet for GAE, equipment depth 800 mm, left

**Assembly kits for panel installation with metering panels GAE630 1M.../9/**

right hand panel															
GAE630 standard															
left hand panel															
GAE630 standard															
GAE630	-1M2(5)(6)-/9/	on request	-1M2(5)(6)-/9/	-1H2-/9/	-1H1-/4/	-1M3-/4/	-1E1-/4/	-1K-/3/, -1A1-/4/, -2K-/8/, -3K-/10/	-1KG-/4/	-1KB-/4/	-1TS-/4/, -2TS-/8/, -3KB-/12/	-1LSV-/5/, -1LSF-/6/	-1LSVG-/5/, -1LSFG-/6/	end panel	
	-1M1(5Ü)-/9/	on request													
	-1H2-/9/														
	-1H1-/4/								assembly in factory						
	-1M3-/4/														
	-1E1-/4/														
	-1K-/3/, -1A1-/4/, -2K-/8/, -3K-/10/														
	-1KG-/4/														
	-1KB-/4/														
	-1TS-/4/, -2TS-/8/, -3KB-/12/														
	-1LSV-/5/, -1LSF-/6/														
	-1LSVG-/5/, -1LSFG-/6/														
	2K1TS-/10/														
	2K1LSF-/10/														
	end panel														

Assembly kit	Colour marking	Material number
1	white	12238780
3	red	12248719
6	green	12238777





**Ormazabal Anlagentechnik GmbH**

Am Neuerhof 31  
D-47804 Krefeld

Tel.: +49 2151 7151-0  
Fax: +49 2151 7151-75  
E-Mail: [anlagentechnik@ormazabal.de](mailto:anlagentechnik@ormazabal.de)  
Internet: [www.ormazabal.de](http://www.ormazabal.de)