



	Formblatt		
	Freigabeseite Produktinformationen		
Datum: 15.08.2016	Revision: 3	Seite: 1 von 1	Fbl_423-5-1

Produkt:	MUTARS® Proximal Femur System
Dokumenten-Nr.:	Stand: 21.10.2021

Dokumententyp			
Broschüre:	<input type="checkbox"/>	OP-Technik:	<input type="checkbox"/>
Flyer:	<input type="checkbox"/>	Patienteninformation:	<input type="checkbox"/>
Werbeanzeige:	<input type="checkbox"/>	Newsletter:	<input type="checkbox"/>
Information Website:	<input type="checkbox"/>	Gebrauchsinformation:	<input type="checkbox"/>
Produktbeschreibung:	<input checked="" type="checkbox"/>	Produktliste:	<input type="checkbox"/>
Äquivalenzvergleich	<input type="checkbox"/>	Sonstiges:	

Freigabe			
Erstellung	A. Kerber Name	21.10.2021 Datum	 Unterschrift
PM	 Name	25.10.21 Datum	 Unterschrift
F&E (außer Patienten- informationen, Newsletter, Werbeanzeigen)	P. Scheinemann Name	25. OKT. 2021 Datum	 Unterschrift
RA (ic)	J. Höppner Name	27. OKT. 2021 Datum	 Unterschrift
RA (jur. Hersteller) (nur Vertriebsprodukte)	Name	Datum	Unterschrift

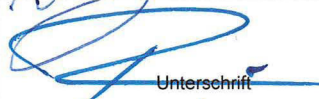
Beschreibung der Änderungen zur Vorversion
Neuerstellung

PART OF THE
TECHNICAL DOCUMENTATION

PRODUCT DESCRIPTION
**MUTARS[®] PROXIMAL FEMUR
SYSTEM**

PRODUCT-GROUP: REVISION AND TUMOR
ARTHROPLASTY

RISK-CLASS: III

LOCATION: HIP

DATE: 21.10.2021, REV. 0

1 TABLE OF CONTENTS

1	MUTARS® Proximal Femur System	4
2	Intended Use	8
3	Qualification of the Product as a Medical Device	8
4	Risk-class: III	8
5	Intended User	8
6	Target Group	8
7	Indications	9
8	Contraindications	9
9	Risk Factors	9
10	Design Description	10
10.1	MUTARS® Prox. Femur	10
10.2	MUTARS® Prox. Femur Revision and trochanter plates for MUTARS® proximal femur revision	11
10.3	MUTARS® Extension Piece	14
10.4	MUTARS® Connecting Part and MUTARS® screw for connecting part	15
10.5	MUTARS® Reducer	17
10.6	MUTARS® Screw and MUTARS® Safety Screw	19
10.7	MUTARS® End Piece	20
10.8	MUTARS® RS Coupling Device and MUTARS® Screw for RS Coupling Device	21
10.9	MUTARS® intramed. connecting module for KRI	22
10.10	MUTARS® intramed. connecting module for GenuX® MK femur and the MUTARS® intramed. connecting module for GenuX® femur	23
10.11	MUTARS® HMRS Adapters	25
11	Materials	25
12	Coatings / Surfaces	26
13	Sizes and Dimensions	36
13.1	MUTARS® prox. femur	36
13.2	MUTARS® prox. femur revision and trochanter plates for MUTARS® proximal femur revision 37	
13.3	MUTARS® extension piece	39
13.4	MUTARS® connecting part and MUTARS® screw for connecting part	40
13.5	MUTARS® reducer	41
13.6	MUTARS® screw and MUTARS® safety screw	42
13.7	MUTARS® end piece	44
13.8	MUTARS® RS coupling device and MUTARS® screw for RS coupling device	45
13.9	MUTARS® intramed. connecting module for KRI	46



13.10	MUTARS® intramed. connecting module for GenuX® MK femur and the MUTARS® intramed. connecting module for GenuX® femur	47
13.11	MUTARS® HMRS adapter	50
14	Compatibility	51
15	Warnings	51
16	Product List (Identification of the Products)	51
17	Reference to Previous Generations and Similar Devices	51
18	LIST OF FIGURES	52
19	LIST OF TABLES	54
20	LIST OF ABBREVIATIONS	55
2	DOCUMENT REVISION HISTORY	56

1 MUTARS® Proximal Femur System

The **MUTARS® Proximal Femur System** is a modular proximal femur replacement system offering various components that can be combined (with each other) to replace the proximal femur and address major bone defects with various options depending upon the size and location of the defects of each patient. The MUTARS® Proximal Femur System includes the following components:

- MUTARS® prox. femur,
- MUTARS® prox. femur revision and Trochanter plate for MUTARS® proximal femur revision
- MUTARS® extension pieces,
- MUTARS® connecting part,
- MUTARS® screws,
- MUTARS® femoral stems (cf. “Product Description_MUTARS Femoral Stems”),
- MUTARS® end piece,
- MUTARS® reducer,
- Connection adapters (MUTARS® HMRS adapters).

The *MUTARS® intramedullary connecting modules* intended for use in cases of intramedullary femur replacement and the *MUTARS® RS coupling devise* providing coupling of components with the MUTARS® female cylindrical fit connection to components with the MUTARS® male taper connection (e.g. MUTARS® RS stems, MUTARS® intramedullary connecting modules) are also described in this product description.

The individual components are connected by means of the MUTARS® cylindrical fit and serration connection and a connecting screw.

The MUTARS® cylindrical fit and serration connection is provided by a precise male ($\text{Ø } 16 \text{ g6 } \left(\begin{smallmatrix} -0,006 \\ -0,017 \end{smallmatrix} \right)$) / female ($\text{Ø } 16 \text{ H7 } \left(\begin{smallmatrix} +0,018 \\ 0 \end{smallmatrix} \right)$) cylindrical fit and a serration of interdigitating 72 teeth to provide rotational stability. A connecting screw is axially applied across the connection during component assembly to connect and secure the MUTARS® cylindrical fit connection.

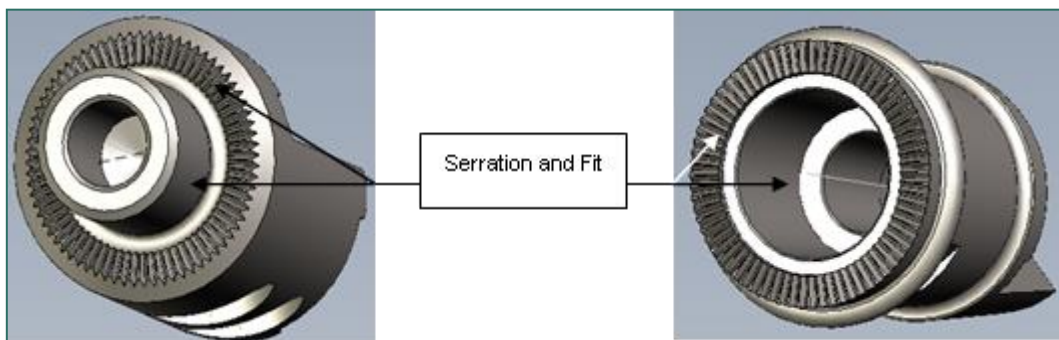

FIGURE 1. MUTARS® CYLINDRICAL FIT AND SERRATION CONNECTION

The individual components are further described in Sections 10 to 13.



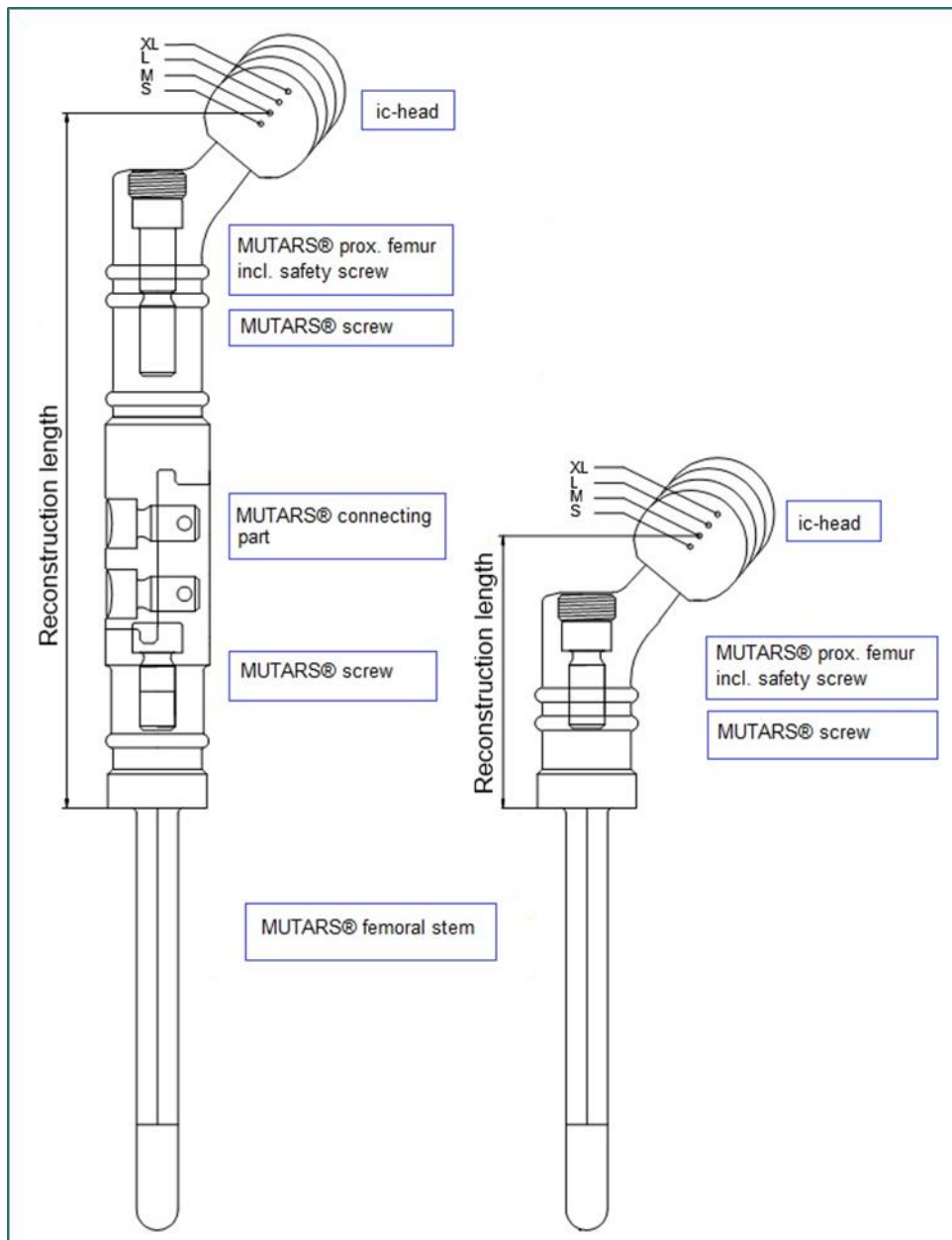

FIGURE 4. MUTARS® PROX. FEMUR WITH MUTARS® FEMORAL STEM. ON THE LEFT WITH MUTARS® CONNECTING PART.

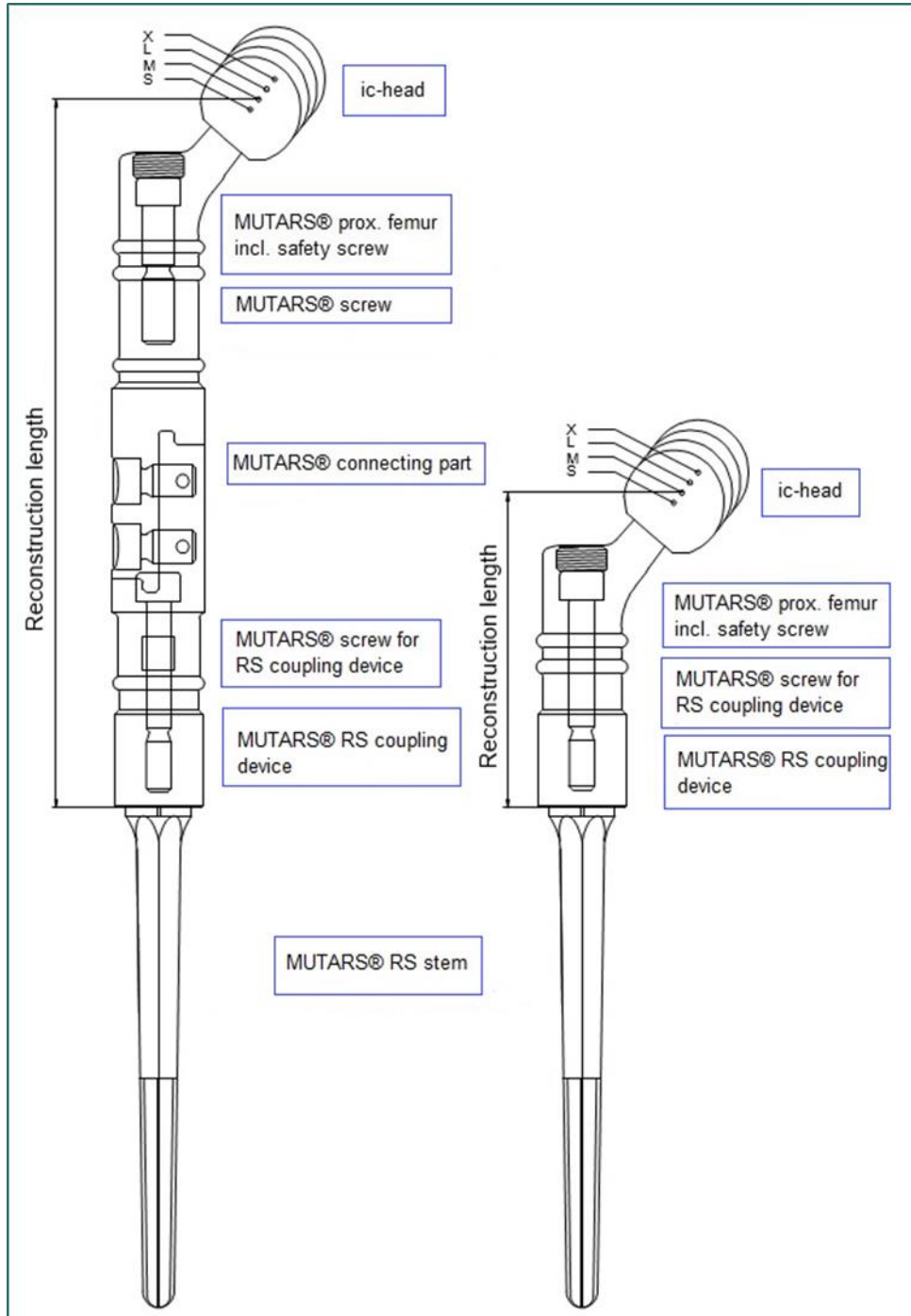

FIGURE 5. MUTARS® PROX. FEMUR WITH MUTARS® RS STEM AND MUTARS® RS COUPLING DEVICE. ON THE LEFT WITH MUTARS® CONNECTING PART.

2 Intended Use

⇒ See Doc. “Fbl_423-1-2-4_Zweckbestimmung_MUTARS® Hip” in the folder “03 Produktbeschreibung”

3 Qualification of the Product as a Medical Device

The components of the MUTARS® Proximal Femur System are medical devices in accordance with the definitions in Article 2 of the Medical Device Regulations MDR (EU) 2017/745 of 05. April 2017. The components of the MUTARS® Proximal Femur System are “medical devices” “for human beings for the specific medical purposes” as described in the Article 2 under (1) of the of the Medical Device Regulations MDR (EU) 2017/745 of 05. April 2017.

4 Risk-class: III

The components of the MUTARS® Proximal Femur System are classified in risk class III in accordance with the classification rules in Annex VIII of the Medical Device Regulations MDR (EU) 2017/745 of 05. April 2017. The risk class is justified as the components of the MUTARS® Proximal Femur System meet the Rule 8 in 5.4 of the Medical Device Regulations MDR (EU) 2017/745 that they are total or partial joint replacement.

The *Trochanter plate for MUTARS® proximal femur revision* is classified in risk class IIb in accordance with the classification rules in Annex VIII of the Medical Device Regulations MDR (EU) 2017/745 of 05. April 2017. The risk class is justified as the *Trochanter plate for MUTARS® proximal femur revision* meets the Rule 8 in 5.4 of the Medical Device Regulations MDR (EU) 2017/745.

5 Intended User

The use of these implants is restricted to persons who, based on their education, knowledge and practical experience, are capable of proper handling and use of the device. Familiarity with the recommended surgical technique and its careful application as well as a pre-operative planning are essential to achieve the best possible outcome. The implantcast GmbH offers special user trainings to ensure an optimal preparation.

6 Target Group

The target population corresponds to the population likely to benefit from the product in indication for joint replacement. Finally, the surgeon decides whether and which version of prosthesis for the individual

patient is suitable. This decision depends on several factors, such as the age and the patient's weight, bone quality, shape of the bone, patient's physical activity levels and deformation of the joint. The provision of prostheses is generally indicated only in patients whose skeleton is fully grown.

7 Indications

Information about indications of the MUTARS® Proximal Femur System can be found in the Instruction for Use.

- ⇒ See Doc. Instruction for Use “09300013 MUTARS Tumor- und Revisionsystem” in the folder “04 Gebrauchsinformation”

8 Contraindications

Information about contraindications of the MUTARS® Proximal Femur System can be found in the Instruction for Use.

- ⇒ See Doc. Instruction for Use “09300013 MUTARS Tumor- und Revisionsystem” in the folder “04 Gebrauchsinformation”

9 Risk Factors

Information about risk factors of the MUTARS® Proximal Femur System can be found in the Instruction for Use.

- ⇒ See Doc. Instruction for Use “09300013 MUTARS Tumor- und Revisionsystem” in the folder “04 Gebrauchsinformation”
-



10 Design Description

10.1 MUTARS® Prox. Femur

The *MUTARS® prox. femur* is a femoral component that replaces the proximal part of the femur including the femoral neck.

The *MUTARS® prox. femur* is an extrasosseous component with a cylindrical cross-section and a CCD angle of 140°. The *MUTARS® prox. femur* has retention rings (cf. FIGURE 6) for securing the attachment tube.

The *MUTARS® prox. femur* features a 12/14 Morse-type taper trunnion for connection to a femoral head. The taper has an angle of 5.7°, a length of 13.5 mm, roundness of 0.008 µm, and straightness of 0.003 µm. The taper has a machine turned surface finish producing circular microgrooves to provide a roughness of Rz of 6 + 14 µm.

The *MUTARS® prox. femur* utilizes a female cylindrical fit and serration connection at its distal end for attachment to other system components incorporating a matching male cylindrical fit connection and serration. The serration allows for an adjustment of the antetorsion angle in 5° increments.



FIGURE 6. MUTARS® PROX. FEMUR INCL. SAFETY SCREW



FIGURE 7. 12/14 MORSE-TYPE TAPER TRUNNION AND THREADED HOLE FOR THE SAFETY SCREW



FIGURE 8. MUTARS® PROX. FEMUR INCL. SAFETY SCREW – ROTATIONAL ADJUSTMENT

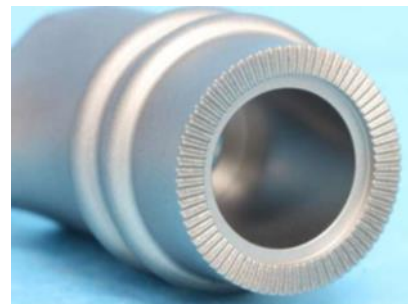

FIGURE 9. FEMALE CYLINDRICAL FIT AND SERRATION CONNECTION

10.2 MUTARS® Prox. Femur Revision and trochanter plates for MUTARS® proximal femur revision

The *MUTARS® prox. femur revision* is a femoral component that replaces the proximal part of the femur including the femoral neck. The *MUTARS® prox. femur revision* is an extrasosseous component with a trochanter major like curvature which allows for attachment of trochanteric bone and/or soft tissue. For this purpose various lateral and medial holes and notches are incorporated. If trochanteric bone can be

salvaged it can be fixed to the lateral porous part (cf. FIGURE 11) of the *MUTARS® prox. femur revision* by means of an additional trochanter plate. The trochanter plate is attached to the *MUTARS® prox. femur revision* with cerclages (made of different materials in multifilament form) (cf. FIGURE 12).

The *MUTARS® prox. femur revision* is available in two lengths and two CCD angles (125° and 135°).

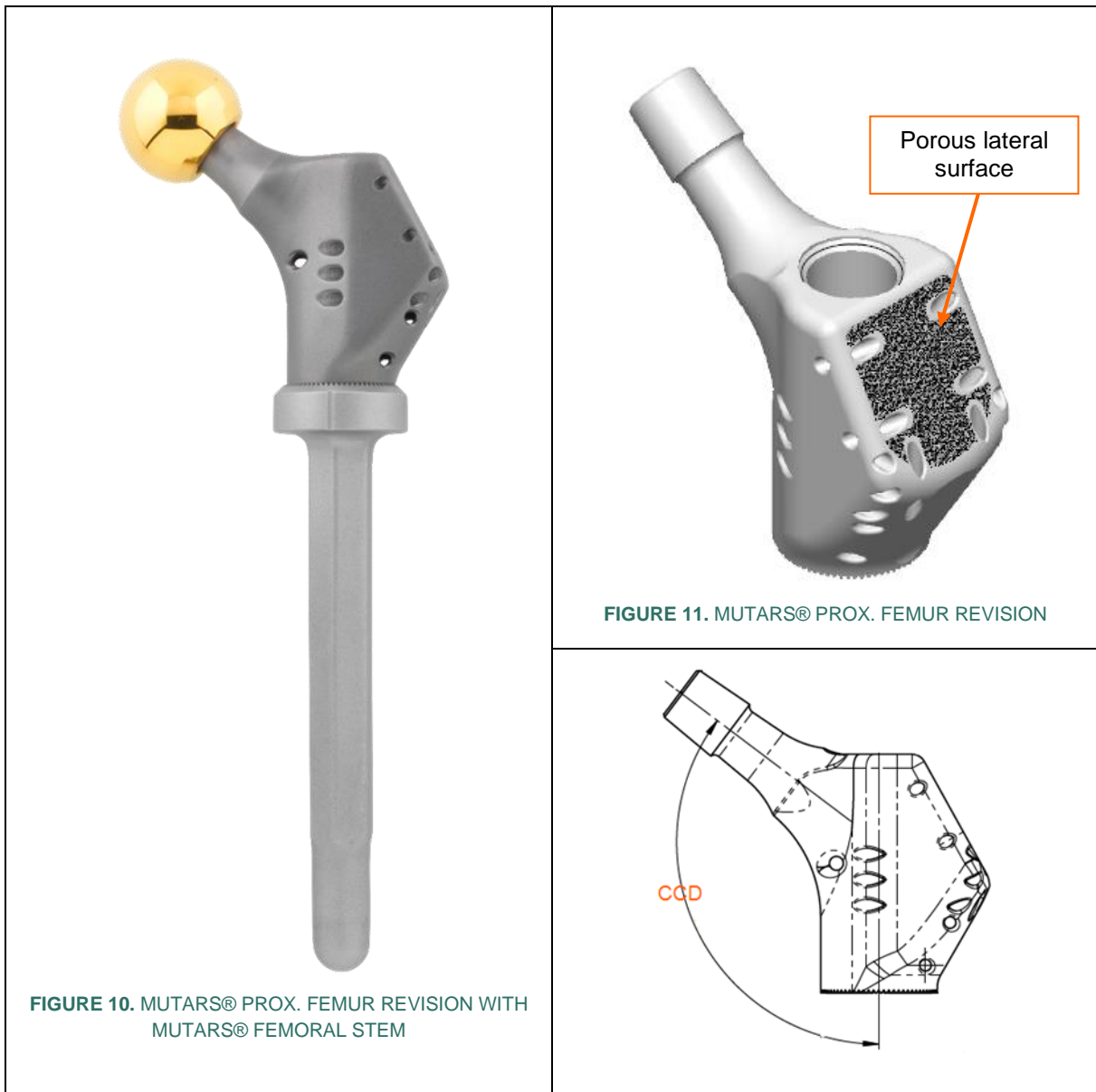

The *MUTARS® prox. femur revision* features a 12/14 Morse-type taper trunnion for connection to a femoral head. The taper has an angle of 5.7°, a length of 13.5 mm, roundness of 0.008 µm, and

straightness of 0.003 μm . The taper has a machine turned surface finish producing circular microgrooves to provide a roughness of Rz of $6 + 14 \mu\text{m}$.

The *MUTARS® prox. femur revision* utilizes a female cylindrical fit and serration connection at its distal end for attachment to other *MUTARS®* hip system components incorporating a matching male cylindrical fit connection. The serrated teeth allow for an adjustment of the antetorsion angle in 5° increments.

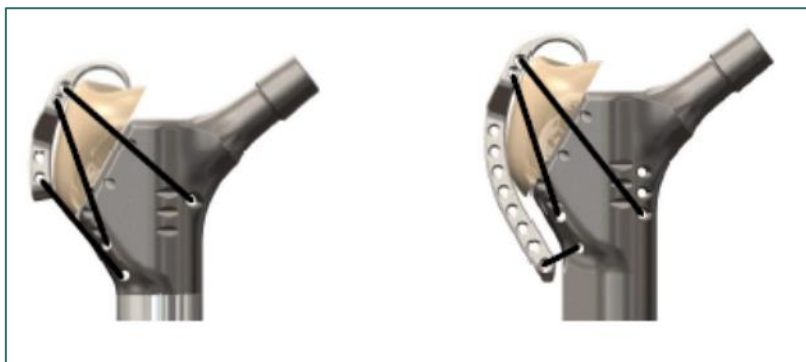

FIGURE 12. *MUTARS®* PROX. FEMUR REVISION WITH TROCHANTERIC BONE AND TROCHANTER PLATE

The *Trochanter plate for MUTARS® proximal femur revision short* incorporates two (2) proximal and two (2) distal holes for cerclages, while the *Trochanter plate for MUTARS® proximal femur revision long* incorporates (8) distal holes for cerclages. Both plates also have a hole at the trochanteric end for attachment of the impactor. Two sharp proximal hooks ensure the fixation.



FIGURE 13. TROCHANTER PLATE FOR MUTARS® PROXIMAL FEMUR REVISION LONG

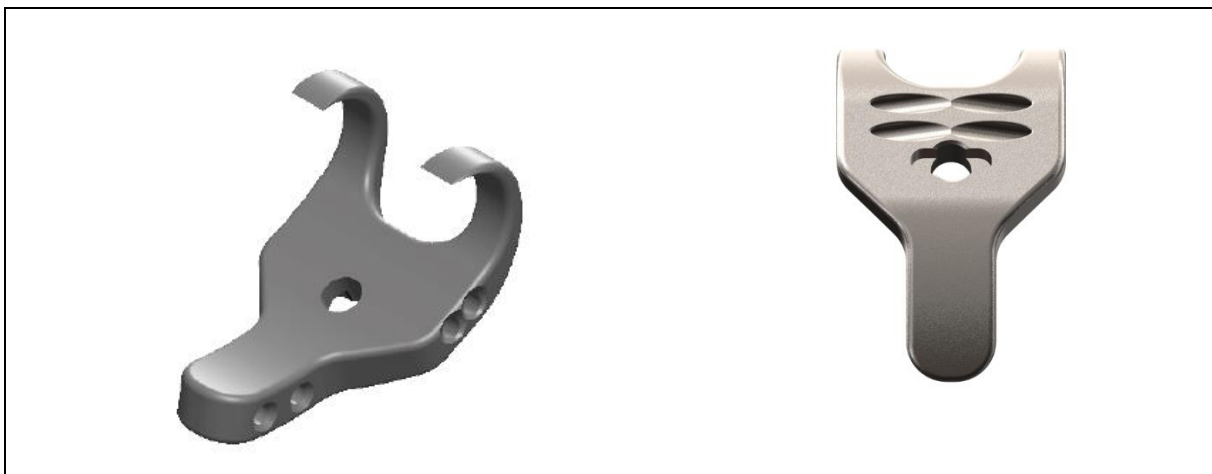

FIGURE 14. TROCHANTER PLATE FOR MUTARS® PROXIMAL FEMUR REVISION SHORT

10.3 MUTARS® Extension Piece

The *MUTARS® extension piece* is an optional component that serves as an extraosseous length adjustment for bridging of bone defects (cf. FIGURE 2). The extension piece has a cylindrical cross-section and retention rings for securing the attachment tube (cf. FIGURE 15).

The *MUTARS® extension piece* utilizes a male cylindrical fit and serration connection at its proximal end for attachment to other system components incorporating a matching female cylindrical fit

connection and a female cylindrical fit and serration connection at its distal end for attachment to other system components incorporating a matching male cylindrical fit connection (cf. FIGURE 16). The *MUTARS® PT extension piece* features a shorter length of the cylindrical fit (18 mm instead of 23.5mm).

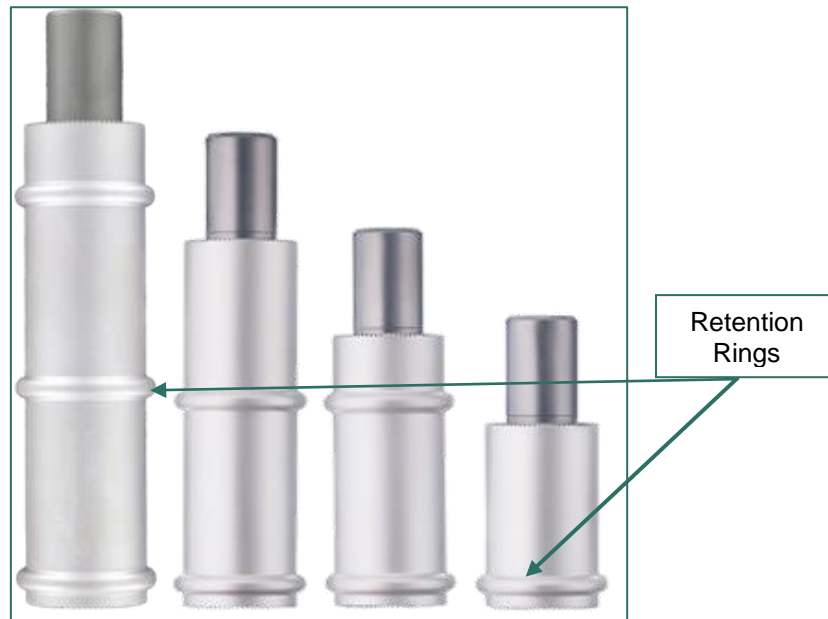

FIGURE 15. MUTARS® EXTENSION PIECES



FIGURE 16. MALE CYLINDRICAL FIT AND SERRATION CONNECTION (LEFT PICTURE); FEMALE CYLINDRICAL FIT AND SERRATION CONNECTION (RIGHT PICTURE)

10.4 MUTARS® Connecting Part and MUTARS® screw for connecting part

Like the *MUTARS® extension piece*, the *MUTARS® connecting part* serves as an extraosseous length adjustment for bridging of bone defects (cf. FIGURE 4).

The connecting part consists of two parts: the *MUTARS® connecting part distal* and *MUTARS® connecting part proximal* (FIGURE 17). The two parts are connected to each other with two *MUTARS® screws for connecting part* (FIGURE 18). The connecting part has one retention ring for securing the attachment tube.

The *MUTARS® connecting part* utilizes a male cylindrical fit and serration connection at its proximal end for attachment to other system components incorporating a matching female cylindrical fit connection and a female cylindrical fit and serration connection at its distal end for attachment to other system components incorporating a matching male cylindrical fit connection.

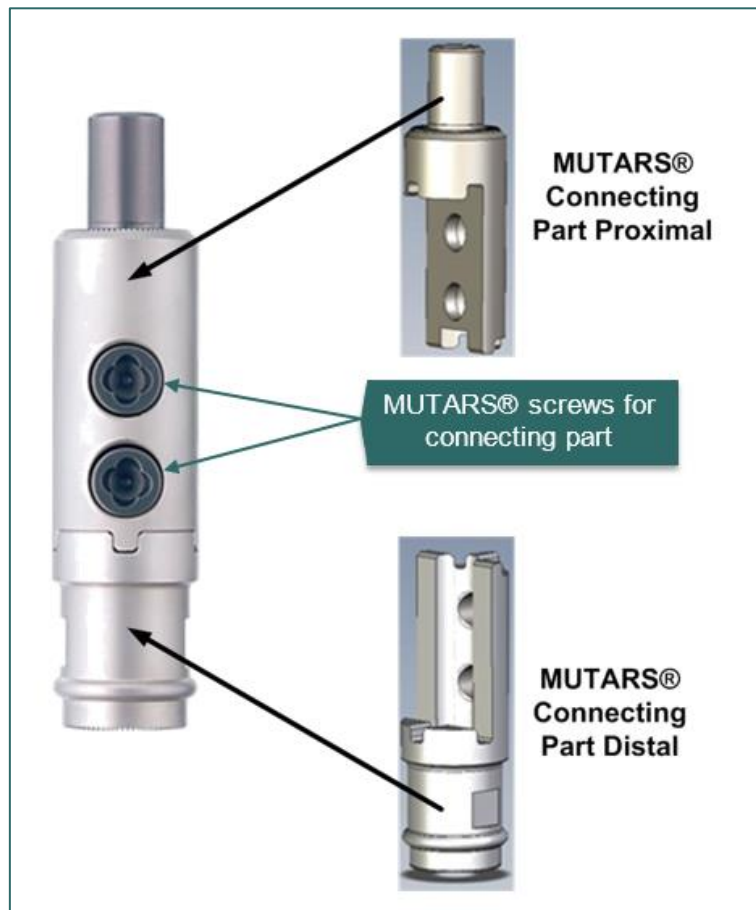

FIGURE 17. MUTARS® CONNECTING PART

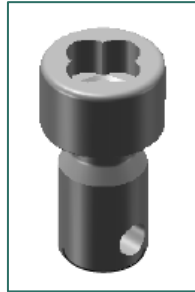

FIGURE 18. MUTARS® SCREW FOR CONNECTING PART

10.5 MUTARS® Reducer

The *MUTARS® reducer* is for the extraosseous length adjustment in cases of total femur replacement (e.g. FIGURE 21). The *MUTARS® reducer* utilizes a male cylindrical fit and serration connection for attachment to other system components incorporating a matching female cylindrical fit connection. The *MUTARS® PT reducer* features a shorter length of the cylindrical fit (18 mm instead of 23.5mm).

The *MUTARS® reducer* has one retention ring for securing the attachment tube.



FIGURE 19. MUTARS® REDUCER

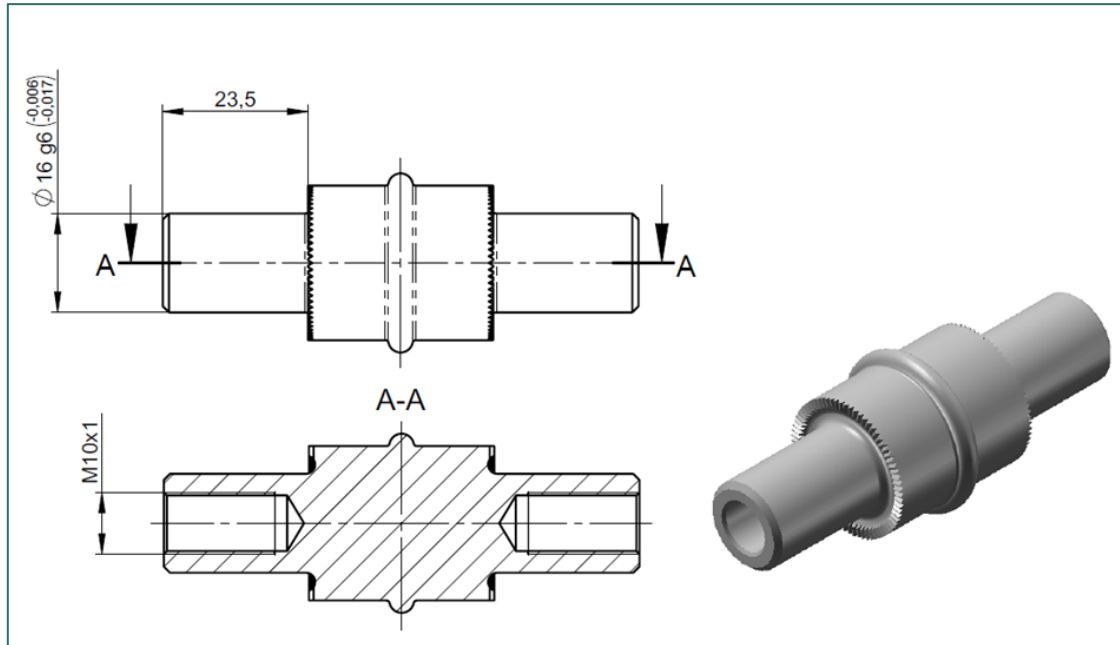

FIGURE 20. MUTARS® REDUCER



FIGURE 21. MUTARS® TOTAL FEMUR MK

10.6 MUTARS® Screw and MUTARS® Safety Screw

The *MUTARS® screw* (FIGURE 22, left picture) connects and secures the different system components together (i.e. prox. femur, extension piece, connecting part and femoral stem). Due to the various length adjustments within the MUTARS® Proximal Femur Replacement System, the screw is available in different sizes in order to connect the full prosthesis length.

The *MUTARS® safety screw* (FIGURE 22, right picture) is intended to hold the *MUTARS screw* in place and prevent the connection screw from backing out (lock screw).



FIGURE 22. MUTARS® SCREW (LEFT PICTURE); MUTARS® SAFETY SCREW (RIGHT PICTURE)

10.7 MUTARS® End Piece

The *MUTARS® end piece* (FIGURE 23) is used in rare cases of bone tumors and bone metastases in which no full extremity preserving surgery can be carried out. In combination with the *MUTARS® Proximal Femur Replacement* component or the *MUTARS® Proximal Tibia Replacement* component, the end piece can serve to prosthetically preserve a terminal femoral or tibial stump, respectively. The end piece may also be used to cap a *Distal Femur Replacement* component in cases that may not be able to accept a femoral stem due to lack of sufficient femoral bone or in cases of on-going metastatic disease that require the removal of a previously implanted *MUTARS® femoral stem* but in which the surgeon desires to maintain the prosthetic knee joint for future reconstruction by leaving the prosthetic *MUTARS® knee joint* components in situ.

The *MUTARS® end piece* utilizes a male cylindrical fit and serration connection for attachment to the proximal or distal femur replacement (or proximal tibia replacement) component or with a *MUTARS® extension piece* to achieve a functional length adjustment to the stump terminus.



FIGURE 23. MUTARS® END PIECE

10.8 MUTARS® RS Coupling Device and MUTARS® Screw for RS Coupling Device

The *MUTARS® RS coupling device* (FIGURE 24) provides coupling of a component with the MUTARS® male taper connection to a component with the MUTARS® female cylindrical fit connection (cf. FIGURE 5). For this purpose the coupling device has the MUTARS® female taper connection (the taper has an angle of $5.72^{\circ} \pm 0.05^{\circ}$ and $\varnothing 14.8 \begin{pmatrix} -0,05 \\ -0,10 \end{pmatrix}$ mm) at its one end and the MUTARS® male cylindrical fit and serration connection at its other end.

An 8 mm diameter screw (*MUTARS® screw for RS coupling device*; FIGURE 25) is axially applied across the connection during components assembly to secure the connection.



FIGURE 24. MUTARS® RS COUPLING DEVICE



FIGURE 25. MUTARS® SCREW FOR RS COUPLING DEVICE FOR RS COUPLING DEVICE

10.9 MUTARS® intramed. connecting module for KRI

The *MUTARS® intramed. (intramedullary) connecting module for KRI* is used in cases of intramedullary femur replacement in which the femoral diaphysis is preserved and the proximal femur and knee joint are replaced by endoprostheses, which are then connected using this intramedullary rod. The intramedullary connecting module is placed into the reamed medullary cavity and therefore allows for a bone preserving surgery. The rib profile provides rotational stability. It utilizes the MUTARS® male taper connection (taper angle of $5.72^{\circ} \pm 0.05^{\circ}$; $\varnothing 14.8 \left(\begin{smallmatrix} +0.05 \\ 0 \end{smallmatrix} \right)$ mm) for attachment to MUTARS® KRI (MOM / HD) ant to MUTARS® RS coupling device or MUTARS® RS metaphyseal component.

The *MUTARS® intramed. connecting module for KRI* is intended to be used without bone cement.

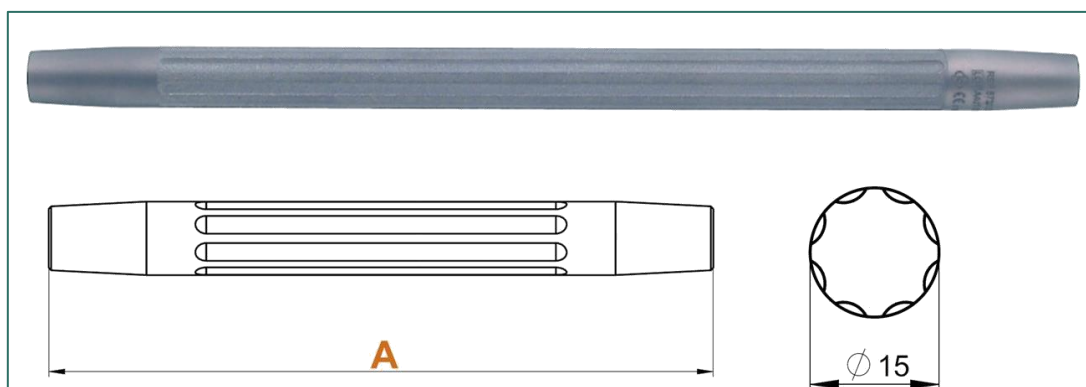

FIGURE 26. MUTARS® INTRAMED. (INTRAMEDULLARY) CONNECTING MODULE FOR KRI

10.10 MUTARS® intramed. connecting module for GenuX® MK femur and the MUTARS® intramed. connecting module for GenuX® femur

The *MUTARS® intramed. (intramedullary) connecting module for GenuX® MK femur* has the same design characteristics as the *MUTARS® intramedullary connecting module for KRI*. The only difference is that the *MUTARS® intramed. connecting module for GenuX® MK femur* is designed to be connected to the *MUTARS® GenuX® MK Femur* (cf. FIGURE 30) instead of the *MUTARS® KRI*. For this reason it provides the *MUTARS® male taper connection* (taper angle of $5.72^{\circ} \pm 0.05^{\circ}$; $\varnothing 14.8 \left(\begin{smallmatrix} +0.05 \\ 0 \end{smallmatrix} \right)$ mm) at its one end and a *female cylindrical fit* ($\varnothing 12 \text{ H7} \left(\begin{smallmatrix} +0.018 \\ 0 \end{smallmatrix} \right)$) and a *female taper connection* (taper angle of $3^{\circ}1'18'' \pm 0^{\circ}5'0''$ and $\varnothing 9.99 \pm 0.02$ mm) at its other end.

The *MUTARS® intramed. connecting module for GenuX® femur* has the same design characteristics as the *MUTARS® intramedullary connecting module for KRI*. The only difference is that the *MUTARS® intramed. connecting module for GenuX® femur* is designed to be connected to the *MUTARS® GenuX® Femur* instead of the *MUTARS® KRI*. For this reason it provides the *MUTARS® male taper connection* (taper angle of $5.72^{\circ} \pm 0.05^{\circ}$; $\varnothing 14.8 \left(\begin{smallmatrix} +0.05 \\ 0 \end{smallmatrix} \right)$ mm) at its one end and a *female cylindrical fit* ($\varnothing 14 \text{ H7} \left(\begin{smallmatrix} +0.018 \\ 0 \end{smallmatrix} \right)$) and a *female taper connection* (taper angle of $3^{\circ}1'18'' \pm 0^{\circ}5'0''$ and $\varnothing 12 \pm 0.02$ mm) at its other end.

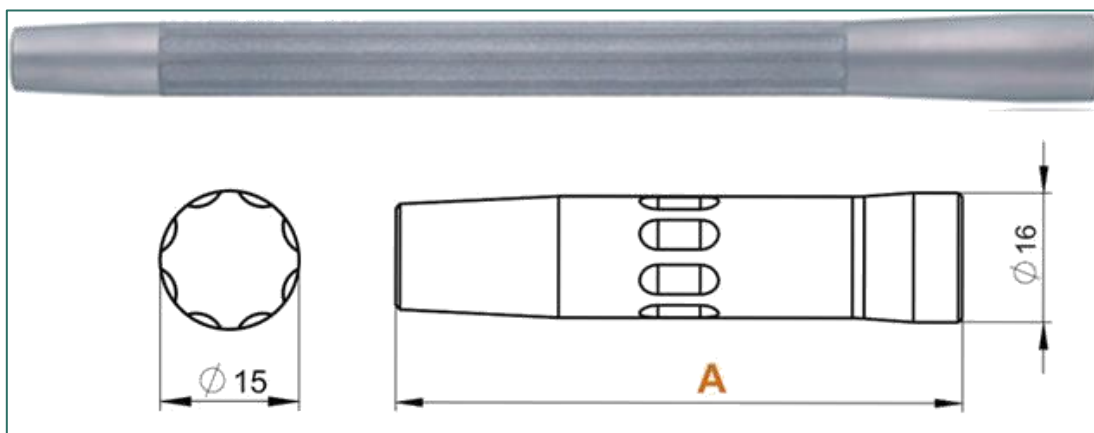

FIGURE 27. MUTARS® INTRAMED. CONNECTING MODULE FOR GENUX® MK FEMUR

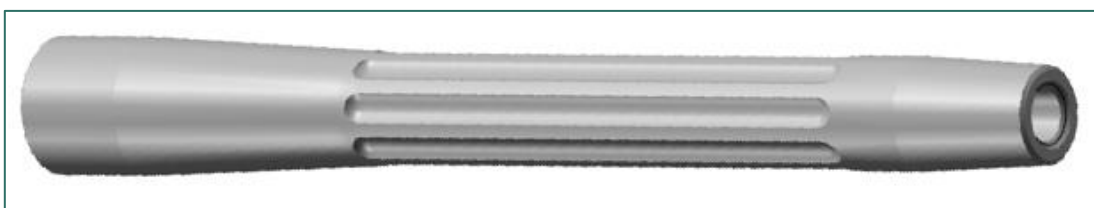

FIGURE 28. MUTARS® INTRAMED. CONNECTING MODULE FOR GENUX® FEMUR

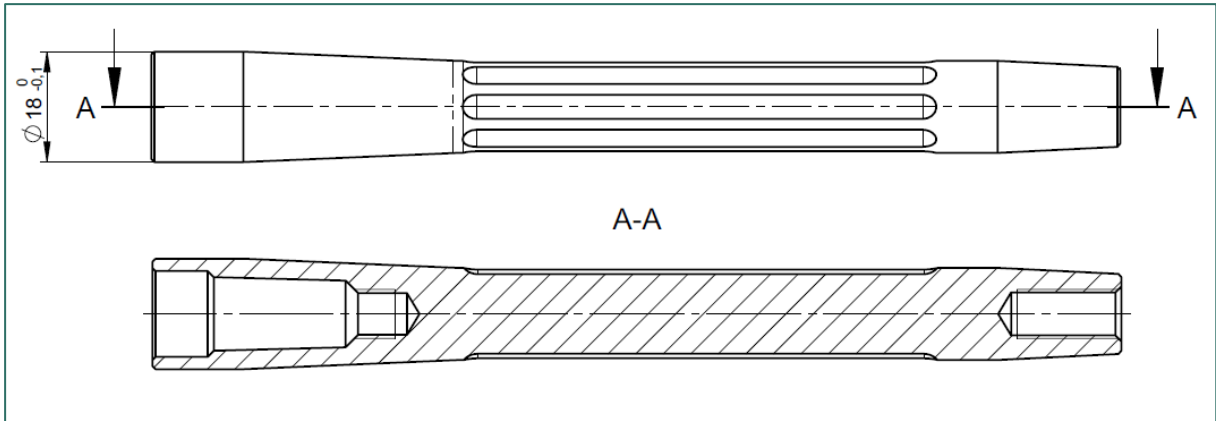

FIGURE 29. MUTARS® INTRAMED. CONNECTING MODULE FOR GENUX® FEMUR



FIGURE 30. MUTARS® PROX. FEMUR WITH MUTARS® RS COUPLIG DEVICE, MUTARS® INTRAMED. CONNECTING MODULE FOR GENUX® MK FEMUR AND MUTARS® GENUX® MK

10.11 MUTARS® HMRS Adapters

The *MUTARS® HMRS adapter female taper* is intended to connect MUTARS® femoral components with a female MUTARS® cylindrical fit connection to the HMRS System. For this purpose the *MUTARS® HMRS adapter female taper* has the MUTARS® male cylindrical fit and serration connection at its one end and a female taper connection with the taper angle of $5.72^{\circ} \left(\begin{smallmatrix} 0^{\circ} \\ -0,05^{\circ} \end{smallmatrix} \right)$ and $\varnothing 22.8 \pm 0.05$ mm at its other end. The *MUTARS® HMRS adapter female taper* has a straight conical shape.

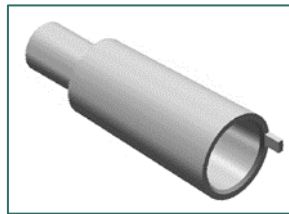

FIGURE 31. MUTARS® HMRS ADAPTER FEMALE TAPER

The *MUTARS® HMRS adapter male taper* is intended to connect MUTARS® femoral components with a male MUTARS® cylindrical fit connection, to the HMRS System. For this purpose the *MUTARS® HMRS adapter male taper* has the MUTARS® female cylindrical fit and serration connection at its one end and a male taper connection with the taper angle of $5.72^{\circ} \pm 0.05^{\circ}$ and $\varnothing 23.05 \pm 0.05$ mm at its other end. The *MUTARS® HMRS adapter male taper* has a straight cylindrical shape.

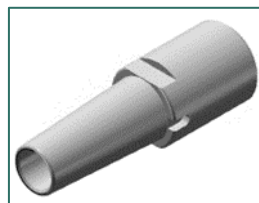

FIGURE 32. MUTARS® HMRS ADAPTER MALE TAPER

11 Materials

The *MUTARS® proximal femur*, *MUTARS® extension piece*, *MUTARS® connection part*, *MUTARS® screw for connecting part*, *MUTARS® screw*, *MUTARS® safety screw*, *MUTARS® end piece*, *MUTARS® reducer*, *MUTARS® RS coupling device*, *MUTARS® screw for RS coupling device*, *MUTARS® intramed. connecting module for KRI*, *MUTARS® intramed. connecting module for GenuX®*

femur, MUTARS® intramed. connecting module for GenuX® MK femur are manufactured from TiAl₆V₄ wrought alloy acc. to ISO 5832-3.

The MUTARS® HMRS adapter female taper and MUTARS® HMRS adapter male taper are manufactured from CoCrMo wrought alloy acc. to ISO 5832-12.

The MUTARS® prox. femur revision and Trochanter plate for MUTARS® proximal femur revision are manufactured using the Electron Beam Melting (EBM) process with TiAl₆V₄ alloy powder.

12 Coatings / Surfaces

The MUTARS® prox. femur, MUTARS® extension piece, MUTARS® connecting part, MUTARS® reducer, and MUTARS® RS coupling device have a sand blasted surface finish. They are available uncoated and with silver coating that is applied circumferentially.

The MUTARS® HMRS adapter female taper, and MUTARS® HMRS adapter male taper are silver coated. The silver coating that is applied circumferentially.

The MUTARS® prox. femur revision has a sand blasted surface finish and incorporates a porous EPORE® structure on its cranio-lateral side. The structure is characterized by a rod thickness of 360 ± 50 µm and features a high affinity with trabecular bone tissue It is available uncoated and with silver coating that is applied circumferentially. The trochanter plates for MUTARS® proximal femur revision have a sand blasted surface finish.

The MUTARS® intramed. connecting module for KRI, MUTARS® intramed. connecting module for GenuX® femur and MUTARS® intramed. connecting module for GenuX® MK femur have a rough corundum blasted surface. They are available uncoated and with silver coating that is applied circumferentially.

The MUTARS® screw, MUTARS® safety screw, MUTARS® screw for connecting part, MUTARS® screw for RS coupling device, MUTARS® filia screw, and MUTARS® filia safety screw have a sand blasted surface.

TABLE 1: COATING SPECIFICATIONS FOR SILVER

CHARACTERISTICS	VALUE	
	Gold (Surface Specification SUR_E1)	Silver (Surface Specification SUR_F1)
APPEARANCE	Sealed golden coating	Silver white, satin metal layer
COATING THICKNESS	>0.2µm AuCo _{0,2} on adhesive layer	15 ± 5 µm

CHARACTERISTICS	VALUE	
	Gold (Surface Specification SUR_E1)	Silver (Surface Specification SUR_F1)
TENSILE STRENGTH	No delamination of coating on implant surface	According to thermal shock equipment DIN EN ISO 4521:2009-1 Annex C-C.6

MUTARS® proximal femur

The *MUTARS® prox. femur* has a sand blasted surface finish. It is available uncoated and with silver coating that is applied circumferentially.

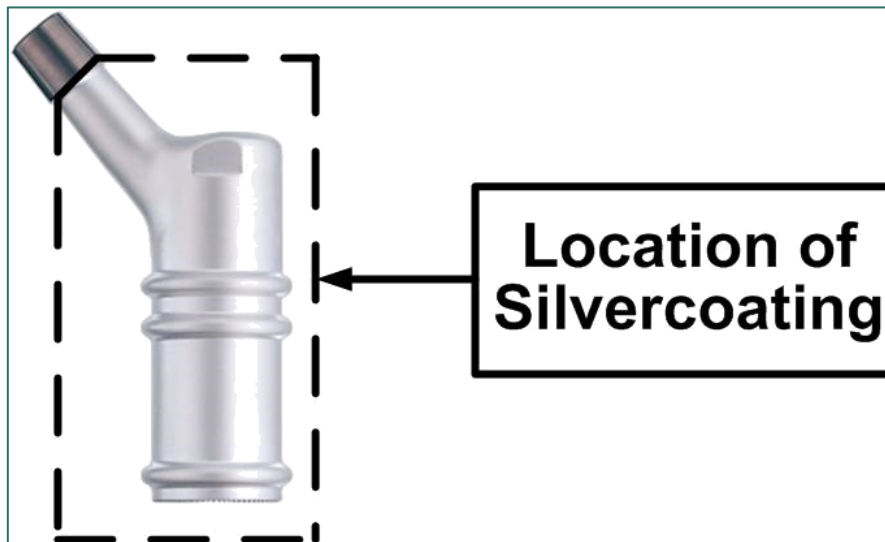

FIGURE 33. MUTARS® PROX. FEMUR – LOCATION OF SILVER COATING

TABLE 2. MUTARS® PROX. FEMUR – SURFACE AREA AND SILVER MASS

REF NUMBER	ITEM DESCRIPTION	SIZE	SURFACE AREA SILVER COATING (mm ²)	MASS SILVER [g]
5710020500S	MUTARS® proximal femur silver	50 mm	5344	1.12
5710020700S	MUTARS® proximal femur silver	70 mm	7003	1.47

MUTARS® prox. femur revision and Trochanter plate for MUTARS® proximal femur revision

The *MUTARS® prox. femur revision* has a sand blasted surface finish and incorporates a porous EPORE® structure on its cranio-lateral side. The structure is characterized by a rod thickness of 360 ±

50 µm and features a high affinity with trabecular bone tissue. It is available uncoated and with silver coating that is applied circumferentially. The *trochanter plate for MUTARS® proximal femur revision* has a sand blasted surface finish.

TABLE 3. EPORE® SPECIFICATIONS

PARAMETER	VALUE
MANUFACTURING PROCESS	ADDITIVE MANUFACTURING (ELECTRON BEAM MELTING (EBM))
POROSITY	61% ± 8%
SPECIFIC E-MODULE	3.1 GPa ± 0.6 GPa
ROD DIAMETER	360 µm ± 50 µm

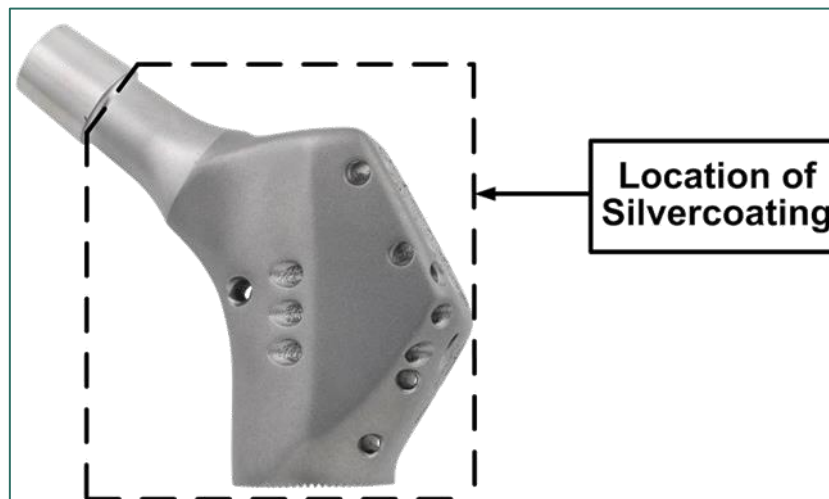

FIGURE 34. MUTARS® PROX. FEMUR REVISION – LOCATION OF SILVER COATING

TABLE 4. MUTARS® PROX. FEMUR REVISION – SURFACE AREA AND SILVER MASS

REF NUMBER	ITEM DESCRIPTION	SIZE	SURFACE AREA SILVER COATING (mm ²)	MASS SILVER [g]
5710030500S	MUTARS® prox. femur revision silver	50/127°	13396	2.81
5710030700S	MUTARS® prox. femur revision silver	70/127°	16016	3.36
5710040500S	MUTARS® prox. femur revision silver	50/135°	13328	2.80
5710040700S	MUTARS® prox. femur revision silver	70/135°	15943	3.35

The *MUTARS® extension piece* has a sand blasted surface finish. It is available uncoated and with silver coating that is applied circumferentially.

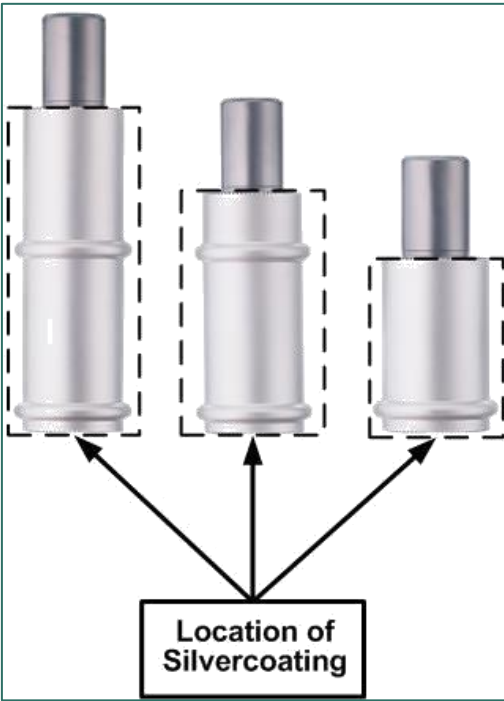

FIGURE 35. MUTARS® EXTENSION PIECE – LOCATION OF SILVER COATING

TABLE 5. MUTARS® EXTENSION PIECE – SURFACE AREA AND SILVER MASS

REF NUMBER	ITEM DESCRIPTION	SIZE	SURFACE AREA SILVER COATING (mm ²)	MASS SILVER [g]
57722503S	MUTARS® extension piece silver	30mm	2514	0.53
57722504S	MUTARS® extension piece silver	40mm	3300	0.69
57722506S	MUTARS® extension piece silver	60mm	5074	1.07
57722508S	MUTARS® extension piece silver	80mm	3345	0.70
57722510S	MUTARS® extension piece silver	100mm	8419	1.77

MUTARS® connecting part

The *MUTARS® connecting part* has a sand blasted surface finish. It is available uncoated and with silver coating that is applied circumferentially.

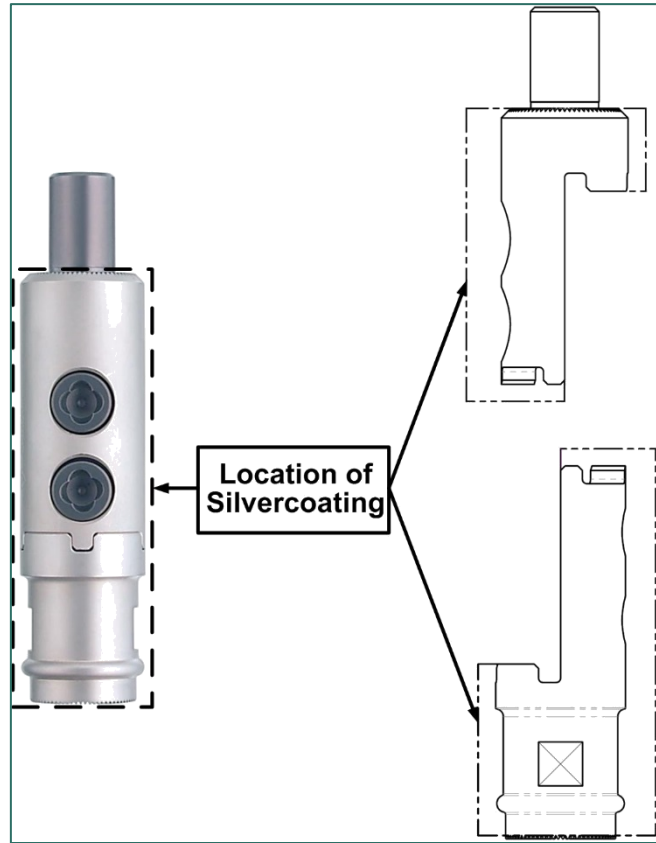

FIGURE 36. MUTARS® CONNECTING PART – LOCATION OF SILVER COATING

TABLE 6. MUTARS® CONNECTING PART – SURFACE AREA AND SILVER MASS

REF NUMBER	ITEM DESCRIPTION	SIZE	SURFACE AREA SILVER COATING (mm ²)	MASS SILVER [g]
57300100S	MUTARS® connecting part silver	100mm	8795	1.85

MUTARS® reducer

The *MUTARS® reducer* has a sand blasted surface finish. It is available uncoated and with silver coating that is applied circumferentially.

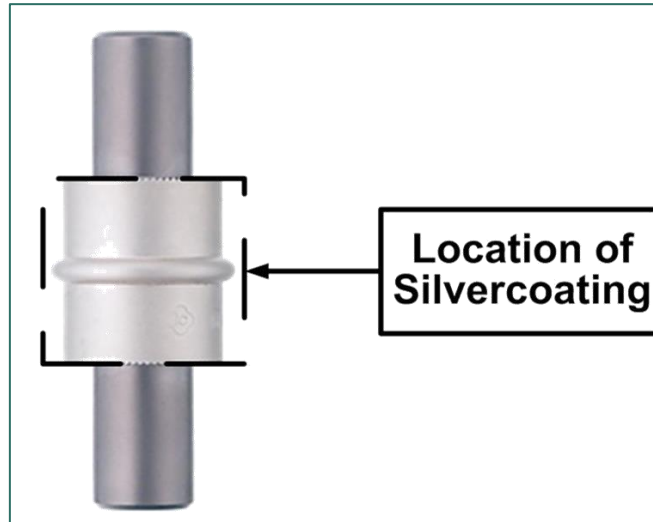

FIGURE 37. MUTARS® REDUCER - LOCATION OF SILVER COATING

TABLE 7. MUTARS® REDUCER – SURFACE AREA AND SILVER MASS

REF NUMBER	ITEM DESCRIPTION	SIZE	SURFACE AREA SILVER COATING (mm ²)	MASS SILVER [g]
57300220S	MUTARS® reducer silver	20 mm	1728	0.36
57300230S	MUTARS® reducer silver	30 mm	2505	0.53

Screws

MUTARS® screw, MUTARS® safety screw, MUTARS® screw for connecting part, and MUTARS® screw for RS coupling device have a sand blasted surface.

MUTARS® end piece

The *MUTARS® end piece* has a sand blasted surface finish. It is available uncoated and with silver coating applied to the cap.

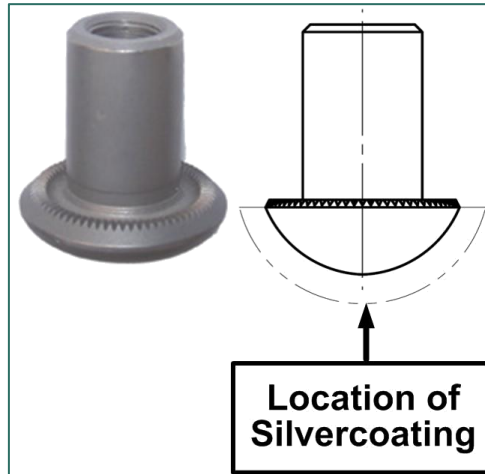

FIGURE 38. MUTARS® END PIECE – LOCATION OF SILVER COATING

TABLE 8. MUTARS® END PIECE – SURFACE AREA AND SILVER MASS

REF NUMBER	ITEM DESCRIPTION	SIZE	SURFACE AREA SILVER COATING (mm ²)	MASS SILVER [g]
58600001S	MUTARS® end piece silver	/	774	0.16

MUTARS® RS coupling device

The *MUTARS® RS coupling device* has a sand blasted surface finish. It is available uncoated and with silver coating that is applied circumferentially.



FIGURE 39. MUTARS® RS COUPLING DEVICE – LOCATION OF SILVER COATING

TABLE 9. MUTARS® RS COUPLING DEVICE – SURFACE AREA AND SILVER MASS

REF NUMBER	ITEM DESCRIPTION	SIZE	SURFACE AREA SILVER COATING (mm ²)	MASS SILVER [g]
57720030S	MUTARS® RS coupling device silver	30 mm	2507	0.53

MUTARS® intramed. connecting module for KRI

The *MUTARS® intramed. connecting module for KRI* has a rough corundum blasted surface. It is available uncoated and with silver coating that is applied circumferentially.

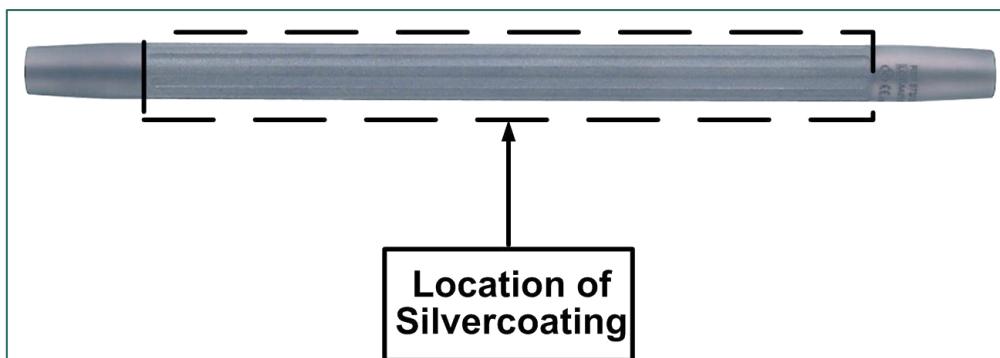

FIGURE 40. MUTARS® INTRAMED. CONNECTING MODULE FOR KRI – LOCATION OF SILVER COATING

TABLE 10. MUTARS® INTRAMED. CONNECTING MODULE FOR KRI – SURFACE AREA AND SILVER MASS

REF NUMBER	ITEM DESCRIPTION	SIZE	SURFACE AREA SILVER COATING (mm ²)	MASS SILVER [g]
57205100S	MUTARS® intramed.connecting module for KRI silver	15/100mm	4704	0.99
57205120S	MUTARS® intramed.connecting module for KRI silver	15/120mm	5712	1.20
57205140S	MUTARS® intramed.connecting module for KRI silver	15/140mm	6704	1.41
57205160S	MUTARS® intramed.connecting module for KRI silver	15/160mm	7697	1.62
57205180S	MUTARS® intramed.connecting module for KRI silver	15/180mm	8689	1.82
57205200S	MUTARS® intramed.connecting module for KRI silver	15/200mm	9681	2.03
57205220S	MUTARS® intramed.connecting module for KRI silver	15/220mm	10674	2.24
57205240S	MUTARS® intramed.connecting module for KRI silver	15/240mm	11666	2.45
57205260S	MUTARS® intramed.connecting module for KRI silver	15/260mm	12658	2.66
57205280S	MUTARS® intramed.connecting module for KRI silver	15/280mm	13650	2.87
57205300S	MUTARS® intramed.connecting module for KRI silver	15/300mm	14643	3.08
57205320S	MUTARS® intramed.connecting module for KRI silver	15/320mm	15635	3.28
57205340S	MUTARS® intramed.connecting module for KRI silver	15/340mm	16627	3.49
57205360S	MUTARS® intramed.connecting module for KRI silver	15/360mm	17620	3.70

MUTARS® intramed. connecting module for GenuX® MK femur

The *MUTARS® intramed. connecting module for GenuX® femur* and *MUTARS® intramed. connecting module for GenuX® MK femur* have a rough corundum blasted surface. They are available uncoated and with silver coating that is applied circumferentially.

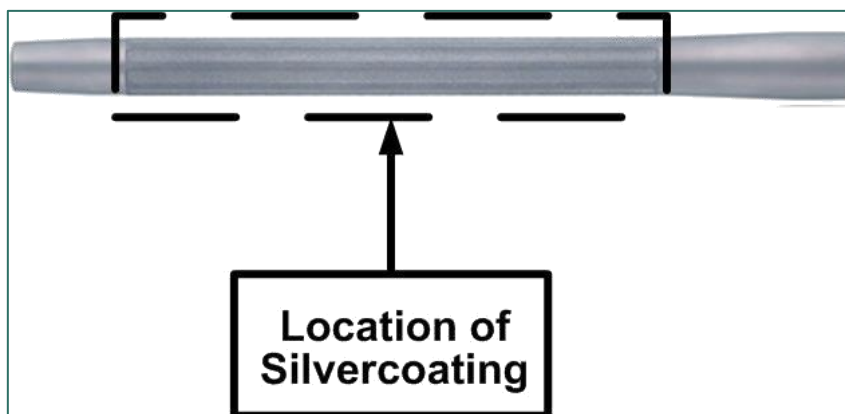

FIGURE 41. MUTARS® INTRAMED. CONNECTING MODULE FOR GENUX® MK FEMUR – LOCATION OF SILVER COATING

TABLE 11. MUTARS® INTRAMED. CONNECTING MODULE FOR GENUX® MK FEMUR – SURFACE AREA AND SILVER MASS

REF NUMBER	ITEM DESCRIPTION	SIZE	SURFACE AREA SILVER COATING (mm ²)	MASS SILVER [g]
57216100S	MUTARS® intramed. connecting module for GenuX® MK femur silver	Ø15/100 mm	-	-
57216120S	MUTARS® intramed. connecting module for GenuX® MK femur silver	Ø15/120 mm	2242	0.47
57216140S	MUTARS® intramed. connecting module for GenuX® MK femur silver	Ø15/140 mm	3234	0.68
57216160S	MUTARS® intramed. connecting module for GenuX® MK femur silver	Ø15/160 mm	4227	0.89
57216180S	MUTARS® intramed. connecting module for GenuX® MK femur silver	Ø15/180 mm	5219	1.10
57216200S	MUTARS® intramed. connecting module for GenuX® MK femur silver	Ø15/200 mm	6211	1.30
57216220S	MUTARS® intramed. connecting module for GenuX® MK femur silver	Ø15/220 mm	7204	1.51
57216240S	MUTARS® intramed. connecting module for GenuX® MK femur silver	Ø15/240 mm	8196	1.72
57216260S	MUTARS® intramed. connecting module for GenuX® MK femur silver	Ø15/260 mm	9188	1.93
57216280S	MUTARS® intramed. connecting module for GenuX® MK femur silver	Ø15/280 mm	10180	2.14
57216300S	MUTARS® intramed. connecting module for GenuX® MK femur silver	Ø15/300 mm	11173	2.35
57216320S	MUTARS® intramed. connecting module for GenuX® MK femur silver	Ø15/320 mm	12165	2.55
57216340S	MUTARS® intramed. connecting module for GenuX® MK femur silver	Ø15/340 mm	13157	2.76
57216360S	MUTARS® intramed. connecting module for GenuX® MK femur silver	Ø15/360 mm	14150	2.97
57216380S	MUTARS® intramed. connecting module for GenuX® MK femur silver	Ø15/380 mm	15142	3.18
57216400S	MUTARS® intramed. connecting module for GenuX® MK femur silver	Ø15/400 mm	16134	3.39
57216420S	MUTARS® intramed. connecting module for GenuX® MK femur silver	Ø15/420 mm	17126	3.60
57216440S	MUTARS® intramed. connecting module for GenuX® MK femur silver	Ø15/440 mm	18119	3.80

MUTARS® HMRS adapters

The *MUTARS® HMRS adapter female taper*, and *MUTARS® HMRS adapter male taper* are silver coated. The silver coating that is applied circumferentially.

13 Sizes and Dimensions

13.1 MUTARS® prox. femur

The *MUTARS® prox. femur* is available in two lengths of 50 mm and 70 mm to realize an individual bone replacement depending on each individual defect length. The CCD angle of the *MUTARS® proximal femur* is 140° with an offset of 35 mm.

The sizes and their respective dimensions are given in TABLE 12.

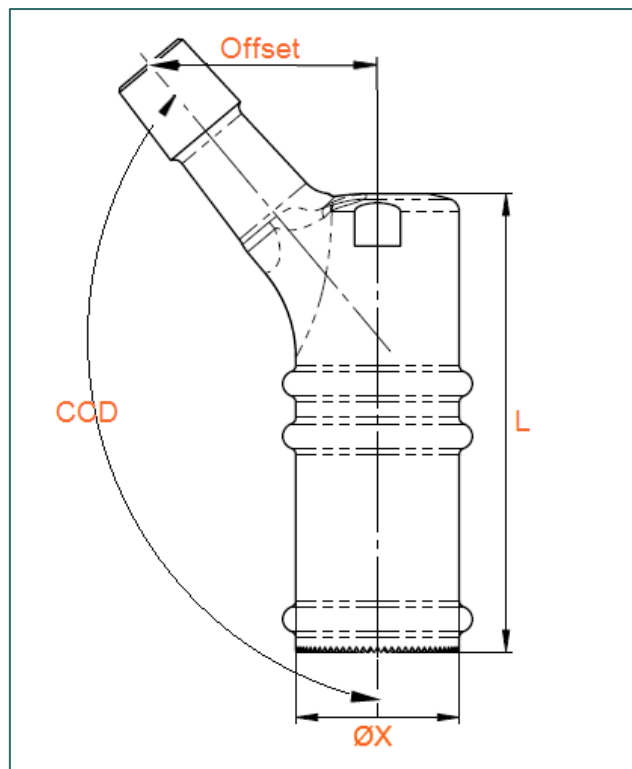

FIGURE 42. DIMENSIONS OF THE MUTARS® PROX. FEMUR

TABLE 12. SIZES AND DIMENSIONS OF THE MUTARS® PROX. FEMUR

SIZE	LENGTH (L) [mm]	Ø X [mm]	CCD	OFFSET [mm]
50mm	50	25	140°	35
70mm	70	25	140°	35

13.2 MUTARS® prox. femur revision and trochanter plates for MUTARS® proximal femur revision

The *MUTARS® prox. femur revision* is available with two (2) stem – neck angles (CCD angle) of 127° and 135° offering two offsets, which allows for anatomically adjustments without affecting the leg length, and in two (2) nominal lengths of 50 mm and 70 mm to realize an individual bone replacement depending on each individual defect length. The sizes and their respective dimensions are given in TABLE 13.

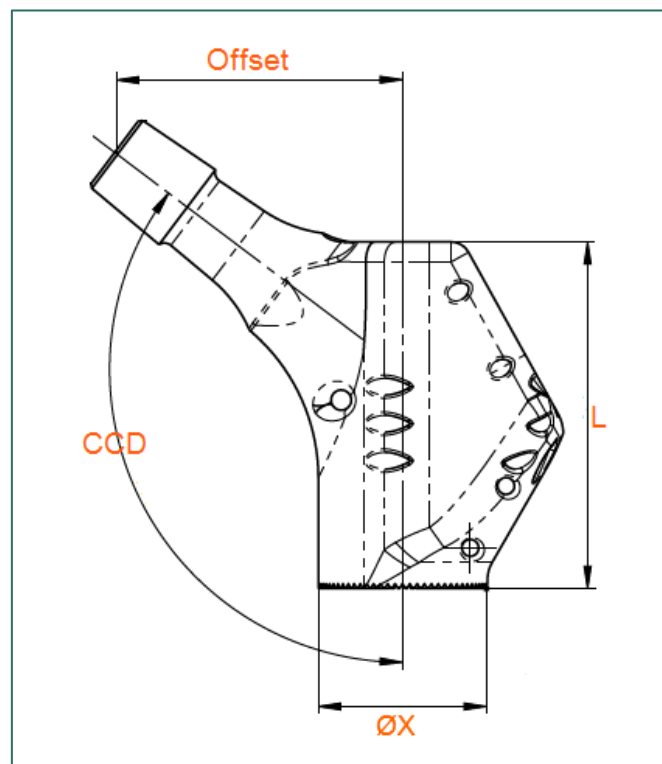

FIGURE 43. DIMENSIONS OF THE MUTARS® PROX. FEMUR REVISION

TABLE 13. SIZES AND DIMENSIONS OF THE MUTARS® PROX. FEMUR REVISION

SIZE	LENGTH (L) [mm]	Ø X [mm]	CCD	OFFSET [mm]
50/127°	51.5	25	127°	39.3
70/127°	71.5	25	127°	39.3
50/135°	51.5	25	135°	35.2
70/135°	71.5	25	135°	35.2

The dimensions of the *trochanter plates for MUTARS® proximal femur revision* are shown in FIGURE 44 and FIGURE 45.

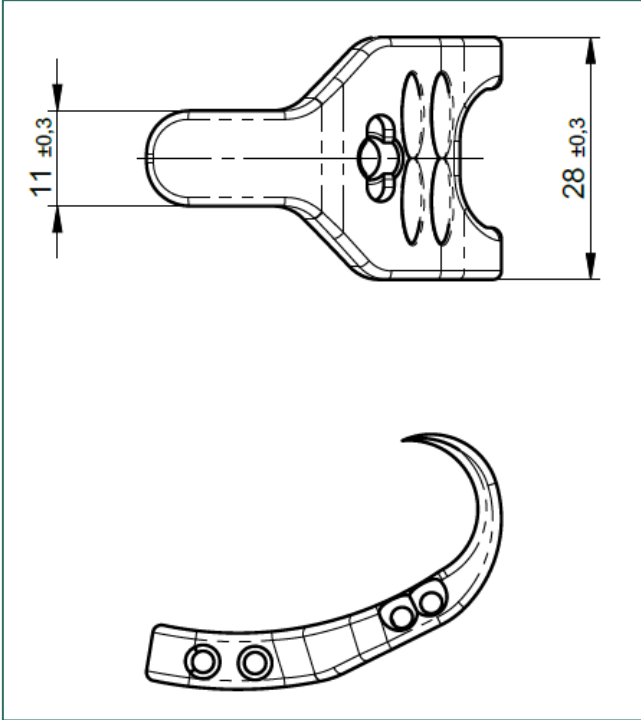

FIGURE 44. DIMENSIONS OF THE TROCHANTER PLATE FOR MUTARS® PROX. FEMUR REVISION SHORT

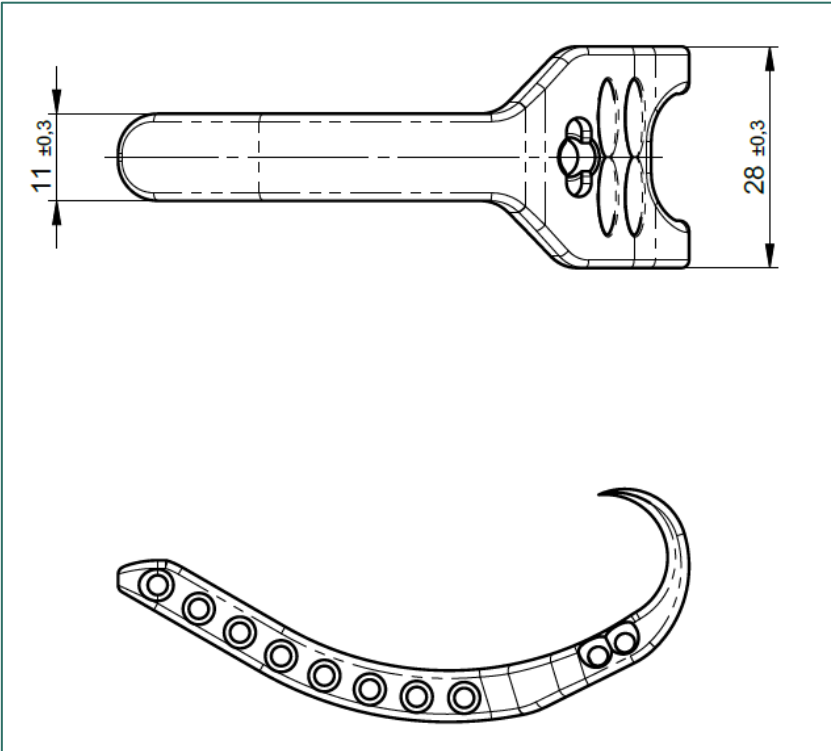

FIGURE 45. DIMENSIONS OF THE TROCHANTER PLATE FOR MUTARS® PROX. FEMUR REVISION LONG

13.3 MUTARS® extension piece

The *MUTARS® extension piece* is available in lengths of 40, 60, 80 and 100 mm and additionally 30mm if silver-coated. The sizes and their respective dimensions are given in TABLE 14. The *MUTARS® PT extension piece* features a shorter length of the cylindrical fit (18 mm instead of 23.5mm).

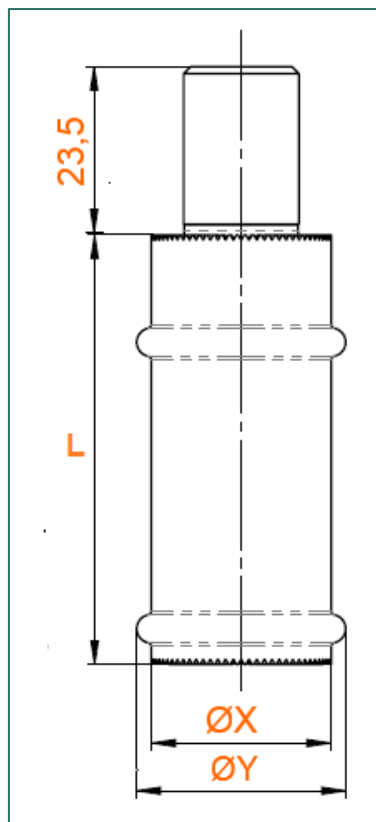

FIGURE 46. DIMENSIONS OF THE MUTARS® EXTENSION PIECE

TABLE 14. SIZES AND DIMENSIONS OF THE MUTARS® EXTENSION PIECE

SIZE	LENGTH (L) [mm]	Ø X [mm]	Ø Y [mm]
30mm	30	25	29
40mm	40	25	29
60mm	60	25	29
80mm	80	25	29
100mm	100	25	29

13.4 MUTARS® connecting part and MUTARS® screw for connecting part

The *MUTARS® connecting part* is available in a length of 100 mm and diameter of 29.5 mm.

The *MUTARS® screw for connecting part* has a length of 26 mm. The diameter of the thread is 10 mm and of the head 14 mm. The length of the head is 8.5 mm. The pitch of the thread is 1 mm (M10x1) (cf. FIGURE 48).

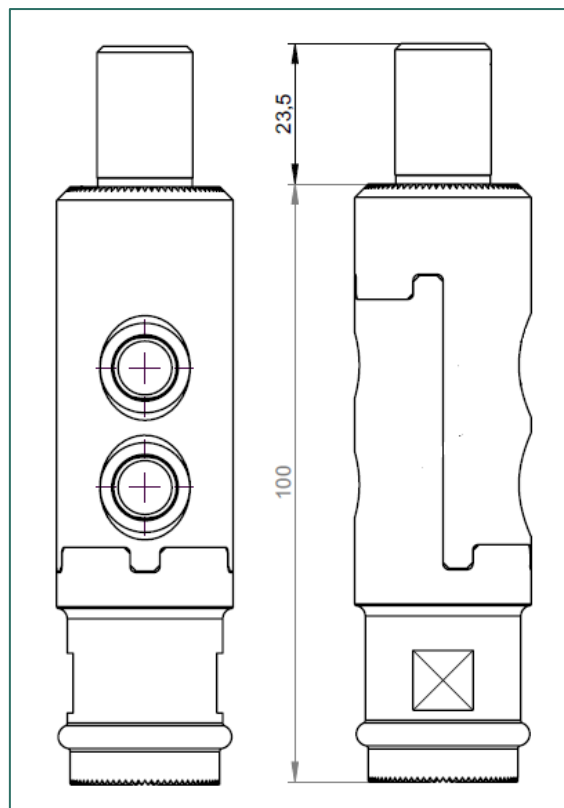

FIGURE 47. DIMENSIONS OF THE MUTARS® CONNECTING PART

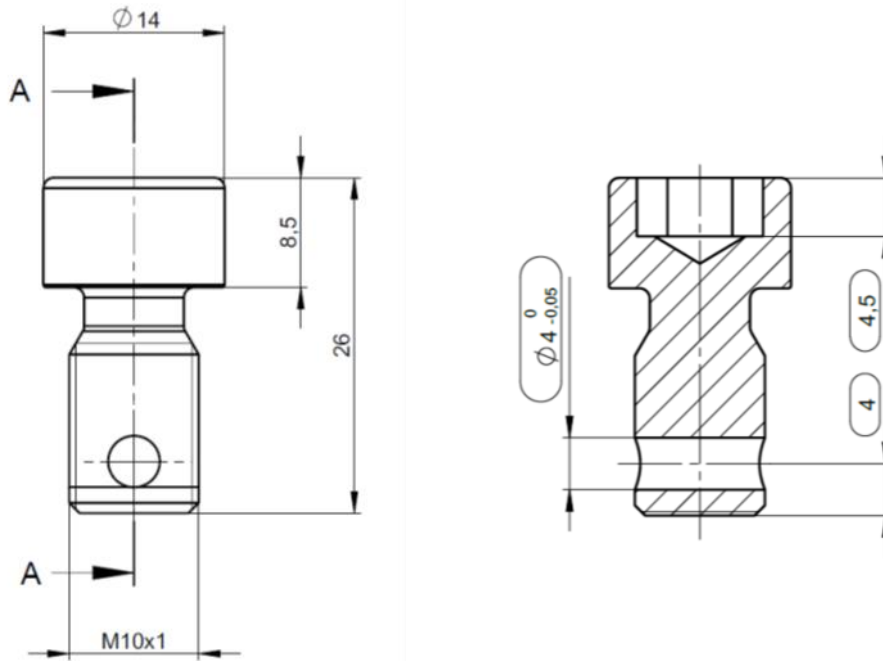

FIGURE 48. DIMENSIONS OF THE MUTARS® SCREW FOR CONNECTING PART

13.5 MUTARS® reducer

The *MUTARS® reducer* is available in lengths of 20 mm and 30 mm. The sizes and their respective dimensions are given in TABLE 15. The *MUTARS® PT reducer* features a shorter length of the cylindrical fit (18 mm instead of 23.5mm).

TABLE 15. SIZES AND DIMENSIONS OF THE MUTARS® REDUCER

SIZE	LENGTH (L) [mm]	H [mm]
20mm	20	67
30mm	30	77

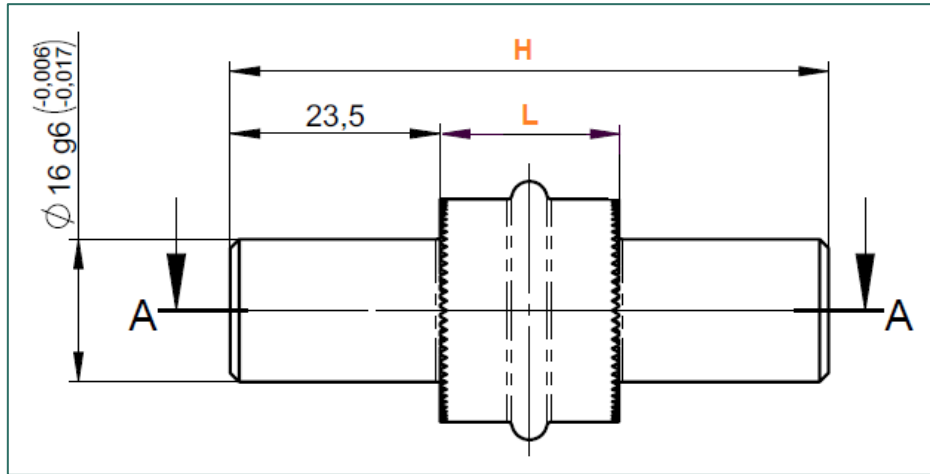

FIGURE 49. DIMENSIONS OF THE MUTARS® REDUCER

13.6 MUTARS® screw and MUTARS® safety screw

Due to the various length adjustments within the MUTARS® Proximal Femur Replacement System, the *MUTARS® screw* is available in different lengths ranging from 25mm to 245mm. The diameter of the thread is 10 mm and of the head 14 mm. The length of the head is 8.5 mm and the length of the thread itself is 20 mm in all sizes. The pitch of the thread is 1 mm (M10x1) (cf. FIGURE 50).

The sizes and their respective lengths are given in TABLE 16.

TABLE 16. SIZES AND LENGTHS OF THE MUTARS® SCREW

SIZE	LENGTH (L) [mm]
M10x25mm	25
M10x45mm	45
M10x55mm	55
M10x65mm	65
M10x75mm	75
M10x85mm	85
M10x95mm	95
M10x105mm	105
M10x115mm	115
M10x125mm	125
M10x135mm	135
M10x145mm	145

SIZE	LENGTH (L) [mm]
M10x165mm	165
M10x185mm	185
M10x205mm	205
M10x225mm	225
M10x245mm	245

The *MUTARS®* safety screw (cf. FIGURE 51) has a diameter of 16 mm and an overall length of 7.5 mm. The pitch of the thread is 1.5 mm (M16x1.5 mm).

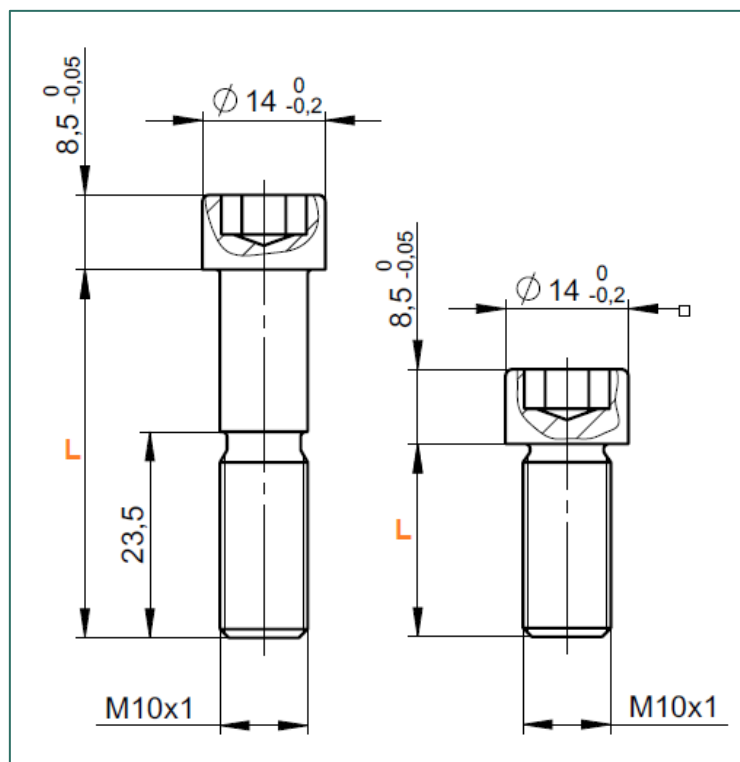

FIGURE 50. DIMENSIONS OF THE MUTARS® SCREW; THE SCREW OF THE SAMLLEST SIZE M10X25MM (AT THE RIGHT PICTURE)

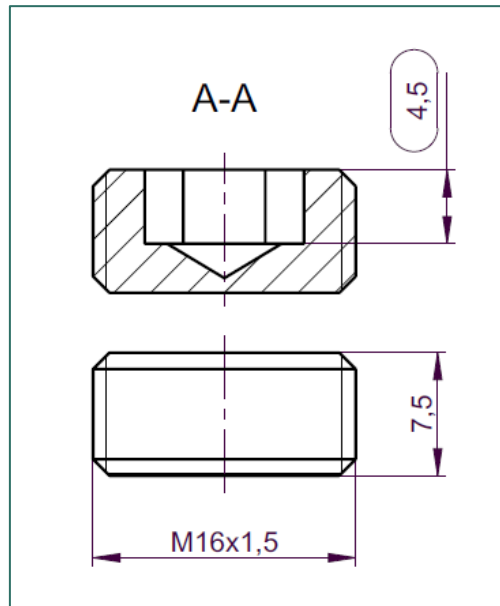

FIGURE 51. DIMENSIONS OF THE MUTARS® SAFETY SCREW

13.7 MUTARS® end piece

The *MUTARS® end piece* has a diameter of 26 mm and length of 33.5 mm (cf. FIGURE 52).

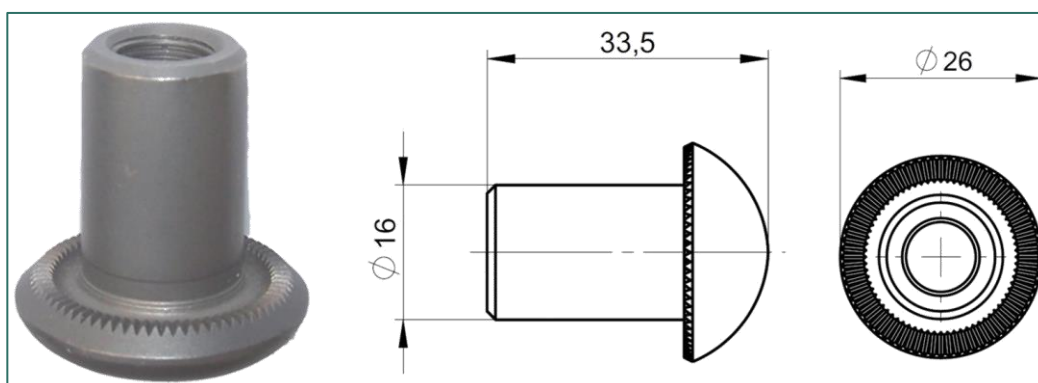

FIGURE 52. DIMENSIONS OF THE MUTARS® END PIECE

13.8 MUTARS® RS coupling device and MUTARS® screw for RS coupling device

The *MUTARS® RS coupling device* has a diameter of 28 mm and length of 30 mm. The dimensions are shown in FIGURE 53.

The *MUTARS® screw for RS coupling device* is available in different lengths ranging from 60 to 140 mm. The diameter of the thread is 8 mm and of the head 14 mm. The length of the head is 8.5 mm and the length of the thread itself is 15 mm in all sizes. The pitch of the thread is 1 mm (M8x1) (cf.FIGURE 54).

The screw sizes and their respective lengths are given in TABLE 17.

TABLE 17. SIZES AND LENGTHS OF THE MUTARS® SCREW FOR RS COUPLING DEVICE

SIZE	LENGTH (L) [mm]
M8x60mm	60
M8x80mm	80
M8x100mm	100
M8x120mm	120
M8x140mm	140

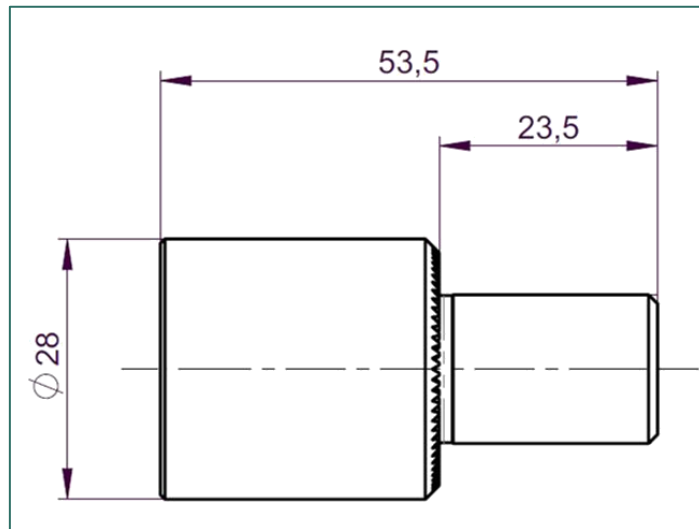

FIGURE 53. DIMENSIONS OF THE MUTARS® RS COUPLING DEVICE

TABLE 18. SIZES AND LENGTHS OF THE MUTARS® INTRAMED. CONNECTING MODULE FOR KRI

SIZE	LENGTH (L) [mm]	LENGTH (A) [mm]	Ø at B-B [mm]
15/100mm	100	136	15
15/120mm	120	156	15
15/140mm	140	176	15
15/160mm	160	196	15
15/180mm	180	216	15
15/200mm	200	236	15
15/220mm	220	256	15
15/240mm	240	276	15
15/260mm	260	296	15
15/280mm	280	316	15
15/300mm	300	336	15
15/320mm	320	356	15
15/340mm	340	376	15
15/360mm	360	396	15

13.10 MUTARS® intramed. connecting module for GenuX® MK femur and the MUTARS® intramed. connecting module for GenuX® femur

The *MUTARS® intramed. connecting module for GenuX® MK femur* is available in length from 66.29 mm to 386.29 mm in 20 mm increments to offer an individual reconstruction of the leg length as well as an adjustment in case of an existing leg length discrepancy. It is only available in one diameter of 15 mm (cf. FIGURE 56). The sizes and their respective lengths are given in TABLE 19.

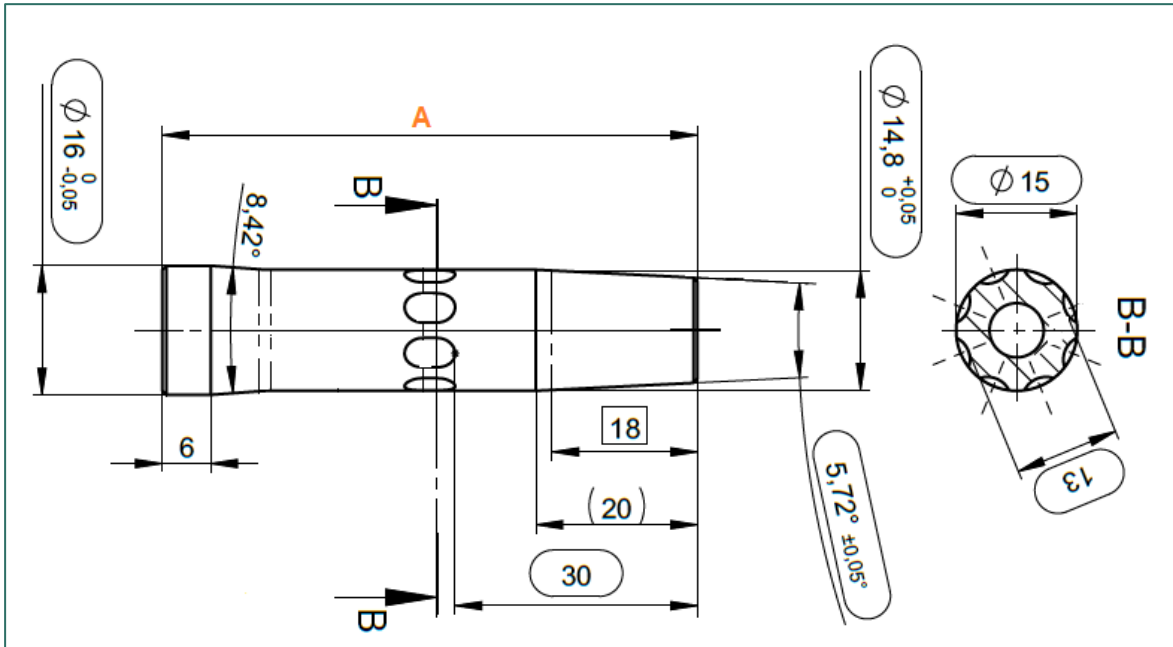

FIGURE 56. DIMENSIONS OF THE MUTARS® INTRAMED. CONNECTING MODULE FOR GENUX® MK FEMUR

TABLE 19. SIZES AND LENGTHS OF THE MUTARS® INTRAMED. CONNECTING MODULE FOR GENUX® MK FEMUR

SIZE	LENGTH (A) [mm]	Ø at B-B [mm]
15/120mm	66.29	15
15/140mm	86.29	15
15/160mm	106.29	15
15/180mm	126.29	15
15/200mm	146.29	15
15/220mm	166.29	15
15/240mm	186.29	15
15/260mm	206.29	15
15/280mm	226.29	15
15/300mm	246.29	15
15/320mm	266.29	15
15/340mm	286.29	15
15/360mm	306.29	15
15/380mm	326.29	15
15/400mm	346.29	15
15/420mm	366.29	15
15/440mm	386.29	15

The *MUTARS® intramed. connecting module for GenuX® femur* is available in length from 158 mm to 418 mm in 20 mm increments to offer an individual reconstruction of the leg length as well as an adjustment in case of an existing leg length discrepancy. It is only available in one diameter of 15 mm.

The sizes and their respective lengths are given in TABLE 20.

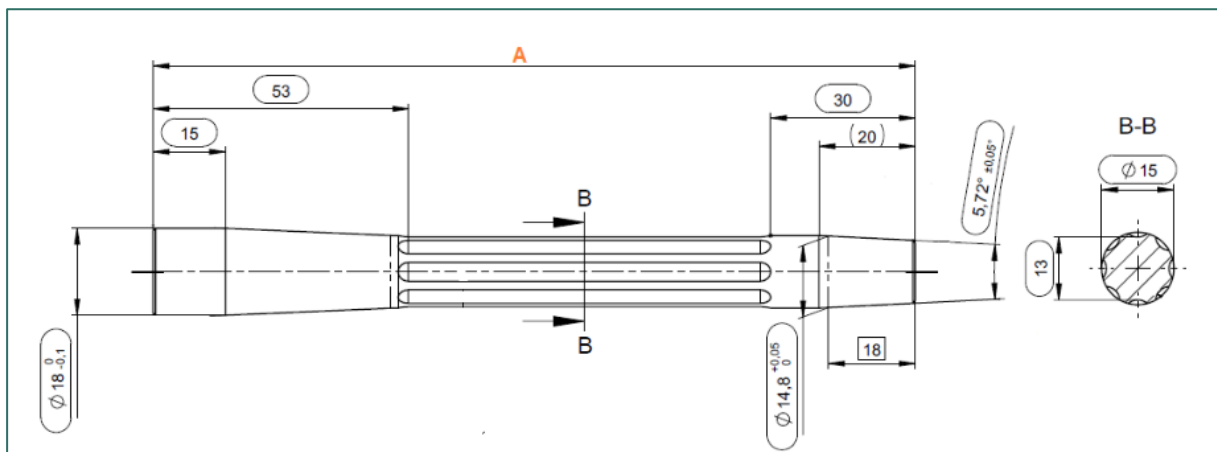

FIGURE 57. MUTARS® INTRAMED. CONNECTING MODULE FOR GENUX® FEMUR

TABLE 20. SIZES AND LENGTHS OF THE MUTARS® INTRAMED. CONNECTING MODULE FOR GENUX® FEMUR

SIZE	LENGTH (A) [mm]	Ø at B-B [mm]
15/180mm	158	15
15/200mm	178	15
15/220mm	198	15
15/240mm	218	15
15/260mm	238	15
15/280mm	258	15
15/300mm	278	15
15/320mm	298	15
15/340mm	318	15
15/360mm	338	15
15/380mm	358	15
15/400mm	378	15
15/420mm	398	15
15/440mm	418	15

13.11 MUTARS® HMRS adapter

The dimensions are shown in FIGURE 58 and FIGURE 59. The sizes and their respective lengths are given in TABLE 21 and TABLE 22.

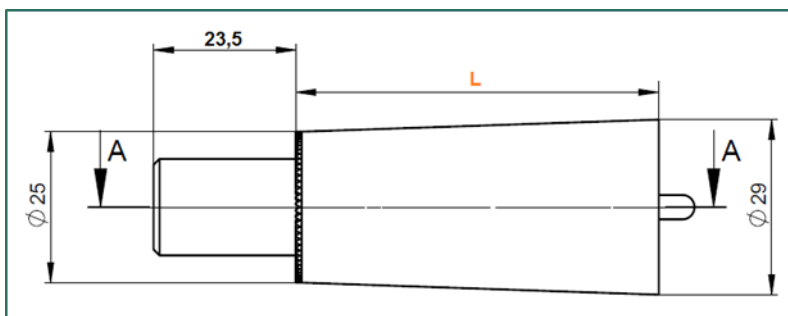

FIGURE 58. DIMENSIONS OF THE MUTARS® HMRS ADAPTER FEMALE TAPER

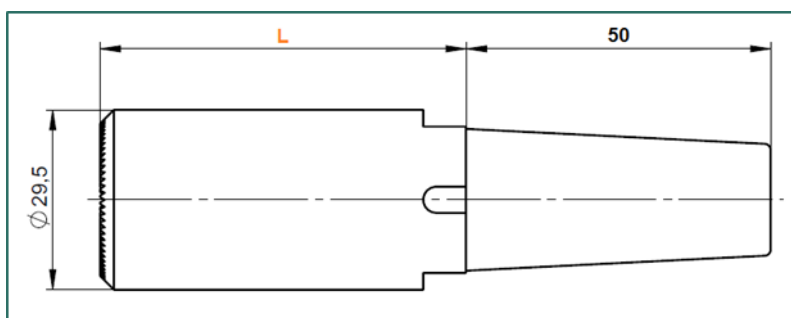

FIGURE 59. DIMENSIONS OF THE MUTARS® HMRS ADAPTER MALE TAPER

TABLE 21. SIZES AND LENGTHS OF THE MUTARS® HMRS ADAPTER FEMALE TAPER

SIZE	LENGTH (L) [mm]
60mm	60
70mm	70

TABLE 22. SIZES AND LENGTHS OF THE MUTARS® HMRS ADAPTER MALE TAPER

SIZE	LENGTH (L) [mm]
40mm	40
60mm	60

14 Compatibility

The detailed component compatibility is given in the ANNEX I to the Instructions for Use for the MUTARS® Tumor and Revision System.

- ⇒ See „09300095 MUTARS Tumor- und Revisionssystem Kombinationsmöglichkeiten_Anhang I” (ANNEX I - IFU – MUTARS® COMBINABILITY) in the folder “05 Kennzeichnung” subfolder „Gebrauchsinformation“
-

15 Warnings

Information about warnings for the MUTARS® Proximal Femur System can be found in the Instruction for Use.

- ⇒ See Doc. „Instruction for Use “09300013 MUTARS Tumor- und Revisionssystem” in the folder “05 Kennzeichnung” subfolder „Gebrauchsinformation“
-

16 Product List (Identification of the Products)

For identification of the products by their respective number (Basic UDI-DI, reference number (REF)), please refer to the product list.

- ⇒ See Doc. “Fbl_732-1-0-14_Produktliste_MUTARS Prox. Femur System” (product list for MUTARS® Proximal Femur System) in the folder “02 Produktliste”
-

17 Reference to Previous Generations and Similar Devices

Information about previous generations of the products can be found in the product history.

- ⇒ See Doc. “Fbl_423-1-2-2_Produkthistorie Technische Dokumentation” (Product history Technical Documentation) in the folder “16 Produkthistorie”

Similar device available on the markets is the GMRS™ from the company Stryker/Howmedica.

LISTS

18 LIST OF FIGURES

FIGURE 1. MUTARS® CYLINDRICAL FIT AND SERRATION CONNECTION..... 4

FIGURE 2. MUTARS® PROX. FEMUR WITH FEMORAL STEM CEMENTLESS AND BIPOLAR HEAD. ON THE LEFT WITH MUTARS® EXTENTION PIECE 5

FIGURE 3. MUTARS® PROXIMAL FEMUR WITH MUTARS® STEM MODULAR CEMENTED AND MUTARS® EPORE® HA COLLAR 5

FIGURE 4. MUTARS® PROX. FEMUR WITH MUTARS® FEMORAL STEM. ON THE LEFT WITH MUTARS® CONNECTING PART 6

FIGURE 5. MUTARS® PROX. FEMUR WITH MUTARS® RS STEM AND MUTARS® RS COUPLING DEVICE. ON THE LEFT WITH MUTARS® CONNECTING PART. 7

FIGURE 6. MUTARS® PROX. FEMUR INCL. SAFETY SCREW 11

FIGURE 7. 12/14 MORSE-TYPE TAPER TRUNNION AND THREADED HOLE FOR THE SAFETY SCREW 11

FIGURE 8. MUTARS® PROX. FEMUR INCL. SAFETY 11

FIGURE 9. FEMALE CYLINDRICAL FIT AND SERRATION CONNECTION 11

FIGURE 10. MUTARS® PROX. FEMUR REVISION WITH 12

FIGURE 11. MUTARS® PROX. FEMUR REVISION..... 12

FIGURE 12. MUTARS® PROX. FEMUR REVISION WITH TROCHANTERIC BONE 13

FIGURE 13. TROCHANTER PLATE FOR MUTARS® PROXIMAL FEMUR REVISION LONG..... 14

FIGURE 14. TROCHANTER PLATE FOR MUTARS® PROXIMAL FEMUR REVISION SHORT 14

FIGURE 15. MUTARS® EXTENSION PIECES 15

FIGURE 16. MALE CYLINDRICAL FIT AND SERRATION CONNECTION (LEFT PICTURE); FEMALE CYLINDRICAL FIT AND SERRATION CONNECTION (RIGHT PICTURE)..... 15

FIGURE 17. MUTARS® CONNECTING PART 16

FIGURE 18. MUTARS® SCREW FOR CONNECTING PART 17

FIGURE 19. MUTARS® REDUCER 17

FIGURE 20. MUTARS® REDUCER 18

FIGURE 21. MUTARS® TOTAL FEMUR MK 19

FIGURE 22. MUTARS® SCREW (LEFT PICTURE); MUTARS® SAFETY SCREW (RIGHT PICTURE) 20

FIGURE 23. MUTARS® END PIECE..... 21

FIGURE 24. MUTARS® RS COUPLING DEVICE..... 21

FIGURE 25. MUTARS® SCREW FOR RS COUPLING DEVICE FOR RS COUPLING DEVICE 22

FIGURE 26. MUTARS® INTRAMED. (INTRAMEDULLARY) CONNECTING MODULE FOR KRI 22

FIGURE 27. MUTARS® INTRAMED. CONNECTING MODULE FOR GENUX® MK FEMUR..... 23

FIGURE 28. MUTARS® INTRAMED. CONNECTING MODULE FOR GENUX® FEMUR	23
FIGURE 29. MUTARS® INTRAMED. CONNECTING MODULE FOR GENUX® FEMUR	24
FIGURE 30. MUTARS® PROX. FEMUR WITH MUTARS® RS COUPLIG DEVICE, MUTARS® INTRAMED. CONNECTING MODULE FOR GENUX® MK FEMUR AND MUTARS® GENUX® MK. 24	
FIGURE 31. MUTARS® HMRS ADAPTER FEMALE TAPER.....	25
FIGURE 32. MUTARS® HMRS ADAPTER MALE TAPER	25
FIGURE 33. MUTARS® PROX. FEMUR – LOCATION OF SILVER COATING	27
FIGURE 34. MUTARS® PROX. FEMUR REVISION – LOCATION OF SILVER COATING.....	28
FIGURE 35. MUTARS® EXTENSION PIECE – LOCATION OF SILVER COATING	29
FIGURE 36. MUTARS® CONNECTING PART – LOCATION OF SILVER COATING	30
FIGURE 37. MUTARS® REDUCER - LOCATION OF SILVER COATING	31
FIGURE 38. MUTARS® END PIECE – LOCATION OF SILVER COATING.....	32
FIGURE 39. MUTARS® RS COUPLING DEVICE – LOCATION OF SILVER COATING.....	33
FIGURE 40. MUTARS® INTRAMED. CONNECTING MODULE FOR KRI – LOCATION OF SILVER COATING	33
FIGURE 41. MUTARS® INTRAMED. CONNECTING MODULE FOR GENUX® MK FEMUR – LOCATION OF SILVER COATING.....	34
FIGURE 42. DIMENSIONS OF THE MUTARS® PROX. FEMUR.....	36
FIGURE 43. DIMENSIONS OF THE MUTARS® PROX. FEMUR REVISION	37
FIGURE 44. DIMENSIONS OF THE TROCHANTER PLATE FOR MUTARS® PROX. FEMUR REVISION SHORT	38
FIGURE 45. DIMENSIONS OF THE TROCHANTER PLATE FOR MUTARS® PROX. FEMUR REVISION LONG	38
FIGURE 46. DIMENSIONS OF THE MUTARS® EXTENSION PIECE	39
FIGURE 47. DIMENSIONS OF THE MUTARS® CONNECTING PART.....	40
FIGURE 48. DIMENSIONS OF THE MUTARS® SCREW FOR CONNECTING PART.....	41
FIGURE 49. DIMENSIONS OF THE MUTARS® REDUCER	42
FIGURE 50. DIMENSIONS OF THE MUTARS® SCREW; THE SCREW OF THE SAMLLEST SIZE M10X25MM (AT THE RIGHT PICTURE).....	43
FIGURE 51. DIMENSIONS OF THE MUTARS® SAFETY SCREW	44
FIGURE 52. DIMENSIONS OF THE MUTARS® END PIECE	44
FIGURE 53. DIMENSIONS OF THE MUTARS® RS COUPLING DEVICE	45
FIGURE 54. DIMENSIONS OF THE MUTARS® SCREW FOR RS COUPLING DEVICE	46
FIGURE 55. DIMENSIONS OF MUTARS® INTRAMED. CONNECTING MODULE FOR KRI.....	46
FIGURE 56. DIMENSIONS OF THE MUTARS® INTRAMED. CONNECTING MODULE FOR GENUX® MK FEMUR	48
FIGURE 57. MUTARS® INTRAMED. CONNECTING MODULE FOR GENUX® FEMUR	49

FIGURE 58. DIMENSIONS OF THE MUTARS® HMRS ADAPTER FEMALE TAPER 50
 FIGURE 59. DIMENSIONS OF THE MUTARS® HMRS ADAPTER MALE TAPER 50

19 LIST OF TABLES

TABLE 1: COATING SPECIFICATIONS FOR SILVER 26
 TABLE 2. MUTARS® PROX. FEMUR – SURFACE AREA AND SILVER MASS 27
 TABLE 3. EPORE® SPECIFICATIONS 28
 TABLE 4. MUTARS® PROX. FEMUR REVISION – SURFACE AREA AND SILVER MASS 28
 TABLE 5. MUTARS® EXTENSION PIECE – SURFACE AREA AND SILVER MASS 29
 TABLE 6. MUTARS® CONNECTING PART – SURFACE AREA AND SILVER MASS 30
 TABLE 7. MUTARS® REDUCER – SURFACE AREA AND SILVER MASS 31
 TABLE 8. MUTARS® END PIECE – SURFACE AREA AND SILVER MASS 32
 TABLE 9. MUTARS® RS COUPLING DEVICE – SURFACE AREA AND SILVER MASS 33
 TABLE 10. MUTARS® INTRAMED. CONNECTING MODULE FOR KRI – SURFACE AREA AND SILVER MASS 34
 TABLE 11. MUTARS® INTRAMED. CONNECTING MODULE FOR GENUX® MK FEMUR – SURFACE AREA AND SILVER MASS 35
 TABLE 12. SIZES AND DIMENSIONS OF THE MUTARS® PROX. FEMUR 36
 TABLE 13. SIZES AND DIMENSIONS OF THE MUTARS® PROX. FEMUR REVISION 37
 TABLE 14. SIZES AND DIMENSIONS OF THE MUTARS® EXTENSION PIECE 39
 TABLE 15. SIZES AND DIMENSIONS OF THE MUTARS® REDUCER 41
 TABLE 16. SIZES AND LENGTHS OF THE MUTARS® SCREW 42
 TABLE 17. SIZES AND LENGTHS OF THE MUTARS® SCREW FOR RS COUPLING DEVICE 45
 TABLE 18. SIZES AND LENGTHS OF THE MUTARS® INTRAMED. CONNECTING MODULE FOR KRI 47
 TABLE 19. SIZES AND LENGTHS OF THE MUTARS® INTRAMED. CONNECTING MODULE FOR GENUX® MK FEMUR 48
 TABLE 20. SIZES AND LENGTHS OF THE MUTARS® INTRAMED. CONNECTING MODULE FOR GENUX® FEMUR 49
 TABLE 21. SIZES AND LENGTHS OF THE MUTARS® HMRS ADAPTER FEMALE TAPER 50
 TABLE 22. SIZES AND LENGTHS OF THE MUTARS® HMRS ADAPTER MALE TAPER 50
 TABLE 22: LIST OF ABBREVIATIONS 55



20 LIST OF ABBREVIATIONS

TABLE 23: LIST OF ABBREVIATIONS

ABBREVIATION	ABBREVIATED TERM
CCD	caput-collum-diaphyseal angle
Ha	Hydroxyapatite
MDR	Medical Device Regulation
L	Length
TiN	Titanium Nitride
∅	Diameter



2 DOCUMENT REVISION HISTORY

DATE	REVISION	CHANGES	AUTHOR	COMMENTS
21.10.2021	0	Creation	A. Kerber	---