

MGB 1100 SL ROUND LID DIN VERSION
WITH TRUNNIONS

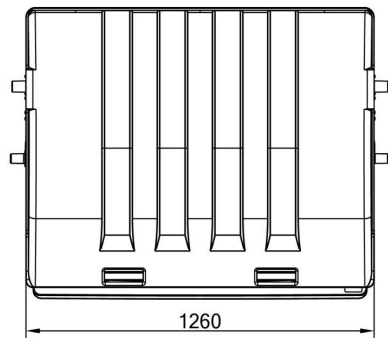
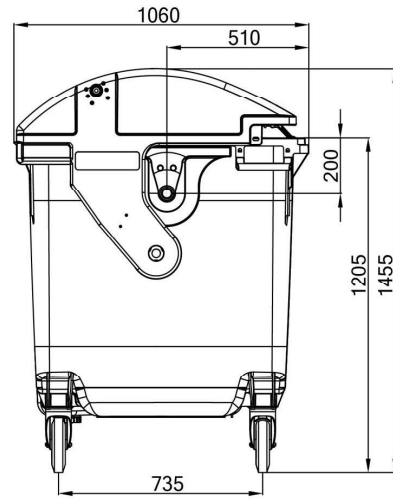
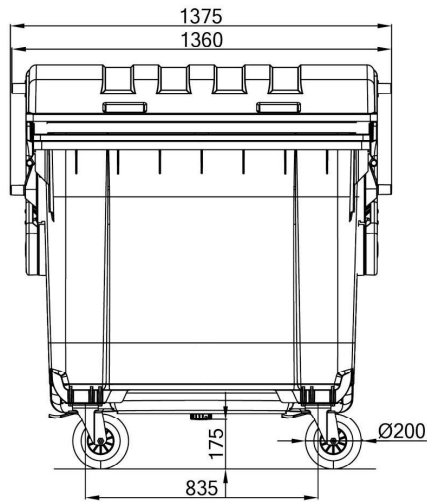

TECHNICAL DATA

Volume (L):	1,100.00
Curb weight approx. (kg):	60.00
Permissible total weight max. (kg):	510.00
Material:	HDPE, UV-stabilized
Wheels:	4 rubber wheels Ø 200mm 2 with wheel stop
Trunnions:	with steel reinforcement tubes
Lid / Container:	2 lid bearings, 2 side handles; Ø 25 mm (replaceable)
Certification:	EN 840, RAL GZ 951/1

OPTIONS

- Locking versions
- Lid apertures
- Hood apertures
- Lid variants
- Markings / Identification
- Alternative swivel castors
- Braking systems
- Lifting systems
- Special features / Accessories

The products do not contain any substances on the SVHC list of the European Chemicals Agency (ECHA).