

Annex 2 & 4

MANUFACTURER'S AUTHORIZATION

Date: 06.12.2022

Tender Reference:

**Construcția apeductului magistral Sărata-Răzeși – Voinescu – Mingir din r-nul Hîncești
(REPETAT)”**

MTender ID: **ocds-b3wdp1-MD-1669013317453**

To: **AGENȚIA DE DEZVOLTARE REGIONALA CENTRU**

We, **CMO VALVES LTD**, based in Guipuzcoa-Spain, Barrio Amategi 142, 20400 Tolosa, legally represented by Cristian Arrabal as Technical Manager having production facilities in Guipuzcoa-Spain, Barrio Amategi 142, 20400 Tolosa, as manufacturer of:

- GATE VALVES,
- AUTOMATIC VALVES,
- BUTTERFLY VALVES,
- CHECK VALVES,



VÁLVULAS DE GUILLOTINA
COMPUERTAS PARA AGUAS
DAMPERS PARA GASES

KNIFE GATE VALVES
PENSTOCKS
DAMPERS FOR GASES

- AIR VALVE (TRIPLE FUNCTION)

We authorize consortium of companies **VEGAN-COM S.R.L. - PROSPERUS-CONS S.R.L** with the headquarters in Republic of Moldova, raion Straseni, or.Vorniceni str.E.Coca nr.6 and Republic of Moldova, mun.Chisinau, s.Hulboaca, str.Alba Iulia nr.5, to submit a complete offer which purpose is the supply of the above-mentioned products.

CMO VALVES TECHNOLOGY S.L. is a valve manufacturer with more than 40 years of experience, manufacturing and selling to all the countries in the world, working with the most important building companies and growing every year.

We also agree that consortium of companies **VEGAN-COM S.R.L. - PROSPERUS-CONS S.R.L** shall submit to this tender the technical documentation, the sanitary certifications and approvals, the specific technical approvals and approvals to put into operation the products mentioned above.

Signed by: Mr. Cristian Arrabal

as: Technical Manager

Signature: & Stamp:

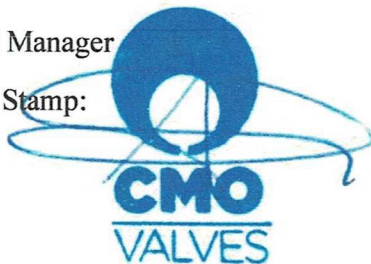

Amategi Aldea, 142
20400 Tolosa
Guipuzcoa (Spain)
(+34) 943 67 33 99
cmo@cmovalves.com
www.cmovalves.com

VÁLVULAS Y COMPUERTAS
VALVES & PENSTOCKS

www.cmovalves.com



CMO VALVES
manufacturing the valve you need



11A SERIES



FABRICATION RANGE *RESILIENT SEAT GATE VALVE*

UTILIZATION:

- Resilient seat gate valve for pumping, irrigation, drinking water supply, treatment and pumping of dirty water, etc.
- It has minimum head loss, it is 100% watertight, full bore and repackable under pipeline pressure.

11 - SERIES

RESILIENT SEAT GATE VALVES



GENERAL FEATURES:

- Minimum head loss.
- Full bore.
- Repackable under pipeline pressure.
- 100% watertight.
- Bidirectional flow.
- RF type DIN PN 10/16 flanges.
- Guided gate to ensure the correct sealing.
- Bolts protected against environmental conditions.
- WRAS certificate for drinking water.
- Max. working pressure according to design pressure PN10/16.
- Working temperature between -10°C and 90°C.

STANDARDS APPLIED:

- Design according to DIN 3352.
- Hydrostatic tests according to EN 12266-1, class A.
- EC Directive.
- Fabrication according to EN 1074-2.
- Distance between flanges according to EN 558 series 14.
- Side flanges according to ISO 7005-2.
- Top flange (optional) according to ISO 5211.

DIMENSIONS

DN	L (F4)	L (F5)	H	Torque (N-m)	Weight Kg. (F4)	Weight Kg. (F5)
40	140	240	205	32	9,0	10,5
50	150	250	218	40	10,6	11,8
65	170	270	255	52	11,0	12,2
80	180	280	277	64	12,6	14,35
100	190	300	325	80	18,0	20,2
125	200	325	355	100	26,9	32,7
150	210	350	395	120	30,2	34,8
200	230	400	482	160	53,0	64
250	250	450	572	200	73,5	87
300	270	500	662	240	107,4	146,4
350	290	---	830	300	166,3	---
400	310	600	915	345	210,8	250,6
450	330	---	960	400	300,0	---
500	350	700	1000	450	361,2	402,0
600	390	800	1050	540	570,2	642,0

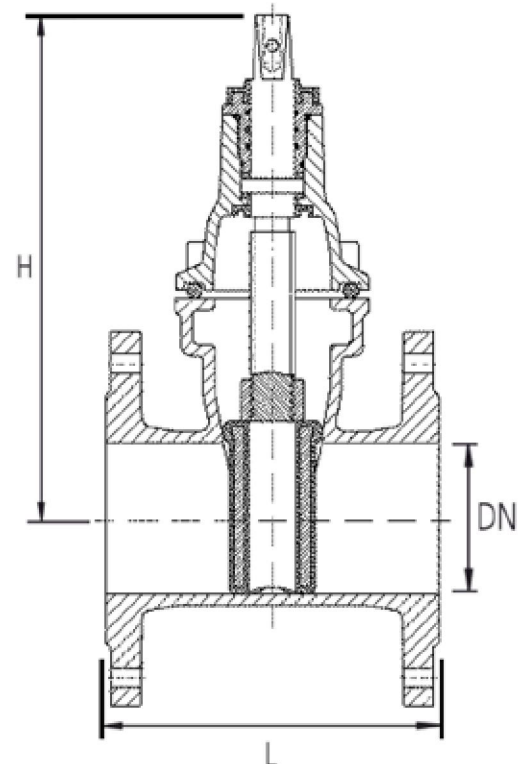

The images and drawings are non contractual.
The specifications of the shown products could vary without previous notice.

11 - SERIES

RESILIENT SEAT GATE VALVES

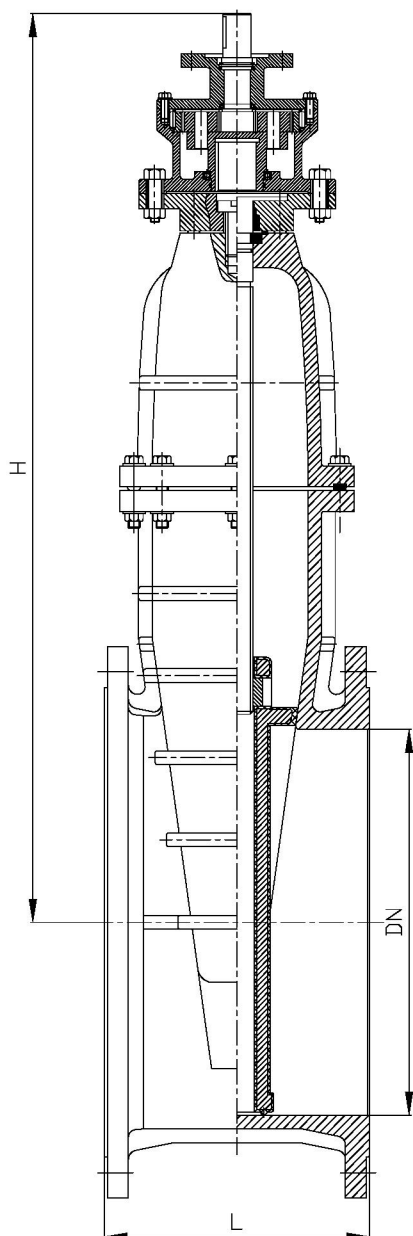

The valves of diameter over DN600 are supplied with gearbox.

These valves are only available with face to face distance according to EN 558-1 series 14 (F4).

DN	L	H	Weight Kg.	Top flange	Shaft	Hand-wheel
700	430	1491	840	F14	φ32	φ400
800	470	1663	1160	F14	φ32	φ400
900	510	1820	1560	F14	φ32	φ400
1000	550	2071	3020	F14	φ32	φ400



11 - SERIES

RESILIENT SEAT GATE VALVES

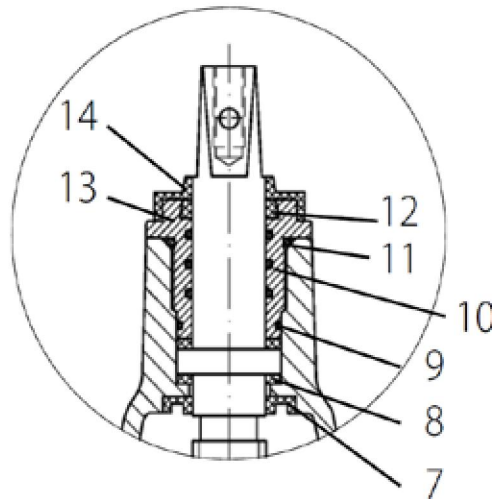
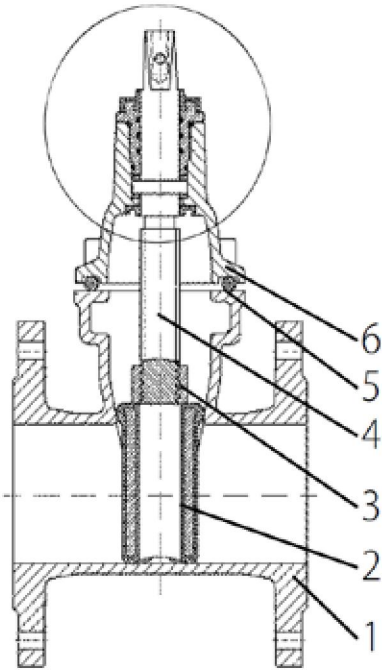

DESCRIPTION		
1	BODY	GJS500
2	GATE	GJS500+EPDM/NBR
3	NUT	BRASS
4	SHAFT	AISI 420
5	BODY-BONNET GASKET	EPDM
6	BONNET	GJS500
7	GASKET	EPDM
8	PACKING	PTFE
9	O-RINGS	EPDM
10	SHAFT-NET O-RINGS	NBR
11	O-RINGS	EPDM
12	O-RINGS	NBR
13	GLAND NUT	BRASS
14	DUST PROTECTOR	NBR
	PAINTING RAL 5015	Epoxy 250 µm



CMO VALVES
manufacturing the valve you need

Amategui Aldea, 142 - 20400 Tolosa - Guipuzcoa (Spain)
(+34) 943 67 33 99 - cmo@cmovalves.com - www.cmovalves.com

11 - SERIES

RESILIENT SEAT GATE VALVES



THREE-PHASE ACTUATION



DN	Bare shaft Torque (N·m)	Actuator
50	50	SA07.2
65	60	SA07.2
80	60	SA07.2
100	80	SA07.6
125	100	SA07.6
150	120	SA07.6
200	150	SA10.2
250	200	SA10.2
300	250	SA10.2
350	300	SA10.2
400	350	SA14.2
450	400	SA14.2
500	450	SA14.2
600	550	SA14.6
700	530	SA14.6
800	640	SA14.6
900	720	SA14.6
1000	800	SA14.6

A conical gearbox will be installed in the valve before the actuator.
These valves are manufactured with a top flange according to ISO5211, this can make the torque to change with respect to the design without the flange.

Certificate of Approval

This is to certify that the Management System of:

CMO VALVES Technology, S.L.

Amategi Aldea142, 20400 Tolosa - Guipuzcoa, Spain

has been approved by Lloyd's Register to the following standards:

ISO 9001:2015

Approval number(s): ISO 9001 – 0035593

The scope of this approval is applicable to:

Design, manufacturing and commercialization of knife and gate valves, check and butterfly valves.



Paul Graaf

Area Operations Manager, Europe

Issued by: Lloyd's Register Quality Assurance España, S.L.U.

for and on behalf of: Lloyd's Register Quality Assurance Limited



CE DECLARATION OF CONFORMITY DECLARACION DE CONFORMIDAD CE

In conformity with the requirements of the Directive EC 2014/68/UE PED, applicable to pressure equipments, we declare that our **WATER SUPPLIES valves** series:

11 - 12 - 13 - 21 - 22 - 23 - 24 - 25 - 31 - 32 - 33 - 35 - 51 - 53

are classified under Category I (Module A) for fluids of group 1 and 2 or Article 4.3

We issued this statement on our sole responsibility, responsibility for changes affecting the design or operation of the valve will not be accepted, once it has been provided without express acceptance of CMO. The design and manufacture of the pressure equipments, is performed following the EU legislation, under our internal procedures of manufacture, and the European standards:

EN 558
EN 1092
EN 12266
EN ISO 5210
EN 12516

*Conforme a los requerimientos de la directiva CE 2014/68/UE PED, aplicable a equipos a presión, declaramos que las **válvulas WATER SUPPLIES** series:*

11 - 12 - 13 - 21 - 22 - 23 - 24 - 25 - 31 - 32 - 33 - 35 - 51 - 53

se clasifican bajo la Categoría I (Módulo A) para fluidos del grupo 1 y 2, ó Artículo 4.3

Expedimos esta declaración bajo nuestra exclusiva responsabilidad, no se admitirán responsabilidades por modificaciones que afecten al diseño, o funcionamiento de la válvula, una vez haya sido suministrada y sin aceptación expresa de CMO. El diseño y fabricación de los equipos a presión se realiza siguiendo la legislación de la UE, bajo nuestros procedimientos internos de fabricación, y las normas europeas:

EN 558
EN 1092
EN 12266
EN ISO 5210
EN 12516

Signed / Firmado: **Pablo Gómez**
Position / Cargo: **General Manager**



Place and date / Lugar y fecha: **Tolosa, 04/04/2019**

Firma / Signature:

Certification of Products in contact with drinking water

By this certification, CMO Valves guarantees that all components of the valves on the following list, that are in contact with drinking water are WRAS approved material, so they can be used for drinking potable water.

SERIES 11A

SERIES 12A

SERIES 23A

SERIES 24A

SERIES 24B

SERIES 31A

SERIES 32A

SERIES 51A

SERIES 53A



Certified Quality
Management System

Signed / Firmado: CRISTIAN ARRABAL GALAN

Position / Cargo: Technical Director of CMO Valves Water Supplies



Place and date / Lugar y fecha: Tolosa, 21/09/2017

Firma / Signature