

reflecta Wall Mount Vesta 120RA

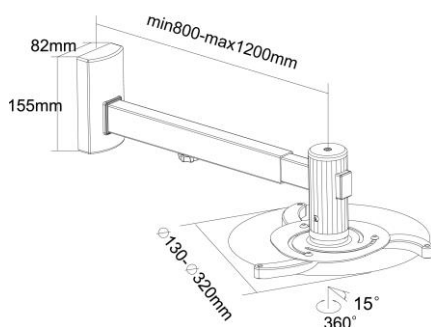

The professional **Vesta 120** Wall Mount is designed for the growing market of Interactive Whiteboards. reflecta introduces the **Vesta 120** as projector mount for Short Throw data-projectors which are preferred to project onto Interactive Whiteboards. The very solid construction enables a safety halt of the used data projector.

Productinformation

- Designed for Short Throw Projectors in combination with Interactive Whiteboards
- Solid steel construction
- Distance adjustment projector to board
- Universal projector adapter will fit the most data projectors
- Available in: 80-120 cm
- Cable management for HDMI cable

Technical Details

- Length: 800-1200 mm
- Max. weight Data Projector: 10 kg
- Tiltable: 15°
- Weight (without Data Projector): 2,5 kg

Delivery Content

- Mount + installation material + manual

Art.Nr. 23171

EAN Code: 4005039231711

Specifications are subject to change without notice



reflecta gmbh
 Merkurstrasse 8
 D 72184 Eutingen
 Phone: +49 (0) 7457 9465-60
 Fax: +49 (0) 7457 9465-72
 e-mail: mail@reflecta.de
 http: www.reflecta.de