



M A H A G R O U P

# MPJ 16.5/1200 2S | 3S

Pit Jack

Original Operating Instructions

BA551501-en

MPJ 16.5/1200 2S A  
MPJ 16.5/1200 2S A  
MPJ 16.5/1200 2S A

MPJ 16.5/1200 3S A  
MPJ 16.5/1200 3S A

BA551501-en  
2021-03-15

© MAHA Maschinenbau Haldenwang GmbH & Co. KG

The reproduction, distribution and utilization of this document as well as the communication of its contents to others without explicit authorization is prohibited. Offenders will be held liable for the payment of damages. All rights reserved in the event of the grant of a patent, utility model or design.

The contents of this edition have been checked with great care. However, errors cannot be fully excluded. Subject to technical change without notice.

**Manufacturer**

MAHA Maschinenbau Haldenwang GmbH & Co. KG  
Hoyen 20  
87490 Haldenwang  
Germany

Phone: +49 8374 585-0  
Fax: +49 8374 585-590  
Mail: [maha@maha.de](mailto:maha@maha.de)  
Web: [www.maha.de](http://www.maha.de)

**Service**

MAHA SERVICE CENTER  
Maybachstraße 8  
87437 Kempten  
Germany

Phone: +49 8374 585-100  
Fax: +49 8374 585-491  
Mail: [service@maha.de](mailto:service@maha.de)  
Web: [www.mahaservicecenter.de](http://www.mahaservicecenter.de)

## Contents

1	Safety.....	5
1.1	Symbols and Signal Words .....	5
1.1.1	Personal Injury.....	5
1.1.2	Property Damage .....	5
1.1.3	Information .....	5
1.2	Intended Use .....	6
1.3	Inappropriate Use .....	6
1.4	Requirements on Operating and Service Personnel .....	6
1.5	Safety Instructions for Operation .....	7
1.6	Safety Instructions for Handling Hydraulic Fluid .....	9
1.7	What to Do in the Event of Defects or Malfunctions .....	9
1.8	What to Do in the Event of an Accident.....	9
2	Description .....	9
2.1	Design and Operating Principle .....	9
2.2	Compressed Air Supply .....	10
2.3	Sample Nameplate .....	11
2.4	Technical Data .....	11
3	Transport and Storage.....	13
4	Installation and Initial Operation .....	13
5	Operation.....	20
5.1	Controls and Indicators .....	20
5.1.1	Double Telescopic Jack.....	20
5.1.2	Triple Telescopic Jack.....	22
5.2	Checking the Safety Device.....	24
5.3	General Operating Instructions for Lifting Accessories .....	24
6	Maintenance.....	26
6.1	Annual Inspection .....	26
6.2	Care Instructions .....	26
6.3	Refilling with Hydraulic Fluid.....	27
6.4	Maintenance by the Operator.....	28
6.5	Troubleshooting.....	30
6.6	Spare Parts.....	32
7	Service Lifetime .....	32
8	Dismantling .....	32
9	Disposal.....	32
10	Contents of the Declaration of Conformity .....	33



# 1 Safety

Thoroughly read this manual before operating the equipment and comply with the instructions. Always display the manual in a conspicuous location.

Personal injury and property damage incurred due to non-compliance with these safety instructions are not covered by the product liability regulations.

## 1.1 Symbols and Signal Words

### 1.1.1 Personal Injury



#### **DANGER**

indicates an immediate hazard which, if not avoided, will result in death or severe personal injury.

---



#### **WARNING**

indicates a potential hazard which, if not avoided, could result in death or severe personal injury.

---



#### **CAUTION**

indicates a potential hazard which, if not avoided, could result in moderate or minor personal injury.

---

### 1.1.2 Property Damage

#### **NOTICE**

indicates a potentially harmful situation which, if not avoided, could result in damage to the equipment or surrounding objects.

---

### 1.1.3 Information



indicates important information notes.

---

## 1.2 Intended Use

- The lift is intended for use in automotive workshops with passenger cars, commercial vehicles, buses, trailers and agricultural vehicles.
- Use in potentially explosive areas and outdoors is prohibited. Use in wet or flammable areas is only permitted with the express written permission of the manufacturer.
- Pit jacks and transmission jacks are lifting devices and are not suitable for holding the load safely over a longer period. Raised loads must be safely supported in a suitable manner.
- For vehicles that need to be lifted at two points, attachable axle crossmembers are to be used.
- Observe the maximum load carrying capacity set out on the rating plates of pit jack and load carrying equipment.
- The pit jack shall not be modified without the express written consent of the manufacturer. In case of non-compliance the declaration of conformity becomes void.

## 1.3 Inappropriate Use



### WARNING

Use in any manner other than that intended is prohibited, such as:

- Walking or climbing on the load carrying equipment
  - Using the load carrying equipment to transport personnel
  - Use for other lifting work
- 

## 1.4 Requirements on Operating and Service Personnel



### WARNING

All persons employed in the operation, maintenance, installation, removal and disposal of the device must

- be at least 18 years old,
  - be mentally and physically suited for these activities,
  - be demonstrably trained and instructed in writing,
  - have read and understood the operating instructions, especially the instructions what to do in the event of defects or malfunctions,
  - be on record as having been instructed in safety guidelines,
  - have practical experience in working with vehicle lifts and the hazards inherent in such equipment.
-

## 1.5 Safety Instructions for Operation



### WARNING

- All loose parts within the packaging must be secured by trained personnel and in compliance with the work plans.
- Observe transport guidelines; load suspension points are defined and marked on the packaging.
- Work plans for packaging, suitable transport equipment and slings must be available and used during final assembly.
- Transport only by trained personnel and with suitable special tools.
- Observe the information on the packaging about possible hazards during assembly or about correct handling.
- The jack may only be operated by trained persons who have reached the age of 18.
- The operator is responsible for ensuring that the operator has been instructed and is familiar with the operating instructions.
- The operator must check the safety devices before commissioning.
- The load capacity specified on the type plate must not be exceeded.
- When driving a vehicle up and down the pit of the jack, no persons shall be in the danger zone.
- Positioning of the jack under the load may only be carried out by trained personnel.
- The vehicle or vehicle components may only be picked up at the points provided for this purpose.
- After briefly lifting the vehicle free by the jack, check that the vehicle is securely picked up.
- Never work under unsecured loads!
- Load and jack must be observed by the operator during the lifting and lowering process.
- Riding with the load or on the load handling attachment is prohibited.
- If the operator does not have a complete overview of the danger zone, it must be monitored by a second person who has been instructed.
- During the lifting and lowering process, no persons may be in the range of movement of the jack and load.
- After completing the lifting operation, remove the pump control lever or foot pedal and place it in the designated location.
- The load may only be lifted at the centre of gravity; the vehicle must be able to roll during the lifting and lowering movement. This allows the load to center itself over the jack.
- Loads must be applied to the load handling attachment in such a way that unintentional changes in position are prevented.
- Reliably support loads on outriggers immediately after lifting.

- If adjustable mounting plates are available, height differences of the mounting points must be compensated.
  - It is not permitted to work under the lifted load unless it is secured by suitable means (DIN EN 1494).
  - The lifter must always be moved with both hands. If the required manual force cannot be provided by one person, another person shall be called in.
  - During all movements of the pit lift, the operators must ensure that they do not endanger themselves or others.
  - If the floor is uneven in the area of the jack, it must be secured against rolling away.
  - Use of the jack on a surface with a slope of more than 6° is not permitted.
  - No tools or other objects may be placed on the lifting devices of the jack.
  - The jack may only be moved with a load when it is retracted. It must be ensured that the load is picked up at the centre of gravity and secured in a suitable manner on the load handling attachment (e.g. by lashing straps).
  - When installing and removing heavy vehicle components (engine/aggregates), the position of the centre of gravity may change. In this case, suitable measures (determination of the centre of gravity, checking of the pick-up point) must be taken to prevent tipping before the jack is lifted again.
  - Before lowering, the operator must ensure that there are no objects in the movement range of the jack and load.
  - Load handling attachments must not be deliberately set in vibration.
  - As the chassis is not secured against tipping on the ground, side loading is generally prohibited.
  - The oil level in the hydraulic system must be checked regularly by trained personnel.
  - The completeness and legibility of the safety instructions on the jack must be checked annually.
  - In the event of malfunctions, the range of movement of the jack and load must be secured. Take the jack out of operation and notify customer service.
  - The operator must ensure suitable lighting conditions at the workplace.
  - In order to avoid unattended lifting of the load (possibly due to a leaking valve), it is essential to disconnect the jack from the compressed air supply or shut off the compressed air supply line at the end of operation.
  - The hydraulic components must be checked annually.
  - Personal protective equipment must be worn.
  - The pressure relief valve must not be adjusted above the value specified by the manufacturer and only by authorized personnel.
  - Troubleshooting is only allowed by authorized personnel.
  - Observe the notes on correct assembly and disassembly in the operating instructions.
-



## 1.6 Safety Instructions for Handling Hydraulic Fluid



### CAUTION

- Neutralise hydraulic fluid spills with binder.
  - Remove contaminated clothing immediately.
  - Inhalation: If symptoms persist, seek medical treatment.
  - Skin contact: Wash skin immediately with soap and water. If skin irritation persists, seek immediate medical advice.
  - Eye contact: Rinse thoroughly with water and seek medical advice.
  - Ingestion: Do not induce vomiting. Seek immediate medical attention.
- 

## 1.7 What to Do in the Event of Defects or Malfunctions



### WARNING

- If defects occur, such as the pit jack raising and lowering itself on its own or distortion of the supporting components, immediately lower the lift or provide support.
  - In case of malfunction or repair disconnect the pit jack from the air supply system.
  - Turn off the main switch and secure to prevent unauthorized use. Contact the Service Department.
- 

## 1.8 What to Do in the Event of an Accident

- The injured person is to be removed from the danger area. Find out where dressing and bandages are kept. Seek first-aid.
- Provide first-aid (stop bleeding, immobilise injured limbs), report the accident and seal off the accident site.
- Immediately report any accident to your supervisor. Make sure a record is kept of every occasion first-aid is provided, e.g. in an accident book.
- Remain calm and answer any questions that may arise.

## 2 Description

### 2.1 Design and Operating Principle

These pit jacks are based on the synchronous principle of all telescopic stages. These hand-hydraulic, hydraulic/pneumatic combined or pneumatic pit jacks / axle and transmission jacks are lifting devices for lifting vehicles and component units. The pit jack can be moved longitudinally and transversely via a carriage, the axle and gear jack via a floor-running carriage with rollers.

The pump block contains load, suction and overload valves. The low pressure foot pump is mounted according to the spare parts list. The self-closing

lowering screw is also mounted on the pump block. An overflow system is installed for automatic bleeding.

An attached support disk (bracket/gear plate) serves as the load carrying device. For special lifting points on vehicles, other suitable supports from our range of accessories can be fitted.

In the case of hydraulic-pneumatic pit jacks with rapid control, the oil in the tank is pressurised by compressed air. This displaces the oil and the piston quickly reaches the lifting point.

In the version with air motor (LM), this unit is located on the right-hand side (the high-pressure side). It is driven by compressed air and transports the oil.

**H carriages** are mounted in a suspended position.

**X carriages** can be moved freely and are used in pits as well as under vehicle lifts for raising and lowering units. In the case of type **X**, the jack is permanently mounted on the carriage.

**F / U / Z carriages** are designed exclusively for use in pits. The carriage is held in its fixed track by flanged or deflector rollers. In addition, the jack can be moved in the carriage at right angles to the pit.

The rollers run directly on the floor or on rails or in steel profiles. The running surface must be even, firm and clean. The ground slope must not exceed 2%.

## 2.2 Compressed Air Supply

### **NOTE**

Connect pneumatically actuated jacks to a suitable compressed air supply. They may only be operated with dry, lubricated compressed air according to ISO 8573-1:2010 [1:4:2].

---

## 2.3 Sample Nameplate



## 2.4 Technical Data

	MPJ 16.5/1200 2S	MPJ 16.5/1200 3S		
Drive	9...10 bar at 350 l/min			
Net weight of jack	210 kg	272 kg		
Stroke	1200 mm			
Max. lifting height in X carriage	2077 mm	1883 mm		
Noise emission	< 78 dB (A)			
Load capacity	16,500 kg			
Ambient temperature	+5 to +40 °C			
Internal diameter (pin)	45 mm			
Outside diameter (piston rod)	80 mm			
<b>Heights</b>				
- X carriage (without load carrying device)	867 mm	683 mm		
- U / F carriage (without load carrying device)	858 mm	674 mm		
	<b>Carriage</b>	<b>B dimension</b>	<b>Width b</b>	<b>Net weight</b>
A	H	max. 1200 mm	680 mm	max. 200 kg
B	F / U / Z	max. 1742 mm	1026 mm	max. 300 kg
C	X	1010 mm	760 mm	90 kg

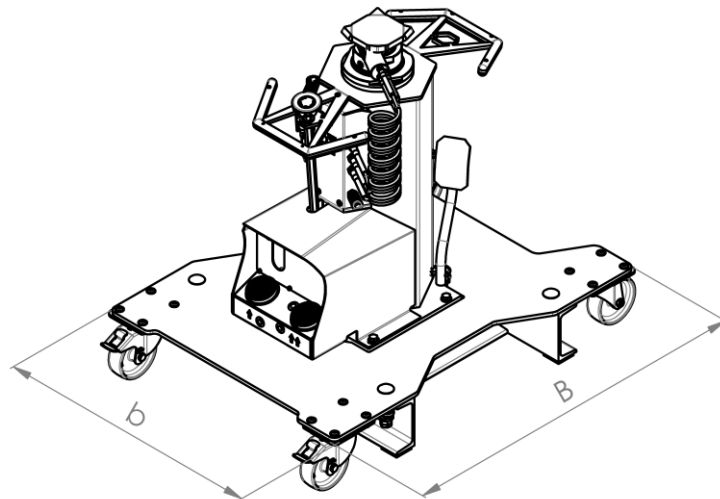
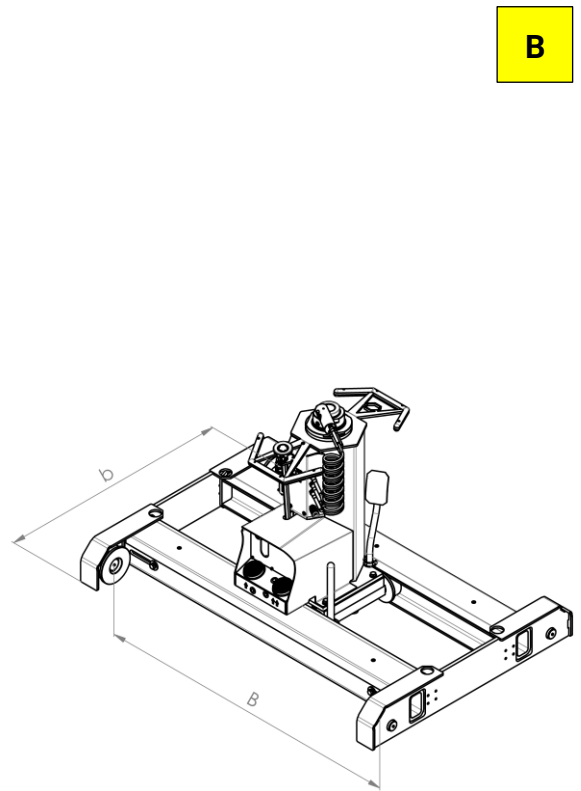
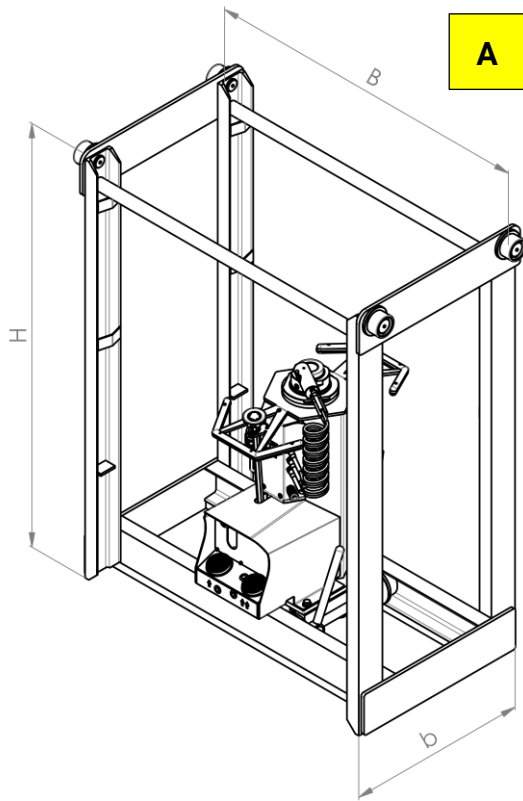

### 3 Transport and Storage

#### NOTICE

Check package to ensure it is complete, in accordance with the order confirmation. Report any transport damage to the carrier immediately.

During loading, unloading and transport always use suitable lifting equipment, material handling equipment (e.g. cranes, forklifts, etc.) and the right load handling attachments and slings. Always ensure that the parts to be transported are suspended or loaded properly so that they cannot fall, taking into account size, weight and the centre of gravity.

Store the packages in a covered area, protected from direct sunlight, at a low humidity and with temperatures between 0...+40 °C (32...104 °F). Do not stack packages.

When unpacking, take care to avoid any possibility of injury or damage. Keep at a safe distance when opening the package strapping, do not allow any parts to fall out.

---

### 4 Installation and Initial Operation



#### WARNING

Installation and commissioning of the equipment must be carried out by specially trained personnel, authorised for the task. Specialist personnel includes authorised, trained skilled staff from the manufacturer, the dealer and the relevant service partners.

---

- 1 • Completely remove the packaging from jack and carriage.  
**IMPORTANT:** The carriage is matched to the pit specified in the order. Use in other pits is only permitted after consultation with the manufacturer.
- For reasons of work safety, the jack must be disconnected from the carriage during the installation process. To do this, loosen all four hex screws (A) as marked in Fig. 1. When using the telescopic jack, make sure that the cover is secured.
- Using a suitable hoist, lift the jack out in the upright position as it sits in the carriage and place it on level ground.

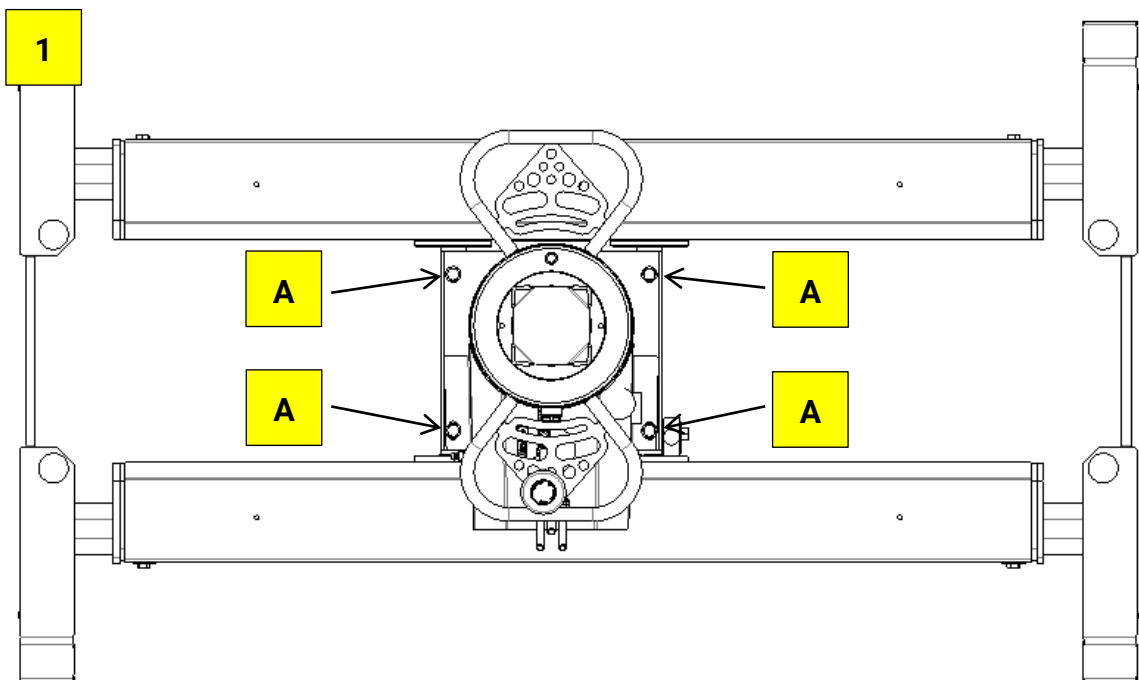

- 2**
- Secure the freely moving axles against uncontrolled movement in the carriage.
  - Lower the carriage and jack into the pit using a suitable hoist.

2

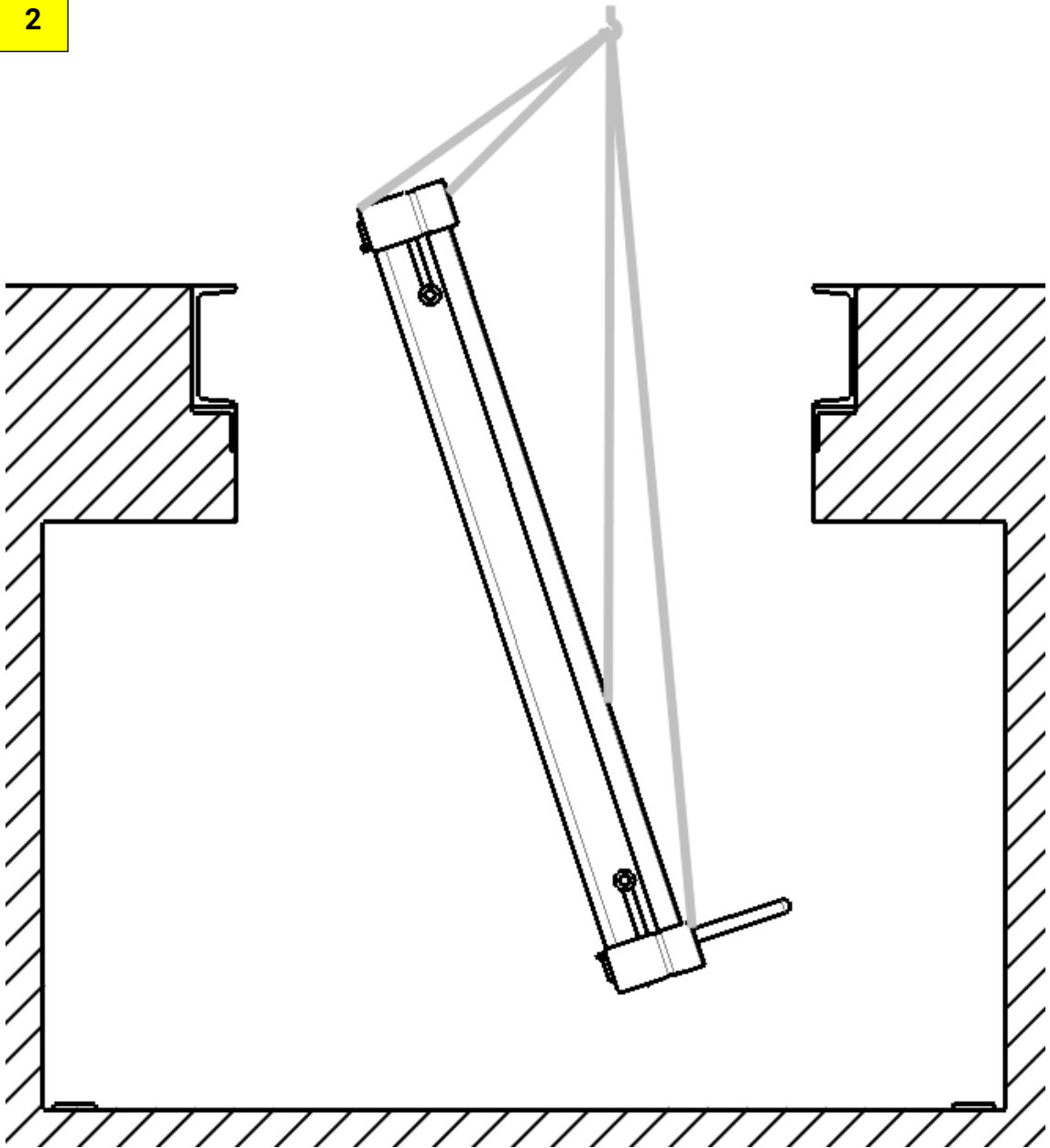

Schematic diagram: Suitable slings must be used!

- 3**
- Set the adjustable side parts of the carriage to the respective pit dimension. To do this, loosen the hex screws (B). Make sure that both side parts are extended as far as possible (see dimension "X").
  - Secure the extensions with hex screws (B). Set a tightening torque of  $50 \pm 5$  Nm.

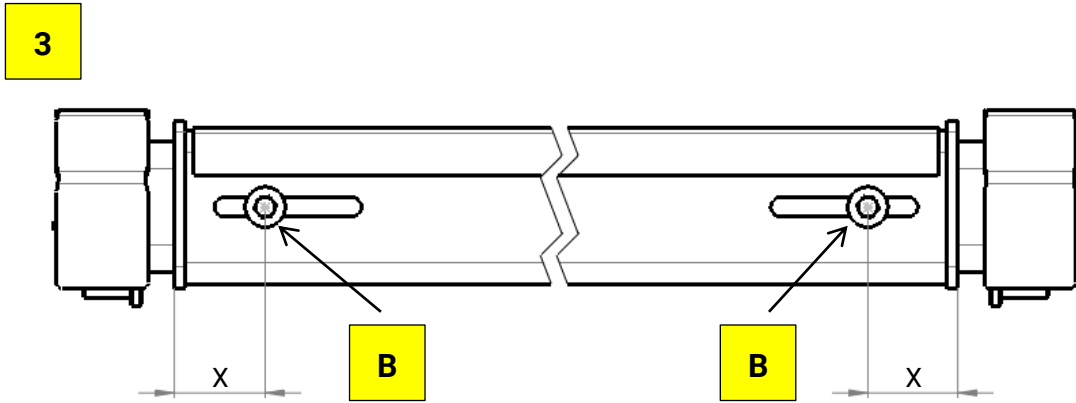



- 4**
- Mount the jack on the carriage in reverse order to disassembly (step 1). Tighten the four hex screws (A, Fig. 1) with a tightening torque of  $85 \pm 5$  Nm to fix the jack.
  - For all carriage variants, note that the collar of the carriage rollers or the entire carriage in particular must be able to move freely over the entire pit length.

**4.1** F carriage

**4.2** UZ carriage

**4.3** UK carriage

**4.4** Z carriage

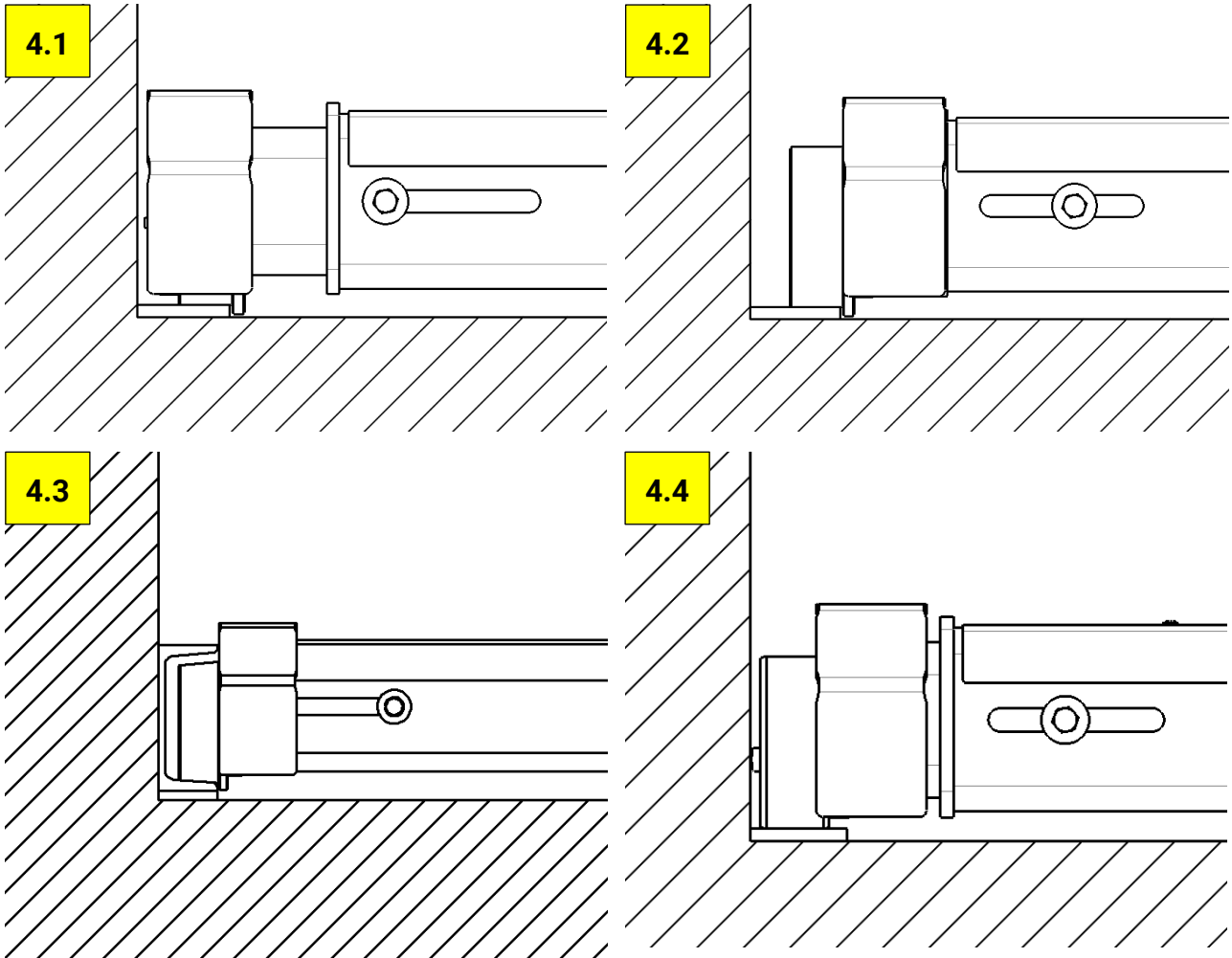

- 5** • For carriage variants Z, adjust the deflector rollers to the pit width and fix them in place by hand-tightening the cylinder screws (C).  
The carriage rollers must run securely on the rails over the entire pit length.

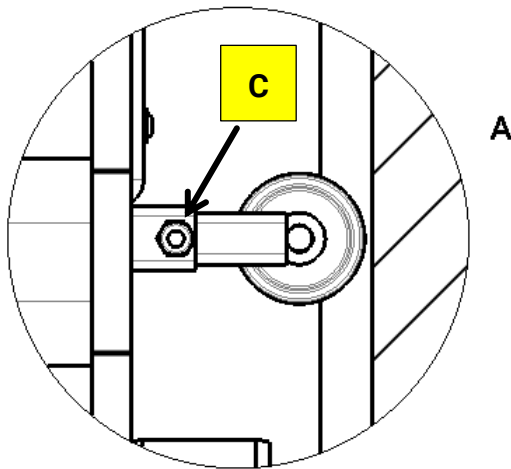
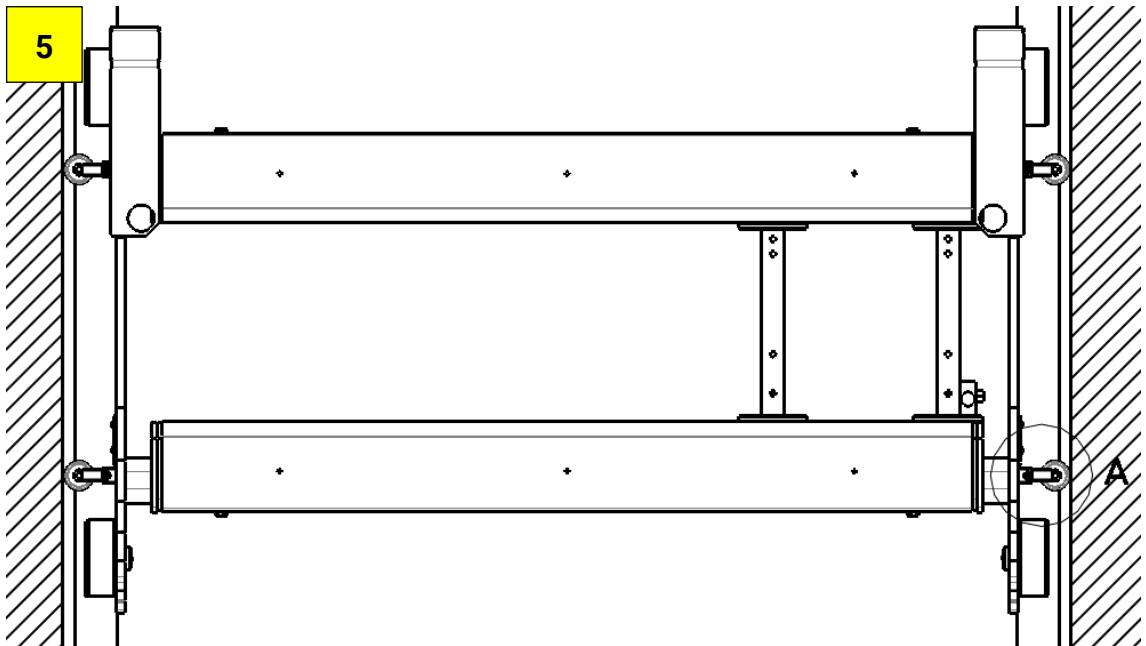

- 6** • If replacements are necessary, note the mounting position of the carrier.

**a** Top

**c** Tracks of the jack rollers

**b** Bottom

**6**

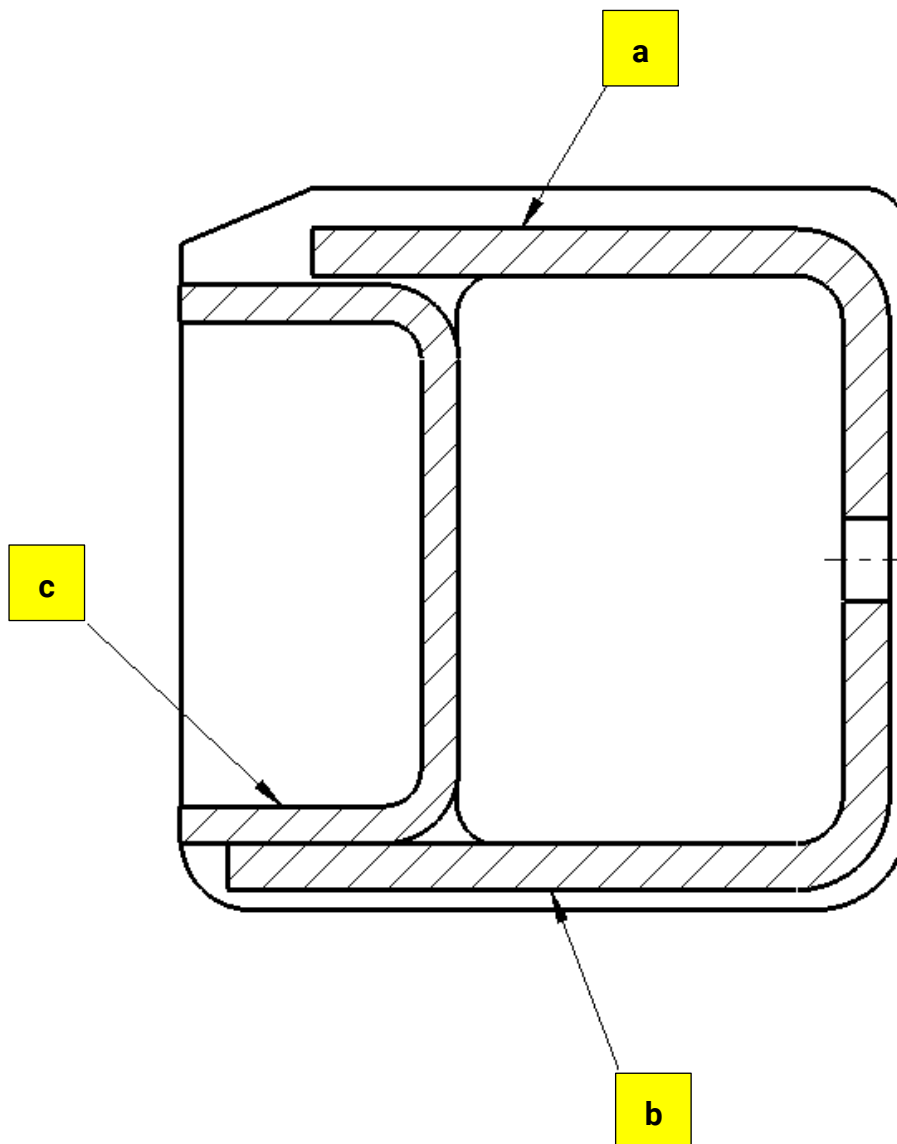

## 5 Operation

### 5.1 Controls and Indicators

#### 5.1.1 Double Telescopic Jack

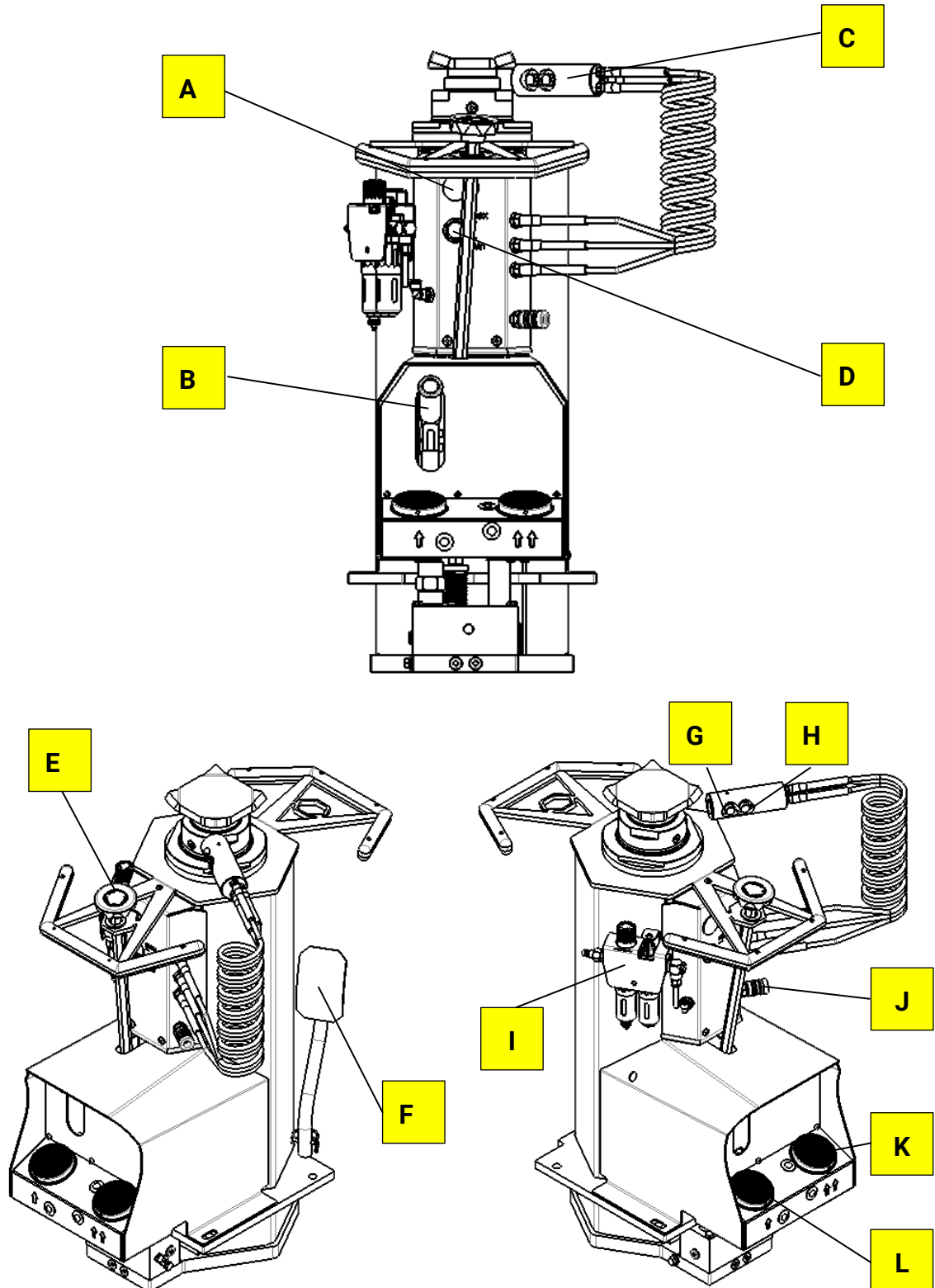

- A** Oil filler plug
- B** Foot pump
- C** Handheld remote control with magnetic holder
- D** Oil sight glass
- E** Lowering spindle
- F** Foot pedal
- G** Load lift control (manually operated)
- H** Rapid control (manually operated)
- I** Maintenance unit
- J** Quick coupler
- K** Rapid control (foot operated)
- L** Load lift control (foot operated)

## 5.1.2 Triple Telescopic Jack

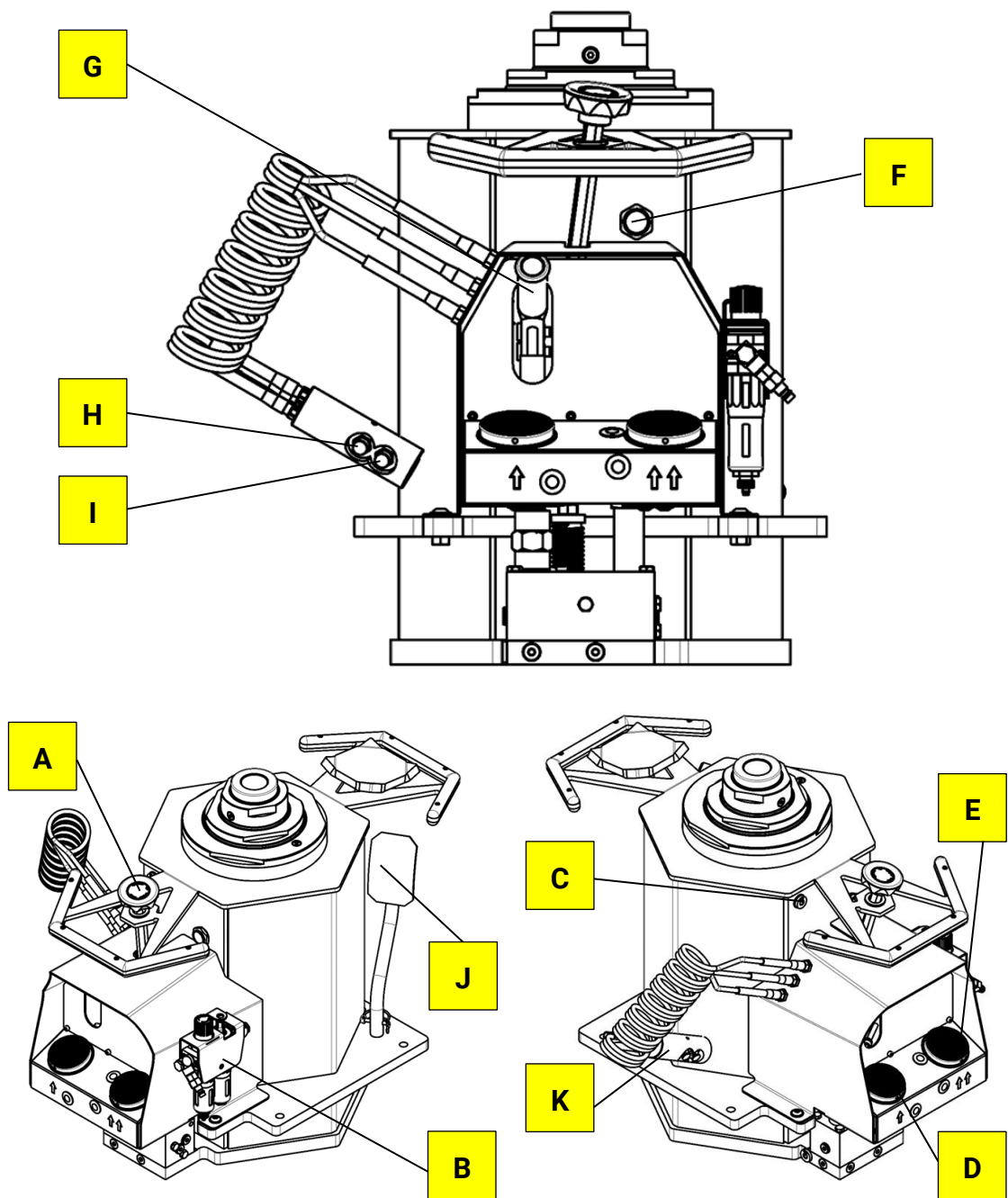

## Standard scope of delivery

- A Lowering spindle
- B Maintenance unit
- C Oil filler plug
- D Load lift control (foot operated)
- E Rapid control (foot operated)
- F Oil sight glass

## Option

- G Foot pump
- H Rapid control (manually operated)
- I Load lift control (manually operated)
- J Foot pedal
- K Handheld remote control with magnetic holder

- **Unloaded rapid lift**

By actuating the rapid control (foot pedal or remote control) the piston rod extends to the lifting point (axle, gearbox).



### WARNING

Depending on the air pressure and the lifting height reached, the piston rod extends a little further after the button is released.

Danger of crushing between piston rod/load handling attachment and vehicle.

---

- **Load lift**

Load lift is controlled via load lift control (foot pedal or remote control).

- **Lowering under load**

When lowering under load, the lowering valve must only be opened by slow, slight counterclockwise rotation of the lowering spindle in order to achieve a controlled lowering movement.

- **Lowering without load**

Open the lowering spindle by turning it counterclockwise as far as it will go, this actuates the lowering valve and the piston rods are retracted.

- **Hand-held remote control with magnetic holder (option)**

The remote control can be attached to the pit jack via a magnetic holder (e.g. on the base body, cover hood, carriage).

## 5.2 Checking the Safety Device



### WARNING

The safety device must be checked by operating the lowering spindle (A):

- 1 Turn the lowering spindle counterclockwise.
  - 2 Release the lowering spindle, it must return to its initial position.
  - 3 In addition, check the torsion spring for corrosion and damage.
- 

## 5.3 General Operating Instructions for Lifting Accessories



### WARNING

- Support tubes must not be extended. Risk of tilting!
  - Danger of crushing at the edge of the pit and support bridge!
  - The support system shall only be removed if the vehicle is in a secure stable position.
  - Beware of changes in the centre of gravity of the load, e.g. in case of different amounts of fuel in asymmetric fuel systems. If necessary, use suitable lifting accessories.
  - Take note of the operating instructions of all equipment and tools used.
  - Check lifting accessories carefully for operational safety.
  - Pre-position the lift and lifting accessory at the lift points.
  - Always take up the load securely, without risk of slipping and central to the centre of gravity.
  - Position actuators, supports and bases at the support points and depending on type, fix support pipes with pins and secure with cotter pins or wooden blocks with a minimum spacing of 500 mm.
  - Slowly raise or lower the load, watching it continuously.
  - Set down the load without risk of slipping and central to the centre of gravity.
-



## Permissible Extension for Pit Jack and Support Systems

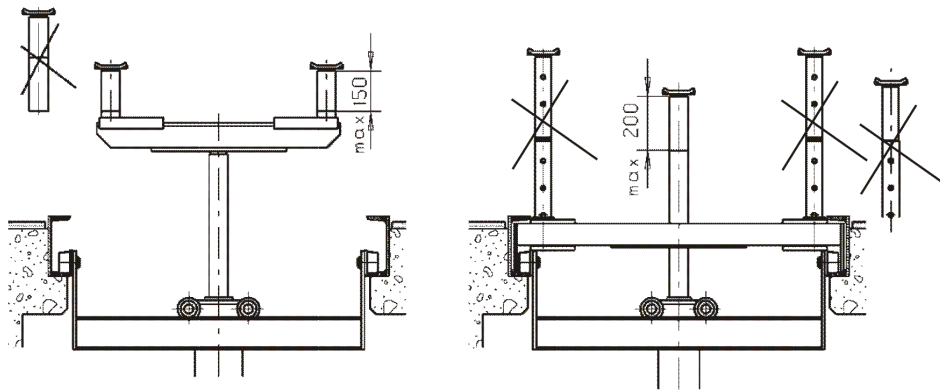
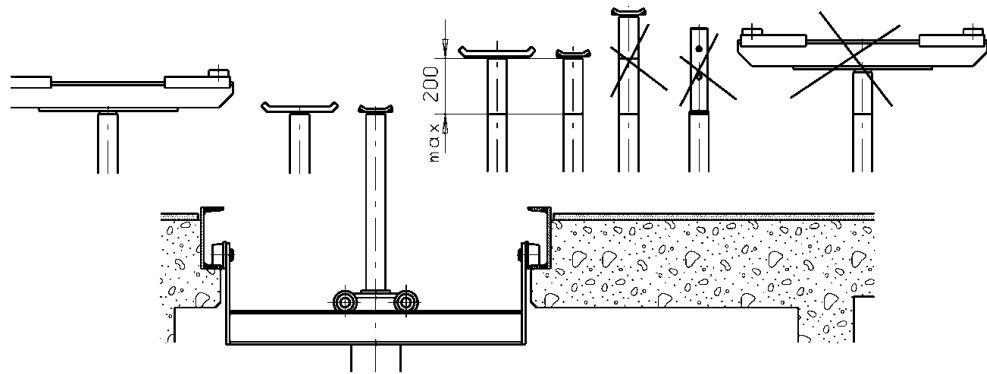

## 6 Maintenance

### 6.1 Annual Inspection



- The maintenance interval prescribed by the manufacturer is 12 (twelve) months. This maintenance interval refers to normal workshop usage. If the equipment is used more frequently or under severe operating conditions (e.g. outdoors), the interval must be reduced accordingly.
  - Maintenance work shall be done only by authorised and trained service technicians provided by the manufacturer, licensed dealers or service partners.
  - In case of non-compliance the manufacturer's warranty becomes void.
- 

### 6.2 Care Instructions

- Periodically clean the equipment and treat it with a care product.
- Repair damage to the paintwork immediately to prevent corrosion.
- Do not use caustic cleaning agents or high pressure and steam jet cleaners to avoid equipment damage.



Regular care and maintenance is the key condition for functionality and long life expectancy of the equipment!

---

## 6.3 Refilling with Hydraulic Fluid

For measuring and refilling, the piston rod must be fully **retracted** and the siphon must be disconnected from the air or power supply. The oil level must cover the oil sight glass at least halfway. If no oil is visible on the sight glass, hydraulic oil must be topped up.

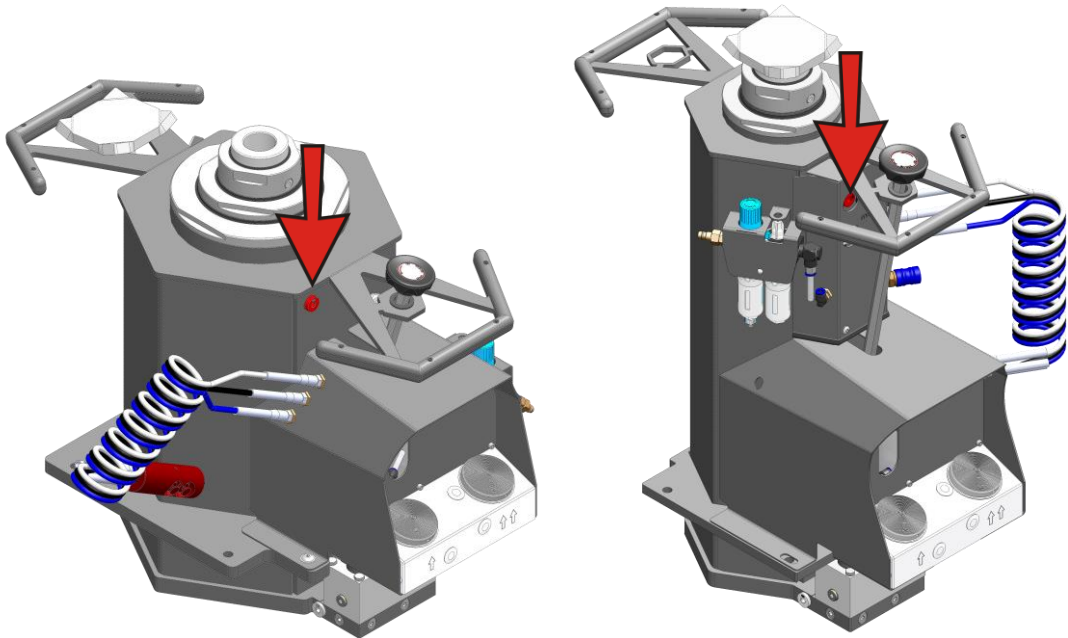

- Replace the hydraulic oil depending on ageing, water absorption and contamination, but after six years at the latest.
  - Only use hydraulic oil of the same specification for refilling.
  - If the jack is operated permanently at an ambient temperature of  $< 15\text{ }^{\circ}\text{C}$ , a hydraulic oil with a lower viscosity must be used.
  - The pressure hoses should be replaced as required, but must be replaced after six years at the latest. Record the exchange in the inspection book.
-

## 6.4 Maintenance by the Operator

- **The jack must be extended to full lifting height at least once a week and pumped through a few times with the lowering spindle closed. This will automatically bleed it and remove the accumulated leakage oil.**
- After washing, oil all bare and all moving parts.
- Piston rod, load support pins, rollers and other moving parts must always be lightly oiled.
- Regularly lubricate the carriage via the grease nipples on the rollers (8 pcs).
- Residues of underbody protection and other impurities can destroy the seals. Clean the piston rod regularly! Damage to the piston rod must be ground out immediately with a soft transition. Cleaning agents and salt water can penetrate unhindered and cause great damage on the inside.
- Water is harmful! A compressed air maintenance unit, consisting of a compressed air filter, water separator and oil nebuliser, must be available in the compressed air system near the jack (max. distance: 5 m). Drain maintenance unit weekly, check oil level and check for function. Keep the maintenance unit clean.
  - Adjustment of the maintenance unit:  
The oil nebuliser must be adjusted so that approx. 1 drop of oil is consumed per stroke. This is done by means of a slotted screwdriver which is inserted through the opening in the pneumatic cover plate. The drainage quantity or the oil level can be conveniently checked through the metal protection basket of the maintenance unit. The oil reservoir can be removed and filled by turning it 90° to the left and then pulling it downwards. Installation in reverse order!
  - Filling the maintenance unit:  
To refill the oil reservoir of the maintenance unit, the jack must be completely lowered, pressure-free and disconnected from the compressed air supply! The oil reservoir can be removed and filled by turning it 90° to the left and then pulling it downwards. Installation in reverse order!



A so-called refrigeration dryer is not sufficient for compressed air maintenance! A refrigeration dryer cannot filter out the line dirt and does not supply the equipment with the oil film that is important for trouble-free operation (see section: "Compressed Air Supply").

- 
- In the event of failure to comply with these instructions, the manufacturer will not provide a guarantee in the case of damage caused by rust, dry running and line dirt.
  - Observe technical information on maintenance and servicing instructions.

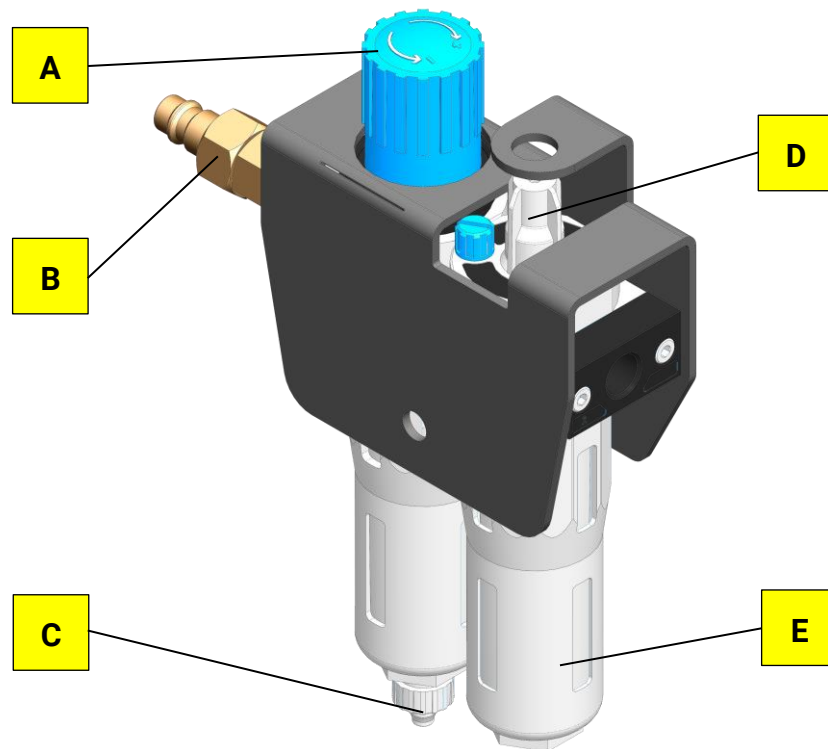

- A** Pressure gauge
- B** Air connection with pre-filter
- C** Condensate drain
- D** Oil regulating screw
- E** Oil sight glass of the maintenance unit

## 6.5 Troubleshooting

Error	Cause	Remedy
Air motor is running (typical noise), but does not raise load	Lowering spindle not fully closed; spring not fully closed	Close lowering spindle
	Fluid level too low due to shipping damage or normal consumption	Top up hydraulic fluid
	Suction valves leaking	Contact service
Air motor is running (typical noise), but does not raise load completely	Lowering spindle not fully closed; spring not fully closed	Close lowering spindle
	Overload valve triggered; load too heavy	Reduce load; observe rated load capacity
	Load valves leaking	Contact service
Air motor is running when unloaded (typical noise), but gets increasingly slower under load and finally comes to a stop	Air motor running dry; no oil in the maintenance unit	Top up oil
	Air pressure too low; local cause	Contact service
	Valve levers blocked; mechanical (local) cause	Contact service
	Control or valve blocked by dirt and debris	Clean
Air motor is raising load to a certain height and then pumping dry	Fluid level too low due to shipping damage or normal consumption	Top up hydraulic fluid
Air motor is raising load to a certain height and then gets increasingly slower	Air filter plugged; dirt from supply network	Clean
	Air pressure too low; local cause	Contact service
	Air flow rate too low; local cause	Contact service
Air motor is raising load to a certain height, then gets increasingly slower and finally comes to a stop	Air pressure too low; local cause	Contact service
	Control or valve blocked by dirt and debris	Clean
Air motor running very slowly, even in idle gear	Air filter plugged; dirt from supply network	Clean

<b>Error</b>	<b>Cause</b>	<b>Remedy</b>
	Air motor running dry; no oil in the maintenance unit	Top up oil
	Air pressure too low; local cause	Contact service
Air motor not running at all	Air filter plugged; dirt from supply network	Clean
	Air motor running dry, comes to a stop; no oil in the maintenance unit	Top up oil
	Air motor defective	Replace
Rapid lift control does not work	Air filter plugged; dirt from supply network	Clean
	Valve levers blocked; mechanical (local) cause	Contact service
	Valve levers broken; mechanical cause	Contact service
Load is lowering when in raised condition	Lowering spindle not fully closed; spring not fully closed	Close lowering spindle
	Load valves leaking	Contact service
Unloaded rams are raising slowly at first, then get suddenly faster	Fluid level too low due to shipping damage or normal consumption	Top up hydraulic fluid
Rams are "rattling"; inaccurate controlling	Fluid level too low due to shipping damage or normal consumption	Top up hydraulic fluid
	Hydraulic system must be bled	Contact service
Leakage at ram bleeder	If leakage remains limited = no error	Fully raise the ram in regular intervals to eliminate any leaked oil accumulation
Leakage at valves	Too much oil from maintenance unit	Set lower
	Oil dilution by water from compressed air	Check maintenance unit
Leakage at spindle guide	Mechanical seal wear	Contact service
Leakage at sealing plug	Sealing plugs leaking	Contact service

Error	Cause	Remedy
Leakage at air motor	Too much oil from maintenance unit	Set lower
Leakage at pump block	Mechanical seal wear	Contact service

## 6.6 Spare Parts

To ensure safe and reliable operation, only use original spare parts supplied by the equipment manufacturer.

## 7 Service Lifetime

In its standard version, this product is designed for 22,000 load cycles based on EN 1493. The maximum period of normal use in relation to the possible product life expectancy shall be evaluated and scheduled by a qualified person during the annual safety inspection.

## 8 Dismantling

Decommissioning and dismantling of the equipment may be done only by specially authorized and trained personnel provided by the manufacturer, licensed dealers or service partners.

## 9 Disposal

If you want to dispose of the equipment, please contact your MAHA dealer or the following address, indicating equipment type, date of purchase and serial number:

MAHA Maschinenbau Haldenwang GmbH & Co. KG  
Hoyen 20 | 87490 Haldenwang | Germany

Phone: +49 (0) 8374 585 0

Fax: +49 (0) 8374 585 500

Email: [info@maha.de](mailto:info@maha.de)

Alternatively, you may take the equipment to a specialised waste management plant to ensure that all components and operating liquids are properly disposed of.



## 10 Contents of the Declaration of Conformity

### MAHA Maschinenbau Haldenwang GmbH & Co. KG

herewith declares as a manufacturer its sole responsibility to ensure that the product named hereafter meets the safety and health regulations both in design and construction required by the EC directives stated below.

This declaration becomes void if any change is made to the product that was not discussed and approved by named company beforehand.

**Model:** MPJ 16.5/1200 2S FA MPJ 16.5/1200 3S FA  
MPJ 16.5/1200 2S TA MPJ 16.5/1200 3S TA  
MPJ 16.5/1200 2S HA

**Designation:** Pit Jack; Rated Load Capacity 16 500 kg

**Directives:** 2006/42/EC

**Standards:** DIN EN 1494





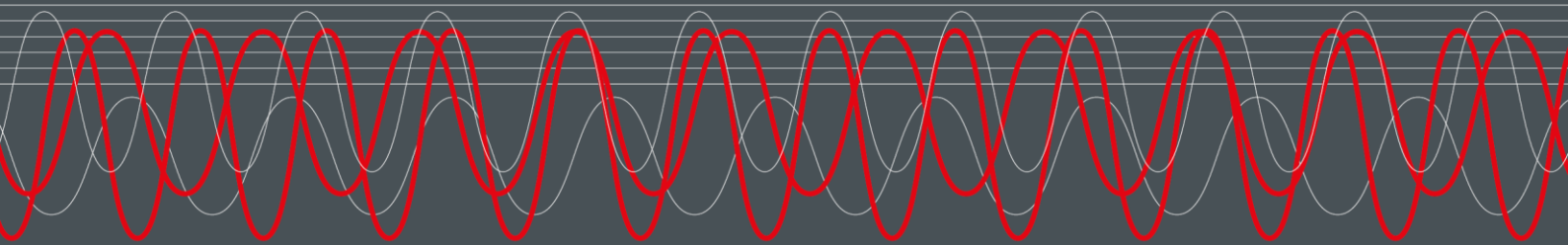

**MAHA MASCHINENBAU HALDENWANG GMBH & CO. KG**

Hoyen 20  
87490 Haldenwang  
Germany

☎ +49 8374 585 0  
✉ [maha@maha.de](mailto:maha@maha.de)  
🌐 [maha.de](http://maha.de)