

**LLC "Termomir"**

**METER - REGULATOR BP-10**

**Operating instructions**

**TMIR.421413.114 NOT**

**Lviv 2024**

This operating manual (hereinafter referred to as the manual) is intended to familiarize service personnel with the technical characteristics, composition, structure, operation, storage, operation and disposal rules of the BP-10 meter-regulator (hereinafter referred to as the regulator).

Please note that technical improvements to the regulator may sometimes lead to minor, non-essential differences between the design, the regulator diagram, and the text of this manual.

Trouble-free and long-term operation of the regulator is ensured by its correct operation in accordance with this manual.

The level of special training of service personnel is not lower than that of a 6th-class electrician.

## 1. Job description

### 1.1 Purpose

1.1.1 The controller is designed for measuring, automatically regulating and signaling temperature or other physical quantities of various technological processes. It is possible to implement regulation in timer mode. Also in The controller has an RS485 interface (possibly USB).

Regulator BP-10Ex explosion-proof version (explosion protection marking **II 2(1)G Ex db [ia Ga] IIC T5 Gb**) intended for use in Zone 1, where a potentially explosive gas environment of subgroup IIC, temperature class T5, is possible, made with type of protection "d", which provides protection level Gb and contains a protective device with output intrinsically safe circuits of level "ia", which are connected to level Ga equipment intended for use in potentially explosive gas environments of the subgroup.

The BP-10Ex regulator can measure and regulate the temperature of the explosive zone environment.,,0“complete with a TOP-109-52 thermal converter, which meets the requirements of DSTU EN 60079-0:2019 (clause 5.7)"Simple devices" („Simple apparatus“) with a length of the connecting cable between them is no more than 200m.

BP-10 regulators with index A (for nuclear power plants) withstand more severe operating conditions and have increased reliability indicators.

1.1.2 The regulator has three regulatory laws:

- two-position with the ability to signal when the measured value exceeds the set limits (or, conversely, when it enters the set limits);
- three-position;
- proportional-integral-derivative (PID) with the ability to signal when the measured value exceeds the set limits (or, conversely, when it enters the set limits).

**Note.** It is possible to implement a PID controller, including for working with valves, in which there are no two- and three-position controls.

The regulator output is dual-channel (in a single-channel regulator for two-position and PID regulation, the second channel is used for signaling) and is implemented with two identical or different output options (output signals):

- contacts of an electromagnetic relay with a power of 100 W or more at a switching voltage of 220 V at a frequency of 50 Hz;
- opto-symmetry output with a maximum switched voltage of 600 V and a current of 1 A (duration 100  $\mu$ s) (switching occurs when the alternating voltage value "crosses through zero") or a three-phase opto-symmetry output;
- transistor switch with a maximum switched voltage of 30 V and a current of 50 mA (or more);
- active switched output with an output signal of at least 5 mA or 10 V;
- analog output 0÷5, 0÷20 or 4÷20 mA;
- triac output of 5 A or more (determined by order) at 220(380) V.

**Note.**

A. The PID control law in a controller with a switched output is implemented by a pulse

signal, in which the duty cycle of the pulses is the variable (pulse-width modulation is present).

B. It is possible to implement a single-channel regulator output, in which there is no alarm and three-position regulation, or the alarm status is displayed only by the LED.

1.1.4 The regulator works in conjunction with primary converters:

- resistance thermal converter with the symbol of the nominal static conversion characteristic (NSC) 50M, 100M, 50P, 100P, Pt100, Pt500, Pt1000 or other.
- thermoelectric converter with NSH XA(K), XK(L), PP(S), PR(V), ZK(J) or others;
- converter with a unified output signal of direct current  $0 \div 5 \text{ mA}$ ,  $4 \div 20 \text{ mA}$ ,  $0 \div 20 \text{ mA}$ ,  $0 \div 0.1 \text{ V}$ ,  $0 \div 1 \text{ V}$ ,  $0 \div 10 \text{ V}$  or a pulse signal with an amplitude of  $24 \text{ V} \pm 30 \%$  and a frequency of  $0 \div 10000 \text{ Hz}$  with the ability to set the initial and final values of the indication scale. Dependence: linear or corresponds to the temperature change of the emf of the selected thermocouple (HCX: XA(K), XK(L) or other.)

1.1.5 For the version with current input, the regulator provides a + 24 V output with a maximum current of 20 mA to power the converter with a unified output signal.

1.1.6 Operating conditions:

- ambient air temperature, °C from minus10(40)\* to 50(60)\*
- relative humidity at a temperature of 35 °C not more than 98%
- atmospheric pressure, kPa from 84 to 106.7

**Note.**

\*The values in brackets are for the controller with an extended operating temperature range.

**Additional requirements are imposed on regulators for nuclear power plants:**

- impact resistance 10 g, 10 msec any plane
- vibration resistance group not worse than N2

**1.2 Technical specifications**

1.2.1 Thermal converter NSC (input signal type)*	K, L, S, B, J 50M, 100M, 50P, 100P, Pt100, Pt500, Pt1000
<hr/>	
1.2.2 Number of channels	
<hr/>	
1.2.3 Measuring temperature change range, °C:	
- for NSH type K	from minus 50 to 1250
- for L-type NSH	from minus 50 to 600
- for NSH type B	from 300 to 1600
- for NSH type S	from 0 to 1300
- for NSH type J	from minus 100 to 750
- for NSH type 50M, 100M	from minus 50 to 150
- for NSH type 50P, 100P, Pt100, Pt500, Pt1000	from minus 50 to 600
<hr/>	
1.2.4 Maximum possible indication range for a unified signal	from minus 999 to 9999
<hr/>	
1.2.5 Limit of permissible basic absolute error of the regulator, °C:	
- for NSH type K, L, S, J	±2
- for NSH type B	±3
- for NSH type 50M,100M,50P,100P,Pt100, Pt500, Pt1000	±(1+0.005 TI) or ±(0.5+0.001 TI) or ±(0.1+0.001 TI) or
<hr/>	
1.2.6 Limit of permissible basic combined measurement error of a unified signal, %	±0.25 or ±0.1 or ±0.05



1.2.24 Average service life, not less than, years	10
1.2.25 Probability of failure-free operation for NPPs for 10,000 hours, not less	0,95
1.2.26 Mass, no more than, kg	1
1.2.27 Overall dimensions, mm	Depending on the design variant (see Table1)

1.2.28 Execution

\* The BP-10Ex regulator is used in conjunction with a resistance thermal transducer with NSH Pt1000 and its structure and operation are described in Appendix 10 and the TMIR.421513.115PS passport.

\*\* The BP-10V2A regulator is used in conjunction with the TOP-109-52A resistance thermal converter and its structure and operation are described in Appendix 12 and the TMIR.421513.116PS passport.







**1.3 Completeness**







- Regulator 1 piece
- Operating instructions 1 note per regulator group
  - Passport 1 note
  - For certain options or according to the order, the controller may include a temperature or other physical quantity transducer.

**1.4 Structure and operation**

1.4.1 The appearance of the main designs of the regulator is shown in the table1Additional designs are given in Appendix 1.

**Table 1**

<b>Main designs</b>		
<b>shield BP-10ShCH</b>	<b>shield BP-10ShCH (dual-channel or with timer)</b>	<b>wall-mounted BP-10B</b>
		
72 x 55 x 80 (window dimensions in the shield 67x49)	72 x 55 x 80 (window dimensions in the shield 67x49)	117 x 100 x 60 (90 x 65 x 43)
<b>wall-mounted BP-10B 1</b>	<b>on DIN rail BP-10R</b>	<b>BP-10B-K-100</b>
		
145 x 115 x 60	70 x 90 x 65	110 x 106 x 80

<p><b>wall-mounted BP-10B2 (BP-10B1 in an additional housing)</b></p>	<p><b>explosion-proof BP-10Ex</b></p>	<p><b>BP-10B/BP-10B-K-100 shield version ø60mm/100mm/160mm or other, according to the Customer's specifications)</b></p>
		<p>175 x 128 x 88</p>
<p><b>Wall-mounted BP-10B2A for nuclear power plants</b></p>		
<p><b>without additional housing</b></p>	<p><b>with additional housing</b></p>	<p><b>BP-10B-K-100 with side buttons</b></p>
		
		<p><b>Vertical placing the bar fastening</b></p>
		
		<p><b>Horizontal placing the bar fastening</b></p>

The front panel of the regulator has digital indicators for displaying measured values and service symbols, LEDs for displaying the status of output channels, and buttons for setting the necessary parameters and operating modes of the regulator.

The controller can implement communication with digital systems. Communication with digital systems is carried out via the RS485 serial interface (possibly USB). Communication lines with digital systems are galvanically isolated from other circuits. The controller supports the Modbus protocol. It is possible to build information networks using several controllers. In this case, the identification of each controller in the PC is carried out based on their communication number.

The main material of the regulator housing is plastic: ABS, polycarbonate, etc. The only exception is for explosion-proof versions and for NPPs, in which the housings are metal. Moreover, the front panel of the explosion-proof version is made of thick glass, and for NPPs - of thick polycarbonate (to ensure impact resistance).

In the explosion-proof version, magnetic styluses are used that act on the reed switches built into the housing - like buttons. This option can also be used in the BP-10V-K-100 regulators.

To perform the specified measurement and control functions, the controller must be powered from a stationary power supply. If the controller is powered from an AC power supply, additional backup power from a battery is possible. When powered from a DC source as the main power supply, the controller does not have a backup power supply. However, it is possible (optionally) to supply a low-power battery pack for short-term indication of the measured temperature (without control) in emergency or other conditions.

#### 1.4.2 Controller parameters

In the table 2 The names of the regulator parameters, their symbolic designation on the indicator and the range of values of these parameters are given.

**Table 2**

Parameter name	Symbolic designation	Value range
Regulation law (except for execution for operation with valves)	<b>Func</b>	2000, 2100, P, 10, P, 10, P, 4H, 3, 10, 3, 10, 3, 100
Type of NSH converter (input signal)	<b>tYPE</b>	K, L, S, B, J (respectively K, L, S, B, j) C <sub>in</sub> 50, C100, 50П, 100П, P100 (respectively 50M, 100M, 50P, 100P, Pt100) P500, P1.0 (Pt500 and Pt1000 respectively) 0-Hi, 4-20, FrEc (respectively 0 ÷ 5 mA or 0 ÷ 10, 4 ÷ 20 mA, 0 ÷ 10000 Hz)
Decimal point (comma) position when displaying the converted unified input signal (only for linear dependence between display and unified signal)	<b>Pnt</b>	In the I, II, III or IV category
Upper control value setpoint for three-position control law	<b>okay</b>	Measurement range, with toLo ≤ (toHi - 1)
Lower control value setpoint for three-position control law	<b>toLo</b>	Measurement range, with toLo ≤ (toHi - 1)

Setting the upper limit of the indication range when measuring a unified input signal	<b>t_Hi</b>	-999 ÷ 9999
Setting the lower limit of the indication range when measuring a unified input signal	<b>t_Lo</b>	
Dead zone when adjusting with dampers	<b>C_nc</b>	1 ÷ 100 °C
Control value setting	<b>To</b>	Measurement range
Proportional band in PID control or return zone in on-off control	<b>C_Pr</b>	1 ÷ 255 °C
Hysteresis in three-position regulation	<b>hiSt</b>	1 ÷ 100 °C
Alarm upper value setting	<b>tShi</b>	Measurement range, and tSHi ≥ (tSLo + 1)
Lower alarm setpoint	<b>tSLo</b>	
Pulse signal period in PID control or in manual mode	<b>P_t</b>	1 ÷ 100 c
Setting the power factor value in manual mode or its maximum value in PID control	<b>Out</b>	0 ÷ 100%
Differentiation time constant	<b>Td</b>	0 ÷ 255 c
Integration time constant	<b>Of</b>	0,0 ÷ 99.9 min, and at 0.0 the integral component is turned off
Time for the temperature to reach the control setpoint	<b>SPEd</b>	0 ÷ 255 min
Power factor initial value setting (at temperature ≤ t1)	<b>Out1</b>	0 ÷ 100%
Temperature setpoint at initial power factor	<b>t1</b>	Measurement range, °C
Final power factor setting (at temperature ≥ t2)	<b>Out2</b>	Out1 ÷ 100%
Temperature setpoint at final power factor	<b>t2</b>	From t1 to the upper limit of the measurement range, °C
Timer on/off for adjustment	<b>tim</b>	<b>OnorOFF</b>
Time setting for timer	<b>ЧAC</b>	From 0 hours 0 minutes to 99 hours 59 minutes
Channel number (for multi-channel)	<b>Chan</b>	1, 2 ... N, where N is the number of channels
PC exchange rate, baud	<b>bAud</b>	2400...38400
Communication number	<b>rS_n</b>	0...255

**Note.** It is possible to enter new controller parameters, which are described in Appendix 4.

#### 1.4.3 Regulatory features

The controller can use a timer that operates in one of two modes:

- a) the timer is not tied to the setpoint to, implemented by a separate channel;
- b) the regulator maintains the set value of the measured value for a certain period of time, which is set in the **ЧAC** parameter. The duration of the **ЧAC** interval is counted from the moment the measured value reaches the set value. After this time, the timer value is reset and to start a new regulation process, it is necessary to set a certain value for the timer again.

If the controller does not have a timer or the timer mode is disabled, the controller constantly operates in setpoint maintenance mode.

The regulatory laws are described below.

#### 1.4.3.1 Two-position regulation

a) "zoom" mode (symbolic designation on the indicator: Func→ 2 \_ □)

Measured size	$T \leq to - C_{Pr}$	$to - C_{Pr} < T < to$	$T \geq to$
Channel number			
Channel 1 (adjustment)	Enabled	Saving the previous state	Disabled
Channel 2 (alarm)	Enabled at $T \leq tSLo$ and $T \geq tShi$ , the switch-off occurs with a delay of the value that is the price of the smallest digit		

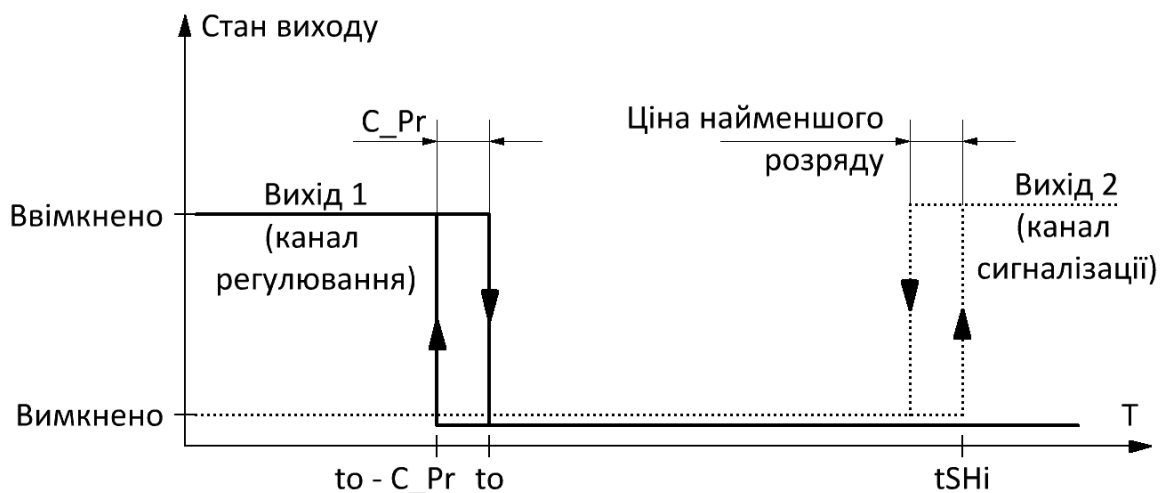

b) "reduction" mode (symbolic designation: Func→ 2 \_ □)

Measured size	$T \leq to$	$to < T < to + C_{Pr}$	$T \geq to + C_{Pr}$
Channel number			
Channel 1 (adjustment)	Disabled	Saving the previous state	Enabled
Channel 2 (alarm)	Enabled at $T \leq tSLo$ and $T \geq tShi$ , the switch-off occurs with a delay of the value that is the price of the smallest digit		

**Note.** To eliminate the influence of one of the alarm settings, it must be set to its extreme value (for example,  $tSLo$  to minimum,  $tShi$  to maximum).

1.4.3.2 Three-position control (for a single-channel controller). Implemented in two-position control mode using channel 2 for the second control actuator.

a) "increase - decrease" mode. In the menu, select the two-position "increase" (Func→ 2 \_ □), the  $tSLo$  setting is set to minimum, and the operating setting for channel 2 becomes  $tShi$ .

b) "increase - increase" mode

It differs from "increase-decrease" in that the  $tShi$  value is chosen as maximum, and the operating setting for channel 2 becomes  $tSLo$ .

c) "reduction - decrease"

It differs from "increase - decrease" in that for channel 1 a two-position "decrease" is selected (Func→ 2 \_ □).

**Note.** A possible controller option is when the three-position control law is selected from the menu (3\_□□, 3\_□□, 3\_□□).

Then:

a) "increase - decrease" mode (symbolic designation 3\_□□)

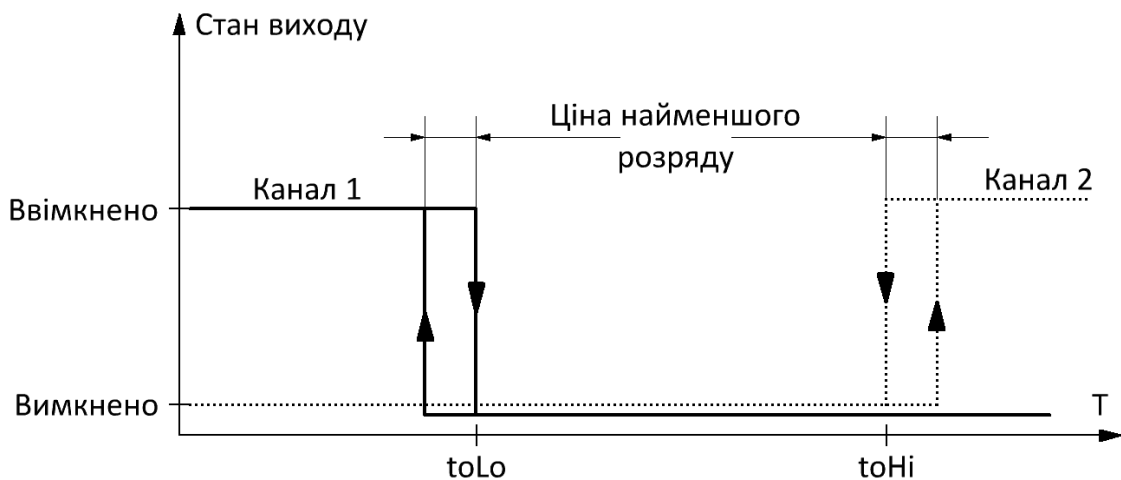

b) "increase - increase" mode (symbolic designation 3\_□□).

Differs from the "increase - decrease" mode in that channel 2 is inverted

c) "reduction - reduction" mode (symbolic designation 3\_□□)

differs from the "increase - decrease" mode in that channel 1 is inverted.

#### 1.4.3.3 PID control

The regulation is carried out by pulse-width modulation of its output signal (if there is a switching output) or by changing the value of the unified signal (if there is an analog output). The duration of the on state during the period  $P\_t$  of the pulse signal or the value of the unified signal depends on the deviation of the measured value  $T$  relative to the set  $to$  and the PID control parameters: the proportionality range  $C\_Pr$ , the differentiation time constants  $td$  and integration  $ti$ .

The mathematical description of the PID regulation law is given in DSTU 3462-1996.

The regulator implements two cases of the PID regulation law: PID "increase" and PID "decrease" (symbolic designation:  $Pid^{\square}$  i  $Pid_{\square}$ ).

When PID "increases" ("decreases"), the power averaged over the period  $P\_t$ , supplied to the control object, will be maximum at  $T \leq to - C\_Pr$  ( $T \geq to + C\_Pr$ ) and decreases in the proportional range when approaching the setpoint  $to$ . To limit the maximum power, the value of the coefficient  $Out$  can be chosen to be different from 100%.

#### 1.4.3.4 Partial cases of PID regulation

A partial case of PID control is proportional (P), proportional-integral (PI), proportional-differential (PD) control laws. To exclude the corresponding control component: differential for PI, integral for PD and both for P control law, it is necessary to select the parameter  $td=0$  or (and)  $ti=00.0$ .

#### 1.4.3.5 Time for the temperature to reach the control setpoint

The change in the control setpoint value over time (according to a linear law), provided that the  $SPEd$  parameter  $> 0$ , is shown in the graph:

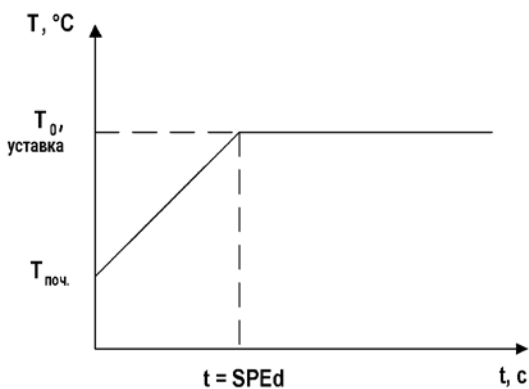

$$T_0(t) = T_{start} + \frac{T_0 - T_{start}}{SPEd} \cdot t \text{ for } t = 0 \div SPEd$$

$$T_0(t) = T_0 \text{ for } t \geq SPEd$$

#### 1.4.3.5 Output power control in PID control

To improve the quality of the PID law, the regulator provides for changing the power factor depending on the measured value:

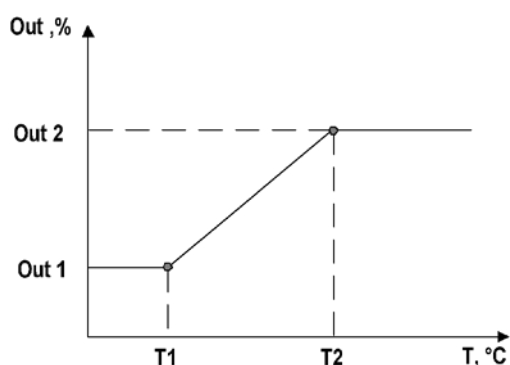

$$Out(T) = Out1 + \frac{Out2 - Out1}{T2 - T1} \cdot (T - T1), \text{ for } T1 < T < T2 ;$$

$$Out(T) = Out1 \text{ for } T < T1 ;$$

$$Out(T) = Out2 \text{ for } T > T2 ;$$

#### 1.4.3.7 Adjustment by valves (if available)

It differs from PID control according to clause 1.4.3.3 in that two outputs are implemented on channel 1, one of which works as a PID “increase”, and the other as a PID “decrease”. In addition, a dead zone is introduced, which is located symmetrically with respect to  $t_0$ , within the range from  $t_0 - C_{nc}$  to  $t_0 + C_{nc}$ .

#### 1.4.3.8 Manual control mode (Func = MANUAL)

In this mode, you can set the value of the power factor Out (in % of the maximum) and the repetition period of the pulse signal  $P\_t$ .

#### 1.4.4 Indication features when measuring a unified signal

1.4.4.1 Features of the indication of the measured quantity, which linearly depends on the unified input signal.

In a regulator with inputs for unified signals, the lower and upper limits of the indication range can be set using the keyboard. In this case, the position of the decimal point (comma) should also be taken into account. For example, for a unified signal of 4-20 mA, which corresponds to a pressure indication of 0.00-10.00 MPa, the settings will be as follows: position of the decimal point Pnt in the 3rd digit;  $t_{Hi} = 10.00$ ,  $t_{Lo} = 0.00$ . The dependence between the input and the indicated signal is linear.

1.4.4.2 Features of the indication of the measured quantity that nonlinearly depends on the unified input signal.

This version of the controller is used for compatible operation with measuring transducers in which the unified output signal does not have a linear dependence on the measured value. This mainly applies to cheap measuring transducers working with thermocouples (for example, with NSCs of the XA(K), XK(L) type, etc.), in which the dependence between their output signal and temperature is nonlinear. For this version, the Pnt parameter may be absent in the controller menu, and the  $t_{Hi}$  and  $t_{Lo}$  settings determine the range of measured temperatures.

#### 1.4.4.3 Alarm features

In the variant using signaling, the channel is turned on at  $T \leq t_{SLo}$  and  $T \geq t_{SHi}$ , and the

switch-off occurs with a delay of the smallest discharge value.

Alarms can only be implemented in a single-channel controller.

## **1.5 Marking and sealing**

1.5.1 The following is written on the nameplate located on the rear (side) of the regulator:

- trademark of the manufacturer (can only be applied to the front panel of the regulator);
- regulator type;
- NSH of the converter (input signals);
- maximum measurement range (if necessary);
- power consumption;
- supply voltage and frequency;
- year of manufacture and serial number of the regulator according to the numbering system of the manufacturing company (may be combined in the number);
- the version for NPP contains index A;
- for BP-10Ex, explosion protection marking, etc.

1.5.2 The regulator is sealed with a plastic seal at the screw connection of the regulator and/or additional protective housing or with a self-adhesive seal. The wall-mounted regulator and/or additional protective housing is sealed at the customer's facility by the organization that carries out installation and commissioning work.

Note. Marking of the NSH converter, voltage and frequency of the regulator supply in wall-mounted version and/or with additional protective housing (Appendix 7) is carried out on the input cables or the inside of the protective housing by the organization that carries out installation and commissioning work at the customer's facility. If necessary, self-adhesive seals and self-adhesive marking are provided by the regulator manufacturer.

## **2. Intended use**

### **2.1 Safety instructions**

2.1.1 Before connecting the regulator to the mains, check the power cord for possible insulation damage.

2.1.2 Start-up and adjustment of the regulator should only be carried out by personnel who have been instructed in safety procedures.

2.1.3 It is strictly forbidden to make external connections or disconnections without removing all voltages applied to the regulator.

2.1.4 In the event of emergency conditions and operating modes, the regulator must be immediately disconnected.

### **2.2 Operational limitations:**

- the regulator supply voltage must not exceed the permissible limits;
- the power at the regulator output must not exceed the permissible value;
- The ambient air temperature should not exceed 60°C.

### **2.3 Preparation for work**

The procedure for preparing for work is as follows:

- carry out installation - installation of the regulator;
- connect the primary converter and actuators to the regulator in accordance with the external connection diagram (Fig. 1, a for resistance thermal converters and thermoelectric converters; Fig. 1, b for converters with a unified output signal; Fig. 1, c for

dual-channel regulators; Fig. 1, d - connecting the regulator to the RS485 network). For a regulator with one input on the connector and one powerful output, the external connection diagram or fragments thereof can be applied on the rear panel of the regulator;

- connect the regulator to the power supply;
- if there is a two-wire communication line with a resistance thermal converter, if necessary, adjust the beginning of the measurement range (section 2.4.3):
- if necessary, connect communication lines to any other microprocessor control and alarm systems.

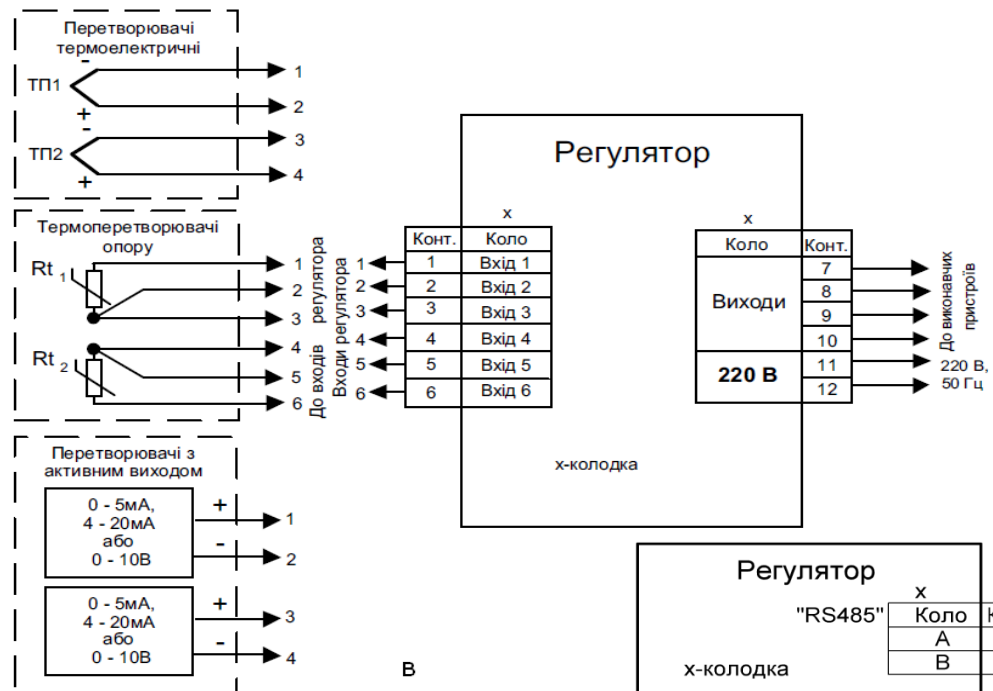
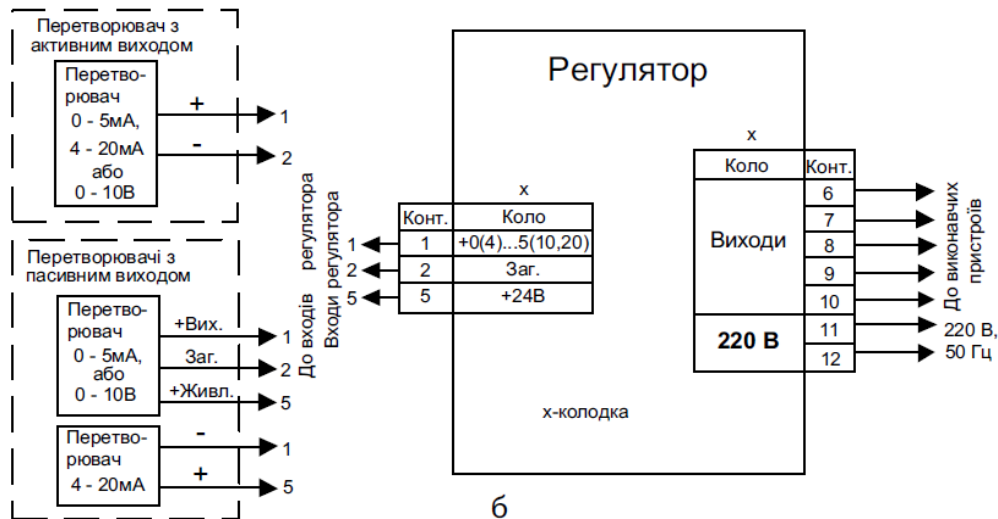
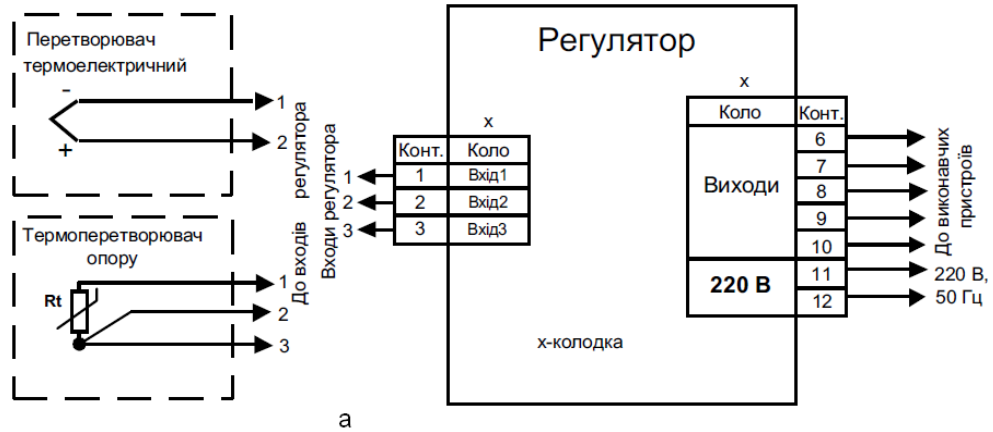

**Note.** For a two-wire communication line with a resistance thermal transducer, Input 3 of the regulator is not used, but if the terminal itself is present, it is necessary to short Input 2 and Input 3 together.

For The explosion-proof and nuclear power plant versions of the controller are supplied with a thermal converter connected to it. Other circuits can also be connected using cables.

## 2.4 Procedure

After connecting the regulator to the power supply, its components are tested. After the test is completed, the regulator switches to the intended operating mode. At the same time, the measured values are displayed.

### **Note.**

1. When the measured value exceeds its upper value, the symbol “— — — —” is displayed on the indicator and the output channels of the regulator are turned off.

2. When the measured value exceeds its lower value, the symbol “\_ \_ \_ \_” is displayed on the indicator and the output channels of the regulator are turned off.

Using the keyboard buttons, you can change the controller parameters.

### 2.4.1 Changing the control setpoint

Called by pressing a button ▲ or ▼ when displaying the measured value. After that, the designation of the setpoint to is displayed, and then its value. In the multi-channel controller, the designation of the channel ChAn, its number (1 ... N) and the value of the setpoint to are displayed. The channel number and the value of the setpoints can be changed using the buttons, wait 3 seconds and after the inscription Good appears, the new value will be written to the controller's memory.

### **Note.**

1. In manual control mode (Func = MANUAL), after pressing the button, the value of the power factor Out is displayed on the indicator, which can be changed using the buttons.

2. If the timer is on, after setting to (Out in manual mode), you can change (set) the time for the timer.

### 2.4.2 Changing other controller parameter values

It is called by simultaneously pressing two buttons and holding them for 6 seconds when the measured value is displayed. After that, the symbolic designation of the parameter and its value are displayed alternately (table2). The multi-channel controller displays the inscriptions inP, ChAn and the channel number (1 ... N) that must be selected. After that, the symbolic designation of the parameter and its value are displayed in turn (table.2). Use the buttons to change the channel number and parameter value as needed.

The transition to the next parameter is carried out by not pressing the buttons for three seconds. The new parameters of the regulator are written to its internal memory after the Good inscription appears.

### 2.4.3 Changing hidden settings

Changing the hidden parameters of the controller is implemented as follows:

- turn off the power;
- Turn on the power while pressing two buttons simultaneously and dial the access code.

After the COEF inscription appears, the values of the coefficients responsible for the metrological parameters of the regulator are displayed on the indicator in turn (≈3 seconds), which can be adjusted using the buttons.

Hidden parameters include corrections of the measuring circuits of the regulator (offset, transfer coefficient, corrections for the non-ideality of the temperature compensation circuits of the free ends of the thermocouple, etc.) and the price of the smallest discharge when

using resistance thermal converters. These parameters are set by the manufacturer and it is undesirable to change them so as not to violate the metrological characteristics of the regulator. However, at the request of the customer, the manufacturer can provide advice on the method of changing the characteristics of the regulator.

### 2.5 Operation of the regulator is compatible with a PC.

When the controller and PC work together, the Modbus protocol of the RS485 serial interface is supported. The program for interaction between the controller and the PC is recorded on a disk, which is included in the delivery set (when ordered). The program allows exchange with the PC of up to 256 controllers with communication numbers from 0 to 255. The controllers are connected to the network by paralleling the same-named outputs.

### 2.6 Possible problems and how to fix them

No power indication	- check for voltage
The control or alarm actuators do not turn on when the channels are indicated by LEDs.	- check the integrity of the communication line between the regulator output and the actuators
The indicator shows the symbol “_ _ _ _” or “_ _ _ _”	- check the integrity of the converter or the communication line between it
The indicator shows the symbol StEr	- enter the correct adjustment parameters

## 3. Maintenance

3.1 Maintenance of the regulator is reduced to carrying out preventive work during operation, following the operating rules set out in this manual, and periodic monitoring of the metrological characteristics (MCC) of the regulator.

3.2 Preventive work is carried out at least once a year by persons who directly operate the regulator, and is reduced to its external inspection. The external inspection is carried out with the power supply turned off and includes checking the regulator fastening, connecting cables, the condition of the contacts, and the absence of mechanical damage.

## 4. KMH Methodology

This section establishes the procedure for conducting periodic CMC of regulators. The recommended interval between CMC is 2 years.

### 4.1 KMH Operations

4.1.1 When conducting CMC, the operations specified in the table must be performed.

**Table 3**

Operation name	Item number methods KMH	Performing operations at KMH	
		primary	periodic
1. External inspection	4.5.1	So	So
2. Checking the electrical strength of the insulation	4.5.2	So	no
3. Checking the electrical insulation resistance	4.5.3	So	So
4. Checking the indication of operating modes, setting settings and functioning of the regulator	4.5.4	So	So

5. Control of the basic measurement error	4.5.5	So	So
6. Checking the control and alarm parameters	4.5.6	So	So

#### 4.2 KMH tools

4.2.1 When conducting **CMC**, the means specified in the table must be used<sup>4</sup>

#### 4.3 Safety requirements

When conducting KMH, the "Rules for the Technical Operation of Consumer Electrical Installations" approved by the Ministry of Fuel and Energy of Ukraine (Order No. 258 of July 25, 2016) and the "Rules for the Safe Operation of Consumer Electrical Installations" approved by the State Supervision Service for Labor Protection (Order No. 4 of February 10, 1998), the requirements of 12.2.007-0-15 and the safety rules specified in the operational documentation for KMH facilities must be followed.

#### 4.4 Conditions of KMH and preparation for it

4.4.1 When conducting CMC, the following conditions must be met:

- ambient air temperature (20 ± 5)°C
- relative humidity 30 ... 80%;
- atmospheric pressure 84 ... 106 kPa;
- mains voltage (220<sup>+22</sup><sub>-33</sub>) IN;
- power supply frequency (50 ± 1) Hz;
- absence of external electric and magnetic fields (except for the Earth's);
- no vibration, shaking, or shock.

**Table 4**

Item number regarding the <b>CMX</b> methodology	KMH tools and their regulatory and technical characteristics
4.5.2	Universal breakdown installation UPU-1M. Voltage change range up to 10 kV sinusoidal shape with a frequency of 50 Hz, power 0.25 kVA, voltage error no more than ±5% .
4.5.3	Megaohmmeter M4100/3, TU 25-04.2131-78. Measurement range 0 - 100 MΩ, output voltage 500 V.
4.5.4, 4.5.5, 4.5.6	<p>Voltage comparator P3003, GOST 9245-79, measurement range from 0 to 1.111110 V, accuracy class 0.0005;</p> <p>resistance magazine R4831, TU 25-04.3919-80, measurement range from 0 to 10,000 Ohm, accuracy class 0.02;</p> <p>DC voltage source B5-45, GOST 18953-73, output voltage range from 0 to 50 V;</p> <p>DC voltmeter Shch-31, GOST 14014-91, measurement range from 0 to 100 V, accuracy class 0.005/0.001;</p> <p>zero thermostat type TN-114 for reproducing the melting temperature of ice with an error of no more than ±0.03 °C;</p> <p>glass mercury thermometer TL-4, TU 25-2021.003-88, measurement range from 0 to 55 °C with a division value of 0.1 °C;</p> <p>pulse generator G5-60;</p> <p>resistance measuring coil P321 10 Ohm II category;</p> <p>working standard of II category TEP-115;</p> <p>liquid thermostats series TSR-0105 from -40 to 250<sup>About</sup>C;</p>

**Note.** The use of other CMC means with characteristics that are not inferior to those given above is allowed.

4.4.2. All measuring equipment must be calibrated or subjected to metrological certification.

#### 4.5. Conducting the CMC

##### 4.5.1. External inspection

During external inspection, it is necessary to establish:

- absence of gross mechanical damage;
- integrity of connecting cables;
- having a passport with a TC mark.

##### 4.5.2 Checking the electrical strength of the insulation

Before testing, it is necessary to short-circuit the contacts of the galvanically separated circuits with each other. Apply the test voltage of the breakdown installation between the short-circuited contacts and the power terminals from the AC network, increase it slowly, starting from zero to 1500 V for about 30 s. Keep the regulator under the test voltage for 1 min. Then reduce the voltage to zero and turn off the installation. Similarly, apply a test voltage of 1500 V between the short-circuited contacts of each output and other circuits.

The result of the test operation is considered positive if no signs of breakdown or surface overlap of the insulation were observed when the test voltage was applied.

**Note.** When using the regulator in a set with a thermal converter, the test voltage is applied between the thermoconverter armature and the rest of the galvanically separated regulator circuits. It is allowed to separately test the thermoconverter for electrical insulation strength according to the TD for the thermoconverter.

##### 4.5.3 Checking the electrical insulation resistance

Connect a megohmmeter with a rated voltage of 500 V between the regulator terminals, as in section 4.5.2. The megohmmeter readings should be taken 1 minute after applying its voltage to the regulator terminals.

The result of the test operation is considered positive if the electrical insulation resistance exceeds 20 M $\Omega$ .

**Note.** When using the regulator in a set with a thermal converter, the insulation resistance is also measured between the thermoconverter armature and the rest of the galvanically isolated circuits of the regulator. It is allowed to separately measure the electrical insulation resistance of the thermoconverter. In the absence of regulated characteristics for the thermoconverter, the insulation resistance of its galvanically isolated parts is measured with a megohmmeter with a rated voltage of 1000 V. In this case, the insulation resistance must be at least 100 M $\Omega$ .

##### 4.5.4 Checking the indication of operating modes, setting settings and functioning of the regulator

This CMX operation includes checking all the controller capabilities described in section 2.4. The check is performed with the converter or its simulator connected, as in section 4.5.5.

The result of the verification operation is considered positive if the capabilities described in clause 2.4 are fully implemented using the keyboard and display.

##### 4.5.5 Control of the basic measurement error.

The measurement error of the set is defined as the difference between the temperatures measured by the measuring device and the working standard and must not exceed the total error of the measuring device and the temperature converter according to this manual and the temperature converter according to DSTU for the type and class of the temperature converter used.

The basic measurement error control scheme coincides with the external connection scheme (Fig. 2), with the exception of the primary converter, which is replaced by its simulator (resistance store for thermal resistance converters, voltage comparator for thermoelectric converters and DC voltage sensors, series-connected power supply and resistance store for DC sensors, pulse generator for frequency sensors). The Appendix provides an example of the implementation of simulators of thermoelectric converters and DC sensors.

The controller preheating lasts 15 minutes.

The basic error is controlled at three points: at the beginning, in the middle and at the end of the measurement range.

The values of the input simulated quantity corresponding to these range points are taken from DSTU IEC 60671:2012, DSTU 2858:2015 for resistance thermal transducers, DSTU EN 60584-1:2016 for thermoelectric transducers and with conversion characteristics for transducers with a unified output signal.

The basic absolute measurement error is defined as the difference between the measured and the specified (simulated) value of temperature or other physical quantity.

To determine the basic combined error (if necessary), the basic absolute error value must be divided by the measurement range and multiplied by 100%.

The determination of the basic measurement error should be carried out for all types of applied NSC (input signals).

The basic measurement error should not exceed the limits specified in clause 1.2.4 or 1.2.5.

**Note.** When using the regulator in a set with a thermal converter, the basic error is checked at no less than three points of the measurement range (at the beginning, in the middle and at the end of the measurement range) for primary CMC, and at two points (at the beginning and at the end of the measurement range) for periodic CMC. For this, the thermal converter of the regulator is installed in the thermostat together with the working temperature standard and joint measurements are carried out.

#### 4.5.6 Checking control and alarm parameters

The verification scheme coincides with the scheme described in section 4.5.5. Using the keyboard, set the upper and lower setpoints of the two-position regulation (one for each type of NSH).

A smooth change in the simulator signal results in a change in the state of channel 1 of the output (the output state is checked with a tester), which is accompanied by a change in the LED glow. The value of the measured value at which the output state changes is recorded and compared with the value of the specified setpoint. The difference between them should not exceed the value of the lowest digit.

Similarly, the alarm mode is checked (if channel 2 is available).

## 5. Current repairs

Regulators are non-renewable at the place of operation, but are recoverable and repairable in the conditions of the manufacturing enterprise.

## 6. Storage

Storage is carried out in closed, ventilated rooms at a temperature of 5 to 40 °C and a relative humidity of up to 80% (at a temperature of 25 °C). The air should not contain harmful impurities that cause corrosion.

## 7. Transportation

7.1 Regulators are transported in the manufacturer's packaging by all types of closed transport, including aircraft in sealed heated compartments at temperatures from minus 50 to 50°C and relative humidity up to 100% at a temperature of 25°C.

7.2 During loading and unloading operations and transportation, regulators must not be subjected to sharp impacts and exposure to atmospheric precipitation.

The method of loading on the vehicle must exclude movement of regulators packed in transport containers.

## 8. Disposal

The materials from which the regulators are made are not harmful to human life and health and do not pollute the environment.

After the end of the service and storage period, the regulators must be dismantled from the facility in accordance with the established procedure.

## 9. Certificate of acceptance

The BP-10 flow meter-regulator, part number \_\_\_\_\_, complies with DSTU 3462-96 ( EN 60730-1:2019, ДСТУ EN 61010-1:2014 ), this manual and the passport and is suitable for operation.

Date of manufacture \_\_\_\_\_

The reception was conducted by \_\_\_\_\_

M.P.

## 10. Manufacturer's warranties

10.1 The manufacturer guarantees that the regulator complies with the specifications of this manual for 24 months from the date of delivery, subject to compliance with operating and storage conditions.

10.2 Warranty shelf life - 12 months from the date of manufacture.

## 11. Information about the holding of the KMH

Date KMH	KMH results	Position, surname, signature of the person who conducted the CMC	Note

*Address of the manufacturing company:*

*LLC "Termomir"*

*Khutorivka St., 40A, office 230*

*Lviv, 79070*

*(050) 37165 18*

*[thermomir@ukr.net](mailto:thermomir@ukr.net)*

*[www.thermomir.com.ua](http://www.thermomir.com.ua)*

# Appendix 1

## Appearance of additional designs of BP-10 measuring regulators

Wall-mounted

**BP-10BM1**



**BP-10BM2**



**BP-10L1**



**BP-10L2**



Desktop

**BP-10L**



80x155x192

**Insertion unit BP-10B**  
side view



60 x 80 x 20

Insertable

## Appendix 2

### Scheme of implementation of some converter simulators for controlling the basic measurement error of the regulator

a) thermoelectric converter simulator diagram

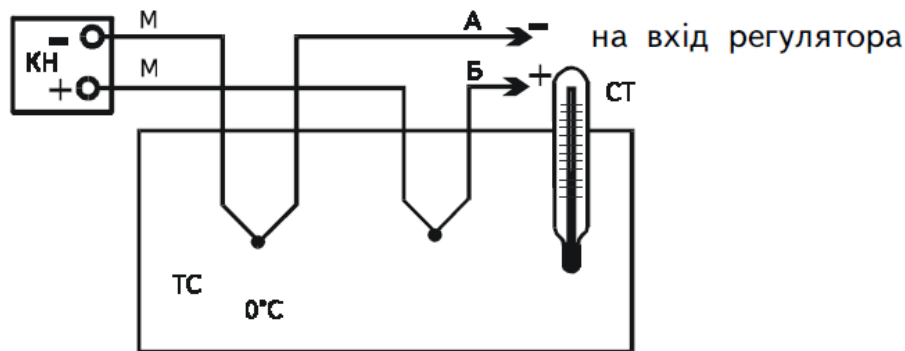

**Note.** For thermoelectric converters with NSH type B, the TC thermostat and compensation wires A and B are absent, and the KN is connected directly to the regulator.

b) diagram of a converter simulator with a unified DC output signal

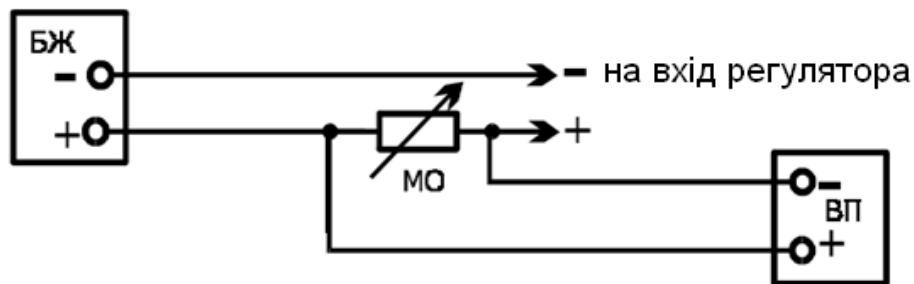

KN – voltage comparator R3003; BZH – power supply B5-45; VP – measuring device Shch31; MO – resistance magazine R4831; ST – glass mercury thermometer TL-4; TS – zero thermostat (use of a passive thermostat - a vessel with a volume of > 5 dm is allowed<sup>3</sup>, in which insulating material (for example, aluminum oxide powder) is poured and the free ends of the compensating thermoelectrode wire and the TL-4 mercury thermometer are placed, while the value of the specified input signal  $E_{vx}$  is required behind reduce by the value of the thermal emf of the free ends of the thermoelectrode wire according to GOST 3044-1994 (DSTU 2837-1994); M - copper conductors; A - negative potential conductor, B - positive potential conductor of the compensating thermoelectrode wire, which is selected depending on the type of thermoelectric converter.

For regulators that work in conjunction with DC sensors, the setpoint input current is determined by the formula

$$I_{vh_{behind}} = \frac{IN_{VP}}{R_{WE}},$$

where  $U_{vp}$  is the voltage measured by the VP;  $R_{mo}$  is the resistance of the resistance store.

## Appendix 3

### PID controller parameter selection (optimization)

In temperature control problems, the most common are two-position control and proportional-integral-derivative (PID) control.

Two-position control ensures that an actuator (e.g. a heater) is turned on or off depending on whether the measured parameter is lower or higher than the set level.

With two-position regulation, there are fluctuations of a technological nature in the system, and their magnitude is determined only by the system parameters (inertia of sensors, inertia of actuators, etc.) and is almost independent of the regulator.

In PID control, the control signal depends on the difference between the measured and setpoint values, on the integral of the difference, and on the rate of change of the parameters. As a result, the PID controller ensures that the actuator is in a state in which the measured parameter is equal to the setpoint.

The control signal for a PID controller is determined by three components:

$$U = C_{pr}(T - T_o) + \int (T - T_o) \frac{dt}{of} + td \frac{d(T - T_o)}{dt}$$

$(P$  is the proportional component)

$(I$  is the integral component)

$T_o$  – set temperature

$T$  – measured temperature

$C_{pr}$  – proportionality zone

$of$  – integration time

$td$  – differentiation time

It is proposed to set up the regulator experimentally in 3 stages:

- 1 – determination of the required proportionality zone,
- 2 – determination of the differentiation time,
- 3 – determination of integration time.

#### Stage 1. Determining the required proportionality zone

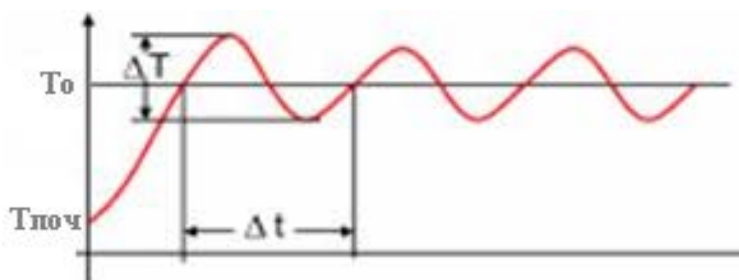

**Fig. 1**

recorded (Fig. 1).

$T_{initial}$  – initial temperature in the system

$T_o$  – that is the set temperature.

$\Delta T$  – range of temperature fluctuations

$\Delta t$  – period of temperature fluctuations

Before setting the proportional band, the integral and differential components are switched off, or the integration time is set to the maximum possible, and the differentiation time is set to the minimum possible. The proportional band value  $C_{pr}$  is set to zero. In this case, the controller performs the function of a two-position controller. The transient characteristic is

Set the proportionality zone equal to the temperature range  $C_{pr} = \Delta T$ . This value is a first approximation for the proportionality zone. It is necessary to analyze the transient response again.

Possible variants of the transient response are shown in Fig. 2.

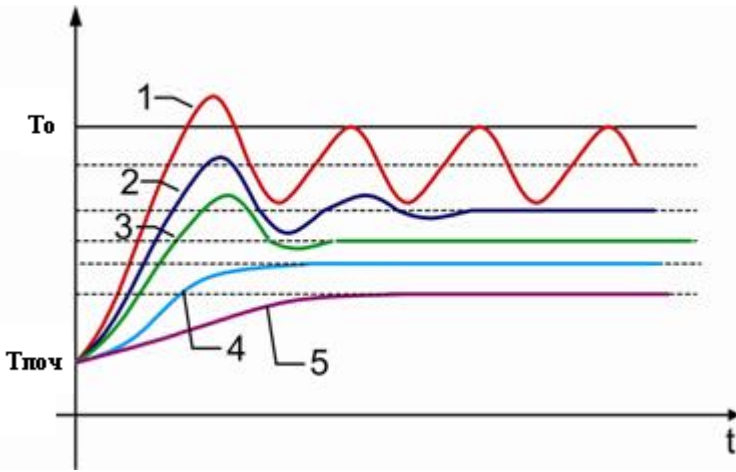

Fig. 2

*Type 1 transient response.* The proportional band value is too small. The transient response (and therefore the controller settings) are far from optimal. The proportional band should be significantly increased.

*Type 2 transient response.* damped oscillations of (5-6) periods are observed in the transient characteristic. If the differential component of the PID controller will be used in the future, then the selected value of the proportional band is optimal. If the differential component of the PID controller will not be used in the future, then it is proposed

to increase the proportional band in such a way as to obtain a transient characteristic of 3 or 4.

*Type 3 transient response.* The transient characteristic shows a small outburst and rapidly decaying oscillations (1-2 periods). This type of transient characteristic provides good performance and a quick return to the set temperature. In most cases, it can be considered optimal if the system allows outbursts (overheating).

*Type 4 transient response.* The temperature smoothly approaches the set value without emissions and oscillations. This type of transient response can also be considered optimal, but the speed of the regulator is underestimated.

*Type 5 transient response* A very slow approach to the set value indicates that the proportionality zone is too large.

Two things should be noted. First, in all the cases considered, the set temperature value does not coincide with the temperature setpoint  $T_0$ . The larger the proportional band, the greater this difference. Second, the longer the duration of transients, the larger the proportional band. Thus, the proportional band should be chosen as small as possible. Finally, the difference between the set temperature and the temperature setpoint is removed using the integral component of the controller.

## Stage 2. Determination of differentiation time

This step is only used when a full-featured PID controller is used. If the differential component is not used (a proportional-integral (PI) controller is used), then proceed to step 3.

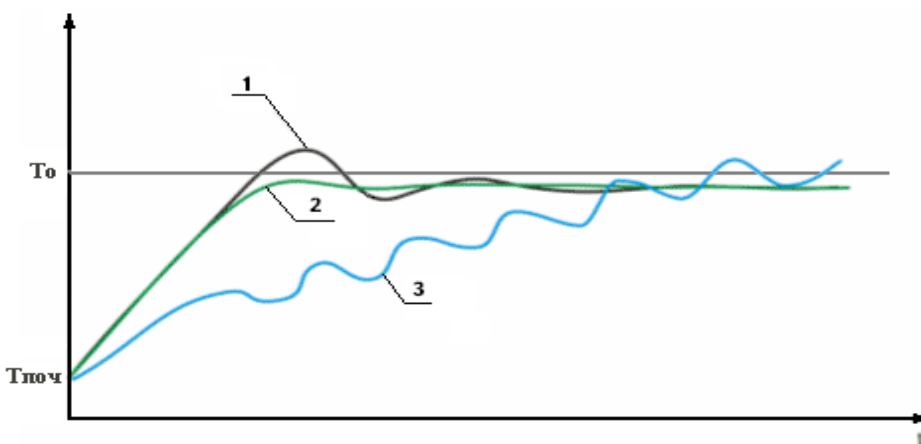

Fig. 3

At the stage of determining the required proportionality zone, a zone corresponding to a transient characteristic of type 2, in which damped oscillations are present (curve 2 in Fig. 2), is established. The differentiation time should be set so that the transient

characteristic looks like curve 2 in Fig. 3.

As a first approximate value of the differentiation time,  $t_d=0.2\Delta t$  can be chosen. Reducing  $t_d$  reduces the effectiveness of the differential component (curve 1, Fig. 3). Increasing  $t_d$  reduces the

emissions created by the proportional component, but if the optimal value is exceeded, it can lead to the creation of natural oscillations (curve 3, Fig. 3).

### Stage 3. Determination of integration time

By selecting  $t_i$ , a transient characteristic close to curve 3 in Fig. 4 can be achieved. Reducing  $t_i$  leads to a faster achievement of the setpoint, but at the same time, emissions on the transient characteristic increase (curve 2, Fig. 4). And when  $t_i$  is reduced below the critical level, undamped oscillations occur (curve 1, Fig. 4). Increasing  $t_i$  reduces emissions on the transient characteristic, but increases the time to reach the setpoint. You can start selecting the value of  $t_i$  from a time equal to  $\Delta t$ .

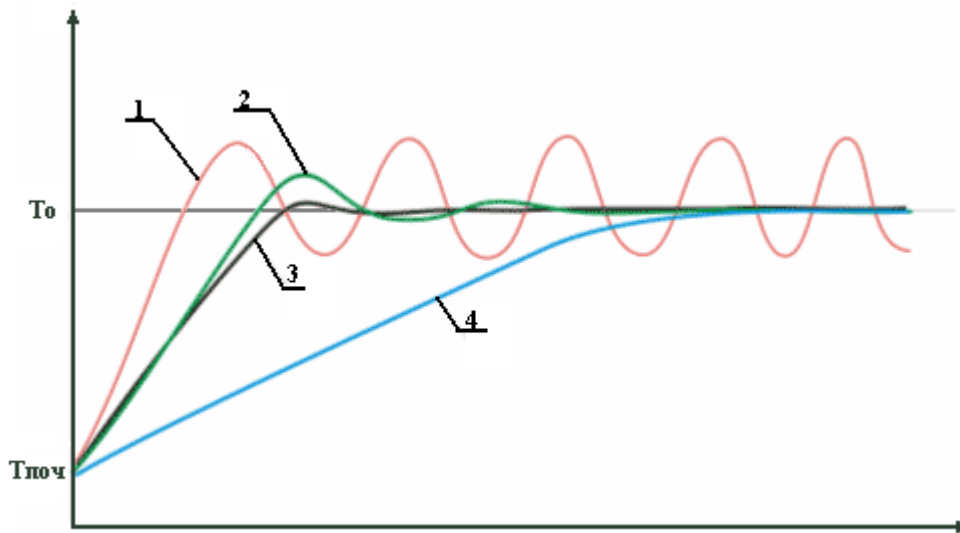

Fig. 4

## Appendix 4

### Additional parameters for two- or three-channel controller

#### **Changing the control setpoint**

Called by pressing a button ▲ when displaying the measured value. The indicator shows the channel number (Ch1, Ch2 or Ch3 (for three-channel regulator)), then the setpoint value to. You can change the channel and setpoint value using the buttons, wait three seconds. After the God inscription appears, the new value will be written to the controller's memory.

#### **Stopping the temperature display on one of the channels**

Done at the push of a button ▼ when displaying the measured value on the required channel.

Returning to the display mode of the measured value of all channels is done by pressing the button again. ▽

#### **Changing other controller parameter values**

It is called by simultaneously pressing two buttons and holding them for six seconds when the measured value is displayed until the InP inscription appears on the indicators. After that, you can select the required channel (by pressing the buttons). Then the symbolic designation of the parameter and its value are displayed in turn (table 1). The necessary change of the parameter value is made using the buttons. The transition to the next parameter is made by not pressing the buttons for three seconds. After the God inscription appears, the new value will be written to the controller memory.

## Appendix 5

### How the timer regulator works

The regulator has an additional button (hereinafter referred to as button 3), which is connected via the corresponding contacts of the regulator connector.

The digital display consists of two parts: the red indicators display the current measured temperature, the green indicators display the timer status or the time until the end of regulation. The red LED (single) displays the output status, the green LED (single) displays the timer on/off.

Changing the control settings (temperature and time) is carried out according to section 2.4.1 and changing other values of the controller parameters is carried out according to section 2.4.2.

The digital display shows the measured temperature and "of" if the timer mode is off (the timer is not used) or "TIME" (the timer setpoint in minutes) if the timer mode is on. The current settings are the same as in the previous session.

The regulator maintains the temperature value according to one of the specified regulation laws and additionally a timer can be used, which is tied to the temperature and the setpoint to. When the temperature of the setpoint to  $\pm 0.5^{\circ}\text{C}$  is reached, a sound signal sounds for  $\sim 1\text{s}$  and the timer countdown begins.

The timer is controlled using the "TIME" parameter. The "TIME" parameter is the timer time setting in minutes ( $0 \div 999$  min). In order to turn off the timer mode, it is necessary to set (according to p. 2.4.1. note 2) the "TIME" parameter value to zero ("TIME" = 0). Then the green indicators will show the inscription "of" – the timer is turned off.

#### **Working with the timer**

When the timer mode is enabled ("TIME" > 0), but the timer has not yet started or has already run out of time, the green indicators show the set timer setting value ("TIME" parameter). Output 2 is closed, the green LED is on.

The timer is started by pressing button 3. At the same time: the green LED goes out - output 2 opens, the decimal point in the lowest digit lights up. When the temperature reaches the setpoint to  $\pm 0.5^{\circ}\text{C}$ , the countdown begins, which is displayed on the green indicators, the decimal point in the lowest digit flashes and a short sound signal sounds (duration  $\sim 1\text{s}$ ).

After the specified time (parameter "TIME") has elapsed, regulation stops, the green indicators light up with the specified timer setting value (parameter "TIME"), output 2 closes, the green LED lights up and a sound signal sounds for  $\sim 5$  seconds.

The timer can be restarted (adjusted) by pressing button 3. The timer can also be stopped by pressing button 3.

## Appendix 6

### Using the BP-10B2 regulator to replace the TKP-160Sg

In the BP-10V2, output 1 (regulation) implements the function of turning on/off the power transformer's blower, and output 2 generates an alarm when the limit temperature is reached.

The display of the BP-10V2 regulator indicates the current temperature. The left (red) LED 1 shows the status of output 1 (regulation), the right (green) 2 - the status of output 2 (alarm).

The regulation law is two-pronged.

The control parameter is the t0 setpoint. The reversal zone during control is implemented by the C\_Pr parameter. The limit temperature alarm setpoint is implemented by the tShi parameter (the upper alarm setpoint for the controller). The reversal zone with this setpoint corresponds to the value of the lowest digit.

The t0 setting is called by pressing one of the buttons, after which t0 appears on the indicator, followed by the setting value, which is changed by the buttons (left - decrease, right - increase).

After pressing both buttons for a few seconds, the TYPE parameter (temperature transducer NSC) appears on the display. When using a temperature transducer with NSC Pt1000, the value P1.0 is set. After that, the Func parameter (control law) appears, which is set to 2\_\_u (in our case, 2-position reduction or cooling).

Next, the parameter t0 appears, which is already set, followed by C\_Pr (the return zone, the value of which is changed using the decrease and increase buttons).

The next parameter is tShi (upper alarm setpoint, corresponding to the limit temperature, which is changed using the decrease and increase buttons).

The next parameter TSLo is set to -100 (corresponds to an unrealistic temperature).

Completion of parameter changes – Good is displayed on the display.

For rational use of available resources, the outputs of the BP-10V2 regulator are made on the same connector as in the TKP-160Sg. The difference lies in the functioning of both devices (output 1 of the regulator directly performs two-position regulation (setpoint t0) with the regulated zone C\_Pr, and in the TKP-160Sg two groups of contacts are used for such regulation). It is impossible to implement the limit temperature signaling in the same TKP -160Sg.

Thus, one meter - regulator BP-10V2, performing simultaneously the functions of measurement, regulation and signaling, is able to replace two TKP-160 devices.

The actuators are connected to the normally open contacts of the BP-10V2 (output 1 (regulation) - contacts 1-4, output 2 (alarm) - contacts 1-2).

The 220V mains power cable and the TOP-109-52 resistance thermal converter signal cable are routed through hermetic entries of protection class IP67 inside the meter-regulator housing (to prevent loss of tightness and loss of the manufacturer's declared protection class IP65, it is not recommended

disassemble the meter-regulator housing). When installing the BP-10V2 regulator outside the premises or on the roof, it is advisable to use an external protective housing. This provides additional protection against intense climatic influences: hail, dust, rain, snowfall, etc. In this case, in addition to the regulator housing itself, the connector for connecting external circuits and the outputs of corrugated pipes with cables become protected: In one hole, it is necessary to insert the power cable and the TOP-109-52 cable, in the other - a cable with a RSh20 connector from the control cabinet.

To insert the signal cable of the TOP-109-52 thermal converter into the hole of the additional housing, it is necessary to temporarily remove the nozzle from the thermal converter.

The outer protective case can be fixed with four fasteners through the holes in the corners of the lower part of the case. If the case will be installed in place of the TKP-160Sg, then on the lower part of the case there is a marking of 128x128 mm, in which it is necessary to drill 4 holes with a diameter of 7 mm.

When screwing into these holes, it is necessary to put rubber gaskets on the outside or seal them with silicone.

#### Factory settings:

Parameter	Value
tYPE	P1.0
Func	2__in
t0	50.0
C_Pr	5.0
tShi	80.0
tSLo	-100

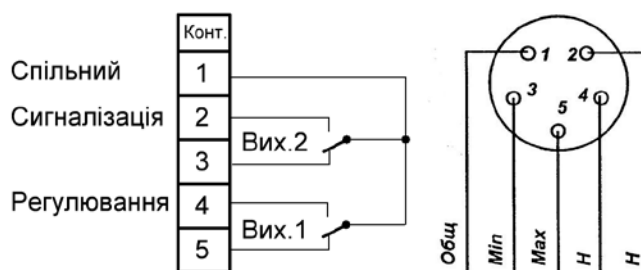
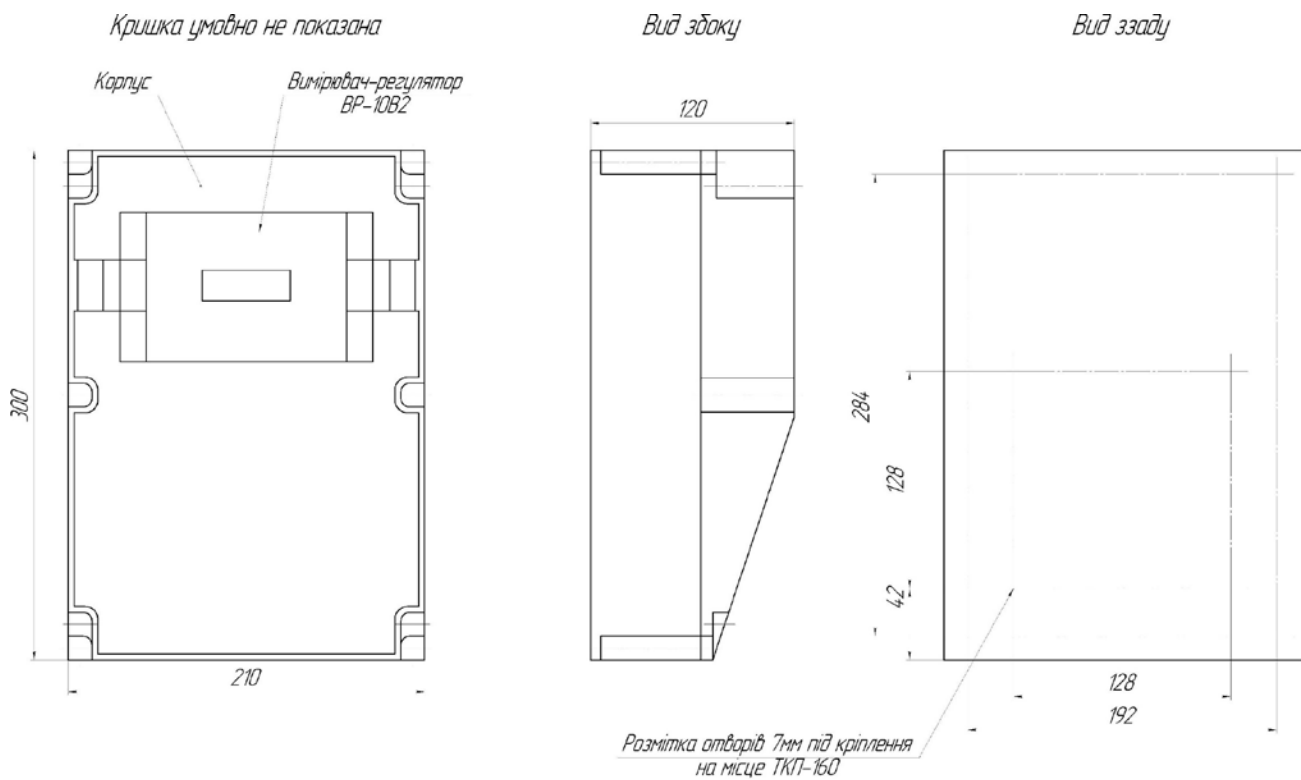
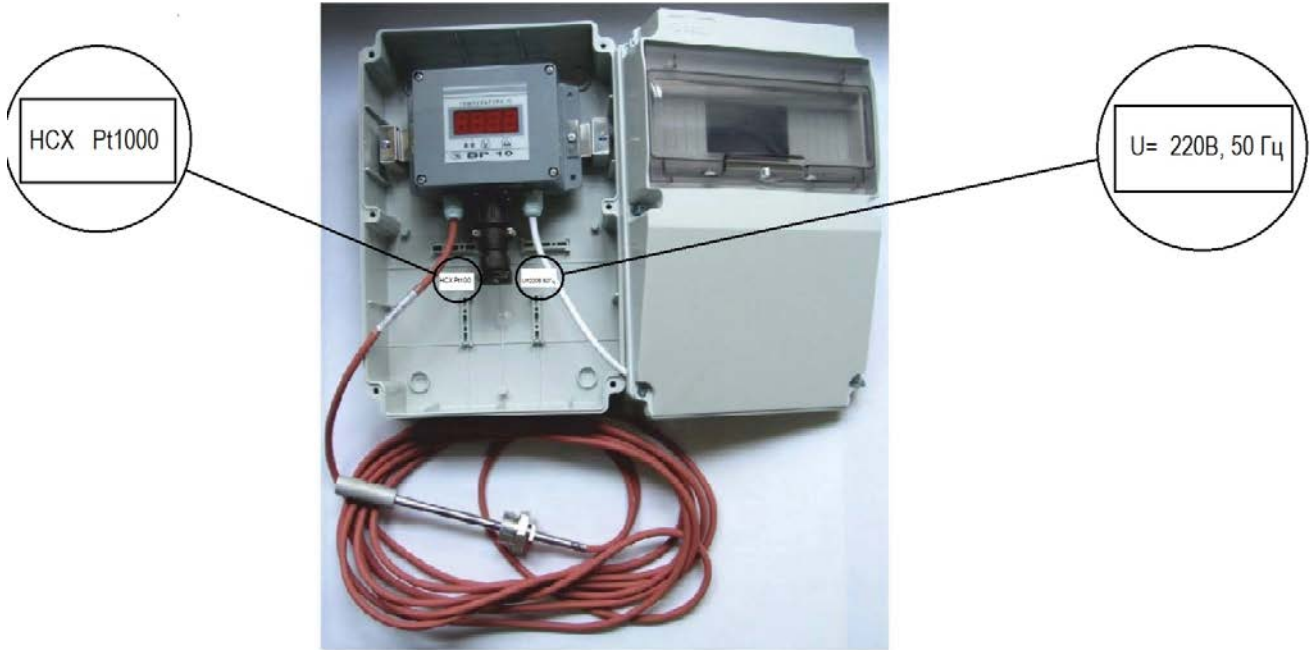

Fig. 1.  
Contacts  
connector BP-10V2

Fig. 2.  
TKP160 connector  
contacts

## Appendix 7

### Option for installing the BP-10B2 meter-regulator in an additional protective housing



## Appendix 8

### Option for implementing backup power in the BP-10B2 regulator for indicating the measured temperature

In the event of a power failure in the stationary AC network, the indication of the temperature measured by the BP-10B2 regulator can be restored at the time the backup power connection button is pressed.

To do this, you must first open the transparent cover-door on the front panel of the regulator's protective housing, and then press the large red "Backup power" button.

The nominal voltage of such a backup autonomous DC power supply is 10.8 V (three LS18500 batteries connected in series).

The guaranteed service life of such a battery is 10 years with a total backup power usage time of 40 hours and 20 years with a total usage time of 25 hours.

If the battery discharges below the permissible value, the indication will go out. In this case, the backup autonomous power supply must be replaced.

## Appendix 9

### Option for installing the BP-10B regulator without an additional protective housing

a) at the installation site of TKP-160Sg

b) in any place

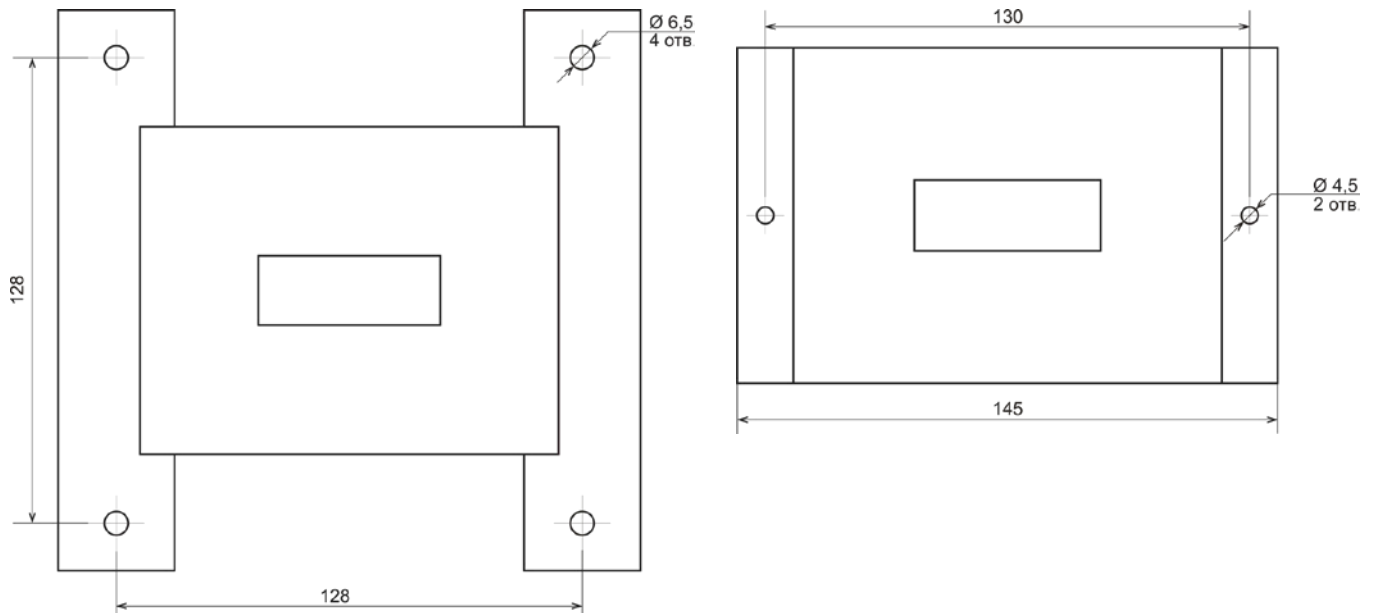

## Appendix 10

### Explosion-proof pressure gauge-regulator BP-10Ex

Meter-regulator BP-10Ex explosion-proof version (explosion protection marking **II 2(1)G Ex db [ia Ga] IIC T5 Gb**) (hereinafter referred to as the controller) is designed to measure temperature in conjunction with temperature transducers, regulate the value according to a given regulation law and issue an alarm if the measured value exceeds the set limits or issue two alarm levels for the set limits.

Intended for use in Zone 1 where explosive gas atmospheres may occur.

environment of subgroup IIC, temperature class T5, made with type of protection "d", which provides protection level Gb and contains a protective device with output intrinsically safe circuits of level "ia", which are connected to level Ga equipment intended for use in potentially explosive gas environments of subgroup IIB.

#### 1. MAIN TECHNICAL CHARACTERISTICS

1.1. Symbol of the regulator	BP-10Ex
1.2. Measurement and control (alarm) range, °C	-50...160
1.3. Nominal static characteristic of the resistance thermal transducer	Pt1000
1.4. Limit of permissible basic error of the regulator, °C	$\pm(0,5+0,001 T )$
1.5. Limit of permissible basic error of the regulator complete with a class B resistance thermal converter, °C	$\pm(0,8+0,006 T )$
1.6. The value of the smallest digit when indicating temperature, °C	0,1
1.7. Power supply, V, Hz	220 (+22,-33), 50±1
1.8. Power consumption, no more than, W	2
1.9. Exit	
-Exit 1	contacts of the relay NO (100W, 220V)
-Exit 2	contacts of the relay NO (100W, 220V)
1.10. Permissible and nominal parameters of input circuits (thermal converter circuits)	
1.10.1. Inductance, not more than, mH	5
1.10.2. Capacitance, not more than, µF	7
1.10.3. Lack of own non-intrinsically safe circuits in the explosive zone	So
1.10.4. Rated fuse current in input circuits, mA	50
1.10.5. Tripping voltage of the spark protection circuit, V	6,8
1.10.6. Maximum current through the thermal converter, mA	0,6
1.10.7 Permissible short-circuit current, mA	110
1.11. Degree of protection	IP65
1.12. Overall dimensions, mm	175 x 128 x 128 x 88
1.13. Average service life, not less than, years	10
1.14. Mass, not more than, kg	1
1.15. Operating conditions:	
-ambient temperature, °C	from minus 40 to 60
-relative air humidity at a temperature of 35°C, not more than, %	98
-atmospheric pressure, kPa	from 84 to 106.7

## 2. CONSTRUCTION AND OPERATION

The regulator includes a TOP-109-52 resistance thermal converter. The front panel of the regulator has a digital indicator, two magnetically sensitive buttons, and two LEDs 1 and 2, which display the status of the corresponding outputs (relay contacts).

The controller can be programmed for different operating modes (see operating instructions).

In the described variant, two-position regulation with signaling of the measured value exceeding the set limits and three-position regulation or its modification - two-level signaling are potentially available.

### 2.1 Using the BP-10Ex regulator to replace the explosion-proof signaling thermometers TGP-16Sg and TKP-16Sg

To implement the function of the mentioned thermometers, the regulator uses a three-position "increase-decrease" (Func= is selected by default in the regulator menu).  $\text{3}_\text{Lo}$ .

The lower (minimum) alarm value is selected by bringing the magnetic stylus closer to the button image. ▼ At the same time, the digital indicator displays the designation of the lower setpoint toLo, and later its value. The setpoint value can be changed by bringing the stylus closer to the corresponding button (increase or decrease). After setting, remove the stylus, wait 3 seconds. The appearance of the inscription Good indicates that the new setpoint value has been recorded in the controller's memory. The signaling of reaching the lower temperature value is accompanied by the lighting of LED 1 (green) and the closing of the pair of contacts "relay 1 - relay general."

The upper (maximum) alarm value is selected similarly, but by initially bringing the magnetic stylus closer to the button image. ▢. At the same time, the digital indicator displays the designation of the upper setpoint toNo, and later its value. The setpoint value can be changed by bringing the stylus closer to the corresponding button (increase or decrease). After setting, remove the stylus, wait 3 seconds. The appearance of the inscription Good indicates that the new setpoint value has been recorded in the controller's memory. The signaling of reaching the upper temperature value is accompanied by the lighting of LED 2 (red) and the closing of the pair of contacts "relay 2-relay common."

## 3. INSTALLATION. SPECIAL CONDITIONS OF USE.

Only personnel who have been instructed in safety issues and are specially trained to work with similar equipment are allowed to work with the BP-10Ex.

When installing the BP-10Ex, it is necessary to be guided by the following regulatory documents:

- a) NPAOP 40.1-1.32-01 Rules for the construction of electrical installations. Electrical equipment of special installations, section 4 Electrical installations in explosive areas;
- b) NPAOP 40.1-1.21-98 Rules for the safe operation of electrical installations of consumers, subsection 7.3 Electrical installations in explosive areas;
- c) PTEES Rules for the technical operation of electrical installations of consumers, subsection 7.4 Electrical installations in explosive areas;
- d) VSN 332-74 Instructions for installation of electrical equipment, power and lighting networks in hazardous areas;
- e) operating instructions TMIR.421413.114 NE;
- f) operating instructions for products that include BP-10Ex.

Before installation, check the completeness, marking, and absence of damage to the BP-10Ex shell, and keep it at a temperature of  $(25 \pm 10)$  °C and relative humidity from 30 to 80% for 1-2 hours.

Installation should be carried out with the power supply switched off according to the connection diagram to the external circuits (Fig. 1) and the internal markings of the BP-10Ex. In this diagram, the color of the conductors corresponds to the five-wire MKESHng cable. The cable diameter should be from 7 mm to 14 mm. The cross-section of the cable core should not be less than  $0.75 \text{ mm}^2$ .

The actuators are connected to the normally open contacts of the relay outputs of the BP-10Ex

(output 1 – contacts 1-3, output 2 – contacts 2-3).

The 220V mains power cable with relay outputs must be routed through a cable entry with an internal entry hole from 7 mm to 14 mm into the inside of the regulator housing. A possible version of the regulator is that the manufacturer supplies the regulator with a built-in piece of cable of a certain length (typically 6 m). In this case, the regulator housing is sealed with a self-destructive seal.

The BP-10Ex housing has an external grounding clamp (marked with a grounding symbol), to which a grounding cable must be connected.

**The BP-10Ex measuring regulators must be connected at one point to the potential equalization system!**

The BP-10Ex should not be exposed to shock, vibration, external magnetic fields (except terrestrial), precipitation, and direct sunlight..

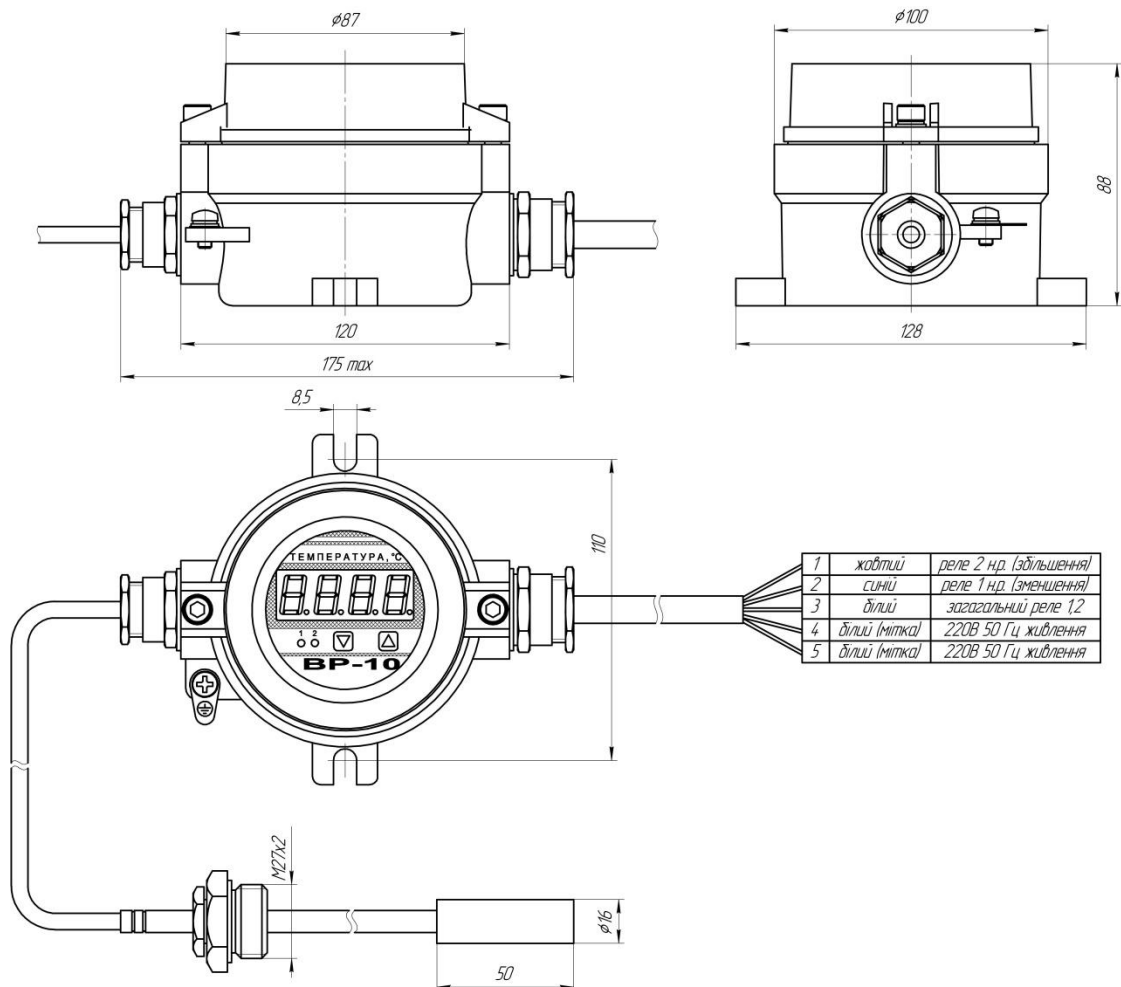

Fig. 1. Overall and installation dimensions of the BP-10Ex.

## Appendix 11

### Using the BP-10B-K-100 regulator (hereinafter referred to as BP-10) to replace the TKP-100

In the BP-10, output 1 (regulation) implements the function of turning the actuator on/off, and output 2 generates an alarm when the limit temperature is reached.

The display of the BP-10 regulator indicates the current temperature. The left (red) LED 1 shows the status of output 1 (regulation), the right (green) 2 - the status of output 2 (alarm).

The regulation law is two-pronged.

The control parameter is the t0 setpoint. The reversal zone during control is implemented by the C\_Pr parameter. The limit temperature alarm setpoint is implemented by the tShi parameter (the upper alarm setpoint for the controller). The reversal zone with this setpoint corresponds to the value of the lowest digit.

Magnetic contactor (acts as a button) by affecting the reduction zones  $\nabla$  or increase  $\Delta$  opens on the indicator t0, and then its value, which is changed by contacting the decrease, increase zones.

After the contactors have been operating for a few seconds on both zones, the TYPE parameter (temperature transducer NSC) appears on the display. When using a temperature transducer with NSC Pt1000, the value P1.0 is set. After this, the Func parameter (control law) appears, which is set to 2\_\_u (in our case, 2-position reduction or cooling).

Next, the parameter t0 appears, which is already set, followed by C\_Pr (the reversal zone, the change in its value is carried out by the contactor's influence on the decrease and increase zones).

The next parameter is tShi (the upper alarm setpoint, corresponding to the limit temperature, the change of which is carried out by the contactor's influence on the decrease and increase zones).

The next parameter TSLo is set to -100 (corresponds to an unrealistic temperature).

Completion of parameter changes – Good is displayed on the display.

For rational use of available resources, the outputs of the BP-10 regulator are made on the same connector as in the TKP-100. The difference lies in the functioning of both devices (output 1 of the regulator directly performs two-position regulation (setpoint t0) with the regulated zone C\_Pr, and in the TKP-100 two groups of contacts are used for such regulation).

Thus, one meter - regulator BP-10, performing simultaneously the functions of measurement, regulation and signaling, is able to replace two TKP-100 devices.

The actuators are connected to the normally open contacts of the BP-10 (output 1 (regulation) - contacts 1-2, output 2 (alarm) - contacts 3-4).

The 220V mains power cable and the TOP-109-52 resistance thermal converter signal cable are routed through hermetic entries with IP67 protection degree into the inside of the meter-regulator housing (to prevent loss of tightness and loss of the IP65 protection degree declared by the manufacturer, it is not recommended to disassemble the meter-regulator housing).

#### Factory settings:

Parameter	Value
tYPE	P1.0
Func	2__in
t0	50.0
C_Pr	5.0
tShi	80.0
tSLo	-100



Fig. 1.  
Contacts  
BP-10 connector

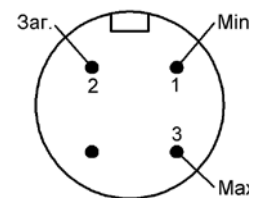
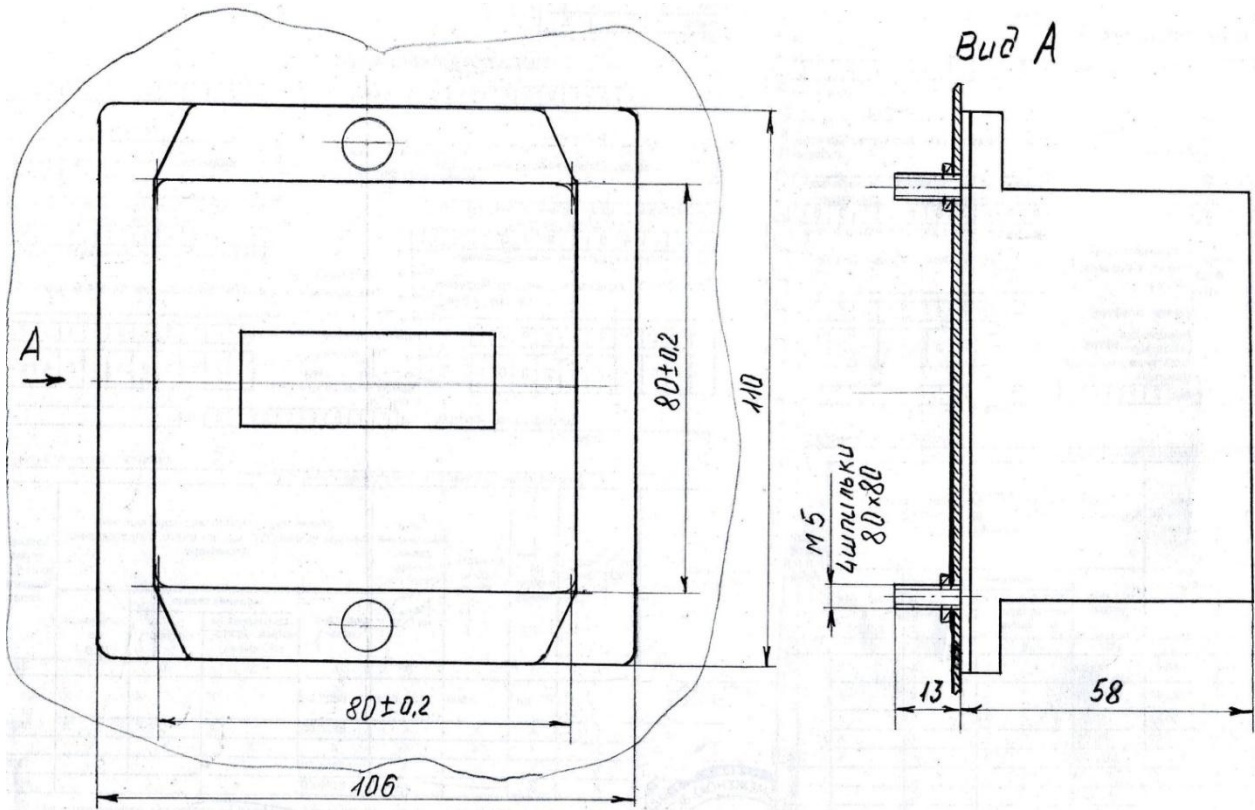
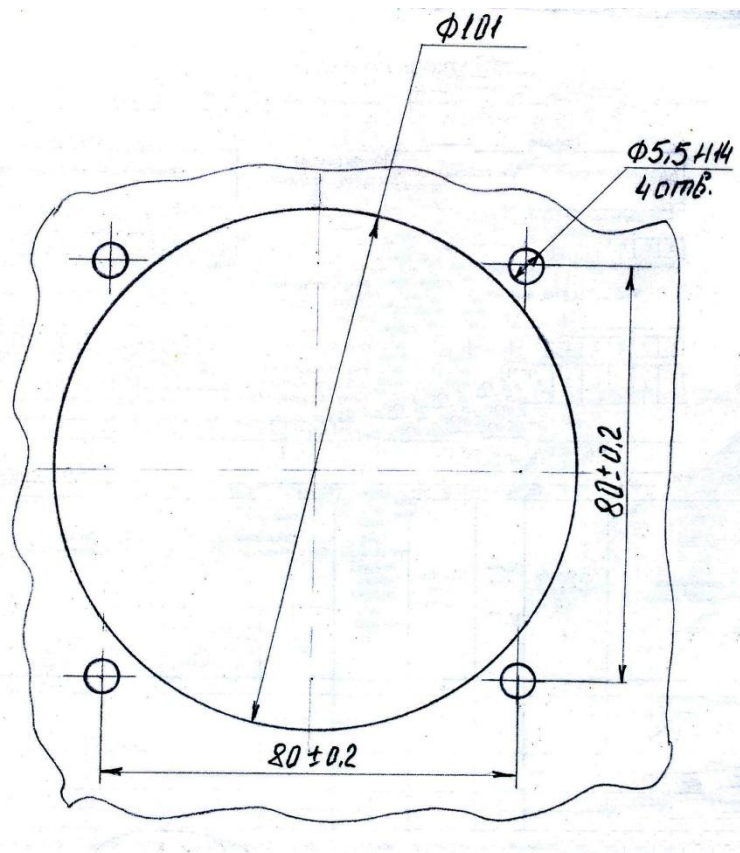

Fig. 2.  
Contacts  
TKP-100  
connector

**Mounting the BP-10B-K-100 on a panel**



**Holes in the shield for mounting BP-10B-K-100**



## Appendix 12

### Meter - regulator BP-10B2A for nuclear power plants

The BP-10V2A measuring and regulating device (hereinafter referred to as the regulator) is designed to measure temperature in conjunction with a temperature converter (mainly TOP-109-52A), regulate the value according to a given regulation law and issue an alarm if the measured value exceeds the set limits or issue two alarm levels beyond the set limits.

#### 1. MAIN TECHNICAL CHARACTERISTICS

1.1. Symbol of the regulator	BP-10V2A
1.2. Measurement and control (alarm) range, °C	-50...160
1.3. Nominal static characteristic of the resistance thermal transducer	Pt1000
1.4. Limit of permissible basic error of the regulator, °C	$\pm(0,5+0,001 T )$
1.5. Limit of permissible basic error of the regulator complete with a class B resistance temperature transducer, °C	$\pm(0,8+0,006 T )$
1.6. The value of the smallest digit when indicating temperature, °C	0,1
1.7. Power supply, V, Hz	230 $\pm$ 10%, 12...36, 50 $\pm$ 1, constant 12...36, or other, according to customer specifications
1.8. Power consumption, no more than, W	2
1.9. Exit	
- Exit 1, Exit 2	PRM relay contacts (60W, 250V DC, 1000W, 240V AC)
1.10. Degree of protection	IP65
1.11. Interface	RS485 (or other)
1.12. Overall dimensions (without cable part), mm	147 x 110 x 63
1.13. Average service life, not less than, years	10
1.14. Probability of failure-free operation for 10,000 hours, not less	0,95
Impact resistance	10 g, 10 msec any plane
Vibration resistance group, no worse	N2
1.15. Mass, not more than, kg	1
1.16. Operating conditions:	
- ambient temperature, °C	from minus 40 to 60
- relative air humidity at a temperature of 35°C, not more, %	98
- atmospheric pressure, kPa	from 84 to 106.7

#### 2. CONSTRUCTION AND OPERATION

The regulator includes a resistance thermal transducer (usually TOP-109-52A). On the front panel of the regulator there is a digital indicator, two buttons, two LEDs 1 and 2, which display the status of the corresponding outputs (relay contacts) (Fig. 1-3).

The controller can be programmed for different operating modes (see operating instructions).

In the described variant, two-position regulation with signaling of the measured value exceeding the set limits and three-position regulation or its modification - two-level signaling are potentially available.

To perform the specified measurement and control functions, the controller must be powered from a stationary power supply. If the controller is powered from an AC power supply, additional backup power from a battery is possible. When powered from a DC source as the main power supply, the controller does not have a backup power supply. However, it is possible (optionally) to supply a low-power battery pack for short-term indication of the measured temperature (without control) in emergency conditions, etc.

### 3. USE OF THE BP-10B2A REGULATOR, INCLUDING AS A REPLACEMENT FOR QUALITROL 104/TR6000 ALARM THERMOMETERS AND OTHER MANOMETRIC THERMOMETERS - ALARMS

In the BP-10B2A, output 1 (regulation) implements the function of turning on/off the blowing (cooling) of a power transformer or other power device, and output 2 generates an alarm when the limit temperature is reached.

The display of the BP-10V2A controller indicates the current temperature. The left (red) LED 1 shows the status of output 1 (regulation), the right (green) 2 - the status of output 2 (alarm).

The regulation law is two-pronged.

The control parameter is the t0 setpoint. The reversal zone during control is implemented by the C\_Pr parameter. The limit temperature alarm setpoint is implemented by the tSHi parameter (the upper alarm setpoint for the controller). The reversal zone with this setpoint corresponds to the value of the lowest digit.

The t0 setting is called by pressing one of the buttons, after which t0 appears on the indicator, followed by the setting value, which is changed by the buttons (left or bottom - decrease, right or top - increase).

After pressing both buttons for a few seconds, the TYPE parameter (temperature transducer NSC) appears on the display. When using a temperature transducer with NSC Pt1000, the value P1.0 is set. After that, the Func parameter (control law) appears, which is set to 2\_\_u (in our case, 2-position reduction or cooling).

Next, the parameter t0 appears, which is already set, followed by C\_Pr (the return zone, the value of which is changed using the decrease and increase buttons).

The next parameter is tSHi (upper alarm setpoint, corresponding to the limit temperature, which is changed using the decrease and increase buttons).

The next parameter TSLo is set to -100 (corresponds to an unrealistic temperature).

Completion of parameter changes – Good is displayed on the display.

Output 1 of the controller performs two-position regulation (setpoint t0) with the regulated zone C\_Pr, and output 2 provides signaling.

The actuators are connected to the normally open contacts of the BP-10V2A via a connector (output 1 (regulation) – contacts 1 and 4, output 2 (alarm) – contacts 1 and 2 of the connector). The power supply to the meter-regulator is supplied via the same connector (contacts 6 and 7).

The connector should be mounted with conductors with a cross-section of at least 0.35 mm (depending on the specified current through the relay contacts).

The TOP-109-52A thermal converter should be mounted according to its installation dimensions. The most important are two typical TOP-109-52A designs (Fig. 2): immersed directly into the volume of the measured medium and immersed in a “pocket” that contacts the medium. Thermal converters have a cable version. The thermal converter housing is connected directly to the signal cable or through a connector. The cable (mainly silicone) can be additionally pulled into a metal sleeve.

The signal cable of the TOP-109-52A resistance temperature transducer is routed through a sealed IP67 protection grade entry into the meter-regulator housing (to prevent leakage and loss of the IP65 protection grade declared by the manufacturer, it is not recommended to disassemble the meter-regulator housing multiple times). When using an additional output in the regulator (for example, an RS485 interface or others), an additional sealed entry with a communication cable is output (Fig. 3 - 4). If the RS485 cable is mounted in the manufacturer's conditions, then the blue and orange conductors connected in parallel correspond to output A, and the green and brown conductors to output B. When installing the BP-10V2A regulator outside the premises or on the roof, it is advisable to use an external protective housing, which may be included in the delivery set (Fig. 5). This provides additional protection against intense climatic influences: hail, dust, rain, snowfall, etc. In this case, in addition to the regulator housing itself, the connector for connecting external circuits and other circuits become protected. In one hole, it is necessary to insert the TOP-109-52A cable, in the other - the cable with the connector from the control cabinet.

The outer protective case can be secured with four fasteners through the holes in the corners of the lower part of the case.

**Factory settings:**

Parameter	Value
tYPE	P1.0
Func	2__in
t0	50.0
C_Pr	5.0
tShi	80.0
tSLo	-100



*Fig. 1. Contacts of the 2PM18 connector (or similar) in the BP-10B2A*

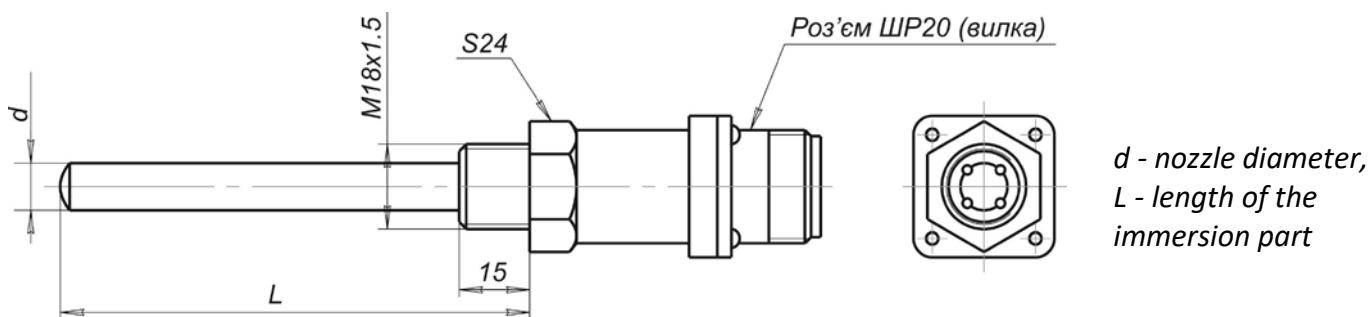

a) thermal converter TOP-109-52A for immersion directly into the volume of the measuring medium

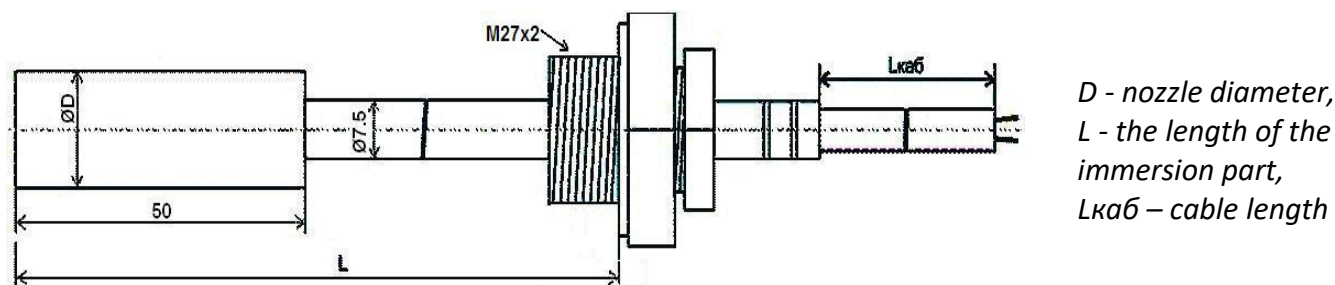

b) TOP-109-52A thermal converter for immersion in a "pocket" in contact with the measuring medium.

Fig. 2.



Appearance of the BP-10-B2A regulator with TOP-109-52A thermal converter  
Fig. 3.

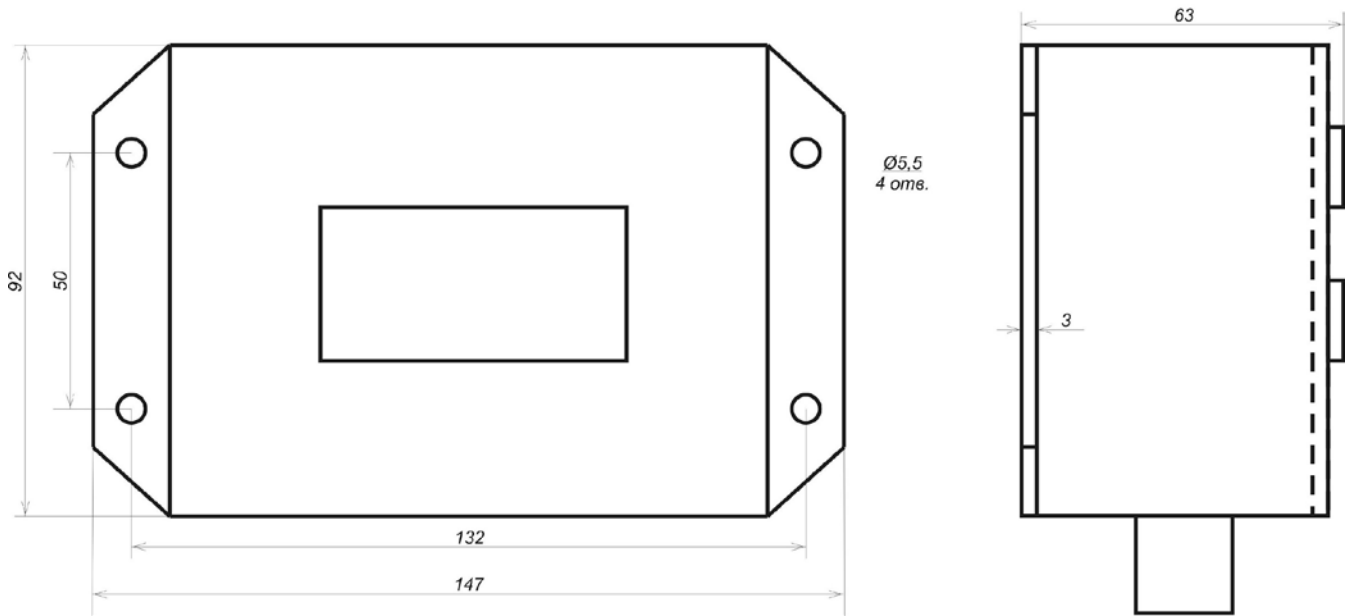

a) installation of the BP-10B2A regulator without an additional protective housing

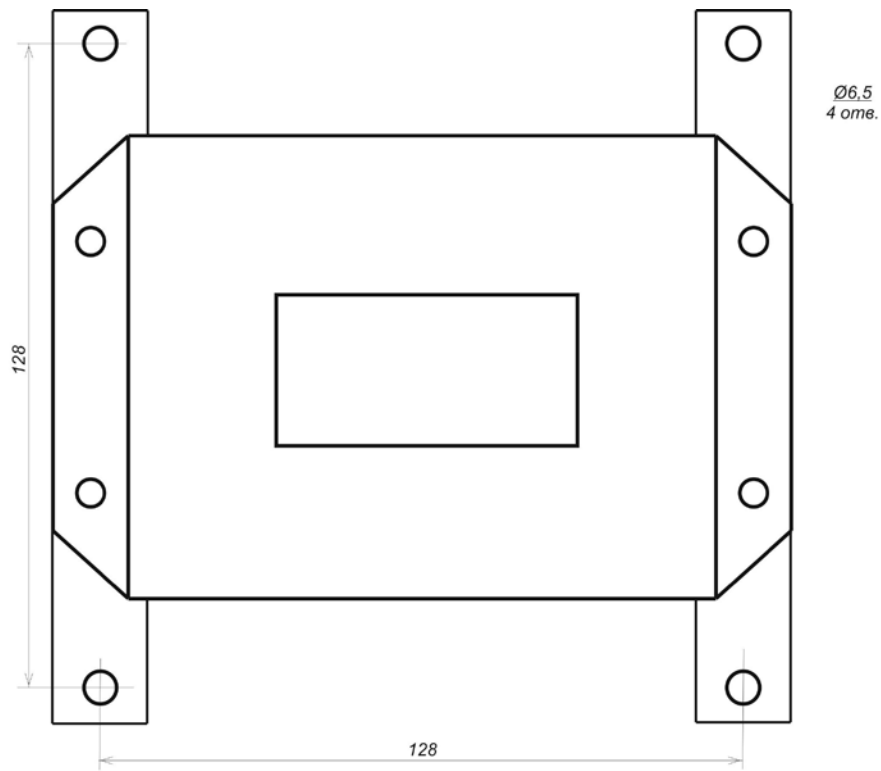

b) installation of the BP-10B2A regulator at the installation site of the TKP-160Sg

Fig. 4.



*Кришка умовно не показана*

*Вид збоку*

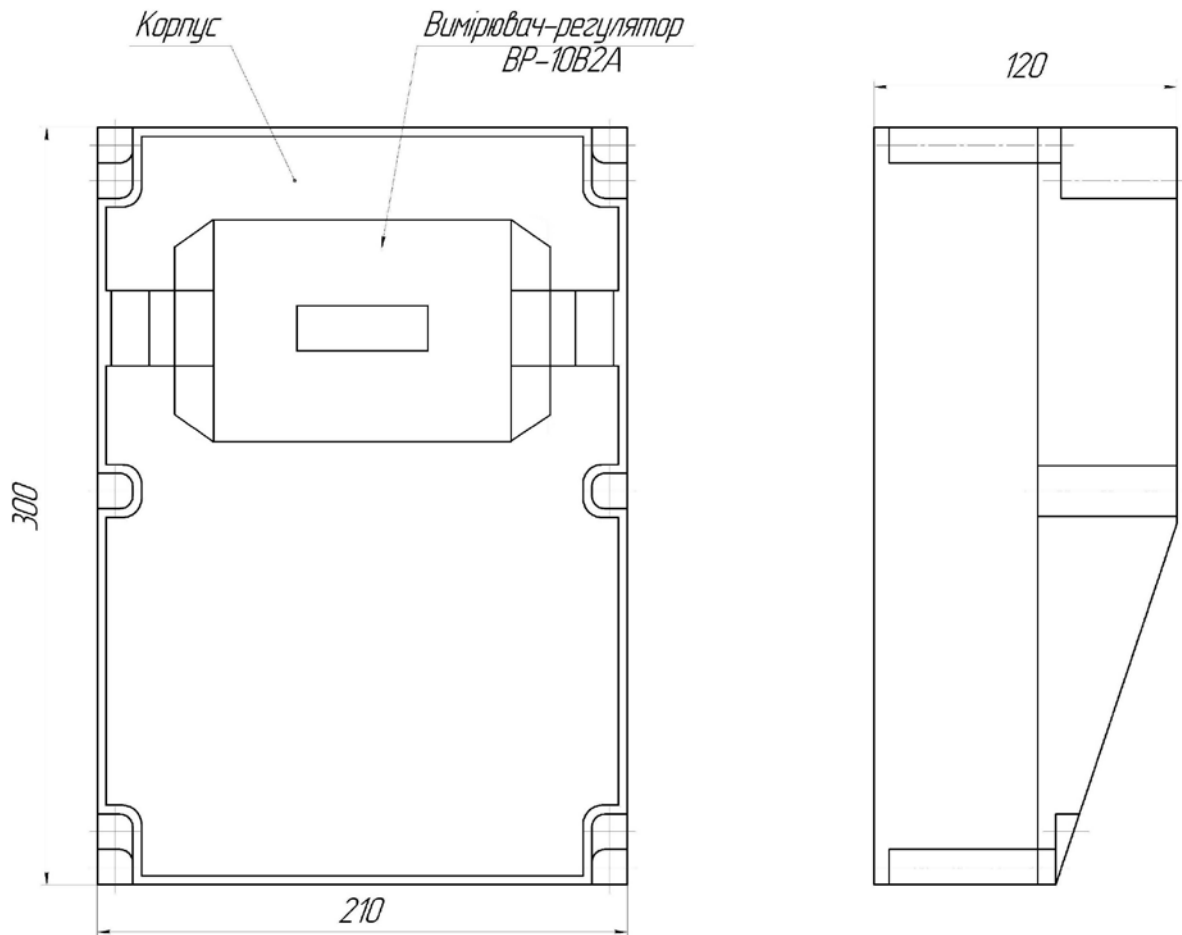

*Option for installing the BP-10B2A regulator in an additional protective housing*

*Fig. 5.*