

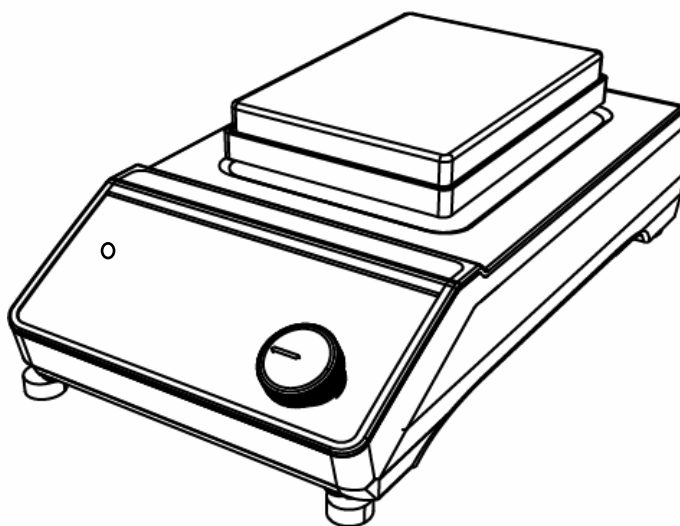

Micro plate Mixer user manual



Please read the User Manual carefully before use, and follow all operating and safety instructions! Technical specifications and outline are subject to change without prior notice.

12302086



Ver.20220118



Mixing



CONTENTS

Preface.....	1
Service	1
Warranty.....	2
1. Safety Instructions.....	3
2. Proper use.....	5
3. Inspection.....	5
3.1. Receiving Inspection.....	5
3.2. Listing of Items.....	6
4. Operation	6
5. Control.....	7
6. Maintenance and cleaning	7
7. Associated standards and regulations	9
8. Technical data	10





Preface

Welcome to the “Microplate Mixer User Manual”. Users should read this Manual carefully, follow the instructions and procedures, and beware of all the cautions when using this instrument

Service

When help needed, you can always contact the service department of manufacturer for technical support.

Please provide the customer care representative with the following information :

- Serial Number (on the rear panel)
- Description of problem (i.e., hardware or software)
- Methods and procedures adopted to resolve the problems
- Your Contact Information



Mixing



Warranty



This instrument is warranted to be free from defects in materials and workmanship under normal use and service, for a period of 24 months from the date of Invoice.

The warranty is extended only to the original purchaser. It shall not apply to any product or parts which have been damaged on account of improper installation, improper connections, misuse, accident or abnormal conditions of operation.

For claims under the Warranty please contact your local supplier. You may also send the instrument directly to manufacturer, enclosing the invoice copy and by giving reasons for the claim. You would be solely liable for freight costs.



1. Safety Instructions

	<p>Warning!</p> <ul style="list-style-type: none"> ● Read the operating instructions in full before use and follow the safety instructions ● Ensure that only trained staff work with the appliance.
	<p>Protective ground contact!</p> <ul style="list-style-type: none"> ● Make sure that socket is earthed (protective ground contact) before use.

- When work, wear the personal guard to avoid the risk from:
 - Splashing of liquids.
 - Release of toxic or combustible gases.
- Set up the instrument in a spacious area on an even, stable, clean, non-slip, dry and fireproof surface, do not operate the instrument in explosive atmospheres, with hazardous substances or under water.
- Gradually increase the speed, reduce the speed if:
 - The medium splashes out of the vessel because of too high speed.
 - The instrument is not running smoothly.
- Beware of hazards due to:
 - Overfilling of media



- Unsafe container
- Process pathogenic materials only in closed vessels.
- Always disconnect the plug before fitting accessories. Do not use damaged components.
- The operating voltage required on the type plate and voltage supply network must match.
- Ensure that the mains power supply cable does not touch the hotplate. Do not cover the instrument.
- Single microplate clamp and double microplate clamp can not be changed more than 10 times, otherwise increases the risk of screw slip.
- The instrument may only be opened by experts Observe the minimum distances between the devices, between the instrument and the wall and above the assembly (min. 100 mm).



2. Proper use

The instrument is designed for schools, laboratories or factories. This device is not suitable for use in residential areas or other areas that may cause danger to the user or instrument as mentioned in Chapter 1.

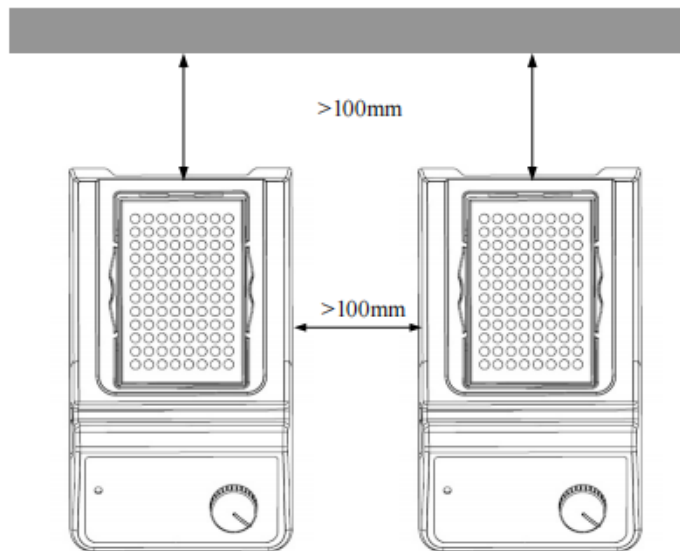



Figure 1

3. Inspection

3.1. Receiving Inspection

Unpack the equipment carefully and check for any damages which may have arisen during transport. If it happens, please contact manufacturer/supplier for technical support.

	<p>Note:</p> <p>If there is any apparent damage to the system, please do not plug it into the power line.</p>
--	--

3.2. Listing of Items

The package includes the following items:

Items	Qty
Main unit	1
Power adaptor	1
User Manual	1

Table 1

4. Operation

- Make sure that the required operating voltage and power supply voltage match.
- Ensure the power be off and the speed control knob at the lowest position. Plug in the power adapter.
- Place a microtiter or other vessel in holder
- Power ON the device and the Power LED is lit
- Set the rated speed regulation and the device begins to work.
- Set the rated speed regulation to „0“and the device stop to work.

- Power OFF the device.

If these operations above are normal, the device is ready to operate. If these operations are not normal, the device may be damaged during transportation, please contact technical support of manufacturer/supplier.

5. Control

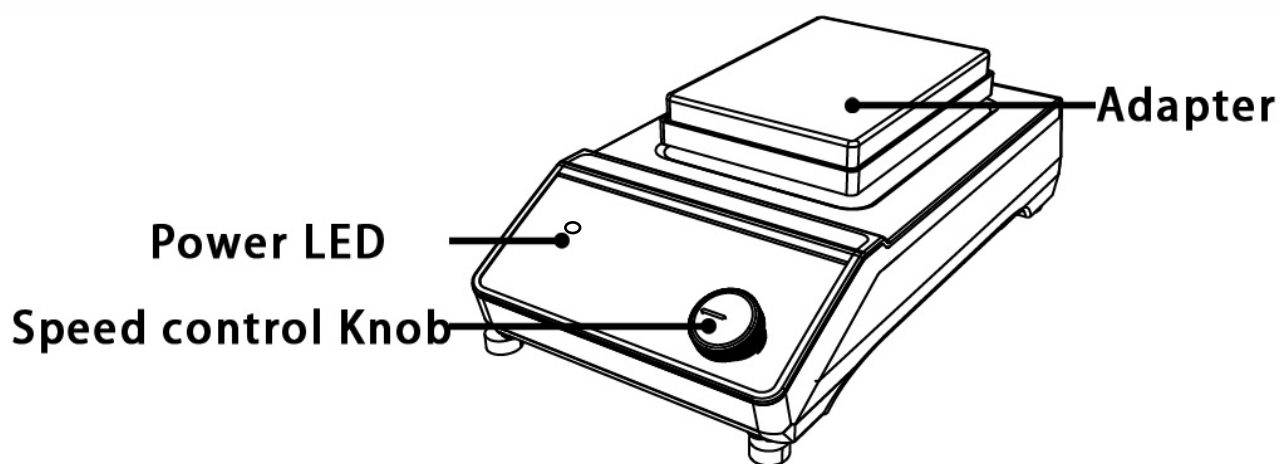

Figure 2

6. Maintenance and cleaning

Proper maintenance can keep instruments working in a good state and lengthen its lifetime. Be careful not spray the cleanser into the instrument when cleaning.

Unplug the power line when cleaning. Only use cleanser that we advised as below:





Dyes	isopropyl alcohol
Construction materials	water containing tenside/ isopropyl alcohol
Cosmetics	water containing tenside/ isopropyl alcohol
Foodstuffs	water containing tenside
Fuels	water containing tenside

- Before using other method for cleaning or decontamination, the user must ascertain with the manufacturer that this method does not harm or destroy the instrument.
- Wear the proper protective gloves during cleaning of the instrument.
- Forbid to place the instrument in the cleanser to clean.
- The instrument must be cleaned and put it into the initial packaging carton before sending to service for repair, avoiding the contamination of hazardous.
- Switch off the device and put it in the dry, clean, stable
- place at room temperature in long-term disuse.



7. Associated standards and regulations

Construction in accordance with the following safety standards:

EN 61010-1

Construction in accordance with the following EMC standards:

EN 61326-1

Associated EU guidelines:

EMC-guidelines: 89/336/EEG

Machine guidelines: 73/23/EEG



8. Technical data

Items	Parameters
Voltage [VAC]	100~240
Frequency [Hz]	50/60
Power [W]	20
Shaking movement	Orbital
Orbital diameter [mm]	4.5
Max. shaking weight (with attachments) [kg]	0.5
Motor type	External rotor brushless motor
Motor rating input [W]	18
Motor rating output [W]	10
Permissible ON time [%]	100
Speed range [rpm]	0-1500 0-1000 (Double microplate clamp)
Speed display	Scale
Microplate working	Yes
Microplate amount	1 (Single microplate clamp) 2 (Double microplate clamp)
Dimensions (mm)	260×150×80



Weight [kg]	3
Permitted ambient temperature[°C]	5–40
Permitted relative humidity	80%
Protection class acc. to DIN 60529	IP21

Table 2



Mixing



CONTACT US



DLAB Scientific Co., Ltd

Yu An Road 31, Beijing Airport Economic core zone,

Shun yi District, Beijing, China 101318

Tel: 86-10- 85653451/52/53

Fax: 86-10-85653383

E- mail: info@dlabsci.com

web: www.dlabsci.com