

**Resona I9/Resona I9 Exp/Resona I9S/
Resona I9T/Resona I9 Easi/Resona I9
Nasa/Resona I9W/Anesus I9/Anesus I9
Easi/Eagus I9/Resona IV/Resona IX/
Resona I Super/Imagyn I9/Imagyn I9S/
Imagyn I9 Easi/Nuewa I9/Nuewa I9S/
Nuewa I9 Easi/Nuewa I9T/Nuewa I9 Exp/
Nuewa IX/Nuewa I9W/Nuewa IV/Nuewa I
Super/Recho I9/Recho I9 Pro/Recho I9
Exp/Recho I9S/Recho I9T**

Diagnostic Ultrasound System

Operator's Manual

[Basic Volume]

Item	Model
iVocal Microphone	SAMSON XPD2 (iVocal should be configured)
Barcode reader	LS2208 DS4308
Footswitch	FS-81-SP-2 (1-pedal) 971-SWNOM (2-pedal) 971-SWNOM (3-pedal)

2.6.5 Parts that can be used within patient environment

- Main unit
- Probes
- Footswitch
- Printers

2.7 Introduction of Each Unit

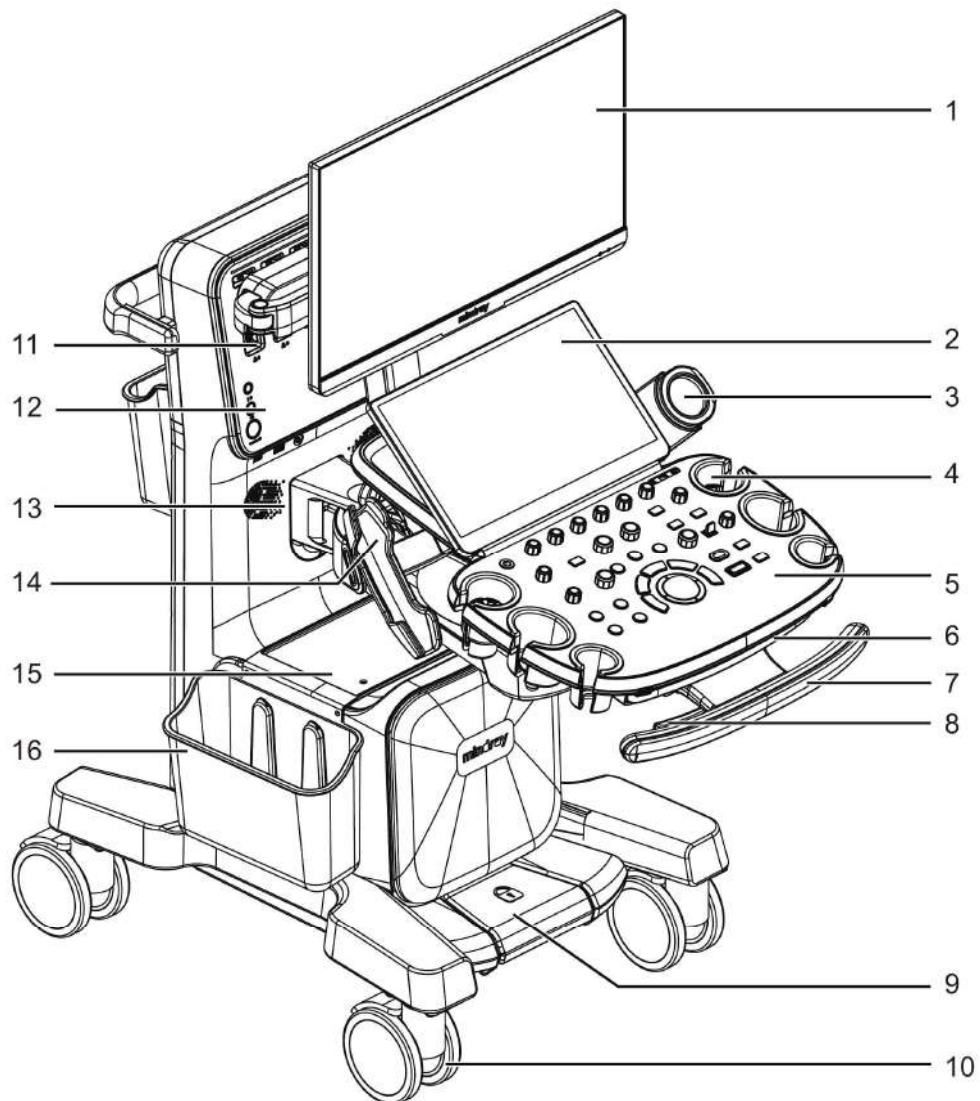

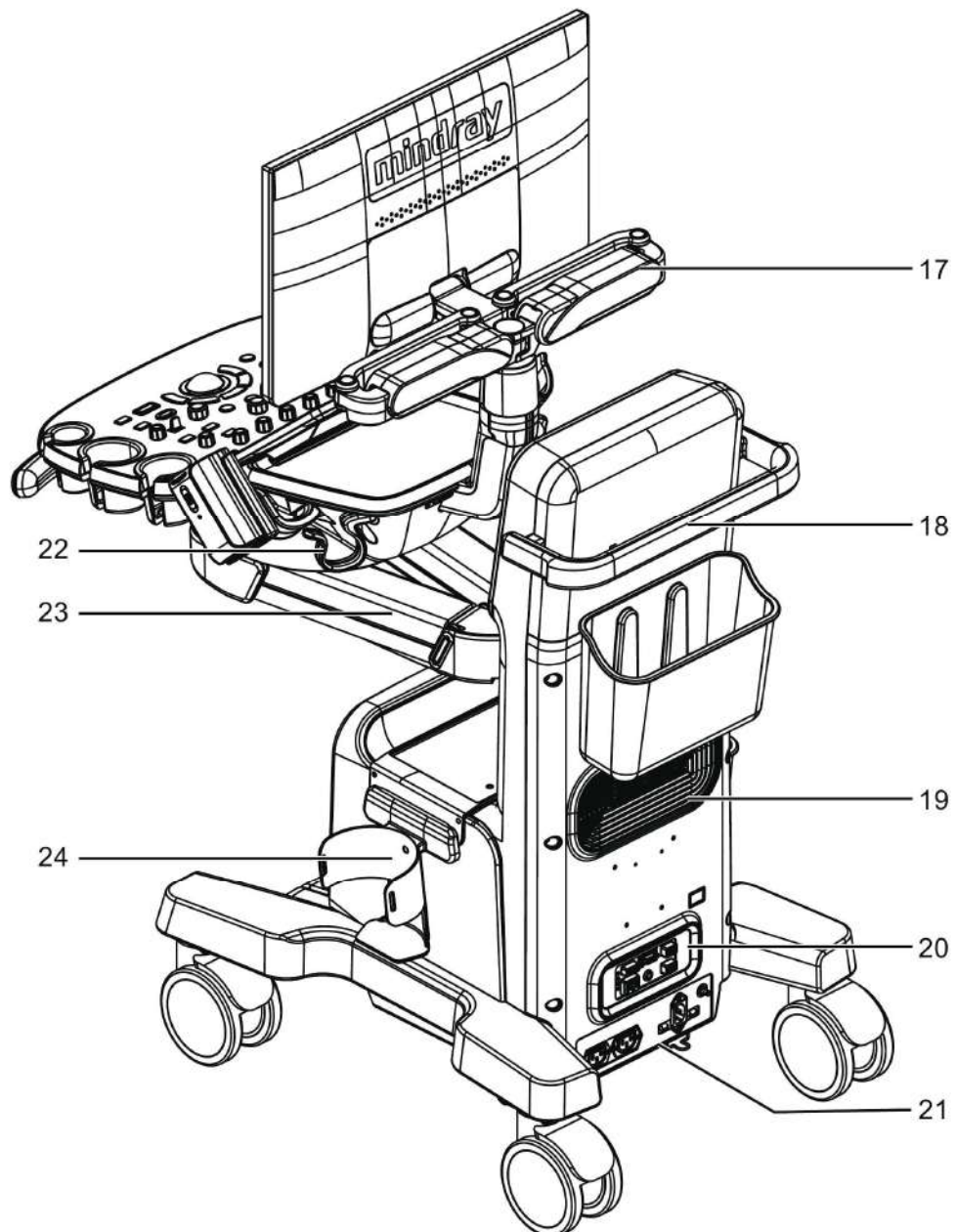

No.	Item	Description
1.	Monitor	Displays the images and parameters during scanning.
2.	Touch Screen	Screen-touching operator-system interface or control.
3.	Ultrasound gel warmer	Used for heating the ultrasound gel.
4.	Transducer& ultrasound gel holder	Used for placing transducers or ultrasound gel temporarily.
5.	Control panel	Key- pressing operator-system interface or control.
6.	Qwerty keyboard	Used for typing characters or entering some functions.

No.	Item	Description
7.	Touch control handle	Holding the right part of the handle to display the battery indicator on the control panel. NOTE: Available only after the battery assembly is configured.
8.	Control panel adjusting lever	Used for lifting or swiveling the control panel.
9.	Central brake	Used for locking the 3 full-lock casters. NOTE: Available only after the central brake is configured.
10.	Caster	With central brake: <ul style="list-style-type: none"> • Press the central brake pedal (used for locking the 3 full-lock casters): press the red pedal of the double-lock caster to lock the system. • Release the • central brake pedal (used for locking the 3 full-lock casters): press the off pedal of the double-lock caster to freely move the system; press the green pedal of the double-lock caster to move the system straight. Without central brake: <ul style="list-style-type: none"> • 3 full-lock casters: press the “ON” pedal to lock the system, and press the “OFF” pedal to move the system. • 1 double-lock caster: press the red pedal to lock the system, press the green pedal to move the system straight, and press the “OFF” pedal to reset the green and red pedals.
11.	Probe port	Sockets connecting transducers and the main unit.
12.	Front I/O panel	Connecting to ECG leads, CW, USB drive, audio input and output etc.
13.	Speaker	Outputs the audio.
14.	Intracavitary probe holder	Used for placing the intracavitary probe.
15.	Placing table	Used for placing the B/W video printer, storage bin, and wipes box bracket.
16.	Storage bin	Used for temporal storage
17.	Monitor support arm	Supports the LCD display and adjusts the position and angle of the LCD display.
18.	Rear handle	Used for pushing and moving the system.
19.	Cooling vent	Used for cooling the main unit.
20.	Back I/O panel	Interface panel used for inputting and outputting signals.
21.	Power supply panel	Electrical port panel.
22.	Hanger	Used for hanging the probe cables.
23.	Control panel support arm	Supports the control panel and adjusts the position of the control panel.
24.	Wipes box bracket	Used for placing the wipes box.