



GLOBAL VALUE DOSSIER
TRI-STAPLE™ TECHNOLOGY &
POWERED STAPLING SYSTEMS

Medtronic
Further, Together

Prepared by: **Jason Davis**
Coreva Scientific
Im Muehlenbruch 1
53639 Koenigswinter, Germany
Phone: +49 76 176 999 422
E-mail: jd@coreva-scientific.com

Version No. 1.0

Date: August 21, 2020

Contents

1. Disclaimer and scope.....	10
1.1. Products and aliases.....	10
1.2. Data sources	10
1.3. Analysis method and disclaimers.....	10
2. Executive summary	12
3. Stapling background and technology	17
3.1. Summary and key messages	17
3.2. Stages of surgery	17
3.3. Surgical stapling history.....	18
3.4. Stapling function	19
3.4.1. Stapling devices.....	20
3.4.2. Staple formation.....	21
3.4.3. Stapler firing sequence.....	23
3.4.4. Cartridge selection and tissue thickness	24
3.4.5. Surgical stapling applications.....	25
3.4.1. Potential complications.....	27
3.5. Stapling and safety.....	29
3.6. Reinforcement of the staple line.....	30
3.6.1. Reinforcement in bariatric procedures.....	31
3.6.2. Reinforcement in pulmonary resections	33
3.6.3. Reinforcement in colorectal anastomoses.....	34
4. Health economics of surgical stapling	36
4.1. Summary and key messages	36
4.2. Health economics of surgery.....	36
4.3. The burden of surgical complications.....	37
4.3.1. Impact of leaks.....	38
4.3.2. Impact of bleeding	44
4.3.3. Impact of other complications	47
4.4. Role of technology in reducing complications.....	50
4.5. Stapling and reducing complications.....	52
5. Tri-Staple™ technology.....	55
5.1. Recent evolution in Medtronic stapling technology.....	55
5.2. Tri-Staple™ technology.....	56
5.3. Specialty reloads	57
5.3.1. Tri-Staple™ technology black reloads.....	57

5.3.2.	Tri-Staple™ technology curved tip reloads.....	58
5.3.3.	Tri-Staple™ technology radial reloads	58
5.3.4.	Tri-Staple™ technology reinforced reload.....	59
5.3.5.	Tri-Staple™ technology 30 mm reloads.....	59
5.4.	Real-world clinical use of Tri-Staple™ technology	60
6.	Tri-Staple™ technology in preclinical and benchtop testing	63
6.1.	Summary and key messages	63
6.2.	Overview	64
6.3.	Experimental investigations of Tri-Staple™ technology.....	64
6.3.1.	Tissue clamping	64
6.3.2.	Stress on vessels in vascular stapling	66
6.3.3.	Proper staple formation	71
6.3.4.	Staple-line security	72
6.3.5.	Tissue perfusion	74
6.3.6.	Firing speed and variable tissue thickness performance.....	75
6.3.7.	Staple-line reinforcement.....	77
7.	Clinical applications of Tri-Staple™ technology.....	79
7.1.	Summary and key messages	79
7.2.	Overview	79
7.3.	Pulmonary	79
7.4.	Gastric	84
7.4.1.	Bariatric and metabolic surgeries.....	84
7.4.2.	Gastrectomy.....	88
7.5.	Colorectal resection.....	90
7.5.1.	Tri-Staple™ technology with reinforced reload	91
7.5.2.	Tri-Staple™ technology with radial reload	91
7.6.	Other surgical areas	94
7.6.1.	Pancreatic	94
7.6.2.	Hepatic.....	98
8.	Powered stapling systems	101
8.1.	Summary and key messages	101
8.2.	Surgical stapling revisited	101
8.3.	Biomechanical benefits of powered stapling.....	102
8.4.	Powered versus manual stapling in clinical applications	105
8.5.	iDrive™ powered stapling system in clinical applications.....	108
8.6.	The Signia™ stapling system.....	111

8.6.1.	Signia™ stapling system technology	111
8.6.2.	Adjusting firing speed	113
8.6.3.	Device usability	114
8.6.4.	The Signia™ stapling system in clinical application	117
9.	Appendices	119
9.1.	Tri-Staple™ technology evidence summary	119
9.2.	Tri-Staple™ technology with reinforced reload evidence summary	121
9.3.	Excluded comparative studies	123
10.	Structured literature search details	125
11.	References	127

List of Tables

Table 3-1	Characteristics of surgical stapling	19
Table 3-2	Stages of stapler firing.....	23
Table 3-3	Example reported tissue thicknesses	24
Table 3-4	Stapler cartridges and corresponding heights.....	25
Table 3-5	Procedures where use of stapling has been reported	26
Table 3-6	Reported surgical stapling complications in bariatric procedures	27
Table 3-7	Reported surgical stapling complications in pulmonary surgeries.....	28
Table 3-8	Reported surgical stapling complications in gastrointestinal resections requiring anastomosis	28
Table 3-9	Methods and materials used in staple-line reinforcement	30
Table 4-1	Suggestions for improving surgical performance of stapling	52
Table 5-1	Reported clinical applications of Tri-Staple™ technology	61
Table 7-1	Parameters and outcomes from single arm laparoscopic colorectal resection with Tri-Staple™ technology with reinforced reload	91
Table 7-2	Devices usually used in rectal resections by surgeon respondents assessing Tri-Staple™ technology with radial reloads.....	93
Table 8-1	Signia™ stapling system components	111
Table 9-1	Tri-Staple™ technology evidence summary	119
Table 9-2	Tri-Staple™ technology with reinforced reload evidence summary	121
Table 9-3	Recovered studies excluded from data analysis	123
Table 10-1	Structured searches in PubMed to identify relevant Tri-Staple™ technology data.....	125

List of Figures

Figure 3-1	Phases of surgery.....	18
Figure 3-2	A history of surgical stapling devices	19
Figure 3-3	Examples of surgical staplers	20
Figure 3-4	Forming staples	21
Figure 3-5	The B shape as an ideal in properly-formed staples	22
Figure 3-6	Illustrations of staple quality scoring.....	23
Figure 3-7	Sleeve gastrectomy leak rates with various methods of staple-line reinforcement.....	31
Figure 3-8	Leak and bleeding rates in gastric bypass and sleeve gastrectomy surgeries.	32
Figure 3-9	Staple-line reinforcement practice in a global survey of bariatric surgeons performing sleeve gastrectomy	33

Figure 3-10	Effect of reinforcement of primary closure in pulmonary resection on prolonged leak rate	34
Figure 4-1	Cost burden of complications in gastrointestinal resections.....	37
Figure 4-2	Length of hospital stay change according to complication grouping for gastrointestinal resection	38
Figure 4-3	Interventions in the management of leaks after bariatric surgery	39
Figure 4-4	Additional time burden due to leaks after bariatric surgery	40
Figure 4-5	Costs associated with scenarios of leak management after sleeve gastrectomy	41
Figure 4-6	Incidence of infection and 30-day readmission after colorectal anastomotic leak	42
Figure 4-7	Hospital length of stay and costs associated with incidence of colorectal anastomotic leak.....	43
Figure 4-8	Cost increases for air leak and other pulmonary complications associated with lobectomy	44
Figure 4-9	Impact of postoperative bleeding after bariatric surgery on resource utilization	45
Figure 4-10	Impact of level of bleeding on hospital resources after pulmonary surgery	46
Figure 4-11	Resource usage after bariatric surgery without and with PONV	47
Figure 4-12	Length of index hospital stay after bariatric surgery without and with PONV .	48
Figure 4-13	Impact of postoperative pancreatic fistula on hospital events	49
Figure 4-14	Difference in length of hospital stay for patients without and with postoperative pancreatic fistula	49
Figure 4-15	Difference in costs for patients without and with postoperative pancreatic fistula.....	50
Figure 4-16	Evaluation of staple-line buttressing impact on sleeve gastrectomy complications in high-risk patients	51
Figure 4-17	Evaluation of staple-line buttressing on sleeve gastrectomy costs in high-risk patients	52
Figure 5-1	A recent history of Medtronic plc stapling technology innovation.....	55
Figure 5-2	Tri-Staple™ technology overview	56
Figure 5-3	Tri-Staple™ technology specialty reloads.....	57
Figure 5-4	Global reports of Tri-Staple™ technology clinical use	60
Figure 6-1	Comparison of pressure exerted by clamping with Tri-Staple™ technology versus Echelon Flex GST™* and Endopath™* cartridges.....	65
Figure 6-2	Comparison of living porcine tissue bruising by clamping with Tri-Staple™ technology versus Echelon Flex GST™*	66
Figure 6-3	Fixed versus pivoting anvil design	67
Figure 6-4	Tension exerted on synthetic vessels during stapling from fixed versus pivoting anvil designs.....	69

Figure 6-5	Tension exerted on synthetic vessels during stapling by Tri-Staple™ technology with curved tip reloads versus Ethicon Powered Vascular Stapler	70
Figure 6-6	Successful staple formation with Tri-Staple™ technology versus single-height staples in a porcine model	71
Figure 6-7	Pulmonary tissue leak rates under in vivo conditions compared between Tri-Staple™ technology and single-height staples	72
Figure 6-8	Leak pressure in stomach excised from patients undergoing sleeve gastrectomy	73
Figure 6-9	Measured vascular volume incorporated in the staple line in Tri-Staple™ technology versus single-height staples	74
Figure 6-10	The impact of stapler firing speed on proper staple formation in tissue of varying thickness	75
Figure 6-11	Impact of stapler compression time and firing rate impact on optimal staple formation	76
Figure 6-12	Comparison of proper staple formation rate between Tri-Staple™ technology alone versus Tri-Staple™ technology with reinforced reload	77
Figure 7-1	Evaluation of staple formation quality in excised pulmonary tissue in patient lobectomy	80
Figure 7-2	Evaluation of staple-line security on patient side of lobectomy	81
Figure 7-3	Tri-Staple™ technology alone versus Tri-Staple™ technology with reinforced reload for complications after pulmonary resection	82
Figure 7-4	Tri-Staple™ technology alone versus Tri-Staple™ technology with reinforced reload for complications after pulmonary resection	83
Figure 7-5	Odds ratios for parameters associated with no postoperative air leak	83
Figure 7-6	Conventional stapler use among risk factors for the development of leak after sleeve gastrectomy	85
Figure 7-7	Comparative analysis of complication incidence of complications after sleeve gastrectomy using Tri-Staple™ technology +/- reinforcement	86
Figure 7-8	Complications after sleeve gastrectomy with oversewing versus Tri-Staple™ technology with reinforced reload	87
Figure 7-9	Tri-Staple™ technology versus Endopath™* in distal gastrectomy	88
Figure 7-10	Tri-Staple™ technology with reinforced reload: complications after distal gastrectomy	90
Figure 7-11	Single-arm evaluation of Tri-Staple™ technology with radial reload for low anterior resection	92
Figure 7-12	Surgeon survey assessing performance of Tri-Staple™ technology with radial reloads	93
Figure 7-13	Sample reports of postoperative pancreatic fistula after distal pancreatectomy	94
Figure 7-14	Sample reports of clinically-relevant postoperative pancreatic fistula after distal pancreatectomy with reinforced staples	96

Figure 7-15	Summary of distal pancreatectomy outcomes comparing Tri-Staple™ +/- reinforcement to other closure methods	97
Figure 7-16	Tri-Staple™ technology versus non-stapled laparoscopic liver resection.....	98
Figure 8-1	Tip displacement during firing with iDrive™ powered stapler versus manual stapler	103
Figure 8-2	Measured forces exerted on the operating hand during iDrive™ powered stapler versus manual stapler firing	104
Figure 8-3	Surgeon scoring of functionality of iDrive™ powered stapler.....	105
Figure 8-4	Operative complications with powered versus manual stapling devices used in pulmonary and bariatric procedures	106
Figure 8-5	Length of stay with powered versus manual stapling devices used in pulmonary and bariatric procedures	106
Figure 8-6	Costs associated with powered versus manual stapling devices used in pulmonary and bariatric procedures	108
Figure 8-7	Hemostatic control in a randomized trial of sleeve gastrectomy with iDrive™ versus Echelon™* stapling systems	109
Figure 8-8	Outcomes after lung volume reduction surgery with the iDrive™ stapling system versus the Endo GIA™ conventional stapler	110
Figure 8-9	Components of the Sigia™ stapling system.....	112
Figure 8-10	Adaptive Firing™ algorithm	113
Figure 8-11	Firing speed adjustment and proper staple formation	114
Figure 8-12	Sigia™ stapling system usability study participant device and practice data	115
Figure 8-13	Select usability assessment post training and simulated surgery	116

1. Disclaimer and scope

1.1. Products and aliases

This document presents a compendium of data regarding technological, experimental, and clinical reports relating to Tri-Staple™ variable height staple technology in both manual and powered (iDrive™ stapling system) or Adaptive Firing™ (Signia™ stapling system) applications. These technologies are used for internal closure during surgical applications including abdominal, gynecologic, pediatric, and thoracic surgery for resection, transection of tissue, and creation of anastomosis. They may also be used for transection and resection of liver substance, hepatic vasculature, and biliary structures, and for transection and resection of pancreas, although this indication is limited to use with certain reloads only. Refer to specific indications indicated in the instructions for use for specialty reloads (30 mm reload, radial reload, black reload, reinforced reload, and curved tip reload). Descriptions of reinforced reloads refer to Tri-Staple™ technology with reinforced reload unless otherwise indicated. Tri-Staple™ technologies include white, tan, purple, and black reloads; purple and black reloads are available with polyglycolic acid felt reinforcement. For comparison, reference may also be made to data or outcomes relating to legacy fixed-height staple technologies (from other manufacturers or legacy Medtronic blue and green cartridge reloads). Note that the focus of the present document is laparoscopic procedures.

Please see the package inset for the complete list of indications, warnings, precautions, and other important medical information relevant to your jurisdiction.

1.2. Data sources

Data informing this document consist of published data (peer-reviewed and conference-presented) identified through publicly available databases (PubMed and EMBASE) and independent review of Medtronic plc data. Where relevant, data from internal test reports were used to supplement published results. Search strings used for public databases are presented in Section 10. Searches were conducted to identify English language literature from the last 10 years on adult patients and included both preclinical/experimental studies and clinical reports. Case studies and veterinary applications were not included for data analysis. Of the results returned, only those presenting data in single-arm or comparative studies that include Tri-Staple™ technology were retained and of the comparative studies, only those with balanced comparisons were retained; staple outcomes compared between powered and non-powered study arms were therefore not included, as the effect of powered staple firing could not be separated from the effect of the staple type or manufacturer (see section 9.3). Additional hand searches were performed for contextual data not focused on the technology for background and other outcomes such as overall incidence of relevant surgical complications and associated costs. Data relating to iDrive™ and Signia™ technologies were noted during analyses of Tri-Staple™ technology searches and otherwise supplied by Medtronic plc. Note that publication details (including year of publication) are indicated according to the PubMed record which defaults to the print publication date. Publication year may therefore differ according to first online availability.

1.3. Analysis method and disclaimers

Clinical results from individual studies are presented as reported (including indication of statistical significance where determined). Where data are amalgamated from multiple reports, please note that the individual studies will vary in terms of design, protocol, other methodological details and, patient population, which may limit conclusions drawn from direct comparison and interpretation of analysis of statistical significance. Determination of statistical significance does not assume clinical significance, which should be determined based on local practice. Note that results determined in experimental or animal models may not directly translate into equivalent outcomes in human patients. Plots are generated from data sources and, unless otherwise indicated, are not images reproduced from source material.

CHAPTER 2

EXECUTIVE SUMMARY

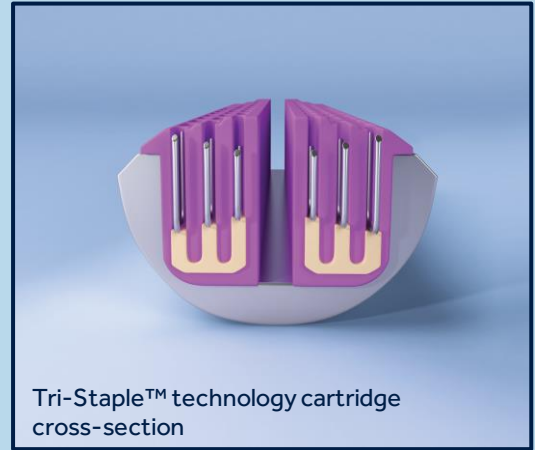

2. Executive summary

Introduction to stapling

Surgery is a critical part of healthcare provision. It often involves the separation or removal of tissue, requiring subsequent approximation of tissue to close the wound. Surgical stapling is one method of closure designed to promote wound healing by helping to maintain hemostasis, to prevent leakage, and to preserve vascularization.¹

Surgical stapling has been in use for over 100 years.² Newer devices add features to improve performance in surgical applications such as redesigned staple technology,³⁻⁶ powered devices to improve staple delivery,⁷⁻⁹ and reinforcement of the staple line.¹⁰⁻¹⁴ Stapling technology has been used in a wide variety of procedures including bariatric surgery,¹⁵ and resections of the lung,^{16,17} gastrointestinal tract,^{1,18} pancreas,^{19,20} and liver.^{21,22}

Complications of stapling

As with any medical procedure, surgical stapling has associated risks. Important adverse events include bleeding, leakage, and stenosis.¹⁵ Incidence varies by surgery type and complication. Leaks can occur in about 1.5%¹¹ to 6%¹⁵ of bariatric procedures, 1.7-15%¹⁶ or 6-26%¹⁷ of pulmonary surgeries, and 1-41% of gastrointestinal resections depending on location.²³ Bleeding requiring intervention or transfusion of blood products may affect 0.6%¹⁴ to about 4%²⁴ of bariatric surgeries and 1-14% of pulmonary resections.²⁵ Stenosis has been reported in 0.1-4% of bariatric surgeries.¹⁵ According to a report by the independent ECRI Institute headquartered in the United States, the overall adverse event rate for surgical stapling is low relative to how often staplers are used.²⁶

Economic burden of stapling complications

Complications can have a serious impact on patient outcomes, including the mortality, and on hospital resource usage in extended hospital stays and increased costs. An analysis in the United States found that for gastrointestinal resections to remove neoplasia, on average 16-30% of per-procedure costs were due to complications.²⁷ Even if the incidence of a complication is low, there can be a considerable overall impact on costs. An analysis of major pulmonary complications after lobectomy for non-small cell lung cancer found an incidence of only 2.9%, yet a more than doubling of direct hospital costs (111% increase).²⁸ An analysis of the effect of leaks after sleeve gastrectomy for the public-payer National Health Service in the United Kingdom suggested increases of 3- to 14-fold above reimbursement.²⁹

Reducing the burden of stapling complications

Modifications to procedures to reduce complication rates therefore have the potential to not only improve patient outcomes but also reduce the economic burden of disease treatment. An analysis of the addition of buttressing to the staple line in high-risk bariatric surgery patients found a significant 15-fold reduction in the incidence of bleeding; correspondingly, there was a 19% reduction in hospital length of stay and a 4% reduction in total overall costs including the additional investment in buttressing material.³⁰ Another study concluded that, considering the cost of reinforcement in relation to the high cost of leaks, in their series, a reduction of leak rate from 1.8% to 1.16% would compensate for the cost of using staple-line reinforcement in all sleeve gastrectomy patients.³¹

To reduce the burden of complications, suggestions from surgical experience have been made to improve surgical stapling performance. Proposed changes to staple technology have included facilitating staple height matching to tissue thickness^{24,32,33} and providing staples with longer leg length to address possible cartridge-tissue thickness mismatch.⁶ Stapler cartridges should exert less force for certain tissues³⁴ and be designed to allow access in narrow or restricted surgical fields.^{5,35} Regulation of how the staples are deployed

is also a consideration, where proposals have suggested allowing for longer compression of tissue and slowing of firing speeds.^{24,32,34} Finally, concerning reinforcement, international surveys of bariatric surgeons suggest 54% use reinforcement regularly³⁶ and 64% at least intermittently.³⁶ One hundred percent (100%) expect reinforcement to reduce bleeding³⁷ and 77% considered buttressing of the staple line an acceptable method.³⁷

Tri-Staple™ technology overview

Tri-Staple™ technology, Medtronic plc, was designed to address many of the unmet needs in current surgical staplers.^{5,6,24,32-35,37} Among the features of Tri-Staple™ technology are two triple rows of varying heights of staples with the design intent of preserving vascularization of the tissue, a fixed anvil design intended to improve stability, and a cartridge face designed to reduce forces on tissue during stapler application. The new features afforded by Tri-Staple™ technology have found successful application in a variety of surgeries including bariatric,³⁸⁻⁴⁰ and resections of the lung,^{4,41,42} stomach,^{43,44} colon,^{35,45} pancreas,⁴⁶⁻⁵² and liver.²²

Specialty Tri-Staple™ technology reloads build on the core features in the form of black cartridges, which contain staples of the maximum height available in the product line^{46,49,53-56}; curved tip reloads with a narrower cartridge profile to reduce the risk of damage to intricate vasculature during stapler introduction^{6,57,58}; a short 30 mm length cartridge where space in the surgical field may be limited⁵⁹⁻⁶¹; and radial reloads with a semicircular cartridge shape to facilitate accessing tissues where articulation with linear cartridge shapes may be non-optimal due to the laparoscopic access port^{62,63} or anatomy.^{35,45} The cartridge reloads for thicker tissue (purple and black) are also available as reinforced reload with Tri-Staple™ technology, with preattached synthetic absorbable buttressing material.

Clinical studies with Tri-Staple™ technology

In clinical studies, Tri-Staple™ technology has demonstrated improved or comparable patient outcomes. Compared to Endo GIA™ staples, Tri-Staple™ technology has been shown to be significantly associated with over 2-fold lower odds of developing a leak after bariatric surgery³⁹ and higher rates of proper staple formation after pulmonary surgery⁴; in the latter study, there were also non-significantly lower rates of air leak and oozing on pressure testing.⁴ Compared to Ethicon Endopath™* staples, Tri-Staple™ technology was associated with non-significantly lower rates of anastomotic complications (4% Tri-Staple™ technology versus 16% Endopath™*) and overall morbidity (26% Tri-Staple™ technology versus 37% Endopath™*) after distal gastrectomy.⁴³ Decreases were also seen in rates of intraoperative bleeding (non-significant) in major liver resections with Tri-Staple™ technology compared to non-staple closure.²² Pooled rates from a brief survey of the literature suggest that the incidence of clinically-relevant postoperative pancreatic fistula (CR-POPF) after distal pancreatectomy may be lower with Tri-Staple™ technology (33 cases of CR-POPF in 176 patients, 18.8%)^{46,49-51} compared to pooled rates for other closure methods that include suture and single-height staples (1,383 cases of CR-POPF in 6,083 patients, 22.7%).^{20,64-66}

Tri-Staple™ technology with reinforced reload

Tri-Staple™ technology with reinforced reload has shown significant and non-significant improvements in clinical outcomes across a range of surgeries compared to non-reinforced staples.^{41,42,44,46,50} In pulmonary resections, reinforced reload compared to bare Tri-Staple™ technology achieved lower rates of postoperative air leak^{41,42} and less need for chest-tube placement.⁴¹ In multivariate analysis, the use of Tri-Staple™ technology with reinforced reload compared to bare Tri-Staple™ technology was the only significant predictor of lower odds of air leak (8.5-fold lower with reinforced reload).⁴¹ Compared to suture reinforced staple lines, reinforced reloads were also significantly associated with less burden of postoperative nausea and vomiting in the form of lower incidence 6h after surgery (18% for

Tri-Staple™ technology with reinforced reload versus 36% with suture oversewing) and shorter duration (8 hours with reinforced reloads versus 17 hours with suture oversewing). Significantly lower incidence of bleeding requiring intervention was observed for Tri-Staple™ technology with reinforced reloads versus non-reinforced Tri-Staple™ technology after gastrectomy (0% versus 12%, respectively), along with non-significantly lower rates of anastomotic leakage (0% versus 3%, respectively) and overall morbidity (8% versus 10%, respectively).⁴⁴ The use of Tri-Staple™ technology with reinforced reload in distal pancreatectomy also saw lower rates of CR-POPF versus non-reinforced Tri-Staple™ technology (16% versus 27%⁵⁰ and 0% versus 18%⁴⁶ respectively). Across identified studies where Tri-Staple™ technology with reinforced reload was used in distal pancreatectomy, the pooled rate of CR-POPF was 26 cases in 253 patients or 10%.^{46-48,50,51}

Powered and intelligent stapling with iDrive™ and Signia™ stapling systems

In addition to the improvements to stapling conferred by Tri-Staple™ technology as noted above, the means by which staples are deployed is also a consideration to address unmet needs. Powered stapling devices such as the Medtronic iDrive™ Ultra powered stapling system and its successor the Signia™ stapling system use push-button operated, battery-powered motors to fire staples through tissue in contrast to the mechanical hand-actuated levers of manual staplers. Retrospective analyses of administrative databases of procedures using staplers (mixed Medtronic and Ethicon devices) suggest that powered devices have achieved significantly lower rates of bleeding and need for transfusion in pulmonary⁶⁷ and bariatric⁶⁸ surgeries compared to manual staplers. A clinical study comparing outcomes between the iDrive™ stapler and an unspecified Echelon™* device reported significantly lower bleeding incidence in a reduced need for hemostatic clips in the iDrive™ stapler group compared to the Echelon™* group (37 of 105 patients, 35% vs. 59 of 102 patients, 58%).⁸

Signia™ stapling system performance

As the next advance in the Medtronic stapler portfolio, the Signia™ stapling system incorporates design features to extend the benefits of powered versus manual staplers and to address additional unmet stapler needs. The Signia™ stapling system senses tissue properties through force sensors in the device and, during compression, can slow down the firing if readings are detected to suggest thicker and/or denser tissue. In conjunction with chip-enabled Tri-Staple™ 2.0 technology, the Signia™ system can make continuous adjustments to the firing speed in real time and provide additional feedback to the user. Studies in animal tissue^{3,69} and clinical experience with the thick tissue of the pancreatic stump^{47,49} have suggested slower firing speeds lead to improved rates of proper staple formation and clinical outcomes. In testing among practitioners, the Signia™ stapling system was rated highly for performing stapling functions one-handed (100%) and providing useful force feedback (97%) during simulated surgeries in porcine models.^a The practitioner pool consisted of surgeons (n=38) from bariatric, colorectal, thoracic, and general surgery disciplines and of nurses (n=50). Participants were not selected based on familiarity with Medtronic/Covidien devices; 54% of nurses and 37% of surgeons had either exclusive experience of Ethicon staplers or both Covidien and Ethicon devices. As the Signia™ stapling system is a newer technology from Medtronic in the stapling portfolio, clinical studies are limited; however, use of the Signia™ system has been reported in case studies

^a Internal study, RE00024826, rev D. Summative usability report, Signia™ stapling system. Testing was performed with multiple cohorts of individual surgeons and paired surgical teams consisting of a surgeon and surgical technician or registered nurse. Participants were recruited via a third party and were paid honoraria by Medtronic plc. Surgery simulated in porcine models during which surgeons completed approximately 281 staple fires of 95 Endo GIA Tri-Staple™ reloads, 91 Tri-Staple™ 2.0 reloads, and 105 Tri-Staple™ 2.0 cartridges.

and series for bariatric surgeries^{70,71} vessel division in fistulectomy,⁷² liver parenchymal transection using Tri-Staple™ technology with curved tip,⁵⁹ and for pericardiotomy and bronchial stump closure during pulmonary bilobectomy.⁷³ Results from an in-progress clinical trial will further add to the body of evidence regarding use of the Signia™ stapling system in patients.

Summary

Surgical stapling continues to be a widely used method of internal wound closure with relatively low rates of complications.²⁶ Still, the efficacy of staplers will be influenced by their proper use, supported by appropriate training with the device. The advent of Tri-Staple™ technology may address some of the unmet needs that have been reported in other forms of staplers available, and the addition of powered, intelligent delivery with the Signia™ stapling system may prove of further benefit to improve surgical performance and patient outcomes.

CHAPTER 3

STAPLING BACKGROUND AND TECHNOLOGY



Tri-Staple™ technology family of reloads

- Surgical application
- Stapling function
- Stapling and safety
- Reinforcement of the staple line

3. Stapling background and technology

3.1. Summary and key messages

- **Stapling is a means of closure used during surgery:** Surgical stapling is one method of approximating tissues, with aims that include preserving adequate tissue vascularization to promote healing, avoiding leakage and fistula formation, and creating an adequate lumen.¹
- **Surgical stapling has been in use for over 100 years:** From the first reports from Hungary in 1908, the development of stapling technology has seen key features retained and others refined to improve patient safety and device performance through continued innovation.²
- **A variety of stapling devices is available:** Stapling devices are available tailored to surgical application, including open, laparoscopic, linear, and circular variants.¹
- **The ideal formed staple shape resembles the letter “B”:** As determined since the earliest stapler designs,² modern staplers consider resemblance to the letter B as a quality measure of proper staple formation.^{34,74}
- **Staple cartridge should be selected according to target tissue thickness:** Tissue thickness varies according to organ³⁴ and even location within organ.^{32,33} Staple reload cartridges are produced with a selection of staple heights to enable matching of staples to expected compressed tissue thickness, and too tall or too short staples for the intended tissue may negatively impact proper staple formation and the resulting staple line integrity.^{32,34}
- **Complications may be associated with stapler use:** Complications of interest that may be associated with the site of closure where tissue is approximated include leak,^{11,24,34} bleeding,^{14,15,75} and stenosis¹⁵ depending on the procedure.
- **Stapling requires proper use for patient safety:** Surgical stapling is a safe and valuable tool in the surgeon’s armamentarium, but requires appropriate training and deployment.^{26,76}
- **Reinforcement with stapling can reduce staple-related complications:** While results vary across surgery types and studies, recent aggregate analyses have suggested that the use of reinforcement material in pulmonary⁷⁷ and bariatric¹¹ surgical procedures may reduce the risk of staple-line associated complications.

3.2. Stages of surgery

Surgery is an important component of many interventions used to treat disease. The surgical process can be broadly divided into four phases: access, dissection, resection (or repair) and closure (Figure 3-1). In the first, access to the internal structures is created by considering position of the patient, making incisions in the skin, and creating exposure of the target organs or tissues, for example using retractors. The tissue on which to be operated must then be mobilized, separating it from the blood supply and internal support structures. Next, the modification or removal of tissues or organs occurs using tools or devices to resect and remove tissue, while also preventing excess loss of body fluids through approximation or other sealing of tissues. Examples here include the use of electrosurgical tools to simultaneously divide and seal blood vessels and thereby reduce blood loss, or the use of staples or suturing (or both) to close off the portion of an organ remaining after resection. Finally, the access initially created is closed by approximating divided tissues to

promote healing. In this chapter, the focus is on the use of stapling devices in the third phase, namely the resection or other repair of internal structures. Where relevant, other closure methods (such as sutures) may also be considered but only in the context of the resection phase of surgery.

Figure 3-1 Phases of surgery

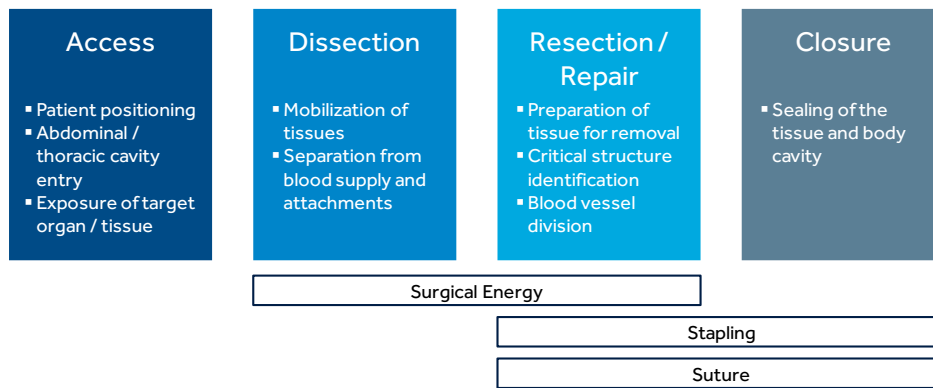

The phases into which a surgical procedure may be broadly divided, spanning the intraoperative period from initial access (skin incision) to final closure. Below the four phases are example methods that may be used, depending on the tissue and the surgical procedure across these phases.

3.3. Surgical stapling history

Stapling has been used as a method of closing internal wounds during surgery for over a century with the first reported use in patients in Hungary in 1908.² From the ground-breaking work of surgeon Hümer Hüttl and surgical instrument designer Victor Fischer, modifications to the original design have been ongoing and can be traced across Europe and the United States (Figure 3-2). Some improvements to the first design have been introduced over the years, including introduction of lighter materials to improve handling and the introduction of disposable cartridges to circumvent early challenges with sterilization. Other features were recognized as important to clinical outcomes and remain features of modern-day staplers, including the use of B-shaped staples to aid in blood flow proximal to the staple line and staggered rows of staples.² This century of development and refinement serves as the foundation for continued innovation that is currently part of the surgical stapling solutions provided by Medtronic plc.

Figure 3-2 A history of surgical stapling devices

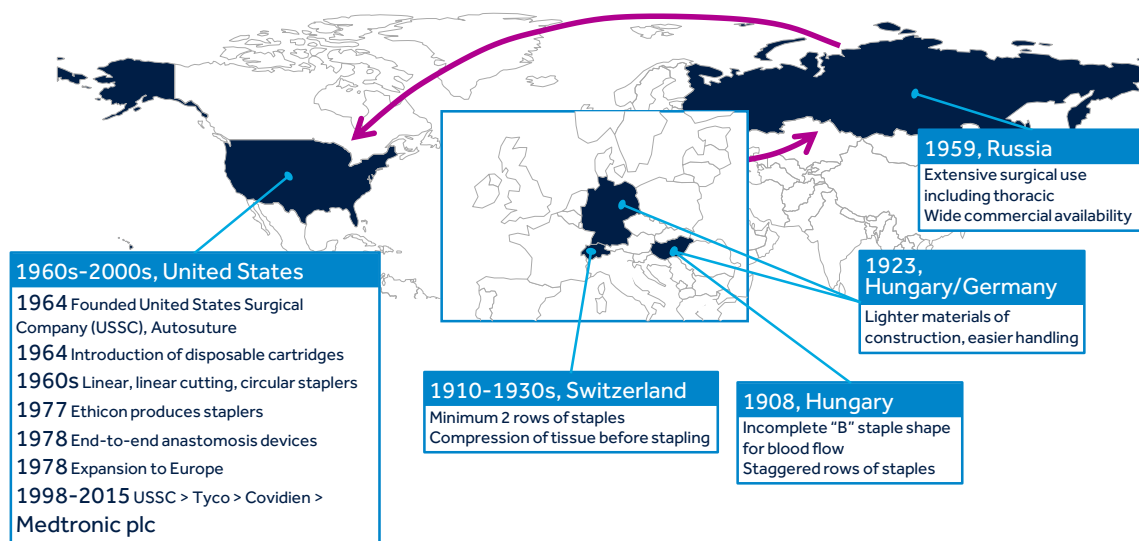

Geographic representation of the history of surgical stapling derived from the review² of Gaidry et al., 2019. USSC, United States Surgical Company.

3.4. Stapling function

As a method of internal tissue approximation/closure, the principles and aims of surgical stapling have remained consistent since their earliest application (Table 3-1).¹ The principles of mechanical stapler operation relate to the function of the device and its interaction with tissues, while the aims consider the desired goals of successfully-stapled tissue to promote patient recovery after surgery. Subsequent subsections describe in greater detail features of stapling that address these design and implementation concepts.

Table 3-1 Characteristics of surgical stapling

Grouping	Details
Principles	Tissue compression
	Tissue stapling using metallic wire as staples
	Configuration of the closed stapled in the shape of a "B"
	Staggered positioning of the staple lines
Aims	Creating an adequate lumen
	Preserving adequate tissue vascularization
	Preventing tension of adapting tissues
	Avoiding leakage and fistula formation
	Providing good hemostasis

Table¹ reproduced from Atlas of upper gastrointestinal and hepato-pancreato-biliary surgery, Surgical staplers chapter, 2016.

3.4.1. Stapling devices

Modern stapling devices come in a variety of forms and functions depending on the surgical application. All share the common feature, however, of the capture of layers of tissue to be approximated between two components of the stapler device. The tissue is compressed, and subsequently staples are driven through the tissue to achieve the approximation. Examples of stapling devices are shown in Figure 3-3.

Figure 3-3 Examples of surgical staplers



Examples of surgical staplers. Each consists of a cartridge housing the staples (colored components) opposing an anvil against which the staples are pushed to reshape them.

3.4.1.1. Linear

A stapling device for open surgical applications delivering 2 or 3 rows of staples. Tissue is compressed between the anvil and the cartridge to create approximation. The tissue after stapling is not cut, instead requiring separate division to remove the tissue partitioned by the staple line.

3.4.1.2. Linear cutting

A surgical stapling device that, like the linear stapler, creates a line of staples in tissue, but in contrast, creates a pair of the 2- or 3-row sets on either side of a knife. During stapling, the tissue is divided along the cut line down the center of the device allowing for separation of the tissue with a separate staple line on either side of the cut. These can be open or laparoscopic.

3.4.1.3. Circular

An endoscopic stapling device used to join structures in an annulus. The cartridge side of the stapler is inserted on one side of the break in the structure to be joined (such as a resected part of the gastrointestinal tract) while the anvil is loaded into the other side. The two components are brought together to achieve compression of the tissue and formation of staples after firing. The stapler also includes a knife that trims tissue around the newly-created staple line.

3.4.1.4. Manual versus powered staplers

The clamping, compression, firing, and cutting (if present) performed by a stapling device can be performed manually with the operating surgeon manipulating buttons and levers to lock, trigger, and release the device. Modern stapling applications may instead use battery-powered devices in which the stapler firing sequence is controlled through push-button operation. Further details are presented in Chapter 8.

3.4.2. Staple formation

Surgical stapling achieves tissue approximation through the deployment of multiple rows of staples. A requirement of this process is the proper formation of the staples after they have penetrated the tissue to be approximated. Staplers vary in design, but a general principle is the use of an anvil to reshape the fine wire staple into the shape required to hold tissue stationary (Figure 3-4). Depending on the stapler design, either the staples in the cartridge remain stationary and the anvil is moved into position during firing, or the anvil is fixed, and the staple cartridge is brought into proximity.

Figure 3-4 Forming staples

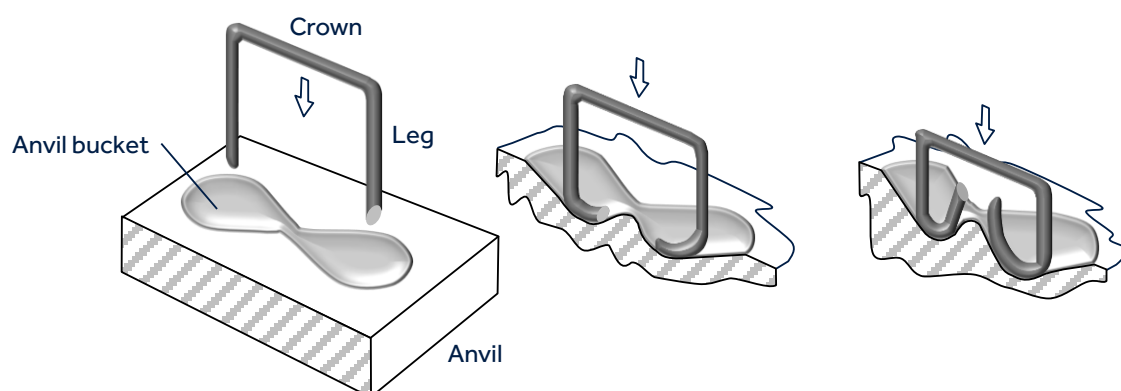

A schematic is shown of a surgical staple meeting the opposing anvil bucket. The legs of the staple are pushed through the tissue and are bent by the wells of the bucket into the final shape. Arrows are for illustration of staple position only; staple formation may be achieved by holding the cartridge with the staples stationary and moving the anvil or fixing the anvil and moving the cartridge holding the staples towards it. Illustration adapted from European patent application EP 0 697 197 A1, application number: 95110415.7.

Achieving the proper B shape, as has been the target since the earliest staple designs,² is considered an essential component of tissue healing.⁶⁹ Examples of fired staples classified as acceptable and unacceptable (according to Medtronic plc standards) are shown in Figure 3-5.

Figure 3-5 The B shape as an ideal in properly-formed staples

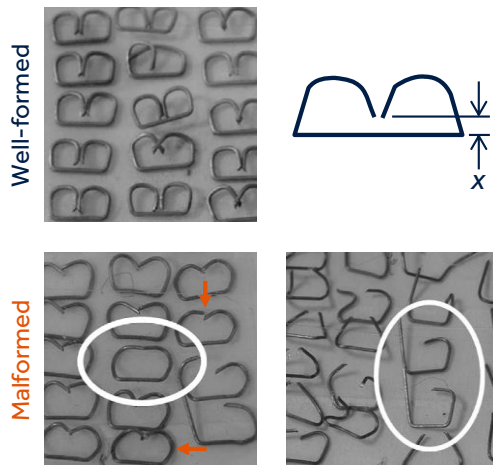

The desired shape after staples have been deployed in tissue is that of the letter “B”. The staples shown were recovered from preclinical testing in porcine stomach performed by Medtronic plc.⁷⁴ White circles of malformed staple examples are as highlighted in the original source, orange arrows indicate malformed examples similar to those appearing among the illustrative examples in an Ethicon-sponsored review of staple formation (Figure 3-6). The variable “x” (upper right panel) illustrates the measure of under crimp serving as a Medtronic plc quality control criterion.

Assessment of proper staple formation relies in part on the judgment of the observer. Caution is thus required when assessing reported rates of proper staple formation, since criteria of what constitutes proper formation may differ from study to study, which in turn will affect the proportion of staples considered correctly formed. A review sponsored by Ethicon depicted schematic illustrations of what would be considered acceptable and unacceptable forms of staples (Figure 3-6).³⁴ This scoring system is consistent with that reported in an independent study that assessed quality of staple formation in porcine stomach using Ethicon staples (gold cartridge) fired with a powered stapling device (Echelon Flex™* powered Endopath™* stapler; see Figure 6-11).⁶⁹ Staples classed as acceptable in the Ethicon-sponsored table (such as acceptable 4 and 8 in Figure 3-6) correspond to examples of what were considered malformed staples in a Medtronic study (orange arrows, Figure 3-5). A broader or more inclusive definition of acceptable staple formation would result in higher reported rates of proper staple formation in studies applying these criteria compared to the application of stricter criteria; studies applying stricter criteria that still demonstrate high proper formation rates may indicate better performance. No study in the present analysis, however, was identified to evaluate the impact of staple formation scoring system on staple quality or preclinical performance outcomes.

Figure 3-6 Illustrations of staple quality scoring

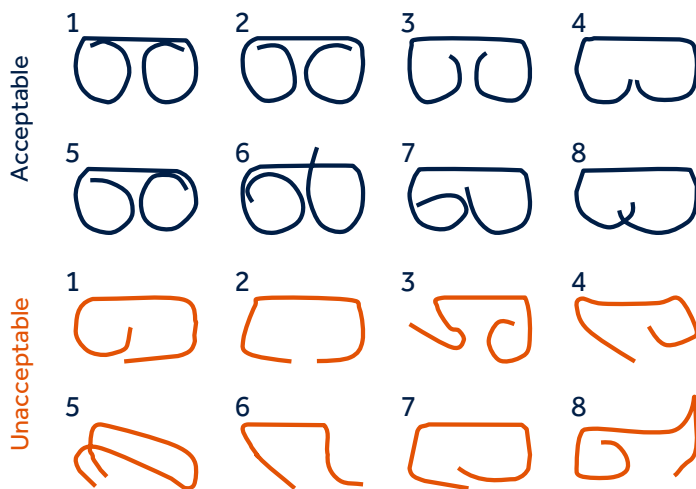

An Ethicon-sponsored review provided illustrations of example staple forms that the study authors would classify as acceptable and unacceptable.³⁴ The numbering of staple forms shown is as indicated in the source publication.

3.4.3. Stapler firing sequence

The process of approximating tissue with a stapling device consists of multiple stages. The exact stages will differ depending on the device, most notably for circular staplers. The following description is applicable to linear (laparoscopic) stapling (Table 3-2).

Table 3-2 Stages of stapler firing

Stage	Description
Grasping	The tissue to be stapled is isolated within the jaws of the stapler, ensuring foreign bodies (clips, clamps, other instruments) and non-targeted tissues (blood vessels not to be sectioned) are excluded.
Compression	The tissue is held within the jaws of the stapler and compressed towards its final thickness, as determined by the closed height of the staples used.
Staple deployment	Staples are fired through the tissue to contact the opposing anvil, forming the B shape through the tissue and approximating the tissue layers.
Cutting (if present)	Stapler designs that include cutting typically incorporate a spatial or temporal lag such that the division of tissue along the cut line should occur only after the rows of staples on either side have been formed.
Retraction	The cutting blade is retracted as tissue remains compressed within the jaws after stapling and division.
Release	The stapling jaws are opened leaving the tissue subject only to compressive forces exerted by the staples. Especially in the case of vascular stapling, the patency of the staple line can be checked before release of any additional clamping or hemostasis that was applied prior to stapling.

3.4.4. Cartridge selection and tissue thickness

Across the various tissues where surgical stapling can be used, the thickness of the tissue to be secured can vary. Even within a single tissue, such as the stomach, tissue thickness varies depending on where in the stomach the measurement is taken.³³ Stapler reload cartridges are available with various stapler heights, which should be matched according to the thickness of the tissue to be stapled, taking into consideration the expected final, compressed thickness. Example reported tissue thicknesses are shown in Table 3-3, however it should be noted that these values are not absolute; they can vary from patient to patient according to factors such as sex³² or with disease conditions that may cause changes such as thickening³⁴ or thinning. Variation is also seen within the same tissue, notably the stomach, where thinner tissue is generally seen at top of the stomach (fundus, cardiac sphincter) with thicker tissues observed in the middle (corpus) and base (antrum, pyloric sphincter).³² In terms of practical application of cartridge selection, even for experienced surgeons, estimation of target tissue thickness can be challenging,⁷⁸ and some advocate for development of an objective laparoscopic measuring device.³³

Table 3-3 Example reported tissue thicknesses

Tissue	Approximate thickness (mm)	Reference
Stomach	Mean 1.6 – 3.1 mm Max 2.2 – 4.5 mm	Chekan 2014, ³⁴
	Male Fundus 1.37 – 2.09 mm (mean 1.74 mm)	Barski 2018, ³²
	Male Corpus 1.98 – 2.60 mm (mean 2.38 mm)	Barski 2018, ³²
	Male Antrum 2.55 – 3.17 mm (mean 2.95 mm)	Barski 2018, ³²
	Female Fundus 1.37 – 1.94 mm (mean 1.66 mm)	Barski 2018, ³²
	Female Corpus 1.98 – 2.64 mm (mean 2.32 mm)	Barski 2018, ³²
	Female Antrum 2.55 – 3.17 mm (mean 2.84 mm)	Barski 2018, ³²
Small intestine	1 – 2 mm	Chekan 2014, ³⁴
Colon	Up to 3 mm	Chekan 2014, ³⁴
Pancreas	15 mm (IQR 12 – 17 mm)	Kim 2016, ⁷⁹
Lung	Cadaveric, under compression Range: 1.5 mm (anterior) – 9.0 mm (posterior) Mean 4.1 mm (peripheral) – mean 5.9 mm (central) Tissues 3.0 mm thicker in females	Chekan 2016, ⁸⁰

Note that the means indicated in the above table for stomach wall thickness from Barski et al., 2018 are averages taken across four studies that reported thickness measurements. The indicated ranges (maximum, minimum) were determined from these summary data. IQR, interquartile range.

To address the need of matching cartridge to target tissue thickness, manufacturers provide a range of products with varying staple heights. Examples of available stapler cartridges and the corresponding open staple heights are listed in Table 3-4.³² The ranges of closed staple heights shown for the Tri-Staple™ technology are due to the multiple rows of

staples of varying height; in contrast, the Ethicon products correspond to a single staple height. In selecting a cartridge during an operation, the Ethicon range provides more options, but may require surgeons to resolve differences of 0.3 mm (difference in closed staple heights ranging from blue to black), and as has been noted, estimating tissue thicknesses can be challenging.^{6,78}

Table 3-4 Stapler cartridges and corresponding heights

Tissue	Medtronic (Tri-Staple)	Ethicon
Thin – mesentery	Gray (0.75 mm – 1.00 mm)	White (1.0 mm)
Thin – vascular	Tan (0.88 mm – 1.88 mm)	
Medium		Blue (1.5 mm)
Medium-thick	Purple (1.50 mm – 2.25 mm)	Gold (1.8 mm)
Thick		Green (2.0 mm)
Extra-thick	Black (2.25 mm – 3.00 mm)	Black (2.3 mm)

Measurements taken from Tri-Staple™ 2.0 technology instructions for use (Tri-Staple) and from Ethicon promotional materials.

While tissue thickness is an important consideration for staple cartridge selection, the tissue composition (notably its compressibility) must also be taken into account.³⁴ For example, in pulmonary resection, tissue to be stapled that is more peripheral in the lung consists of more air than solid components and may thus require less compression force and duration (recall stapling firing sequence, Table 3-2).³⁴ In contrast, lung tissue that is more central is firmer (comprised of more blood and cartilage in the bronchi) and thus may require longer to achieve adequate compression.³⁴

3.4.5. Surgical stapling applications

Uses of surgical stapling in the clinical context include resection (removal of part of an organ), transection (cutting through an organ or tissue), or anastomosis (joining cut or divided structures to create a connection).^b Procedures for which stapling use has been approved include abdominal (including the gastrointestinal tract), gynecologic, pediatric and thoracic surgery for resection, transection of tissue and creation of anastomosis, as well as procedures involving liver, pancreas, and vasculature. A non-exclusive list of example procedures where stapling has been used is shown in Table 3-5.

^b United States Food and Drug Administration, “Surgical Staplers and Staples” web page, <https://www.fda.gov/medical-devices/general-hospital-devices-and-supplies/surgical-staplers-and-staples>. Published June 26, 2019. Content current as of June 25, 2019. Accessed Feb. 15, 2020.

Table 3-5 Procedures where use of stapling has been reported

Organ system	Procedure
Esophagus	Esophagectomy ¹
	Diverticulectomy ¹
Stomach	Gastrectomy ¹
	Bariatric (Roux-en-Y gastric bypass) ⁴⁰
	Bariatric (Sleeve gastrectomy) ⁴⁰
	Bariatric (One anastomosis gastric bypass) ⁸¹
	Bariatric (Single anastomosis duodeno-ileal bypass with sleeve gastrectomy) ⁸²
Lower gastrointestinal tract	Colon resection ¹
	Rectal resection ¹
	Anterior resection ¹⁸
Pancreas	Distal Pancreatectomy ⁵⁰
	Pancreaticoduodenectomy ⁸³
Liver	Hepatic resection (parenchyma) ²¹
	Hepatic resection (vasculature) ²¹
Spleen	Splenectomy ⁸⁴
Gallbladder	Cholecystectomy ⁸⁵
Appendix	Appendectomy ⁸⁶
Lung	Pulmonary resection (lung parenchyma) ⁸⁷
	Bronchial division ⁸⁷
	Pulmonary vessel dissection ⁸⁷
Uterus	Radical hysterectomy ⁸⁸
	Cornual resection ⁸⁹

References shown indicate example reports where the indicated procedure has been reported to use surgical stapling. It is not exhaustive, nor indication of prominence or approved indication of the use of stapling in the procedure shown.

3.4.1. Potential complications

As with any surgical procedure, internal closure of dissected tissue may result in unintended adverse events or complications. In studies of surgical staplers, the relevant complications considered depend in part on the procedure, although some are specifically related to the staple line and thus are applicable for multiple procedures. Examples of complications that have been reported in connection with the use of surgical staplers (even when not directly caused by the stapler or staple line) and estimated incidence are shown for bariatric procedures (Table 3-6), pulmonary procedures (Table 3-7) and gastrointestinal resections requiring creation of anastomoses (Table 3-8).

Table 3-6 Reported surgical stapling complications in bariatric procedures

Complication	Procedure	N	Rate	Reference	Notes
Postoperative bleeding	SG	98,142	0.63% overall; 0.55 – 0.80% depending on reinf	Zafar 2018, ¹⁴	Defined as bleeding within 72h of operation requiring transfusion or unplanned procedure for the purpose of "bleeding"
	SG	1,261	2.10%	Bransen 2015, ⁷⁵	Netherlands; POB requiring additional procedure to manage
	SG	NR	0 – 20%	Silecchia 2018, ¹⁵	Reoperation rate 1.4%
	RYGB	NR	1.3 – 3.1%	Silecchia 2018, ¹⁵	Review article
	OAGB	NR	0.2 – 28.6%	Silecchia 2018, ¹⁵	Review article
Bleeding (unspecified)	RYGB	NR	1.9 – 4.4%	Acquafresca 2015, ²⁴	Literature review
Leak (circular stapler)	RYGB	1,074 - 2,606	0.4% – 2.5%	Chekan 2014, ³⁴	Review article
Staple line leak	SG	40,653	1.5% overall; 0.7% (reinf) – 1.9% (no reinf)	Gagner 2020, ¹¹	Systematic review and meta-analysis
	SG	1,261	2.50%	Bransen 2015, ⁷⁵	Netherlands
	RYGB	NR	0 – 5.6% (68% of which at GJA)	Acquafresca 2015, ²⁴	Literature review
	SG	NR	1.1 – 5.3%	Silecchia 2018, ¹⁵	Review article
	RYGB	NR	0.1 – 5.8%	Silecchia 2018, ¹⁵	Review article
	OAGB	NR	0.8 – 1.6%	Silecchia 2018, ¹⁵	Review article
Stenosis	SG	NR	0.7 – 4.0%	Silecchia 2018, ¹⁵	Review article
	RYGB	NR	3 – 28%	Silecchia 2018, ¹⁵	Review article
	OAGB	NR	0.1 – 1.0%	Silecchia 2018, ¹⁵	Review article

GJA, gastrojejunal anastomosis; N, number of patients informing the indicated rate; NR, not reported; OAGB, one-anastomosis gastric bypass; POB, postoperative bleeding; reinf, reinforcement; RYGB, Roux-en-Y gastric bypass; SG, sleeve gastrectomy

Table 3-7 Reported surgical stapling complications in pulmonary surgeries

Complication	Procedure	N	Rate	Reference	Notes
Prolonged air leak	VATS PR	493	10.8% this study 6 – 26% literature	Pan 2019, ¹⁷	Meta-analysis
	Lobectomy Segmentectomy Partial resection	60	1.7% this study 7 – 15% literature	Ito 2018, ¹⁶	Prospective observational study
Bleeding requiring blood products	Lobectomy Segmentectomy	21,429	1% significant bleeding 14% any bleeding	Ghosh 2016, ²⁵	Hospital administration database analysis
AE during vascular stapling	VATS PR	842 - 2,548	0.10 – 0.27%	Subotic 2019, ⁶	Vascular AE during vascular stapling
Any vascular AE during VATS	VATS PR	414 - 3,076	2.2 – 4.1%	Subotic 2019, ⁶	Vascular AE during all VATS. Includes stapling failure, oozing, laceration of adjacent vessels, technical vascular injury at insertion, rupture of stapling stump. Contributors include tissue fragility, stapler rocking during stapling, stapler-tissue thickness mismatch.
Bronchopleural fistula	Bronchial resection	NR	2.0 – 5.2% (stapling) vs. 6.6 – 18.2% (suturing)	Subotic 2019, ⁶	Review article

AE, adverse event; N, number of patients informing the indicated rate; PR, pulmonary resection; VATS, video-assisted thoracic surgery. The range of reported rates shown for Pan¹⁷ et al. 2019 and Ito¹⁶ et al., 2018 were as reported as general observations in the introductions of the corresponding publications.

Table 3-8 Reported surgical stapling complications in gastrointestinal resections requiring anastomosis

Complication	Procedure	N	Rate	Reference	Notes
Leak (circular stapler)	Colorectal anastomosis	170	10.0%	Chekan 2014, ³⁴	Review article
	Colorectal anastomosis	NR	1 – 24%	Shogan 2013, ⁹⁰	Review article
Anastomotic leak	GI resection	NR	Esophagus: 2% – 16%; Stomach: 1% – 9%; Pancreas: 9% – 16%; Bile ducts: 10% – 16%; Small intestine: 1% – 3%; Colon: 3% – 29%; Rectum: 8% – 41%	Turrentine 2015, ²³	Review article

Leak rates shown for the study of Turrentine et al., 2015 are given according to the location of anastomosis and do not indicate method(s) of creation of the anastomosis. GI, gastrointestinal; NR, not reported

Although the rates for some complications are low, the clinical impact of their occurrence can be devastating. Leaks around resected segments of the gastrointestinal tract, whether for bariatric surgery or colorectal anastomosis, have been described as the most serious and feared of surgical complications.^{13,78,90,91} Bleeding has been similarly described.²⁴ In bariatric procedures, leak-associated mortality after gastric bypass has been reported to be 14.7–17% and around 9% after sleeve gastrectomy.⁹² In low anterior resection, a postoperative anastomotic leak can lead to pelvic sepsis, permanent stoma, or mortality.⁹⁰ Another study examining results from a claims database of colorectal surgery anastomotic leaks (99,879 patients of whom 6,174 experienced a postoperative anastomotic leak within 30 days of operation) noted significantly higher rates of readmission (29% versus 13%, $p < 0.001$) and postoperative infection (27% versus 9%, $p < 0.001$) for patients who experienced leaks compared to those who did not.⁹³

Considerable consequences are not restricted to the gastrointestinal tract. Leaks are also a concern in pulmonary resection under certain conditions. Most air leaks will spontaneously resolve within 5 days of the operation.⁹⁴ If the air leak persists, it is considered a prolonged air leak (often defined as a leak lasting longer than 5 or 7 days) and these are associated with poor patient outcomes.^{77,95} Such an occurrence requires placement of a chest tube causing pain, reduced mobility (thereby increasing risk of deep vein thrombosis), an increased need for mechanical ventilation and risk of reoperation, higher readmission rates to intensive care units, and prolonged hospital stay.⁹⁵

3.5. Stapling and safety

Surgical stapling, through its long history and expanding use, has demonstrated its utility in the armamentarium of sealing tools available to surgeons.^{2,76} As with all surgical techniques, stapling is not without risks. Adverse events and/or complications associated with stapler use have included hemorrhaging, tissue damage, failed anastomoses, and other forms of harm.²⁶ Due to the seriousness and increasing occurrence of these adverse events, the independent ECRI Institute (headquartered in the United States with regional offices in Europe, the Middle East and Asia) has ranked surgical staplers the top of 10 hazards on their annual list for the year 2020.²⁶ An analysis was published by the Food and Drug Administration (FDA) in the United States in 2019 assessing 109,997 stapler incidents since 2011 including 412 deaths, 11,181 serious injuries and 98,404 stapler malfunctions.²⁶ The institute notes that across the reported incidents, the stapler itself was found to function as expected.²⁶ An estimate reported in 2013 suggested a stapler malfunction rate of 0.003% by combining the number of reported malfunctions with an estimate of stapler cartridges using available data from the two primary manufacturers in the United States (Medtronic plc and Ethicon).⁹⁶ Extrapolation of this estimate of cartridge number, and assuming growth from 2011 in stapler use of 0% to 5%, the FDA report of 98,404 incidents over this period would constitute a malfunction rate of up to 0.4%.^{26,96} Available data therefore suggest the device failure rate to be low. Instead, errors occur largely due to inappropriate use (such as selection of a stapler cartridge unsuitable for the target tissue), lack of familiarity with the technology, or erroneous deployment during a procedure.²⁶ Emphasis is placed on following the instructions for use supplied with each device and coordination of device-specific training by manufacturers or experienced super-users, especially if there is to be a change in manufacturer of the devices to be used at the institution.

3.6. Reinforcement of the staple line

Given concerns about complications that may arise around the staple line such as leak or bleeding (see section 3.4.1) various methods of reinforcing the staple line have been investigated.¹⁰⁻¹⁴ These include non-absorbable to fully-absorbable materials and their application during stapling to incorporate them into the staple line, or after the staple line has been created (Table 3-9). Note that depending on the type of reinforcement, additional consideration may be required concerning its impact on cartridge selection (see section 3.4.4). Buttressing materials, for example, will add to the estimated tissue thickness since the material may be added to the cartridge face, the anvil, or both, and cartridge size may need to be accordingly adjusted.

The usefulness of reinforcement or buttressing remains, however, under investigation with some studies showing a benefit while others show none.¹⁴ In the context of sleeve gastrectomy, one group has suggested that the issue may be partly addressed by selective rather than routine use of reinforcement to reduce postoperative bleeding.¹⁴ They noted that bleeding was more common in “high risk” patients (those with comorbidities of hypertension, a history of renal insufficiency, or use of anticoagulant medication prior to surgery) and that future studies may be designed with sufficient statistical power to assess the selective benefit of reinforcement in these patients.¹⁴

Table 3-9 Methods and materials used in staple-line reinforcement

Application	Source	Reinforcement
Extrinsic	Synthetic	Suture (absorbable or non-absorbable)
		Fibrin sealant (absorbable)
Intrinsic	Tissue-derived	Bovine pericardial strips (semiabsorbable)
		Porcine small intestine submucosa (semiabsorbable)
	Synthetic	Expanded polytetrafluoroethane (ePTFE) (non-absorbable)
		Polyglycolic acid mesh (absorbable)
		Alginate (absorbable)

Use of the above materials varies according to surgery type. Each has had clinical application in at least one of bariatric, pulmonary, or colorectal anastomosis procedures.^{11,13,14}

To address the question of utility of reinforcement, aggregate analyses (systematic reviews or meta-analyses) of patient outcomes with or without reinforcement were searched among the three main surgical areas of surgical stapling considered in the present dossier: stomach/bariatric, colorectal resection, and pulmonary resection.

3.6.1. Reinforcement in bariatric procedures

More data are available regarding staple-line reinforcement in sleeve gastrectomy, where individual benefits of different types of reinforcement have been compared. Not all methods of reinforcement add benefit. A meta-analysis of randomized controlled trials comparing outcomes of bleeding, leak, and overall complications in laparoscopic sleeve gastrectomy found no significant differences between patients with staple-line suture reinforcement compared to those without; however, the authors did note a significant increase in operative time when using suture reinforcement.¹⁰ A more comprehensive analysis of a variety of reinforcement methods (including no reinforcement) has also been performed in which differences have been observed (Figure 3-7).¹¹ The analysis comprising 148 investigations and 40,653 patients found significantly lower leak rates after sleeve gastrectomy using an absorbable mesh to reinforce the staple line when compared to glue, bovine pericardial strips, suturing, or no reinforcement.¹¹

Figure 3-7 Sleeve gastrectomy leak rates with various methods of staple-line reinforcement

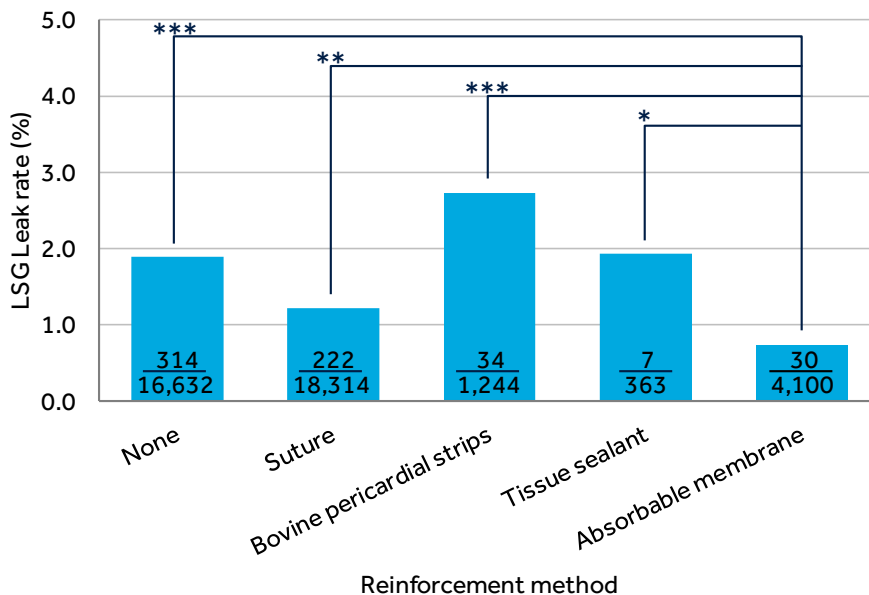

Leak rates determined by systematic review of 148 studies comprising 40,653 patients are shown according to method of staple line reinforcement.¹¹ The vertical axis indicates the leak rate as a percentage, and the numbers superimposed on the bars show the number of patients with leaks over the total number of patients in the corresponding group. LSG, laparoscopic sleeve gastrectomy. * $p < 0.05$, ** $p < 0.01$, *** $p < 0.001$.

An earlier meta-analysis was also conducted that considered leak and bleeding rates for both sleeve gastrectomy and gastric bypass.⁹⁷ This analysis considered only suture, glycolide copolymer (SeamGuard™*), and bovine pericardium (Peristrips™*) in comparison to no reinforcement. For all comparisons, leak and bleeding rates showed the highest incidence in the cohort that had no reinforcement of the staple line, while other methods of reinforcement demonstrated significant reductions (Figure 3-8). In the description of the study protocol, the authors did not specify whether the bleeding data extracted related to intraoperative staple line bleeding or postoperative bleeding or both.

Figure 3-8 Leak and bleeding rates in gastric bypass and sleeve gastrectomy surgeries

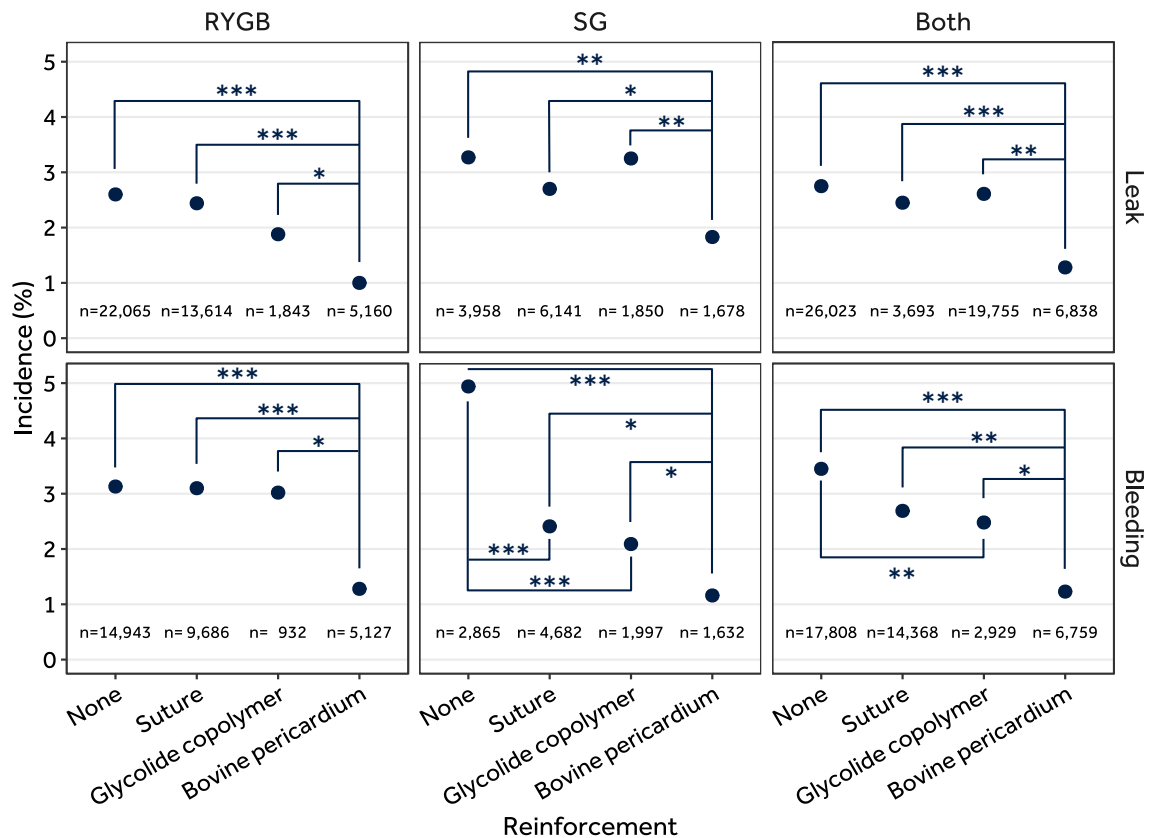

The results from a meta-analysis by Shikora et al., 2015 are shown reporting complication rates associated with stapling in bariatric procedures for leak and bleeding.⁹⁷ Numbers below each point indicate the number of patients contributing to the determination of each complication rate. Note that the authors did not specify the nature of bleeding (postoperative or intraoperative staple line bleeding) in the study protocol. * $p \leq 0.05$, ** $p < 0.01$, *** $p < 0.001$. RYGB, Roux-en-Y gastric bypass; SG, sleeve gastrectomy.

Despite mixed results regarding its effectiveness, reinforcement of the staple line in sleeve gastrectomy is a common practice among bariatric surgeons.³⁶ A global survey encompassing perioperative practices of 863 bariatric surgeons who perform sleeve gastrectomy representing 67 countries found the majority (58% to 61%) use some form of reinforcement and 54% of respondents use reinforcement routinely (Figure 3-9).³⁶

Figure 3-9 Staple-line reinforcement practice in a global survey of bariatric surgeons performing sleeve gastrectomy

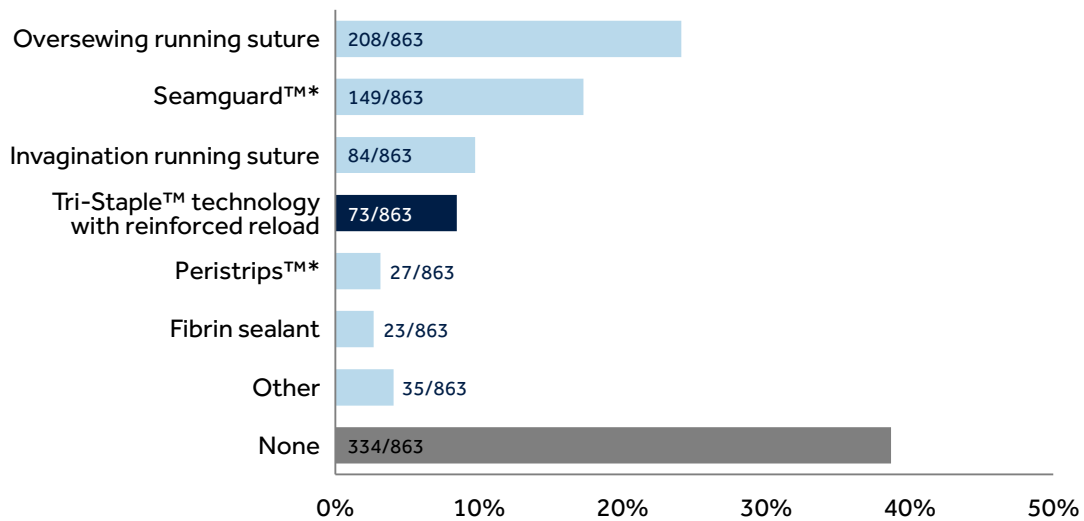

The results from the study of Adil et al., 2020 are shown, which was a global survey of 863 bariatric surgeons performing sleeve gastrectomy.³⁶ Reinforcement methods are as indicated in the publication (including Medtronic Tri-Staple™ technology with reinforced reload, highlighted) and authors noted that respondents were permitted to indicate multiple methods (percentages thus add to greater than 100%). As 39% of respondents indicated using no reinforcement, which does not exclude occasional use of some reinforcement, at least 61% of surgeons are expected to use some form of reinforcement for some procedures.

3.6.2. Reinforcement in pulmonary resections

A single meta-analysis was identified investigating the impact of buttressing in pulmonary resections (lobectomies and wedge resections) on the incidence of prolonged air leak (leak lasting longer than 7 days).⁷⁷ The study is from 2010, however, and therefore only includes data from 2009 and earlier, which may not reflect current reinforcement materials available. Furthermore, the studies included were randomized controlled trials of reinforcement (glue, collagen patch, or staple line buttress) versus corresponding controls that could be suture or staple without reinforcement. Nevertheless, results suggest that the use of reinforcement material in addition to the primary closure method of suture or staple may reduce the incidence of prolonged air leak after pulmonary resection (Figure 3-10). In subgroup analyses, significant reductions were also seen for fibrin glue and for staple line buttressing (buttressing materials and methods were not described). The authors indicated the potential for publication bias, though, and suggest caution in interpretation of results.⁷⁷

Figure 3-10 Effect of reinforcement of primary closure in pulmonary resection on prolonged leak rate

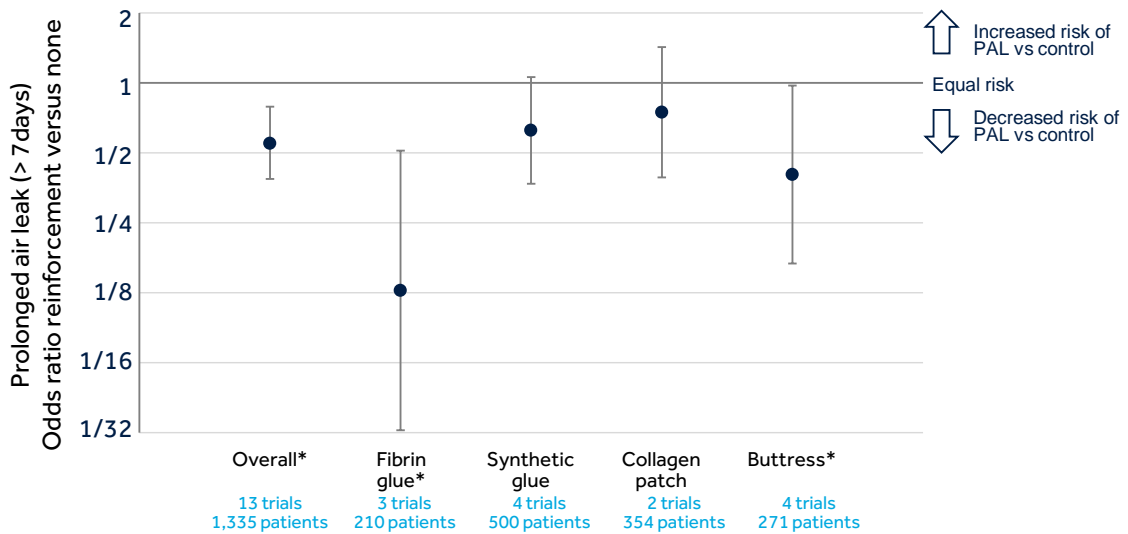

PAL: Prolonged air leak (> 7 days)
 Control: non-reinforced suture or staple pulmonary surgery
 * p < 0.05

Data are shown from the study⁷⁷ of Malapert et al., 2010. The odds ratios plotted indicate the odds of prolonged air leak with the corresponding reinforcement method versus the control (no reinforcement). Error bars correspond to 95% confidence intervals. Specific composition of buttressing materials of the staple line were not provided.

3.6.3. Reinforcement in colorectal anastomoses

Of the procedural areas under consideration, only a single meta-analysis was identified for colorectal anastomoses.⁹⁸ The authors of this study (in Russian) noted, however, that with the limited data available (total 493 patients from 4 original publications) results were not conclusive, and there were suggestions of significant and non-significant effects on reduction of leak rate with reinforcement.⁹⁸

CHAPTER 4

HEALTH ECONOMICS OF SURGICAL STAPLING

- Health economics of surgery
- The burden of surgical complications
- Role of technology in reducing complications

4. Health economics of surgical stapling

4.1. Summary and key messages

- **Economic evaluation characterizes the impact of interventions:** Assigning costs to interventions informs decisions regarding the impact of changing processes, whether to decrease costs related to surgery or increase investment to improve outcomes of interest.⁹⁹
- **Complications contribute considerably to costs:** Analysis of average annual costs per procedure for gastrointestinal resections to remove neoplasia in the United States found that a considerable percentage of costs was due to management of complications.²⁷ These ranged from 16% of \$22,800 for colonic resection to 30% of \$60,000 for esophageal resection.²⁷
- **Rare events can contribute to burden:** A study of pulmonary surgeries noted that although major pulmonary complications (excluding prolonged air leak and pneumonia) occurred in only 2.9% of patients, mean per-patient hospital costs were more than doubled compared to uncomplicated procedures.²⁸
- **Investing in reducing the leak rate can be a cost benefit:** Studies in bariatric surgery have suggested that across an entire cohort, the additional cost of intervention to reduce leak rates is justified, despite rates that were already under 2%.^{30,31}
- **Minor complications can have a substantial care burden:** After bariatric surgery, nausea and vomiting have shown increased length of stay of 79% to 100% and increased risk of 30-day emergency room visits and readmission.¹⁰⁰
- **Minor pulmonary complications increased costs by more than one third:** Such complications after lobectomy increased costs by a factor of 1.31 compared to uncomplicated procedures.²⁸
- **Preventative measures against complications can reduce costs:** Despite variable results regarding efficacy of staple line reinforcement in bariatric surgery,^{11,14} studies have suggested benefit in routine reinforcement compared to costs of treating complications.^{30,31}

4.2. Health economics of surgery

The goal of surgical intervention is the improvement of patient health. Decision-making around surgical procedures may be influenced by multiple factors including risks, benefits, costs, and discussions between patients and providers. Health-economic analyses may consider any or all these factors to quantitatively inform decisions to best deploy available resources.⁹⁹ While cost savings are a common and understandable goal, they cannot always be combined with optimized care. To consider both costs and outcomes, cost-effectiveness analysis was developed to quantitatively compare interventions. Such analysis provides a cost per improved outcome, for example the cost per adverse event avoided. It is therefore important to consider the difference in costs between interventions relative to the expected difference in outcomes.⁹⁹ Decision-makers may thereby decide that a nominally more expensive intervention still represents best value based on its expected benefits.

Taking these considerations into account, the following sections provide a sampling of reports regarding the impact of adverse events or complications in surgical procedures where stapling may be indicated. Of interest are the economic outcomes, whether reported

as currency, resource unit changes (such as length of stay) or expressed as a change relative to a non-complicated procedure.

4.3. The burden of surgical complications

Complications, whether they occur during surgery or postsurgically, have the potential to add considerably to medical costs.²⁷ This cost increase was illustrated in a study²⁷ of gastrointestinal resections for neoplasia from a claims database in the United States, examining the results of 293,967 procedures from 2001–2014. The additional burden was determined according to the type of resection (esophageal, gastric, colonic, hepatic, pancreatic, or rectal) and the class of complication. When considering the average annual cost per patient, a considerable percentage was attributable to costs for managing complications (Figure 4-1). Complication groupings included mechanical wound (e.g., seroma, hematoma, persistent postoperative fistula), infection (e.g., wound or skin infections, and sepsis), urinary (e.g., urinary tract infection), pulmonary (e.g., ventilator associated pneumonia, and iatrogenic pneumothorax), gastrointestinal complications (e.g., postoperative nausea/vomiting and small bowel obstruction), cardiovascular (e.g., deep vein thrombosis, pulmonary embolism, stroke), systemic (e.g., shock), and surgical (e.g., accidental puncture or laceration and hemorrhage/bleeding).

Figure 4-1 Cost burden of complications in gastrointestinal resections

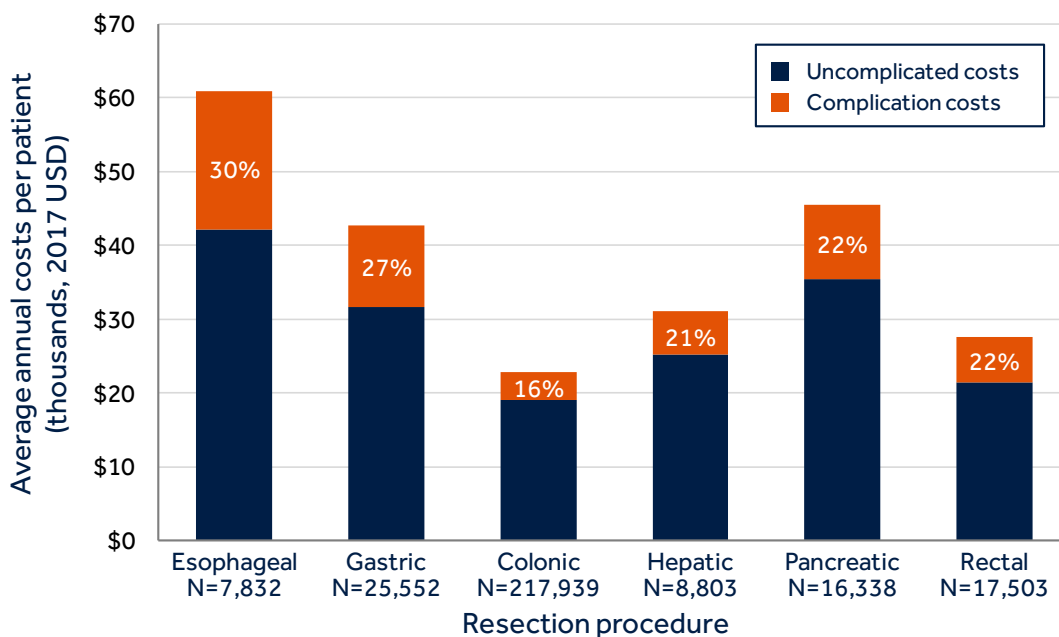

Average annual costs are shown per patient over the period from 2001-2014. The height of each bar indicates the total average cost while the overlaid segment in orange indicates the proportion of the total attributable to complications. Counts below each bar indicate the number of patients treated over the data period of 14 years (total 293,967 patients). These patients represent 1,408,711 weighted patients nationwide.²⁷ Costs were determined by taking the reported average annual cost (total uncomplicated and complicated costs) and dividing by the average number of weighted patients per year. USD, United States dollars.

Complications associated with neoplastic resection may also incur quantifiable burden in terms of increased mortality and length of stay (Figure 4-2).²⁷ All complications, aside from gastrointestinal and mechanical wound (not shown), were associated with a significant increase in the risk of in-hospital mortality, from 2-fold (surgical complications) to 8.6-fold (infectious). Hospital length of stay was increased across all groups of complications, from 83% longer for surgical complications to 6.5 times longer for infectious complications.²⁷

Figure 4-2 Length of hospital stay change according to complication grouping for gastrointestinal resection

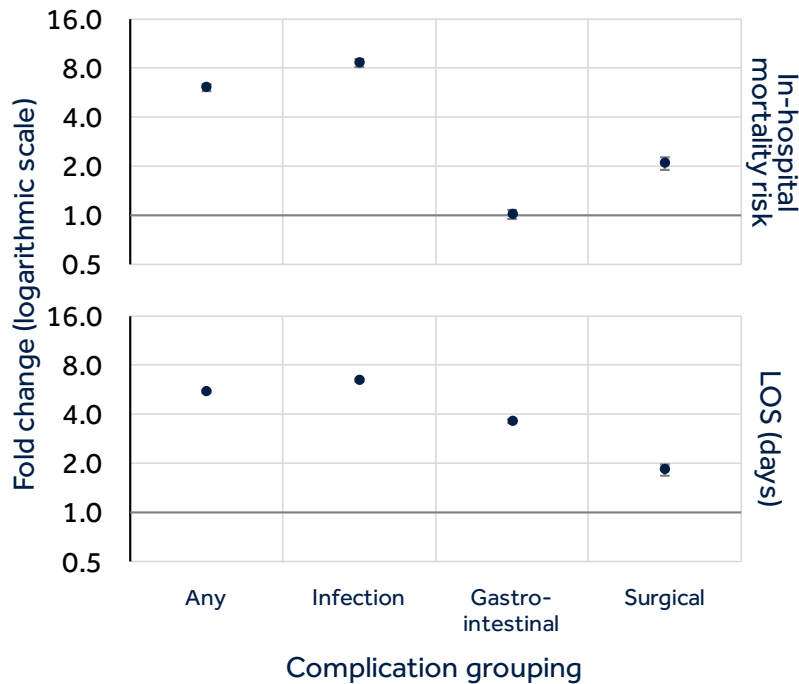

Factor changes in mortality (top) and hospital length of stay (LOS in days, bottom) are shown according to the complication groupings as reported²⁷ in Zogg et al., 2018. Infection complications include wound or skin infections and sepsis; gastrointestinal complications include postoperative nausea/vomiting and small bowel obstruction; and surgical complications include accidental puncture or laceration and hemorrhage/bleeding. "Any" includes the complications shown, as well as mechanical wound (e.g., seroma, hematoma, persistent postoperative fistula), urinary (e.g., urinary tract infection), pulmonary (e.g., ventilator associated pneumonia and iatrogenic pneumothorax), cardiovascular (e.g., deep vein thrombosis, pulmonary embolism, stroke), and systemic (e.g., shock) complications. Points indicate the fold change (values > 1 indicate increase) and error bars are 95% confidence intervals.

4.3.1. Impact of leaks

4.3.1.1. Bariatric surgery

Leaks after bariatric surgery are relatively rare but remain a major concern for bariatric surgeons (see section 3.4.1). Different bariatric procedures carry different risks of developing a leak, due in part to different surgical mechanisms. Gastric bypass, for example, consists of the creation of two anastomoses and a gastric pouch, while sleeve gastrectomy requires no anastomosis but does have the creation of a long staple line along the curvature of the transected stomach. The etiology of leaks between these two procedures will therefore be different, as illustrated in a study comparing the impact of managing leaks after sleeve gastrectomy versus gastric bypass.¹⁰¹

A study of bariatric surgery complications from Israel focused on cases of leaks after gastric bypass (9 of 595 patients or 1.5%) and sleeve gastrectomy (16 of 2,132 patients or 0.75%, Figure 4-3).¹⁰¹ The results showed that the majority of patients in both groups required intervention to resolve the leaks, since spontaneous resolution with no intervention occurred in only 22% and 13% of gastric bypass and sleeve gastrectomy patients

LEAKS AFTER BARIATRIC SURGERY METHODS OF MANAGEMENT TO RESOLVE LEAKS

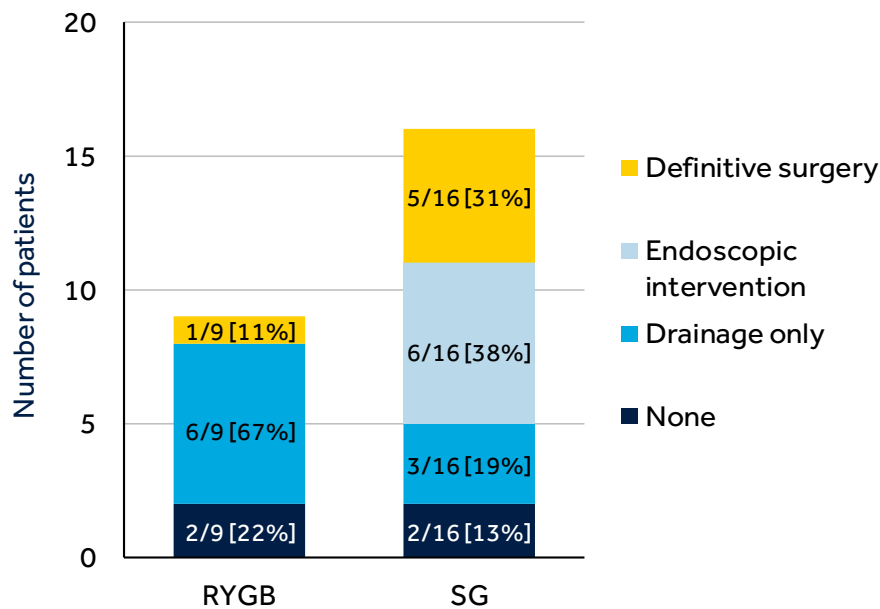

Interventions used in patients who were diagnosed with leaks after bariatric surgery were characterized in the study¹⁰¹ of Al Kurd et al., 2018. More patients in the RYGB group were managed with drainage only compared to SG and more patients could be managed with endoscopic interventions in the SG group compared to the RYGB patients. RYGB, Roux-en-Y gastric bypass; SG, sleeve gastrectomy.

Figure 4-4 Additional time burden due to leaks after bariatric surgery

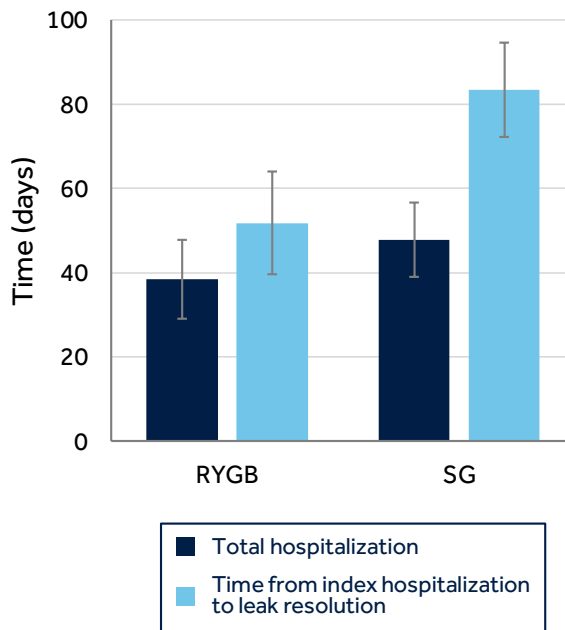

Data from the study of Al Kurd et al., 2018 are shown indicating the time from leak diagnosis until resolution and the time in that period spent in hospital.¹⁰¹ Bars indicate mean across number of patients with leaks in each group, and error bars are standard deviation.

Similar analyses of the additional burden of leaks with a focus on sleeve gastrectomy were performed in France³¹ and the Netherlands.⁷⁵ In the French study, a retrospective analysis of 2,012 sleeve gastrectomy patients whose operations were between 2005 and 2014, there were 20 cases of leaks (0.99% incidence), of whom 15 had complete data for analysis. Additional costs for the treatment of leaks were on average €34,398 of in-hospital costs (range €7,543 – €91,632) and €41,284 of outpatient costs (range €14,148 – €75,684) for a total management cost of €75,682.³¹ Authors noted that in their institution, more experience with performing sleeve gastrectomy in combination with the addition of staple-line reinforcement reduced their leak rates; considering the cost of reinforcement in relation to the high cost of leaks, in their series, a reduction of leak rate from 1.8% to 1.16% would compensate for the cost of using staple-line reinforcement in all sleeve gastrectomy patients.³¹

The Dutch study was also a retrospective analysis, in its case of 1,261 sleeve gastrectomy operations performed between 2006 and 2013, in which 32 leaks (2.5% incidence) were detected.⁷⁵ The definition of leak included the detection of any abscess adjacent to the staple line. Median costs per patient to treat these leaks were €9,284 (range €1,748 – €125,684).⁷⁵ These costs are considerably lower than those of the French study,³¹ but that difference may in part be due to differences in intervention algorithm and local institutional costs.

A study from the United Kingdom considered differences in management burden specifically after sleeve gastrectomy surgery.²⁹ The authors extended an earlier analysis of the public payer, national health service (NHS) cost of managing leaks to include costs incurred by self-paying patients in three scenarios of leak treatment (Figure 4-5). In their report (a conference abstract) only the additional costs of treatment were reported and not the base cost of the index sleeve gastrectomy operation. Additional costs ranged from £14,000 to £115,000. For comparison, costs for restrictive surgery for obesity in the UK for the year 2014-2015 were £4,771.^c

Figure 4-5 Costs associated with scenarios of leak management after sleeve gastrectomy

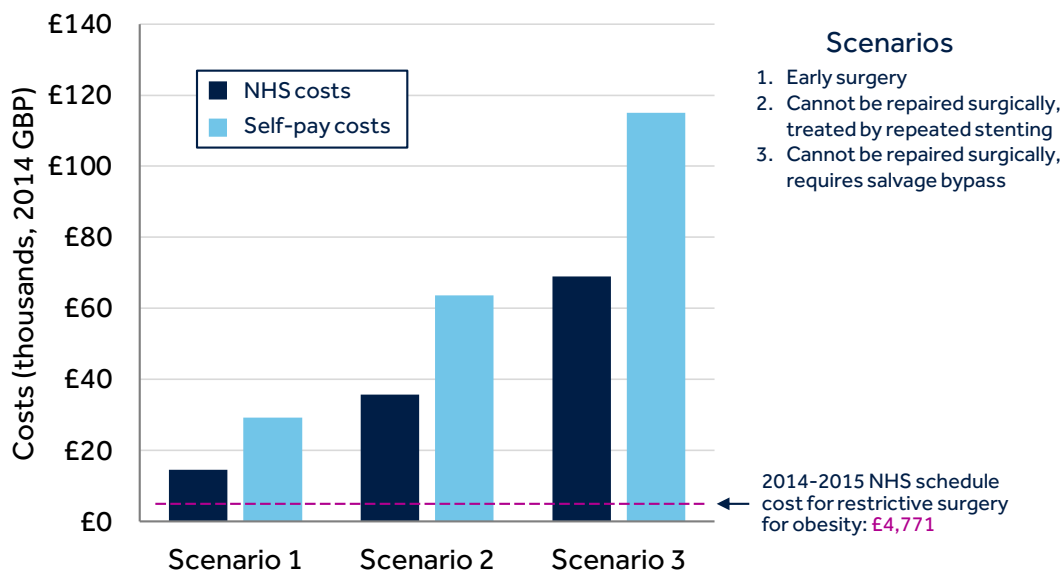

Data are taken from the conference presentation²⁹ of Ahmed et al., 2015. Scenarios are as shown, and uncertainties were not reported. GBP, Great Britain Pounds Sterling; NHS, National Health Service.

^c National schedule of reference costs, year 2014-2015. Healthcare resource group (HRG) code FZ85Z, restrictive surgery for obesity. URL: <https://www.gov.uk/government/publications/nhs-reference-costs-2014-to-2015>

4.3.1.2. Colorectal surgery

Colorectal resection requires the creation of anastomoses among different structures, depending on their location, and these become potential sites for a leak to occur. Additional costs attributable to management of leaks after colorectal surgery are considerable.⁹³ A retrospective study of hospital administration data in the United States for procedures performed between 2008 and 2010 identified 99,879 patients who underwent surgery on the colon or rectum that included creation of an anastomosis. Of these patients, 6,174 were identified as having had a leak (6.2% incidence). To reduce the effect of confounding variables, the authors performed propensity score matching among the patients who did not have leak to create a 1:1 set of matched patients. The average total hospitalization cost (index admission and readmission) for patients who experienced a leak was significantly higher than the matched control patients (\$73,000 ± \$95,000 versus \$44,000 ± \$52,000 respectively).⁹³

The results indicate a considerable increase in resource usage associated with the incidence of colorectal anastomotic leak, with a greater risk of postoperative infection and readmission to hospital within 30-days of discharge observed (Figure 4-6).⁹³ Accordingly, leak was also associated with longer hospital stays during the index admission, during any readmission (if one occurred), and overall (Figure 4-7). Similar patterns of significant increases were seen for costs during the different phases of treatment (Figure 4-7). These increases corresponded to a 57% to 65% greater burden (in hospital stay and costs) incurred for patients who experienced leaks after colorectal anastomosis compared to those who did not.

Figure 4-6 Incidence of infection and 30-day readmission after colorectal anastomotic leak

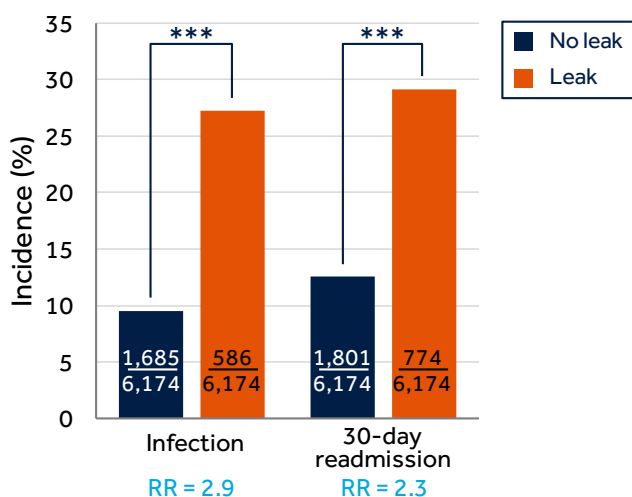

Data are shown from the hospital administrative database analysis⁹³ of Hammond et al., 2014. Bars indicate the incidence of the indicated outcome with patient counts superimposed. Values below axis labels indicate the relative risk of the outcome for patients who experienced leak compared to matched patients who did not. *** p < 0.001. RR, relative risk.

Figure 4-7 Hospital length of stay and costs associated with incidence of colorectal anastomotic leak

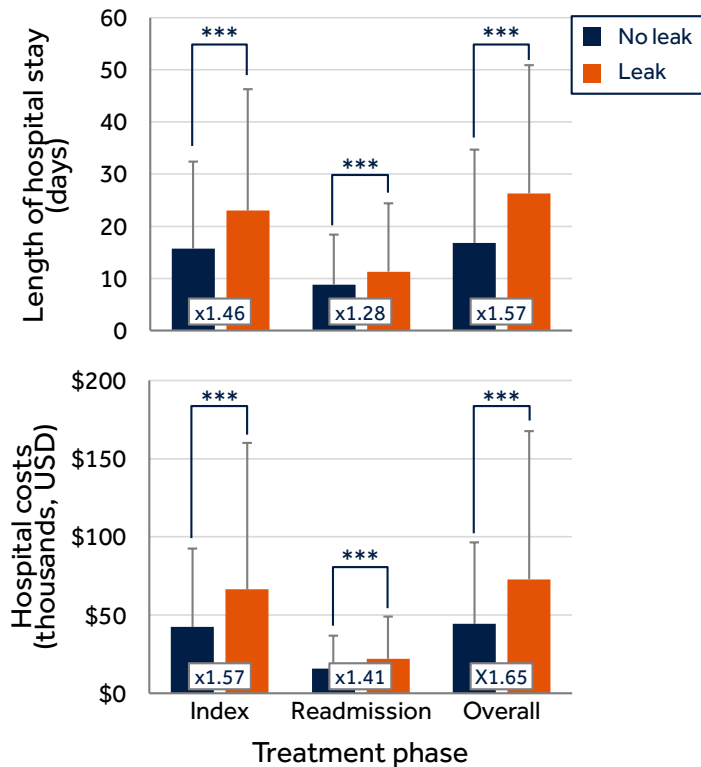

Data are shown from the hospital administrative database analysis⁹³ of Hammond et al., 2014. Bars indicate the mean (length of stay or cost), and error bars indicate standard deviations across three phases of treatment: the index hospitalization, during readmission (if one occurred) and overall. Values shown in boxes are the fold increase in the corresponding metric for patients with leak compared to the matched patients without leak. *** p < 0.001.

4.3.1.3. Pulmonary surgery

Operations on the lungs, whether involving parenchyma or bronchi, risk air leakage as a complication. As described earlier (section 3.4.1), most air leaks will spontaneously resolve within 5 days of the operation.⁹⁴ If the air leak persists, it is considered a prolonged air leak (PAL, often defined as a leak lasting longer than 5 or 7 days), and such leaks are associated with poor patient outcomes.^{77,95} The impact on cost of PAL (at the > 5 day threshold) was assessed, along with other pulmonary-related complications, in a retrospective analysis of hospital records of patients who underwent lobectomy for stage I non-small cell lung cancer (N=488) between 2008 and 2014 in the United States.²⁸ Of note, the authors considered costs in the 90-day period after discharge, unlike the often reported 30-day period. Authors examined PAL, pneumonia, and groupings of major (excluding PAL and pneumonia but counting tracheostomy, respiratory failure, and reintubation) and minor (atelectasis, pneumothorax, and other non-specified minor pulmonary events) pulmonary complications.²⁸ The impact on total direct costs was expressed as factor changes relative to the total direct costs for an uncomplicated lobectomy.

Significant increases in hospital costs were observed for all groupings of pulmonary complications relative to an uncomplicated lobectomy, ranging from 1.22 fold greater for PAL to 2.11 fold greater for major pulmonary complications (excluding PAL and pneumonia, Figure 4-8).²⁸ All increases were well above the upper boundary of non-complicated

procedures, which was approximately 1.03 fold above the mean cost of an uncomplicated lobectomy. The authors noted that the major pulmonary complications group, which had the greatest impact on costs (more than double compared to an uncomplicated procedure) was only experienced by a small proportion of patients (2.9%) highlighting the large impact on costs that can be caused by a small number of patients who experience a major complication.²⁸ What were classified as minor pulmonary complications (pneumothorax and continued need for ventilation) corresponded to a 1.31-fold increase in costs compared to uncomplicated procedures.²⁸

Figure 4-8 Cost increases for air leak and other pulmonary complications associated with lobectomy

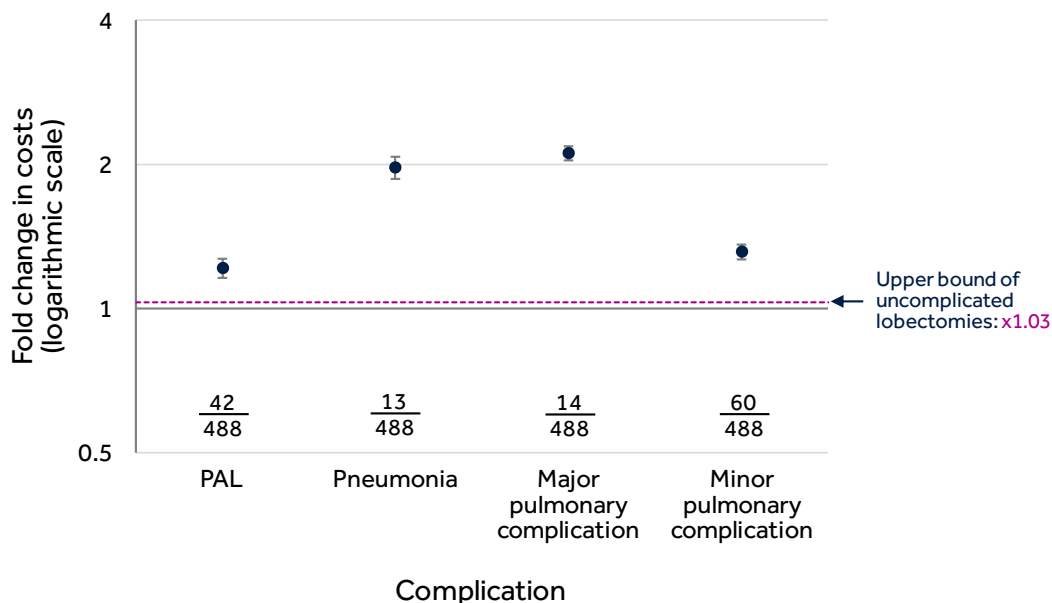

The study²⁸ of Geller et al., 2018 (N=488 patients) examined fold changes in costs for complications after lobectomy for non-small cell lung cancer relative to uncomplicated procedures (costs across 319 procedures that had no complications). Points indicate the fold change (increase) in costs, and error bars indicate 95% confidence intervals. Major pulmonary complications excluded PAL and pneumonia but included tracheostomy (4), respiratory failure (3), reintubation (3), complicated pleural effusion (2), acute respiratory distress syndrome (1), and pulmonary embolus (1). Minor complications included atelectasis (31), other unspecified minor pulmonary complications (20), pneumothorax (8), and continued need for ventilator (1). The dashed reference line indicates the upper bound of costs for uncomplicated procedures. PAL, prolonged air leak (leak lasting longer than 5 days).

4.3.2. Impact of bleeding

Bleeding as a complication can take multiple forms, but here is considered in relation to stapling. The staple line itself can exhibit bleeding intraoperatively, or bleeding can manifest as a major postoperative event that requires intervention.^{14,28,75,91}

4.3.2.1. Bariatric surgery

A Dutch retrospective study examined bleeding in 1,261 sleeve gastrectomies performed between 2006 and 2013.⁷⁵ Among these, 27 cases of bleeding were recorded (defined as bleeding requiring transfusion or relaparoscopy) for an incidence of 2.1%. The median cost to treat a bleed was €4,267 (range €1,524 – €40,022).⁷⁵ As the costs for an uncomplicated procedure were not reported, this increase cannot be expressed as a fold change. It is noted,

however, that the additional ward and intensive care unit stays were the major contributors to costs, accounting for 42% and 34.8% of additional costs respectively. Their reported usual length of stay was 2 days, in comparison to the median of 8 days in the general ward for patients with bleeding.⁷⁵

Studies of bleeding after bariatric surgery have also been performed in the United States using data from a nationwide metabolic and bariatric surgery quality improvement database of entries from the year 2015. In sleeve gastrectomy (N=98,142 patients)¹⁴ and gastric bypass (N=43,280 patients)¹⁰² postoperative bleeding cases were defined as those patients who required transfusions, or whose records indicated any additional intervention described as for the purposes of “bleeding” within 72 hours of the operation. The sleeve gastrectomy patients included those who received various forms of staple line reinforcement (including none) and demonstrated an overall bleeding incidence of 623 of 98,142 patients (0.63%).¹⁴ Of gastric bypass patients, 652 of 43,280 patients (1.5%) experienced a postoperative bleed.¹⁰²

The results suggest that patients who experienced postoperative bleeds used significantly more resources, regardless whether after sleeve gastrectomy or gastric bypass (Figure 4-9).^{14,102} Examples of the outcomes studied included the incidence of length of hospital stay of 3 days or longer and unplanned 30-day readmission, both of which were significantly higher for patients who had postoperative bleeds compared to those who did not.

Figure 4-9 Impact of postoperative bleeding after bariatric surgery on resource utilization

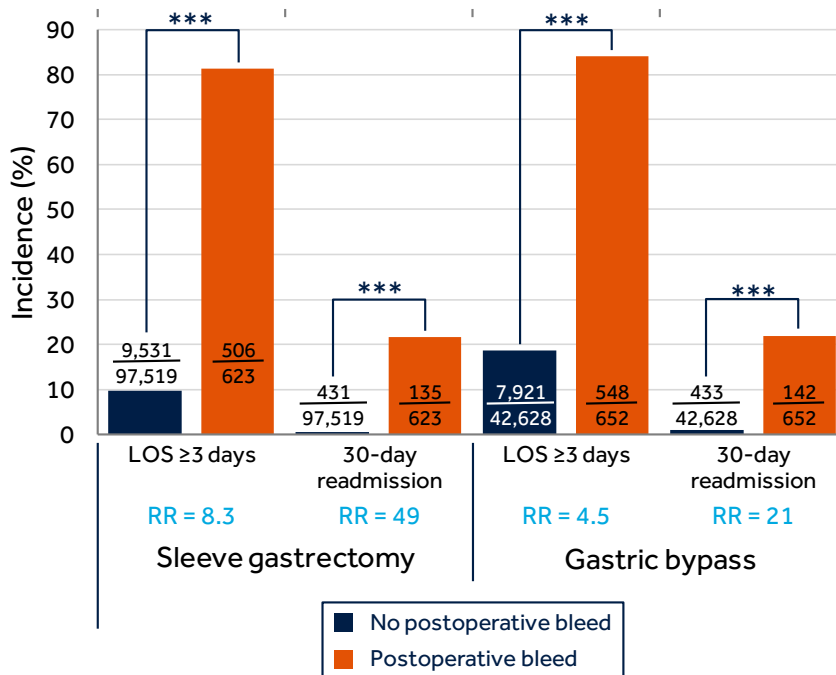

Data are shown from a nationwide database from the United States of sleeve gastrectomy¹⁴ and gastric bypass¹⁰² procedures comparing outcomes for patients who did and those who did not have postoperative bleeding. Bars indicate the incidence of the indicated outcome with patient counts superimposed. Values below axis labels indicate the relative risk of the outcome for patients who experienced bleeding compared to matched patients who did not. *** p < 0.001. LOS, length of stay; RR, relative risk.

4.3.2.2. Pulmonary surgery

The impact of major bleeding events has been assessed in the context of lung surgery. In addition to pulmonary-related complications, the United States analysis of patients who underwent lobectomy for stage I non-small cell lung cancer (N=488) between 2008 and 2014 included analysis of bleeding.²⁸ The outcome reported was of “major cardiac or bleeding” complications (identified in 33 of 488 patients for an incidence of 5.1%).²⁸ Most of these events, however, were for bleeding as patients who required transfusion (32 of the 33 cases). Patients who experienced these major cardiac or bleeding events saw costs significantly higher (1.22-fold) greater than those who had uncomplicated lobectomies.²⁸

A larger analysis in the United States examined hospital administration data of 21,429 patients who underwent primary pulmonary lobectomy or segmentectomy between 2009 and 2012.²⁵ Bleeding events were categorized into “significant” (requiring at least 3 units of blood products), “non-significant” (requiring less than 3 units), and “none” groups, and the incidence, length of hospital stay, and costs were compared.

Bleeding events of either kind (significant or non-significant) were associated with significantly greater burden compared to patients without bleeding.²⁵ The incidence of “non-significant” bleeding was 13% (2,780 of 21,429 patients) and of “significant” bleeding 0.99% (213 of 21,429 patients). In terms of both hospital length of stay and average costs per patient, both types of bleeding events led to significant increases compared to those with no bleeding, even after accounting for age and disease severity (Figure 4-10).²⁵

Figure 4-10 Impact of level of bleeding on hospital resources after pulmonary surgery

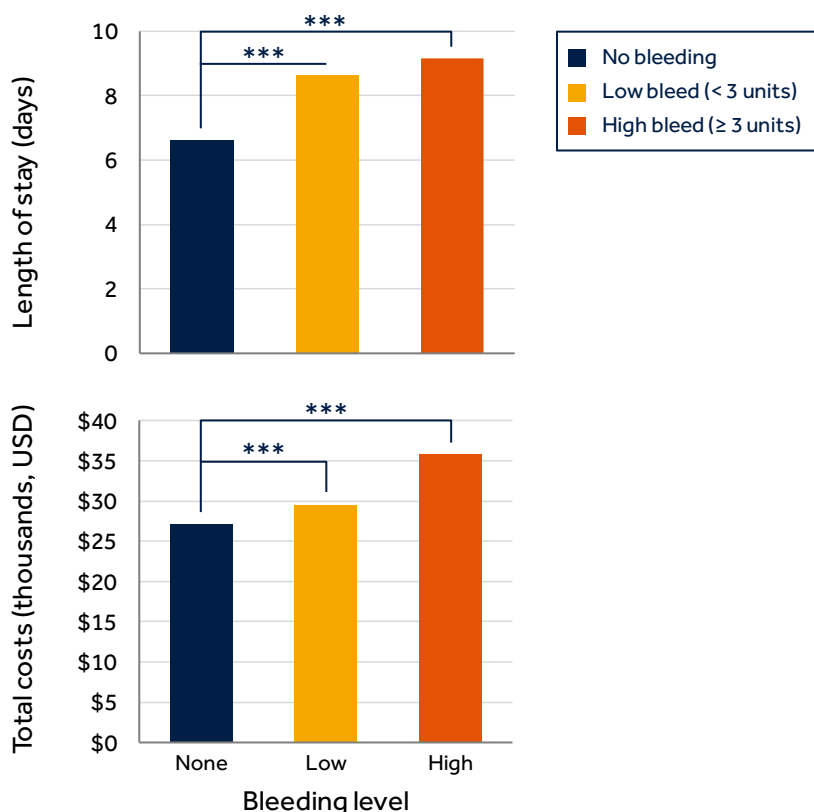

Data are shown from the retrospective study of Ghosh et al., 2016 of a hospital administration database consisting of 21,429 patients who underwent lobectomy or segmentectomy.²⁵ Bars indicate reported means for patients classified as having a high bleeding event, low bleeding event or no bleeding. All differences for bleeding versus non-bleeding were reported as significant, but no uncertainties or ranges for the means were provided. *** $p < 0.001$.

4.3.3. Impact of other complications

4.3.3.1. Postoperative nausea and vomiting

In comparison to the more serious potential staple line complications of leak and bleeding, either of which could contribute to mortality, postoperative nausea and vomiting (PONV) may seem a minor complication. Its occurrence can, however, still have an impact on economic outcomes after surgery.¹⁰⁰ Prospectively collected data from a quality improvement database were retrospectively analyzed for patients who underwent bariatric surgery at a single institution between 2014 and 2017.¹⁰⁰ The overall incidence of PONV was 36% (160 of 449 patients) with a higher rate among sleeve gastrectomy patients (107 of 252 patients, 43%) compared to gastric bypass patients (53 of 197 patients, 27%). The costs associated with PONV in the two groups were not reported, however, the incidence of events including reoperation, 30-day emergency room visits, and 30-day readmission were reported (Figure 4-11) as well as the length of the index hospital stay (Figure 4-12).¹⁰⁰ For both surgery types, there was a significant increase in the length of hospital stay (79% longer in sleeve gastrectomy, 2 times longer in gastric bypass) for patients with PONV versus those who did not have the complication.¹⁰⁰ Among other resource usage indicators, the one showing the greatest effect was the incidence of visit to an emergency department within 30 days of discharge. PONV was associated with a relative risk of 1.72 (non-significant) after sleeve gastrectomy and 3.1 (significant) after gastric bypass.¹⁰⁰

Figure 4-11 Resource usage after bariatric surgery without and with PONV

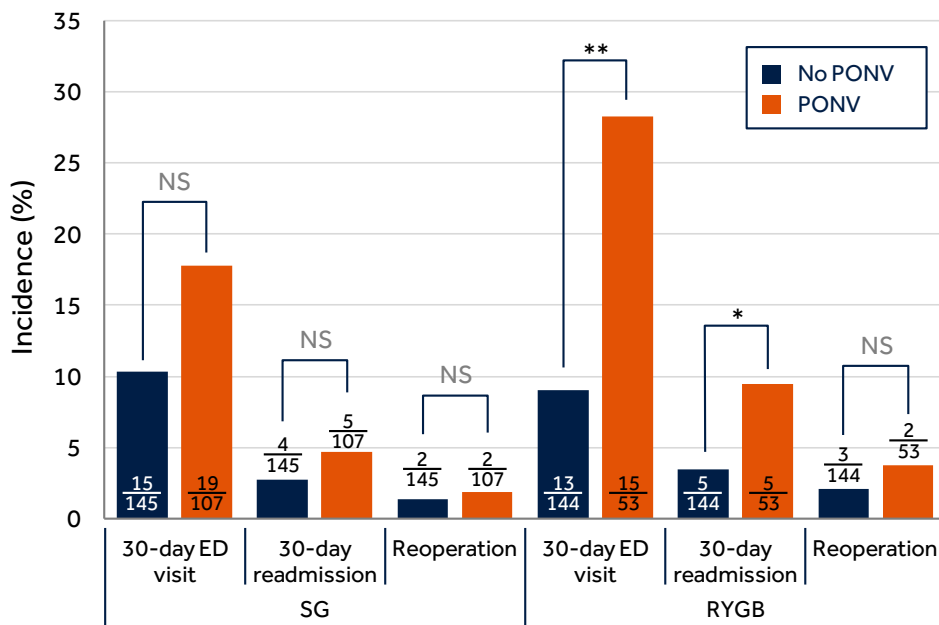

Data from Suh et al., 2019 are shown for select resource usage outcomes for patients after bariatric surgeries with and without PONV.¹⁰⁰ Bar heights correspond to the incidence of the indicated event as a percentage, and superimposed values indicate the numbers of patients with the complication over the total in that group. NS, non-significant; ** p < 0.01; ED, emergency department; PONV, postoperative nausea and vomiting; RYGB, Roux-en-Y gastric bypass; SG, sleeve gastrectomy.

Figure 4-12 Length of index hospital stay after bariatric surgery without and with PONV

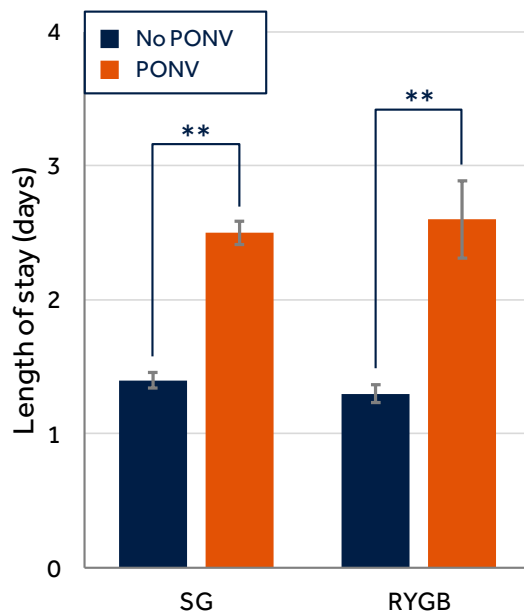

Data¹⁰⁰ from Suh et al., 2019 are shown for length of index hospital stay associated with bariatric surgeries with and without PONV. Bars correspond to the mean, and the error bars are standard deviations. * $p < 0.05$; RYGB, Roux-en-Y gastric bypass; SG, sleeve gastrectomy.

4.3.3.2. Postoperative pancreatic fistula

Stapling has been used in surgeries involving resections of the pancreas, such as pancreatectomy and pancreaticoduodenectomy (see Table 3-5). While not specifically the result of staple line closure, postoperative pancreatic fistula (POPF) is a complication that can occur after such surgeries. According to an internationally-recognized classification system established in 2005, not all occurrences of POPF are clinically relevant.¹⁰³ Of the three categories (A, B and C) only the latter two, B and C, have a considerable impact and are considered clinically-relevant POPF (CR-POPF).

The burden of CR-POPF according to this classification system has been assessed in a retrospective study from Sweden that compared outcomes between patients who underwent pancreaticoduodenectomy and had no or asymptomatic (grade A) fistula and those with CR-POPF (grade B/C).¹⁰⁴ Of the 322 patients with complete data whose operations occurred between 2005 and 2015, 39 (12%) experienced CR-POPF. Significantly more of these patients required a stay in the intensive care unit (36% versus 7.4%, $p < 0.001$), and significantly more required reoperations (10% versus 1.4%, $p < 0.01$, Figure 4-13). Significant increase in burden for patients with CR-POPF is also seen in the increased length of stay (2.3-fold greater, Figure 4-14) and increased in-hospital costs (1.5-fold greater, Figure 4-15) compared to those without the complication.

Figure 4-13 Impact of postoperative pancreatic fistula on hospital events

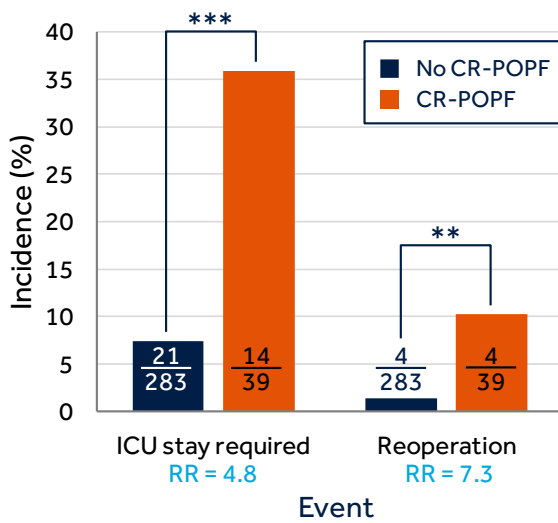

Shown are data¹⁰⁴ from Williamsson et al., 2017 showing differences in requirement of intensive care unit stay (ICU) and reoperation for patients without and with CR-POPF who underwent pancreaticoduodenectomy at an institution in Sweden between 2005 and 2015. Bar heights indicate the incidence as a percentage, and superimposed values indicate the numbers of patients with the event over the total number of patients in that group. Below the axis labels are shown the relative risk calculated for each outcome for those with CR-POPF versus those who did not have CR-POPF. ** p < 0.01; *** p < 0.001. CR-POPF, clinically-relevant postoperative pancreatic fistula; None/A, no CR-POPF or grade A POPF; RR, relative risk.

Figure 4-14 Difference in length of hospital stay for patients without and with postoperative pancreatic fistula

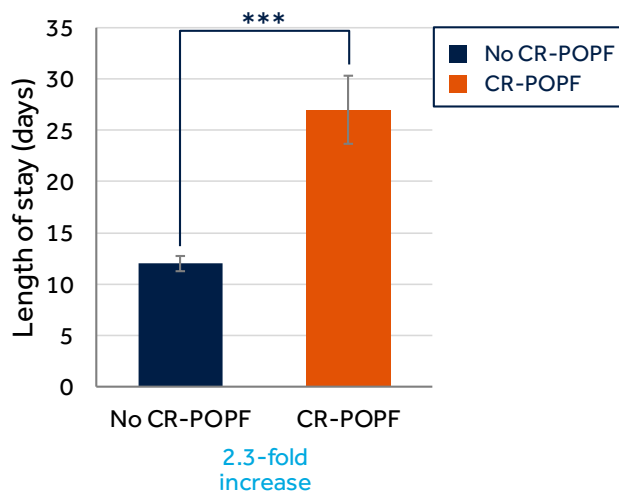

Data are shown from the study¹⁰⁴ of Williamsson et al., 2017 of differences in length of hospital stay. Bars indicate the median length of stay as reported, and error bars are the standard error of the mean, estimated using the method¹⁰⁵ of Wan et al., 2014 from the reported ranges. The value shown below the axis labels indicates the factor increase in length of stay for patients with CR-POPF versus those without. *** p < 0.001. CR-POPF, clinically-relevant postoperative pancreatic fistula.

Figure 4-15 Difference in costs for patients without and with postoperative pancreatic fistula

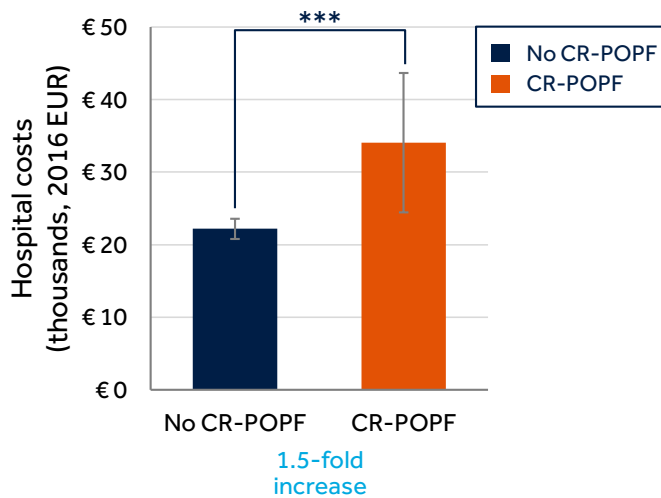

Data are shown from the study¹⁰⁴ of Williamson et al., 2017 of reported costs (in thousands of 2016 EUR) for patients who experienced CR-POPF after pancreaticoduodenectomy. Bars indicate the median cost, and error bars are the standard error of the mean as estimated using the method¹⁰⁵ of Wan et al., 2014 from the reported ranges. The value shown below the axis label indicates the fold increase in length of stay for patients with CR-POPF versus those without. *** $p < 0.001$. CR-POPF, clinically-relevant postoperative pancreatic fistula.

4.4. Role of technology in reducing complications

As evidenced by the studies outlined earlier in this chapter, the occurrence of complications increases the burden on healthcare systems. This observation is true in terms of increased resource utilization in the need for additional interventions,^{14,29,104} increased hospital length of stay,^{14,27,75,100,101,104} and higher costs of care, including more hospital and outpatient visits.^{28,31,75,93} Efforts to reduce the incidence of complications may therefore not only improve patient care but also lead to improved performance of the healthcare system.

In addition to official guidelines, the body of medical literature is replete with suggestions and recommendations for reduction of complications.^{6,28,32,54,95,106} These can include adjustments to the surgical technique, or recommendations for technologies that, when used appropriately, may aid in reduction of complications.

An example is staple-line buttressing in bariatric surgery, which has been evaluated for its impact on complications and resource utilization.³⁰ In a retrospective study of sleeve gastrectomy in a French hospital between 2013 and 2014, patients whose staple lines were not reinforced (N=116, first half of study period) were compared to patients with exogenously added absorbable mesh reinforcement placed on the staple cartridge (N=86, latter period). The study focused on patients at high risk of leak or bleeding: those with age > 60 years, with hypertension or diabetes at baseline, body mass index > 50 kg/m², and those on anticoagulant therapy. Significantly lower rates of bleeding were observed with buttress (relative risk 0.06, corresponding to a 16-fold lower risk of bleeding with buttress versus no buttress, $p < 0.01$), while non-significantly lower rates of leak and reoperation were also observed (Figure 4-16). These results provide further evidence in support of an earlier international sleeve gastrectomy panel consensus statement, whose panel comprised 24 centers from 11 countries with total experience of over 12,000 surgeries.³⁷ Among the surveyed participants, 100% believed reinforcement of the staple line would reduce

incidence of staple line bleeding; 95% and 77% considered oversewing and buttressing of the staple line acceptable, respectively.³⁷

In terms of hospital resource utilization, the patients in the buttressing group compared to the no-buttressing group had a significantly shorter length of stay (4.2 ± 0.9 days versus 5.2 ± 3.8 days, $p = 0.005$) but also a significantly longer operating time (155 ± 29 mins versus 142 ± 29 mins, $p = 0.002$).³⁰ The additional operative time was attributed to the time required to position the absorbable mesh over the stapler cartridge in the buttressing group. Calculated as costs, most of the cost categories associated with the surgery were significantly different between the two groups; aside from buttressing and intraoperative, the totals for extraoperative and the overall costs were lower for the buttressing versus the non-buttressing group (Figure 4-17).³⁰

Figure 4-16 Evaluation of staple-line buttressing impact on sleeve gastrectomy complications in high-risk patients

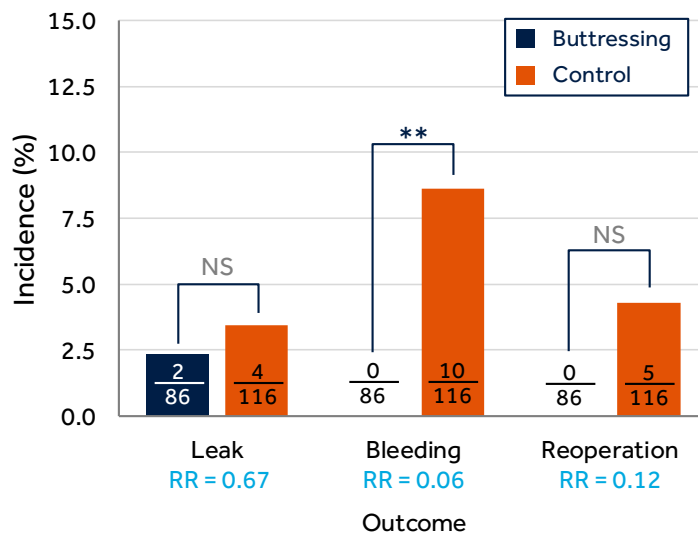

Data are shown for patients with and without absorbable mesh buttressing of the staple line during sleeve gastrectomy in high-risk patients from the study³⁰ of Gayrel et al., 2016. Bar heights indicate the incidence as a percentage, and superimposed values indicate the numbers of patients with the complication or event over the total number of patients in that group. Below the axis labels are shown the relative risks calculated for each outcome. Note that for the relative risk calculation for those outcomes with zero counts (bleeding and reoperation), a corrective value of 0.5 is added to each group. ** $p < 0.01$; NS, non-significant. RR, relative risk.

Figure 4-17 Evaluation of staple-line buttressing on sleeve gastrectomy costs in high-risk patients

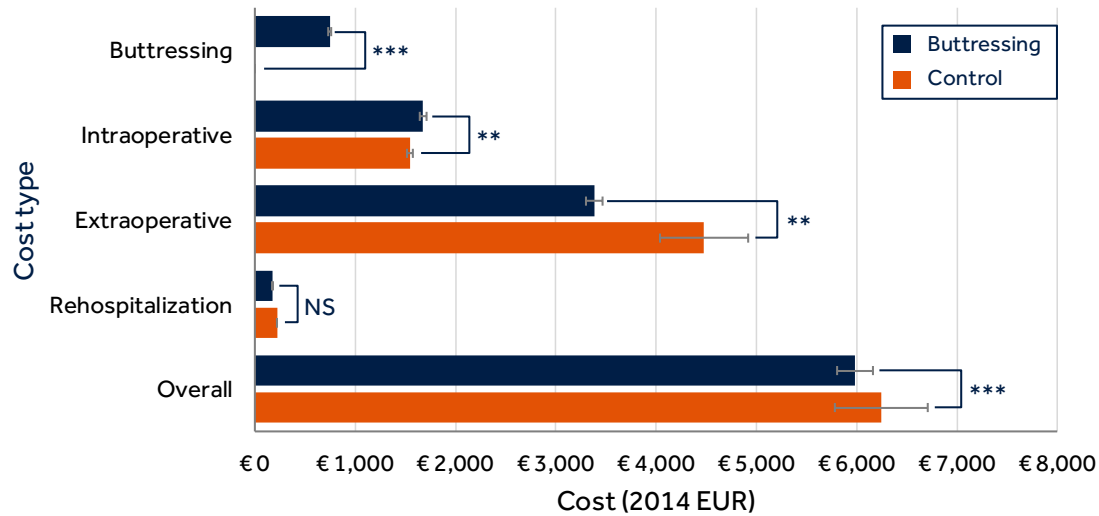

Data are shown for patients with and without absorbable mesh buttressing of the staple line during sleeve gastrectomy in high-risk patients from the study³⁰ of Gayrel et al., 2016. Bar lengths indicate the mean cost of the indicated item, and error bars show the standard error of the mean. Rehospitalization costs and uncertainties were only reported for the patients who returned to hospital, not the entire cohort, therefore inferential statistical testing between the buttress and no-buttress group was not reported. ** p < 0.01; *** p < 0.001; NR, not reported; RR, relative risk

4.5. Stapling and reducing complications

With an aim to improving patient safety, authors have proposed ideas and design concepts that may contribute to reducing the incidence and burden of surgical complications that have been associated with stapling. A sampling of recommendations is listed in (Table 4-1).

Table 4-1 Suggestions for improving surgical performance of stapling

Surgical area	Concept	Suggestion
Bariatric	Staple height	"Because of the range of gastric thicknesses, a single staple height cannot be used to appose the full range of gastric wall thicknesses without potentially causing necrosis or poor apposition." ³³
		Appropriate cartridge selection from antrum to fundus ¹⁵
	Staple height + technique	Matching of staple height to tissue thickness and longer compression time ^{24,32}
	Staple line properties	Too much clamping or clipping at wound edges has adverse effects on healing. ⁷⁸
		Inadequate tissue healing allows for anastomotic or staple line leaks. ²⁴
	Reinforcement	Reduction in leak rate in institutional experience of reinforcement would more than compensate additional cost of buttressing. ³¹
Bleeding complications, length of stay, and total costs were reduced in patients with buttressing. ³⁰		
		Reinforcement has reduced risk of leak (SG) and bleeding (RYGB, SG). ¹⁵

Surgical area	Concept	Suggestion
Thoracic	Staple height	Use of staple cartridges with longer leg length to address possible tissue thickness mismatch ⁶ Shorter leg staples to decrease oozing ³⁴
	Staple height + technique	Taller staple height and longer compression in peripheral lung tissue ³⁴
	Stapler design	Avoiding stress from twisting/lifting when stapling vessels ¹⁰⁶ Complications in vascular stapling during pulmonary surgery may be reduced by improving visibility and stability during firing. ²⁵
	Technique	For central lung tissue use less force and shorter compression time ³⁴
	Reinforcement	Staple line reinforcement may reduce pulmonary surgery complications including air leaks ⁶ and recurrent pneumothorax. ¹²
Colorectal	Stapler design	Narrow workspace in low anterior region may result in more stapler firings to create an anastomosis, ³⁵ which has been associated with risk of leak. ¹⁰⁷
	Reinforcement	"Staple line reinforcement [...] reduce[s] the drawbacks of staplers used in colorectal practice, i.e.[,] leakage, bleeding, misfiring[,] and inadequate tissue approximation." ¹³

RYGB, Roux-en-Y gastric bypass; SG, sleeve gastrectomy.

Stapler manufacturers may consider the above-mentioned suggestions in refining stapler technology. In the case of Medtronic plc, offerings in staple (Tri-Staple™ technology) and stapler (the Signia™ stapling system) technology have been designed to address many of the above issues, among others. The remainder of this dossier is dedicated to detailing features, preclinical testing, and clinical outcomes of Tri-Staple™ technology and Medtronic plc powered stapler technologies (iDrive™ and the Signia™ stapling systems). Subsequent chapters explore features of Tri-Staple™ technology and specialty reloads designed to address issues that have been raised to improve stapler performance (Table 4-1) including:

- [Appropriate cartridge selection \(cartridges, section 5.2 and range described previously in section 3.4.4\)](#)
- [Taller staples \(black reloads, section 5.3.1\), reduction of stress on vessels while firing \(fixed anvil design, section 5.3.2\)](#)
- [A cartridge to improve low pelvis access in colorectal resections \(radial reload, section 5.3.3\)](#)
- [Cartridges with preloaded reinforcement material \(section 5.3.4\)](#)

The final section examines powered stapling and the Signia™ stapling system with its Adaptive Firing™ technology and force sensing technology (chapter 8) that help regulate the staple firing process (to a degree as desired by the surgeon) to aid in management of tissue compression, rate of firing, and the stability of the cartridge tip during firing.

CHAPTER 5

TRI-STAPLE™ TECHNOLOGY

- Recent evolution in Medtronic stapling technology
- Tri-Staple™ technology overview
- Specialty reloads



2010
Introduction of
Tri-Staple™
technology



2012
iDrive™
powered
stapler



2014
Tri-Staple™
technology
reinforced
reload

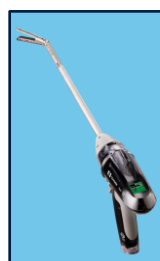

2016
Signia™ smart
stapling
technology

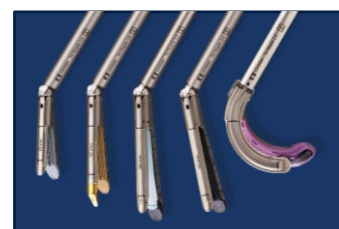

2016
Tri-Staple™ 2.0
reloads

5. Tri-Staple™ technology

5.1. Recent evolution in Medtronic stapling technology

Stapling technology has borne witness to numerous improvements and upgrades over the decades since its first introduction (Figure 3-2). Some features have persisted, as they already demonstrated desired design features: the ultimate “B” shape of the staple, staggered rows of staples, and modular design, enabling exchanging of cartridges for versatility during surgery. Other features have been improved, building on the earlier designs. A select representation of the evolution of stapler and supporting technologies across Medtronic products is illustrated in Figure 5-1. Innovations include the advent of an endoscopic version of the stapler to move beyond open surgeries and increased maneuverability with the introduction of articulating arms. The staples and cartridges themselves have also seen modification in the introduction of Tri-Staple™ technology (see section 5.2).

Figure 5-1 A recent history of Medtronic plc stapling technology innovation

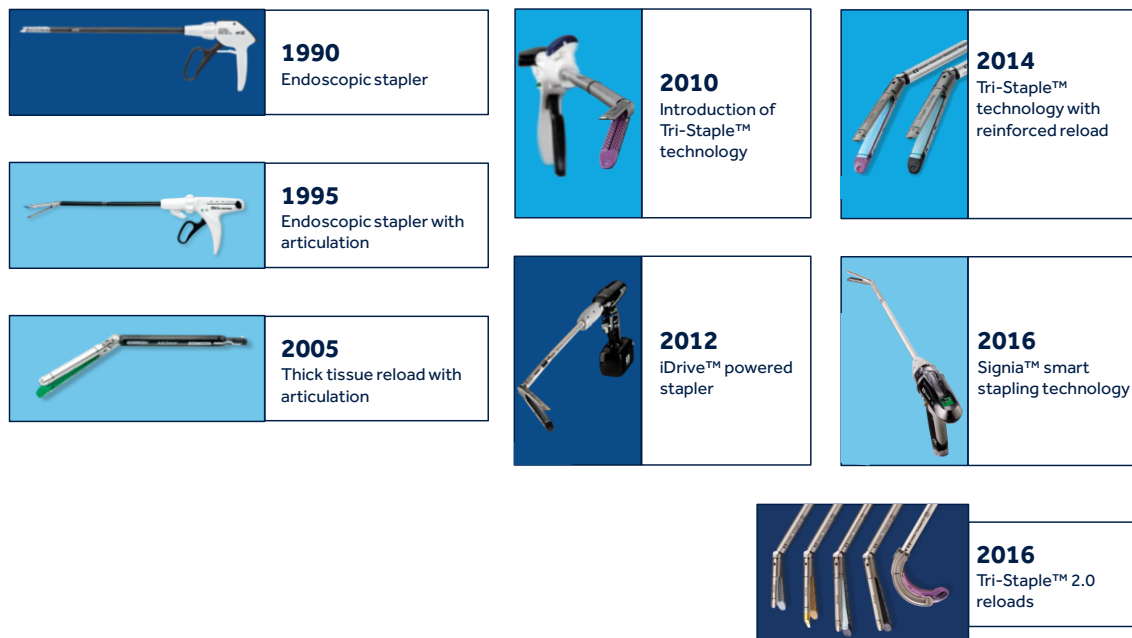

Innovations to stapling technology introduced via Medtronic products over the past 30 years.

5.2. Tri-Staple™ technology

Tri-Staple™ technology incorporates staple and stapler design features that have been long-established as beneficial to surgical stapling performance. The “B” staple shape that has been a feature of stapling since the earliest designs is to allow blood flow through the openings.² Additional early developments included the discovery that clamping of the tissue prior to firing of staplers is also beneficial and that staggered rows of staples aid in apposition security.² Both design factors have been maintained in modern manufacturing across major manufacturers.

Tri-Staple™ technology builds on these well-established design features. The design of the cartridge has been modified to reduce stress on tissues during the requisite tissue compression stage,^d and the concept of maintenance of blood supply is addressed by gradually increasing staple heights from the central cut line laterally to the sectioned tissue (Figure 5-2).¹⁰⁸

Figure 5-2 Tri-Staple™ technology overview

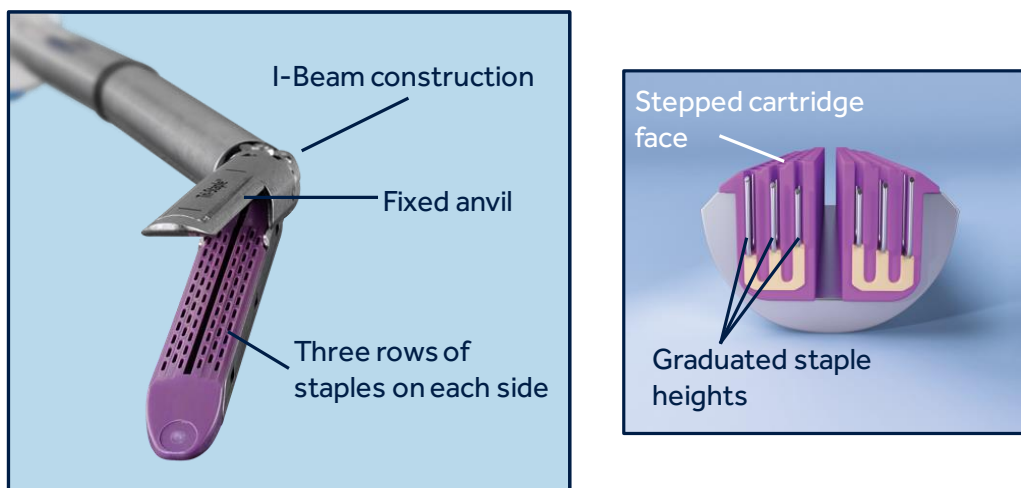

Features incorporated in Tri-Staple™ technology.

^{d†} Internal testing report PCG-026-Rev1, Feb. 2016. Sample sizes determined ad hoc for internal analysis; no independent reference testing standard has been established. Sample measurements were GST n=12, Endopath n=6, Tri-Staple n=4. Statistical significance defined a priori as p-value < 0.05. Test items were Ethicon Endopath Echelon™* green 60 mm GST reload (GST60G) and Ethicon Echelon Reload (ECR60G) fired with Ethicon Echelon Flex™* Powered Plus Stapler (PSEE60A); Medtronic Tri-Staple™ Purple 60 mm Endo GIA™ reload (EGIA60AMT) fired with Medtronic iDrive™ Ultra Powered Handle with linear adapter. Note that bench test results may not be indicative of clinical performance.

5.3. Specialty reloads

In addition to the features built into Tri-Staple™ technology aimed at improving stapling performance across a broad range of surgical applications, specialty reloads have also been designed to address specific needs. A selection of these specialty Tri-Staple™ technology reloads is shown in Figure 5-3.

Figure 5-3 Tri-Staple™ technology specialty reloads

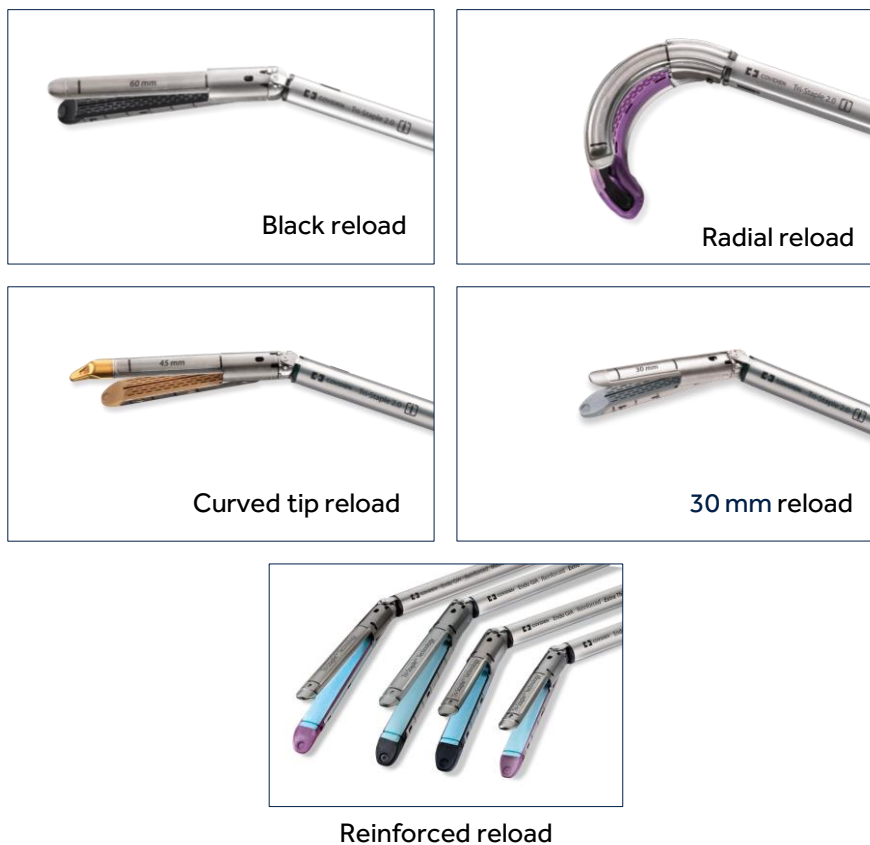

5.3.1. Tri-Staple™ technology black reloads

The Tri-Staple™ technology black reload contains the largest staple sizes available in the Tri-Staple™ technology line and currently on the market (among Medtronic plc products). The open staple heights are 4.0 mm, 4.5 mm, and 5.0 mm, which reduce to 2.25 mm to 3.0 mm after compression. These reloads are the most suitable for thick tissue and have therefore commonly found application in bariatric surgery (sleeve gastrectomy) where thick tissues of 2–3 mm in the fundus and corpus of the stomach can be found (see Table 3-3).⁵³⁻⁵⁶ Black reloads have also been used in the thick tissue of the pancreatic stump during distal pancreatectomy^{46,49} As noted previously (section 3.4.4), estimation of tissue thickness intraoperatively can be challenging; one group prospectively investigating the use of Tri-Staple™ technology in lung surgery concluded that using the larger-staple black reload in cases of uncertainty of tissue thickness was potentially beneficial for reducing the risk of postoperative air leaks.¹⁶

5.3.2. Tri-Staple™ technology curved tip reloads

Laparoscopic linear staplers have a broadly similar rectangular profile. This shape may not be ideal for accessing narrow areas where other structures such as bone may interfere or there may be a risk of damage to adjacent vasculature. The curved tip reload with Tri-Staple™ technology has a redesigned shape with dull side edges to help prevent laceration of the adjacent vasculature during pulmonary resections, and with its flexible introducer attachment, has been described as “making insertion into hilar structures much easier.”⁶ The availability of this specialty reload has also been described as a “critical” addition to the surgeon’s armamentarium for division of pulmonary vessels or the bronchus.⁵⁸

Some aspects of the precise impact of Tri-Staple™ technology with curved tip reload on operative technique were revealed in a retrospective review of 798 firings of curved tip reloads in thoracoscopic lung resections.⁵⁷ In the video records reviewed (45 complex cases), the authors noted significant reductions in the proportions of prolonged passage times (time taken to pass the stapling tip around the target tissues) of 33 (p = 0.001) and 14 (p = 0.02) percentage points.⁵⁷ Although the period of time that the operations were performed spanned a number of years (2004–2011), the authors further noted that the reduction in maneuver time was independent of learning curve, since time reductions were still observed even early in the study period.⁵⁷

5.3.3. Tri-Staple™ technology radial reloads

The rectangular shape of laparoscopic linear staplers can also prove restrictive in the case of colorectal surgery, where the pelvis may interfere with access to the low anterior segment of the bowel.¹⁰⁹ Additionally, limited angulation of available staplers may impede creation of optimal traction and counter-traction to complete total resection.¹⁰⁹

To address this technical issue, Tri-Staple™ technology with radial reload may facilitate the required access with its arced, rather than linear cartridge shape. Preclinical investigations on human cadavers have suggested improved access to the low pelvic region to facilitate targeting of the bowel.⁵ Examples of clinical use of Tri-Staple™ technology with radial reload for colorectal surgery include studies of single incision laparoscopic surgery using umbilical access for rectal transection¹¹⁰ and anterior resection.⁴⁵ An international survey of colorectal surgeons evaluating the technology found that in 93% of procedures (79 of 85) assessed by 31 surgeons the Tri-Staple™ technology with radial reload was considered clinically appropriate and in 96% of them, the device facilitated access in the low pelvis.³⁵

The redesigned profile of the radial reload has not only found application in colorectal surgery. A study investigating different stapling patterns to generate the gastric tube after esophagectomy found that a method using the radial reload for the first stapling at the antrum was associated with the need for fewer cartridges compared to methods using linear staplers.¹¹¹ The Tri-Staple™ technology with radial reload group also had a lower leak rate (0 of 18 patients) compared to the linear stapled group (4 of 25 and 3 of 19).¹¹¹

The curved cartridge of the Tri-Staple™ technology radial reload has additionally been used in lung surgery. Surgeons performing single-port thoracoscopic wedge resection noted the challenge presented by placement of the port in proximity to the lesion to allow palpitation.⁶² Such placement, however, makes sectioning of lung tissue difficult using linear articulating staplers. In the authors’ case series, the Tri-Staple™ technology with radial reload was found to be useful in overcoming the restriction of single-port surgery.⁶² Other authors have also noted the challenge presented by port access and staple firing.⁶³ When using a device to first mobilize tumor tissue to be resected, the authors initially created a separate port to allow access for the linear stapler to create a suitable margin around the encapsulated

tissue.⁶³ With the advent of the radial reload, however, the stapler could be inserted through the same port as the capture device to resect the tissue and provide sufficient mobilization such that subsequent sections could be performed with a linear stapler.⁶³ The method has been applied successfully over 56 firings for wedge resection and division of the bronchus in lobectomy.⁶³

5.3.4. Tri-Staple™ technology reinforced reload

Complications such as leakage and bleeding related to the creation of the staple line remain a concern for surgeons (section 3.4.1). Reinforcement of the staple line using different methods has been investigated as a method of reducing these complications^{11,13,14} and among them is the incorporation of buttressing material into the staple line as it is created.

Tri-Staple™ technology with reinforced reload is an example of reinforcement within the staple line. To facilitate application in the operative setting, the absorbable polyglycolic acid sheet is preloaded into the cartridge; other forms of buttressing materials are available as sleeves that are added to the stapling cartridge and the anvil of the stapler intraoperatively before initiating the staple firing sequence.²⁴ Tri-Staple™ technology with reinforced reload has been applied in surgeries on the stomach,^{40,44} lungs,^{41,42} pancreas,^{46,48,50,52} and rectum.¹⁸ Further details of clinical outcomes related to Tri-Staple™ technology with and without reinforcement are detailed in Chapter 7.

5.3.5. Tri-Staple™ technology 30 mm reloads

Linear stapler cartridges typically come in lengths of 45 mm and 60 mm. In some surgical applications, however, deployment of these cartridge lengths may be impractical if the operating field is anatomically-restricted or when the required suture line is very short.¹¹² In such cases, the 30 mm Reload with Tri-Staple™ technology may instead be suitable to provide stapling in tight spaces. Clinical applications have been reported in liver resection (30 mm Tri-Staple™ technology with curved tip reload),⁵⁹ appendectomy,⁶⁰ and gastrojejunal anastomosis during gastric bypass.⁶¹

5.4. Real-world clinical use of Tri-Staple™ technology

Tri-Staple™ technology, an innovation in stapling technology from Medtronic plc, encompasses design features, product development, and adjunct technologies described in the preceding sections. The technology has found wide use across the world, including reports originating from 25 countries: Australia, Austria, Belgium, Brazil, Canada, China, France, Germany, India, Israel, Italy, Japan, Macedonia, Mexico, Netherlands, Poland, the Russian Federation, Saudi Arabia, South Korea, Spain, Sweden, Switzerland, Turkey, United Kingdom, and the United States (Figure 5-4). Among these reports, a variety of surgical applications are represented involving general, gastrointestinal, and thoracic procedures (Table 5-1).

Figure 5-4 Global reports of Tri-Staple™ technology clinical use

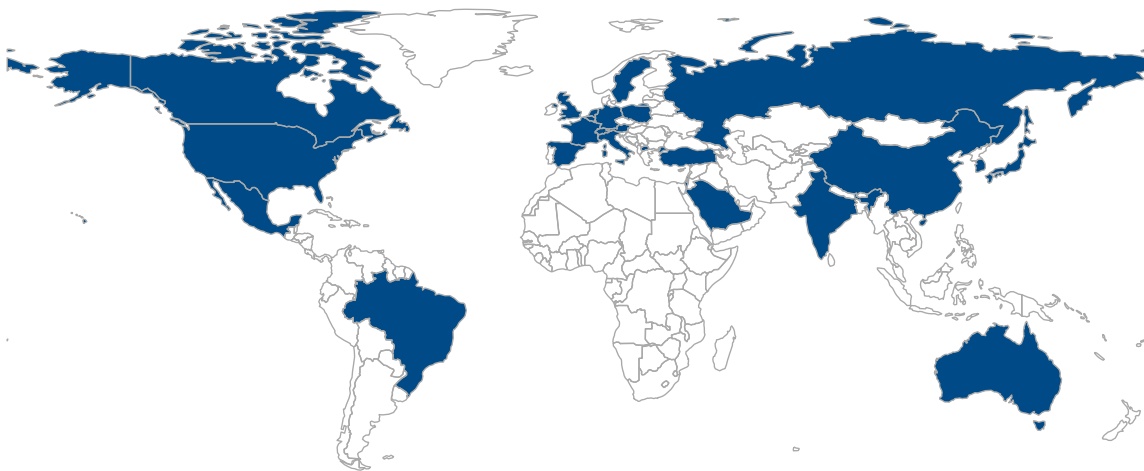

Highlighted countries indicate those where published reports of Tri-Staple™ technology use in a clinical setting with human patients were uncovered by literature searches for the present dossier. The collected references represent 117 studies from 25 countries. Refer to supplementary file “Tri-Staple clinical and geographical citation data.xlsx” for citation details.

Table 5-1 **Reported clinical applications of Tri-Staple™ technology**

Group	Organ	Procedure
General (30)	Pancreas (15)	Distal pancreatectomy (14)
		Pancreaticoduodenectomy (1)
	Liver (9)	Hepatic resection (9)
	Spleen (5)	Splenectomy (5)
	Gallbladder (1)	Cholecystectomy (1)
	Appendix (1)	Appendectomy (1)
	Prostate (1)	Prostatectomy (1)
	Other (1)	Aneurysmectomy (1)
Gastrointestinal (74)	Upper GI (7)	Esophagectomy (7)
		Gastrotomy (bezoar) (2)
		Gastrectomy (7)
	Stomach (48)	RYGB (7)
		Bariatric (39)
		SG (31)
		OAGB (2)
	Lower GI (19)	SADI (1)
		Polypectomy (colon) (1)
		Gastro-colic fistulectomy (1)
		Colon resection (8)
Rectal resection (4)		
	Anterior resection (5)	
Thoracic (13)	Lung (12)	Pulmonary resection (12)
	Other(1)	Diverticulectomy (1)

A breakdown of categories, organ systems, and procedures where clinical application of Tri-Staple™ technology in human patients have been reported. Reports include peer-reviewed and conference presentations. Numbers in parentheses indicate the number of reports under each heading; note, however, that some studies report data for multiple procedures and these will therefore be counted more than once under the organ and procedure groupings. GI, gastrointestinal; OAGB, one-anastomosis gastric bypass; RYGB, Roux-en-Y gastric bypass; SADI, single anastomosis duodeno-ileal bypass (with sleeve gastrectomy); SG, sleeve gastrectomy. Refer to supplementary file “Tri-Staple clinical and geographical citation data.xlsx” for citation details.

The remainder of this dossier is focused on the use of Tri-Staple™ technology in both preclinical or experimental studies (chapter 6) and clinical investigations with human patients (chapter 7). In addition, the use of powered stapling technology to deploy the staples is summarized in Chapter 8.

CHAPTER 6

TRI-STAPLE™ TECHNOLOGY IN PRECLINICAL AND BENCHTOP TESTING

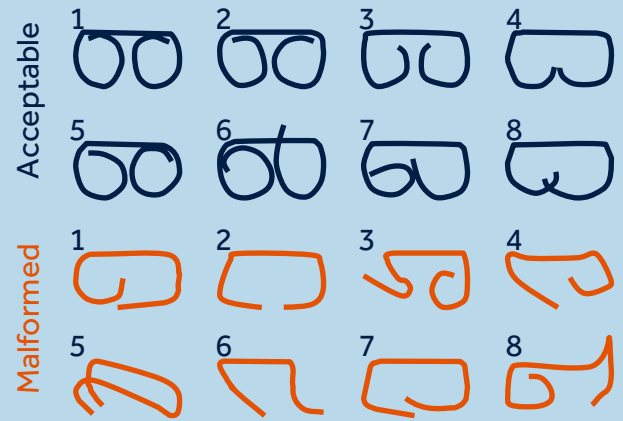

Assessment of proper staple formation

- Tissue clamping
- Stress on vessels in vascular stapling
- Proper staple formation
- Staple-line security
- Tissue perfusion
- Firing speed and variable tissue thickness
- Staple-line reinforcement

6. Tri-Staple™ technology in preclinical and benchtop testing

6.1. Summary and key messages

- **Tri-Staple™ technology is an innovation in stapling devices:** Features include a stepped cartridge face, triple rows of staggered staples on either side of the cut line, graduated heights of staples, and a fixed anvil.
- **Better staple formation‡:** Under conditions of variable tissue thickness, Tri-Staple™ technology yields better rates of proper staple formation than those of single-height staples.³
- **Less tissue pressure and damage†‡:** Tri-Staple™ cartridge technology exhibits less pressure on tissue during clamping[†] and less live tissue bruising in animal models[‡] compared to Echelon Flex GST™* and Endopath™* technologies.^e
- **Less tension increase during stapler firing†:** Tri-Staple™ technology with curved tip reload demonstrated significantly lower increases in tension on synthetic blood vessels during the entire firing sequence than did the Ethicon Powered Vascular Stapler during clamping alone.^f
- **Secure staple-line strength in variable tissue thicknesses‡:** In excised stomach from sleeve gastrectomy patients, Tri-Staple™ technology was associated with higher leak pressure than single-height staples.³⁸
- **Greater tissue perfusion‡:** Tri-Staple™ technology demonstrated greater blood supply to the staple line than single-height staples in an animal stomach model.¹⁰⁸
- **Proper staple formation at varying firing speeds‡:** Although slower firing can increase rates of optimal staple formation over varying tissue thicknesses when using single-height staples,^{3,69} Tri-Staple™ technology has maintained high (over 95%) rates of successful staple formation with both normal and slow firing.³
- **High rates of optimal staple formation with preloaded reinforcement‡:** High rates of proper staple formation with Tri-Staple™ technology are maintained with preloaded reinforcement material.¹¹³

[†]Benchtop test results may not correlate with clinical performance in humans; [‡]Preclinical results may not correlate with clinical performance in humans.

^{e,‡} Internal testing report PCG-026-Rev1, Feb. 2016. Sample sizes determined ad hoc for internal analysis; no independent reference testing standard has been established. Statistical significance determined a priori as p-value < 0.05. Products tested and sample sizes were: Ethicon Endopath Echelon™* Gold (GST60D) n=2, Black (GST60T) n=5, Green (GST60G) n=2, fired with Ethicon Echelon Flex™* Powered Plus Stapler (PSEE60A); Medtronic Tri-Staple™ Purple 60 mm Endo GIA™ reload (EGIA60AMT) n=4, Black (EGIA60AXT) n=5, fired with Medtronic iDrive™ Ultra Powered Handle with linear adapter. Note that bench test results may not be indicative of clinical performance.

^{f,†} Internal testing report RE00128041 (rev 1). Sample sizes determined ad hoc for internal analysis; no independent reference testing standard has been established. P-values from inference testing reported but target threshold for statistical significance undefined. Sample sizes were: Medtronic Tri-Staple™ technology with curved tip reload (clamping only, n=9; clamp+fire+retract, n=16), Ethicon Powered Vascular Stapler (n=18). Powered devices were used (curved tip, tan cartridge: Signia™ stapling system, Ethicon white cartridge, Powered Vascular Stapler). Synthetic vessels of material demonstrated to mimic realistic biological mechanical properties were used to reduce uncontrolled variability in excised animal tissue and to permit tension measurements along axis of the vessel. Note that bench test results may not be indicative of clinical performance.

6.2. Overview

In the following benchtop and preclinical results sections, the features incorporated into Tri-Staple™ technology will be compared to other forms of stapling technology. These comparators include legacy Endo GIA™ reloads, which consist of a flat cartridge face and staples all of equal height, and competitor product Echelon Flex™* staples from Ethicon, which also feature staples of fixed height contained within cartridges of either flat face (Endopath™*) or with so-named gripping-surface technology (GST™*). Additionally, the impact of absorbable buttressing material is experimentally evaluated.

The results are roughly organized according to the stapler firing sequence and subsequent tissue interactions. First, differences in tissue interactions during clamping are assessed (force exerted on tissue and tissue bruising), then the successful formation of staples after deployment (proper B-shape formation in different thicknesses of tissue and at different firing speeds), the security of tissue approximation (leak rates and leak pressure), and vascular perfusion along the staple line.

6.3. Experimental investigations of Tri-Staple™ technology

6.3.1. Tissue clamping

The first step in the stapling process is the securing of the tissue to be approximated. To do so, the tissue is clamped and compressed before the staples are deployed. This clamping of the tissue has the potential to cause damage if too much force is exerted. A design consideration of the Tri-Staple™ cartridge was to reduce pressure during the clamping phase while still allowing proper insertion of staples into the target tissue.

In the absence of an absolute definition of the amount of pressure that should be applied during stapling, in vitro experimental comparisons were made among Echelon Flex GST™*, Echelon Flex Endopath™* and Tri-Staple™ technologies.⁹ The testing was performed using film that is sensitive to the amount of pressure applied on contact, thereby revealing the number of contact points and the maximum pressure exerted when the stapler is clamped. All staple cartridges were mounted on powered stapler systems. The stepped cartridge design of Tri-Staple™ technology was associated with significantly less pressure than both of the Echelon Flex™* devices, with the greatest pressures associated with the more recent Echelon Flex GST™* technology (Figure 6-1).⁹

^{9,†} Internal testing report PCG-026-Rev1, Feb. 2016. Sample sizes determined ad hoc for internal analysis; no independent reference testing standard has been established. Sample measurements were GST n=12, Endopath n=6, Tri-Staple n=4. Statistical significance defined a priori as p-value < 0.05. Test items were Ethicon Endopath Echelon™* green 60 mm GST reload (GST60G) and Ethicon Echelon Reload (ECR60G) fired with Ethicon Echelon Flex™* Powered Plus Stapler (PSEE60A); Medtronic Tri-Staple™ Purple 60 mm Endo GIA™ reload (EGIA60AMT) fired with Medtronic iDrive™ Ultra powered handle with linear adapter. Note that bench test results may not be indicative of clinical performance.

Figure 6-1 Comparison of pressure exerted by clamping with Tri-Staple™ technology versus Echelon Flex GST™* and Endopath™* cartridges

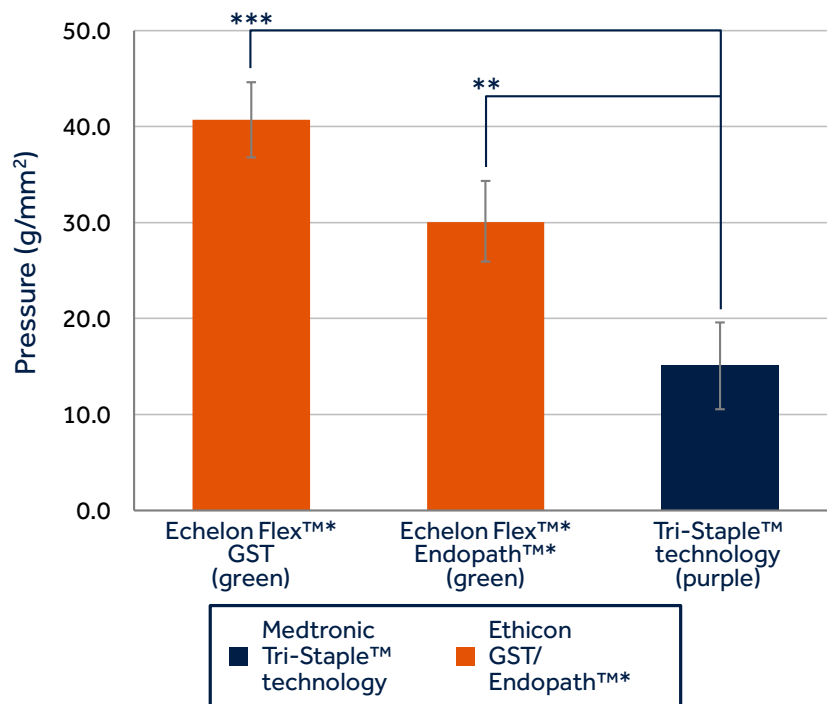

Measured pressure across pressure points of contact between stapler cartridge and pressure-sensitive film. Staplers were subjected to the same 15 seconds of clamping before quantification of images recorded of the resulting film. ** p < 0.01; *** p < 0.001.

Experiments were also conducted to assess effects on live tissue to determine the associated degree of bruising (Figure 6-2).^h Bruising according to a standardized score was measured for clamping of porcine stomach in live specimens after initial clamping (time = 0 minutes) and after tissue had an opportunity to recover (time = 15 minutes).

Across the Tri-Staple™ technology cartridge samples, minimal or no bruising was observed (Figure 6-2).^h In the case of medium tissue thickness staples, the minimal bruising that was initially observed with Tri-Staple™ technology reloads resolved over the 15-minute observation period. In contrast, for the Echelon Flex GST™* samples, the initial tissue reaction (after release of the stapler and observation of the tissue) ranged from minimal bruising to serosal tear with bleeding and the damage did not appear to considerably resolve over time. The results suggest that in living tissue with functioning vasculature, temporary bruising was observed with Tri-Staple™ technology indicating the minimal trauma associated with its clamping of the target tissue.

^{h,†} Internal testing report PCG-026-Rev1, Feb. 2016. Sample sizes determined ad hoc for internal analysis; no independent reference testing standard has been established. Sample measurements were GST n=12, Endopath n=6, Tri-Staple n=4. Statistical significance defined a priori as p-value < 0.05. Test items were Ethicon Endopath Echelon™* green 60 mm GST reload (GST60G) and Ethicon Echelon Reload (ECR60G) fired with Ethicon Echelon Flex™* Powered Plus Stapler (PSEE60A); Medtronic Tri-Staple™ Purple 60 mm Endo GIA™ reload (EGIA60AMT) fired with Medtronic iDrive™ Ultra Powered Handle with linear adapter. Note that bench test results may not be indicative of clinical performance.

Figure 6-2 Comparison of living porcine tissue bruising by clamping with Tri-Staple™ technology versus Echelon Flex GST™* technology

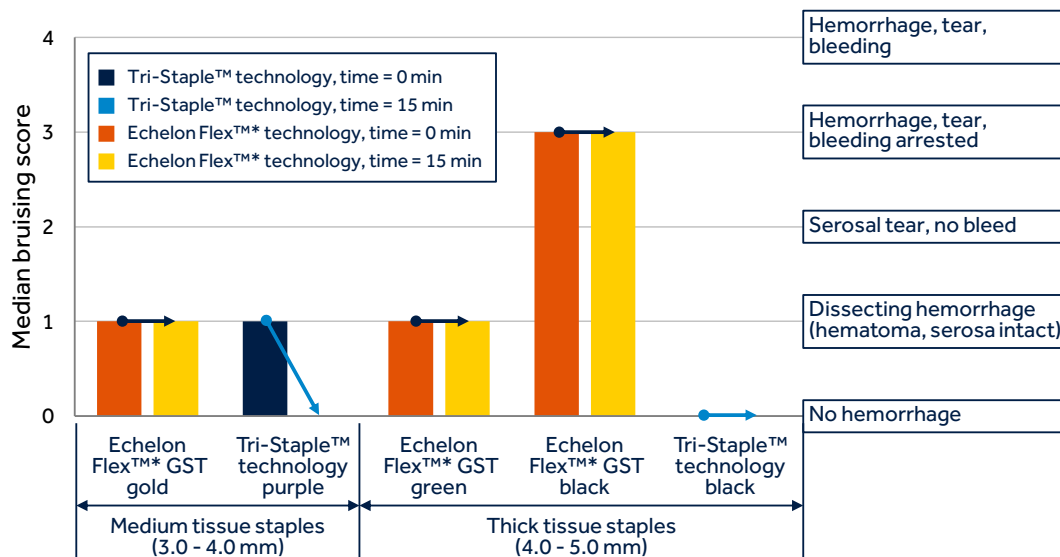

Live porcine stomach tissue bruising was quantified for compression using Tri-Staple™ technology and Echelon Flex GST™* cartridges in medium and thick tissue applications. Bars indicate the median bruising score recorded for samples in each category, and values in parentheses are the respective mean scores. Arrows indicate the change in bruising in each sample over time (from initial contact at time = 0 min to time = 15 min). The definitions of bruising score (0 – 4) are shown at right. Data from an internal testing report.ⁱ

6.3.2. Stress on vessels in vascular stapling

Successful stapling requires capture of the target tissue between the jaws of the device. When stapling blood vessels, securing the tissue may cause unintended stress that may contribute to adverse outcomes.¹⁰⁶ A preclinical study investigated the impact of tension and torsion using porcine pulmonary arteries. The vessels were subjected to different classes of stress that might occur during normal stapler operation: none, lifting of the vessel, twisting of the vessel, or both lifting and twisting (n=10 per group). After stapling, leak pressures were measured using saline solution.¹⁰⁶

The results demonstrated that the application of lifting and/or twisting forces to the vessel during the stapling process was associated with poorer-quality staple lines in the animal model.¹⁰⁶ The vessels that experienced neither lifting nor twisting were resistant to greater fluid pressures than those subjected to lifting and twisting (significant, $p < 0.001$), those subjected to twisting only (significant, $p < 0.001$), and those subjected to lifting only (non-significant). Fewer staple lines in the control group were malformed (1 of 10 samples)

^{i,†} Internal testing report PCG-026-Rev1, Feb. 2016. Sample sizes determined ad hoc for internal analysis; no independent reference testing standard has been established. Statistical significance determined a priori as p -value < 0.05 . Products tested and sample sizes were: Ethicon Endopath Echelon™* Gold (GST60D) n=2, Black (GST60T) n=5, Green (GST60G) n=2, fired with Ethicon Echelon Flex™ Powered Plus Stapler (PSEE60A); Medtronic Tri-Staple™ Purple 60 mm Endo GIA™ reload (EGIA60AMT) n=4, Black (EGIA60AXT) n=5, fired with Medtronic iDrive™ Ultra Powered Handle with linear adapter. Note that bench test results may not be indicative of clinical performance.

compared to the number of distorted staple lines in vessels subjected to lifting or twisting forces or both (10 of 30, inference test not reported).¹⁰⁶

The same study examined clinical records of patients who received pulmonary vascular stapling to evaluate the relationship between the occurrence of adverse events and the stapling factors that may have contributed.¹⁰⁶ In 263 patients undergoing thoracoscopic lung resection, 754 stapler firings were performed of which 9 adverse events deemed to be stapler related were reported (1.2%).¹⁰⁶ Examination of video records revealed the majority of these events (all oozing from the pulmonary artery) was associated with twisting (7 twisting occurrences of 9 adverse events, 78%).¹⁰⁶ Reduction of forces exerted on vessels during stapling was thus recommended by the study as a potential means of reducing the risk of complications.¹⁰⁶

Increased force on blood vessels during the stapler firing sequence is therefore less desirable. One potential source of tension is the mechanism by which the jaws of the stapler close around the vessel. Tri-Staple™ technology features a fixed anvil that remains stationary as the cartridge is brought into proximity while other designs including legacy single-height Endo GIA™ and Ethicon Endopath™* stapler cartridges remain stationary while the anvil is moved into position (Figure 6-3). Benchtop testing has been performed to compare the forces exerted on a synthetic material that mimics arteries during stapling with the two methods (fixed anvil versus fixed cartridge).

Figure 6-3 Fixed versus pivoting anvil design

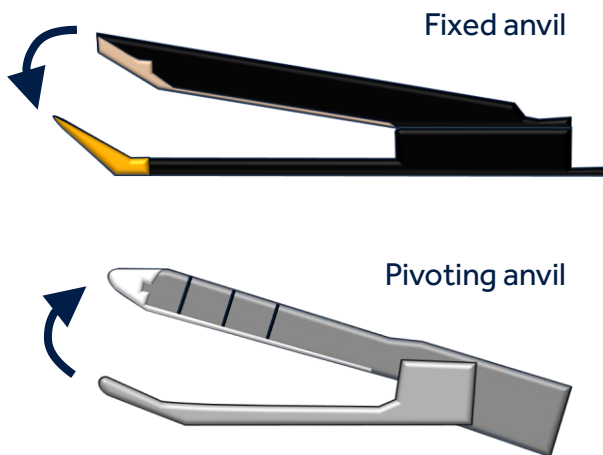

Different cartridge designs. In the fixed anvil design (top) the anvil remains stationary while the cartridge pivots towards it to close the jaws around tissue. In the pivoting anvil design, the cartridge remains stationary and the anvil pivots towards it to complete the closure. Images are for illustration only and are not to scale.

In these benchtop trials,^j synthetic vessels were used that possessed realistic mechanical properties to reduce variation as compared to excised tissue. The testing apparatus was constructed to simulate physiological tension on the vessel and the restricted access channel that might be encountered during surgery. The additional tension exerted on the vessel due to clamping with the fixed anvil design (Tri-Staple™ tan cartridge) was compared to the tension associated with a pivoting anvil design (legacy Endo GIA™ white cartridge). Separate experiments were performed using a similar in vitro setup to compare vessel tension changes between Tri-Staple™ technology with curved tip reloads and the Ethicon Powered Vascular Stapler.^k In these latter experiments, the average tension increases with the Tri-Staple™ technology with curved tip reload during clamping only and during the complete firing sequence were compared to the mean tension increase with the Ethicon Powered Vascular Stapler during clamping only.^j

The results indicate that significantly smaller increases in force (above baseline physiological tension) were associated with the fixed anvil compared to the pivoting anvil design (Figure 6-4). Compared to the legacy Endo GIA™ pivoting anvil cartridge, the fixed anvil Tri-Staple™ technology reload resulted in a 92% smaller increase in vessel tension during clamping. The separately performed experiments to compare Tri-Staple™ technology with curved tip (fixed anvil) and the Ethicon Powered Vascular Stapler (pivoting anvil) yielded similar results, demonstrating significantly greater vessel tension increase during clamping with the Ethicon device versus the Medtronic (Figure 6-5). For clamping only, the Tri-Staple™ technology with curved tip caused a tension increase on the vessel 94% lower than clamping with the Ethicon Powered Vascular Stapler under similar experimental conditions. When considering tension increase over the entire firing sequence (clamping, firing, and retraction), the fixed anvil, curved tip with Tri-Staple™ technology device generated a 49% lower increase in vessel tension than that caused by the Ethicon Powered Vascular Stapler during clamping alone.

^{j,†} Internal testing reports RE00224301 (results, version Sept. 2019), RE00128041 (protocol, version Jan. 2018). Sample sizes determined ad hoc for internal analysis; no independent reference testing standard has been established. P-values from inference testing reported but target threshold for statistical significance undefined. Products tested and sample sizes were: Medtronic Endo GIA™ articulating loading unit 60 mm white (n=10) and Endo GIA™ articulating loading unit 60 mm Vascular/medium (tan, n=10). Staples in both groups were fired with Medtronic Signia™ Powered Handle. Note that bench test results may not be indicative of clinical performance.

^{k,†} Internal testing report RE00128041 (rev 1). Sample sizes determined ad hoc for internal analysis; no independent reference testing standard has been established. P-values from inference testing reported but target threshold for statistical significance undefined. Sample sizes were: Medtronic Tri-Staple™ technology with curved tip reload (clamping only, n=9; clamp+fire+retract, n=16), Ethicon Powered Vascular Stapler (n=18). Powered devices were used (curved tip, tan cartridge: Signia™ stapling system, Ethicon white cartridge, Powered Vascular Stapler). Synthetic vessels of material demonstrated to mimic realistic biological mechanical properties were used to reduce uncontrolled variability in excised animal tissue and to permit tension measurements along axis of the vessel. Note that bench test results may not be indicative of clinical performance.

Figure 6-4 Tension exerted on synthetic vessels during stapling from fixed versus pivoting anvil designs

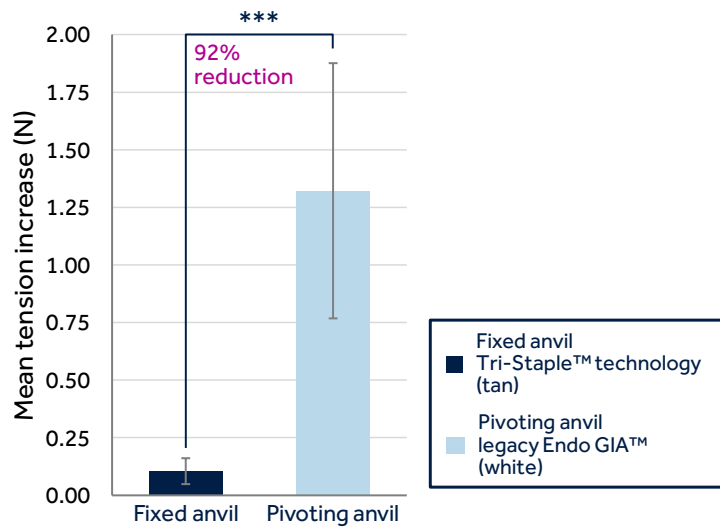

Data from internal testing report RE00224301¹ for measurement of additional tension on synthetic vessels during stapling with a fixed anvil design (Tri-Staple™ technology, tan reload) versus a pivoting anvil design (legacy Endo GIA™, white reload) both fired with the Signia™ stapling system. *** p < 0.001; N, newtons.

^{1,†} Internal testing reports RE00224301 (results, version Sept. 2019), RE00128041 (protocol, version Jan. 2018). Sample sizes determined ad hoc for internal analysis; no independent reference testing standard has been established. P-values from inference testing reported but target threshold for statistical significance undefined. Products tested and sample sizes were: Medtronic Endo GIA™ articulating loading unit 60 mm white (n=10) and Endo GIA™ articulating loading unit 60 mm Vascular/medium (tan, n=10). Staples in both groups were fired with Medtronic Signia™ Powered Handle. Note that bench test results may not be indicative of clinical performance.

Figure 6-5 Tension exerted on synthetic vessels during stapling by Tri-Staple™ technology with curved tip reloads versus Ethicon Powered Vascular Stapler

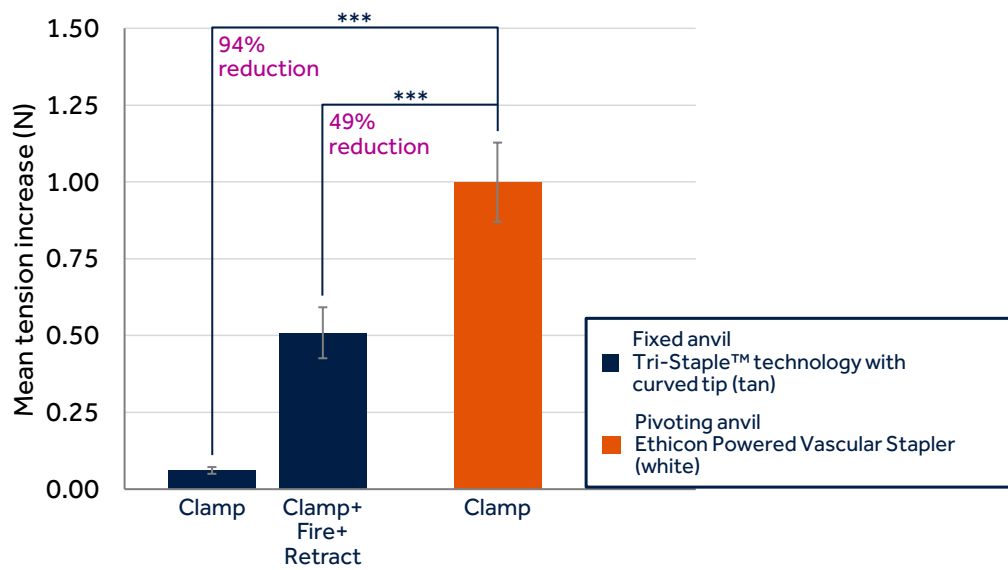

Data from internal testing report RE00128041^m for measurement of additional tension on synthetic vessels during stapling with a fixed anvil design (Tri-Staple™ technology with curved tip) versus a pivoting anvil design (Ethicon Powered Vascular Stapler). *** $p < 0.001$; N, newtons.

^{m,t} Internal testing report RE00128041 (rev 1). Sample sizes determined ad hoc for internal analysis; no independent reference testing standard has been established. P-values from inference testing reported but target threshold for statistical significance undefined. Sample sizes were: Medtronic Tri-Staple™ technology with curved tip reload (clamping only, n=9; clamp+fire+retract, n=16), Ethicon Powered Vascular Stapler (n=18). Powered devices were used (curved tip, tan cartridge: Signia™ stapling system, Ethicon white cartridge, Powered Vascular Stapler). Synthetic vessels of material demonstrated to mimic realistic biological mechanical properties were used to reduce uncontrolled variability in excised animal tissue and to permit tension measurements along axis of the vessel. Note that bench test results may not be indicative of clinical performance.

6.3.3. Proper staple formation

To prevent blood or other fluid loss and promote wound healing, successful tissue approximation with staples relies on appropriate formation of the staple line. An important component thereof is the proper formation of the staples as they are passed through the tissue. Proper staple formation is indicated by the desired “B” shape, as incorporated in the first staple designs.² Flattened or over crimped staples are undesirable.⁷⁴ For analysis of proper staple formation, staples deployed during a procedure (in animal tissue or a synthetic material) can be recovered to assess the staple shape according to scoring criteria (see section 3.4.2).

The stomach naturally consists of variable tissue thicknesses along its greater curvature.³³ This feature makes this organ a useful model in suitable animals (often porcine) for examination of staple formation for varying thicknesses. The variable, or graduated, staple height design of Tri-Staple™ technology was designed to improve rates of successful staple formation in varying tissue applications in comparison to single-height staples. Tri-Staple™ technology, in comparison to legacy Endo GIA™ (green cartridge), has been associated with higher rates of proper staple formation (Figure 6-6).³

Figure 6-6 Successful staple formation with Tri-Staple™ technology versus single-height staples in a porcine model

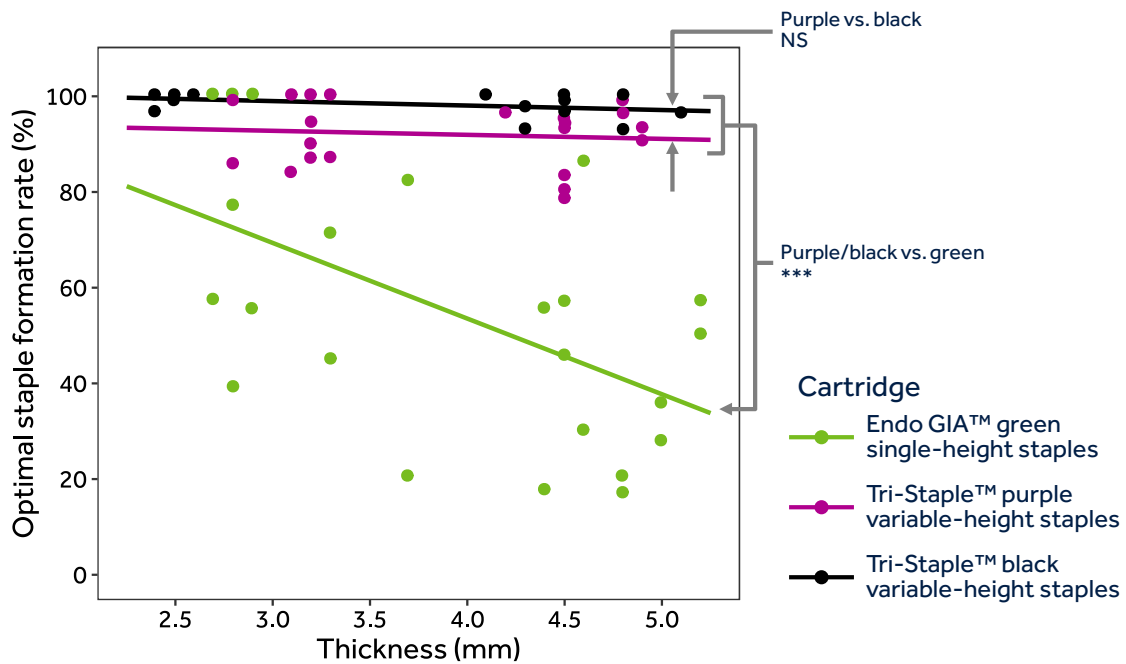

Data are shown from the study of Hasegawa et al., 2015 assessing proportion of properly formed staples according to tissue thickness along porcine stomach.³ The variable-height Tri-Staple™ technology cartridges (purple, black) are shown to have considerably higher proportions of proper staple formation in comparison to the legacy single-height (Endo GIA™ green) cartridge staples. ***** $p < 0.001$.

6.3.4. Staple-line security

Appropriate staple formation after clamping and firing is a key component in the creation of an adequate staple line in the target tissue. Preclinical experiments with Tri-Staple™ technology have been performed to test the security of the tissue approximation through measurement of leak rates along newly-created staple lines. In one example performed in porcine lung, comparisons were undertaken between single- and variable-height staples to determine the rates of leaks that result from insufflation at different pressures.¹¹⁴ At the two different pressures tested (30 and 40 cm H₂O), lower rates (not statistically significant) of detectable leaks were measured with the lung samples treated with Tri-Staple™ technology compared to legacy, single-height Endo GIA™ staples (Figure 6-7). Note that the indicated leak rates may not translate directly to human patients.

Figure 6-7 Pulmonary tissue leak rates under in vivo conditions compared between Tri-Staple™ technology and single-height staples

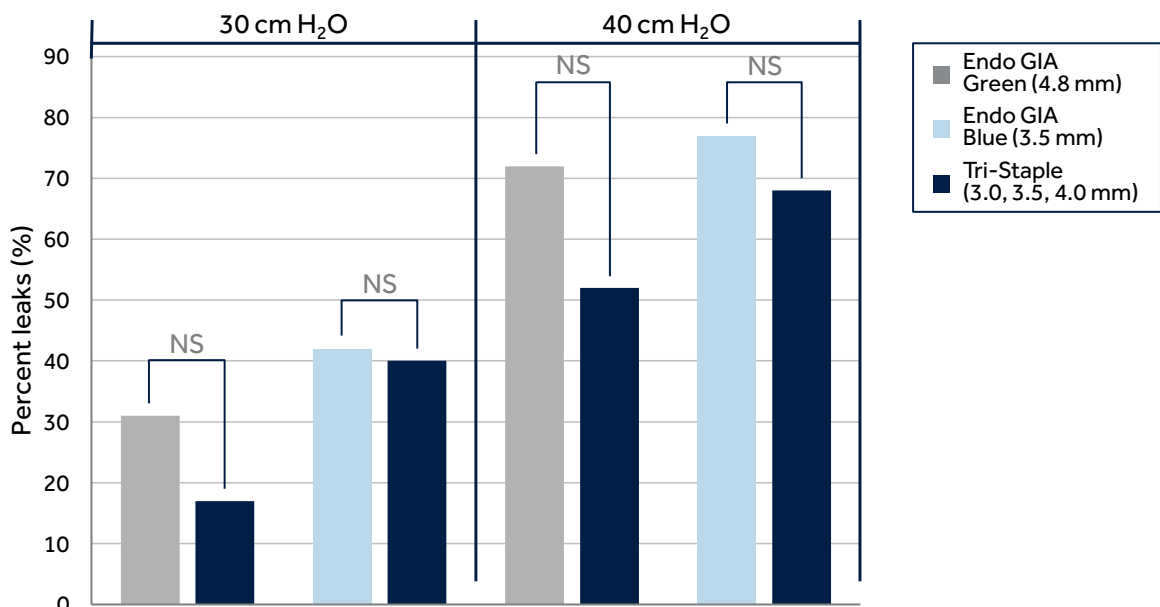

Data from Contini et al., 2013 comparing legacy (Endo GIA™ green and blue cartridge) stapling technology of single-height staples with variable height (Tri-Staple™ technology) in pulmonary animal models.¹¹⁴ The cartridges used are shown at right, along with the corresponding staple heights. Results are stratified according to insufflation pressures (in cm H₂O). NS, non-significant.

The staple line created after laparoscopic sleeve gastrectomy in human patients was compared between those managed with single-height staples (legacy Endo GIA™ blue/green cartridges, n = 35 patients) versus Tri-Staple™ technology (purple cartridges, n = 35 patients).³⁸ During the surgery, complete resection is achieved via sequential firings to divide the greater curvature of the stomach leaving a tube-like sleeve. The excised portion was tested with injected saline to determine the pressure required to produce leaks. The results were compared between the two types of staples. The stomach samples from patients whose surgery used Tri-Staple™ technology were associated with significantly higher pressures required to produce the first leak compared to those managed with legacy single-height staples (Figure 6-8). Note that although the results were obtained in tissue from human subjects, the leak pressures may not correspond directly to those that would occur in those patients. Separate staple lines are generated on the other side of the cut line

that remains in the patient; the anatomy of the lesser curvature of the stomach is different than that of the dissected greater curvature. These differences could influence the leak pressure that would result, given the greater distensibility of the removed portion compared to the remaining sleeve.¹¹⁵

Figure 6-8 Leak pressure in stomach excised from patients undergoing sleeve gastrectomy

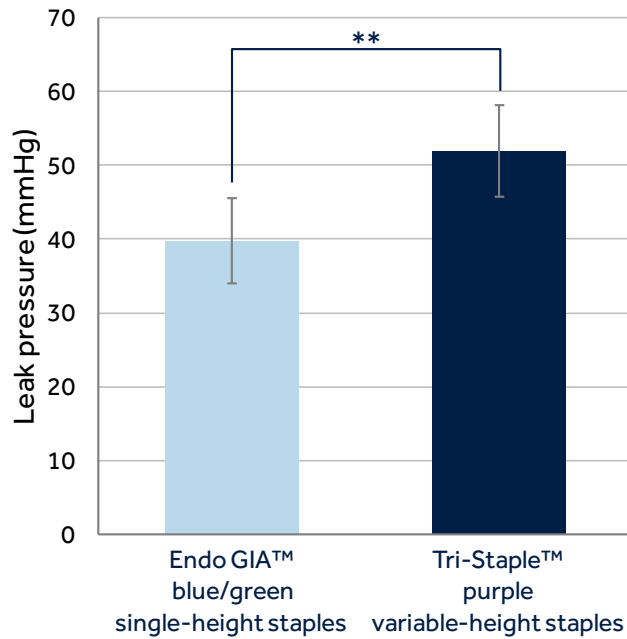

Data are shown from in vitro experiments performed on the excised stomach fragments from patients (n = 35 in each group) undergoing sleeve gastrectomy surgery.³⁸ Saline was injected into the excised stomach and the pressure required to generate a leak measured. ** p < 0.01.

6.3.5. Tissue perfusion

Early staple design advocated the “B” staple shape to allow for blood perfusion near the approximated tissue.² This design feature acknowledged the importance of maintaining blood flow in the region of the staple line to aid in tissue recovery.

Tri-Staple™ technology was in part designed to improve perfusion around the staple line, and this design principle has been supported by experimentation in an animal model examining the volume of vascularization among the staples in the staple line.¹⁰⁸ Analysis of images recorded of the staple line to measure the degree of vascularization suggested significantly greater volume in tissue sealed with Tri-Staple™ technology compared to single-height (Ethicon Echelon Flex™* Endopath™*) staples (Figure 6-9).¹⁰⁸ Thus, beyond the standard incorporation of the B-shaped staple formation, the graduated staple height from across the three rows of staggered staples on either side of the cut line is also associated with increased vascular supply to the approximated tissue.¹⁰⁸

Figure 6-9 Measured vascular volume incorporated in the staple line in Tri-Staple™ technology versus single-height staples

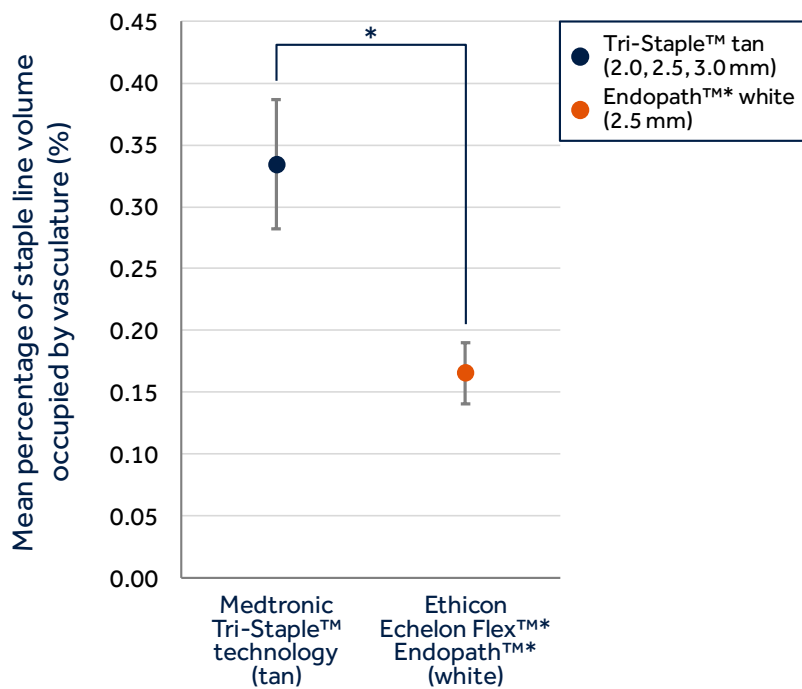

Data are shown from the study of Eschbach et al., 2018 comparing staple line vascularization between graduated-height (Tri-Staple™ technology tan cartridge, n=12 samples) and single-height (Ethicon Echelon Flex™* Endopath™* white cartridge, n=14) staples in a rat model of subtotal gastrectomy.¹⁰⁸ Quantification of the volume around the staples occupied by blood flow revealed significantly greater vascularization volume in the Tri-Staple™ technology samples compared to that of the single-height samples. * p < 0.05.

6.3.6. Firing speed and variable tissue thickness performance

As shown above (section 6.3.3), Tri-Staple™ technology has been shown to create higher rates of properly formed staples even in cases of variable tissue thickness. An additional contributor to successful staple formation is the rate of firing. Researchers have noted that in some applications, notably pancreatic operations, techniques include longer tissue clamping time and slower stapler firing to improve outcomes.^{47,49,69}

This slower stapler firing effect has been shown in a study on stomach tissue in a porcine model comparing proper staple formation rates between variable-height Tri-Staple™ technology and legacy Endo GIA™ single-height staple technology, all deployed using the Endo GIA™ endoscopic linear stapler (Figure 6-10).³ For the single-height staples (green cartridge reload), decreasing the speed of stapling greatly increased the rate of proper staple formation across the range of tissue thicknesses sampled. Using Tri-Staple™ technology, the effect of speed was somewhat lessened (Figure 6-10). The results demonstrate the performance of Tri-Staple™ technology in achieving high rates of proper staple formation (over 95%) even across varying tissue thicknesses and at different firing speeds (Figure 6-10). The results further indicate, however, that the firing technique (that is, speed of stapling) may influence outcomes dependent on proper staple formation.

Figure 6-10 The impact of stapler firing speed on proper staple formation in tissue of varying thickness

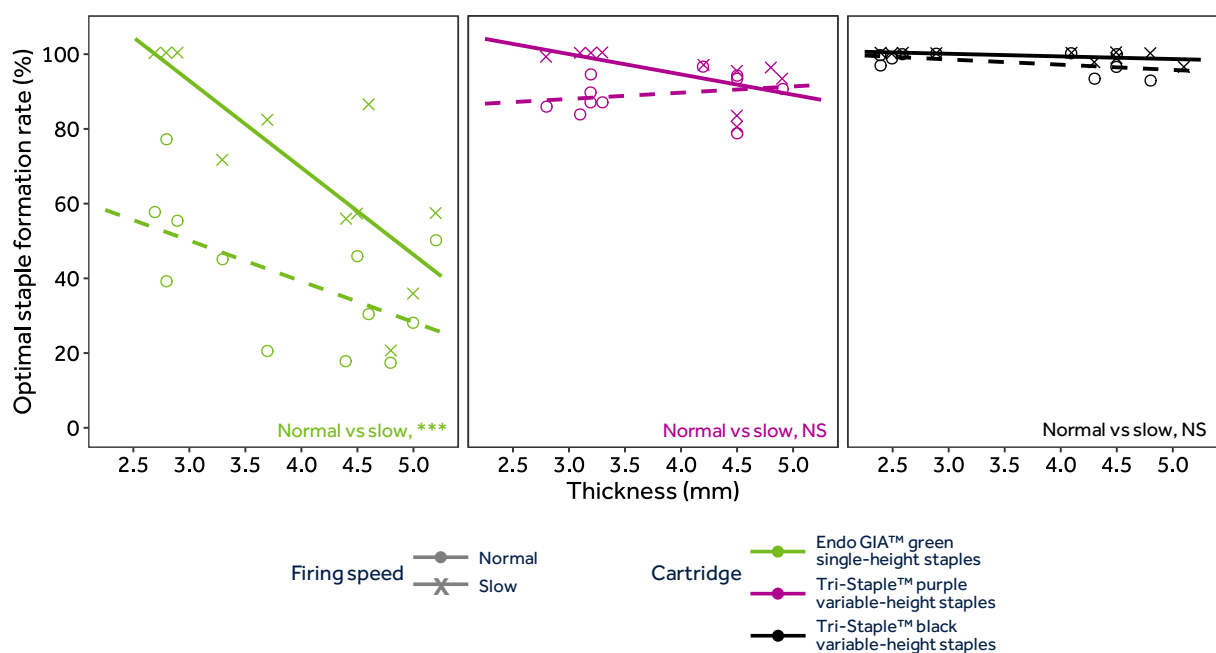

Data are shown from the study of Hasegawa et al., 2015 of successful staple formation rates compared between single-height staples (Endo GIA™ green cartridge) and Tri-Staple™ variable-height staple technology (black) for different thicknesses of porcine stomach tissue at different speeds.³ Slower firing is associated with greater proportions of properly-formed staples, but the effect is primarily seen in the single-height (green) case.

A separate study also in a porcine model similarly found an effect of stapling technique on rates of proper staple formation.⁶⁹ In that case, staples of single-height were used (Echelon Flex™* powered Endopath™* stapler with gold reloads), and results were stratified according to compression time (time during which tissue is clamped before firing) and stapling time (time during which staples are deployed in the tissue) for samples of porcine stomach (Figure 6-11). The authors noted a similar increase in the rate of proper staple formation with compression time greater than zero and with increasing staple firing time; under the reported experimental conditions however, the optimal formation rate ranged lower (61%–75%) than that of similar experiments using Tri-Staple™ technology with slow firing (black reload, 97%–100%; purple reload 81%–100%, Figure 6-10)³ in porcine tissue of varying thickness.

Figure 6-11 Impact of stapler compression time and firing rate impact on optimal staple formation

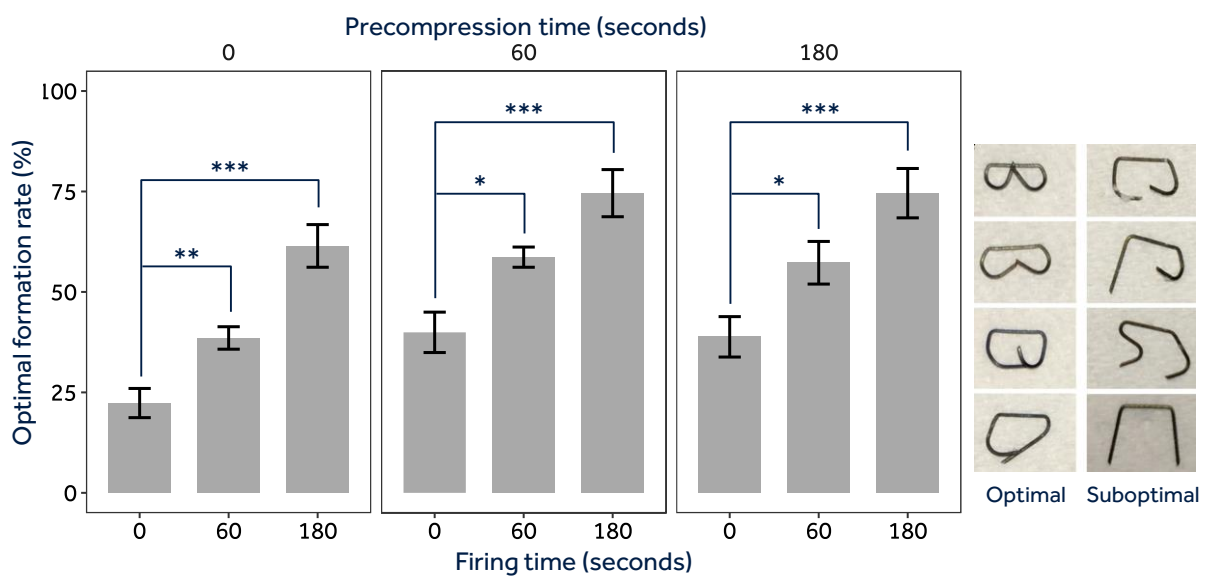

Results are shown for stapler firing (Echelon Flex™* Endopath™* with gold reload) in porcine tissue according to varying tissue precompression time (defined as the time between the closing and locking of the stapler and the start of firing) and time taken to fire the stapler.⁶⁹ At right are examples shown of recovered staples included in the “optimal” and “suboptimal” staple formation grouping; refer to Figure 3-5 and Figure 3-6 for comparison. Bars indicate means, and error bars standard deviation. * p < 0.05; ** p < 0.01; *** p < 0.001.

6.3.7. Staple-line reinforcement

In some surgical applications, the staple line used to approximate tissues may further benefit from additional reinforcement (see Section 3.6). Depending on the analysis, surgical application, and type of reinforcement, studies have shown decreases in leaks^{11,77,97} and bleeding^{30,97} with reinforcement compared to non-reinforcement. Among the available options for reinforcement, the use of absorbable membrane on the stapler cartridge face has shown reduced rates of leak after sleeve gastrectomy (see Figure 3-7).^{11,97} The usual goal of reinforcement is to strengthen the staple line with the aim of reducing complications,^{97,116} but the addition of reinforcement material itself may affect the deployment of the staples. In vitro experimentation has been performed to assess the impact of preloaded reinforcement material (using Tri-Staple™ technology with reinforced reload) on the rate of proper staple formation.¹¹³ In a porcine model, complete staple formation rates were compared in thicker stomach tissue and thinner colonic tissue between Tri-Staple™ technology with and without preloaded reinforcement material (Figure 6-12).¹¹³ Small, statistically-significant increases were associated with the use of the reinforced staples ($p < 0.05$). All groups exhibited the high (>90%) rates of successful staple formation that have been observed in this, and other preclinical studies.^{3,74}

Figure 6-12 Comparison of proper staple formation rate between Tri-Staple™ technology alone versus Tri-Staple™ technology with reinforced reload

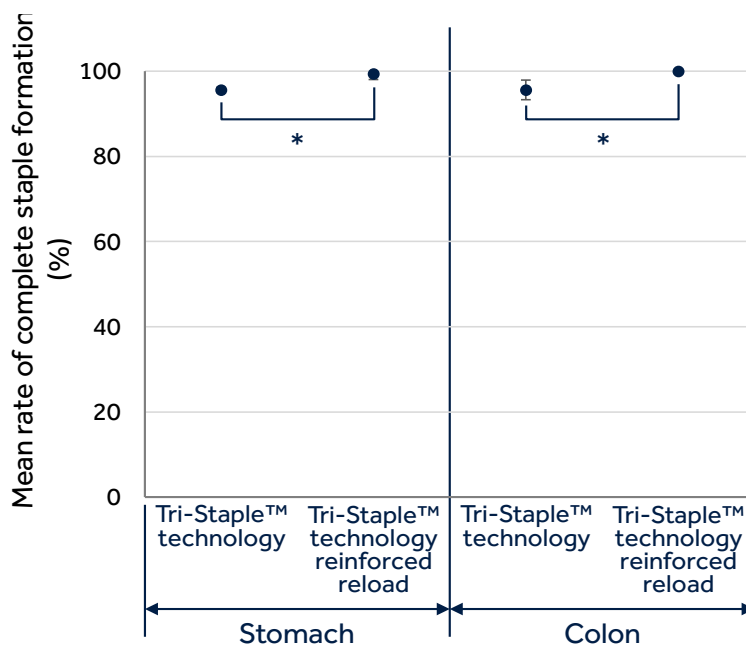

Data shown are from Naito et al., 2017 where proper staple formation rates were determined for stomach and colon porcine tissue sealed with Tri-Staple™ technology alone and with reinforced reload (preloaded absorbable reinforcement material).¹¹³ Staples were assessed from three trials of firing, but the number of staples evaluated from each trial was not reported. * $p < 0.05$.

CHAPTER 7

CLINICAL APPLICATIONS OF TRI-STAPLE™ TECHNOLOGY

- Pulmonary
- Gastric
 - Bariatric and metabolic surgeries
 - Gastrectomy
- Colorectal resection
- Other surgical areas
 - Pancreatic resection
 - Hepatic resection

7. Clinical applications of Tri-Staple™ technology

7.1. Summary and key messages

- **Broad clinical applications:** Tri-Staple™ technology has been successfully applied in a variety of surgical areas including bariatric procedures,^{38-40,56} and resections of the lung,^{4,41,42} stomach,^{43,44} colon,^{35,45} pancreas,⁴⁶⁻⁵² and liver.²²
- **Significantly lower complications in bariatric surgery:** Significantly lower odds of leak occurrence after sleeve gastrectomy have been reported for Tri-Staple™ technology use after sleeve gastrectomy compared to single-height staples.³⁹ Significantly lower postoperative nausea and vomiting rates have been reported for Tri-Staple™ technology with reinforced reload compared to suture reinforcement of the staple line.⁴⁰
- **Reinforcement can significantly reduce bleeding incidence:** Tri-Staple™ technology with reinforced reload has been associated with significantly lower incidence of bleeding after gastrectomy.⁴⁴
- **Fewer complications in pulmonary resection:** Tri-Staple™ technology was associated with non-significantly lower pulmonary complications after resection compared to single-height staples.⁴ Furthermore, the use of Tri-Staple™ technology with reinforced reload has significantly reduced complication rates compared to Tri-Staple™ alone.^{41,42}
- **Lower to comparable rates of complications after pancreatic resection:** Reported rates of clinically-relevant postoperative pancreatic fistula with Tri-Staple™ technology^{46,49} are comparable to or lower than those reported globally across non-specified closure methods.^{20,64-66} Rates with reinforced reloads^{46-48,50,51} are similarly lower or comparable to general closure methods^{20,65} and bare staples.^{46,50,66}
- **Reinforcement can reduce leak incidence:** Use of Tri-Staple™ technology with reinforced reload has been associated with reduced incidence of air leaks^{41,42} compared to non-reinforced Tri-Staple™ technology.
- **Reinforcement can reduce pancreatectomy complications:** Use of Tri-Staple™ technology with reinforced reload has been associated with significantly^{46,51} and non-significantly⁵⁰ lower rates of postoperative pancreatic fistula after distal pancreatectomy.

7.2. Overview

As described previously, stapling technology in general and Tri-Staple™ technology in particular, has been applied to a variety of surgical areas (see sections 3.4.5 and 5.4). The results in this chapter are subdivided by general surgical area to present clinical results associated with the use of Tri-Staple™ technology in humans.

7.3. Pulmonary

Pulmonary surgeries can include any procedure involving lung tissue (wedge resection, segmentectomy, lobectomy, fissure dissection),^{41,42,59} adjacent anatomy (bronchial tube

closure after lobectomy),^{4,117} and pulmonary vessels.¹¹⁸ Surgical stapling has been used in these various surgeries.^{4,41,42,117}

The performance of Tri-Staple™ technology compared to legacy single-height staples has been assessed in pulmonary tissue in a randomized trial.⁴ Patients indicated for upper or lower lobectomy were randomized to treatment with legacy single-height staple cartridges (Endo GIA™ blue) or to treatment with Tri-Staple™ technology (purple). Staple formation quality was assessed on the excised tissue by independent surgeons blinded to the treatment group.⁴ On the staple line remaining in the patient, outcomes were assessed by visual inspection of the staple line during an air inflation test under pressure of 10-20 cm H₂O.⁴ The intent of such evaluation was to provide insight into staple and seal quality on both sides of the staple line in patients undergoing lobectomy. The results indicated both significantly and non-significantly improved outcomes with Tri-Staple™ technology compared to legacy, single-height staples. On the staple-line side in the excised tissue, significantly higher staple formation quality was observed in patient tissue managed with Tri-Staple™ technology compared to legacy single-height staples (Figure 7-1).

Staple formation cannot be assessed on the patient side, since the staples must remain in the tissue to complete the staple line. Instead, authors visually inspected the development of complications on application of pressure (gross appearance, bleeding or oozing, dehiscence, and occurrence of air leak under pressure of 10-20 cm H₂O). The legacy staple lines were associated with non-significantly more intraoperative complications (air leaks and oozing on application of pressure) than the Tri-Staple™ technology staple lines (Figure 7-2).

Figure 7-1 Evaluation of staple formation quality in excised pulmonary tissue in patient lobectomy

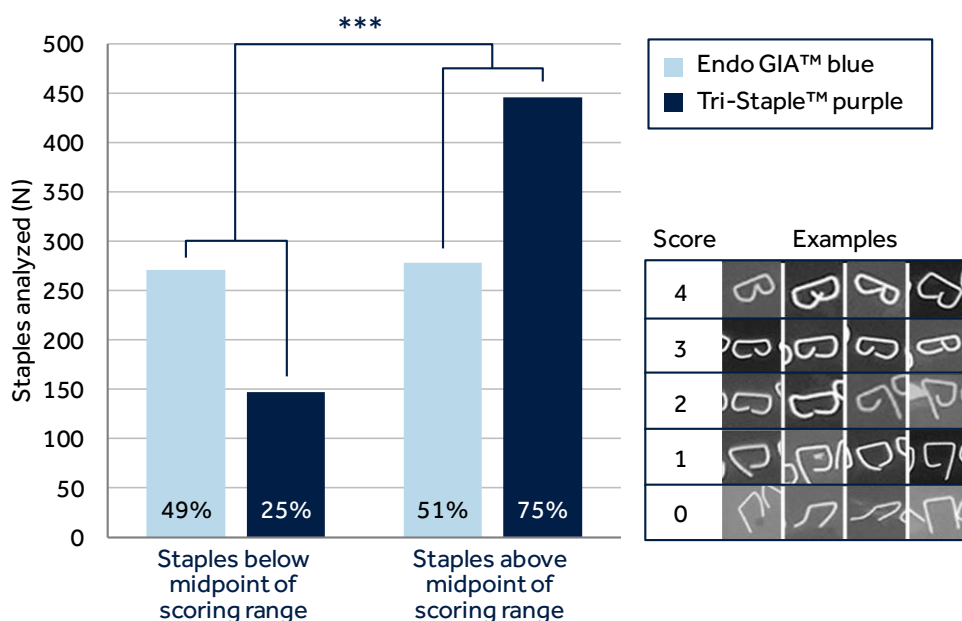

Data from Okami et al., 2017 are shown for the evaluation of staple formation quality on the side of the excised lung tissue.⁴ Results as presented in the publication (Figure 4A) are here presented as the number of staples (and proportion in each treatment group) that were scored above and below the middle of the range of staple quality scores (scale from 0 to 4) by blinded, independent surgeons. Significance was determined by a Chi-squared test, suggesting significantly more staples in the Tri-Staple™ technology treatment group were scored above the median value compared to the legacy single-height staple group. Examples of the staple scoring are shown at right. ***, p < 0.001.

Figure 7-2 Evaluation of staple-line security on patient side of lobectomy

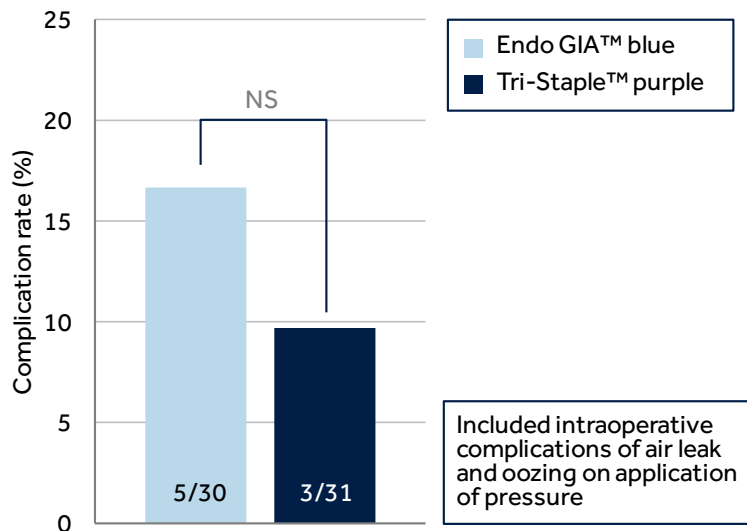

Data from Okami et al., 2017 are shown for the evaluation of complications on the patient-side staple line when pressure was applied (10-20 cm H₂O).⁴ Bars indicate the proportion of patients in each group who had any intraoperative complication (major or minor air leak, oozing) while values displayed on the bars show the numbers of patients with complication over the total number of patients in the corresponding group. NS, non-significant.

The effect of addition of preloaded buttressing material in the form of Tri-Staple™ technology with reinforced reload has also been investigated. The authors of a retrospective study (Deguchi et al., 2019) of patients at a single institution who underwent radical lobectomy performed propensity score matching to reduce the effect of confounding variables between patients managed with Tri-Staple™ technology alone (n=125) and those with reinforced reloads (n=125).⁴² The results indicated an association with reduced complications for Tri-Staple™ technology with reinforced reload compared to Tri-Staple™ technology alone (Figure 7-3).⁴² The pulmonary complications assessed included pneumonia, bronchopleural fistula, acute respiratory distress syndrome, any postoperative air leak, and prolonged postoperative air leak (defined as leak lasting longer than 7 days). The use of Tri-Staple™ technology with reinforced reload was associated with significantly lower incidence of general pulmonary complications and any postoperative air leak. Logistic regression analysis found that the odds of postoperative air leakage were significantly lower with Tri-Staple™ technology with reinforced reload compared to non-reinforced staples (odds ratio 0.38 corresponding to a 2.6-fold decrease, p = 0.015). The decrease in incidence of prolonged air leak for Tri-Staple™ technology with reinforced reload compared to Tri-Staple™ technology alone was not significant between the two reloads. The incidence of chest-tube requirement between the two groups was not reported, but the total duration was non-significantly different.

Another retrospective analysis (Shigeeda et al., 2019) with propensity score-matched patients undergoing pulmonary resection was performed in which similar clinical outcomes were assessed.⁴¹ Of 291 patients who underwent pulmonary wedge resection, 104 propensity score-matched pairs were generated for analysis. The use of Tri-Staple™ technology with reinforced reload was associated with significantly reduced risks of postoperative air leak and need for chest tube placement compared to patients who had been managed with non-reinforced staples (Figure 7-4).⁴¹ The mean duration of chest tube placement was also significantly shorter in the Tri-Staple™ technology with reinforced

reload group compared to the non-reinforced group (0.7 ± 1.0 days versus 1.1 ± 1.3 days, $p = 0.002$). Closer examination of factors influencing risk of air leak revealed that, of the patient parameters assessed, only the use of Tri-Staple™ technology with reinforced reload had a significant association with not experiencing postoperative air leak (8.5-fold greater odds, Figure 7-5).

Together, the studies show an association of reinforced reload use with decreased risk of postoperative air leak and requirement for chest tube placement, and a non-significantly decreasing trend towards prolonged air leak lasting longer than 7 days compared to non-reinforced staples.^{41,42}

Figure 7-3 Tri-Staple™ technology alone versus Tri-Staple™ technology with reinforced reload for complications after pulmonary resection

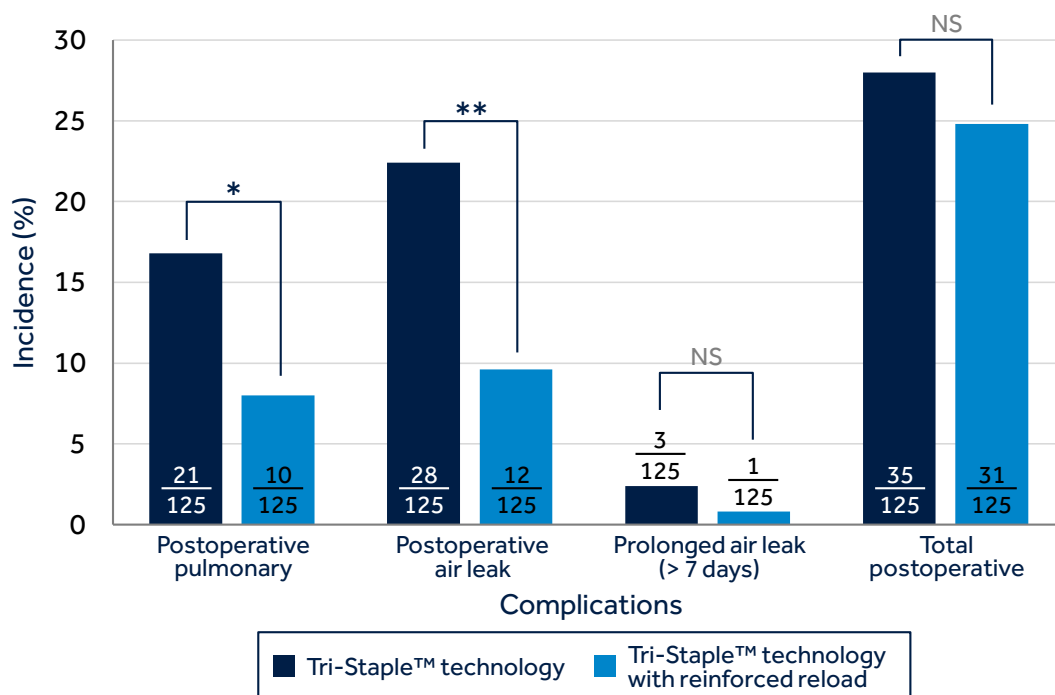

Data⁴² are shown from Deguchi et al., 2019 in a propensity-matched study of patients undergoing pulmonary resection with Tri-Staple™ technology alone and with reinforced reload. Bars indicate the proportions of patients and the values indicate the number of patients divided by the total number of patients. * $p < 0.05$; ** $p < 0.01$; NS, non-significant.

Figure 7-4 Tri-Staple™ technology alone versus Tri-Staple™ technology with reinforced reload for complications after pulmonary resection

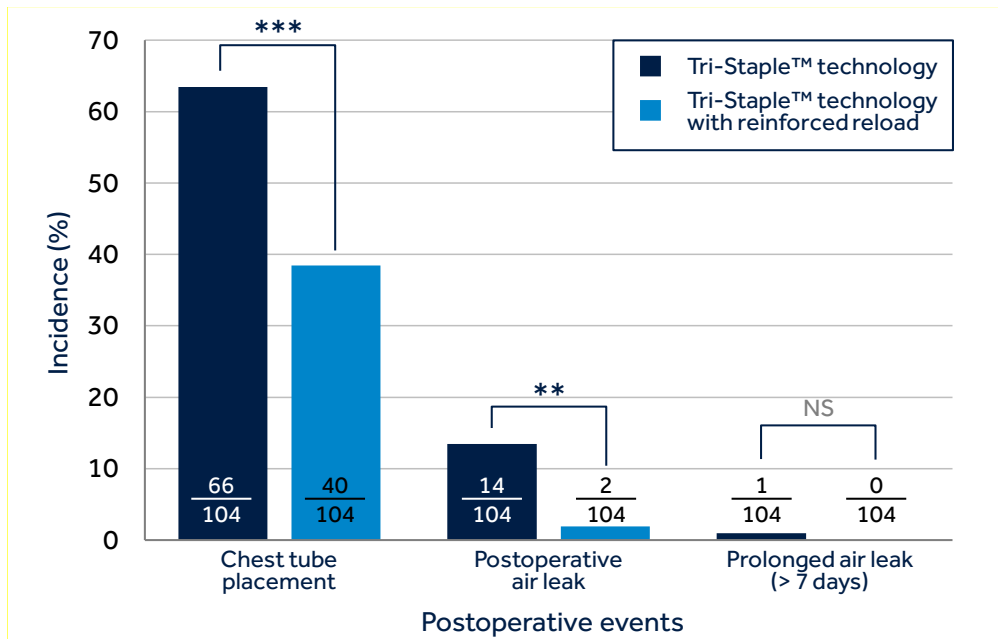

Data are shown from Shigeeda et al., 2019 in a propensity-matched study of patients undergoing pulmonary resection with Tri-Staple™ technology alone and with reinforced reload.⁴¹ Bars indicate the proportions of patients and the values indicate the number of patients divided by the total number of patients. ** p < 0.01; *** p < 0.001; NS, non-significant.

Figure 7-5 Odds ratios for parameters associated with no postoperative air leak

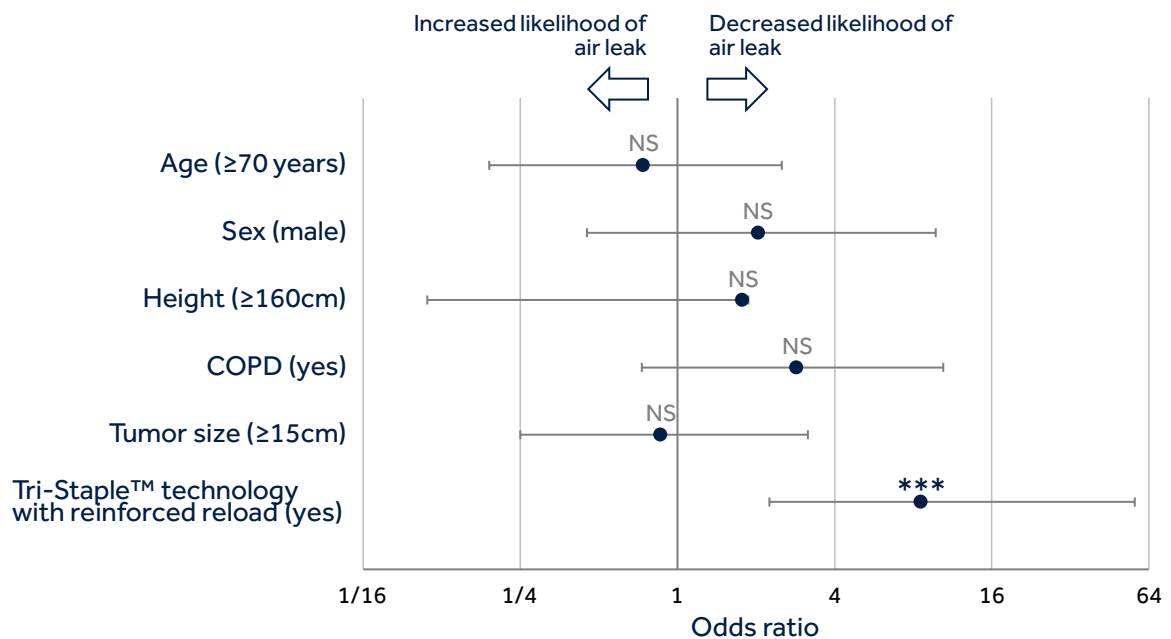

Odds ratios are shown from the study⁴¹ of Shigeeda et al., 2019 regarding the development of postoperative air leak. Values to the right of 1 indicate a decreased likelihood of air leak, those to the left an increased likelihood of air leak. Of the patient parameters assessed, only the use of Tri-Staple™ technology with reinforced reload had a significant association (8.5-fold greater odds) of not experiencing postoperative air leak. COPD, chronic obstructive pulmonary disease; *** p < 0.001; NS, non-significant.

7.4. Gastric

The relevant operations that require modification of the stomach include those related to metabolism and those focused on the removal of tissue, for example, if diseased. In the metabolic group, surgeries are intended for treatment of obesity¹¹⁹ or metabolic diseases such as type 2 diabetes¹²⁰ and involve the removal or redirection of normal tissues. Otherwise, in cases of resection, diseased tissue may need to be removed as in the case of gastric cancer.¹²¹ Tri-Staple™ technology has been used extensively in gastric procedures, as outlined below.

7.4.1. Bariatric and metabolic surgeries

A variety of options is available for bariatric or metabolic surgery. They differ in typical degree of weight loss attained (in the case of bariatric surgery) or success in resolution of type 2 diabetes mellitus (in the case of metabolic surgery) and in the associated complications.^{119,122} Common procedures include Roux-en-Y gastric bypass (RYGB) and sleeve gastrectomy (SG); newer modifications such as one-anastomosis gastric bypass (OAGB) are also performed with frequencies varying according to geographical region.^{n,123}

Among these procedures, sleeve gastrectomy, in which a large portion of the stomach is removed, is one in which stapling is prominently featured (see Table 3-5, Table 5-1), but stapling has also been used for anastomosis-creation in other types of bariatric surgery.¹²⁴

With the alterations to the normal flow of the gastrointestinal tract that result from bariatric surgery, one complication that can occur after the procedure is leakage of gastric fluids.^{101,121} Additionally, bleeding around the staple line and stenosis of the closed structure are complications often studied.^{43,121} Closure methods, primary and reinforcement, are focused on minimization of the risk of such complications (recall section 3.4.1 and section 4.5).

In a preclinical study of Tri-Staple™ technology use in sleeve gastrectomy patients, the results of experiments performed on the removed portion of stomach suggested that Tri-Staple™ technology may provide closure more resistant to leak than single-height staples.³⁸ The results provided only an indication of potential patient outcomes, however, since they tested the staple line on the side of the excised tissue for resistance to leak pressure, and not the staple line that remained in patient tissue (see section 6.3.4, Figure 6-8).

For the assessment of leak after sleeve gastrectomy in the clinical setting, one study examined risk factors for development of staple line leaks in a retrospective cohort of 1,041 sleeve gastrectomy procedures.³⁹ Leaks occurred in 24 patients (2.31%), and these patients were compared to those who did not have leaks across demographic and operative parameters (Figure 7-6).

The results indicated that in univariate analysis, several factors were significantly associated with the odds of developing a leak after sleeve gastrectomy (Figure 7-6).³⁹ The use of conventional staplers (legacy Endo GIA™ and Duet single-height staples) was found to be associated with greater odds (2.4-fold greater, $p = 0.009$) of leak compared to Tri-Staple™ technology, on par with smoking status and use of antacids prior to surgery.³⁹ In contrast, demographic parameters such as age, sex, and weight were not significantly associated with leak risk.³⁹ These data are consistent with the suggestion of increased staple-line security determined by the leak pressure testing of Derici et al., 2018 on the excised stomach.³⁸

ⁿ American Society for Bariatric and Metabolic Surgery, data for 2014-2017 from <https://asmbs.org/resources/estimate-of-bariatric-surgery-numbers>. Published June 2018. Accessed Aug. 2019.

Figure 7-6 Conventional stapler use among risk factors for the development of leak after sleeve gastrectomy

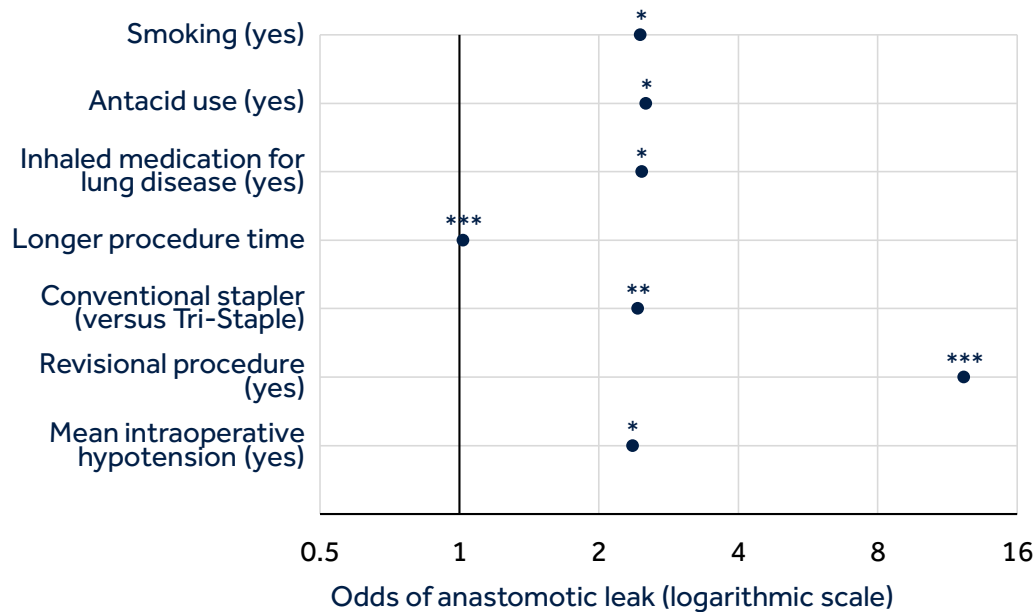

Data are shown from Nienhuijs et al., 2016 of a retrospective analysis of sleeve gastrectomy leak risk factors.³⁹ Note that although the effect of procedure time is small (odds ratio = 1.02), the effect was reported as highly significant ($p = 0.000$). *, $p < 0.05$; **, $p < 0.01$; ***, $p < 0.001$.

Complications such as leak or bleeding associated with the staple line are a major concern for surgeons, despite the overall low incidence of 1–6% for both.⁹⁷ When a complication occurs, the consequences can be “both clinically devastating for the patient and expensive for the facility.”⁹⁷ As previously described (section 3.6), reinforcement of the staple line is one method considered acceptable by many to reduce the risk of these complications.³⁶

A retrospective analysis of patient data investigated leaks and bleeding after sleeve gastrectomy.¹²⁵ All consecutive patients at a single institution who received sleeve gastrectomy were included in the analysis and were divided into two groups: those who received Tri-Staple™ technology without reinforcement ($n=187$) and those who received Tri-Staple™ technology with reinforced reload ($n=103$). No statistically significant differences were observed in patient demographics (age, sex ratio, baseline weight, baseline body mass index) between groups.

Results indicated an association of decreased complication incidence with use of Tri-Staple™ technology with reinforced reload compared to Tri-Staple™ technology alone (Figure 7-7).¹²⁵ Significantly less bleeding ($p=0.001$) was observed in the group managed with Tri-Staple™ technology with reinforced reload (22%, 23 of 103 patients) compared to Tri-Staple™ technology alone (42%, 78 of 187 patients), although all cases of bleeding were considered moderate and controlled with either sutures or clips.¹²⁵ The authors proposed that this reduction in bleeding contributed to the observed significant reduction in operative time (50.9 ± 17.1 minutes in the reinforced reload group versus 57.4 ± 16.4 minutes in the non-reinforced group, $p=0.006$). A non-significant reduction in the incidence of postoperative leak was also observed, with no cases in the group with reinforced reload use versus 1.1% (2 out of 187 operations) in the group without reinforcement. Both cases of leak required reoperation to correct.¹²⁵

Figure 7-7 Comparative analysis of complication incidence of complications after sleeve gastrectomy using Tri-Staple™ technology +/- reinforcement

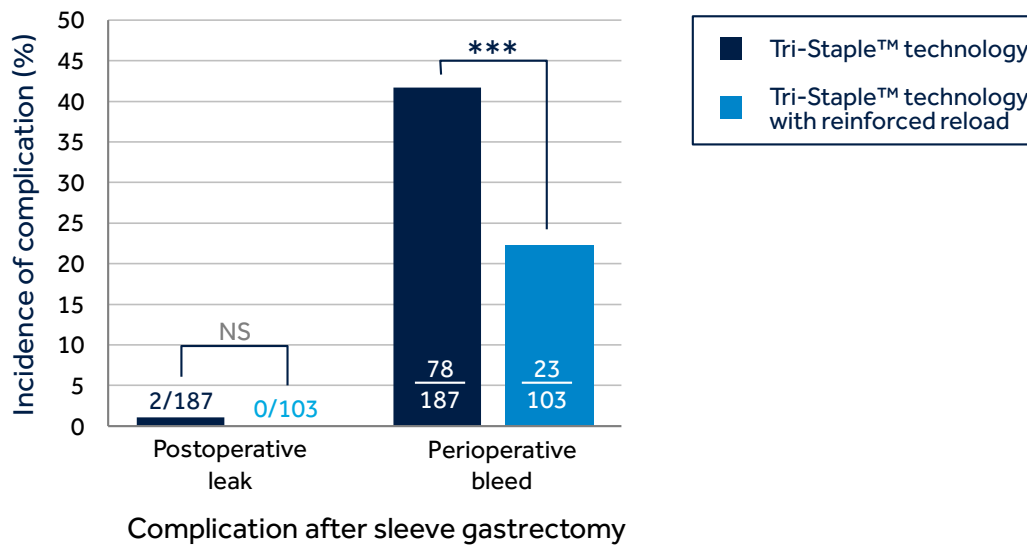

Data¹²⁵ are shown from the study of El Moussaoui et al., 2018. Incidence of leaks and bleeding after sleeve gastrectomy are shown. Values superimposed on the bars indicate the number of patients with the complication over the total number of patients in the corresponding treatment group. ***, $p \leq 0.001$

A randomized controlled trial evaluated the impact of preloaded reinforcement on Tri-Staple™ technology in sleeve gastrectomy patients.⁴⁰ Patients in both arms received Tri-Staple™ technology closure with the iDrive™ powered stapling system. The control arm was managed with bare Tri-Staple™ technology and oversewing of the staple line with absorbable barbed suture ($n=50$) while the intervention arm used Tri-Staple™ technology with reinforced reload ($n=50$).

In terms of operative parameters, the use of Tri-Staple™ technology with reinforced reload was associated with significantly shorter operating time compared to oversewing of the staple line (55.4 ± 9.4 min versus 66.1 ± 11.6 min, $p < 0.001$).⁴⁰ As mentioned above, leaks and bleeding post surgery are of concern, however in this study, there was a single leak in the suture group and no bleeding in either group. Postoperatively, the group managed using Tri-Staple™ technology with reinforced reload experienced a longer postoperative hospital stay (3.3 ± 1.4 days in the reinforced reload group versus 2.6 ± 1.2 days in the oversewn group, $p = 0.05$).⁴⁰

The primary outcome of the study was occurrence of postoperative nausea and vomiting (PONV). The occurrence of PONV after bariatric surgery is not a minor inconvenience to patients, since it can result in considerably greater resource utilization after discharge in comparison to cases where it doesn't occur (see section 4.3.3.1).¹⁰⁰ In this study, the use of Tri-Staple™ technology with reinforced reload was associated with significantly reduced PONV compared to oversewing (Figure 7-8).⁴⁰ The authors proposed that surgical technique (fold in the stomach during suturing) or the increased operative time (leading to increased anesthesia time) may have contributed to the greater impact of PONV in the oversewn group in comparison to the reinforced reload group.⁴⁰

REDUCED COMPLICATIONS WITH REINFORCED TR

NAUSEA AND VOMITING AFTER SLEEVE GASTRECTO

Ruiz-Tovar 2018, Spain, randomized controlled trial

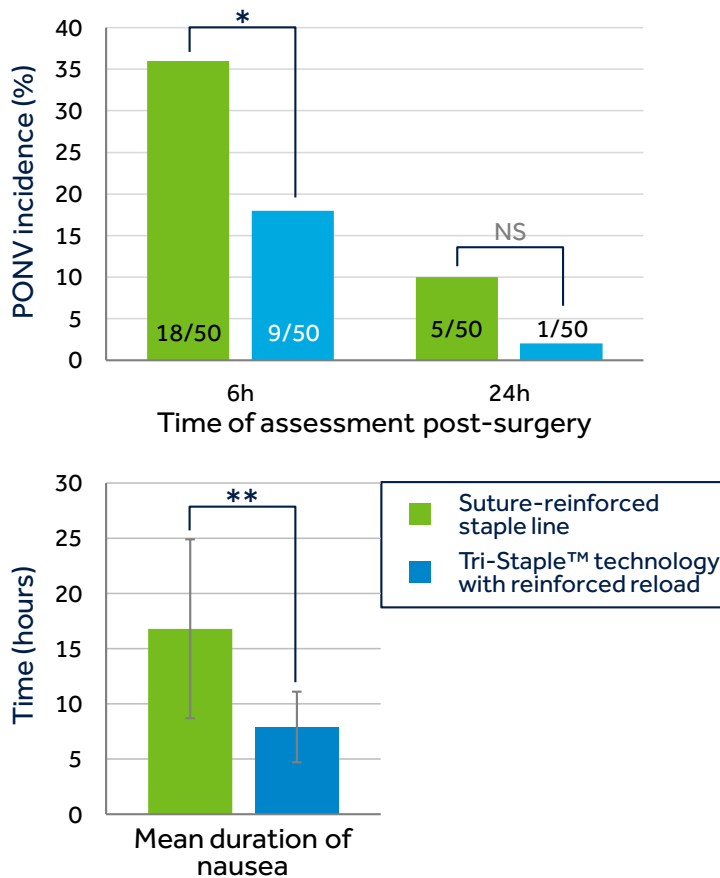

Data are shown from Ruiz-Tovar et al., 2018 regarding postoperative complications according to closure during sleeve gastrectomy.⁴⁰ PONV, postoperative nausea and vomiting; * $p < 0.05$; ** $p < 0.01$.

7.4.2. Gastrectomy

Surgery to excise affected tissue is an option for both early- and late-stage gastric cancer.¹²¹ Removal of a portion of the gastric tract requires closure of the remaining tissue or creation of new anastomoses or both, depending on the location of disease and the amount of tissue removed.

In a study of distal gastrectomy, the use of Tri-Staple™ technology was compared to Ethicon Endopath™* single-height staples in a prospective, single-institution study.⁴³ A prospective cohort of patients managed with Tri-Staple™ technology (n=23) for removal of the stomach was compared with matched historical controls treated with Endopath™* devices (n=19). Primary outcomes were “short-term surgical outcomes related to anastomosis including anastomotic leakage, stenosis, bleeding, and stasis.”⁴³

Figure 7-9 Tri-Staple™ technology versus Endopath™* in distal gastrectomy

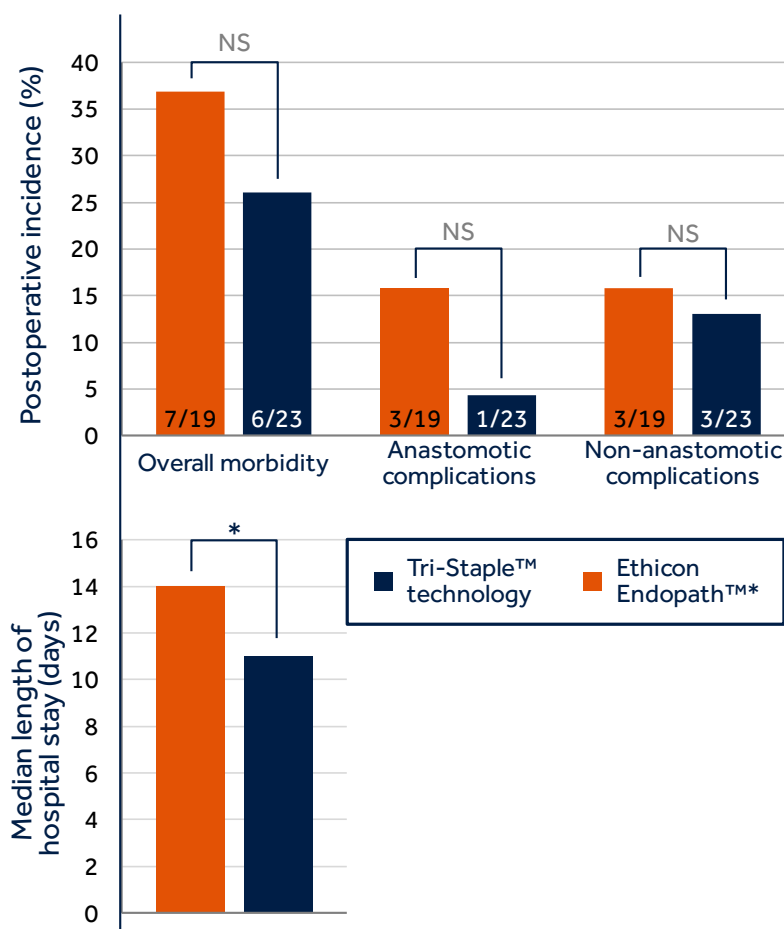

Data are shown for the study⁴³ of Man-I et al., 2015 for laparoscopic distal gastrectomy patients treated with Tri-Staple™ technology versus matched historical Ethicon Endopath™* controls. Values shown on the bars indicate the number of patients with the complication over the total number in the corresponding treatment group. Anastomotic complications were stasis, anastomotic leakage, anastomotic stenosis, and anastomotic bleeding. Non-anastomotic complications were pancreatic fistula, false aneurysm, and liver infarction. Values for length of hospital stay are medians. NS, non-significant; * $p < 0.05$.

Complications between the two treatment groups were non-significantly lower for patients managed with Tri-Staple™ technology than for Endopath™* in terms of overall morbidity, anastomosis-related, and non-anastomosis-related complications (Figure 7-9).⁴³ Among

the anastomosis-related complications, none were related to leakage in either group, nor were there any cases of bleeding or stenosis in either group.⁴³ Regarding bleeding, however, the data reported significantly lower intraoperative blood loss in the Tri-Staple™ technology group compared to the Endopath™*-managed group (median 15 mL in the Tri-Staple™ technology group versus 37 mL in the Endopath™* group, $p = 0.02$). Significantly shorter median hospital length of stay was recorded for the Tri-Staple™ technology patients, consistent with the (non-significant) trend towards lower rates of complications compared to patients who had been managed with Ethicon Endopath™* staples.⁴³

The addition of reinforcement to Tri-Staple™ technology has also been investigated in the context of gastrointestinal resection for cancer.⁴⁴ In this retrospective analysis, patients underwent laparoscopic distal gastrectomy to create a delta-shaped anastomosis with Tri-Staple™ technology; one arm with preloaded absorbable membrane buttressing (Tri-Staple™ technology with reinforced reload, $n=40$) and the other treatment arm with Tri-Staple™ staples only ($n=90$).⁴⁴

Outcomes for postoperative complications and length of stay are shown in Figure 7-10. There was a significant decrease in the incidence of bleeding requiring intervention for patients in the Tri-Staple™ technology with reinforced reload group compared to the non-reinforced group (12% versus 0%, non-reinforced versus reinforced respectively, $p = 0.02$). Other complications demonstrated no significant difference; however, many demonstrated a trend towards decreased complication incidence in the Tri-Staple™ technology with reinforced reload group compared to the non-reinforced group.⁴⁴ The low complication rates for Tri-Staple™ technology alone are consistent with distal gastrectomy results⁴³ reported by Man-I et al., 2015. Similarly, operative time followed a comparable trend. In the Man-I et al., 2015 study, Tri-Staple™ technology alone was associated with non-significantly shorter operative time than Endopath™* (median 278 versus 319 minutes, $p = 0.056$).⁴³ In the Nagahisa et al. report, Tri-Staple™ technology alone had a median operating time of 264 minutes while the group with reinforced reload had a median operative time of 248 minutes.⁴⁴ Only one anastomotic leakage occurred in the non-reinforced group, and no cases of anastomotic bleeding occurred in either group.

The results from these studies of stapling in gastrectomy suggest similar trends of decreasing complications associated with the use of Tri-Staple™ technology: Tri-Staple™ technology alone compared to single-height Ethicon Endopath™* staples⁴³ and Tri-Staple™ technology with reinforced reload compared to Tri-Staple™ technology without reinforcement.⁴⁴ Bleeding-related outcomes showed significant decreases in terms of intraoperative blood loss⁴³ and incidence of bleeding requiring reintervention⁴⁴ in relation to corresponding comparators. Overall morbidity, anastomosis-related complications, and hospital length of stay demonstrated a trend (non-significant) towards decreases with Tri-Staple™ technology compared to the Endopath™* cohort. Using Tri-Staple™ technology with reinforced reload trends towards additional improvement in these outcomes versus non-reinforced Tri-Staple™ technology. Taken together the results indicate the potential for an increasingly beneficial trend in patient outcomes and hospital resource usage, but results should be confirmed in a concurrent (non-historical) randomized trial with more participants.

Figure 7-10 Tri-Staple™ technology with reinforced reload: complications after distal gastrectomy

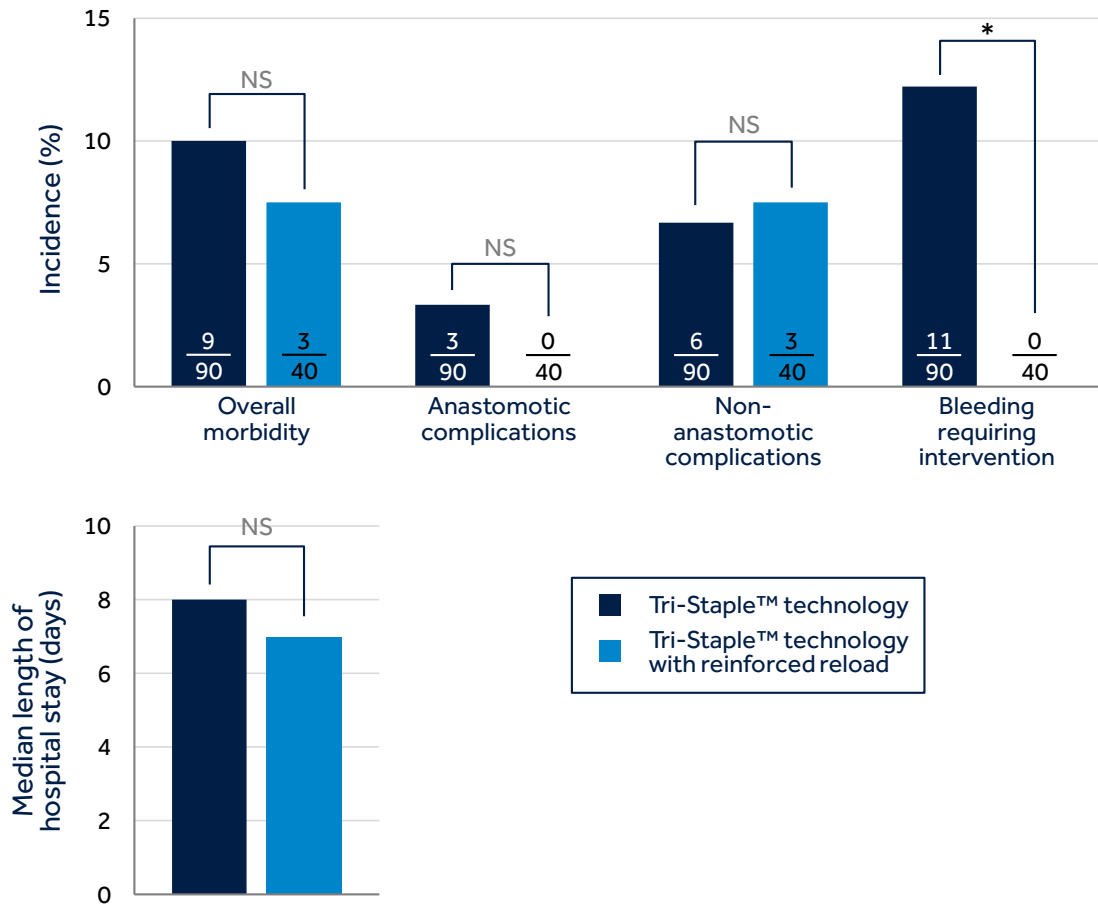

Data⁴⁴ are shown from Nagahisa et al., 2015 for comparison of postoperative complications occurring after laparoscopic distal gastrectomy in patients managed with Tri-Staple™ technology only, or with reinforced reload. Anastomotic complications were abscess formation around the anastomosis, anastomotic leakage, anastomotic bleeding, stenosis, and stasis. Non-anastomotic-related complications were pancreatic-related complications, abscess formation, postoperative bleeding, pneumonia, port site hernia, and cerebral infarction. Values shown on the bars indicate the number of patients with the complication over the total number in the corresponding treatment group. NS, non-significant.

7.5. Colorectal resection

Modifications can occur farther along the gastrointestinal tract, and these can include, for example, colonic resection. To maintain a degree of normal gastrointestinal function, anastomoses are required to reconnect the lumen of the tract on either side of the resected tissue. Fewer studies were identified of the use of Tri-Staple™ technology in colorectal resection compared to other surgical procedures (sections 7.3, 7.4, 7.6.1), and these were not comparative of Tri-Staple™ technology versus single-height stapling. Instead, these were single arm studies of the use of Tri-Staple™ technology with reinforced reload,¹⁸ and Tri-Staple™ technology with radial reloads (sometimes referenced in the literature as a “curved” stapler cartridge).⁴⁵

7.5.1. Tri-Staple™ technology with reinforced reload

A single-arm study from Japan reported outcomes using Tri-Staple™ technology with reinforced reload in patients undergoing resection at differing levels of the distal colon (n=62 patients, Table 7-1).¹⁸ The 12 reported complications occurred in 11 patients and included ileus (4.8%), bleeding (1.6%), and one case of anastomotic leakage (1.6%). The authors noted that the latter outcome, anastomotic leakage, was considerably lower than the anastomotic leakage rate reported in a prospective, multicenter study also in Japan in which the anastomotic leakage rate was 8.4% across 395 patients.^{18,126} In the multicenter Japanese study, among operative leakage risk factors investigated, the authors made note that other investigators have identified multiple stapler firings (more than 2) as an independent risk for increased anastomotic leak. In their report, however, only a trend towards increased risk was determined.¹²⁶

Table 7-1 Parameters and outcomes from single arm laparoscopic colorectal resection with Tri-Staple™ technology with reinforced reload

Parameter	Outcome
Patients (N)	62
Tumor location	17 rectosigmoid 34 upper rectum 11 lower rectum
Stapler firings (n/N, %)	One: 32 (51.6%) Two: 28 (45.2%) Three: 2 (3.2%)
Operative time (min)	253 (152-510) [median (range)]
Conversions to open (n/N, %)	0/62 (0%)
Patients with complications (n/N, %)	11/62 (17.7%)
Anastomotic leakage (n/N, %)	1/62 (1.6%)
Length of hospital stay (days, median [range])	11 [8-59]

Single-arm outcomes for patients undergoing laparoscopic colon resection using Tri-Staple™ technology with reinforced reload.¹⁸

7.5.2. Tri-Staple™ technology with radial reload

Among surgical interventions for colorectal resection, operations on the lower anterior section (involving the rectum) present technical challenges. This section of the colon is located deep within the pelvis and access using conventional linear staplers may be impeded by the anatomy of the pelvic bone (Figure 7-11).⁴⁵ Since the linear, articulated stapler consists of two straight segments with a hinge between them, there is restricted range for achieving angles to easily close the necessary bowel structure. Preclinical investigations on human cadavers suggested that the Tri-Staple™ technology radial reload may facilitate the required access.⁵ A single arm study (n = 27 patients) in Japan sought to investigate this hypothesis in human patients undergoing lower anterior resection (Figure 7-11).⁴⁵ Although the data do not provide comparisons with previous results achieved at the reporting institution, the preliminary results indicated positive outcomes with all procedures completed successfully, no intraoperative complications and a low rate (11%) of postoperative complications; of these, 0% were anastomotic leak.⁴⁵

Figure 7-11 Single-arm evaluation of Tri-Staple™ technology with radial reload for low anterior resection

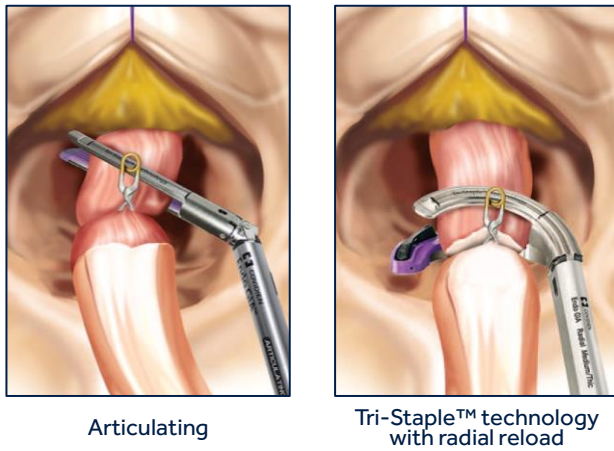

Parameter	Outcome
Patients	27
Tumor location	17 sigmoid 10 rectosigmoid
Stapler firings for distal bowel (n/N, %)	One: 26 (96.3%) Two: 1 (3.7%)
Operative time (min)	152 (97 – 304)
Intraoperative complications (n/N, %)	0/27 (0%)
Postoperative complications (n/N, %)	3/27 (11%)
Anastomotic leakage (n/N, %)	0/24 (0%)
Length of hospital stay (days, median [range])	6 [4-17]

Images⁴⁵ copyright Watanabe et al., 2016 and the American Society of Colon and Rectal Surgeons, Inc. Authors note the anatomical challenge presented by the location of the resection to stapling with an articulated stapler. A stapler with a curved cartridge (Tri-Staple™ technology with radial reload) was deemed to provide better access. Operative and postoperative outcomes are shown for the single-arm study using Tri-Staple™ technology with radial reloads.

Another report surveyed colorectal surgeons worldwide to obtain a broader sense of surgeons' experience with Tri-Staple™ technology with radial reload.³⁵ Thirty-five respondents who performed 114 procedures using Tri-Staple™ technology with radial reloads completed a questionnaire regarding clinical appropriateness of the technology as well as assessment of its performance on its own and in comparison to devices and technology currently in use at their institutions. Responses were filtered to exclude those who used radial reloads in non-rectal procedures (29 of 114 that included sigmoidectomies, and left, right, and total colectomies). After exclusion, 31 surgeons assessing the performance of Tri-Staple™ technology with radial reloads in 85 procedures remained.³⁵

Surgeons reported a high degree of clinical applicability in procedures where Tri-Staple™ technology with radial reload was used (93%).³⁵ Radial reload use was indicated to be the preferred technology in a large proportion of procedures according to various functional capabilities (all proportions over 80%) in comparison to the current technology in use at the surgeons' respective institutions (Table 7-2). Functionality factors included better visibility, maneuverability, lower pelvis access, and distal resection margin (Figure 7-12).³⁵

Table 7-2 Devices usually used in rectal resections by surgeon respondents assessing Tri-Staple™ technology with radial reloads

Device (Current manufacturer)	Count (%)
TA™ Stapler (Medtronic)	43 (39%)
Endo GIA™ Universal (Medtronic)	31 (28%)
Contour™* Curved cutter (Ethicon)	26 (23%)
Echelon™* (Ethicon)	3 (3%)
Other (Not specified)	8 (7%)

Counts are as reported for the entire respondent cohort of 35 surgeons assessing 114 procedures; however, the above total of 111 suggests 3 respondents did not specify. Results ordered in decreasing frequency.

Figure 7-12 Surgeon survey assessing performance of Tri-Staple™ technology with radial reloads

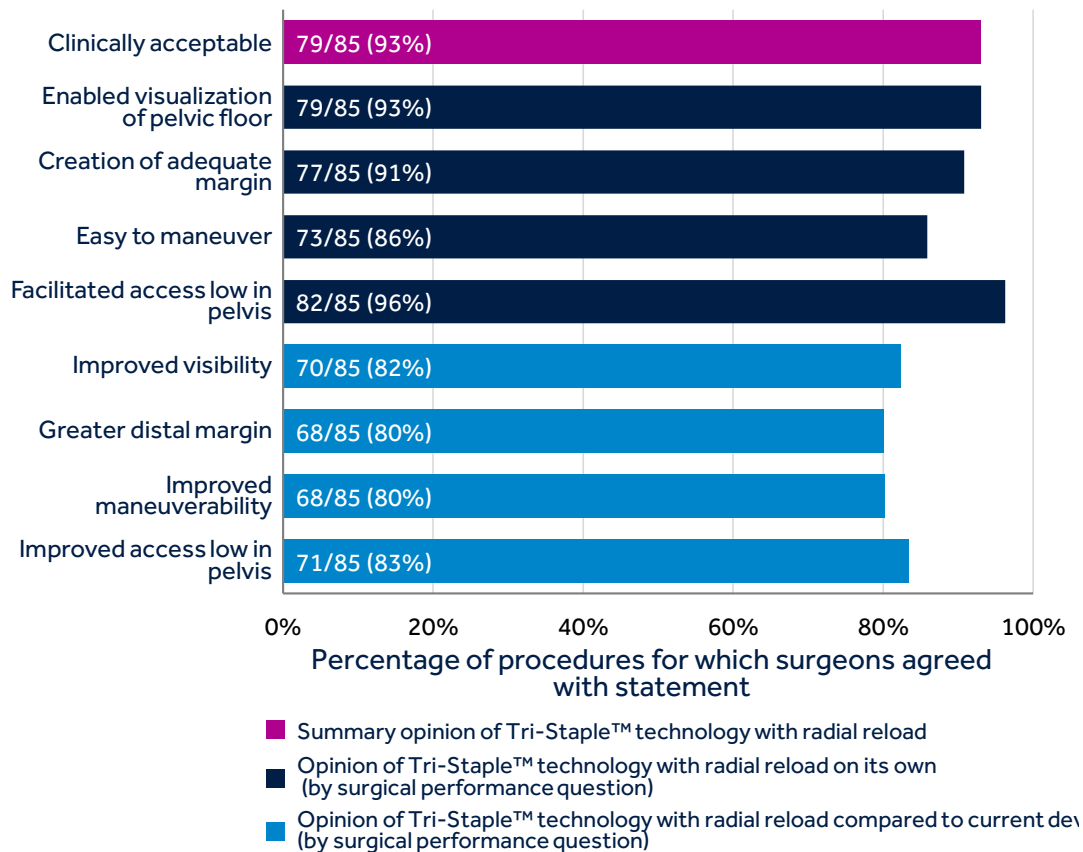

Survey results are shown from the study³⁵ of van Vugt et al., 2015 of 31 surgeons globally recruited who were reported as “strongly agreeing” or “agreeing” to the indicated statements regarding use of Tri-Staple™ technology with radial reloads in patients. Results were presented as percentage of procedures (n=85), but the number of surgeons for each statement was not reported.

7.6. Other surgical areas

7.6.1. Pancreatic

Surgical treatment of pancreatic tissue can take a variety of forms, depending on the extent and location of disease. These procedures can include distal pancreatectomy, total pancreatectomy, and pancreaticoduodenectomy.^{127,128}

In conjunction with surgeries on the pancreas or adjacent tissues, there is a risk of developing postoperative pancreatic fistula (POPF) as a complication. According to international guidelines, classes of POPF are graded according to severity (see section 4.3.3.2).^{19,103} Grade A is asymptomatic and may close spontaneously or with conservative treatment. Grade B fistula requires drainage of abdominal fluid or abscess leading to hospital readmission, or inability to proceed to normal diet within 10 days of surgery. Grade C is associated with reoperation or death. Clinically-relevant POPF (CR-POPF) is thus defined as grades B and C, both of which may greatly delay recovery and pose a significant healthcare burden.¹⁹ Risk factors for the development of CR-POPF have been the subject of several studies.^{47,49-51,64,65,104,129} Definitions of CR-POPF are not always consistent throughout the literature; the present analysis uses the definitions as reported in the referenced studies.

Figure 7-13 Sample reports of postoperative pancreatic fistula after distal pancreatectomy

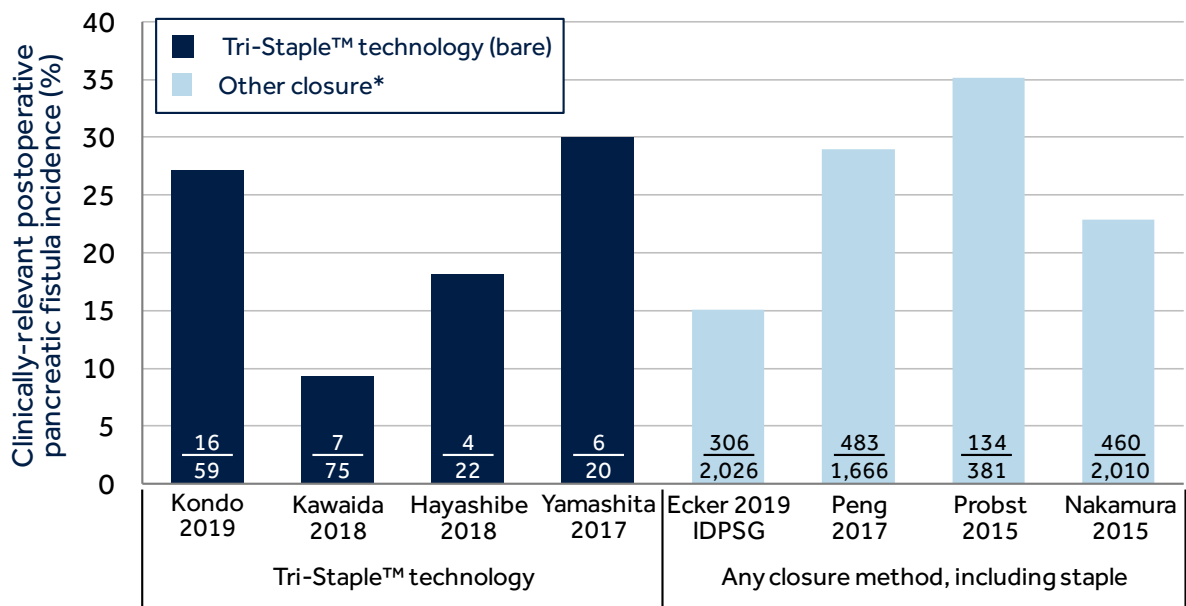

Source

Data are shown for rates of clinically-relevant (CR-) postoperative pancreatic fistula (POPF) after distal pancreatectomy (DP) for observational reports of Tri-Staple™ technology.^{46,49-51} For comparison, examples of other studies that examined CR-POPF after DP include a large international observational multicenter study²⁰ and meta-analyses.^{65,66} A multicenter study from Japan, the same country where the Tri-Staple™ technology studies were conducted is also included.⁶⁴ Studies shown are: Kondo 2019,⁵⁰ Kawaida 2018,⁴⁹ Hayashibe 2018,⁴⁶ Yamashita 2017,⁵¹ Ecker 2019,²⁰ Peng 2017,⁶⁵ Probst 2015,⁶⁶ and Nakamura 2015.⁶⁴ *Other closure methods include studies where the specific method was not reported or referenced bare staples only; studies and study arms where reinforcement was referenced were excluded. IDPSG, International Distal Pancreatectomy Study Group.

In the literature searches conducted for the present document, no study was identified that performed a direct comparison between Tri-Staple™ technology and single-height staples for the risk of CR-POPF. Rates have been reported in a single arm study⁴⁹ and in a study that compared Tri-Staple™ technology with reinforced reload with other methods of pancreatic stump closure.⁴⁷ To provide context for these POPF rates, a non-comprehensive survey of medical literature revealed reports of POPF after distal pancreatectomy from international meta-analyses, multicenter and single center studies. Inference testing of significance would not be reliable in the absence of a full systematic evaluation of all available reports of POPF (including case series, which were not included for data analysis in the present work); however, plotting of the results provides an indication of results that have been obtained using Tri-Staple™ technologies in the context of CR-POPF rates across various closure types and surgical approaches (Figure 7-13).^{20,46,49,64-66} Note that some of these other studies may include Tri-Staple™ technology, as specific methods of closure or stapling were not reported in all studies. Studies or study arms were, however, excluded from this analysis where the closure referenced use of staple reinforcement.

To aid in the creation of a secure staple line, reinforcement of the staple line in pancreatic surgeries has been investigated.^{46,47,51} As with non-reinforced staples, the main outcome of interest was the incidence of CR-POPF, and the rate of CR-POPF can be viewed in the context of other studies or study arms where Tri-Staple™ technology with reinforced reload is not specifically used. Some studies performed comparisons between the reinforced and non-reinforced Tri-Staple™ technology, allowing the rates from study arms to be separated (Figure 7-14). Otherwise, the Tri-Staple™ technology with reinforced reload rates of CR-POPF can also be viewed in the context of rates determined in other studies of distal pancreatectomy where closure methods were unspecified^{20,65} or in a study arm where bare, non-Tri-Staple™ technology staples were used (Figure 7-14).⁶⁶ In studies comparative between arms treated with Tri-Staple™ technology with and without reinforcement, statistical analysis revealed decreases in the rate of CR-POPF (significant^{46,51} and non-significant⁵⁰) when reinforcement was used. The latter study of Kondo et al., 2019, when stratifying outcomes for pancreatic stump thickness < 14 mm, found the reduction in CR-POPF rate to be significantly lower with reinforced reload compared to non-reinforced Tri-Staple™ technology ($p = 0.01$).⁵⁰

Pooled rates of CR-POPF indicate a trend of decreased incidence associated with Tri-Staple™ technology with or without reinforced reload in relation to corresponding comparators (Figure 7-15). From the collected data, the pooled incidence of CR-POPF with Tri-Staple™ technology^{46,49} trends to lower levels compared to other closure methods (other staple, suture, or unspecified).^{20,64-66} Use of Tri-Staple™ technology with reinforced reload^{46-48,50,51} trends to lower rates of CR-POPF in comparison to non-reinforced staples or other closure methods.^{46,50,51} Together, these data indicate a trend in decreasing incidence of CR-POPF from other closure technologies, to Tri-Staple™ technology. to the lowest rates observed for Tri-Staple™ technology with reinforced reload. Note that the present analysis of comparative CR-POPF rates focused on studies of the highest quality identified among the present search results (meta-analyses, large multicenter studies); however, it did not comprise a systematic review of the literature to independently identify all potentially-relevant literature. Claims regarding trends must therefore be taken only in the context of the present dossier.

Figure 7-14 Sample reports of clinically-relevant postoperative pancreatic fistula after distal pancreatectomy with reinforced staples

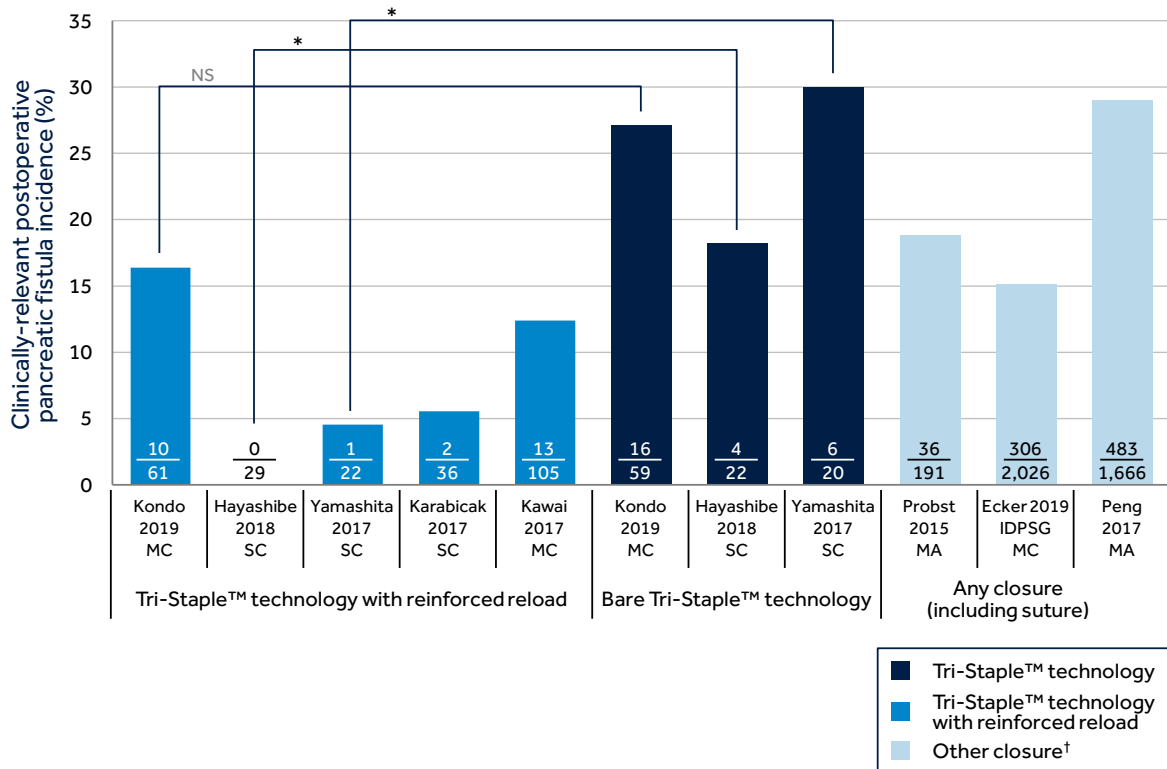

The rates of clinically-relevant postoperative pancreatic fistula (CR-POPF) are shown for various studies reporting the outcome in relation to pancreatic stump closure during distal pancreatectomy. The groups consisted of studies or study arms with Tri-Staple™ technology with reinforced reload,^{46-48,50,51} study arms with bare Tri-Staple™ technology,^{46,50,51} and studies with other or non-specified closure methods^{20,65,66} In cases where both Tri-Staple™ technology with reinforced reload and bare Tri-Staple™ technology were used, the significance level reported by the study is shown (Kondo 2019,⁵⁰ Hayashibe 2018,⁴⁶ Yamashita 2017,⁵¹). Studies shown are: Kondo 2019,⁵⁰ Hayashibe 2018,⁴⁶ Yamashita 2017,⁵¹ Karabacak 2017,⁴⁷ Kawai 2017,⁴⁸ Probst 2015,⁶⁶ Ecker 2019,²⁰ and Peng 2017.⁶⁵ †Other comparators in the context of reinforced reloads included studies that referenced non-specified reinforcement methods, and those that separated reinforced and non-reinforced staple arms. * p < 0.05; MA, meta-analysis; MC, multicenter; NS, non-significant; SC, single-center.

Figure 7-15 Summary of distal pancreatectomy outcomes comparing Tri-Staple™ +/- reinforcement to other closure methods

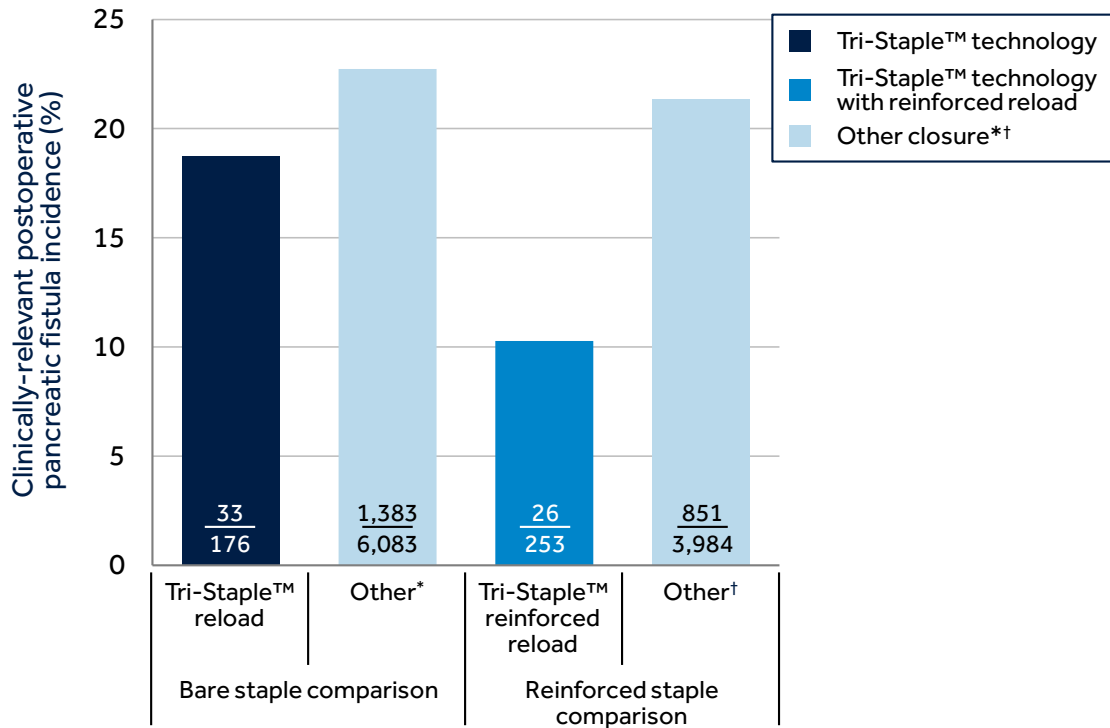

Summary of pooled rates of clinically-relevant postoperative pancreatic fistula after distal pancreatectomy aggregated from Figure 7-13 and Figure 7-14. The bare staple comparison consists of studies with Tri-Staple™ technology only^{46,49-51} and corresponding studies with various closure methods.^{20,64-66} The reinforced staple comparison consists of studies or study arms in which Tri-Staple™ technology with reinforced reload were used^{46-48,50,51} and corresponding studies or arms that consisted of unspecified, mixed, or non-reinforced closure methods.^{20,46,50,51,65,66} *Other closure methods include studies where the specific method was not reported or referenced bare staples only; studies or arms where reinforcement was referenced were excluded. †Other comparators in the context of reinforced reloads included studies that referenced non-specified reinforcement methods, and those that separated reinforced and non-reinforced staple arms. * p < 0.05; *** p < 0.001.

7.6.2. Hepatic

A comparative study of the use of Tri-Staple™ reloads in laparoscopic liver resection presented a comparison of a cohort of patients managed with Tri-Staple™ technology to historical controls.²² The institution in Belgium instituted the use of Tri-Staple™ technology as standard of care in 2011 and compared operative outcomes to patients treated before this time; the details of the surgical procedure and closure methods were not specified.²² Although the operative procedure was described, the protocol of the study did not indicate what stages of the historical method were replaced with Tri-Staple™ technology. The authors used the staplers to divide the major intrahepatic vessels and the liver parenchyma in select patients.

Figure 7-16 Tri-Staple™ technology versus non-stapled laparoscopic liver resection

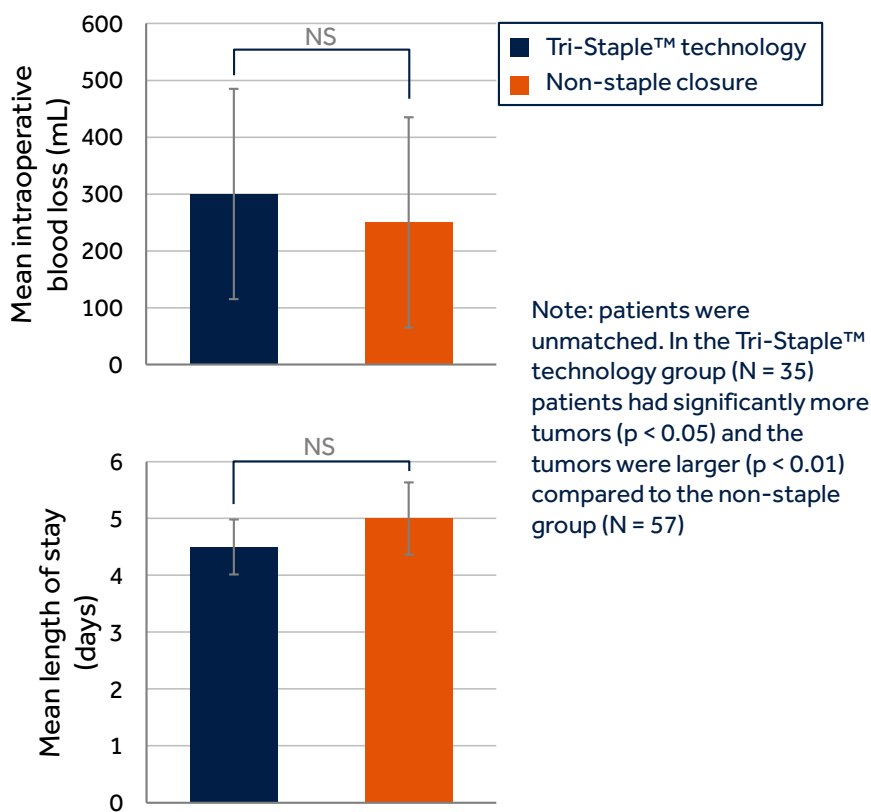

Data are shown from the retrospective study of Scuderi et al., 2014 for the outcomes of intraoperative blood loss and length of stay for a patients undergoing laparoscopic liver resection with and without Tri-Staple™ technology.²² Note that while the operative procedure is described, the protocol does not indicate what procedures in the control, non-stapled group were replaced with Tri-Staple™ technology. Data for length of stay were presented as medians and ranges, while data for bleeding were presented as means and ranges. These data were used to estimate mean and standard deviation according to the method¹⁰⁵ of Wan et al., 2014 for consistency. Plots shown above indicate means and 95% confidence intervals about the mean. NS, non-significant.

The results indicated a non-significant trend towards lower mean length of hospital stay and equivalent intraoperative blood loss (Figure 7-16).²² Since the patients were not propensity-score matched on any demographic or outcome variables, other differences were observed between the groups that may have influenced operative outcomes. Notably, the modern group treated with Tri-Staple™ technology had significantly more tumors ($p < 0.05$), and the average tumor size was larger ($p < 0.01$) than for patients in the non-stapled control group. The authors also noted that significantly more patients underwent major hepatectomy surgery in the Tri-Staple™ technology group compared to the control (10/35 versus 0/57, $p = 0.0001$).

From this study, use of Tri-Staple™ technology in liver resection to secure major hepatic vessels and to divide liver parenchyma is at minimum statistically equivalent to conventional non-stapled methods of liver surgery.²² It should be noted, however, that this comparability resulted despite the fact that patients in the stapler treatment had more severe disease and some received major liver surgery compared to the control group with less severe disease and no major liver surgeries. This difference in characteristics between the treatment groups may suggest benefits of Tri-Staple™ technology compared to the control that were obscured and may be observed in matched patient groups of comparable degree of disease, but a clinical investigation testing this hypothesis has not been identified. The study authors noted that the introduction of Tri-Staple™ technology “influenced significantly the indications allowing for major hepatectomy, 2-stage hepatectomy and living donor resections, which otherwise would be extremely difficult or unsafe to perform.”²²

CHAPTER 8

POWERED STAPLING SYSTEMS



The Signia™ Stapling System

- Biomechanical benefits of powered stapling
- Powered versus manual stapling in clinical application
- iDrive™ powered stapling system in clinical application
- The Signia™ stapling system
 - Signia™ stapling system technology
 - Adjusting firing speed
 - Device usability
 - Signia™ stapling system in clinical application

8. Powered stapling systems

8.1. Summary and key messages

- **Significantly less hand force required to operate:** Maximum pressures experienced by the hand operating the stapler are significantly lower for powered compared to manual staplers.^{130,†}
- **Firing technique can influence stapler performance:** Preclinical studies have shown that for complex tissues of varying thickness, duration of tissue clamping and speed of firing can influence rates of proper staple formation.^{3,69,‡}
- **Significantly lower complication rates:** Powered devices in pulmonary⁶⁷ and bariatric⁶⁸ procedures have been associated with significantly lower bleeding/transfusion rates among patients compared to manual devices.^{67,68}
- **Improved hemostasis in bariatric procedures:** The iDrive™ stapling system was associated with less need to use clips for hemostasis during sleeve gastrectomy compared to the Ethicon Echelon™* stapler.⁸
- **Powered stapling provides performance consistency:** Suggestions for improving stapling outcomes, such as by increasing compression time or slowing rate of firing, are subjectively implemented in manual systems and must be moderated by the operating surgeon.^{47,49} Powered systems provide consistency in less surgeon-to-surgeon variability.^{130,†}
- **Highly rated usability:** The Signia™ stapling system was rated highly for performing stapling functions one-handed (100%) and providing useful force feedback (97%) in internal testing of simulated surgeries in porcine models among surgeons (n=38) from bariatric, colorectal, thoracic, and general surgery disciplines.^{o,‡}
- **High acceptability of Signia™ stapling system was not biased by usual device:** The population of nurses (n=50) and surgeons (n=38) who participated in internal testing and rated the Signia™ stapling system highly for applicability and function (97%–100%) consisted of participants with experience of both Medtronic and Ethicon staplers (4% of nurses and 24% of surgeons), and those who typically use Ethicon staplers only (50% of nurses and 14% of surgeons).^{o,‡}

[†]Benchtop test results may not correlate with clinical performance in humans; [‡]Preclinical results may not correlate with clinical performance in humans.

8.2. Surgical stapling revisited

Tri-Staple™ technology incorporates multiple features designed to improve surgical stapling performance and patient outcomes across a range of surgical applications (see chapters 5 and 6). Clinical application of the technology (alone or as reinforced reload) has demonstrated equivalent to improved patient outcomes in thoracic, bariatric, and colorectal

^o Internal study, RE00024826, rev D. Summative usability report, Signia™ stapling system. Testing was performed with multiple cohorts of individual surgeons and paired surgical teams consisting of a surgeon and surgical technician or registered nurse. Participants were recruited via a third party and were paid honoraria by Medtronic plc. Surgery simulated in porcine models during which surgeons completed approximately 281 staple fires of 95 Endo GIA Tri-Staple™ reloads, 91 Tri-Staple™ 2.0 reloads, and 105 Tri-Staple™ 2.0 cartridges.

surgeries compared to single-height staple technology or to non-reinforced staples, respectively (chapter 7). Beyond design improvements to the staples, an additional consideration in the quest to improve stapler performance and patient outcomes is how the staples are deployed.^{3,47,49,67,68}

Studies have demonstrated that the duration of the compression phase during which tissue is clamped and the subsequent speed of stapler firing can have a significant influence on the rate of proper staple formation, a requirement to the formation of an adequate seal in the tissue.^{3,69} Accordingly, surgical procedures in patients have been proposed in which both the time during which the tissue is compressed and the time to fire the staples have been increased to promote better stapler function in the thick tissue of the pancreas transected during distal pancreatectomy.^{47,49} Manual firing of a device, however, is highly dependent on the user. The speed at which the device is fired can result in inconsistencies in forces at the distal tip, potentially leading to tissue trauma.¹³⁰

Improvements to stapling technique can only be achieved by including the operator of the device, namely the surgeon, among design and deployment considerations. With manually-operated staplers, for example, the device must be ergonomically designed to allow comfortable handling by the surgeon, and be amenable to the force that can be generated with one hand.¹³¹ The fixed design and lever mechanisms inherent to manual stapler operation can result in variability in hand to device fit that may lead to challenges for operators.¹³¹

With these factors in mind, recent developments in stapler technology have sought to address issues of appropriate firing speed and the triggering of stapler firing. Powered staplers, in contrast to manual, are operated with push buttons rather than the manipulation of levers. The first example was the iDrive™ powered stapler.⁹ In powered stapling, technology developments have sought to address issues of regulating the surgical stapling process from clamping to final release of tissue. The subsequent advance from Medtronic plc in this area is the Signia™ stapling system. With this device, firing speed can be adapted in real time via the Adaptive Firing™ algorithm and when paired with Tri-Staple™ 2.0 technology, additional feedback regarding tissue property sensing can be provided to the user. Together, these components allow dynamic adjustment to firing properties in response to local tissue conditions.

This chapter focuses on aspects of powered stapling as they relate to the iDrive™ and Signia™ powered stapling systems, along with general aspects of powered stapling whether alone in observational evaluations of performance or in comparison to manual stapling devices. The results include, where appropriate, data from competing devices where suitable powered versus manual comparisons have been reported.

8.3. Biomechanical benefits of powered stapling

Biomechanical investigations have been performed to compare the impact in practice of using the powered iDrive™ stapling system compared to a manual stapler (Ethicon Echelon Flex™* 60) in an internal report.¹³⁰ Ten surgeons operated each device in an experimental setting. Data were obtained by placing sensors on the device to measure the degree of movement of the stapler tip during firing and the forces required to operate the two types of stapling device. Participants also rated their experience of using the device on a visual analog scale from 0 ("very bad") to 10 ("very good").¹³⁰

The results indicate significantly greater stability with the iDrive™ powered stapling system compared to the manual device, as illustrated by the smaller total distance traveled by the stapler tip during firing (Figure 8-1). This reduction in tip movement holds true whether the

operation of the stapler is performed in a neutral position (arm level at side) or in an “awkward” firing position, where the arm is raised and the wrist is angled downwards, as may occur to allow proper access through a trocar during a laparoscopic procedure.¹³⁰ This greater precision is achieved with considerably less force exerted on the hand of the surgeon during firing (Figure 8-2). Considering the possibility of multiple stapler firings over many procedures that a surgeon may perform per year, the powered device would thereby reduce the risk of fatigue or strain during operative procedures.¹³⁰ At the same time, reduced force during operation may also reduce the potential impact of surgeon hand dimensions or grip strength on the ability to perform precise maneuvers during procedures.¹³¹

When participant surgeons (n=10) were queried regarding impressions regarding use of the iDrive™ powered stapler versus the manual Ethicon Echelon Flex™* 60 stapler over six assessments of functionality on a visual analog scale from 0 (very bad) to 10 (very good), the mean scores for effort to fire and ease of use were significantly higher for the powered versus the manual stapler.¹³⁰ Most of the other measures trended towards higher scores for the powered versus the manual stapler (Figure 8-3).

Figure 8-1 Tip displacement during firing with iDrive™ powered stapler versus manual stapler

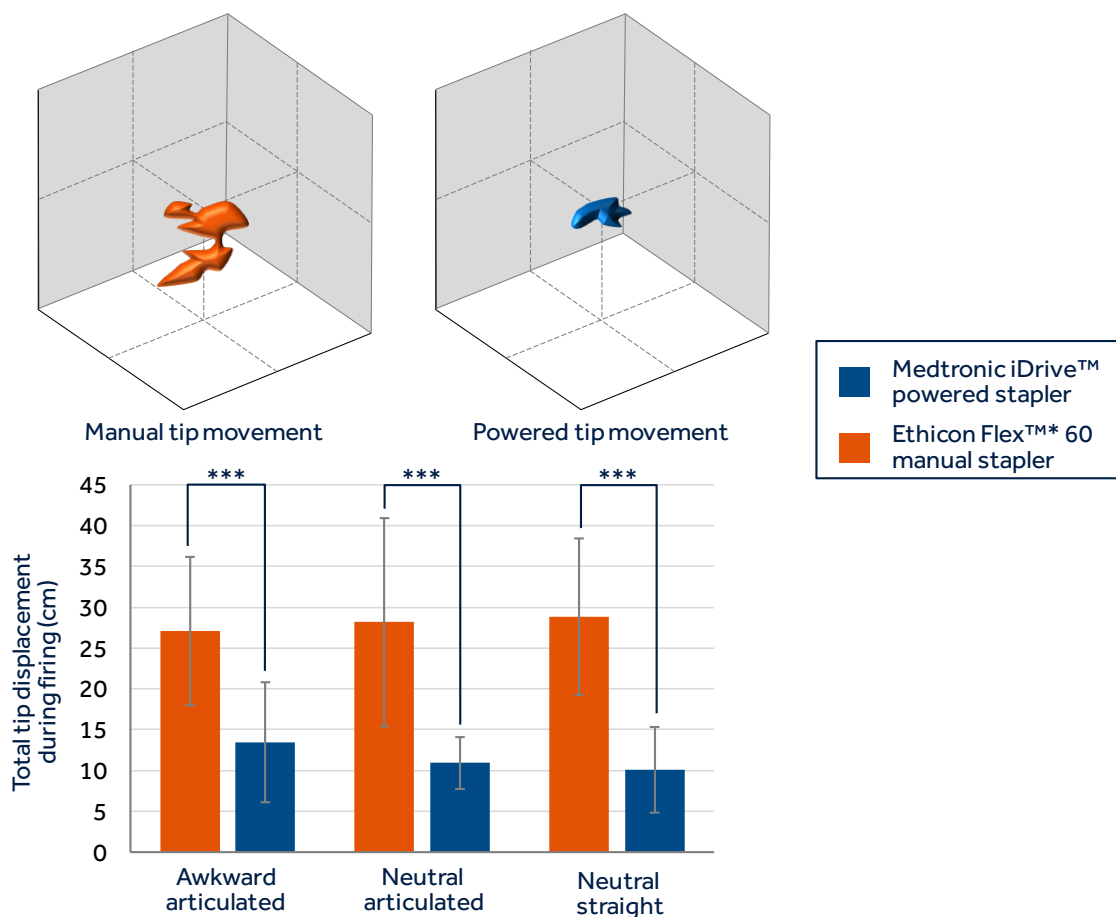

During the firing sequence (from tissue clamping to final release) of powered iDrive™ and manual staplers, the movement of the stapler tips was recorded across multiple trials.¹³⁰ The upper panels depict approximate volumes encompassing the range of movement in 3-dimensional space of the tip during firing. The measurement data for the total distance traveled through the 3-dimensional volume during a complete firing sequence are summarized below (means as bars, standard deviations as error bars) stratified according to firing position. “Awkward” indicated the operator arm position in an orientation that may occur to allow trocar access during laparoscopic surgery and articulation refers to the whether the stapler tip is deployed at an angle or straight. ***, $p < 0.001$.

Figure 8-2 Measured forces exerted on the operating hand during iDrive™ powered stapler versus manual stapler firing

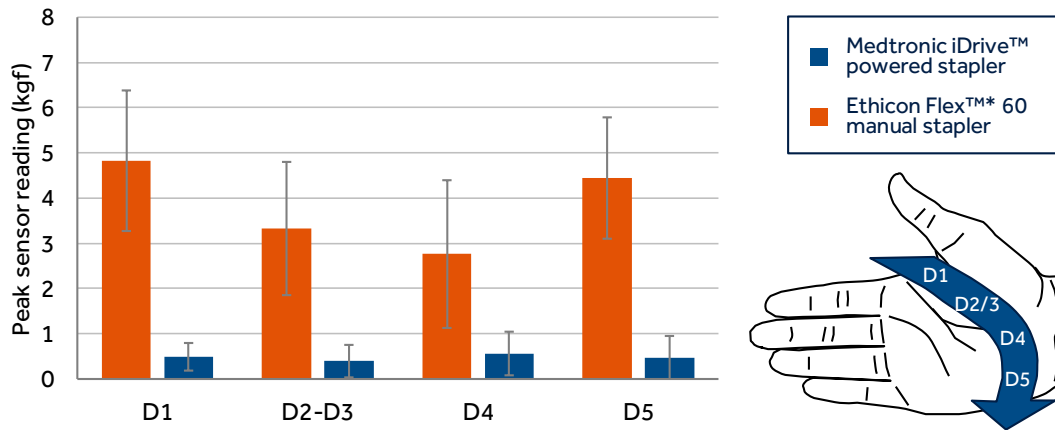

Means (bars) and standard deviations (error bars) are shown across maximum force measurements recorded during firing from sensors placed on iDrive™ powered and Echelon Flex™* manual stapling devices.¹³⁰ The labels on the hand schematic (D1 through D5) show the approximate locations where the relevant forces would be experienced. Note that these represent only an approximation since hand position and finger use differ considerably between how the powered and manual staplers are fired. Kgf, kilogram-force.

Figure 8-3 Surgeon scoring of functionality of iDrive™ powered stapler

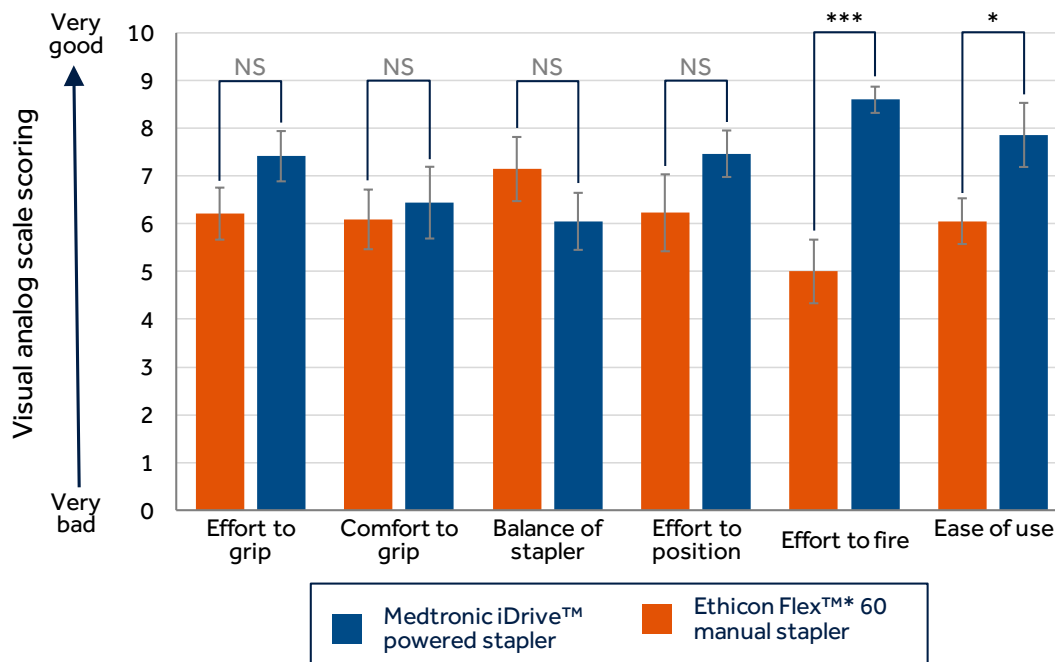

Means (bars) and standard deviations (error bars) are shown for surgeon ratings (n=10) on a visual analog scale across maximum force measurements recorded during firing from sensors placed on iDrive™ powered and Echelon Flex™* manual stapling devices.¹³⁰ * p 0.05; *** p < 0.001; NS, non-significant.

8.4. Powered versus manual stapling in clinical applications

In clinical application, claims data from the United States have been analyzed to compare outcomes in patients managed with a powered stapling device and those managed with manual staplers.^{67,68} In these reports, both powered and manual devices consisted of a mixture of Ethicon and Medtronic staplers, but there was a considerable imbalance between the composition of the powered and manual groups. Since the powered results consisted primarily of Ethicon and the manual consisted primarily of Medtronic, comparisons between manufacturers cannot be made as any difference will be confounded by the powered versus manual effect. Instead, results reported subsequently consider only all powered and all manual in aggregate.

Lower complication rates were observed with powered versus manual staplers, both significantly^{67,68} and non-significantly.⁶⁷ After pulmonary surgery, complications related to bleeding or the need for transfusion were significantly lower for powered devices compared to manual staplers, while pulmonary-related complications were non-significantly reduced (Figure 8-4).⁶⁷ The mean length of hospital stay was significantly reduced in the powered stapler group for patients who underwent pulmonary surgery (4.87 versus 5.88 days, p < 0.001) but exhibited no difference between the groups in the bariatric patients (Figure 8-5).

Figure 8-4 Operative complications with powered versus manual stapling devices used in pulmonary and bariatric procedures

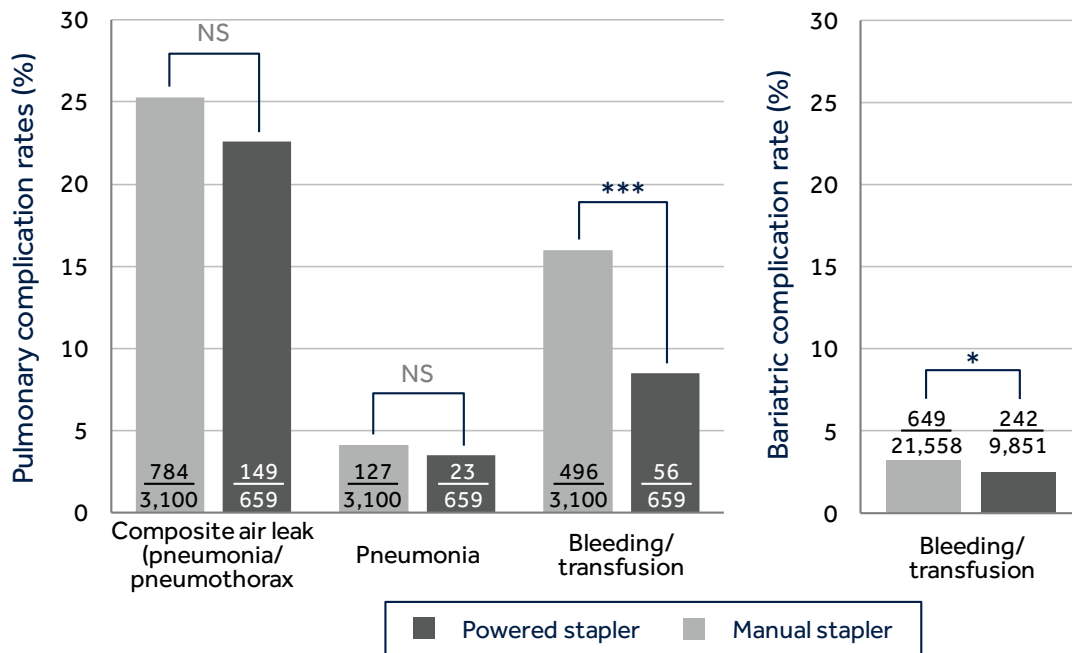

Data are shown from claims data for complications occurring after pulmonary⁶⁷ and bariatric⁶⁸ procedures with powered and manual stapler devices. Values superimposed on the bars indicate the number of patients with the complication shown over the total number of patients in the corresponding group. * p 0.05; *** p < 0.001; NS, non-significant.

Figure 8-5 Length of stay with powered versus manual stapling devices used in pulmonary and bariatric procedures

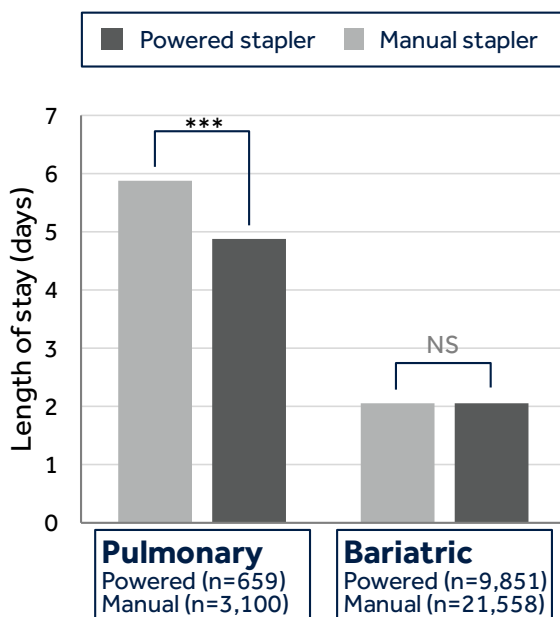

Data are shown from claims data for hospital length of stay after pulmonary⁶⁷ and bariatric⁶⁸ procedures with powered and manual stapler devices. Note that although results of statistical inference testing were reported, the uncertainties on the indicated values were not provided and thus no error bars are plotted. *** p < 0.001; NS, non-significant.

For both types of surgery, significant reductions in the associated adjusted mean total hospital costs were observed in the patients who received powered-stapler management compared to those who had manual staplers (Figure 8-6).^{67,68} In the pulmonary surgery analysis,⁶⁷ no significant differences were observed between the powered and the manual groups for medical/supply costs (\$5,234 versus \$5,672, $p = 0.405$ respectively) and operating room costs (\$7,095 versus \$7,187, $p = 0.735$, respectively). The total hospital costs, however, were significantly lower in the powered group versus the manual group: \$23,841 versus \$26,052, $p = 0.009$, corresponding to a decrease of 8.5%. Due to the equivalence of the supply and operating room costs between the groups, the authors suggest the cost difference is driven by the difference in length of hospital stay between the groups.

In the bariatric analysis (comprising both sleeve gastrectomy and gastric bypass),⁶⁸ the powered group versus manual group saw significantly reduced supply costs (\$4,629 versus \$5,217, $p = 0.011$), operating room costs (\$4,126 versus \$4,413, $p = 0.009$) and total hospital costs (\$12,415 versus \$13,547, $p = 0.003$) respectively (Figure 8-6). In contrast to the pulmonary procedure review, the mean length of stay between the groups was the same (both 2.05 days), indicating that the total cost difference of an 8.4% reduction in the powered versus the manual stapler group is driven by factors separate from the hospital stay.⁶⁸

Figure 8-6 Costs associated with powered versus manual stapling devices used in pulmonary and bariatric procedures

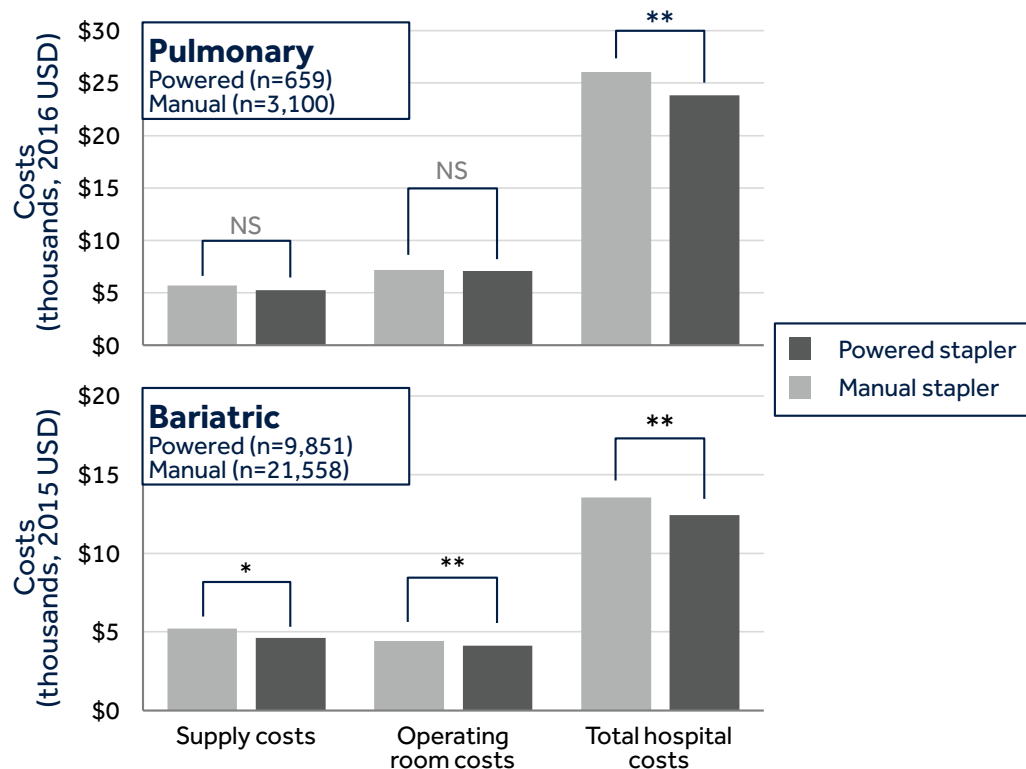

Data are shown from claims data for costs associated with pulmonary⁶⁷ and bariatric⁶⁸ procedures with powered and manual stapler devices. Supply costs comprised costs for medical and surgical supplies during the index hospital visit, operating room costs were any associated with the operating room, and total hospital costs included both of these as well as room and board costs. Note that although results of statistical inference testing were reported, the uncertainties on the indicated values were not provided and thus no error bars are plotted. * p 0.05; ** p < 0.01; NS, non-significant; USD, United States Dollars.

8.5. iDrive™ powered stapling system in clinical applications

Few studies found in the literature searches for the present dossier reported clinical, comparative investigations specifically referencing the use of the iDrive™ or iDrive™ Ultra stapler system (note that product details and distinctions are not always reported in the literature). Two that were identified included results from pulmonary⁷ and bariatric⁸ procedures.

A study of bleeding control during sleeve gastrectomy surgery was performed in patients (n = 207) randomized to management with either the iDrive™ powered stapling system or the Ethicon Echelon™* system (the Ethicon system was not specified as powered or manual).⁸ The outcome of interest related to intraoperative hemostatic control, where the number of patients who required clips for control in each group was noted, as well as the total number of clips used (Figure 8-7). As this study was a conference presentation, protocol details and extended analyses of the results were not available. Statistical inference testing, for example, was not reported in the original study, however, post hoc testing indicates that the iDrive™ stapling system group was associated with significantly lower requirement for clips for hemostasis (Chi-squared, two-tailed, p = 0.0011).

Figure 8-7 Hemostatic control in a randomized trial of sleeve gastrectomy with iDrive™ versus Echelon™* stapling systems

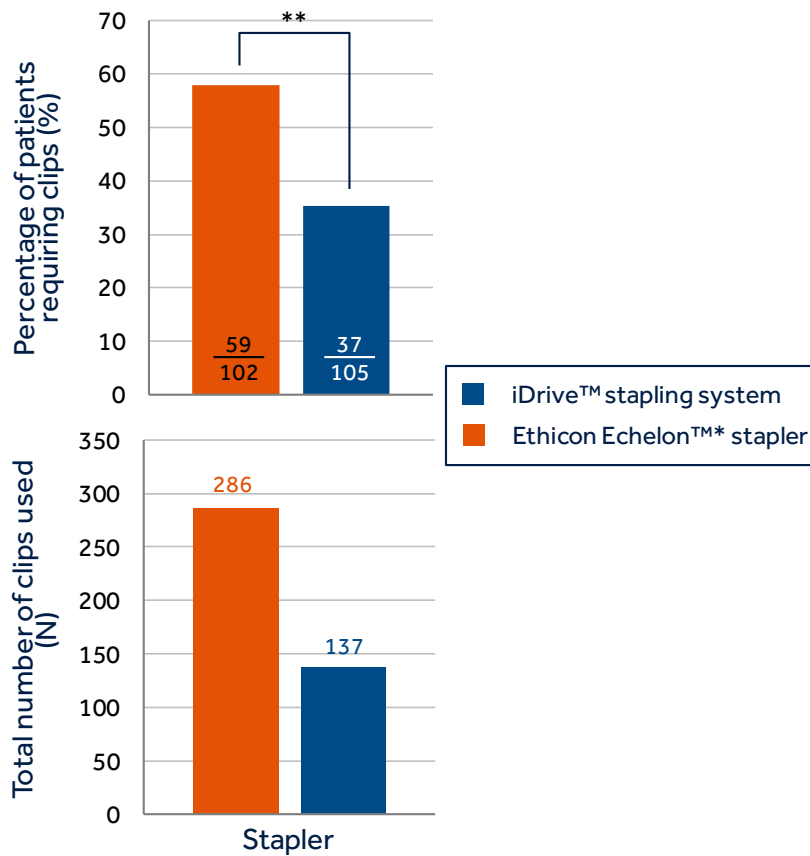

Data are shown⁸ from the report of Layani and Gautam, 2017. The number of patients requiring clips for hemostatic control was lower in the iDrive™ treatment group; the authors did not perform inferential statistical testing, however in the present dossier, the result is suggested to be significantly different according to the Chi-squared test. The count of staples used in each group was also reported. ** $p < 0.01$.

A randomized study was performed involving 40 patients with severe emphysema undergoing bilateral lung volume reduction surgery.⁷ Since both lungs were due to be resected, the randomization was performed to determine which lung would be managed with the iDrive™ stapling system while the contralateral lung would be managed with the manual Endo GIA™ stapler. The primary endpoint of the study was the volume of air leak after extubation post surgery.

The results suggested statistically non-significant differences in the primary outcome of air leak immediately after extubation (Figure 8-8). Patients managed with the iDrive™ powered stapler had non-significantly less volume of air leak compared to the conventional Endo GIA™ manual device. Among secondary outcomes, results were comparable for air leak on the first postoperative day and non-significantly lower for the duration of required drainage therapy (Figure 8-8).⁷

Figure 8-8 Outcomes after lung volume reduction surgery with the iDrive™ stapling system versus the Endo GIA™ conventional stapler

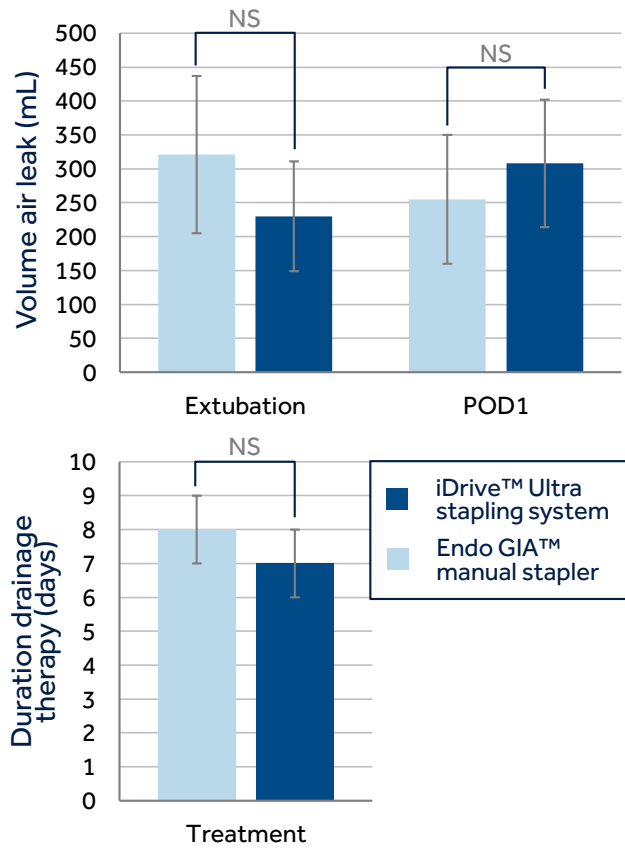

Data⁷ are shown from Akil et al., 2019 of a prospective trial involving bilateral lung volume reduction surgery, where the stapling with the powered iDrive™ Ultra stapling system was randomized to one lung and the manual Endo GIA™ stapler applied to the contralateral lung. The outcome of air leak volume is shown according to the time at which the measurement was determined: immediately after extubation or the first postoperative day. NS, non-significant; POD1, postoperative day 1.

8.6. The Signia™ stapling system

Building on the feature improvements of the iDrive™ Ultra powered device, the Signia™ stapling system represents the next advancement in powered stapling technology from Medtronic plc. As with the development of Tri-Staple™ technology, the Signia™ stapling system features were designed to address challenges that have been encountered by surgeons in real-world practice. These include:

- Gauging the appropriate amount of force to achieve tissue compression⁷⁸
- Accounting for differences in required force and firing speed depending on tissue type³⁴
- Adjusting the firing speed to improve staple formation³
- Reported contributors to stapling adverse events²⁶ such as, but not limited to:
 - Problems with articulation or rotation of the stapler
 - Squeezing the stapler handle requires more force than usual
 - Staples of the wrong size are used
 - Stapler is applied across a harder material (such as previously deployed staple or surgical instrument), resulting in device damage and inappropriate staple formation
 - Tissue in the stapler jaws is distributed unevenly

Addressing these concerns requires good practice and appropriate use of stapling technology. The Signia™ stapling system incorporates tissue-sensing features and provides feedback to the surgeon with the aim of providing information to assist in reducing the likelihood of adverse surgical events.

8.6.1. Signia™ stapling system technology

The Signia™ stapling system is of modular design, consisting of disposable and reusable parts, and both sterile and non-sterile components (Table 8-1, Figure 8-9). Refer to the current Signia™ stapling system user manual and instructions for use for the most up-to-date information regarding proper usage and maintenance.

Table 8-1 Signia™ stapling system components

Component	Description
Power handle	Non-sterile, reusable. Not to be discarded after each procedure, unless the end-of-life status is displayed. Display: Provides visual feedback regarding cartridge detection, status, and force feedback for automatic speed setting.
Power shell	Sterile, disposable. Provides a sterile barrier between the power handle and the operating environment. Follow instructions regarding preservation of sterile field during application of the shell around the handle.
Linear adapter	Sterile (institutional processing), reusable. Provides the connection between the power handle and the intelligent-chip-enabled Tri-Staple™ 2.0 cartridge

Figure 8-9 Components of the Signia™ stapling system

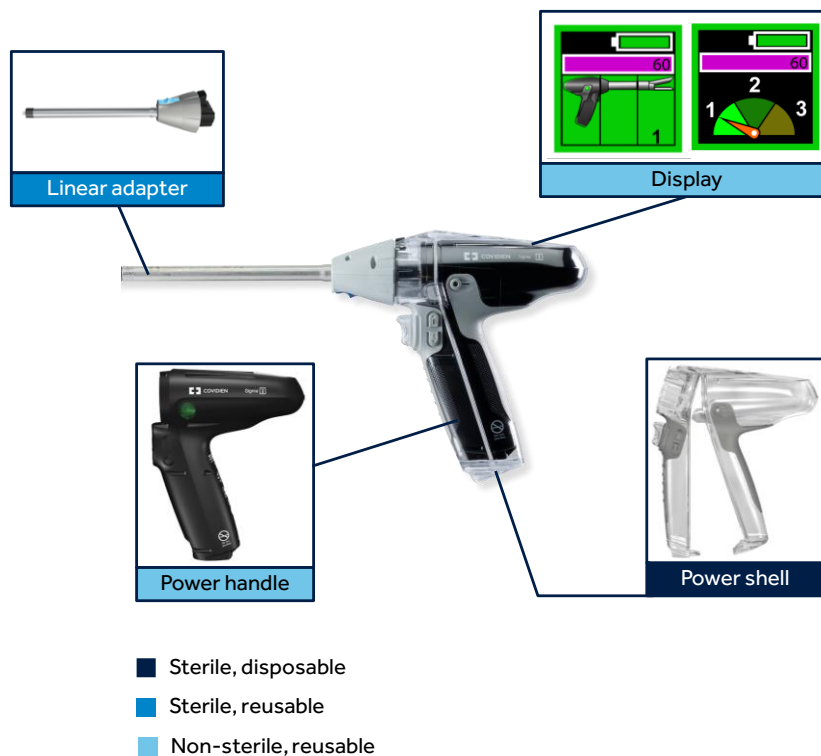

8.6.1.1. Tissue sensing

A central component of the Signia™ stapling system is its force-sensing technology. During the initial clamping of tissue, the clamp force exerted by the closure of the device around the target tissue is measured. These data inform the initial firing speed setting. During firing, the forces required to deploy the staples are measured, providing feedback regarding tissue properties and allowing for real-time adjustment of firing speed (see section 8.6.2). The force detection includes an upper threshold of excessive force, which, if reached, will prevent the stapler from firing and a warning is issued to alert the surgeon.

8.6.1.2. Audio and visual feedback

The intelligence-enabled Signia™ stapling system acts as a partner to the surgeon during an operation, providing real time feedback about measured force. Communication is achieved through audio signals and visual displays to keep the surgeon informed of the status of the device.

8.6.1.3. Powered articulation and rotation

Changing the angle of the cartridge relative to the linear adapter and its rotation are controlled electronically via buttons on the handle. This live control obviates, for example, the need for preorientation of the device by hand prior to application, or the bracing of the tip against structures inside the body to change the angle.

8.6.1.4. Cartridge compatibility

The Signia™ stapling system is compatible with Medtronic plc reloads, accepting Endo GIA™ Universal and Tri-Staple™ technology stapler reloads. The full features of the Signia™ system, however, are only available with the Tri-Staple™ 2.0 Intelligent technology, in which the cartridges are enabled with a chip that displays tissue-sensing feedback in response to forces exerted on the target tissue.

8.6.2. Adjusting firing speed

The Signia™ stapling system adjusts the staple firing speed based on data from the force sensors in the powered handle. Since firing speed has been associated with rate of proper staple formation in model systems,^{3,69} measurement of the stapler firing force is used to adjust the speed of firing according to an algorithm (Figure 8-10). The application of force criteria to inform device settings of firing speed provides reproducibility of the stapling system response to changing tissue thicknesses.

Figure 8-10 Adaptive Firing™ algorithm

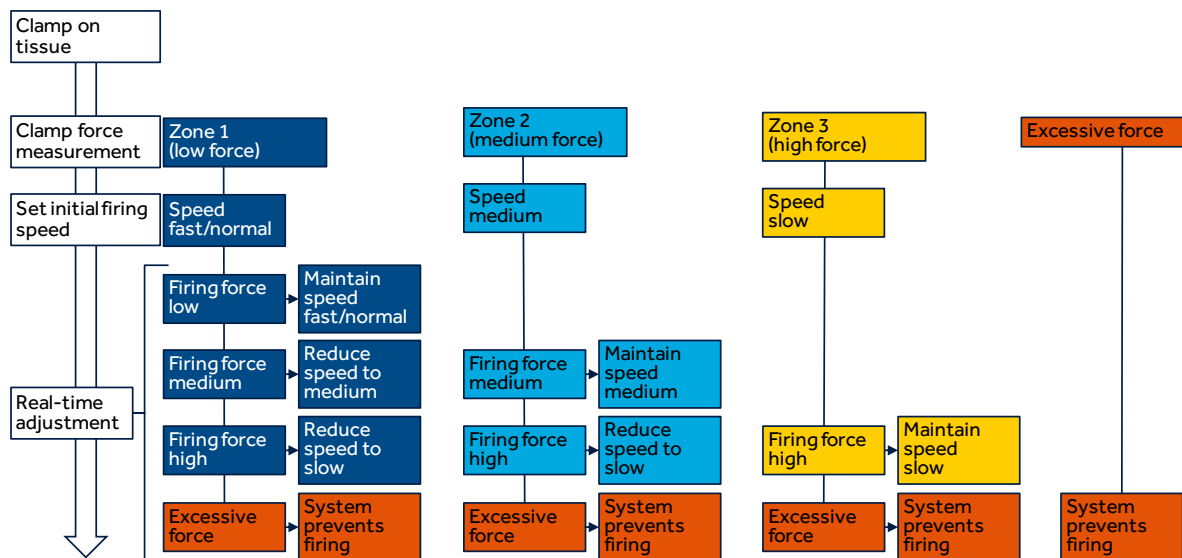

After clamping of tissue, the exerted force is measured, and a zone is selected to determine the initial firing speed. During deployment, the firing force is measured to enable regulation of the firing speed if the (increasing) exerted force required to fire staples indicates thicker tissue.

The effect of this automatic firing speed regulation on rate of proper staple formation has been estimated using a mechanical firing device, ex vivo porcine stomach tissue, and a statistical model of staple formation using Tri-Staple™ technology.^p For thicker tissues, faster firing speeds are expected to result in greater percentages of malformed staples (Figure 8-11).

^{p,†}Internal white paper. Technical summary: Feasibility testing and development of Adaptive Firing™ technology to improve surgical stapler performance. Ex vivo porcine stomach model with firing using a mechanical device (Instron). Tested total of 72 firings using tan, purple, and black 60 mm reloads at firing speeds of faster, medium, and slower across average, thick, and extra-thick tissue. Level of undercrimped and malformed staples were assessed. Percentages reported represent expected malformation rate under the indicated conditions of tissue thickness and firing speed based on a model developed using porcine tissue. Preclinical results may not correlate with clinical performance in humans.

Figure 8-11 Firing speed adjustment and proper staple formation

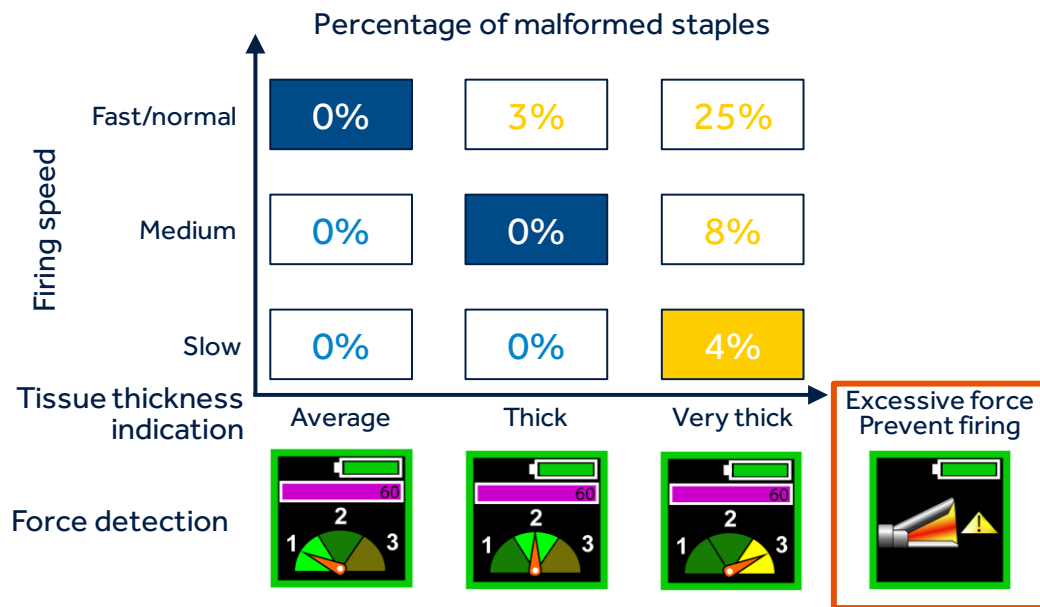

Expected malformation rates are shown for purple Tri-Staple™ technology reloads as determined from models derived from experiments on ex vivo porcine tissue.^q For average tissue thickness and appropriate cartridge size selection, firing speed is expected to have little impact on the percentage of malformed staples. At the next thicker range of tissue, faster firing speeds would be associated with more malformed staples. At the thickest tissue levels, the slowest firing speed would be associated with the lowest rate of malformed staple production. Data were determined using a mechanical device. In application of the Adaptive Firing™ algorithm to the Signia™ stapling system device, the surgeon would be informed of the force-sensing feedback according to the display shown at bottom. If the force exceeds an internal threshold, the stapler is prevented from firing.

8.6.3. Device usability

The usability of the Signia™ stapling system was assessed via questionnaire after training and simulated surgery sessions involving surgeons and nurses at multiple centers in the United States.^r Nurses (n=50) and surgeons (n=38) were recruited across multiple sessions to perform surgical tasks in porcine models after device-specific training. The group consisted of a mixture of users who typically use Covidien (now Medtronic plc) and Ethicon devices and represented extensive surgical experience with collectively over 500 years of nursing experience (average 12.3±9.2 years, range 1-41) and over 400 years of surgical

^qInternal white paper. Technical summary: Feasibility testing and development of Adaptive Firing™ technology to improve surgical stapler performance. Ex vivo porcine stomach model with firing using a mechanical device (Instron). Tested total of 72 firings using tan, purple, and black 60 mm reloads at firing speeds of faster, medium, and slower across average, thick, and extra-thick tissue. Level of undercrimped and malformed staples were assessed. Percentages reported represent expected malformation rate under the indicated conditions of tissue thickness and firing speed based on a model developed using porcine tissue.

^r Internal study, RE00024826, rev D. Summative usability report, Signia™ stapling system. Testing was performed with multiple cohorts of individual surgeons and paired surgical teams consisting of a surgeon and surgical technician or registered nurse. Participants were recruited via a third party and were paid honoraria by Medtronic plc. Surgery simulated in porcine models during which surgeons completed approximately 281 staple fires of 95 Endo GIA Tri-Staple™ reloads, 91 Tri-Staple™ 2.0 reloads, and 105 Tri-Staple™ 2.0 cartridges.

experience (average 11.5 ± 7.6 years, range 1-29). The totals and averages exclude those for whom the years of experience data were not recorded; therefore, the total years for each group will be higher (Figure 8-12).

Figure 8-12 Signia™ stapling system usability study participant device and practice data

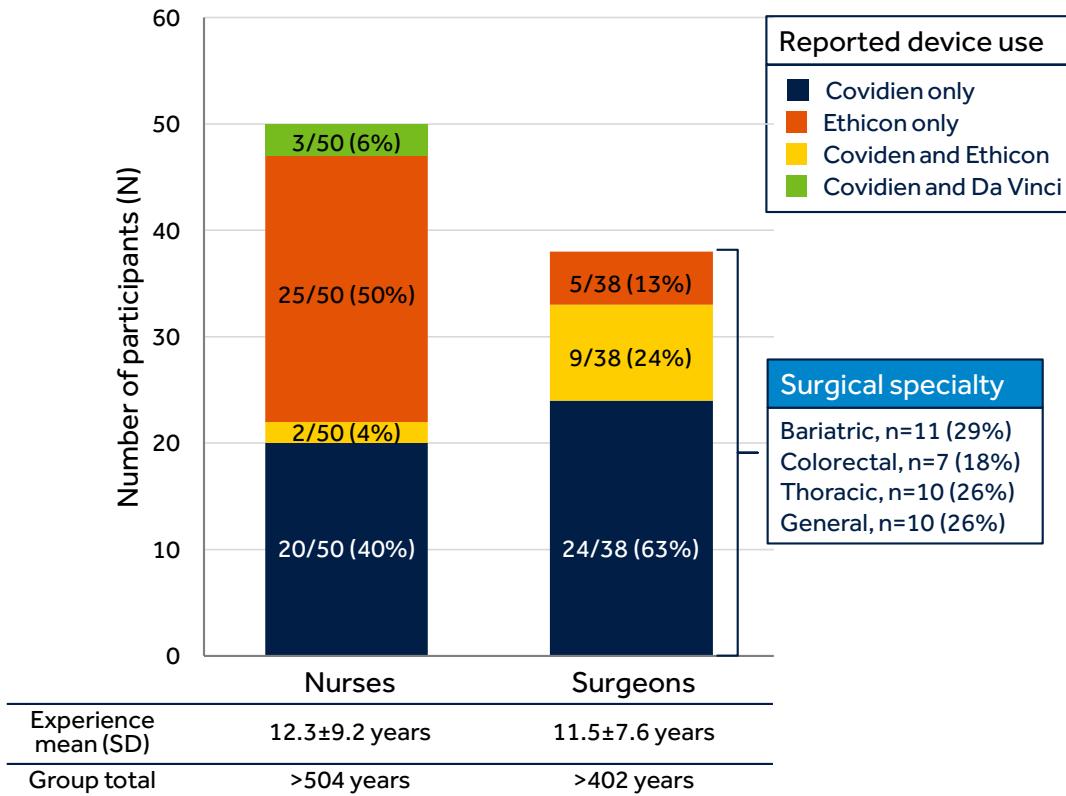

Data are shown for the internal report of Signia™ stapling system usability testing among nurses (50) and surgeons (38).† Values on the bars indicate the counts of users who indicated usual device usage, along with the percentage in each group. Among surgeons at right, the composition of surgical specialty is shown.

The results indicate that the majority of participants found the Signia™ stapling system usable and clinically acceptable (Figure 8-13). Nurses, who would participate in the preparation of the device, found the time required clinically acceptable (100%) and that they could accomplish the preparation without compromising sterility of the device (100%). Among surgeons, all functions related to stapling could be executed (clamping/unclamping of tissue, articulation and rotation of the stapler, firing the stapler, and retracting the blade, 100%) and with one hand (100%). The device was found to produce acceptable initial tissue compression (100%) and to provide force feedback data useful in supporting decision making (97% of surgeons who were asked, 100% of surgeons who made use of the feature with multiple force settings). Of those surgeons who provided comments regarding the clinical utility of the force-feedback data, most suggested that the data would aid in the selection of appropriate cartridges for the tissue to be stapled (10 comments, 90%). Overall, 97% of surgeons found the Signia™ surgical stapling system physically comfortable to use.

Figure 8-13 Select usability assessment post training and simulated surgery

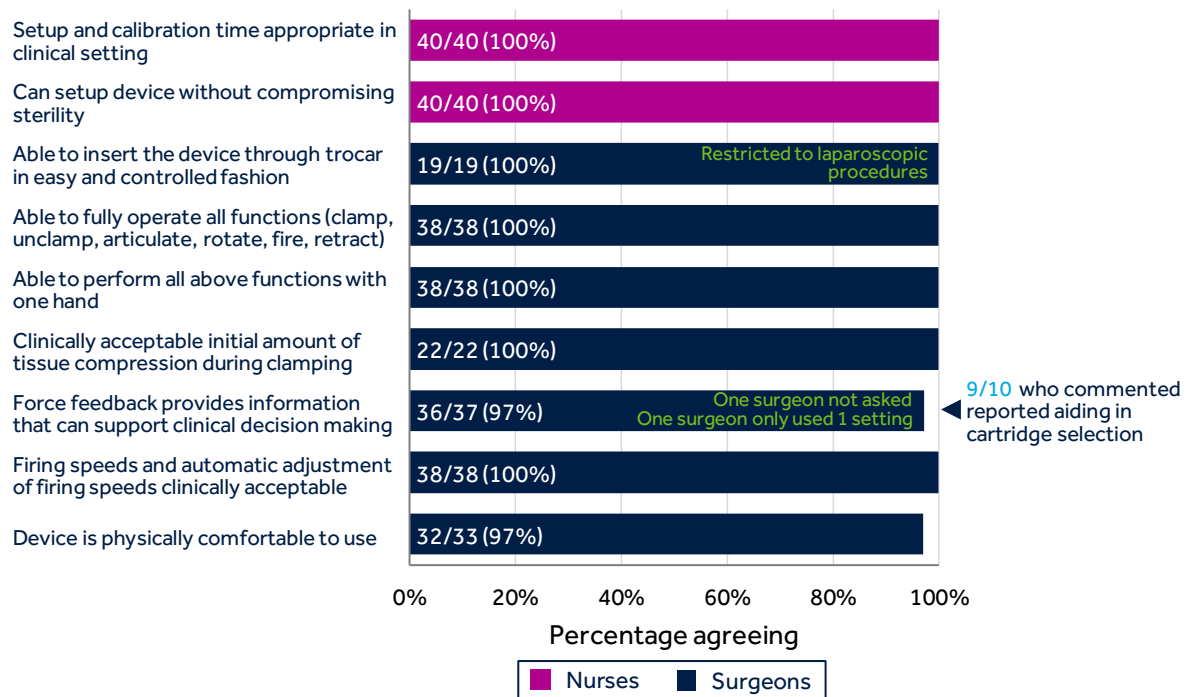

Select responses are shown for the standardized questionnaire administered to participants after a usability assessment of the Signia™ stapling system in simulated surgery in a porcine model.⁵ Values shown are the number of respondents agreeing with the statement and the corresponding percentage. Among the surgeons who responded to the question regarding whether the force feedback provides useful information to support decision making, 10 respondents provided free-text comments on how the information may be of use; of these 10, 9 reported that it would help with selection of the appropriate cartridge size (staple height).

⁵ Internal study, RE00024826, rev D. Summative usability report, Signia™ stapling system. Testing was performed with multiple cohorts of individual surgeons and paired surgical teams consisting of a surgeon and surgical technician or registered nurse. Participants were recruited via a third party and were paid honoraria by Medtronic plc. Surgery simulated in porcine models during which surgeons completed approximately 281 staple fires of 95 Endo GIA Tri-Staple™ reloads, 91 Tri-Staple™ 2.0 reloads, and 105 Tri-Staple™ 2.0 cartridges.

8.6.4. The Signia™ stapling system in clinical application

Fewer published clinical studies of the real-world application of the Signia™ stapling system are currently available compared to those identified for the iDrive™ powered stapler. Thus far, conference reports of Signia™ stapling technology use in sleeve gastrectomy surgeries have been identified.^{70,71} One of those reports noted no complications in the 30-day post surgery period among 30 patients; the authors describe this result as a decrease in incidence of complications, but statistical analyses were not presented.⁷¹ A case series of 5 patients with large degenerative aneurysmal brachiocephalic arteriovenous fistula saw 2 treated with the Signia™ stapling system to correct the defect using sleeve-like fistulectomy to divide the vessel.⁷² Case reports of the Signia™ stapling system using Tri-Staple™ technology with curved tip reloads have also been published for transection of liver parenchyma during hepatic resection for hepatocellular carcinoma⁵⁹ and for pericardiectomy and bronchial stump closure during bilobectomy for non-small cell lung cancer.⁷³ The authors of the pulmonary surgery study noted especially the advantages of the Adaptive Firing™ technology to assist in determining the appropriate cartridge size.⁷³

From the foundation established by these preliminary reports, additional clinical results from the use of the Signia™ stapling system are expected in the future. A registered, prospective, clinical, postmarket, observational trial of an estimated 127 patients (53 abdominal surgery, 74 thoracic) is currently underway to confirm the safety and performance of using the Signia™ stapling system with Tri-Staple™ 2.0 Intelligent Reload technology at multiple international centers (NCT03515811).

APPENDIX

STUDY DATA TABLES AND REFERENCES

9. Appendices

9.1. Tri-Staple™ technology evidence summary

Below is a summary of recovered studies reporting outcomes related to the use of Tri-Staple™ technology in human surgical settings (Table 9-1). Results are sorted in decreasing order according to level of evidence as per the Oxford Centre for Evidence-Based Medicine grading system using the previous (2011) and current (version 2) descriptions. The earlier version provides finer distinction between evidence types and both are presented for informational purposes. “Legacy” devices refer to Medtronic-supplied stapling precursors to Tri-Staple™ technology in which the staples in all 6 staple lines (three on either side of the tissue dividing line) are of equal height.

Table 9-1 Tri-Staple™ technology evidence summary

Study	Country	Data	Study type	Surgery	Comparison	LOE 2011	LOE v2	Patients	Main outcome
Okami et al., 2017,⁴	Japan	Prosp	RCT	Pulmonary resection	Tri-Staple vs. legacy	1b	2	61	Patient-side: non-significantly lower rates of air leak and staple line oozing. Excised tissue side: significantly higher proper staple formation rates ($p < 0.001$).
Derici et al., 2018,³⁸	Turkey	Prosp	Consecutive patients	Sleeve gastrectomy	Tri-Staple vs. legacy	2b	3	70	Significantly higher resistance to intragastric pressure measured on excised stomach ($p = 0.005$)
Nienhuijs et al., 2016,³⁹	Netherlands	Retro	Cohort	Sleeve gastrectomy	Tri-Staple vs. legacy	3b	4	1,041	Tri-Staple use associated with significantly lower odds of anastomotic leak ($p = 0.009$)
Man-i et al., 2015,⁴³	Japan	Prosp	Matched control	Gastrointestinal resection	Tri-Staple vs. Endopath	3b	4	42	Non-significantly lower overall morbidity (26% vs. 36%) and anastomosis-related complications (16% vs. 4%) significantly shorter median LOS (11 days vs. 14 days, $p = 0.02$)
Scuderi et al., 2014,²²	Belgium	Retro	Case control	Hepatic resection	Tri-Staple vs. no staple	3b	4	92	Tri-Stapled group had larger and more tumors removed; nevertheless, also had non-significantly shorter OP time, non-significantly different LOS (longer median, shorter mean)
Kawaida et al., 2018,⁴⁹	Japan	Retro	Case series	Distal pancreatectomy	Single arm (Tri-Staple)	4	4	75	Observed pancreatic fistula rate (9.3%) lower than rates observed in global meta-analysis

Study	Country	Data	Study type	Surgery	Comparison	LOE 2011	LOE v2	Patients	Main outcome
									(29%), fixed-height staple (33%) and Japanese (23%) studies
Watanabe et al., 2016,⁴⁵	Japan	Retro	Case series	Low anterior resection	None	4	4	27	Procedures were completed successfully. No comparisons were made. Low complication rates (intraoperative, 0%; postoperative, 11%). No anastomotic leakages.
van Vugt et al., 2015,³⁵	Netherlands	Survey	NA	Low anterior resection	None (or current alternative)	5	5	35	93% of respondents consider the device clinically acceptable; over 80% rate the device better for visibility, maneuverability, lower pelvis access, and distal resection margin than currently used devices

LOE 2011; Oxford Centre for Evidence-Based Medicine, levels of evidence 2011 version; LOE v2, Oxford Centre for Evidence-Based Medicine, level of evidence grades version 2; LOS, length of (hospital) stay; NA, not applicable; Prosp, prospective; RCT, randomized controlled trial; Retro, retrospective. Tri-Staple™ technology and Endopath™* are registered trademarks of their respective holders.

9.2. Tri-Staple™ technology with reinforced reload evidence summary

Below is a summary of recovered studies reporting outcomes related to the use of Tri-Staple™ technology with reinforced reload in human surgical settings (Table 9-2). Results are sorted in decreasing order according to level of evidence as per the Oxford Centre for Evidence-Based Medicine grading system using the previous (2011) and current (version 2) descriptions. The earlier version provides finer distinction between evidence types and both are presented for informational purposes. “Oversewn” refers to reinforcement of the staple line with additional sutures.

Table 9-2 Tri-Staple™ technology with reinforced reload evidence summary

Study	Country	Data	Study type	Surgery	Comparison	LOE 2011	LOE v2	Patients	Main outcome
Kondo et al., 2019,⁵⁰	Japan	Prosp	RCT	Distal pancreatectomy	RR Tri-Staple vs. Tri-Staple bare	1b	2	120	Non-significantly lower rate of CR-POPF overall (16.3% vs. 27.1%); significantly decreased for thinner pancreatic transection line (4.5% vs. 21%, p = 0.01)
Ruiz-Tovar et al., 2018,⁴⁰	Spain	Prosp	RCT	Sleeve gastrectomy	RR Tri-Staple vs. Tri-Staple oversewn	1b	2	100	Significantly lower PONV interfering with drinking (12% vs. 30%, p = 0.027)
Shigeeda et al., 2019,⁴¹	Japan	Retro	Matched control	Pulmonary wedge resection	RR Tri-Staple vs. non-reinforced Ethicon staple	2b	3	291	Significantly lower rate postoperative air leakage (1.9% vs. 13.5%, p = 0.002)
Pulvirenti et al., 2019,⁵²	Italy	Retro	Matched control	Distal pancreatectomy	RR Tri-Staple vs. ultrasonic dissection	2b	3	184	Significantly lower CR-POPF in RR group (12% vs. 40%, p < 0.001).
Karabicak et al., 2017,⁴⁷	Japan	Retro	Cohort	Distal pancreatectomy	RR Tri-Staple vs. other closures	2b	3	169	Non-significantly lower rate of complications (47% vs. 61%) and 30-day readmissions (5.6% vs. 0%)
Yamashita et al., 2017,⁵¹	Japan	Retro	Consecutive patients	Distal pancreatectomy	RR Tri-Staple vs. Tri-Staple bare	2b	3	42	Significant lower rate of CR-POPF (5% vs. 30%, p = 0.0216)
Deguchi et al., 2019,⁴²	Japan	Retro	Matched control	Pulmonary radical lobectomy (NSCLC)	RR Tri-Staple vs. Tri-Staple bare	3b	4	546	Significantly lower rate postoperative air leakage (9.6% vs. 22.4%, p = 0.006)

Study	Country	Data	Study type	Surgery	Comparison	LOE 2011	LOE v2	Patients	Main outcome
Hayashibe et al., 2018,⁴⁶	Japan	Retro	Case-control	Distal pancreatectomy	RR Tri-Staple vs. Tri-Staple bare	3b	4	51	Significantly lower CR-POPF (0% versus 18.4%) and significantly shorter LOS (17.7 days versus 24.3 days). Operative time and blood loss were non-significantly lower.
Nagahisa et al., 2017,⁴⁴	Japan	Retro	Case-control	Gastrointestinal resection	RR Tri-Staple vs. Tri-Staple bare	3b	4	130	Non-significantly lower rate of anastomotic complications (0% vs. 3.3%)
Kawai et al., 2017,⁴⁸	Japan	Prosp	Observational	Distal pancreatectomy	None	4	4	105	Complications reported: 12.4% CR-POPF, 10.5% staple line bleeding, 2.9% damage to pancreatic parenchyma at staple line. Authors report expected CR-POPF rate was 6% but also compare their multicenter incidence to literature reports ranging from 9.6% to 22.9% for non-reinforced staples.

CR-POPF, clinically-relevant postoperative pancreatic fistula; LOS, length of (hospital) stay; NSCLC, non-small cell lung cancer; PONV, postoperative nausea and vomiting; Prosp, prospective; RCT, randomized controlled trial; Retro, retrospective; RR Tri-Staple, Tri-Staple™ technology with reinforced reload.

9.3. Excluded comparative studies

The following studies were recovered in the search and report on competitor data but were excluded from further data analysis due to the unbalanced nature of the comparisons performed. In each case, results purporting to show differences between manufacturers instead include the confounding factor of using powered (Ethicon) versus manual (Medtronic). Among these is one study of clinical and cost outcomes of powered and manual stapler use from a claims database in the United States where authors extracted data for powered Ethicon and powered Medtronic devices, but did not report the comparison, only that of Ethicon powered versus Ethicon manual and Ethicon powered versus Medtronic manual.¹³²

Table 9-3 Recovered studies excluded from data analysis

Author	Area	Procedure	Outcome	Comparators	Evaluation
Roy et al., 2018,¹³²	Bariatric	RYGB, SG	Costs	Powered and manual, Ethicon and Medtronic staplers	Claims data were analyzed for powered and manual stapler claims including Ethicon and Medtronic products. Cost comparisons were reported between powered and manual Ethicon devices, demonstrating benefit of powered over manual. The only Ethicon to Medtronic comparison made, however, was powered Ethicon versus manual Medtronic, again demonstrating benefit. Authors explicitly did not analyze powered Ethicon versus powered Medtronic.
Miller et al., 2018,⁶⁷	Thoracic	VATS lobectomy	Costs, LOS, complications	Powered versus manual staplers, database search for Ethicon and Medtronic product codes	Claims data were analyzed for powered and manual stapler claims. Table 4 includes a non-stratified comparison of all powered versus all manual, but Table 5, purporting to stratify Ethicon versus Medtronic outcomes indicates that the Ethicon outcomes were for powered staplers, while the Medtronic outcomes were for manual.
Thompson et al., 2018,¹³³	Preclinical	Porcine colon	Mucosal capture	Echelon Flex Powered Plus Stapler, Endopath ECHELON Reloads GST blue or green; Endo GIA Ultra Universal Standard Tri-Staple technology purple	Authors note potential impact of design differences, waiting period after compression and before stapling, and use of powered vs. manual stapler. Also did not evaluate thicker tissue that may have been more suited to the Tri-Staple purple.

Author	Area	Procedure	Outcome	Comparators	Evaluation
Eckert et al., 2018,¹³⁴	Preclinical	Porcine lung	Air leak, proper staple formation rate	Echelon Flex GST versus Endo GIA Universal with Tri-Staple	Authors note staples applied with "fundamentally different staplers" and differences will include the powered delivery in the Echelon staples versus the manual delivery of the Medtronic Tri-Staple technology
Roy et al., 2017,⁶⁸	Bariatric	RYGB, SG	Costs, LOS, complications	Powered and manual, Ethicon and Medtronic staplers	Claims data were analyzed for powered and manual stapler claims including Ethicon and Medtronic products. For all types of bariatric procedures, powered comprised 92% Ethicon, 8% Medtronic, manual, 45% Ethicon, 58% Medtronic (unclear origin of total in latter manual group). Comparisons reported between all powered and all manual, subsequently by manufacturer, but this comparison is confounded by only comparing Ethicon powered vs. Medtronic manual.

LOS, length of (hospital) stay; RYGB, Roux-en-Y gastric bypass; SG, sleeve gastrectomy; VATS, video-assisted thoracic surgery.

10. Structured literature search details

Structured searches were performed (November 2019) to identify literature reporting on Tri-Staple™ technology in benchtop, preclinical animal and clinical studies (Table 10-1). Search strings in PubMed are presented and were translated into EMBASE strings to execute parallel retrieval of studies indexed in that database. Results were combined for screening and processing using the *Sourcerer* web application. A total of 1,118 articles were returned from PubMed and EMBASE, reduced to 885 after deduplication between the two databases, which were subjected to screening at the title and abstract level. Exclusion criteria (for articles to be used for data analysis) included articles published before 2009, those that did not report stapling outcome data, not the targeted stapling technology (such as skin staplers) and procedures not under study (including hernia repair and hemorrhoid procedures).

Table 10-1 Structured searches in PubMed to identify relevant Tri-Staple™ technology data

Index	Aim	Search string	Hits
#01	Named Tri-Staple	Tri-Staple[tw] OR Tri-stapler[tw] OR Tri-staples[tw] OR Tri-stapletm[tw] OR tristaple[tw] OR tristapler[tw] OR tri-staple*[tw] OR tristaple*[tw]	29
#02	Named I-drive	Idrive[tw] OR idrivetm[tw] OR signia[tw] OR signiatm[tw]	13
#03	Named competitor devices	"Echelon"[tw] OR "Echelonm"[tw] OR "Echelon circular"[tw] OR "Echelon Flex"[tw] OR "Endopath"[tw] OR "Endopathm"[tw] OR (("aeon"[tw] OR aeon*[tw] OR "justright"[tw] OR "justrightm"[tw] OR "just right"[tw]) AND (stapler[tw] OR stapling[tw] OR staple[tw] OR staples[tw]))	504
#04	MDT staplers and cartridges	"Endo GIA"[tw] OR "Endo GIAm"[tw] OR "radial reload"[tw] OR "black reload"[tw] OR "curved tip reload"[tw] OR "reinforced reload"[tw]	343
#05	Generic stapling	Staple[tiab] OR staples[tiab] OR stapling[tiab] OR stapled[tiab] OR "surgical stapling"[MeSH] OR "surgical staplers"[MeSH] OR "surgical stapler"[tw] OR "surgical staplers"[tw] OR "powered stapler"[tw] OR "powered stapling system"[tw] OR "powered stapling"[tiab]	16,858
#06	Surgical context	Surgery[tiab] OR surgeries[tiab] OR operation[tiab] OR operations[tiab] OR "Surgical Procedures, Operative"[MeSH] OR "Specialties, Surgical"[MeSH] OR "surgery"[Subheading] OR ((surgical[tw] OR operative[tw]) AND (procedures[tw] OR procedure[tw])) OR "operative surgical procedures"[tw] OR Thoracic[tiab] OR pulmonary[tiab] OR bariatric[tiab] OR (colorectal[tiab] AND (surgery[tiab] OR resection[tiab] OR anastomosis[tiab])) OR colectomy[tiab] OR pneumonectomy[tiab] OR pneumectomy[tiab] OR "pneumonectomy"[tiab] OR "wedge resection"[tiab] OR "gastrointestinal resection"[tiab]	4,770,197
#07	Named manufacturer (MDT)	Medtronic[tw] OR Covidien[tw] OR Tyco[tw] OR Valleylab[tw] OR Autosuture[tw]	5,875
#08	Named manufacturer (competitor)	"johnson & johnson"[tw] OR "ethicon"[tw] OR Lexington[tw] OR ("purple"[tiab] AND "surgical"[tiab]) OR "border surgical"[tw] OR "Frankenman"[tw]	2,368

Index	Aim	Search string	Hits
#09	Stapling adverse events	Failure[tiab] OR "equipment failure"[MeSH] OR "equipment failure analysis"[MeSH] OR leak[tiab] OR leakage[tiab] OR "anastomotic leak"[MeSH] OR misfire[tiab] OR tearing[tiab] OR shear[tiab] OR "adverse event"[tiab] OR "adverse events"[tiab] OR "misfire"[tw] OR "misfires"[tw] OR "misfiring"[tw]	1,001,522
#10	Stapling adverse outcomes/complications	Bleed[tiab] OR bleeds[tiab] OR bleeding[tiab] OR hemorrhage[tiab] OR haemorrhage[tiab] OR hemorrhages[tiab] OR haemorrhages[tiab] OR hemorrhage[MeSH] OR sepsis[tiab] OR sepsis[MeSH] OR death[tiab] OR deaths[tiab] OR mortality[tiab] OR mortality[MeSH] OR mortalities[tiab] OR fistula[tiab] OR "intraoperative complications"[MeSH] OR "intraoperative complication"[tiab] OR "intra-operative complication"[tiab] OR "intraoperative complications"[tiab] OR "intra-operative complications"[tiab] OR "postoperative complications"[MeSH] OR "postoperative complication"[tiab] OR "post-operative complication"[tiab] OR "postoperative complications"[tiab] OR "post-operative complications"[tiab]	2,585,133
#11	Non-targeted publication types	"Case Reports"[ptyp] OR "Comment"[ptyp] OR "Editorial" [ptyp] OR "Letter"[ptyp] OR "Retracted Publication"[ptyp] OR "Duplicate Publication"[ptyp] OR "Expression of concern"[ptyp] OR Editorial[tw] OR "case report"[tw] OR "case study"[tw] OR "expression of concern"[tw]	3,753,913
#12	Last 10 years	2009[pdat]:2019[pdat]	11,111,880
#13	Medtronic stapling device or generic + manufacturer	(#4 OR #7) AND #5	318
#14	Competitor stapling device or generic + manufacturer	(#3 OR #8) AND #5	165
#15	Both Medtronic + competitor	#13 AND #14	32
#16	All relevant stapling technologies	#13 OR #14	451

11. References

- 1 Oberkofler CE, Nocito A: Surgical staplers, Atlas of upper gastrointestinal and hepato-pancreato-biliary surgery, 2nd edition. Edited by Clavien P-A, Sarr MG, Fong Y, Miazaki M. Berlin, Springer, 2016, pp 25-28.
- 2 Gaidry AD, Tremblay L, Nakayama D, Ignacio RC, Jr. The history of surgical staplers: a combination of Hungarian, Russian, and American innovation. *Am Surg*. 2019; 85: 563-566. [PMID:31267894](#).
- 3 Hasegawa S, Nakayama S, Hida K, Kawada K, Sakai Y. Effect of Tri-Staple technology and slow firing on secure stapling using an endoscopic linear stapler. *Dig Surg*. 2015; 32: 353-360. doi:10.1159/000437216. [PMID:26228297](#).
- 4 Okami J, Tokunaga T, Kanou T, et al. Randomized study comparing equal Height staples with graduated height staples in bronchial closure. *Ann Thorac Surg*. 2017; 104: 1012-1019. doi:10.1016/j.athoracsur.2017.02.070. [PMID:28551048](#).
- 5 Rivadeneira DE, Verdeja JC, Sonoda T. Improved access and visibility during stapling of the ultra-low rectum: a comparative human cadaver study between two curved staplers. *Ann Surg Innov Res*. 2012; 6: 11. doi:10.1186/1750-1164-6-11. [PMID:23148602](#).
- 6 Subotic D, Hojski A, Wiese M, Lardinois D. Use of staplers and adverse events in thoracic surgery. *J Thorac Dis*. 2019; 11: S1216-S1221. doi:10.21037/jtd.2019.03.13. [PMID:31245090](#).
- 7 Akil A, Semik M, Freermann S, et al. Use of a powered stapling system for minimally invasive lung volume reduction surgery: results of a prospective double-blind single-center randomized trial. *Thorac Cardiovasc Surg*. 2019; 67: 216-221. doi:10.1055/s-0037-1606313. [PMID:28905341](#).
- 8 Layani L, Gautam S. Bleeding in stapling. In: IFSO 2017 22(nd) World Congress. *Obes Surg*. 2017; 27: 1006. doi:10.1007/s11695-017-2774-7. [PMID:28646415](#).
- 9 Satoh Y, Matsui Y, Ogawa F, et al. Clinical report on a computer-controlled hand-actuated stapling system for general lung surgery: the first application in Japan. *Gen Thorac Cardiovasc Surg*. 2009; 57: 402-405. doi:10.1007/s11748-009-0407-3. [PMID:19779787](#).
- 10 Wang H, Lu J, Feng J, Wang Z. Staple line oversewing during laparoscopic sleeve gastrectomy. *Ann R Coll Surg Engl*. 2017; 99: 509-514. doi:10.1308/rcsann.2017.0074. [PMID:28853595](#).
- 11 Gagner M, Kemmeter P. Comparison of laparoscopic sleeve gastrectomy leak rates in five staple-line reinforcement options: a systematic review. *Surg Endosc*. 2020; 34: 396-407. doi:10.1007/s00464-019-06782-2. [PMID:30993513](#).
- 12 Hong KP, Kim DK, Kang KH. Staple line coverage with a polyglycolic acid patch and fibrin glue without pleural abrasion after thoracoscopic bullectomy for primary spontaneous pneumothorax. *Korean J Thorac Cardiovasc Surg*. 2016; 49: 85-91. doi:10.5090/kjtcs.2016.49.2.85. [PMID:27066431](#).
- 13 Ho YH, Ashour MA. Techniques for colorectal anastomosis. *World J Gastroenterol*. 2010; 16: 1610-1621. doi:10.3748/wjg.v16.i13.1610. [PMID:20355239](#).
- 14 Zafar SN, Felton J, Miller K, Wise ES, Kligman M. Staple line treatment and bleeding after laparoscopic sleeve gastrectomy. *JLS*. 2018; 22: e2018.00056. doi:10.4293/JLS.2018.00056. [PMID:30607100](#).
- 15 Silecchia G, Iossa A. Complications of staple line and anastomoses following laparoscopic bariatric surgery. *Ann Gastroenterol*. 2018; 31: 56-64. doi:10.20524/aog.2017.0201. [PMID:29333067](#).
- 16 Ito H, Nakayama H. The efficiency and safety of variable-height staple technology in pulmonary resections. *Clin Surg*. 2018; 3: 2091.

- 17 Pan H, Chang R, Zhou Y, et al. Risk factors associated with prolonged air leak after video-assisted thoracic surgery pulmonary resection: a predictive model and meta-analysis. *Ann Transl Med*. 2019; 7: 103. doi:10.21037/atm.2019.02.17. [PMID:31019953](#).
- 18 Yamamoto S, Kanai T, Osumi K, et al. Anastomotic leakage using linear stapling device with pre-attached bioabsorbable polyglycolic acid felt after laparoscopic anterior resection. *Anticancer Res*. 2017; 37: 7083-7086. doi:10.21873/anticancer.12181. [PMID:29187499](#).
- 19 Kollar D, Huszar T, Poharnok Z, Cselovszky E, Olah A. A review of techniques for closure of the pancreatic remnant following distal pancreatectomy. *Dig Surg*. 2016; 33: 320-328. doi:10.1159/000445017. [PMID:27215609](#).
- 20 Ecker BL, McMillan MT, Allegrini V, et al. Risk factors and mitigation strategies for pancreatic fistula after distal pancreatectomy: analysis of 2026 resections from the International, Multi-institutional Distal Pancreatectomy Study Group. *Ann Surg*. 2019; 269: 143-149. doi:10.1097/SLA.0000000000002491. [PMID:28857813](#).
- 21 Gumbs AA, Gayet B, Gagner M. Laparoscopic liver resection: when to use the laparoscopic stapler device. *HPB (Oxford)*. 2008; 10: 296-303. doi:10.1080/13651820802166773. [PMID:18773113](#).
- 22 Scuderi V, Troisi RI. Tissue management with tri-staple technology in major and minor laparoscopic liver resections. *Int Surg*. 2014; 99: 606-611. doi:10.9738/INTSURG-D-13-00101.1. [PMID:25216429](#).
- 23 Turrentine FE, Denlinger CE, Simpson VB, et al. Morbidity, mortality, cost, and survival estimates of gastrointestinal anastomotic leaks. *J Am Coll Surg*. 2015; 220: 195-206. doi:10.1016/j.jamcollsurg.2014.11.002. [PMID:25592468](#).
- 24 Acquafresca PA, Palermo M, Rogula T, Duza GE, Serra E. Early surgical complications after gastric by-pass: a literature review. *Arq Bras Cir Dig*. 2015; 28: 74-80. doi:10.1590/S0102-67202015000100019. [PMID:25861076](#).
- 25 Ghosh SK, Roy S, Daskiran M, et al. The clinical and economic burden of significant bleeding during lung resection surgery: A retrospective matched cohort analysis of real-world data. *J Med Econ*. 2016; 19: 1081-1086. doi:10.1080/13696998.2016.1199431. [PMID:27266753](#).
- 26 ECRI Institute. Misuse of surgical staples. Hazard #1 - 2020 top 10 health technology hazards. *Health Devices*. 2019.
- 27 Zogg CK, Ottesen TD, Kebaish KJ, et al. The cost of complications following major resection of malignant neoplasia. *J Gastrointest Surg*. 2018; 22: 1976-1986. doi:10.1007/s11605-018-3850-6. [PMID:29946953](#).
- 28 Geller AD, Zheng H, Mathisen DJ, Wright CD, Lanuti M. Relative incremental costs of complications of lobectomy for stage I non-small cell lung cancer. *J Thorac Cardiovasc Surg*. 2018; 155: 1804-1811. doi:10.1016/j.jtcvs.2017.11.025. [PMID:29254638](#).
- 29 Ahmed A, Adamo M, Srinivasan B: The real costs of treating early post-operative leaks following sleeve gastrectomy procedures. In: 20th IFSO World Congress, 20th IFSO World Congress. Vienna, Austria, Obesity Surgery, 2015, pp S45, doi:10.1007/s11695-015-1750-3.
- 30 Gayrel X, Loureiro M, Skalli EM, et al. Clinical and economic evaluation of absorbable staple line buttressing in sleeve gastrectomy in high-risk patients. *Obes Surg*. 2016; 26: 1710-1716. doi:10.1007/s11695-015-1991-1. [PMID:26677058](#).
- 31 Nedelcu M, Manos T, Gagner M, et al. Cost analysis of leak after sleeve gastrectomy. *Surg Endosc*. 2017; 31: 4446-4450. doi:10.1007/s00464-017-5495-z. [PMID:28378080](#).
- 32 Barski K, Binda A, Kudlicka E, Jaworski P, Tarnowski W. Gastric wall thickness and stapling in laparoscopic sleeve gastrectomy - a literature review. *Wideochir Inne Tech Maloinwazyjne*. 2018; 13: 122-127. doi:10.5114/wiitm.2018.73362. [PMID:29643968](#).
- 33 Huang R, Gagner M. A thickness calibration device is needed to determine staple height and avoid leaks in laparoscopic sleeve gastrectomy. *Obes Surg*. 2015; 25: 2360-2367. doi:10.1007/s11695-015-1705-8. [PMID:26024735](#).

- 34 Chekan E, Whelan RL. Surgical stapling device-tissue interactions: what surgeons need to know to improve patient outcomes. *Med Devices (Auckl)*. 2014; 7: 305-18. doi:10.2147/MDER.S67338. [PMID:25246812](#).
- 35 van Vugt JL, Tegels JJ, Derikx JP, Visschers RG, Stoot JH. First experiences with the Radial Reload with Tri-staple technology in low rectal surgery. *Int J Surg*. 2015; 14: 23-27. doi:10.1016/j.ijssu.2014.12.027. [PMID:25576759](#).
- 36 Adil MT, Aminian A, Bhasker AG, et al. Perioperative practices concerning sleeve gastrectomy - a survey of 863 surgeons with a cumulative experience of 520,230 procedures. *Obes Surg*. 2020; 30: 483-492. doi:10.1007/s11695-019-04195-7. [PMID:31677017](#).
- 37 Rosenthal RJ, International Sleeve Gastrectomy Expert P, Diaz AA, et al. International sleeve gastrectomy expert panel consensus statement: best practice guidelines based on experience of >12,000 cases. *Surg Obes Relat Dis*. 2012; 8: 8-19. doi:10.1016/j.soard.2011.10.019. [PMID:22248433](#).
- 38 Derici S, Atila K, Bora S. The effect of the cartridge used in laparoscopic sleeve gastrectomy on the development of a staple-line leak. *Am Surg*. 2018; 84: 1499-1503. [PMID:30268184](#).
- 39 Nienhuijs SW, Kaymak U, Korsten E, Buise MP. Influence of intraoperative hypotension on leaks after sleeve gastrectomy. *Surg Obes Relat Dis*. 2016; 12: 535-539. doi:10.1016/j.soard.2015.08.506. [PMID:26656668](#).
- 40 Ruiz-Tovar J, Zubiaga L, Munoz JL, Llaveró C. Incidence of postoperative nausea and vomiting after laparoscopic sleeve gastrectomy with staple line reinforcement with oversewing and staple line inversion vs buttressing material: A randomized clinical trial. *Int J Surg*. 2018; 59: 75-79. doi:10.1016/j.ijssu.2018.09.010. [PMID:30292000](#).
- 41 Shigeeda W, Deguchi H, Tomoyasu M, et al. The utility of the stapler with PGA sheet for pulmonary wedge resection: a propensity score-matched analysis. *J Thorac Dis*. 2019; 11: 1546-1553. doi:10.21037/jtd.2019.03.05. [PMID:31179098](#).
- 42 Deguchi H, Tomoyasu M, Shigeeda W, et al. Reduction of air leakage using linear staple device with bioabsorbable polyglycolic acid felt for pulmonary lobectomy. *Gen Thorac Cardiovasc Surg*. 2019; 10.1007/s11748-019-01207-2. doi:10.1007/s11748-019-01207-2. [PMID:31541348](#).
- 43 Man-I M, Suda K, Kikuchi K, et al. Totally intracorporeal delta-shaped B-I anastomosis following laparoscopic distal gastrectomy using the Tri-Staple reloads on the manual Ultra handle: a prospective cohort study with historical controls. *Surg Endosc*. 2015; 29: 3304-3312. doi:10.1007/s00464-015-4085-1. [PMID:25732753](#).
- 44 Nagahisa Y, Morikawa A, Kato T, et al. Feasibility of Endo GIA Reinforced Reload with Tri-Staple technology for delta-shaped anastomosis. *Asian J Surg*. 2018; 41: 448-453. doi:10.1016/j.asjsur.2017.04.002. [PMID:28689730](#).
- 45 Watanabe J, Ota M, Suwa Y, et al. Single-incision laparoscopic anterior resection using a curved stapler. *Dis Colon Rectum*. 2016; 59: 1105-1109. doi:10.1097/DCR.0000000000000687. [PMID:27749488](#).
- 46 Hayashibe A, Ogino N. Clinical study for pancreatic fistula after distal pancreatectomy with mesh reinforcement. *Asian J Surg*. 2018; 41: 236-240. doi:10.1016/j.asjsur.2016.11.001. [PMID:27964997](#).
- 47 Karabacak I, Satoi S, Yanagimoto H, et al. Comparison of surgical outcomes of three different stump closure techniques during distal pancreatectomy. *Pancreatol*. 2017; 17: 497-503. doi:10.1016/j.pan.2017.04.005. [PMID:28411019](#).
- 48 Kawai M, Hirono S, Okada KI, et al. Reinforced staplers for distal pancreatectomy. *Langenbecks Arch Surg*. 2017; 402: 1197-1204. doi:10.1007/s00423-017-1634-1. [PMID:29103084](#).
- 49 Kawaida H, Kono H, Watanabe M, et al. Risk factors of postoperative pancreatic fistula after distal pancreatectomy using a triple-row stapler. *Surg Today*. 2018; 48: 95-100. doi:10.1007/s00595-017-1554-2. [PMID:28600634](#).

- 50 Kondo N, Uemura K, Nakagawa N, et al. A multicenter, randomized, controlled trial comparing reinforced staplers with bare staplers during distal pancreatectomy (HiSCO-07 Trial). *Ann Surg Oncol*. 2019; 26: 1519-1527. doi:10.1245/s10434-019-07222-0. [PMID:30783854](#).
- 51 Yamashita YI, Tsujita E, Chikamoto A, et al. Linear stapling device with pre-attached bioabsorbable polyglycolic acid felt reduces postoperative pancreatic fistula after distal pancreatectomy. *Anticancer Res*. 2017; 37: 1865-1868. doi:10.21873/anticancer.11523. [PMID:28373453](#).
- 52 Pulvirenti A, Landoni L, Borin A, et al. Reinforced stapler versus ultrasonic dissector for pancreatic transection and stump closure for distal pancreatectomy: A propensity matched analysis. *Surgery*. 2019; 166: 271-276. doi:10.1016/j.surg.2019.02.016. [PMID:30975498](#).
- 53 Sheppard C. Laparoscopic sleeve gastrectomy with Tri-Staple™ reinforcement for severe obesity. *Surgery: Current Research*. 2013; 03: 144. doi:10.4172/2161-1076.1000144.
- 54 Cesana G, Cioffi S, Giorgi R, et al. Proximal leakage after laparoscopic sleeve gastrectomy: an analysis of preoperative and operative predictors on 1738 consecutive procedures. *Obes Surg*. 2018; 28: 627-635. doi:10.1007/s11695-017-2907-z. [PMID:28840492](#).
- 55 Debs T, Petrucciani N, Kassir R, et al. Complications after laparoscopic sleeve gastrectomy: can we approach a 0% rate using the largest staple height with reinforcement all along the staple line? Short-term results and technical considerations. *Surg Obes Relat Dis*. 2018; 14: 1804-1810. doi:10.1016/j.soard.2018.08.028. [PMID:30316829](#).
- 56 Bayrak M, Altintas Y. Comparing reinforcement options for the staple line of laparoscopic sleeve gastrectomy. *J Coll Physicians Surg Pak*. 2019; 29: 661-664. doi:10.29271/jcpsp.2019.07.661. [PMID:31253220](#).
- 57 Demmy TL, Mayfield WR. Anvil extension technology in thoracic surgery. *Ann Thorac Surg*. 2012; 93: 1280-1284. doi:10.1016/j.athoracsur.2011.11.030. [PMID:22450075](#).
- 58 Thomas M. Uniportal video-assisted thoracoscopic surgery left upper lobe trisegmentectomy using flexible tip 3D video scope. *J Thorac Dis*. 2017; 9: 3285-3287. doi:10.21037/jtd.2017.07.61. [PMID:29221310](#).
- 59 Yamane H, Yoshida S, Yoshida T, et al. Laparoscopic anatomical segment 3 segmentectomy for hepatocellular carcinoma accompanied by hypoplasia of the right hepatic lobe. *J Surg Case Rep*. 2019; 2019: rjz213. doi:10.1093/jscr/rjz213. [PMID:31308931](#).
- 60 Panovski MJ, Fildishevski IV, Ognjenovic LL, Dejanova-Ilijevska VI. New surgical technologies could facilitate surgical hemostasis in hemophilic patients. *Open Access Maced J Med Sci*. 2017; 5: 295-298. doi:10.3889/oamjms.2017.062. [PMID:28698745](#).
- 61 Blanc P, Breton C, Kassir R, Lointier P: Laparoscopic Roux-en-Y gastric bypass with 30 mm linear cutter technique gastrojejunal anastomosis, Abstracts from the 19th World Congress of the International Federation for the Surgery of Obesity & Metabolic Disorders (IFSO). Montreal, Canada, Obesity Surgery, 2014, pp 1136-1378, doi:10.1007/s11695-014-1292-0.
- 62 Sano A, Yotsumoto T. Single-port thoracoscopic lung wedge resection using the Endo GIA Radial Reload. *Surg Today*. 2018; 48: 248-251. doi:10.1007/s00595-017-1572-0. [PMID:28744668](#).
- 63 Ema T. The experience of using Endo GIA Radial Reload with Tri-Staple Technology for various lung surgery. *J Thorac Dis*. 2014; 6: 1482-1484. doi:10.3978/j.issn.2072-1439.2014.09.06. [PMID:25364526](#).
- 64 Nakamura M, Wakabayashi G, Miyasaka Y, et al. Multicenter comparative study of laparoscopic and open distal pancreatectomy using propensity score-matching. *J Hepatobiliary Pancreat Sci*. 2015; 22: 731-736. doi:10.1002/jhbp.268. [PMID:26087943](#).
- 65 Peng YP, Zhu XL, Yin LD, et al. Risk factors of postoperative pancreatic fistula in patients after distal pancreatectomy: a systematic review and meta-analysis. *Sci Rep*. 2017; 7: 185. doi:10.1038/s41598-017-00311-8. [PMID:28298641](#).

- 66 Probst P, Huttner FJ, Klaiber U, et al. Stapler versus scalpel resection followed by hand-sewn closure of the pancreatic remnant for distal pancreatectomy. *Cochrane Database Syst Rev*. 2015; 10.1002/14651858.CD008688.pub2: CD008688. doi:10.1002/14651858.CD008688.pub2. [PMID:26544925](#).
- 67 Miller DL, Roy S, Kassis ES, et al. Impact of powered and tissue-specific endoscopic stapling technology on clinical and economic outcomes of video-assisted thoracic surgery lobectomy procedures: a retrospective, observational study. *Adv Ther*. 2018; 35: 707-723. doi:10.1007/s12325-018-0679-z. [PMID:29663180](#).
- 68 Roy S, Yoo A, Yadalam S, et al. Comparison of economic and clinical outcomes between patients undergoing laparoscopic bariatric surgery with powered versus manual endoscopic surgical staplers. *J Med Econ*. 2017; 20: 423-433. doi:10.1080/13696998.2017.1296453. [PMID:28270023](#).
- 69 Matsuzawa F, Homma S, Yoshida T, et al. Serosal laceration during firing of powered linear stapler Is a predictor of staple malformation. *Surg Innov*. 2017; 24: 590-597. doi:10.1177/1553350617733350. [PMID:28962536](#).
- 70 Frering V, Blanchet MC, Gignoux B: Using Signia stapling system for sleeve gastrectomy, IFSO 2017 22(nd) World Congress, Obes Surg, 2017, pp 1051, doi:10.1007/s11695-017-2774-7.
- 71 Ramirez Almaral JC, Ramirez Castro C: Performance of the electronic and smart staplers in laparoscopic sleeve gastrectomy. 300 cases without complications, 24(th) IFSO World Congress. Madrid, Spain, Obes Surg, 2019, pp 529, doi:10.1007/s11695-019-04101-1.
- 72 Al-Musawi M, Fackelmayer O, Fox CJ. Sleeve fistulectomy: a novel hybrid technique to manage the degenerative arteriovenous fistula. *Ann Vasc Surg*. 2020; 63: 450-453. doi:10.1016/j.avsg.2019.10.064. [PMID:31734183](#).
- 73 Yagi Y, Kodama K, Momozane T, et al. Surgery to avoid fatal complications and secure radicality after definitive chemoradiotherapy for clinical T4N2M0 stage IIIB non-small cell lung cancer: a case report. *Surg Case Rep*. 2020; 6: 16. doi:10.1186/s40792-019-0768-5. [PMID:31933045](#).
- 74 Contini E, Whiffen J, Bronson D. Comparison of endostapler performance in challenging tissue applications. *Surg Obes Relat Dis*. 2013; 9: 417-421. doi:10.1016/j.soard.2012.10.009. [PMID:23260804](#).
- 75 Bransen J, Gilissen LP, van Rutte PW, Nienhuijs SW. Costs of leaks and bleeding after sleeve gastrectomies. *Obes Surg*. 2015; 25: 1767-1771. doi:10.1007/s11695-015-1584-z. [PMID:25636733](#).
- 76 Carter JE. Suture? Staple? Electrosurgery? How to decide what is best for you. *JSLs*. 1997; 1: 171-174. [PMID:9876668](#).
- 77 Malapert G, Hanna HA, Pages PB, Bernard A. Surgical sealant for the prevention of prolonged air leak after lung resection: meta-analysis. *Ann Thorac Surg*. 2010; 90: 1779-1785. doi:10.1016/j.athoracsur.2010.07.033. [PMID:21095309](#).
- 78 Baker RS, Foote J, Kemmeter P, et al. The science of stapling and leaks. *Obes Surg*. 2004; 14: 1290-1298. doi:10.1381/0960892042583888. [PMID:15603641](#).
- 79 Kim H, Jang JY, Son D, et al. Optimal stapler cartridge selection according to the thickness of the pancreas in distal pancreatectomy. *Medicine (Baltimore)*. 2016; 95: e4441. doi:10.1097/MD.0000000000004441. [PMID:27583852](#).
- 80 Chekan EG, Cummings JF, Mabe I, Hunter S, Clymer JW. Thickness of cadaveric human lung tissue. *Surg Technol Int*. 2016; 29: 207-213. [PMID:27466868](#).
- 81 Meydan C, Raziell A, Sakran N, Gottfried V, Goitein D. Single anastomosis gastric bypass-comparative short-term outcome study of conversional and primary procedures. *Obes Surg*. 2017; 27: 432-438. doi:10.1007/s11695-016-2336-4. [PMID:27562250](#).

- 82 Heneghan HM, Kerrigan DD. Laparoscopic SADI-S as a salvage procedure for failed gastric bypass and sleeve gastrectomy: How I do it. *Surg Obes Relat Dis*. 2018; 14: 715-718. doi:10.1016/j.soard.2018.01.043. [PMID:29576484](#).
- 83 Jung JP, Zenati MS, Dhir M, et al. Use of video review to investigate technical factors that may be associated with delayed gastric emptying after pancreaticoduodenectomy. *JAMA Surg*. 2018; 153: 918-927. doi:10.1001/jamasurg.2018.2089. [PMID:29998288](#).
- 84 Costi R, Castro Ruiz C, Zarzavadjian le Bian A, et al. Spleen hydatidosis treated by hemi-splenectomy: A low-morbidity, cost-effective management by a recently improved surgical technique. *Int J Surg*. 2015; 20: 41-5. doi:10.1016/j.ijsu.2015.06.018. [PMID:26074292](#).
- 85 Odabasi M, Muftuoglu MA, Ozkan E, et al. Use of stapling devices for safe cholecystectomy in acute cholecystitis. *Int Surg*. 2014; 99: 571-576. doi:10.9738/INTSURG-D-14-00035.1. [PMID:25216423](#).
- 86 Obrist NM, Tschuor C, Breitenstein S, Vuille-Dit-Bille RN, Soll C. Appendectomy in Switzerland: how is it done? *Updates Surg*. 2019; 71: 375-380. doi:10.1007/s13304-019-00654-z. [PMID:30982171](#).
- 87 Hood RM, Kirksey TD, Calhoon JH, Arnold HS, Tate RS. The use of automatic stapling devices in pulmonary resection. *Ann Thorac Surg*. 1973; 16: 85-98. doi:10.1016/s0003-4975(10)65815-8. [PMID:4721195](#).
- 88 Fanning J, Hilgers RD, Palabrica C. Surgical stapling technique for radical hysterectomy. *Gynecol Oncol*. 1994; 55: 179-184. doi:10.1006/gyno.1994.1274. [PMID:7959281](#).
- 89 Yoong W, Neophytou C, de Silva L, Adeyemo A, Lodhi W. Novel laparoscopic cornual resection of interstitial pregnancy using the Endo GIA Universal Stapler (Medtronic): A series of 12 cases. *Aust N Z J Obstet Gynaecol*. 2020; 60: 130-134. doi:10.1111/ajo.13082. [PMID:31667826](#).
- 90 Shogan BD, Carlisle EM, Alverdy JC, Umanskiy K. Do we really know why colorectal anastomoses leak? *J Gastrointest Surg*. 2013; 17: 1698-707. doi:10.1007/s11605-013-2227-0. [PMID:23690209](#).
- 91 Ghosh SK, Roy S, Chekan E, Fegelman EJ. A narrative of intraoperative staple line leaks and bleeds during bariatric surgery. *Obes Surg*. 2016; 26: 1601-1606. doi:10.1007/s11695-016-2177-1. [PMID:27094877](#).
- 92 Walsh C, Karmali S. Endoscopic management of bariatric complications: A review and update. *World J Gastrointest Endosc*. 2015; 7: 518-523. doi:10.4253/wjge.v7.i5.518. [PMID:25992190](#).
- 93 Hammond J, Lim S, Wan Y, Gao X, Patkar A. The burden of gastrointestinal anastomotic leaks: an evaluation of clinical and economic outcomes. *J Gastrointest Surg*. 2014; 18: 1176-1185. doi:10.1007/s11605-014-2506-4. [PMID:24671472](#).
- 94 Bronstein ME, Koo DC, Weigel TL. Management of air leaks post-surgical lung resection. *Ann Transl Med*. 2019; 7: 361. doi:10.21037/atm.2019.04.30. [PMID:31516907](#).
- 95 Mueller MR, Marzluf BA. The anticipation and management of air leaks and residual spaces post lung resection. *J Thorac Dis*. 2014; 6: 271-284. doi:10.3978/j.issn.2072-1439.2013.11.29. [PMID:24624291](#).
- 96 Kwazneski D, 2nd, Six C, Stahlfeld K. The unacknowledged incidence of laparoscopic stapler malfunction. *Surg Endosc*. 2013; 27: 86-9. doi:10.1007/s00464-012-2417-y. [PMID:22806510](#).
- 97 Shikora SA, Mahoney CB. Clinical benefit of gastric staple line reinforcement (SLR) in gastrointestinal surgery: a meta-analysis. *Obes Surg*. 2015; 25: 1133-1141. doi:10.1007/s11695-015-1703-x. [PMID:25968078](#).
- 98 Balkarov AA, Ponomarenko AA, Alekseev MV, Rybakov EG, Frolov SA. [Reinforcement of staple line of colorectal anastomosis for leakage prevention: a systematic review and metaanalysis]. *Khirurgija (Mosk)*. 2019; 10.17116/hirurgia201908153: 53-58. doi:10.17116/hirurgia201908153. [PMID:31464275](#).
- 99 Corso P: Introduction to economic evaluation [part 1 of 5-part educational series], Centers for Disease Control and Prevention, Division for Heart Disease and Stroke Prevention, 2016,

- 100 Suh S, Helm M, Kindel TL, et al. The impact of nausea on post-operative outcomes in bariatric surgery patients. *Surg Endosc*. 2019; 10.1007/s00464-019-07058-5. doi:10.1007/s00464-019-07058-5. [PMID:31388805](#).
- 101 Al-Kurd A, Grinbaum R, Abubeih A, et al. Not all leaks are created equal: a comparison between leaks after sleeve gastrectomy and Roux-En-Y gastric bypass. *Obes Surg*. 2018; 28: 3775-3782. doi:10.1007/s11695-018-3409-3. [PMID:30022425](#).
- 102 Zafar SN, Miller K, Felton J, Wise ES, Kligman M. Postoperative bleeding after laparoscopic Roux en Y gastric bypass: predictors and consequences. *Surg Endosc*. 2019; 33: 272-280. doi:10.1007/s00464-018-6365-z. [PMID:30232617](#).
- 103 Bassi C, Dervenis C, Butturini G, et al. Postoperative pancreatic fistula: an international study group (ISGPF) definition. *Surgery*. 2005; 138: 8-13. doi:10.1016/j.surg.2005.05.001. [PMID:16003309](#).
- 104 Williamsson C, Ansari D, Andersson R, Tingstedt B. Postoperative pancreatic fistula-impact on outcome, hospital cost and effects of centralization. *HPB (Oxford)*. 2017; 19: 436-442. doi:10.1016/j.hpb.2017.01.004. [PMID:28161218](#).
- 105 Wan X, Wang W, Liu J, Tong T. Estimating the sample mean and standard deviation from the sample size, median, range and/or interquartile range. *BMC Med Res Methodol*. 2014; 14: 135. doi:10.1186/1471-2288-14-135. [PMID:25524443](#).
- 106 Shimizu N, Tanaka Y, Okamoto T, et al. How to prevent adverse events of vascular stapling in thoracic surgery: recommendations based on a clinical and experimental study. *J Thorac Dis*. 2018; 10: 6466-6471. doi:10.21037/jtd.2018.11.14. [PMID:30746189](#).
- 107 Ito M, Sugito M, Kobayashi A, et al. Relationship between multiple numbers of stapler firings during rectal division and anastomotic leakage after laparoscopic rectal resection. *Int J Colorectal Dis*. 2008; 23: 703-707. doi:10.1007/s00384-008-0470-8. [PMID:18379795](#).
- 108 Eschbach M, Sindberg GM, Godek ML, et al. Micro-CT imaging as a method for comparing perfusion in graduated-height and single-height surgical staple lines. *Med Devices (Auckl)*. 2018; 11: 267-273. doi:10.2147/MDER.S171357. [PMID:30147383](#).
- 109 Dayal S, Battersby N, Cecil T. Evolution of surgical treatment for rectal cancer: a review. *J Gastrointest Surg*. 2017; 21: 1166-1173. doi:10.1007/s11605-017-3427-9. [PMID:28444558](#).
- 110 Hirano Y, Hattori M, Douden K, Hashizume Y. A new laparoscopic rectal transection method via umbilical incision using Endo GIA Radial Reload. *Indian J Surg*. 2015; 77: 1466-1468. doi:10.1007/s12262-015-1223-x. [PMID:27011602](#).
- 111 Kimura M, Mitsui A, Kuwabara Y. Creation of the ideal gastric tube: Comparison of three methods: A prospective cohort study. *Ann Med Surg (Lond)*. 2016; 6: 42-45. doi:10.1016/j.amsu.2016.01.080. [PMID:26909152](#).
- 112 Scott-Conner CEH, Chassin JL: Surgical Stapling: Principles and Precautions, Chassin's operative strategy in general surgery. Edited by Scott-Conner CEH. New York, Springer Science+Business Media, 2014, pp 39-44.
- 113 Naito M, Sato T, Nakamura T, et al. Secure overlap stapling using a linear stapler with bioabsorbable polyglycolic acid felt. *Asian J Endosc Surg*. 2017; 10: 308-312. doi:10.1111/ases.12364. [PMID:28224709](#).
- 114 Contini E, Godek ML, Whiffen JM, Bronson DG. Ex vivo pneumostasis evaluation of a variable-height staple design. *Innovations (Phila)*. 2013; 8: 284-288. doi:10.1097/IMI.0b013e3182a6912a. [PMID:24145973](#).
- 115 Yehoshua RT, Eidelman LA, Stein M, et al. Laparoscopic sleeve gastrectomy--volume and pressure assessment. *Obes Surg*. 2008; 18: 1083-1088. doi:10.1007/s11695-008-9576-x. [PMID:18535864](#).
- 116 Timucin Aydin M, Aras O, Karip B, Memisoglu K. Staple line reinforcement methods in laparoscopic sleeve gastrectomy: comparison of burst pressures and leaks. *JLS*. 2015; 19: doi:10.4293/JLS.2015.00040. [PMID:26175554](#).

- 117 Zakkar M, Kanagasabay R, Hunt I. No evidence that manual closure of the bronchial stump has a lower failure rate than mechanical stapler closure following anatomical lung resection. *Interact Cardiovasc Thorac Surg*. 2014; 18: 488-493. doi:10.1093/icvts/ivt502. [PMID:24351508](#).
- 118 He HH, He JX, Hao ZX, Wang W, He JX. Association between different sequences of vessel ligation during video-assisted thoracoscopic lobectomy and survival in patients with non-small cell lung cancer. *J Thorac Dis*. 2019; 11: 686-693. doi:10.21037/jtd.2019.02.69. [PMID:31019755](#).
- 119 Wolfe BM, Kvach E, Eckel RH. Treatment of obesity: weight loss and bariatric surgery. *Circ Res*. 2016; 118: 1844-1855. doi:10.1161/CIRCRESAHA.116.307591. [PMID:27230645](#).
- 120 Buchwald H, Buchwald JN. Metabolic (bariatric and nonbariatric) surgery for Type 2 Diabetes: a personal perspective review. *Diabetes Care*. 2019; 42: 331-340. doi:10.2337/dc17-2654. [PMID:30665965](#).
- 121 Oh Y, Kim MS, Lee YT, et al. Laparoscopic total gastrectomy as a valid procedure to treat gastric cancer option both in early and advanced stage: A systematic review and meta-analysis. *Eur J Surg Oncol*. 2020; 46: 33-43. doi:10.1016/j.ejso.2019.08.018. [PMID:31477462](#).
- 122 Kodama S, Fujihara K, Horikawa C, et al. Network meta-analysis of the relative efficacy of bariatric surgeries for diabetes remission. *Obes Rev*. 2018; 19: 1621-1629. doi:10.1111/obr.12751. [PMID:30270528](#).
- 123 Welbourn R, Hollyman M, Kinsman R, et al. Bariatric surgery worldwide: baseline demographic description and one-year outcomes from the fourth IFSO global registry report 2018. *Obes Surg*. 2019; 29: 782-795. doi:10.1007/s11695-018-3593-1. [PMID:30421326](#).
- 124 Lee S, Davies AR, Bahal S, et al. Comparison of gastrojejunal anastomosis techniques in laparoscopic Roux-en-Y gastric bypass: gastrojejunal stricture rate and effect on subsequent weight loss. *Obes Surg*. 2014; 24: 1425-1429. doi:10.1007/s11695-014-1219-9. [PMID:24595472](#).
- 125 El Moussaoui I, Limbga A, Mehdi A. Staple line reinforcement during sleeve gastrectomy with a new type of reinforced stapler. *Minerva Chir*. 2018; 73: 127-132. doi:10.23736/S0026-4733.18.07627-7. [PMID:29397639](#).
- 126 Tanaka K, Okuda J, Yamamoto S, et al. Risk factors for anastomotic leakage after laparoscopic surgery with the double stapling technique for stage 0/I rectal carcinoma: a subgroup analysis of a multicenter, single-arm phase II trial. *Surg Today*. 2017; 47: 1215-1222. doi:10.1007/s00595-017-1496-8. [PMID:28280982](#).
- 127 Kaiser J, Hackert T, Buchler MW. Extended pancreatectomy: does it have a role in the contemporary management of pancreatic adenocarcinoma? *Dig Surg*. 2017; 34: 441-446. doi:10.1159/000478539. [PMID:28700995](#).
- 128 Umemura A, Nitta H, Takahara T, Hasegawa Y, Sasaki A. Current status of laparoscopic pancreaticoduodenectomy and pancreatectomy. *Asian J Surg*. 2018; 41: 106-114. doi:10.1016/j.asjsur.2016.09.003. [PMID:27688035](#).
- 129 Yuksel A, Bostanci EB, Colakoglu MK, et al. Pancreatic stump closure using only stapler is associated with high postoperative fistula rate after minimal invasive surgery. *Turk J Gastroenterol*. 2018; 29: 191-197. doi:10.5152/tjg.2018.17567. [PMID:29749326](#).
- 130 Seils D, Tantawy T, Peterson D, UCONN biodynamics final report #RE00022065, Biomechanical exposures related to laparoscopic stapler use. . Published 2012.
- 131 Kono E, Tada M, Kouchi M, et al. Ergonomic evaluation of a mechanical anastomotic stapler used by Japanese surgeons. *Surg Today*. 2014; 44: 1040-1047. doi:10.1007/s00595-013-0666-6. [PMID:23893125](#).
- 132 Roy S, Yadalam S, Johnston SS. Are all endoscopic surgical staplers the same? Findings from a real-world assessment in bariatric procedures. *Value in Health*. 2018; 21: S162. doi:10.1016/j.jval.2018.04.1215.

- ¹³³ Thompson SE, Young MT, Lewis MT, et al. Initial assessment of mucosal capture and leak pressure after gastrointestinal stapling in a porcine model. *Obes Surg.* 2018; 28: 3446-3453. doi:10.1007/s11695-018-3363-0. [PMID:29956107](#).
- ¹³⁴ Eckert CE, Harris JL, Wong JB, et al. Preclinical quantification of air leaks in a physiologic lung model: effects of ventilation modality and staple design. *Med Devices (Auckl)*. 2018; 11: 433-442. doi:10.2147/MDER.S184851. [PMID:30588134](#).

©2022 Medtronic. All rights reserved. Medtronic, Medtronic logo, and Further, Together are trademarks of Medtronic. ^{TM*} Third party brands are trademarks of their respective owners. All other brands are trademarks of a Medtronic company.

3/2022 - EMEA-ST-2100024-tri-staple-power-stapling-value-dossier-en-we-6887446