

# ***Nikon***

**Upright Microscope**

**ECLIPSE**

***Si***

**Instructions**

## Introduction

Thank you for purchasing a Nikon product.

This instruction manual is intended for users of the Nikon Upright Microscope ECLIPSE Si RS.

No part of this manual may be reproduced or transmitted in any form without prior written permission from Nikon.

- The contents of this manual are subject to change without notice.
  - The equipment described in this manual might differ from the actual product in its appearance.
  - Although every effort has been made to ensure the accuracy of this manual, errors or inconsistencies might remain.
  - If you notice any points that are unclear or incorrect, please contact your local Nikon representative.
  - Some of the equipment described in this manual may not be included in the set you have purchased.
  - If you intend to use any other equipment with this product, read the manual for that equipment too.
  - If the equipment is used in a manner not specified by the manufacturer, the protection provided by the equipment might be impaired.
-

## Contents

|  |           |
|--|-----------|
| Safety Precautions .....   | 3         |
| Meaning of Symbols Used on the Product.....  | 3         |
| WARNING and CAUTION Symbols.....   | 3         |
| ⚠ WARNING .....  | 4         |
| ⚠ CAUTION .....  | 6         |
| Sicherheitsvorkehrungen.....   | 7         |
| Consignes de sécurité .....  | 12        |
| Precauciones de seguridad.....   | 17        |
| Precauzioni per la sicurezza .....   | 22        |
| Veiligheidsvoorschriften.....  | 27        |
| Sikkerhedsforanstaltninger .....   | 32        |
| Precauções de segurança .....  | 37        |
| Turvatoimet.....   | 42        |
| Προφυλάξεις ασφαλείας.....   | 46        |
| Notes on Handling the Product .....  | 51        |
| <b>Chapter 1 Nomenclature of Each Part .....</b>                                   | <b>54</b> |
| <b>Chapter 2 Microscopy Techniques .....</b>                                       | <b>56</b> |
| 2.1 Bright-field Microscopy.....   | 57        |
| 2.2 Phase Contrast Microscopy .....  | 64        |
| 2.3 Simple Polarizing Microscopy .....   | 68        |
| 2.4 Diascopic Fluorescence Microscopy.....   | 72        |
| 2.5 Dark-field Microscopy.....   | 76        |
| <b>Chapter 3 Detailed Explanation.....</b>   | <b>79</b> |
| 3.1 Turning the Power On and Off .....   | 79        |
| 3.1.1 Turn On/Off the Power to the Microscope .....                                | 79        |
| 3.1.2 ECO Mode and SLEEP Mode .....  | 79        |
| 3.2 Operating Diascopic Illumination.....  | 80        |
| 3.2.1 Turning Diascopic Illumination On and Off and Adjusting the Brightness ..... | 80        |
| 3.2.2 Using Light Intensity Management .....                                       | 80        |
| 3.3 Operating the Stage Specimen Holder .....                                      | 81        |
| 3.3.1 Placing a Specimen Using the Specimen Holder .....                           | 81        |
| 3.3.2 Operating the Stage.....   | 81        |
| 3.4 Operating the Nosepiece and Objectives .....                                   | 82        |
| 3.4.1 Switching Objectives.....  | 82        |
| 3.4.2 Oil-Immersion Observation .....  | 82        |
| 3.4.3 Performing Water-Immersion Microscopy .....                                  | 83        |
| 3.5 Focusing Operations .....  | 84        |
| 3.5.1 Focusing on a Specimen .....   | 84        |
| 3.5.2 Torque Adjustment of the Coarse Focus Knob .....                             | 85        |
| 3.5.3 Replacing a Specimen Using the Stage Vertical Movement Stopper.....          | 86        |
| 3.6 Operating the Binoculars.....  | 87        |
| 3.6.1 Adjustment of Diopter .....  | 87        |
| 3.6.2 Adjusting Interpupillary Distance .....                                      | 88        |
| 3.7 Operating the Condenser.....   | 89        |
| 3.7.1 Focusing the Condenser.....  | 89        |
| 3.7.2 Centering the Condenser.....   | 89        |
| 3.8 Adjustment of Aperture Diaphragm.....  | 90        |
| 3.9 Adjustment of field diaphragm.....   | 91        |



|                  |  |            |
|------------------|--|------------|
| 3.10             | Tips for Each Microscopy Method .....                    | 92         |
| 3.10.1           | Tips for Phase Contrast Microscopy .....                 | 92         |
| 3.10.2           | Tips for Simple Polarizing Microscopy .....              | 93         |
| 3.10.3           | Tips for Diascopic Fluorescence Microscopy .....         | 94         |
| 3.10.4           | Tips for Dark-field Microscopy .....                     | 95         |
| 3.11             | Combinations of Optical Parts.....                       | 96         |
| 3.12             | Microscope Terminology .....                             | 97         |
| <b>Chapter 4</b> | <b>Assembly .....</b>                                    | <b>98</b>  |
| 4.1              | Configuration Diagrams .....                             | 98         |
| 4.2              | Assembly.....  | 99         |
| 4.2.1            | Basic Configuration (for Bright-field Microscopy) .....  | 99         |
| 4.2.2            | Configuration for Phase Contrast Microscopy .....        | 103        |
| 4.2.3            | Configuration for Simple Polarizing Microscopy .....     | 104        |
| 4.2.4            | Configuration for Diascopic Fluorescence Microscopy..... | 105        |
| 4.2.5            | Configuration for Dark-Field Microscopy .....            | 108        |
| 4.3              | Setting Up the Microscope .....                          | 109        |
| <b>Chapter 5</b> | <b>Troubleshooting .....</b>                             | <b>111</b> |
| 5.1              | Problems With the Microscope Image .....                 | 111        |
| 5.1.1            | Common Problems for Each Microscopy .....                | 111        |
| 5.1.2            | Problems in Phase Contrast Microscopy.....               | 112        |
| 5.1.3            | Problems in Simple Polarizing Microscopy.....            | 113        |
| 5.1.4            | Problems in Diascopic Fluorescence Microscopy .....      | 113        |
| 5.1.5            | Problems in Dark-field Microscopy .....                  | 114        |
| 5.2              | Problems in Operation .....                              | 115        |
| 5.3              | Electrical.....  | 116        |
| <b>Chapter 6</b> | <b>Care and Maintenance .....</b>                        | <b>117</b> |
| 6.1              | Cleaning the Lenses .....                                | 117        |
| 6.2              | Cleaning the Microscope.....                             | 117        |
| 6.3              | Disinfecting the Microscope .....                        | 117        |
| 6.4              | Storing the Microscope .....                             | 117        |
| 6.5              | Periodical Inspections (Charged).....                    | 117        |
| <b>Chapter 7</b> | <b>Specifications .....</b>                              | <b>118</b> |
| 7.1              | Microscopy (Principles).....                             | 118        |
| 7.2              | Performance Properties .....                             | 119        |
| 7.3              | Physical Properties .....                                | 120        |
| 7.4              | AC adapter .....   | 120        |
| 7.5              | Power Cord .....   | 121        |
| 7.6              | Safety standards .....                                   | 121        |
| 7.7              | External dimensions (unit: mm).....                      | 122        |

## Safety Precautions

Although this product is designed and manufactured to be completely safe during use, incorrect usage or failure to follow the safety instructions provided may cause personal injury or property damage. To ensure correct usage, read this manual carefully before using the product. Do not discard this manual and keep it handy for easy reference.

### Meaning of Symbols Used on the Product

Symbols that appear on the product indicate the need for caution at all times during use. Always refer to the instruction manual and read the relevant instructions before manipulating any part to which the symbol has been affixed.

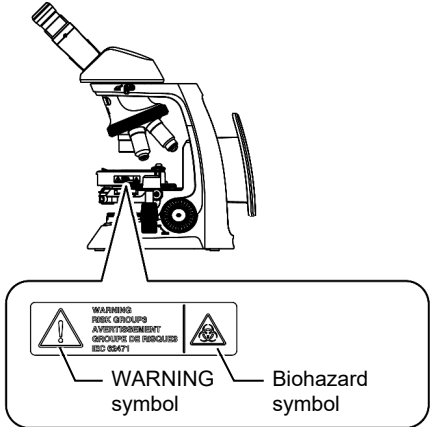

| Symbol  | Contents  |
|---|---|
|    | <p><b>Biohazard</b></p> <p>This symbol can be found on the stage of the microscope body (stage handle side), and cautions the following:</p> <ul style="list-style-type: none"> <li>• <b>WARNING:</b> The product may become biohazardous if a sample is spilled onto the product.</li> <li>• To avoid exposure to biohazard, do not touch contaminated parts with your bare hands.</li> <li>• Decontaminate the contaminated parts according to the standard procedures for your facility.</li> </ul>  |
|  | <p><b>WARNING (photobiological safety)</b></p> <p>This symbol can be found on the microscope body (stage handle side), and cautions the following:</p> <ul style="list-style-type: none"> <li>• Photobiological safety risk group classification of diascope illumination</li> <li>• Do not look into diascope illumination.</li> </ul> <p>For details, see  <b>WARNING</b>, “7. Photobiological safety” and “8. Do not look into the illumination section.”</p> |



Microscope main body (stage handle side)

### WARNING and CAUTION Symbols

Safety instructions in this manual are marked with the following symbols to highlight their importance. For your safety, always follow the instructions marked with these symbols.

| Symbol   | Contents   |
|--|--|
|  <b>WARNING</b> | Disregarding instructions marked with this symbol may lead to serious injury or death.   |
|  <b>CAUTION</b> | Disregarding instructions marked with this symbol may lead to injury or property damage. |



## WARNING

### 1. Do not disassemble.

Disassembling this product may result in electric shock or malfunction. Malfunctions and damage due to disassembly will not be warranted. Do not disassemble any part unless instructed to do so in this manual. If you experience problems with the product, contact your nearest Nikon representative.

### 2. Read the instructions thoroughly.

To ensure safety, thoroughly read this manual and the manuals for other equipment to be used with this product. In particular, be sure to follow the warnings and cautions at the beginning of the manuals.

### 3. Input voltage, AC adapter, power cord

The AC adapter for supplying power to this product can be used with 100 to 240 VAC at 50 to 60 Hz. Use only the AC adapter and power cord specified in "Chapter 7 Specifications." Use of another AC adapter or power cord may result in malfunction or fire.

- Avoid using the product in an environment where the supply voltage may fluctuate excessively.
- The AC adapter for this product is classified as Class I for electrical shock protection. Be sure to connect it to a protective earth terminal.
- If the AC adapter is covered or items are placed on the AC adapter, heat dissipation may be hindered, causing it to become abnormally hot.

### 4. Handling flammable solvents

The following flammable solvents are used with the product:

- Immersion oil (Nikon Immersion Oil for oil immersion objectives)
- Absolute alcohol (ethyl alcohol or methyl alcohol for cleaning optical parts)
- Petroleum benzine (for wiping off the immersion oil)
- Medical alcohol (for disinfecting the microscope)

Never hold a flame near these solvents. When using a solvent, ensure correct and safe use by thoroughly reading the instructions provided by the solvent manufacturer.

When using a solvent with this product, observe the following precautions:

- Keep solvents away from the product and its surroundings when plugging/unplugging the AC adapter or power cord.
- Be careful not to spill the solvents.

### 5. Hazardous samples

This microscope is mainly for use in microscopic observation of a sample such as cells and tissue affixed to a slide.

When handling a specimen, check to determine whether the specimen is hazardous. Handle hazardous specimens according to the standard procedure for your laboratory. If the specimen is of an infectious nature, wear rubber gloves to avoid infection, and be careful not to touch a specimen.

If such a sample comes in contact with the microscope, decontaminate the contaminated portion according to the standard procedure for your laboratory.

### 6. Notes on operating the sliders on the condenser part

A slider for microscopy has two set positions. It is attached to the condenser part and used for switching the observation methods or magnifications by changing the set position. The bright light might reach the eyepiece tube when you move the slider to change the set position.

Remove your eyes from the binoculars or turn off the diasopic illumination when you operate a slider.

Especially in diasopic fluorescence microscopy, the very bright illumination is used, so the intense flashes might reach the eyepiece tube when you operate the slider.



## WARNING

### 7. Photobiological safety

This product is designed and manufactured in accordance with the safety standard IEC 62471 “Photobiological safety of lamps and lamp systems.”

Illumination near the stage and light from the binocular part of the eyepiece tube or the teaching head, and light from the camera port of the trinocular eyepiece tube are classified into the following risk group. The distance (hazard distance) from the vicinity of the stage or from the binocular part of the eyepiece tube or the teaching head, or from the opening of the camera port where the risk group classification is equivalent to the exempt group that does not cause photobiological injury is as follows.

|  | Risk group classification | Hazard distance |
|--|---------------------------|-----------------|
| <b>Retinal blue light hazard</b>         | Risk group 3              | 36 m            |
| <b>Infrared radiation hazard to eyes</b> | Risk group 3              | 127 m           |

Illumination in risk group 3 can be hazardous. Pay attention to brightness adjustment by the brightness control knob and avoid looking strong light for a long time.

- The LED light source is built in at the bottom part of the microscope. Illumination light from the field lens goes through the condenser and illuminates the specimen. Do not stare at the condenser lens, specimen or periphery of the specimen, and do not look into the field lens.
- Do not look into strong light from the binocular part of the eyepiece tube or the teaching head.
- Do not remove the eyepieces from the binocular part when illumination is turned on.
- Do not look into strong light from the camera port from directly above.
- When you do not attach the camera, attach the supplied cap to the camera port.

### 8. Do not look into the illumination section.

The following warning label indicating the highest risk (Risk Group 3) to photobiological safety is affixed on the handle side of the stage to remind the user of the following precautions. (For the locations of this label, see the figure in “Chapter 1 Nomenclature of Each Part.”)

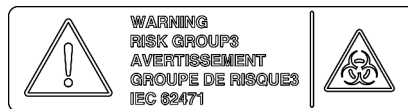

#### **WARNING (Risk Group 3)**

IR and possibly hazardous light is emitted from the camera port when the trinocular eyepiece tube is used.

Never look into the camera port.

#### **CAUTION (Risk Group 2)**

Possibly hazardous light is emitted from the condenser lens when diasopic illumination is used.

Do not stare at emitted light. It may be harmful to the eyes.

#### **NOTICE (Risk Group 1)**

Possibly hazardous light is emitted from the eyepiece lenses when diasopic illumination is used.

Avoid long-time microscopic observation with strong illumination.



## CAUTION

### 1. Assembly of the microscope

- Assemble the microscope while the AC adapter is not connected to it.
- Take care to avoid pinching your fingers and hands.

### 2. Do not wet the product or allow ingress of foreign matter.

Do not allow the product to become wet, as doing so may result in malfunction, overheating, or electric shock.

If water or other liquids are accidentally spilled onto the product, immediately unplug the power cord from the AC adapter. Then, wipe off the liquid with a dry cloth.

Ingress of foreign matter may also result in malfunction. If liquids or foreign matter gets in the product, cease use of the product, and contact your nearest Nikon representative.

### 3. Moving the product

- The microscope has carrying handholds and handles.  
There are two handholds on both sides of the base and two handles on the arm on the rear side of the microscope.  
When carrying the microscope, hold the microscope firmly by these handholds and handles.
- The storage part on the rear of the microscope is not a handle. Do not hold this part as it stores the AC adapter and power cord.
- When moving the product, do not hold by the focus knobs, eyepiece tube, and stage, etc. The parts may become detached and also result in malfunctions.

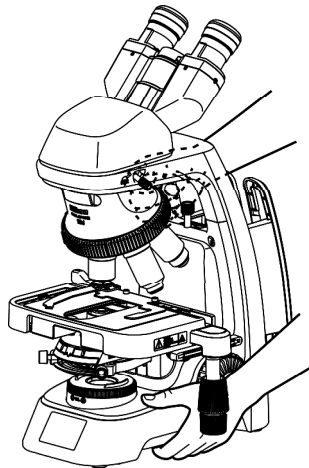
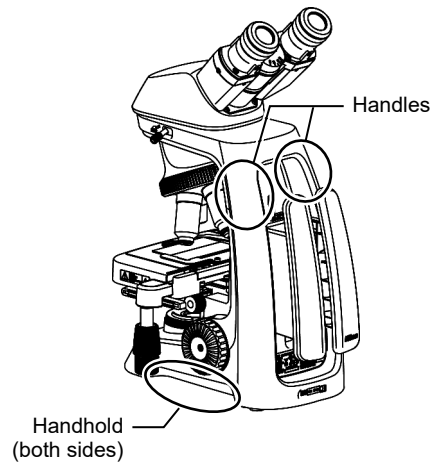

Hold a handle and a handhold.

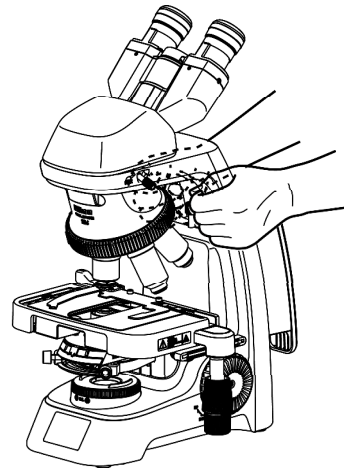

Hold the handles.

### 4. Disposal of the microscope

To avoid biohazard risks, dispose of the microscope as contaminated equipment, according to the standard procedures for your facility.





## Sicherheitsvorkehrungen

Obwohl dieses Gerät auf einen sicheren Gebrauch ausgelegt ist, kann eine falsche Verwendung oder Nichtbeachtung der Sicherheitshinweise zu Verletzungen oder Sachschäden führen. Lesen Sie vor Gebrauch des Geräts dieses Handbuch aufmerksam durch, um einen korrekten Gebrauch zu gewährleisten. Entsorgen Sie dieses Handbuch nicht. Bewahren Sie es zum einfachen Nachschlagen auf.

### Bedeutung der Symbole auf dem Gerät

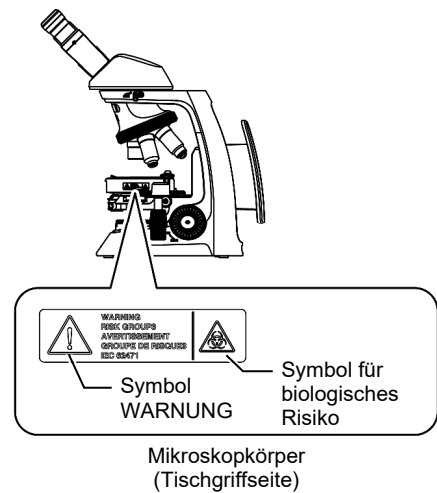

Die Symbole auf dem Gerät zeigen an, dass während des Gebrauchs stets Vorsicht geboten ist. Lesen Sie immer die entsprechenden Anweisungen in der Bedienungsanleitung, bevor Sie Arbeiten an Teilen durchführen, die mit Symbolen versehen sind.

| Symbol  | Inhalt   |
|---|--|
|    | <p><b>Biologisches Risiko</b></p> <p>Dieses Symbol befindet sich auf dem Objektstisch des Mikroskopkörpers (Tischgriffseite) und bedeutet Folgendes:</p> <ul style="list-style-type: none"> <li>• <b>WARNUNG:</b> Das Gerät kann ein biologisches Risiko darstellen, wenn eine Probe auf dem Gerät verschüttet wird.</li> <li>• Fassen Sie zum Schutz vor biologischen Risiken keine kontaminierten Stellen mit bloßen Händen an.</li> <li>• Dekontaminieren Sie kontaminierte Stellen entsprechend den Standardprozessen Ihrer Einrichtung.</li> </ul>  |
|  | <p><b>WARNUNG (photobiologische Sicherheit)</b></p> <p>Dieses Symbol befindet sich auf dem Körper des Mikroskops (Tischgriffseite) und bedeutet Folgendes:</p> <ul style="list-style-type: none"> <li>• Risikogruppenklassifizierung der photobiologischen Sicherheit der Diaskop-Beleuchtung</li> <li>• Blicken Sie nicht in die Diaskop-Beleuchtung.</li> </ul> <p>Weitere Informationen finden Sie unter  <b>WARNUNG</b>, „7. Photobiologische Sicherheit“ sowie „8. Blicken Sie nicht in den Beleuchtungsbereich“</p> |



### Symbole WARNUNG und VORSICHT

Die Sicherheitshinweise in diesem Handbuch sind mit den folgenden Symbolen gekennzeichnet, um ihre Bedeutung hervorzuheben. Befolgen Sie zu Ihrer eigenen Sicherheit stets alle Anweisungen, die mit diesen Symbolen gekennzeichnet sind.

| Symbol  | Inhalt   |
|---|--|
|  <b>WARNUNG</b>  | Nichtbeachtung von mit diesem Symbol gekennzeichneten Anweisungen kann zu schweren oder tödlichen Verletzungen führen. |
|  <b>VORSICHT</b> | Nichtbeachtung von mit diesem Symbol gekennzeichneten Anweisungen kann zu Verletzungen oder Sachschäden führen.        |



## WARNUNG

### 1. Nicht zerlegen.

Das Zerlegen dieses Geräts kann Stromschläge oder Fehlfunktionen nach sich ziehen. Fehlfunktionen und Schäden durch Zerlegung sind nicht von der Garantie abgedeckt. Bauen Sie keine Teile auseinander, außer Sie werden in diesem Handbuch dazu aufgefordert. Wenden Sie sich bei Problemen mit dem Gerät an einen Nikon-Vertreter in Ihrer Nähe.

### 2. Lesen Sie sich die Anweisungen gründlich durch.

Lesen Sie sich für einen sicheren Gebrauch dieses Handbuch sowie die Handbücher anderer Ausrüstung durch, die mit diesem Gerät verwendet werden soll. Beachten Sie insbesondere die Warn- und Vorsichtshinweise am Anfang der Handbücher.

### 3. Eingangsspannung, Netzteil, Netzkabel

Das Netzteil für die Stromversorgung dieses Geräts kann mit 100 bis 240 V AC bei 50 bis 60 Hz verwendet werden. Verwenden Sie nur das in „Chapter 7 Specifications“ angegebene Netzteil und Netzkabel. Die Verwendung eines anderen Netzteils oder Netzkabels kann zu Fehlfunktionen oder einem Brand führen.

- Vermeiden Sie den Einsatz des Geräts in einer Umgebung mit übermäßig schwankender Versorgungsspannung.
- Das Netzteil für dieses Gerät entspricht der Schutzklasse I gegen Stromschläge. Schließen Sie es immer an eine Erdung an.
- Wenn das Netzteil verdeckt wird oder Gegenstände auf dem Netzteil abgelegt werden, kann dies die Wärmeableitung beeinträchtigen, wodurch das Netzteil ungewöhnlich heiß wird.

### 4. Umgang mit brennbaren Lösungsmitteln

Die folgenden brennbaren Lösungsmittel werden mit dem Gerät verwendet:

- Immersionsöl (Nikon Immersionsöl für Ölimmersion)
- Ethanol (Ethylalkohol oder Methylalkohol zur Reinigung optischer Bauteile)
- Petroleumbenzin (zum Abwischen des Immersionsöls)
- Medizinischer Alkohol (zur Desinfektion des Mikroskops)

Halten Sie offenes Feuer stets fern von diesen Lösungsmitteln. Lesen Sie sich bei Verwendung eines Lösungsmittels sorgfältig die Herstelleranweisungen durch und achten Sie auf die korrekte und sichere Verwendung.

Beachten Sie bei der Verwendung eines Lösungsmittels in Verbindung mit diesem Produkt die folgenden Vorsichtsmaßnahmen:

- Halten Sie Lösungsmittel vom Gerät und von dessen Umgebung fern, während Sie das Netzteil oder Netzkabel anschließen oder vom Produkt trennen.
- Verschütten Sie kein Lösungsmittel.

### 5. Gefährliche Proben

Dieses Mikroskop ist hauptsächlich für die Betrachtung von Proben wie Zellen und Gewebe vorgesehen, die auf einem Objektträger fixiert sind.

Prüfen Sie beim Umgang mit einer Probe, ob diese gefährlich ist. Befolgen Sie beim Umgang mit gefährlichen Proben die Standardverfahren Ihres Labors. Tragen Sie beim Umgang mit ansteckenden Proben Gummihandschuhe, um sich vor Ansteckung zu schützen, und berühren Sie die Probe nicht.

Falls eine solche Probe mit dem Mikroskop in Kontakt kommt, dekontaminieren Sie die kontaminierte Stelle entsprechend des Standardverfahrens Ihres Labors.



## WARNUNG

### 6. Hinweise zur Bedienung der Schieber an der Kondensoreinheit

Ein Schieberegler für die Mikroskopie hat zwei festgelegte Positionen. Er ist an der Kondensoreinheit angebracht und dient zum Umschalten der Beobachtungsmethoden oder Vergrößerungen durch Veränderung der eingestellten Position. Das helle Licht kann das Okularrohr erreichen, wenn Sie mittels des Schiebereglers die eingestellte Position ändern.

Schauen Sie nicht durch das Okular oder schalten Sie die Diaskop-Beleuchtung aus, wenn Sie einen Schieberegler betätigen.

Insbesondere bei der Diaskop-Fluoreszenzmikroskopie wird die sehr helle Beleuchtung verwendet, sodass die intensiven Blitze das Okularrohr erreichen könnten, wenn Sie den Schieberegler betätigen.

### 7. Photobiologische Sicherheit

Dieses Gerät entspricht der Sicherheitsnorm IEC 62471 („Photobiologische Sicherheit von Lampen und Lampensystemen“).

Die Beleuchtung des Objektstischs und das Licht vom binokularen Teil des Okularrohrs oder des Lehrkopfes und Licht vom Kameraport des trinokularen Okularrohrs entsprechen der folgenden Risikogruppe. Der Abstand (Gefahrenabstand) vom Objektstisch, dem binokularen Teil des Okularrohrs, des Lehrkopfes oder von der Öffnung des Kameraports, bei dem die Risikogruppenklassifizierung der Ausnahmegruppe entspricht, die keine photobiologischen Schäden verursacht, lautet wie folgt.

|  | Risikogruppenklassifizierung | Gefahrenabstand |
|--|------------------------------|-----------------|
| <b>Risiko von Netzhautschäden durch blaues Licht</b>   | Risikogruppe 3               | 36 m            |
| <b>Gefahr von Augenschäden durch Infrarotstrahlung</b> | Risikogruppe 3               | 127 m           |

Beleuchtung in Risikogruppe 3 kann gefährlich sein. Achten Sie auf die Helligkeitseinstellung des Helligkeitsreglers, und blicken Sie nicht zu lange in eine starke Lichtquelle.

- Die LED-Lichtquelle ist im unteren Teil des Mikroskops integriert. Das Beleuchtungslicht von der Feldlinse geht durch den Kondensator und beleuchtet die Probe. Blicken Sie nicht auf die Kondensatorlinse, die Probe oder den Randbereich der Probe und blicken Sie nicht in die Feldlinse.
- Blicken Sie nicht in das starke Licht vom binokularen Teil des Okularrohrs oder des Lehrkopfes.
- Entfernen Sie die Okulare nicht vom binokularen Teil, während die Beleuchtung eingeschaltet ist.
- Blicken Sie nicht direkt von oben in starkes Licht vom Kameraport.
- Bringen Sie die im Lieferumfang enthaltene Abdeckung am Kameraport an, wenn Sie die Kamera nicht verwenden.



## WARNUNG

### 8. Blicken Sie nicht in den Beleuchtungsbereich.

Das folgende Warnetikett, auf dem vor dem höchsten Risiko (Risikogruppe 3) für die photobiologische Sicherheit gewarnt wird, ist an der Griffseite des Objektisches angebracht, um den Benutzer an die folgenden Vorsichtsmaßnahmen zu erinnern. (Die Positionen dieses Etiketts finden Sie in der Abbildung unter „Chapter 1 Nomenclature of Each Part“.)



#### **WARNUNG (Risikogruppe 3)**

Infrarotstrahlung und möglicherweise gefährliches Licht werden vom Kameraanschluss abgegeben, wenn das trinokulare Okular verwendet wird.  
Blicken Sie niemals in den Kameraanschluss.

#### **VORSICHT (Risikogruppe 2)**

Möglicherweise tritt bei Verwendung einer Diaskop-Beleuchtung von der Kondensorlinse gefährliches Licht aus.  
Blicken Sie nicht in das ausgestrahlte Licht. Es kann schädlich für die Augen sein.

#### **HINWEIS (Risikogruppe 1)**

Bei Verwendung einer Diaskop-Beleuchtung tritt möglicherweise gefährliches Licht von den Okularlinsen aus.  
Vermeiden Sie es, Objekte lange mit starker Beleuchtung mikroskopisch zu betrachten.



## VORSICHT

### 1. Zusammenbau des Mikroskops

- Bauen Sie das Mikroskop nicht bei angeschlossenem Netzteil zusammen.
- Achten Sie darauf, sich nicht die Finger oder Hände einzuklemmen.

### 2. Verhindern Sie, dass das Gerät nass wird oder Fremdstoffe in das Gerät eindringen.

Lassen Sie das Gerät nicht nass werden, da dies zu Fehlfunktionen, Überhitzung oder Stromschlägen führen kann.

Wenn versehentlich Wasser oder andere Flüssigkeiten auf dem Gerät verschüttet werden, ziehen Sie das Netzkabel sofort vom Netzteil ab. Wischen Sie dann die Flüssigkeit mit einem trockenen Tuch ab.

Das Eindringen von Fremdstoffen kann ebenfalls zu Fehlfunktionen führen. Falls Flüssigkeiten oder Fremdstoffe in das Gerät gelangen, stellen Sie den Gebrauch des Geräts ein und wenden Sie sich an Ihren Nikon-Ansprechpartner.

### 3. Bewegen des Geräts

- Das Mikroskop verfügt über Haltegriffe. Es befinden sich zwei Haltegriffe an beiden Seiten der Basis und zwei Griffe am Arm auf der Rückseite des Mikroskops. Halten Sie das Mikroskop beim Tragen fest an diesen Haltegriffen.
- Das Aufbewahrungsfach auf der Rückseite des Mikroskops ist kein Haltegriff. Halten Sie das Gerät nicht daran fest, da dort das Netzteil und das Netzkabel aufbewahrt werden.
- Halten Sie das Gerät beim Bewegen nicht an den Fokusdrehknöpfen, dem Okularrohr, dem Objektisch usw. fest. Die Teile können sich lösen oder zu Fehlfunktionen führen.

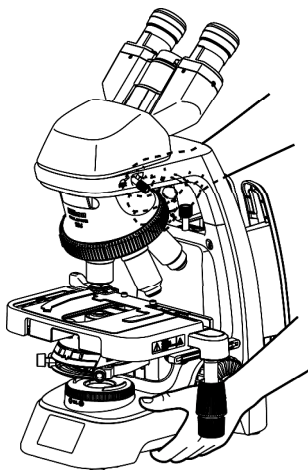
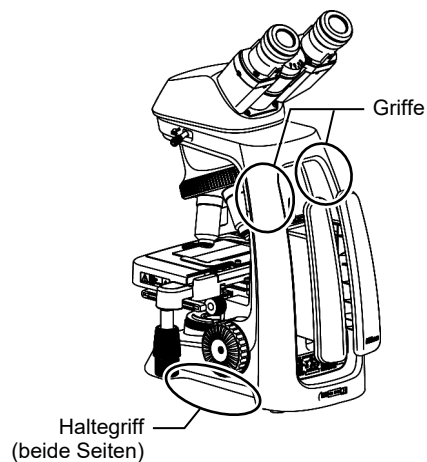

Halten Sie einen Griff und einen Haltegriff fest.

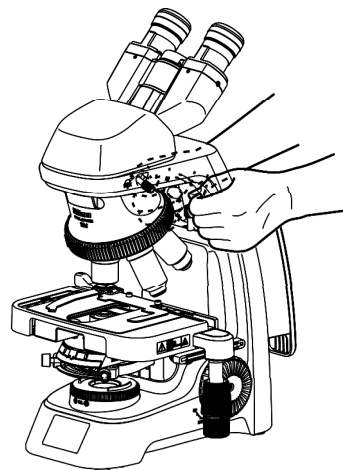

Halten Sie die Griffe fest.

### 4. Entsorgung des Mikroskops



Entsorgen Sie das Mikroskop entsprechend den Standardverfahren zur Entsorgung kontaminierter Geräte in Ihrer Einrichtung, um biologischen Risiken vorzubeugen.

## Consignes de sécurité

Ce produit a été conçu et fabriqué de façon à ne présenter aucun risque de sécurité lié à son utilisation. Cependant, une utilisation incorrecte ou le non-respect des consignes de sécurité fournies peut entraîner des blessures ou des dommages matériels. Pour garantir une utilisation correcte, lisez attentivement ce manuel avant d'utiliser le produit. Ne jetez pas ce manuel et gardez-le à portée de main pour pouvoir le consulter facilement.

### Signification des symboles utilisés sur le produit

Les symboles qui apparaissent sur le produit indiquent qu'il est nécessaire de faire preuve de prudence à tout moment pendant l'utilisation. Reportez-vous toujours au manuel d'instructions et lisez les instructions correspondantes avant de manipuler toute pièce sur laquelle le symbole a été apposé.

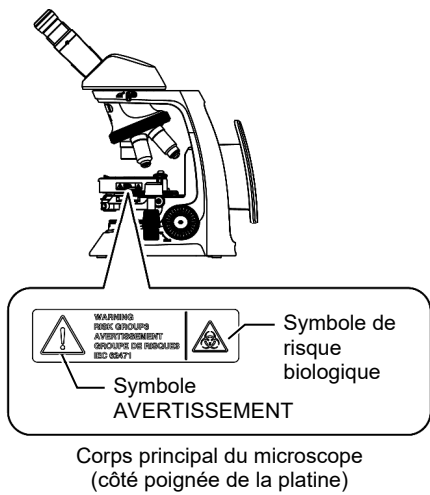

| Symbole   | Contenu   |
|---|---|
|    | <p><b>Risque biologique</b></p> <p>Ce symbole se trouve sur le boîtier du microscope (côté poignée de la platine) et attire l'attention sur les éléments suivants :</p> <ul style="list-style-type: none"> <li>• <b>AVERTISSEMENT</b> : Le produit peut présenter un risque biologique si un échantillon est renversé sur le produit.</li> <li>• Pour éviter toute exposition à un risque biologique, ne touchez pas les pièces contaminées à mains nues.</li> <li>• Décontaminez les pièces contaminées conformément aux procédures standard de votre établissement.</li> </ul>  |
|  | <p><b>AVERTISSEMENT (sécurité photobiologique)</b></p> <p>Ce symbole se trouve sur le boîtier du microscope (côté poignée de la platine) et attire l'attention sur les éléments suivants :</p> <ul style="list-style-type: none"> <li>• Classification groupe de risque de sécurité photobiologique de l'éclairage diascopique</li> <li>• Ne pas regarder l'éclairage diascopique.</li> </ul> <p>Pour plus de détails, voir  <b>AVERTISSEMENT</b>, « 7. Sécurité photobiologique » et « 8. Ne regardez pas la section d'éclairage. »</p> |



Corps principal du microscope (côté poignée de la platine)

### Symboles AVERTISSEMENT et MISE EN GARDE

Les consignes de sécurité de ce manuel sont signalées par les symboles suivants pour souligner leur importance. Pour votre sécurité, suivez toujours les instructions indiquées par ces symboles.

| Symbole  | Contenu  |
|--|--|
|  <b>AVERTISSEMENT</b> | Le non-respect des instructions signalées par ce symbole peut entraîner des blessures graves, voire mortelles. |
|  <b>MISE EN GARDE</b> | Le non-respect des instructions signalées par ce symbole peut entraîner des blessures ou des dégâts matériels. |



## AVERTISSEMENT

### 1. Ne pas démonter.

Le démontage de ce produit peut provoquer une électrocution ou un dysfonctionnement. Les dysfonctionnements et les dommages dus au démontage ne sont pas garantis. Ne démontez aucune pièce à moins d'y être invité dans ce manuel. Si vous rencontrez des problèmes avec le produit, contactez votre représentant Nikon le plus proche.

### 2. Lisez attentivement les instructions.

Pour des raisons de sécurité, lisez attentivement ce manuel et les manuels des autres équipements à utiliser avec ce produit. Veillez notamment à respecter les avertissements et les mises en garde figurant au début des manuels.

### 3. Tension d'entrée, adaptateur secteur, câble d'alimentation

L'adaptateur secteur pour l'alimentation de ce produit peut être utilisé avec 100 à 240 VCA, de 50 à 60 Hz. Utilisez uniquement l'adaptateur secteur et le câble d'alimentation spécifiés dans « Chapter 7 Specifications ». L'utilisation d'un autre adaptateur secteur ou câble d'alimentation peut entraîner un dysfonctionnement ou un incendie.

- Évitez d'utiliser le produit dans un environnement où la tension d'alimentation peut fluctuer excessivement.
- L'adaptateur secteur pour ce produit est catégorisé en classe I pour la protection contre l'électrocution. Veillez à le connecter à une borne de terre de protection.
- Si l'adaptateur secteur est couvert ou si des éléments sont placés sur l'adaptateur secteur, la dissipation de la chaleur peut être limitée, ce qui risque d'entraîner une surchauffe anormale.

### 4. Manipulation de solvants inflammables

Les solvants inflammables suivants sont utilisés avec le produit :

- Huile d'immersion (huile d'immersion Nikon pour les objectifs à immersion d'huile)
- Alcool absolu (alcool éthylique ou alcool méthylique pour le nettoyage des pièces optiques)
- Essence de pétrole (pour essuyer l'huile d'immersion)
- Alcool médical (pour la désinfection du microscope)

Ne tenez jamais une flamme à proximité de ces solvants. Si vous avez recours à un solvant, veillez à l'utiliser de manière correcte et sûre en lisant attentivement les instructions fournies par le fabricant du solvant.

Lorsque vous utilisez un solvant avec ce produit, prenez les précautions suivantes :

- Tenez les solvants à l'écart du produit et de son environnement lorsque vous branchez/débranchez l'adaptateur secteur ou le câble d'alimentation.
- Veillez à ne pas renverser les solvants.

### 5. Échantillons dangereux

Ce microscope est principalement destiné à l'observation microscopique d'un échantillon tel que des cellules et des tissus fixés sur une lame.

Lorsque vous manipulez un échantillon, vérifiez si celui-ci est dangereux. Manipulez les échantillons dangereux conformément à la procédure standard de votre laboratoire. Si l'échantillon est de nature infectieuse, portez des gants en caoutchouc pour éviter toute infection et veillez à ne pas toucher l'échantillon.

Si un échantillon de ce type entre en contact avec le microscope, décontaminez la partie contaminée conformément à la procédure standard de votre laboratoire.



## AVERTISSEMENT

### 6. Notes sur le fonctionnement des curseurs de la partie condenseur

Un curseur pour microscope a deux positions définies. Il est fixé à la partie condenseur et utilisé pour changer les méthodes d'observation ou les grossissements en changeant la position définie. La lumière vive peut atteindre le tube d'oculaire lorsque vous déplacez le curseur pour modifier la position définie.

Retirez vos yeux des binoculaires ou éteignez l'éclairage diascopique lorsque vous opérez un curseur.

En particulier dans la microscopie par fluorescence diascopique, un éclairage très lumineux est utilisé, de sorte que des flashes intenses peuvent atteindre le tube d'oculaire lorsque vous opérez le curseur.

### 7. Sécurité photobiologique

Ce produit est conçu et fabriqué conformément à la norme de sécurité CEI 62471 « Sécurité photobiologique des lampes et des appareils utilisant des lampes ».

L'éclairage près de la platine et la lumière provenant de la partie binoculaire du tube oculaire ou de la tête d'enseignement, et la lumière provenant du port de caméra du tube trinoculaire sont classés dans le groupe de risque suivant. La distance (distance de sécurité) par rapport à la platine ou à la partie binoculaire du tube d'oculaire ou de la tête d'enseignement, ou à l'ouverture du port de caméra, où la classification du groupe de risque est équivalente au groupe exempté qui ne cause pas de blessure photobiologique, est la suivante.

|   | Classification du groupe de risques | Distance de sécurité |
|---|-------------------------------------|----------------------|
| <b>Risques pour la rétine liés à la lumière bleue</b> | Groupe de risque 3                  | 36 m                 |
| <b>Danger de rayonnement infrarouge pour les yeux</b> | Groupe de risque 3                  | 127 m                |

L'éclairage des appareils du groupe de risque 3 peut être dangereux. Faites attention au réglage de la luminosité à l'aide du bouton de réglage correspondant et évitez de regarder une source forte de lumière pendant une période prolongée.

- La source lumineuse à LED se situe sous le microscope. La lumière d'éclairage de l'objectif de champ traverse le condenseur et illumine l'échantillon. Ne regardez pas l'objectif du condenseur, l'échantillon ou la périphérie de l'échantillon et ne regardez pas dans l'objectif de champ.
- Ne regardez pas la lumière intense de la partie binoculaire du tube d'oculaire ou de la tête d'enseignement.
- Ne retirez pas les oculaires de la partie binoculaire lorsque l'éclairage est allumé.
- Ne regardez pas la lumière puissante du port de caméra directement par au-dessus.
- Si vous ne branchez pas la caméra, mettez en place le capuchon fourni sur le port de caméra.





## AVERTISSEMENT

### 8. Ne regardez dans la section d'éclairage.

L'étiquette d'avertissement suivante indiquant le risque le plus élevé (groupe de risque 3) pour la sécurité photobiologique est apposée sur le côté poignée de la platine afin de rappeler à l'utilisateur les précautions suivantes. (Pour connaître l'emplacement de cette étiquette, reportez-vous à la figure dans « Chapter 1 Nomenclature of Each Part »).



#### **AVERTISSEMENT (Groupe de risque 3)**

Une lumière infrarouge et potentiellement dangereuse est émise du port de caméra lorsque le tube trinoculaire est utilisé.

Ne regardez jamais dans le port de caméra.

#### **MISE EN GARDE (Groupe de risque 2)**

Une lumière potentiellement dangereuse est émise par l'objectif du condenseur lorsque l'éclairage diascopique est utilisé.

Ne regardez pas la lumière émise. Elle peut être dangereuse pour les yeux.

#### **AVIS (Groupe de risque 1)**

Une lumière potentiellement dangereuse est émise par les objectifs de l'oculaire lorsque l'éclairage diascopique est utilisé.

Évitez les observations microscopiques de longue durée avec un éclairage puissant.



## MISE EN GARDE

### 1. Assemblage du microscope

- Assemblez le microscope lorsque l'adaptateur secteur n'est pas connecté.
- Veillez à ne pas vous pincer les doigts ni les mains.

### 2. Maintenez le produit à l'abri de l'humidité et ne laissez pas pénétrer de corps étrangers.

Maintenez le produit à l'abri de l'humidité afin d'éviter tout dysfonctionnement, surchauffe ou électrocution.

Si de l'eau ou d'autres liquides sont accidentellement renversés sur le produit, débranchez immédiatement le câble d'alimentation de l'adaptateur secteur. Essayez ensuite le liquide à l'aide d'un chiffon sec.

La pénétration de corps étrangers peut également entraîner un dysfonctionnement. Si des liquides ou des corps étrangers pénètrent dans le produit, cessez d'utiliser le produit et contactez votre représentant Nikon le plus proche.

### 3. Déplacement du produit

- Le microscope est doté de poignées de transport. Deux poignées des deux côtés de la base et deux poignées sur le bras à l'arrière du microscope. Lorsque vous transportez le microscope, tenez-le fermement par ces poignées.
- La pièce de stockage à l'arrière du microscope n'est pas une poignée. Ne tenez pas cette pièce car elle permet de ranger l'adaptateur secteur et le câble d'alimentation.
- Lorsque vous déplacez le produit, ne le tenez pas par les boutons de mise au point, le tube d'oculaire, la platine, etc. Les pièces peuvent se détacher et provoquer des dysfonctionnements.

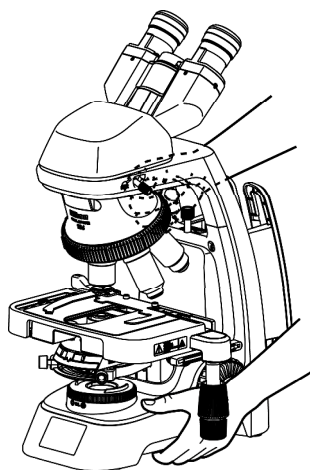
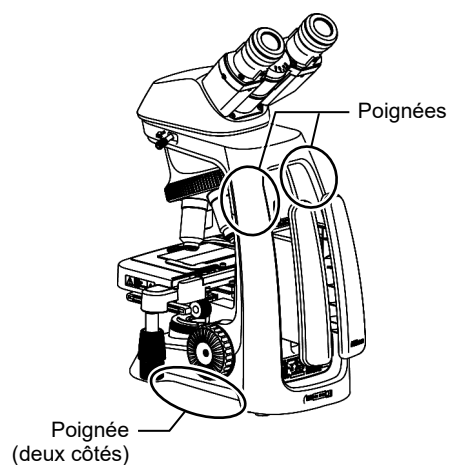

Tenir deux poignées.

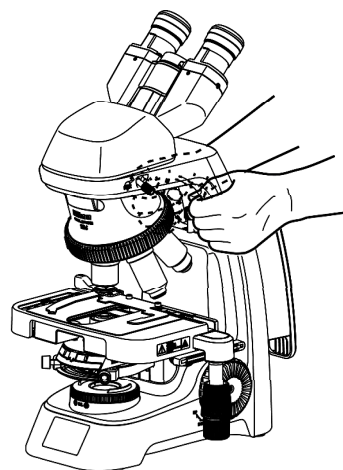

Tenir les poignées.

### 4. Mise au rebut du microscope



Pour éviter tout risque biologique, mettez le microscope au rebut comme un équipement contaminé, conformément aux procédures standard de votre établissement.

## Precauciones de seguridad



Aunque el proceso de diseño y fabricación de este producto garantiza su uso seguro, si lo utiliza de forma incorrecta o no sigue las instrucciones de seguridad indicadas se pueden producir lesiones personales o daños materiales. Para garantizar su uso correcto, lea atentamente este manual antes de utilizar el producto. No deseche este manual y manténgalo a mano para facilitar su consulta.

### Significado de los símbolos utilizados en el producto

Los símbolos que aparecen en el producto indican que debe usar el producto con precaución en todo momento. Consulte siempre el manual de instrucciones y lea las instrucciones correspondientes antes de manipular cualquier pieza en la que se haya colocado el símbolo.

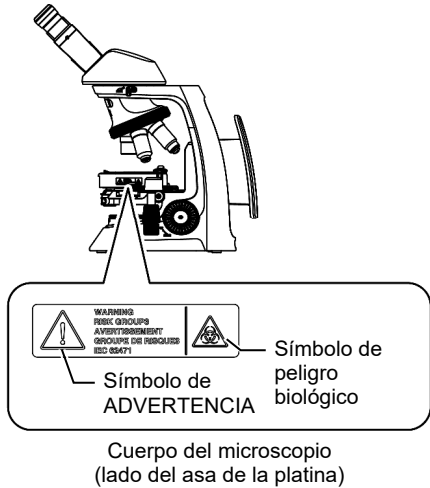

| Símbolo   | Explicación  |
|---|--|
|    | <p><b>Peligro biológico</b></p> <p>Este símbolo se puede encontrar en el cuerpo del microscopio (platina derecha) y advierte de lo siguiente:</p> <ul style="list-style-type: none"> <li>• <b>ADVERTENCIA:</b> El producto puede llegar a ser un peligro biológico si se derrama una muestra sobre el producto.</li> <li>• Para evitar la exposición al peligro biológico, no toque las piezas contaminadas sin guantes.</li> <li>• Descontamine las piezas contaminadas de acuerdo con los procedimientos habituales de su centro.</li> </ul>   |
|  | <p><b>ADVERTENCIA (seguridad fotobiológica)</b></p> <p>Este símbolo se puede encontrar en el cuerpo del microscopio (platina derecha) y advierte de lo siguiente:</p> <ul style="list-style-type: none"> <li>• Clasificación de grupo de riesgo fotobiológico de iluminación diascópica</li> <li>• No mire directamente a la luz diascópica.</li> </ul> <p>Para obtener más información, consulte  <b>ADVERTENCIA</b>, "7. Seguridad fotobiológica" y "8. No mire directamente a la fuente de iluminación."</p> |



 **Símbolo de ADVERTENCIA**  
 **Símbolo de peligro biológico**  
 Cuerpo del microscopio (lado del asa de la platina)

### Símbolos DE ADVERTENCIA y PRECAUCIÓN

Las instrucciones de seguridad de este manual están marcadas con los siguientes símbolos para destacar su importancia. Para garantizar su seguridad, siga siempre las instrucciones marcadas con estos símbolos.

| Símbolo  | Explicación   |
|--|---|
|  <b>ADVERTENCIA</b> | Si no se tienen en cuenta las instrucciones que indica este símbolo, pueden producirse lesiones graves o la muerte. |
|  <b>PRECAUCIÓN</b>  | Si no se tienen en cuenta las instrucciones que indica este símbolo, pueden producirse lesiones o daños materiales. |



## ADVERTENCIA

### 1. No desmonte el producto.

Si desmonta este producto, se pueden producir descargas eléctricas o es posible que dicho producto no funcione correctamente. Las averías y los daños ocasionados debidos al desmontaje del producto no están cubiertos por la garantía. No desmonte ninguna pieza a menos que se indique en este manual. Si tiene problemas con el producto, póngase en contacto con el representante de Nikon más cercano.

### 2. Lea las instrucciones detenidamente.

Para garantizar la seguridad, lea detenidamente este manual y los manuales del resto de equipos que va a utilizar con este producto. En concreto, asegúrese de seguir las advertencias y las precauciones que aparecen al principio de los manuales.

### 3. Tensión de entrada, adaptador de CA y cable de alimentación

El adaptador de CA que suministra alimentación a este producto se puede utilizar con entre 100 y 240 V de CA y a entre 50 y 60 Hz. Utilice únicamente el adaptador de CA y el cable de alimentación indicados en el "Chapter 7 Specifications." El uso de un adaptador de CA o cable de alimentación diferentes puede provocar una avería o un incendio.

- No utilice el producto en un entorno en el que la tensión de alimentación pueda fluctuar demasiado.
- El adaptador de CA de este producto es de Clase I en lo que respecta a la protección contra descargas eléctricas. Conecte siempre el producto a un terminal con puesta a tierra.
- Si el adaptador de CA está cubierto o hay algún componente sobre el adaptador de CA, la disipación del calor puede verse obstaculizada, lo que provoca que se caliente demasiado.

### 4. Manipulación de disolventes inflamables

Se utilizan los siguientes disolventes inflamables con el producto:

- Aceite de inmersión (aceite de inmersión Nikon para objetivos de inmersión en aceite)
- Alcohol absoluto (alcohol etílico o alcohol metílico para limpiar los componentes ópticos)
- Bencina de petróleo (para eliminar el aceite de inmersión)
- Alcohol de uso médico (para desinfectar el microscopio)

No sostenga nunca una llama cerca de estos disolventes. Si utiliza un disolvente, lea detenidamente las instrucciones proporcionadas por el fabricante para asegurarse de que lo usa de manera segura y correcta.

Si utiliza un disolvente con este producto, aplique las siguientes precauciones:

- Cuando vaya a enchufar/desenchufar el adaptador de CA o el cable de alimentación, mantenga los disolventes alejados del producto y de la zona circundante.
- No derrame los disolventes.

### 5. Muestras peligrosas

Este microscopio se utiliza principalmente en la observación microscópica de muestras, como células y tejidos adheridos a un portaobjetos.

Si va a manipular una muestra, compruebe si es peligrosa. Manipule las muestras peligrosas de acuerdo con el procedimiento habitual de su laboratorio. Si la muestra es infecciosa, use guantes de goma para evitar infecciones y no toque la muestra.

Si dicha muestra entra en contacto con el microscopio, descontamine la parte contaminada de acuerdo con el procedimiento habitual de su laboratorio.



## ADVERTENCIA

### 6. Notas sobre el uso de portaobjetos en el condensador

Un portaobjetos tiene dos posiciones fijas. Se coloca en el condensador y se utiliza para modificar el método de observación o el porcentaje de aumento al cambiar la posición. La luz brillante puede llegar al tubo ocular al mover el portaobjetos cuando se cambia de posición.

Aléjese de los binoculares o apague la luz diascópica cuando mueva el portaobjetos.

Especialmente en aplicaciones de microscopía fluorescente diascópica se utiliza una iluminación muy brillante, y es posible que la luz intensa llegue al tubo ocular al manipular el portaobjetos.

### 7. Seguridad fotobiológica

Este producto se ha diseñado y fabricado de acuerdo con la norma de seguridad IEC 62471 "Seguridad fotobiológica de lámparas y de los aparatos que utilizan lámparas".

La luz que hay alrededor de la platina y la procedente del binocular del tubo ocular o del cabezal, así como la luz del puerto de la cámara del tubo trinocular se incluyen en el siguiente grupo de riesgo. La distancia (distancia de peligro) desde la zona de alrededor de la platina o desde el binocular del tubo ocular o del cabezal, o desde la abertura del puerto de la cámara a la que se aplica la clasificación de grupo exento de riesgo que no produce lesiones fotobiológicas es la siguiente.

|  | Clasificación de grupo de riesgo | Distancia de peligro |
|--|----------------------------------|----------------------|
| <b>Peligro de luz azul para la retina</b>            | Grupo de riesgo 3                | 36 m                 |
| <b>Peligro de radiación infrarroja para los ojos</b> | Grupo de riesgo 3                | 127 m                |

La luz en el grupo de riesgo 3 puede ser peligrosa. Ajuste cuidadosamente el brillo con el botón de control de brillo y no mire hacia luz intensa durante mucho tiempo.

- La fuente de luz LED se encuentra en la parte inferior del microscopio. La fuente de iluminación de la lente de campo pasa por el condensador e ilumina la muestra. No mire directamente a la lente del condensador, a la muestra ni a los bordes de la muestra. Tampoco mire directamente a la lente de campo.
- No mire directamente a la luz potente de los binoculares del tubo ocular ni del cabezal.
- No retire los oculares del binocular cuando la luz esté encendida.
- No mire directamente desde arriba hacia la luz intensa procedente del puerto de la cámara durante mucho tiempo.
- Si no conecta la cámara, coloque la tapa suministrada en el puerto de la cámara.



## ADVERTENCIA

### 8. No mire directamente a la fuente de iluminación.

La siguiente etiqueta de advertencia que indica el nivel de riesgo más elevado (grupo de riesgo 3) de seguridad fotobiológica está colocada en el lado del asa de la platina para recordar al usuario las siguientes precauciones. (para ver la ubicación de esta etiqueta, consulte la imagen del "Chapter 1 Nomenclature of Each Part.")



#### **ADVERTENCIA (Grupo de riesgo 3)**

El puerto de la cámara emite luz infrarroja y luz potencialmente peligrosa cuando se utiliza el tubo ocular del trinocular.

No mire nunca al puerto de la cámara.

#### **ADVERTENCIA (Grupo de riesgo 2)**

La lente del condensador emite luz potencialmente peligrosa cuando se utiliza iluminación diascópica.

No mire directamente a la fuente de luz. Puede ser perjudicial para los ojos.

#### **AVISO (Grupo de riesgo 1)**

Las lentes de los oculares emiten luz potencialmente peligrosa cuando se utiliza iluminación diascópica.

Evite largas sesiones de observación en el microscopio con una iluminación potente.



## PRECAUCIÓN

### 1. Montaje del microscopio

- Monte el microscopio sin conectar el adaptador de CA.
- Tenga cuidado de no pillarse los dedos ni las manos.

### 2. No moje el producto ni deje que entren cuerpos extraños.

No deje que el producto se moje, ya que se podrían producir averías, sobrecalentamiento o descargas eléctricas.

Si se derraman accidentalmente agua u otros líquidos sobre el producto, desenchufe inmediatamente el cable de alimentación del adaptador de CA. A continuación, retire el líquido con un paño seco.

La entrada de cuerpos extraños también puede provocar averías. Si entran líquidos o cuerpos extraños en el producto, deje de usarlo y póngase en contacto con su representante de Nikon más cercano.

### 3. Transporte del producto

- El microscopio tiene varias asas de transporte. Hay dos asas de transporte en la base y dos en el brazo de la parte trasera del microscopio. Para transportar el microscopio, cójalo por dichas asas.
- La pieza para almacenamiento de la parte posterior del microscopio no es un asa. No coja el microscopio por esta pieza, ya que ahí se guardan el adaptador de CA y el cable de alimentación.
- Si va a transportar el producto, no lo coja por los tornillos, el tubo ocular, la platina, etc. Es posible que estas piezas se suelten o también que se produzcan averías.

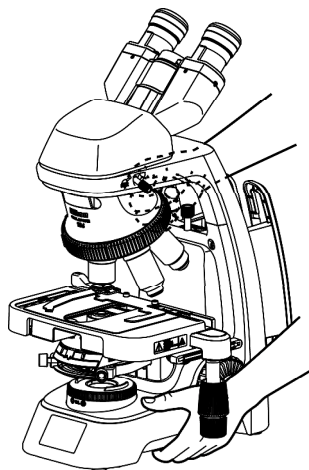
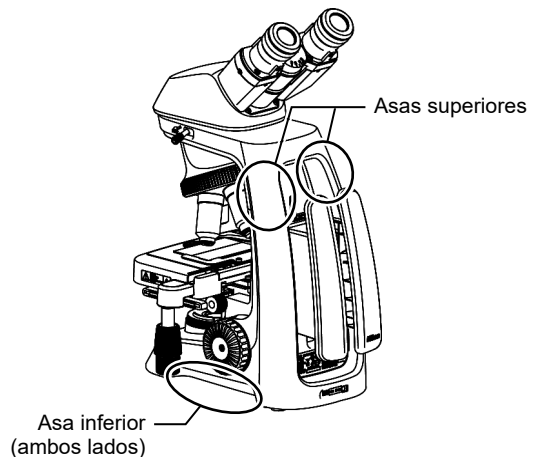

Sujete por un asa de transporte inferior y por un asa superior.

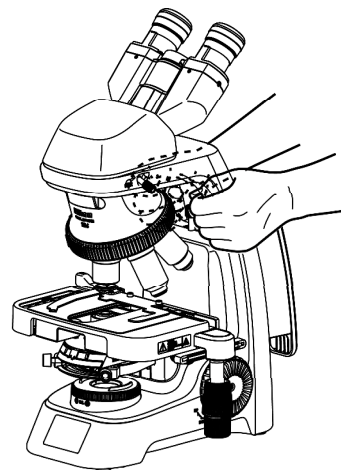

Sujete por ambas asas superiores.

### 4. Eliminación del microscopio



Para evitar peligros biológicos, deseche el microscopio como equipo contaminado de acuerdo con los procedimientos habituales de su centro.

## Precauzioni per la sicurezza

Sebbene questo prodotto sia stato progettato e realizzato per garantire la massima sicurezza durante l'uso, l'utilizzo non corretto o il mancato rispetto delle istruzioni di sicurezza possono causare lesioni personali o danni alla proprietà. Per garantire un utilizzo corretto, leggere attentamente il presente manuale prima di utilizzare il prodotto. Conservare il manuale e tenerlo a portata di mano per consultarlo in caso di necessità.

### Spiegazione dei simboli riportati sul prodotto

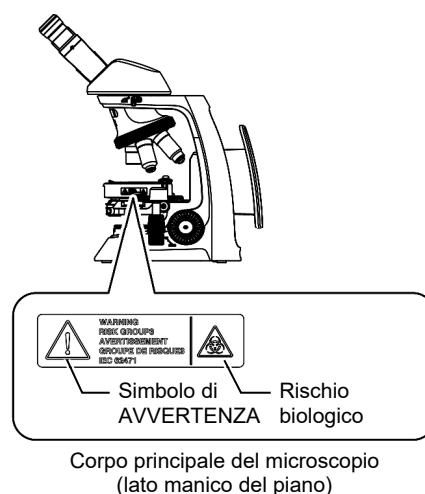

I simboli riportati sul prodotto indicano la necessità di prestare attenzione durante l'uso dello stesso. Consultare sempre il manuale di istruzioni e leggere le indicazioni pertinenti prima di utilizzare qualsiasi parte su cui è riportato il simbolo.

| Simbolo   | Spiegazione   |
|---|---|
|    | <p><b>Rischio biologico</b></p> <p>Questo simbolo può essere riportato sul piano del corpo del microscopio (lato del manico del piano) e indica quanto segue:</p> <ul style="list-style-type: none"> <li>• <b>AVVERTENZA:</b> l'eventuale contatto con un campione può rendere il prodotto biotossico.</li> <li>• Per evitare possibili esposizioni a rischi biologici, non toccare le parti contaminate a mani nude.</li> <li>• Decontaminare le parti seguendo le procedure standard in uso presso il proprio laboratorio.</li> </ul>   |
|  | <p><b>AVVERTENZA (sicurezza fotobiologica)</b></p> <p>Questo simbolo può essere riportato sul corpo del microscopio (lato del manico del piano) e indica quanto segue:</p> <ul style="list-style-type: none"> <li>• Classificazione del gruppo di rischio fotobiologico per la sicurezza dell'illuminazione diascopica</li> <li>• Non rivolgere lo sguardo verso l'illuminazione diascopica.</li> </ul> <p>Per i dettagli, vedere <b>AVVERTENZA</b>  "7. Sicurezza fotobiologica" e "8. Non rivolgere lo sguardo verso l'illuminazione".</p> |



### Simboli di AVVERTENZA e ATTENZIONE

Le istruzioni di sicurezza riportate nel presente manuale sono contrassegnate con i seguenti simboli per evidenziarne l'importanza. Per garantire la propria sicurezza, seguire sempre le istruzioni contrassegnate con questi simboli.

| Simbolo   | Spiegazione  |
|---|--|
|  <b>AVVERTENZA</b> | Il mancato rispetto delle istruzioni contrassegnate con questo simbolo può causare lesioni personali gravi o mortali.        |
|  <b>ATTENZIONE</b> | Il mancato rispetto delle istruzioni contrassegnate con questo simbolo può causare lesioni personali o danni alla proprietà. |





## AVVERTENZA

### 1. Non smontare il prodotto.

Lo smontaggio può causare elettrocuzione o malfunzionamenti. Eventuali malfunzionamenti e danni derivanti dallo smontaggio del prodotto non sono coperti dalla garanzia. Non smontare nessuna parte, tranne se espressamente indicato nel presente manuale. In caso di problemi con il prodotto, contattare il rappresentante Nikon di zona.

### 2. Leggere attentamente le istruzioni.

Per garantire la propria sicurezza, leggere attentamente il presente manuale e i manuali relativi agli altri strumenti da utilizzare con il prodotto. In particolare, seguire le indicazioni di avvertenza e di attenzione riportate all'inizio dei manuali.

### 3. Tensione in ingresso, adattatore CA, cavo di alimentazione

L'adattatore CA del prodotto può essere utilizzato con una tensione in ingresso compresa tra 100 e 240 VCA a 50-60 Hz. Utilizzare esclusivamente l'adattatore CA e il cavo di alimentazione specificati in "Chapter 7 Specifications." L'uso di un adattatore CA o di un cavo di alimentazione di tipo diverso può causare malfunzionamenti o incendi.

- Evitare di utilizzare il prodotto in ambienti soggetti a forti variazioni della tensione di alimentazione.
- L'adattatore CA per questo prodotto è classificato come apparecchio di Classe 1 per la protezione da scosse elettriche. Accertarsi di collegarlo a un terminale di messa a terra di protezione.
- Coprire l'adattatore CA o collocarvi degli oggetti potrebbe ridurre la dissipazione di calore e causarne il surriscaldamento.

### 4. Trattamento dei solventi infiammabili

I seguenti solventi infiammabili sono utilizzati con il prodotto:

- Olio per immersione (olio per immersione Nikon)
- Alcool puro (etilico o metilico per la pulizia dei componenti ottici)
- Benzina (per rimuovere l'olio per immersione)
- Alcool medico (per disinfettare il microscopio)

Non avvicinare mai fiamme ai solventi. Quando si utilizza un solvente, assicurarsi che la modalità d'impiego sia corretta e sicura leggendo accuratamente le istruzioni fornite dal produttore del solvente.

Quando si utilizza un solvente con questo prodotto, osservare le seguenti precauzioni:

- Tenere i solventi lontani dal prodotto e dalle aree circostanti durante le operazioni di collegamento/scollegamento dell'adattatore CA o del cavo di alimentazione.
- Fare attenzione a non rovesciare i solventi.

### 5. Campioni pericolosi

Il microscopio è destinato principalmente all'osservazione di campioni come cellule e tessuti su vetrino.

Durante la manipolazione di un campione, verificarne la pericolosità. Maneggiare i campioni pericolosi secondo la procedura standard in uso presso il proprio laboratorio. Se il campione è infettivo, indossare dei guanti di gomma per evitare infezioni e fare attenzione a non entrare in contatto con lo stesso.

Se un campione di questo tipo entra a contatto con il microscopio, decontaminare la parte interessata seguendo la procedura standard in uso presso il proprio laboratorio.



## AVVERTENZA

### 6. Note sull'azionamento dei cursori sulla parte del condensatore

Un cursore per microscopia ha due posizioni impostate. È fissato alla parte del condensatore e utilizzato per commutare i metodi di osservazione o gli ingrandimenti modificando la posizione impostata. La luce intensa potrebbe raggiungere il tubo oculare quando si sposta il cursore per cambiare la posizione impostata.

Rimuovere gli occhi dai binocoli o spegnere l'illuminazione diascopica quando si aziona un cursore.

Nella microscopia a fluorescenza diascopica in particolare viene utilizzata un'illuminazione molto intensa, pertanto i flash molto luminosi potrebbero raggiungere il tubo oculare quando si aziona il cursore.

### 7. Sicurezza fotobiologica

Questo prodotto è progettato e prodotto nel rispetto della norma di sicurezza IEC 62471 "Sicurezza fotobiologica delle lampade e dei sistemi di lampade".

L'illuminazione vicino al piano, la luce proveniente dalla parte binoculare del tubo oculare o della testa e la luce proveniente dalla porta della telecamera del tubo oculare trinoculare sono classificate nel seguente gruppo di rischio. La distanza (distanza di pericolo) dal piano o dalla parte binoculare del tubo oculare o della testa, o dall'apertura della porta della telecamera in cui la classificazione del gruppo di rischio è equivalente al gruppo esente che non causa lesioni fotobiologiche è la seguente.

|  | Classificazione gruppo di rischio | Distanza di pericolo |
|--|-----------------------------------|----------------------|
| <b>Rischio da luce blu</b>                               | Gruppo di rischio 3               | 36 m                 |
| <b>Pericolo di radiazioni a infrarossi per gli occhi</b> | Gruppo di rischio 3               | 127 m                |

L'illuminazione nel gruppo di rischio 3 può essere pericolosa. Fare attenzione durante la regolazione della luminosità tramite l'apposita manopola ed evitare di fissare una luce intensa per un periodo prolungato.

- La sorgente luminosa LED è integrata sotto il microscopio. La luce proveniente dall'obiettivo attraversa il condensatore e illumina il campione. Non fissare direttamente la lente del condensatore, il campione o la zona periferica del campione e non guardare nell'obiettivo.
- Non guardare direttamente la luce proveniente dalla parte binoculare del tubo oculare o dalla testa.
- Non rimuovere gli oculari dalla parte binoculare quando l'illuminazione è attiva.
- Non fissare dall'alto la luce intensa proveniente dalla porta della telecamera.
- Quando non si collega la telecamera, coprire la porta con l'apposito coperchio fornito in dotazione.



## AVVERTENZA

### 8. Non rivolgere lo sguardo verso l'illuminazione.

La seguente etichetta di avvertenza che indica il rischio più elevato (Gruppo di rischio 3) per la sicurezza fotobiologica è apposta sul lato manico del piano per ricordare all'utente le seguenti precauzioni. (Per la posizione di questa etichetta, vedere la figura in "Chapter 1 Nomenclature of Each Part").



#### **AVVERTENZA (Gruppo di rischio 3)**

quando si utilizza il tubo oculare trinoculare, dalla porta della telecamera vengono emesse luce infrarossa e una luce potenzialmente pericolosa.

Non guardare mai all'interno della porta della fotocamera.

#### **ATTENZIONE (Gruppo di rischio 2)**

quando si utilizza l'illuminazione diascopica, dalla lente del condensatore viene emessa una luce potenzialmente pericolosa.

Non fissare direttamente la luce emessa. Ciò potrebbe essere nocivo per gli occhi.

#### **AVVISO (Gruppo di rischio 1)**

quando si utilizza l'illuminazione diascopica, dalla lente dell'oculare viene emessa una luce potenzialmente pericolosa.

Evitare l'osservazione microscopica per un periodo prolungato con un'illuminazione intensa.



## ATTENZIONE

### 1. Montaggio del microscopio

- Montare il microscopio con l'adattatore CA non collegato.
- Fare attenzione a non schiacciare le dita e le mani.

### 2. Non bagnare il prodotto ed evitare l'ingresso di corpi estranei.

Assicurarsi che il prodotto non si bagni per evitare malfunzionamenti, surriscaldamento o elettrocuzione.

Se acqua o altri liquidi vengono accidentalmente versati sul prodotto, estrarre immediatamente il cavo di alimentazione dall'adattatore CA, quindi rimuovere il liquido con un panno asciutto.

Anche l'ingresso di corpi estranei può determinare malfunzionamenti. Se liquidi o corpi estranei entrano nel prodotto, interromperne l'uso e contattare il rappresentante Nikon di zona.

### 3. Trasporto del prodotto

- Il microscopio è dotato di rientranze e manici. Sono presenti due rientranze su entrambi i lati della base e due manici sul braccio posizionato sul retro del microscopio. Per trasportare il microscopio, afferrarlo saldamente dai manici e dalle rientranze.
- Il vano sulla parte posteriore del microscopio non è un manico. Non afferrarlo poiché viene utilizzato per riporre il cavo e l'adattatore CA.
- Per spostare il prodotto, non afferrare le manopole per la messa a fuoco, il tubo oculare, il piano, ecc. Queste parti possono staccarsi, causando malfunzionamenti.

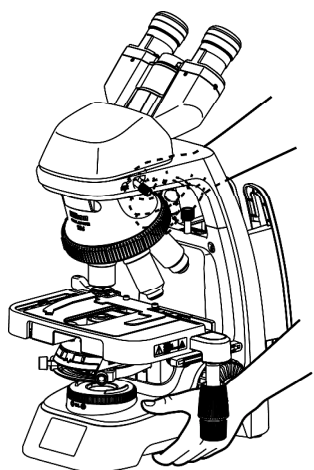
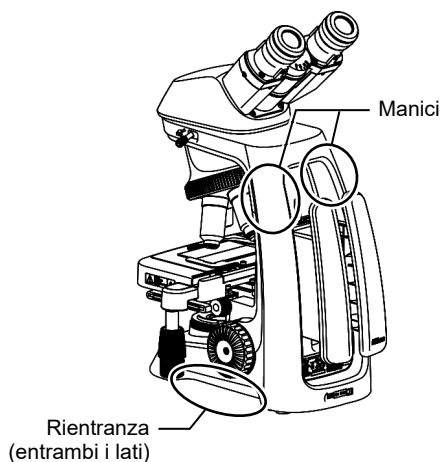

Tenere una rientranza e un manico.

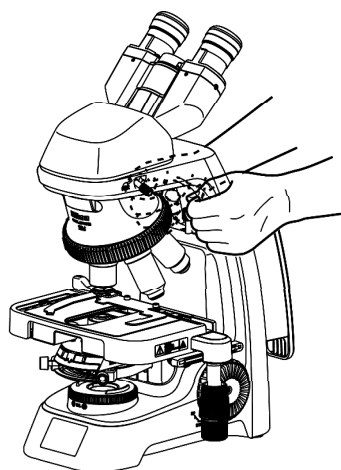

Tenere i manici.

### 4. Smaltimento del microscopio



Per evitare rischi biologici, smaltire il microscopio come rifiuto contaminato, in base alle procedure standard in uso presso il proprio laboratorio.

## Veiligheidsvoorschriften

Dit product is ontworpen voor veilig gebruik. Onjuist gebruik of het niet opvolgen van de veiligheidsvoorschriften kan leiden tot persoonlijk letsel of schade aan uw eigendom. Lees deze handleiding zorgvuldig voordat u het product in gebruik neemt voor een veilig gebruik. Bewaar deze handleiding voor een snelle raadpleging.

### De betekenis van de symbolen op het product

De symbolen op het product geven aan dat het product zorgvuldig moet worden gebruikt. Raadpleeg de instructiehandleiding en lees de relevante instructies door voordat u aan de slag gaat met een onderdeel van het product waarop het symbool is aangebracht.

| Symbol  | Inhoud  |
|---|---|
|    | <p><b>Biologisch gevaar</b></p> <p>Dit symbool bevindt zich op de objecttafel van de behuizing van de microscoop (aan de handgreepzijde van de objecttafel) en waarschuwt voor het volgende:</p> <ul style="list-style-type: none"> <li>• <b>WAARSCHUWING:</b> Het product kan biologisch gevaarlijk zijn wanneer een monster op het product wordt gemorst.</li> <li>• Om blootstelling aan biologisch gevaar te voorkomen, moet u de besmette onderdelen niet met blote handen aanraken.</li> <li>• Reinig de besmette onderdelen volgens de standaardprocedures van uw faciliteit.</li> </ul>                     |
|  | <p><b>WAARSCHUWING (fotobiologische veiligheid)</b></p> <p>Dit symbool bevindt zich op de behuizing van de microscoop (aan de handgreepzijde van de objecttafel) en waarschuwt voor het volgende:</p> <ul style="list-style-type: none"> <li>• Classificatie risicogroep fotobiologische veiligheid van diascopische belichting</li> <li>• Kijk niet in de diascopische belichting.</li> </ul> <p>Voor meer informatie, zie  <b>WAARSCHUWING "7. Photobiologische veiligheid" en "8. Kijk niet in de belichtingssectie".</b></p> |

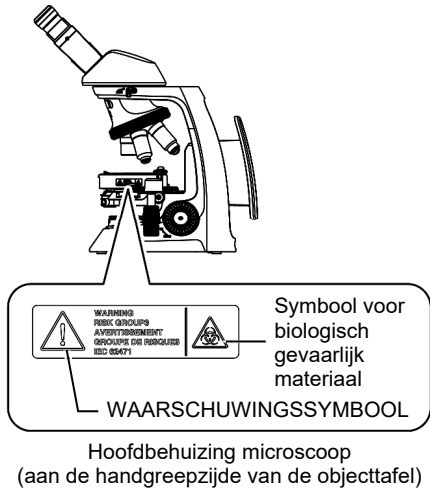



Symbol voor biologisch gevaarlijk materiaal

WAARSCHUWINGSSYMBOL

Hoofdbehuizing microscoop (aan de handgreepzijde van de objecttafel)

### De symbolen WAARSCHUWING en LET OP

De veiligheidsinstructies in deze handleiding zijn gemarkeerd met de volgende symbolen om het belang ervan te benadrukken. Volg voor uw veiligheid altijd de aanwijzingen die met deze symbolen zijn gemarkeerd.

| Symbol  | Inhoud   |
|---|--|
|  <b>WAARSCHUWING</b> | Het niet opvolgen van de aanwijzingen bij dit symbool kan leiden tot ernstig letsel of de dood.        |
|  <b>LET OP</b>       | Het niet opvolgen van de aanwijzingen bij dit symbool kan leiden tot letsel of schade aan eigendommen. |



## WAARSCHUWING

### 1. Niet demonteren.

Als u dit product demonteert, kan het product defect raken of kunt u een elektrische schok krijgen. Storingen en schade als gevolg van het demonteren van het product vallen niet onder de garantie. Demonteer geen onderdelen van dit product tenzij de instructies dit duidelijk aangeven. Wanneer u problemen ondervindt met het product, neemt u contact op met de Nikon-vertegenwoordiger bij u in de buurt.

### 2. Lees de instructies aandachtig door.

Lees voor uw veiligheid deze handleiding aandachtig door, alsmede de handleidingen voor andere apparatuur die u samen met dit product gebruikt. Volg met name de waarschuwingen en adviezen aan het begin van de handleidingen op.

### 3. Ingangsspanning, lichtnetadapter en netsnoer

De lichtnetadapter van dit product is geschikt voor 100 tot 240 VAC, 50/60 Hz. Gebruik alleen de lichtnetadapter en het netsnoer zoals gespecificeerd in "Chapter 7 Specifications". Het gebruik van een andere lichtnetadapter of een ander netsnoer kan leiden tot storingen of brand.

- Gebruik het product niet in een omgeving waar de ingangsspanning sterk fluctueert.
- De lichtnetadapter voor dit product is geclassificeerd als Klasse I voor bescherming tegen elektrische schokken. Sluit het product aan op een geaard stopcontact.
- Wanneer de lichtnetadapter is bedekt tijdens het gebruik, kan de warmteafvoer worden belemmerd, waardoor de lichtnetadapter abnormaal heet wordt.

### 4. Omgaan met brandbare oplosmiddelen

De volgende brandbare oplosmiddelen worden met het product gebruikt:

- Olie-immersie (Nikon olie-immersie voor olie-immersie objectieven)
- Pure alcohol (ethylalcohol of methanol voor het reinigen van optische onderdelen)
- Petroleumbenzine (voor het verwijderen van de olie-immersie)
- Medische alcohol (voor het desinfecteren van de microscoop)

Houd geen vlam in de buurt van deze oplosmiddelen. Wanneer u een oplosmiddel gebruikt, moet u ervoor zorgen dat het correct en veilig wordt gebruikt door de instructies van de fabrikant van het oplosmiddel grondig te lezen.

Wanneer u bij dit product een oplosmiddel gebruikt, neem dan de volgende voorzorgsmaatregelen in acht:

- Houd oplosmiddelen uit de buurt van het product wanneer u de lichtnetadapter of het netsnoer aansluit of loskoppelt.
- Zorg ervoor dat u geen oplosmiddelen morst.

### 5. Gevaarlijke monsters

De microscoop is bedoeld voor microscopische waarneming van een monster, zoals cellen en weefsels op het objectglas.

Wanneer u werkt met een monster, moet u controleren of het monster gevaarlijk is. Volg de standaardprocedure van uw laboratorium wanneer u met gevaarlijke monsters werkt. Als het monster van besmettelijke aard is, moet u rubberen handschoenen dragen om infecties te voorkomen. Vermijd contact met het monster.

Wanneer een dergelijk monster in contact met de microscoop komt, moet u het besmette gedeelte ontsmetten volgens de standaardprocedure van uw laboratorium.



## WAARSCHUWING

### 6. Opmerkingen over de bediening van de schuifregelaars op het condensorgedeelte

Een schuifregelaar voor microscopie heeft twee ingestelde posities. De regelaar is bevestigd aan het condensorgedeelte en wordt gebruikt voor het wisselen van de observatiemethoden of vergrotingen door de ingestelde positie te wijzigen. Het heldere licht kan het oculair bereiken wanneer u de schuifregelaar beweegt om de ingestelde positie te wijzigen.

Kijk niet door het vergrootglas of schakel de diascopische belichting uit wanneer u een schuifregelaar bedient.

Vooraf bij diascopische fluorescentiemicroscopie wordt de zeer heldere verlichting gebruikt, waardoor de krachtige flitsen het oculair kunnen bereiken wanneer u de schuifregelaar bedient.

### 7. Fotobiologische veiligheid

Dit product is ontworpen en gemaakt in overeenstemming met IEC-standaard 62471, "Fotobiologische veiligheid van lampen en lampsystemen".

Verlichting in de buurt van de objecttafel en licht van het binoculaire deel van het oculair of de tubus, en licht van de camerapoort van het trinoculaire oculair worden ingedeeld in de volgende risicogroep. De afstand (gevaarlijke afstand) van de objecttafel of van het binoculaire deel van het oculair of de tubus, of van de opening van de camerapoort waar de classificatie van risicogroepen equivalent is aan de vrijgestelde groep die geen fotobiologisch letsel veroorzaakt is als volgt.

|  | Classificatie van risicogroep | Gevaarlijke afstand |
|--|-------------------------------|---------------------|
| <b>Gevaar van blauw licht voor het netvlies</b>  | Risicogroep 3                 | 36 m                |
| <b>Gevaar van infraroodstraling voor de ogen</b> | Risicogroep 3                 | 127 m               |

Verlichting in risicogroep 3 kan gevaarlijk zijn. Stel de verlichting juist af met de verlichtingsknop en kijk niet te lang in fel licht.

- De ledlichtbron bevindt zich onder in de microscoop. De belichting van de veldlens gaat door de condensor en verlicht het monster. Kijk niet naar de condensorlens, het monster of de rand van het monster en kijk niet in de veldlens.
- Kijk niet in het felle licht van het binoculaire deel van het oculair of de tubus.
- Verwijder de oculairs niet van het binoculaire gedeelte wanneer de verlichting is ingeschakeld.
- Kijk niet in het felle licht van de camerapoort of direct boven de camerapoort.
- Wanneer de camera niet is bevestigd, moet u de dop op de camerapoort doen.



## WAARSCHUWING

### 8. Kijk niet in de belichtingssectie.

Het volgende waarschuwingsplaatje dat het hoogste risico (risicogroep 3) voor de fotobiologische veiligheid aangeeft, is aangebracht aan de handgreepzijde van de objecttafel om de gebruiker te herinneren aan de volgende voorzorgsmaatregelen. (Zie de afbeelding in "Chapter 1 Nomenclature of Each Part" voor de locaties van dit label.)



#### **WAARSCHUWING (risicogroep 3)**

Infrarood en mogelijk gevaarlijk licht komt uit de camerapoort wanneer het trinoculaire oculair wordt gebruikt.

Kijk nooit in de camerapoort.

#### **LET OP (risicogroep 2)**

Mogelijk gevaarlijk licht komt uit de condensorlens wanneer diascopische verlichting wordt gebruikt.

Staar niet naar het uitgestraalde licht. Het kan schadelijk zijn voor de ogen.

#### **OPMERKING (risicogroep 1)**

Mogelijk gevaarlijk licht komt uit de oculaire lenzen wanneer diascopische verlichting wordt gebruikt.

Vermijd langdurige microscopische observatie met felle verlichting.





## LET OP

### 1. Het monteren van de microscoop

- Wanneer u de microscoop monteert, moet de lichtnetadapter niet zijn aangesloten.
- Zorg ervoor dat uw vingers en handen niet bekneld raken tijdens de montage.

### 2. Zorg dat het product niet nat wordt of dat er vreemde objecten in het product terechtkomen.

Zorg ervoor dat het product niet nat wordt. Dit kan namelijk leiden tot storingen, oververhitting of een elektrische schok.

Wanneer u per ongeluk water of een andere vloeistof op het product morst, trek dan onmiddellijk de stekker van de netadapter uit het stopcontact. Veeg de vloeistof met een droge doek weg.

Vreemde objecten in het product kunnen leiden tot storingen. Wanneer vloeistof of een vreemd object in het product terechtkomt, moet u het gebruik direct staken en contact opnemen met een Nikon-vertegenwoordiger bij u in de buurt.

### 3. Het product verplaatsen

- De microscoop heeft handgrepen om het product te verplaatsen.  
Er bevinden zich twee handgrepen aan beide zijden van de voet van de microscoop en twee handgrepen aan de arm aan de achterzijde van de microscoop.  
Gebruik deze handgrepen bij het verplaatsen van de microscoop.
- De opslagruimte aan de achterkant van de microscoop is géén handgreep. Deze ruimte is bedoeld voor het opbergen van de lichtnetadapter en het netsnoer. Houd de microscoop tijdens het verplaatsen niet aan dit gedeelte vast.
- Wanneer u de microscoop verplaatst, moet u deze niet bij de instelknoppen, het oculair, het platform, enzovoort vasthouden. Deze onderdelen kunnen losraken en leiden tot storingen.

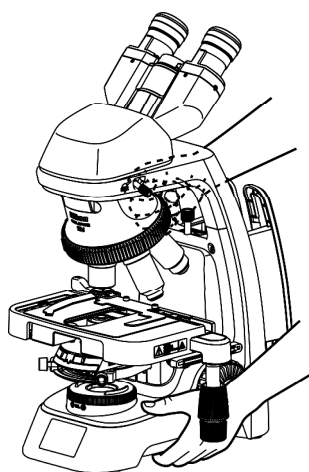
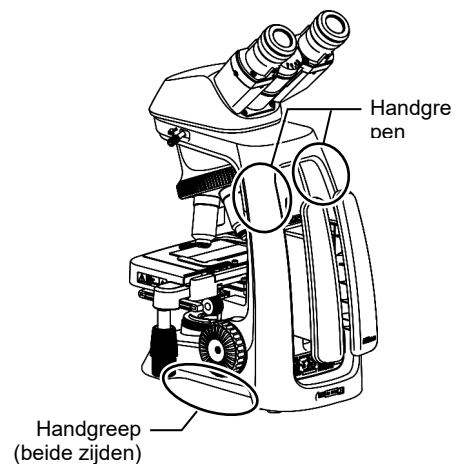

Houd twee handgrepen vast.

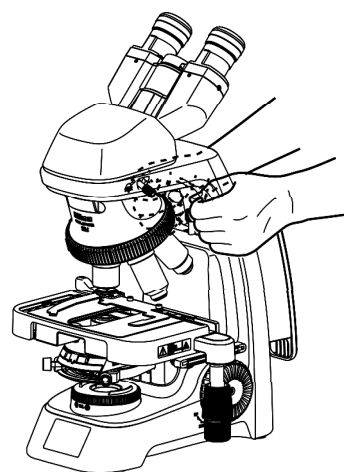

Houd de handgrepen vast.

### 4. De microscoop afvoeren



Om biologisch gevaar te vermijden, moet de microscoop worden verwijderd als verontreinigde apparatuur volgens de standaardprocedures van uw faciliteit.

## Sikkerhedsforanstaltninger

Selvom dette produkt er designet og fremstillet til at være helt sikkert under brug, kan forkert brug eller manglende overholdelse af de medfølgende sikkerhedsanvisninger forårsage personskade eller tingsskade. Læs denne vejledning omhyggeligt, før du bruger produktet, for at sikre korrekt brug. Denne vejledning må ikke kasseres, og den skal opbevares, så den altid er tilgængelig.

### Betydning af symboler anvendt på produktet

Symboler, der vises på produktet, angiver, at der altid er behov for forsigtighed under brug. Se altid i brugervejledningen, og læs de relevante instruktioner inden håndtering af de dele, som symbolet er påsat.

| Symbol  | Indhold  |
|---|--|
|    | <p><b>Miljøfare</b></p> <p>Dette symbol findes på hoveddelen til mikroskopets krydsbord (på håndtagets side af krydsbordet) og advarer om følgende:</p> <ul style="list-style-type: none"> <li>• ADVARSEL: Produktet kan udgøre en fare for miljøet, hvis der spildes en prøve på produktet.</li> <li>• Undgå at berøre forurenede dele med bare hænder for at undgå smittefare.</li> <li>• Desinficer de forurenede dele i henhold til standardprocedurerne på stedet.</li> </ul>   |
|  | <p><b>ADVARSEL (fotobiologisk sikkerhed)</b></p> <p>Dette symbol findes på mikroskopets hoveddel (på håndtagets side af krydsbordet) og advarer om følgende:</p> <ul style="list-style-type: none"> <li>• Fotobiologisk sikkerhedsklassificering af risikogruppe for diaskopisk belysning</li> <li>• Se ikke ind i diaskopisk belysning.</li> </ul> <p>For yderligere oplysninger, se  ADVARSEL, "7. Fotobiologisk sikkerhed" og "8. Se ikke ind i belysningsprofilen."</p> |

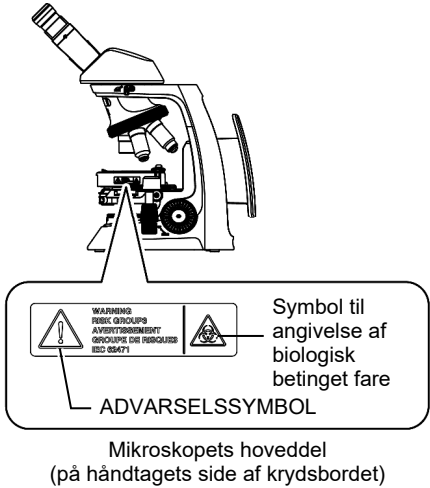



Symbol til angivelse af biologisk betinget fare

ADVARSELSSYMBOL

Mikroskopets hoveddel (på håndtagets side af krydsbordet)

### Symbolerne ADVARSEL og FORSIGTIG

Sikkerhedsanvisningerne i denne vejledning er mærket med følgende symboler for at fremhæve vigtigheden af dem. Af hensyn til din sikkerhed skal du altid følge de anvisninger, der er markeret med disse symboler.

| Symbol   | Indhold  |
|--|--|
|  <b>ADVARSEL</b>  | Hvis de anvisninger, der er markeret med dette symbol, ignoreres, kan det medføre alvorlig personskade eller dødsfald. |
|  <b>FORSIGTIG</b> | Hvis de anvisninger, der er markeret med dette symbol, ignoreres, kan det medføre personskade eller tingsskade.        |

**ADVARSEL****1. Skil ikke produktet ad.**

Hvis dette produkt skilles ad, kan det medføre elektrisk stød eller fejlfunktion. Fejl og skader som følge af demontering er ikke dækket af garantien. Demonter ikke nogen del, medmindre du bliver bedt om det i denne vejledning. Hvis du oplever problemer med produktet, skal du kontakte din nærmeste Nikon-repræsentant.

**2. Læs instruktionerne grundigt.**

For at sikre sikkerheden skal du læse denne vejledning samt vejledninger til andet udstyr, der skal bruges sammen med dette produkt, grundigt igennem. Sørg især for at følge advarslerne og advarslerne i begyndelsen af vejledningerne.

**3. Indgangsspænding, AC-adapter, netledning**

AC-adapteren til strømforsyning af dette produkt kan bruges med 100 til 240 VAC ved 50 til 60 Hz. Brug kun den vekselstrømsadapter og netledning, der er angivet i "Chapter 7 Specifications." Brug af en anden vekselstrømsadapter eller netledning kan medføre fejlfunktion eller brand.

- Undgå at bruge produktet i et miljø, hvor forsyningsspændingen kan svinge meget.
- Vekselstrømsadapteren til dette produkt er klassificeret som Klasse I mht. beskyttelse mod elektrisk stød. Sørg for at slutte det til en beskyttende jordklemme.
- Hvis vekselstrømsadapteren er tildækket, eller der er placeret genstande på vekselstrømsadapteren, kan det hindre varmeafledning, så produktet bliver unormalt varmt.

**4. Håndtering af brændbare opløsningsmidler**

Følgende brændbare opløsningsmidler anvendes sammen med produktet:

- Immersionsolie (Nikon-immersionsolie til objektiver, der skal nedsænkes i olie)
- Ren alkohol (ætylalkohol eller metylalkohol til rengøring af optiske dele)
- Petroleumbenzin (til aftørring af immersionsolien)
- Medicinsk alkohol (til desinfektion af mikroskopet)

Der må aldrig være åben ild i nærheden af disse opløsningsmidler. Ved brug af et opløsningsmiddel skal du sikre korrekt og sikker brug ved at læse instruktionerne fra producenten af opløsningsmidlet grundigt.

Når du bruger et opløsningsmiddel sammen med dette produkt, skal du overholde følgende forholdsregler:

- Hold opløsningsmidler væk fra produktet og dets omgivelser, når du sætter AC-adapteren eller netledningen i eller tager den ud.
- Pas på ikke at spilde opløsningsmidlerne.

**5. Farlige prøver**

Mikroskopet er primært til brug ved mikroskopisk observation af en prøve af f.eks. celler og væv anbragt på et objektglas.

Ved håndtering af en prøve skal det kontrolleres, om prøven er farlig. Håndter farlige prøver i henhold til standardproceduren for dit laboratorium. Hvis prøven er smitsom, skal du bære gummihandsker for at undgå infektion og undgå at røre ved prøven.

Hvis en sådan prøve kommer i kontakt med mikroskopet, skal den forurenede del desinficeres i henhold til standardproceduren for dit laboratorium.



## ADVARSEL

### 6. Bemærkninger om betjening af skyderne på kondensatordelen

En skyder til mikroskopi har to indstillede positioner. Den er fastgjort til kondensatordelen og bruges til at skifte observationsmetoder eller forstørrelser ved at ændre den indstillede position. Det klare lys kan nå okularrøret, når du flytter skyderen for at ændre den indstillede position.

Se ikke ind i den binokulære del, eller sluk for den diaskopiske belysning, når du betjener en skyder.

Især i diaskopisk fluorescensmikroskopi anvendes den meget klare belysning, så de intense udladninger kan nå okularrøret, når du betjener skyderen.

### 7. Fotobiologisk sikkerhed

Dette produkt er designet og fremstillet i overensstemmelse med sikkerhedsstandarden IEC 62471 "Fotobiologisk sikkerhed for lamper og lampesystemer".

Belysning nær krydsbordet og lys fra den binokulære del af okularrøret eller undervisningshovedet, og lys fra kameraporten på det trinokulære okularrør klassificeres i følgende risikogruppe. Afstanden (risikoafstanden) fra området omkring krydsbordet eller fra den binokulære del af okularrøret eller undervisningshovedet, eller fra kameraportens åbning, hvor risikogruppeklassifikationen svarer til den undtagelsesgruppe, der ikke forårsager fotobiologisk skade, er som anført herunder.

|  | Klassificering af risikogruppe | Risikoafstand |
|--|--------------------------------|---------------|
| <b>Fare for nethinden i forbindelse med blålys</b> | Risikogruppe 3                 | 36 m          |
| <b>Infrarød stråling er farlig for øjnene</b>      | Risikogruppe 3                 | 127 m         |

Belysning i risikogruppe 3 kan være farligt. Vær opmærksom på lysstyrkejustering ved hjælp af lysstyrkereguleringen, og undgå at se ind i stærkt lys i lang tid.

- LED-lyskilden er indbygget i mikroskopets nederste del. Belysningen fra feltlinsens lys går gennem kondensatoren og oplyser prøven. Se ikke direkte ind i kondensatorens linse, prøve eller prøvens periferi, og se ikke ind i feltlinsen.
- Se ikke ind i stærkt lys fra den binokulære del af okularrøret eller undervisningshovedet.
- Fjern ikke okularerne fra den binokulære del, når belysningen er tændt.
- Se ikke ind i stærkt lys fra kameraporten lige ovenfra.
- Når kameraet ikke er tilsluttet, skal du sætte det medfølgende dæksel på kameraporten.

**ADVARSEL****8. Se ikke ind i belysningsprofilen.**

Følgende advarselmærkat, der angiver den største risiko (risikogruppe 3) for fotobiologisk sikkerhed, er påsat på håndtagets side af krydsbordet for at minde brugeren om følgende forholdsregler. (For placeringen af denne mærkat, se figuren i "Chapter 1 Nomenclature of Each Part.")

**ADVARSEL (risikogruppe 3)**

Der udsendes IR og muligvis farligt lys fra kameraporten, når det trinokulære okularrør anvendes.

Se aldrig ind i kameraporten.

**FORSIGTIG (risikogruppe 2)**

Der udsendes muligvis farligt lys fra kondensatorens linse, når der anvendes diaskopisk belysning.

Se ikke på det udsendte lys. Det kan være skadeligt for øjnene.

**BEMÆRK (risikogruppe 1)**

Der udsendes muligvis farligt lys fra okularlinserne, når der anvendes diaskopisk belysning. Undgå langvarig mikroskopisk observation med stærk belysning.



## FORSIGTIG

### 1. Samling af mikroskopet

- Saml mikroskopet, mens AC-adapteren ikke er tilsluttet det.
- Pas på ikke at få fingre og hænder i klemme.

### 2. Gør ikke produktet vådt, og sørg for, at der ikke trænger fremmedlegemer ind.

Lad ikke produktet blive vådt, da det kan medføre funktionsfejl, overophedning eller elektrisk stød. Hvis der ved et uheld spildes vand eller andre væsker på produktet, skal netledningen straks tages ud af vekselstrømsadapteren. Tør derefter væsken af med en tør klud.

Indrængen af fremmedlegemer kan også medføre fejlfunktion. Hvis der kommer væske eller fremmedlegemer ind i produktet, skal du ophøre med at bruge produktet og kontakte den nærmeste Nikon-repræsentant.

### 3. Flytning af produktet

- Mikroskopet har holdeanordninger og håndtag. Der er to holdeanordninger på hver side af basen og to håndtag på bagsiden af mikroskopets arm. Når mikroskopet bæres, skal der holdes fast i disse holdeanordninger og håndtag.
- Opbevaringsdelen på bagsiden af mikroskopet er ikke et håndtag. Hold ikke på denne del, da den indeholder vekselstrømsadapteren og netledningen.
- Når du flytter produktet, må du ikke holde fast i fokuseringsknapper, okularrør og krydsbord osv. Delene kan løsne sig og medføre funktionsfejl.

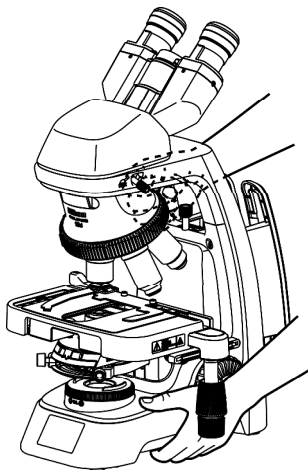
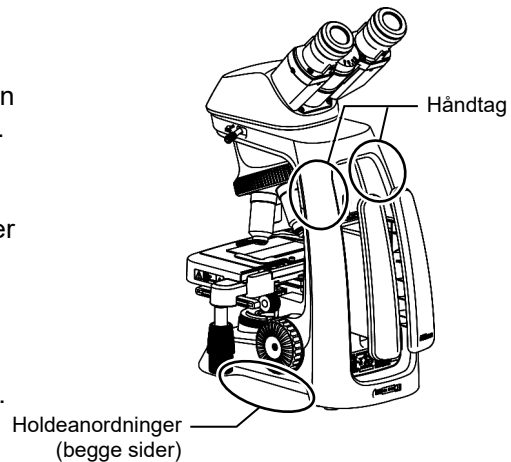

Tag fat i et håndtag og en holdeanordning.

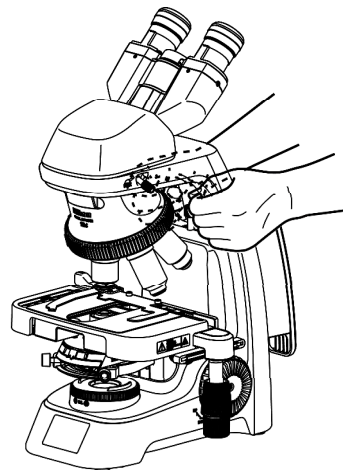

Hold fast i håndtagene.

### 4. Bortskaffelse af mikroskopet



For at undgå risici af miljømæssig karakter skal mikroskopet bortskaffes som forurennet udstyr i henhold til standardprocedurerne på stedet.

## Precauções de segurança

Apesar de este produto ser concebido e fabricado para ser totalmente seguro durante a utilização, a utilização incorreta ou o incumprimento das instruções de segurança fornecidas pode causar ferimentos pessoais ou danos materiais. Para garantir uma utilização correta, leia este manual cuidadosamente antes de utilizar o produto. Não deite fora este manual e mantenha-o à mão para uma consulta fácil.

### Significado dos símbolos utilizados no produto



Os símbolos que aparecem no produto indicam a necessidade de cuidado constante durante a utilização. Consulte sempre o manual de instruções e leia as instruções relevantes antes de manipular qualquer peça na qual o símbolo tenha sido afixado.

| Símbolo   | Conteúdo  |
|---|---|
|    | <p><b>Risco biológico</b></p> <p>Este símbolo pode ser encontrado na platina do corpo do microscópio (lado de manuseamento da platina) e obriga a ter em atenção o seguinte:</p> <ul style="list-style-type: none"> <li>• AVISO: O produto pode tornar-se um risco biológico se for derramada uma amostra sobre o produto.</li> <li>• Para evitar a exposição a riscos biológicos, não toque nas peças contaminadas com as mãos desprotegidas.</li> <li>• Descontamine as peças contaminadas de acordo com os procedimentos padrão das suas instalações.</li> </ul>                                     |
|  | <p><b>AVISO (segurança fotobiológica)</b></p> <p>Este símbolo pode ser encontrado no corpo do microscópio (lado de manuseamento da platina) e obriga a ter em atenção o seguinte:</p> <ul style="list-style-type: none"> <li>• Classificação do grupo de risco em termos de segurança fotobiológica da iluminação diascópica</li> <li>• Não olhe para a iluminação diascópica.</li> </ul> <p>Para mais informações, consulte o AVISO , "7. Segurança fotobiológica" e "8. Não olhe para a secção de iluminação".</p> |



### Símbolos de AVISO e de CUIDADO

As instruções de segurança neste manual estão assinaladas com os seguintes símbolos para realçar a sua importância. Para sua segurança, siga sempre as instruções assinaladas com estes símbolos.

| Símbolo  | Conteúdo   |
|--|--|
|  <b>AVISO</b>   | O não cumprimento das instruções assinaladas com este símbolo pode provocar ferimentos graves ou morte.    |
|  <b>CUIDADO</b> | O não cumprimento das instruções assinaladas com este símbolo pode provocar ferimentos ou danos materiais. |

**AVISO****1. Não desmonte.**

A desmontagem deste produto pode resultar em choques elétricos ou avarias. Avarias e danos resultantes da desmontagem não serão cobertos pela garantia. Não desmonte nenhuma peça, a menos que seja instruído para o fazer neste manual. Se tiver problemas com o produto, contacte o representante da Nikon mais próximo.

**2. Leia atentamente as instruções.**

Para garantir a segurança, leia atentamente este manual e os manuais de outro equipamento a utilizar com este produto. Em particular, certifique-se de que segue os avisos e as advertências no início dos manuais.

**3. Tensão de entrada, adaptador CA, cabo de alimentação**

O adaptador CA para fornecer energia a este produto pode ser utilizado com 100 a 240 V CA a 50 a 60 Hz. Utilize apenas o adaptador CA e o cabo de alimentação especificados no "Chapter 7 Specifications". A utilização de outro adaptador CA ou cabo de alimentação pode resultar em avarias ou incêndio.

- Evite utilizar o produto num ambiente em que a tensão de alimentação possa flutuar excessivamente.
- O adaptador CA deste produto está classificado como Classe I para proteção contra choques elétricos. Certifique-se de que o liga a um terminal de terra de proteção.
- Se o adaptador CA estiver coberto ou se forem colocados itens no adaptador CA, a dissipação de calor pode ser dificultada, fazendo com que fique anormalmente quente.

**4. Manuseamento de solventes inflamáveis**

Os seguintes solventes inflamáveis são utilizados com o produto:

- Óleo de imersão (óleo de imersão Nikon para objetivas de imersão em óleo)
- Álcool absoluto (álcool etílico ou álcool metílico para a limpeza de peças óticas)
- Benzina de petróleo (para limpar o óleo de imersão)
- Álcool medicinal (para desinfetar o microscópio)

Nunca segure uma chama perto destes solventes. Ao utilizar um solvente, certifique-se de que o utiliza de forma correta e segura através da leitura cuidadosa das instruções fornecidas pelo fabricante do solvente.

Ao utilizar um solvente com este produto, respeite as seguintes precauções:

- Mantenha os solventes afastados do produto e da área circundante quando ligar/desligar o adaptador CA ou o cabo de alimentação.
- Tenha cuidado para não derramar os solventes.

**5. Amostras perigosas**

Este microscópio destina-se principalmente a ser utilizado na observação microscópica de uma amostra, como células e tecido afixados numa lâmina.

Ao manusear uma amostra, verifique se esta é perigosa. Deve manusear as amostras perigosas de acordo com o procedimento padrão para o seu laboratório. Se a amostra for de natureza infecciosa, use luvas de borracha para evitar infeções e tenha cuidado para não tocar numa amostra.

Se uma amostra deste tipo entrar em contacto com o microscópio, descontamine a parte contaminada de acordo com o procedimento padrão para o seu laboratório.



**AVISO****6. Notas sobre o funcionamento dos manípulos no condensador**

Um manípulo para microscopia tem duas posições definidas. Está fixo ao condensador e é utilizado para alterar os métodos de observação ou as ampliações através da modificação da posição definida. A luz brilhante pode alcançar o tubo da ocular quando move o manípulo para alterar a posição definida.

Afastese das oculares ou desligue a iluminação diascópica quando utilizar um manípulo.

A iluminação extremamente brilhante é utilizada, principalmente, em microscopia de fluorescência diascópica, pelo que os flashes intensos podem alcançar o tubo da ocular durante a utilização do manípulo.

**7. Segurança fotobiológica**

Este produto foi concebido e fabricado de acordo com a norma de segurança IEC 62471 "Segurança fotobiológica de lâmpadas e sistemas de lâmpadas".

A iluminação próxima da platina e a luz da parte binocular do tubo da ocular ou da cabeça do microscópio, bem como a luz da porta da câmara do tubo da ocular trinocular são classificadas no grupo de risco seguinte. A distância (distância de perigo) da proximidade da platina, da parte binocular do tubo da ocular ou da cabeça do microscópio ou da abertura da porta da câmara, onde a classificação do grupo de risco é equivalente ao grupo isento que não provoca lesões fotobiológicas, é a seguinte.

|   | <b>Classificação do grupo de risco</b> | <b>Distância de perigo</b> |
|---|--|----------------------------|
| <b>Perigo de luz azul retinal</b>                     | Grupo de risco 3                       | 36 m                       |
| <b>Perigo de radiação infravermelha para os olhos</b> | Grupo de risco 3                       | 127 m                      |

A iluminação no grupo de risco 3 pode ser perigosa. Preste atenção ao ajuste do brilho através do botão de controlo do brilho e evite olhar para uma luz forte durante muito tempo.

- A fonte de luz LED está incorporada na parte inferior do microscópio. A luz de iluminação da lente de campo atravessa o condensador e ilumina a amostra. Não olhe para a lente do condensador, para a amostra ou para a periferia da amostra, nem olhe para a lente de campo.
- Não olhe para uma luz forte proveniente da parte binocular do tubo da ocular ou da cabeça do microscópio.
- Não retire as oculares da parte binocular quando a iluminação estiver ligada.
- Não olhe diretamente para a luz forte a partir da porta da câmara por cima.
- Quando não encaixar a câmara, coloque a tampa fornecida na porta da câmara.

 **AVISO**

**8. Não olhe para a secção de iluminação.**

A seguinte etiqueta de aviso, que indica o risco mais elevado (Grupo de risco 3) para a segurança fotobiológica, está afixada no lado de manuseamento da platina para lembrar o utilizador das seguintes precauções. (Para obter as localizações desta etiqueta, consulte a figura em "Chapter 1 Nomenclature of Each Part".)



**AVISO (Grupo de risco 3)**

É emitida uma luz por infravermelhos e uma luz possivelmente perigosa a partir da porta da câmara quando o tubo da ocular trinocular é utilizado.

Nunca olhe para a porta da câmara.

**ATENÇÃO (Grupo de risco 2)**

É emitida uma luz possivelmente perigosa a partir da lente do condensador quando é utilizada a iluminação diascópica.

Não olhe para a luz emitida. Pode ser prejudicial para os olhos.

**ADVERTÊNCIA (Grupo de risco 1)**

É emitida uma luz possivelmente perigosa a partir das lentes da ocular quando é utilizada a iluminação diascópica.

Evite uma observação microscópica prolongada com iluminação forte.



## CUIDADO

### 1. Montagem do microscópio

- Monte o microscópio enquanto o adaptador CA não estiver ligado ao mesmo.
- Tenha cuidado para evitar entalar os dedos e as mãos.

### 2. Não molhe o produto nem permita a entrada de materiais estranhos.

Não deixe que o produto se molhe, pois isso pode resultar em avarias, sobreaquecimento ou choque elétrico.

Em caso de derrame acidental de água ou de outros líquidos sobre o produto, desligue imediatamente o cabo de alimentação do adaptador CA. Em seguida, limpe o líquido com um pano seco.

A entrada de materiais estranhos também pode resultar em avarias. Se entrarem líquidos ou materiais estranhos no produto, deixe de utilizar o produto e contacte o representante da Nikon mais próximo.

### 3. Mover o produto

- O microscópio tem pegas e pegas de transporte. Existem duas pegas em ambos os lados da base e duas pegas no braço da parte posterior do microscópio. Ao transportar o microscópio, segure-o firmemente com estas pegas.
- A parte de armazenamento na parte de trás do microscópio não é uma pega. Não segure esta peça, pois ela serve para guardar o adaptador CA e o cabo de alimentação.
- Ao mover o produto, não o segure pelos botões de focagem, pelo tubo da ocular e pela platina, etc. As peças podem soltar-se e isso também pode provocar avarias.

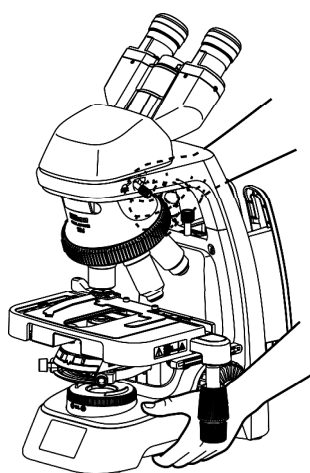
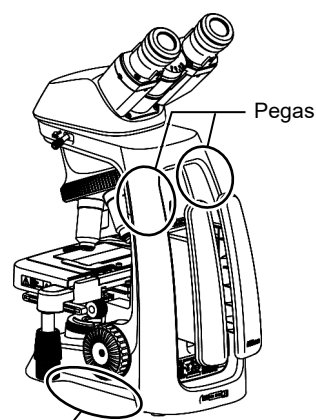

Segure numa pega e numa pega de transporte.

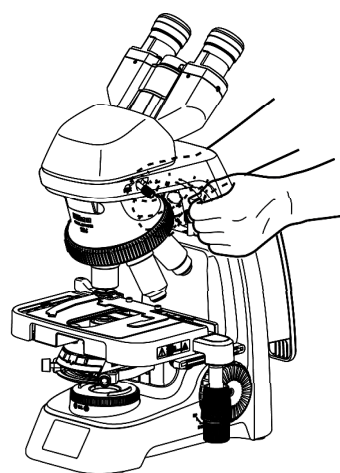

Segure nas pegas.

### 4. Eliminação do microscópio



Para evitar riscos biológicos, elimine o microscópio como equipamento contaminado, de acordo com os procedimentos padrão das suas instalações.

## Turvatoimet

Vaikka tämä tuote on suunniteltu ja valmistettu täysin käyttöturvalliseksi, sen virheellinen käyttö tai turvallisuusohjeiden laiminlyönti voi johtaa henkilövahinkoihin tai aineellisiin vahinkoihin. Oikeanlaisen käytön varmistamiseksi tämä opas on luettava huolellisesti ennen tuotteen käyttöä. Opas on myös säilytettävä ja pidettävä helposti saatavilla.

### Tuotteessa olevien symbolien selitykset

Tuotteeseen merkityt symbolit osoittavat, että varovaisuutta tarvitaan koko käytön ajan. Ennen kuin käsitellään symbolilla merkittyä tuotteen osaa, käyttöoppaasta on luettava sitä koskevat ohjeet.

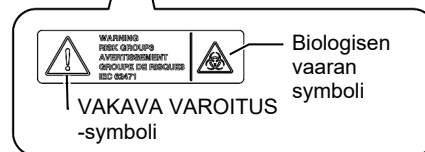
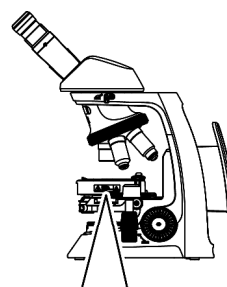

| Symboli   | Sisältö   |
|---|---|
|    | <p><b>Biologinen vaara</b></p> <p>Tämä symboli sijaitsee mikroskoopin rungon näytepöydässä (näytepöydän kahvan reunassa) ja ilmaisee seuraavan vaaran.</p> <ul style="list-style-type: none"> <li>• <b>VAKAVA VAROITUS:</b> jos tuotteeseen läikkyä näytettä, se voi muuttua biologisesti vaaralliseksi.</li> <li>• Altistumisen välttämiseksi kontaminoituneita osia ei saa koskettaa paljain käsin.</li> <li>• Kontaminoituneet osat on puhdistettava laitoksen normaalien menettelytapojen mukaisesti.</li> </ul>  |
|  | <p><b>VAKAVA VAROITUS (fotobiologinen turvallisuus)</b></p> <p>Tämä symboli sijaitsee mikroskoopin rungossa (näytepöydän kahvan reunassa) ja ilmaisee seuraavan vaaran.</p> <ul style="list-style-type: none"> <li>• Diaskoopin valaistuksen fotobiologisen turvallisuuden riskiryhmäluokitus</li> <li>• Älä katso diaskoopin valaistukseen.</li> </ul> <p>Lisätietoja on kohdassa  <b>VAKAVA VAROITUS, 7.</b> Fotobiologinen turvallisuus ja 8. Älä katso valaistusosaan.</p> |



Mikroskoopin runko  
(näytepöydän kahvan reuna)

### VAKAVA VAROITUS- ja VAROITUS-symbolit

Tässä käyttöoppaassa turvallisuusohjeiden tärkeyttä on korostettu merkitsemällä ne seuraavilla symboleilla. Turvallisuuden varmistamiseksi näillä symboleilla merkityjä ohjeita on aina noudatettava.

| Symboli  | Sisältö  |
|--|--|
|  <b>VAKAVA VAROITUS</b> | Tällä symbolilla merkittyjen ohjeiden laiminlyönti voi johtaa vakavaan henkilövahinkoon tai kuolemaan.     |
|  <b>VAROITUS</b>        | Tällä symbolilla merkittyjen ohjeiden laiminlyönti voi johtaa henkilövahinkoon tai aineelliseen vahinkoon. |

**VAKAVA  
VAROITUS**
**1. Ei saa purkaa.**

Tuotteen purkaminen voi aiheuttaa sähköiskun tai toimintahäiriön. Purkamisesta aiheutuvat toimintahäiriöt ja vauriot eivät kuulu tuotetakuun piiriin. Mitään osaa ei saa purkaa, paitsi jos tässä oppaassa erityisesti kehotetaan tekemään niin. Jos tuoteongelmia ilmenee, on otettava yhteys lähimpään Nikonin edustajaan.

**2. Ohjeet on luettava huolellisesti.**

Turvallisuuden varmistamiseksi käyttäjän on luettava huolellisesti tämä käyttöopas ja tuotteen yhteydessä käytettävien muiden laitteiden käyttöoppaat. Erityistä huomiota on kiinnitettävä oppaiden alussa annettujen vakavien varoitusten ja varoitusten noudattamiseen.

**3. Tulojännite, vaihtovirtasovitin, virtajohto**

Tuotteen virransyöttöön tarkoitettua vaihtovirtasovitinta voidaan käyttää, kun verkkovirran jännite on 100–240 VAC ja taajuus 50–60 Hz. Tuotteen kanssa saa käyttää vain vaihtovirtasovitinta ja virtajohtoa, jotka on mainittu luvussa Chapter 7 Specifications. Muiden sovitimien tai johtojen käyttö voi aiheuttaa toimintahäiriön tai tulipalon.

- Vältä tuotteen käyttöä ympäristössä, jossa tulojännite voi vaihdella voimakkaasti.
- Tämän tuotteen vaihtovirtasovitin on luokiteltu suojausluokkaan I sähköiskulta suojaamisen suhteen. Varmista, että tuote on yhdistetty suojamaadoitusliitimeen.
- Jos vaihtovirtasovitin peitetään tai sen päälle asetetaan esineitä, lämmön haihtuminen voi estyä ja aiheuttaa sovitinien epätavallisen kuumenemisen.

**4. Syttyvien liuottimien käsittely**

Tuotteen yhteydessä käytetään seuraavia syttyviä liuottimia:

- immersioöljy (Nikon-immersioöljy öljyimmersio-objektiiveja varten)
- absoluuttinen alkoholi (etanoli tai metanoli optisten osien puhdistamista varten)
- petrolibensiini (immersioöljyn pois pyyhkimistä varten)
- lääkealkoholi (mikroskoopin desinfiointia varten).

Näiden liuottimien lähelle ei saa tuoda tulenliekkiä. Liuotinta käytettäessä sen valmistajan ohjeet on luettava huolellisesti. Näin varmistetaan tuotteen oikea ja turvallinen käyttö.

Käytettäessä liuotinta tämän tuotteen kanssa on noudatettava seuraavia varotoimia:

- Varmista, että tuotteen luona tai sen lähiympäristössä ei ole liuottimia, kun liität tai irrotat vaihtovirtasovittimen tai virtajohdon.
- Varo läikyttämästä liuottimia.

**5. Vaaralliset näytteet**

Tätä mikroskooppia käytetään pääasiassa objektilasille kiinnitetyn näytteen, kuten solujen tai kudoksen, mikroskooppiseen tarkasteluun.

Näytettä käsiteltäessä on tarkistettava, onko näyte mahdollisesti vaarallinen. Vaarallisia näytteitä on käsiteltävä laboratorion normaalien menettelytapojen mukaisesti. Jos näyte on tartuntavaarallinen, tartunnan välttämiseksi on käytettävä kumikäsineitä ja varottava koskemasta näytettä.

Jos tällainen näyte joutuu kosketuksiin mikroskoopin kanssa, kontaminoinut osa on puhdistettava laboratorion normaalien menettelytapojen mukaisesti.

**6. Huomautuksia näytelasien käytöstä kondensoriosassa**

Mikroskopianäytelasille on kaksi asentoa. Se kiinnitetään kondensoriosaan ja sitä käytetään vaihdettaessa tarkastelumenetelmiä tai suurennuksia vaihtamalla asetettua asentoa. Kirkas valo saattaa päästä okulaariputkeen, kun siirät näytelasia vaihtaessasi asetettua asentoa.

Irrota katseesi binokulaareista tai sammuta diaskooppinen valaistus käyttäessäsi näytelasia.

Erityisesti diaskooppisessa fluoresenssimikroskopiassa käytetään äärimmäisen kirkasta valaistusta, joten voimakkaita välähdyksiä saattaa päästä okulaariputkeen käytettäessä näytelasia.

**VAKAVA  
VAROITUS**
**7. Fotobiologinen turvallisuus**

Tämän tuotteen suunnittelussa ja valmistuksessa on noudatettu turvallisuusstandardia IEC 62471 Lamppujen ja lamppujärjestelmien fotobiologinen turvallisuus.

Näytepöydän lähivalaistus ja okulaariputken binokulaariosasta tai opetuskannasta tuleva valo ja trinokulaariputken kameraportista tuleva valo on luokiteltu seuraavassa esitettyyn riskiryhmään. Seuraava etäisyys (vaaraetäisyys) näytepöydästä tai okulaariputken binokulaariosasta tai opetuskannasta tai kameraportin aukosta on säilytettävä, jotta riskiryhmäluokitus vastaa fotobiologisesti haitattoman valon ryhmäluokitusta:

|   | Riskiryhmäluokitus | Vaaraetäisyys |
|---|--------------------|---------------|
| <b>Sinisen valon aiheuttama vaara verkkokalvoille</b> | Riskiryhmä 3       | 36 m          |
| <b>Infrapunasäteiden vaara silmille</b>               | Riskiryhmä 3       | 127 m         |

Riskiryhmään 3 luokiteltu valaistus voi olla vaarallista. Huomioi kirkkauden säätäminen säätönupin avulla ja vältä pitkäaikaista katsomista kirkaaseen valoon.

- LED-valolähde on mikroskoopin alaosassa. Kenttälinssin valo kulkee kondensorin läpi ja valaisee näytteen. Älä tuijota kondensorin linssiin, näytteeseen tai näytteen reunaan äläkä katso kenttälinssiin.
- Älä katso okulaariputken binokulaariosasta tai opetuskannasta tulevaan voimakkaaseen valoon.
- Älä irrota okulaareja binokulaariosasta, kun valaistus on käytössä.
- Älä katso kameraportista tulevaa voimakasta valoa ylhäältä päin.
- Jos tuotteeseen ei asenneta kameraa, kameraporttiin on asetettava tuotteen mukana toimitettu korkki.

**8. Älä katso valaistusosaan.**

Seuraava fotobiologisen turvallisuuden korkeimmasta riskistä (riskiryhmä 3) kertova varoitustarra on kiinnitetty näytepöydän kahvan reunaan muistuttamaan käyttäjää seuraavista varoitoimista. (Tarran sijainti näytetään kuvassa kohdassa "Chapter 1 Nomenclature of Each Part.")

**VAKAVA VAROITUS (riskiryhmä 3)**

Kameraportista tulee infrapunasäteitä ja mahdollisesti vaarallista valoa käytettäessä trinokulaarista putkea.

Älä koskaan katso kameraporttiin.

**VAROITUS (riskiryhmä 2)**

Kondensorin linssistä tuleva valo on mahdollisesti vaarallista käytettäessä diaskoopista valaistusta.

Älä tuijota lähetettyä valoa. Se voi olla haitallista silmille.

**TÄRKEÄÄ (riskiryhmä 1)**

Okulaarien linseistä tulee mahdollisesti vaarallista valoa käytettäessä diaskoopista valaistusta.

Vältä mikroskoopin pitkäaikaista käyttöä voimakkaalla valaistuksella.



## VAROITUS

### 1. Mikroskoopin kokoaminen

- Kun kokoat mikroskooppia, vaihtovirtasovitin ei saa olla liitettynä siihen.
- Varo sormien ja käsien joutumista puristuksiin osien väliin.

### 2. Suojele tuote kastumiselta ja vierasesineiden sisäänpääsylvä.

Tuote on suojeltava kastumiselta. Kastuminen voi aiheuttaa toimintahäiriön, ylikuumentumisen tai sähköiskun.

Jos tuotteeseen läikkyä vahingossa vettä tai muuta nestettä, irrota heti virtajohto vaihtovirtasovittimesta. Pyyhi sitten neste pois kuivalla liinalla.

Myös vierasesineiden pääsy tuotteen sisään voi aiheuttaa toimintahäiriön. Jos tuotteen sisään joutuu nestettä tai vierasesine, lopeta tuotteen käyttö ja ota yhteys lähimpään Nikonin edustajaan.

### 3. Tuotteen siirtäminen

- Mikroskoopissa on kädensijat ja kahvat kantamista varten. Jalustassa on kaksi kädensijaa, ja mikroskoopin taustapuolen varressa on kaksi kahvaa. Mikroskooppia kannetaan pitämällä tukevasti kiinni näistä kädensijoista tai kahvoista.
- Sen sijaan mikroskoopin takaosassa oleva säilytysosa ei ole kahva. Siitä ei saa pitää kiinni, koska se on vaihtovirtasovittimen ja virtajohtosäilytyspaikka.
- Kun siirrät tuotetta, älä pidä kiinni esimerkiksi tarkennusnupeista, okulaariputkesta tai näytepöydästä. Nämä osat voivat irrota, ja seurauksena voi olla myös toimintahäiriöitä.

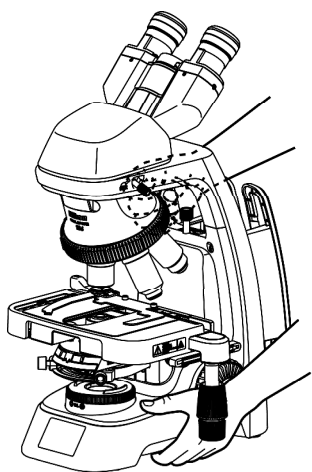
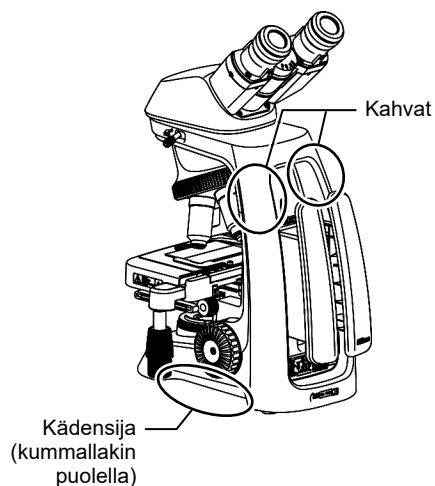

Pidä kiinni kahvoista ja kädensijasta.

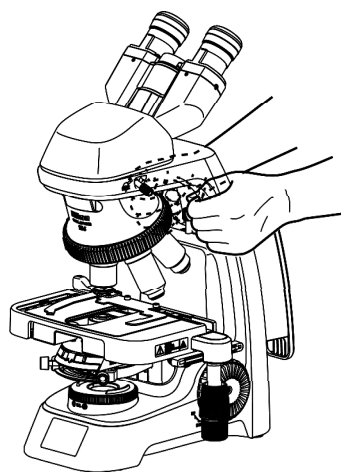

Pidä kiinni kahvoista.

### 4. Mikroskoopin hävittäminen



Biologisten vaarojen välttämiseksi mikroskooppi on hävitettävä noudattamalla kontaminoituneita laitteita koskevia laitoksen normaaleja menettelytapoja.

## Προφυλάξεις ασφαλείας

Παρόλο που αυτό το προϊόν έχει σχεδιαστεί και κατασκευαστεί για να σας παρέχει απόλυτη ασφάλεια κατά τη χρήση, τυχόν λανθασμένη χρήση ή αμέλεια των οδηγιών ενδέχεται να προκαλέσουν προσωπικό τραυματισμό ή ζημία. Για να εξασφαλιστεί η σωστή χρήση, διαβάστε προσεκτικά αυτό το εγχειρίδιο οδηγιών πριν από τη χρήση του προϊόντος. Μην απορρίψετε το παρόν εγχειρίδιο αλλά φυλάξτε το κοντά στο προϊόν για να το συμβουλευέστε εύκολα.

### Ερμηνεία των συμβόλων που χρησιμοποιούνται στο προϊόν



Τα σύμβολα που εμφανίζονται επάνω στο προϊόν δείχνουν την ανάγκη για προσοχή ανά πάσα στιγμή κατά τη χρήση. Πάντα να συμβουλευέστε το εγχειρίδιο οδηγιών και να διαβάζετε τις σχετικές οδηγίες προτού να χειριστείτε οποιοδήποτε από τα τμήματα στα οποία έχει τοποθετηθεί το σύμβολο.

| Σύμβολο   | Περιεχόμενα   |
|---|---|
|    | <p><b>Βιολογικός κίνδυνος</b></p> <p>Αυτό το σύμβολο βρίσκεται στην πλάκα της βάσης του μικροσκοπίου (πλευρά λαβής της πλάκας) και εφιστά την προσοχή στα εξής:</p> <ul style="list-style-type: none"> <li>• ΠΡΟΕΙΔΟΠΟΙΗΣΗ: Εάν ένα δείγμα χυθεί στο προϊόν, το προϊόν ενδέχεται να γίνει βιολογικά επικίνδυνο.</li> <li>• Για την αποφυγή έκθεσης σε βιολογικό κίνδυνο, μην εγγίζετε το μολυσμένο τμήμα με γυμνά χέρια.</li> <li>• Απολυμάνετε το μολυσμένο τμήμα σύμφωνα με τις συνήθεις διαδικασίες για την εγκατάστασή σας.</li> </ul>  |
|  | <p><b>ΠΡΟΕΙΔΟΠΟΙΗΣΗ (φωτοβιολογική ασφάλεια)</b></p> <p>Αυτό το σύμβολο βρίσκεται στην πλάκα της βάσης του μικροσκοπίου (δεξιά πλευρά της πλάκας) και εφιστά την προσοχή στα εξής:</p> <ul style="list-style-type: none"> <li>• Ταξινόμηση ομάδων κινδύνου φωτοβιολογικής ασφάλειας του διασκοπτικού φωτισμού</li> <li>• Μην κοιτάζετε απευθείας τον διασκοπτικό φωτισμό.</li> </ul> <p>Για λεπτομέρειες, βλ.  ΠΡΟΕΙΔΟΠΟΙΗΣΗ, "7. Φωτοβιολογική ασφάλεια" και "8. Μην κοιτάζετε απευθείας στο τμήμα φωτισμού".</p> |



### Σύμβολα ΠΡΟΕΙΔΟΠΟΙΗΣΗΣ και ΠΡΟΦΥΛΑΞΗΣ

Στο παρόν εγχειρίδιο, οι οδηγίες ασφαλείας επισημαίνονται με τα ακόλουθα σύμβολα, για να τονιστεί η σπουδαιότητά τους. Για την ασφάλειά σας, ακολουθείτε πάντα τις οδηγίες που επισημαίνονται με αυτά τα σύμβολα.

| Σύμβολο  | Περιεχόμενα   |
|--|---|
|  <b>ΠΡΟΕΙΔΟΠΟΙΗΣΗ</b> | Η παράβλεψη των οδηγιών που επισημαίνονται με αυτό το σύμβολο ενδέχεται να οδηγήσει σε σοβαρό τραυματισμό ή θάνατο. |
|  <b>ΠΡΟΣΟΧΗ</b>       | Η παράβλεψη των οδηγιών που επισημαίνονται με αυτό το σύμβολο ενδέχεται να οδηγήσει σε τραυματισμό ή υλική ζημία.   |



**ΠΡΟΕΙΔΟΠΟΙΗΣΗ****1. Μην αποσυναρμολογείτε.**

Η αποσυναρμολόγηση ενδέχεται να προκαλέσει ηλεκτροπληξία ή/και δυσλειτουργία. Οι δυσλειτουργίες και οι ζημιές που προκύπτουν από την αποσυναρμολόγηση δεν θα καλύπτονται από την εγγύηση. Μην αποσυναρμολογείτε κανένα τμήμα εκτός εάν υπάρχει σχετική οδηγία στο παρόν εγχειρίδιο. Εάν αντιμετωπίσετε προβλήματα με το προϊόν, επικοινωνήστε με τον πλησιέστερο αντιπρόσωπο της Nikon.

**2. Διαβάστε προσεκτικά τις οδηγίες.**

Για να εξασφαλίσετε την ασφάλεια, διαβάστε προσεκτικά αυτό το εγχειρίδιο και τα εγχειρίδια για άλλον εξοπλισμό που πρόκειται να χρησιμοποιηθεί μαζί με αυτό το προϊόν. Συγκεκριμένα, βεβαιωθείτε ότι ακολουθείτε τις προειδοποιήσεις και τις συστάσεις προσοχής που αναφέρονται στην αρχή των εγχειριδίων.

**3. Τάση εισόδου, τροφοδοτικό AC, καλώδιο τροφοδοσίας**

Το τροφοδοτικό AC για την παροχή ρεύματος σε αυτό το προϊόν μπορεί να χρησιμοποιηθεί με 100 έως 240 V AC στα 50 έως 60 Hz. Χρησιμοποιείτε μόνο το τροφοδοτικό AC και το καλώδιο τροφοδοσίας που καθορίζονται στο "Chapter 7 Specifications". Η χρήση άλλου τροφοδοτικού AC ή καλωδίου τροφοδοσίας ενδέχεται να οδηγήσει σε δυσλειτουργία ή πυρκαγιά.

- Αποφεύγετε τη χρήση του προϊόντος σε περιβάλλον όπου η τάση τροφοδοσίας ενδέχεται να παρουσιάζει υπερβολικές διακυμάνσεις.
- Το τροφοδοτικό AC για αυτό το προϊόν είναι ταξινομημένο ως Τάξη I για προστασία από ηλεκτροπληξία. Βεβαιωθείτε ότι το συνδέετε σε προστατευτικό ακροδέκτη γείωσης.
- Εάν το τροφοδοτικό AC είναι καλυμμένο ή εάν υπάρχουν αντικείμενα τοποθετημένα επάνω στο τροφοδοτικό AC, ενδέχεται να εμποδιστεί ο διασκορπισμός θερμότητας και να προκληθεί μη φυσιολογική υπερθέρμανσή του.

**4. Χειρισμός εύφλεκτων διαλυτών**

Οι ακόλουθοι εύφλεκτοι διαλύτες χρησιμοποιούνται με το προϊόν:

- Έλαιο εμβάπτισης (έλαιο εμβάπτισης Nikon για αντικειμενικούς φακούς ελαίου εμβάπτισης)
- Απόλυτο οινόπνευμα (αιθυλική αλκοόλη ή μεθανόλη για τον καθαρισμό οπτικών τμημάτων)
- Βενζίνη πετρελαίου (για σκούπισμα του ελαίου εμβάπτισης)
- Ιατρικό οινόπνευμα (για απολύμανση του μικροσκοπίου)

Μην έχετε ποτέ φλόγα κοντά σε αυτούς τους διαλύτες. Όταν χρησιμοποιείτε διαλύτες, διασφαλίζετε τη σωστή και ασφαλή χρήση διαβάζοντας προσεκτικά τις οδηγίες που παρέχονται από τον κατασκευαστή του διαλύτη.

Όταν χρησιμοποιείτε διαλύτη με αυτό το προϊόν, τηρείτε τις ακόλουθες προφυλάξεις:

- Κρατήστε τους διαλύτες μακριά από το προϊόν και το περιβάλλον του όταν κατά τη σύνδεση/αποσύνδεση του τροφοδοτικού AC ή του καλωδίου τροφοδοσίας.
- Προσέχετε να μην χυθούν οι διαλύτες.

**5. Επικίνδυνα δείγματα**

Το παρόν μικροσκόπιο προορίζεται κυρίως για χρήση σε μικροσκοπική παρατήρηση δείγματος, όπως κутάρων και ιστού τοποθετημένων σε αντικειμενοφόρο πλάκα.

Κατά τον χειρισμό δείγματος, ελέγξτε για να καθορίσετε εάν το δείγμα είναι επικίνδυνο. Χειριστείτε τα επικίνδυνα δείγματα σύμφωνα με την τυπική διαδικασία για το εργαστήριό σας. Εάν το δείγμα είναι μολυσματικής φύσης, φορέστε ελαστικά γάντια για να αποφύγετε τη μόλυνση και προσέξτε να μην αγγίξετε το δείγμα.

Σε περίπτωση επαφής του δείγματος με το μικροσκόπιο, απολυμάνετε το μολυσμένο τμήμα σύμφωνα με την τυπική διαδικασία για το εργαστήριό σας.



## ΠΡΟΕΙΔΟΠΟΙΗΣΗ

### 6. Σημειώσεις για τον χειρισμό των αντικειμενοφόρων πλακών στο τμήμα του συμπυκνωτή

Μια αντικειμενοφόρος πλάκα για τη μικροσκοπική εξέταση έχει δύο καθορισμένες θέσεις. Στερεώνεται στο τμήμα του συμπυκνωτή και χρησιμοποιείται για την εναλλαγή των μεθόδων παρατήρησης ή των μεγεθύνσεων μέσω της αλλαγής της καθορισμένης θέσης. Το έντονο φως ενδέχεται να φτάσει στον σωλήνα προσοφθάλμιου φακού όταν μετακινείτε την αντικειμενοφόρο πλάκα για να αλλάξετε την καθορισμένη θέση.

Όταν χειρίζεστε μια αντικειμενοφόρο πλάκα, απομακρύνετε τα μάτια σας από τις διόπτρες ή απενεργοποιείτε τον διασκοπικό φωτισμό.

Ιδιαίτερα στη μικροσκοπική εξέταση διασκοπικού φθορισμού, ο πολύ έντονος διασκοπικός φωτισμός χρησιμοποιείται προκειμένου να υπάρχει περίπτωση οι έντονες λάμπεις να φτάσουν στον σωλήνα προσοφθάλμιου φακού όταν χειρίζεστε την αντικειμενοφόρο πλάκα.

### 7. Φωτοβιολογική ασφάλεια

Αυτό το προϊόν έχει σχεδιαστεί και κατασκευαστεί σύμφωνα με το πρότυπο ασφαλείας IEC 62471 "Φωτοβιολογική ασφάλεια λαμπτήρων και συστημάτων λαμπτήρων".

Ο φωτισμός κοντά στην πλάκα και το φως από το τμήμα των διόπτρων του σωλήνα προσοφθάλμιου φακού ή τη διδακτική κεφαλή, καθώς και το φως από τη θύρα της κάμερας του τριοφθάλμιου σωλήνα προσοφθάλμιου φακού ταξινομούνται στην ακόλουθη ομάδα κινδύνου. Η απόσταση (απόσταση κινδύνου) από την περιοχή κοντά στην πλάκα ή από το τμήμα των διόπτρων του σωλήνα προσοφθάλμιου φακού ή τη διδακτική κεφαλή ή από το άνοιγμα της θύρας της κάμερας, όπου η ταξινόμηση της ομάδας κινδύνου είναι ισοδύναμη με την απαλλασσόμενη ομάδα που δεν προκαλεί φωτοβιολογική βλάβη, είναι η ακόλουθη.

|   | Ταξινόμηση ομάδων κινδύνου | Απόσταση κινδύνου |
|---|----------------------------|-------------------|
| <b>Κίνδυνος για τον αμφιβληστροειδή από το μπλε φως</b> | Ομάδα κινδύνου 3           | 36 m              |
| <b>Κίνδυνος υπέρυθρης ακτινοβολίας για τα μάτια</b>     | Ομάδα κινδύνου 3           | 127 m             |

Ο φωτισμός στην ομάδα κινδύνου 3 μπορεί να είναι επικίνδυνος. Δώστε προσοχή στη ρύθμιση της φωτεινότητας με το κουμπί ελέγχου φωτεινότητας και αποφύγετε να κοιτάζετε απευθείας το έντονο φως για μεγάλο χρονικό διάστημα.

- Η πηγή φωτός LED είναι ενσωματωμένη στο κάτω τμήμα του μικροσκοπίου. Το φως από τον φακό πεδίου διέρχεται από τον συμπυκνωτή και φωτίζει το δείγμα. Μην κοιτάζετε μέσα στον φακό συμπυκνωτή, το δείγμα ή περιφερειακά του δείγματος και επίσης μην κοιτάζετε μέσα στον φακό πεδίου.
- Μην κοιτάζετε απευθείας το έντονο φως από το τμήμα των διόπτρων του σωλήνα προσοφθάλμιου φακού ή τη διδακτική κεφαλή.
- Μην αφαιρείτε τους προσοφθάλμιους φακούς από το τμήμα των διόπτρων όταν ο φωτισμός είναι ενεργοποιημένος.
- Μην κοιτάζετε απευθείας το έντονο φως από τη θύρα της κάμερας απευθείας από επάνω.
- Όταν δεν τοποθετείτε την κάμερα, τοποθετείτε το παρεχόμενο κάλυμμα στη θύρα της κάμερας.



## ΠΡΟΕΙΔΟΠΟΙΗΣΗ

### 8. Μην κοιτάζετε απευθείας στο τμήμα φωτισμού.

Η ακόλουθη ετικέτα προειδοποίησης που υποδεικνύει τον υψηλότερο κίνδυνο (Ομάδα κινδύνου 3) στη φωτοβιολογική ασφάλεια είναι κολλημένη στην πλευρά λαβής της πλάκας, για να υπενθυμίζει στον χρήστη τις ακόλουθες προφυλάξεις. (Για τις τοποθεσίες αυτής της ετικέτας, ανατρέξτε στο σχήμα στο "Chapter 1 Nomenclature of Each Part.")



#### **ΠΡΟΕΙΔΟΠΟΙΗΣΗ (Ομάδα κινδύνου 3)**

Υπέρυθρη ακτινοβολία και πιθανώς επικίνδυνο φως εκπέμπεται από τη θύρα της κάμερας όταν χρησιμοποιείται ο τριοφθάλμιος σωλήνας προσοφθάλμιου φακού.  
Ποτέ μην κοιτάζετε στη θύρα της κάμερας.

#### **ΠΡΟΣΟΧΗ (Ομάδα κινδύνου 2)**

Πιθανώς επικίνδυνο φως εκπέμπεται από τον φακό του συμπυκνωτή όταν χρησιμοποιείται διασκοπικός φωτισμός.  
Μην κοιτάζετε απευθείας το εκπεμπόμενο φως. Ενδέχεται προκληθεί βλάβη στα μάτια.

#### **ΣΗΜΕΙΩΣΗ (Ομάδα κινδύνου 1)**

Πιθανώς επικίνδυνο φως εκπέμπεται από τους προσοφθάλμιους φακούς όταν χρησιμοποιείται διασκοπικός φωτισμός.  
Αποφεύγετε την πολύωρη μικροσκοπική παρατήρηση με έντονο φωτισμό.



## ΠΡΟΣΟΧΗ

### 1. Συναρμολόγηση του μικροσκοπίου

- Συναρμολογήστε το μικροσκόπιο ενώ το τροφοδοτικό AC δεν είναι συνδεδεμένο σε αυτό.
- Φροντίστε να αποφύγετε το μάγκωμα των δακτύλων και των χεριών σας.

### 2. Μην βρέχετε το προϊόν και μην επιτρέψετε την εισχώρηση ξένων σωμάτων.

Μην αφήνετε το προϊόν να βραχεί, καθώς ενδέχεται να προκληθεί δυσλειτουργία, υπερθέρμανση ή ηλεκτροπληξία.

Εάν χυθούν κατά λάθος νερό ή άλλα υγρά επάνω στο προϊόν, αποσυνδέστε αμέσως το καλώδιο τροφοδοσίας από το τροφοδοτικό AC. Έπειτα, σκουπίστε το υγρό με ένα στεγνό πανί.

Η εισχώρηση ξένων σωμάτων στο προϊόν ενδέχεται επίσης να οδηγήσει σε δυσλειτουργία. Εάν υγρά ή ξένα σώματα εισέλθουν στο προϊόν, διακόψτε τη χρήση του προϊόντος και επικοινωνήστε με τον πλησιέστερο αντιπρόσωπο της Nikon.

### 3. Μετακίνηση του προϊόντος

- Το μικροσκόπιο διαθέτει χειρολαβές και λαβές μεταφοράς.  
Υπάρχουν δύο χειρολαβές και στις δύο πλευρές της βάσης και δύο λαβές στον βραχίονα στην πίσω πλευρά του μικροσκοπίου.  
Κατά τη μεταφορά του μικροσκοπίου, κρατήστε το μικροσκόπιο σταθερά από αυτές τις χειρολαβές και λαβές.
- Το τμήμα αποθήκευσης στο πίσω μέρος του μικροσκοπίου δεν είναι λαβή. Μην κρατάτε αυτό το εξάρτημα, καθώς αποθηκεύει το τροφοδοτικό AC και το καλώδιο τροφοδοσίας.
- Κατά τη μετακίνηση του προϊόντος, μην το κρατάτε από τις προεξοχές εστίασης, τον σωλήνα προσοφθάλμιου φακού και την πλάκα κ.λπ. Τα τμήματα ενδέχεται να αποσπαστούν και ενδέχεται επίσης να προκληθούν δυσλειτουργίες.

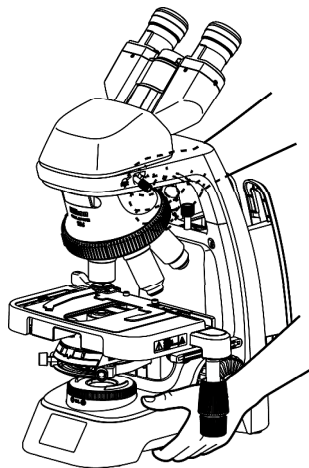
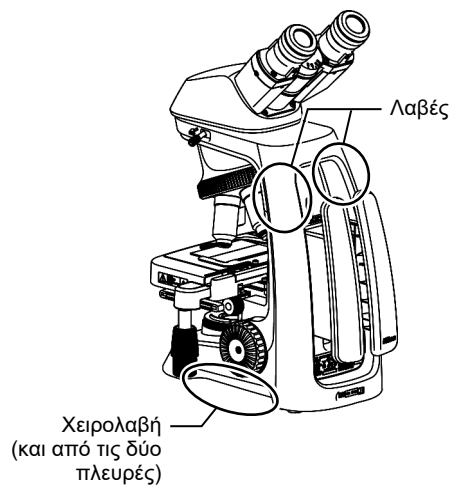

Κρατήστε μια λαβή και μια χειρολαβή.

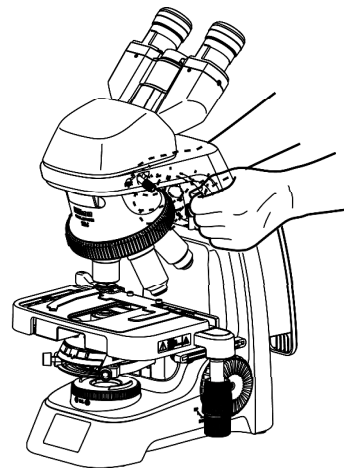

Κρατήστε τις λαβές.

### 4. Απόρριψη του μικροσκοπίου

Για να αποφύγετε τους βιολογικούς κινδύνους, απορρίψτε το μικροσκόπιο ως μολυσμένο εξοπλισμό, σύμφωνα με τις τυπικές διαδικασίες για την εγκατάστασή σας.

## Notes on Handling the Product

### 1. Handle with care.

The product is a precision optical instrument. Handle the product with care and avoid physical shocks and vibrations.

In particular, the precision of objectives may be lost by even weak physical shocks.

### 2. Electromagnetic environment

Before using this product, Nikon recommends evaluating the electromagnetic environment of the installation site.

Do not use this product close to strong electromagnetic radiation sources (example: unshielded intentional RF sources.) They may interfere with the proper operation of this product.

This product emits low-level electromagnetic radiation. Do not install this product near precision electronic devices. Otherwise, the performance of such devices might be degraded. If TV or radio reception is affected, move the TV or radio farther away from this product.

This product complies with requirements of EMC directive (2014/30/EU) and IVD directive (98/79/EC).

- Achieve electromagnetic compatibility to ensure satisfactory operation of the product.  
This product is tested and in conformity with FCC regulations (FCC Part15 Subpart B: Radio Frequency Device (commercial and industrial areas)).
- Use this product only in the commercial or industrial area. Using this product in the residential area may affect other devices.

### 3. Installation location and storage location

The product is a precision optical instrument. Use or storage of the product under inappropriate conditions may result in malfunctions or loss of precision. Details on the installation and storage environment are given in Chapter 7, "Specifications." Additionally, the following conditions must be considered for the installation location and the storage location.

- Avoid placing the product in a hot or humid location. Use or storage of the product in a hot or humid location may result in molding of or condensation on the lenses, loss of precision, and malfunctions.
- Install the product in a place with little dust and dirt.  
When storing the product, place a cover over the product to protect it from dust.
- Install the product in a place with little vibration.
- Install and store the product on a level and sturdy table or stage that can bear the weight of the product.  
Install the product in a location with minimal exposure to hazards in the event of earthquakes and other potential disasters. If necessary, secure the product to the working desk or other heavy and stable items with a strong wire or other means, so as to prevent it from falling.
- Install the product so that the power cord can be unplugged immediately from the AC adapter in case of an emergency.
- Avoid placing the product in direct sunlight or immediately under room lights.  
The image quality is degraded in a bright environment due to the extraneous light entering the objective. A room light immediately above the microscope may also enter the objective as extraneous light. In this case, it is recommended that you turn off the room light above the microscope.
- Install the product at least 10 cm away from the surrounding walls.
- Do not place items on the product.

### 4. Handling optical parts

Handle optical components such as lenses and filters with care, so as not to damage them. Scratches and dirt (i.e., fingerprints) on the optical components will degrade the microscope image. If components require cleaning, clean them by following the procedure in "Chapter 6 Care and Maintenance."

## 5. Fastening plate

The microscope is held tightly by the red fastening plate during shipment. Be sure to remove the plate before use. The microscope cannot be used without removing the fastening plate. For details, see “Chapter 4 Assembly.”

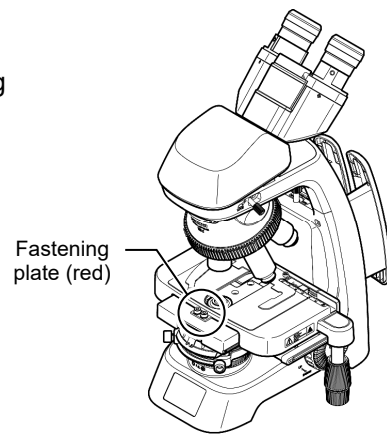

---

This page is intentionally blank.

---

# 1

## Nomenclature of Each Part

This chapter describes the names of parts and the functions of controls of the microscope system.

### Nomenclature of Each Part

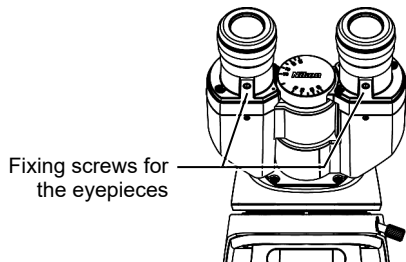
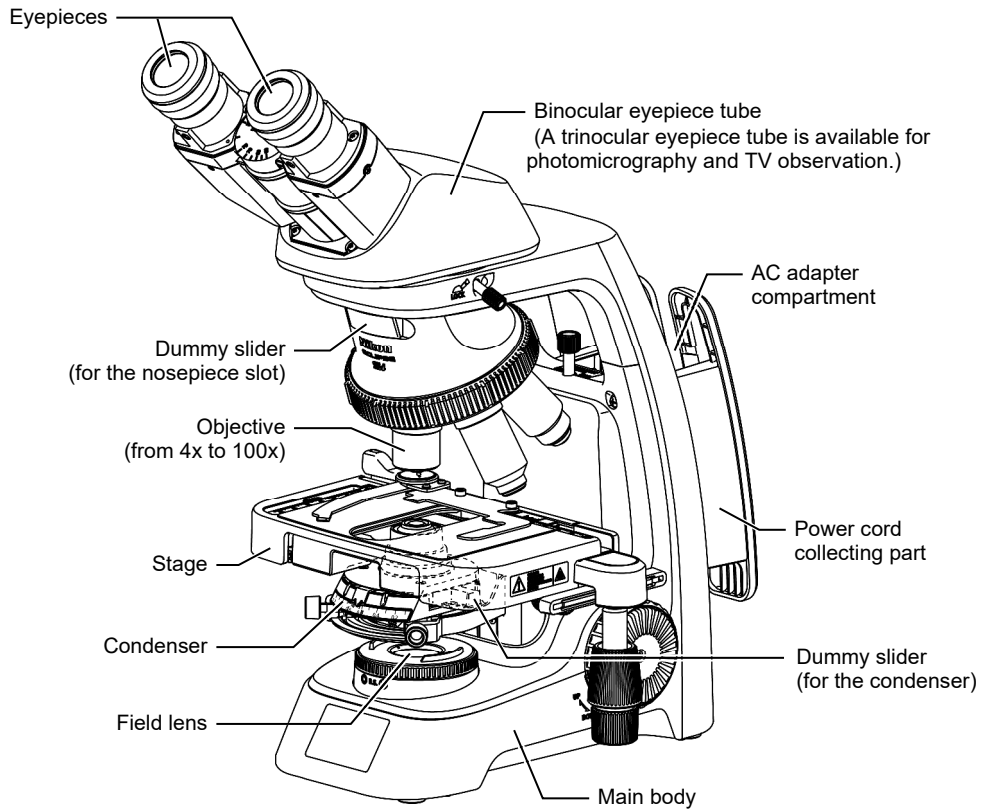

Lower side of the binoculars

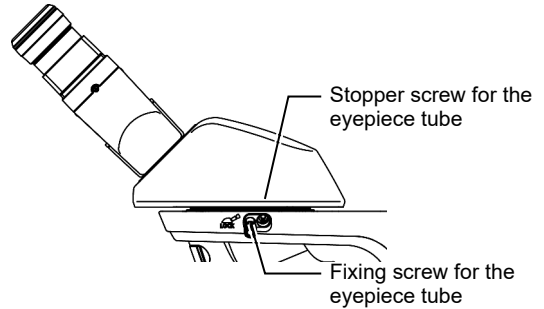

Eyepiece tube mount

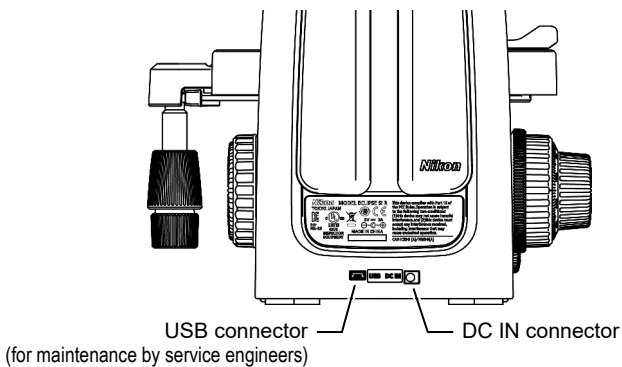

Rear of the microscope

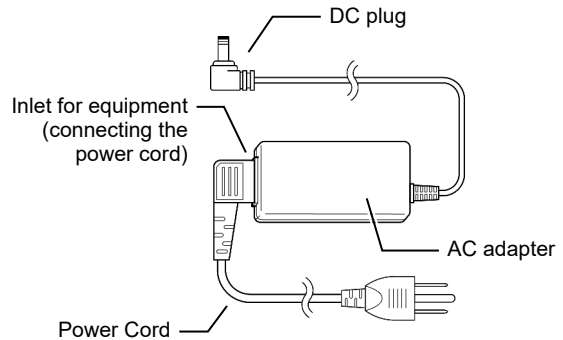

AC adapter and power cord



## Functions of Controls

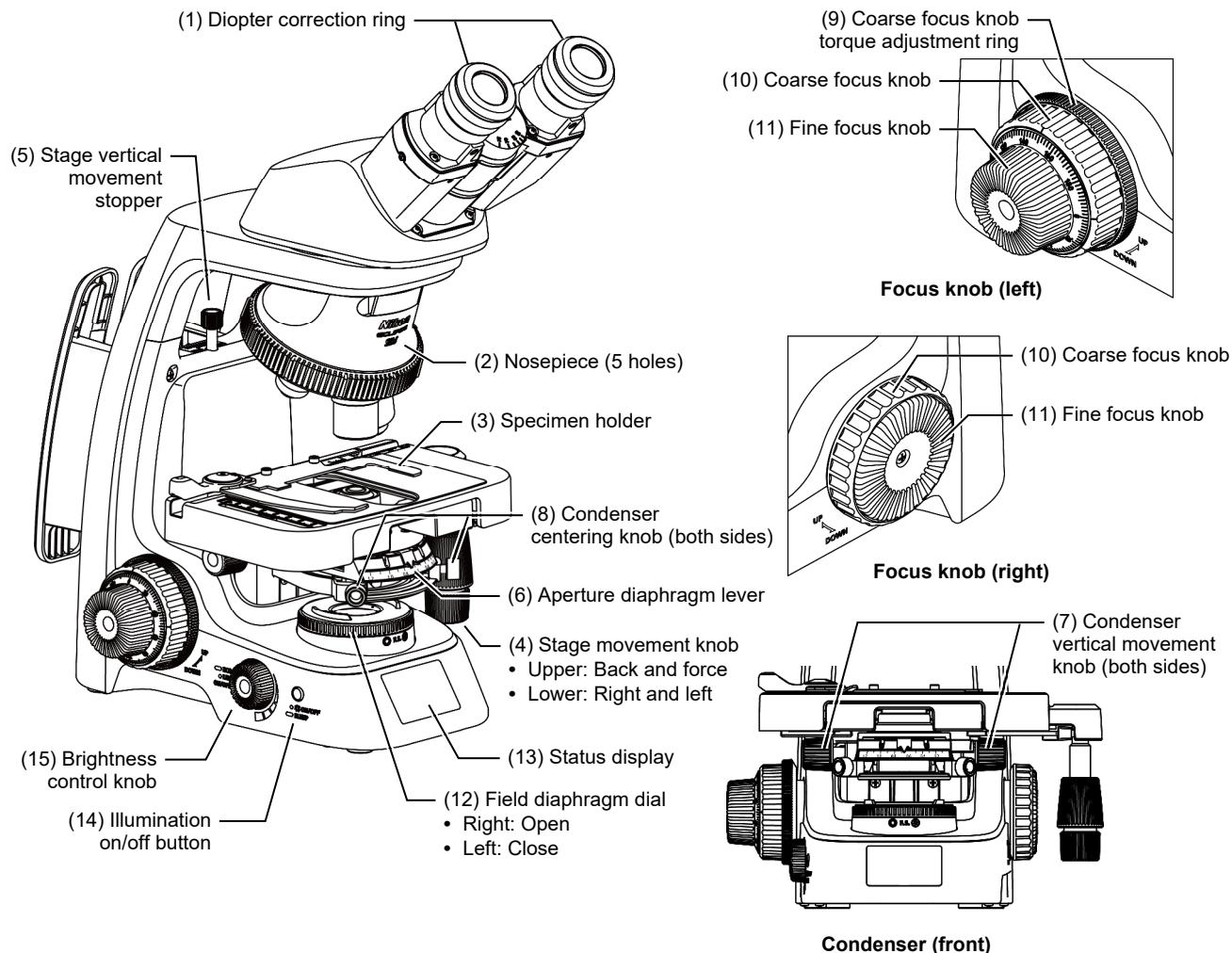

- (1) Diopter ring**  
Compensates for the difference between the right and left eyesight of the observer.
- (2) Nosepiece**  
Switches the objectives.
- (3) Specimen holder**  
Holds a specimen (glass slide).
- (4) Stage movement knob**  
Moves the specimen holder back and forth (upper knob) and right and left (lower knob).
- (5) Stage vertical movement stopper**  
Sets the upper limit of the stage movement. Used for the fail-safe device for specimen and objective damage protection.
- (6) Aperture diaphragm lever**  
Adjusts the aperture diaphragm from  $\phi 1.5$  mm to  $\phi 18$  mm.
- (7) Condenser vertical movement knob**  
Vertically moves the condenser (focusing).
- (8) Condenser centering knob**  
Horizontally moves the condenser (centering).
- (9) Coarse focus knob torque adjustment ring**  
Adjusts the tension of the coarse focus knob.
- (10) Coarse focus knob**  
Used for coarse stage movement (coarse focusing).
- (11) Fine focus knob**  
Used for fine stage movement (fine focusing).
- (12) Field diaphragm lever**  
Adjusts the field diaphragm from  $\phi 1.5$  mm to  $\phi 28$  mm.
- (13) Status display**  
Displays the nosepiece address, objective name, ECO mode state, LIM on/off state, illumination on/off state and brightness control status bar.
- (14) Illumination on/off button**  
Short-press: Turns illumination on or off.  
Long-press: Activates the SLEEP mode.
- (15) Brightness control knob**  
**Controls diascope illumination.**  
**Turn:** Adjust the illumination intensity. (clockwise: brighter, counterclockwise: darker)  
**Light-press:** Turn on/off the light intensity management function (LIM).  
**Long-press:** Turn on/off ECO mode.

# 2

## Microscopy Techniques

This chapter explains the procedures for the five types of microscopy techniques supported by this microscope.

- (1) **Bright-field microscopy (See 2.1.)**
- (2) **Phase contrast microscopy (See 2.2.)**
- (3) **Simple polarizing microscopy (See 2.3.)**
- (4) **Diascopic fluorescence microscopy (See 2.4.)**
- (5) **Dark-field microscopy (See 2.5.)**

- ✓ **Turning on and off the power to the microscope**  
For detail on how to turn on and off the power to the microscope, see “3.1 Turning the Power On and Off.”

- ⓘ **Note on limits on objectives used in each microscopy technique**  
There are limits on the objectives that can be used in each microscopy technique.  
For details on the objectives and microscopy techniques, see “3.11 Combinations of Optical Parts.”

## 2.1 Bright-field Microscopy

Bright-field microscopy is the most basic observation method using diascopic illumination.

For details on the configuration and the assembly of the microscope for bright-field microscopy, see “4.2.1 Basic Configuration (For Bright-field Microscopy).”

### 1 Install the microscope.

- (1) Carry the microscope from the storage location and place it at your location.
- (2) Fix the direction of the eyepiece tube to the observation point (the binoculars are toward you).

Loosen the fixing screw for the eyepiece tube a couple of turns, and then turn the eyepiece tube.

Turn the eyepiece tube so that it faces the front, and securely tighten the fixing screw for the eyepiece tube.

- (3) Pull out the AC adapter and power cord from the storage part on the rear of the product.

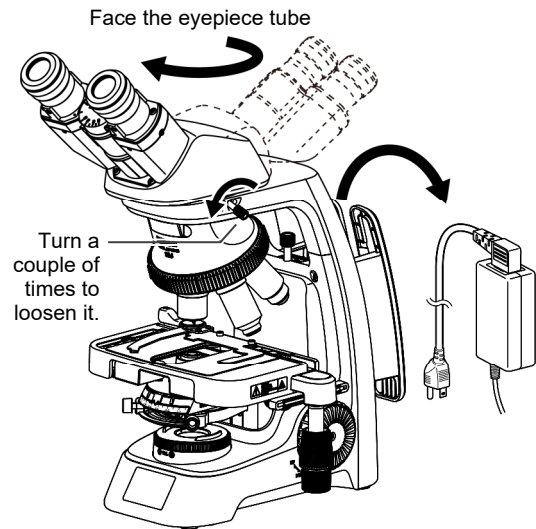

Install the microscope.

### 2 Turn on the microscope.

Connect the AC adapter to power on the microscope.

- (1) Confirm that the DC plug of the AC adapter is connected to the DC input connector on the rear of the main body.
- (2) Plug the power cord of the AC adapter into an electrical outlet

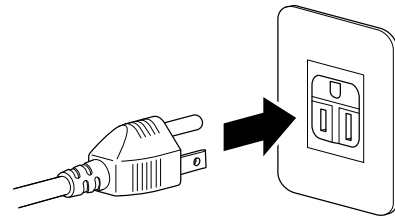

Turn on the microscope.

### 3 Lower the condenser from the upper limit.

When placing the specimen, lower the condenser position by turning the condenser vertical movement knob to avoid accidental contact with the condenser lens.

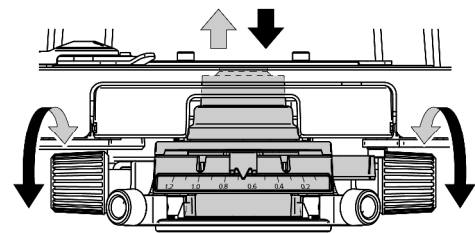

Condenser vertical movement

### 4 Fully open the field diaphragm and the aperture diaphragm.

- (1) Turn the field diaphragm dial clockwise until it reaches the limit.
- (2) Set the aperture diaphragm lever of the condenser at the fully open position (leftmost).

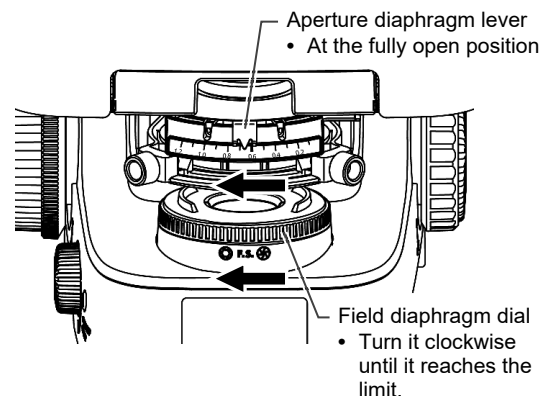

Fully open the field diaphragm and the aperture diaphragm.

**5 Bring the 10x objective into the optical path.**

Rotate the revolving nosepiece to swing the 10x objective into the optical path.

✓ **Turning the nosepiece**

The objective will click into place when rotated into position.

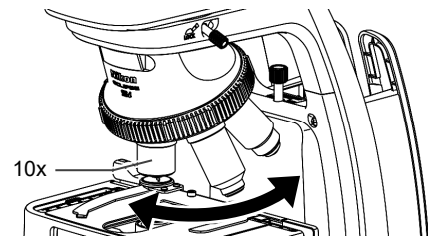

Set the magnification of the objective to 10x.

**6 Place the specimen on the stage, and bring the observation region into the optical path.**

- (1) Use the knob of the claw on the specimen holder to open the claw.
- (2) Place the specimen slide on the stage with the coverglass facing upward, and put the claw back to fix it.
- (3) Turn the stage knobs to bring the observation region of the specimen into the optical path.

Let illumination light go through the specimen sealed under the cover glass.

✓ **Using the specimen holder**

Two glass slides can be placed in two rows on the specimen holder.

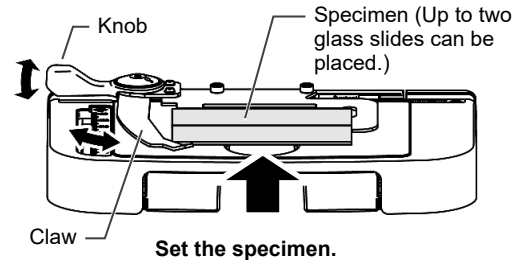

Set the specimen.

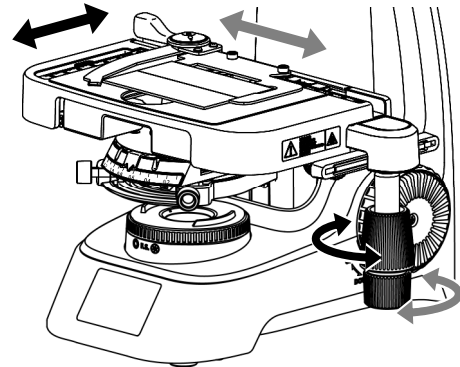

Bring the observation region into the optical path.

**7 Turn on illumination and adjust the brightness.**

The illumination on/off state and the brightness value are shown on the status display.

- (1) Press the illumination on/off button to turn on illumination.

When illumination is turned on, the “on” symbol is shown on the status display.

- (2) Adjust the brightness by rotating the brightness control knob.

The brightness is shown in a bar graph on the status display.

✓ **When light intensity management is on**

When the light intensity management function is turned on (LIM), the brightness of the selected objective is memorized. The memorized brightness is automatically loaded the next time the objective is selected.

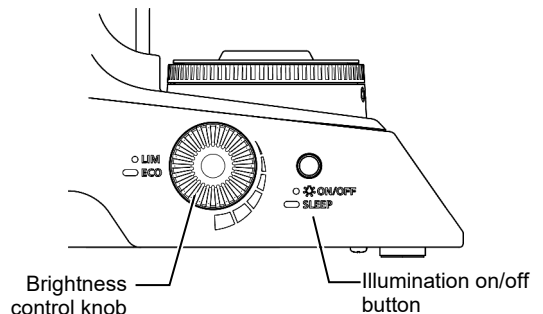

Brightness control knob

Illumination on/off button



“On” symbol

Brightness bar graph

Turn on illumination and adjust the brightness.

**8 Adjust the interpupillary distance.**

Adjust the distance between the eyepieces so that the right and left fields of view are merged into one when looking through the eyepieces.

✓ **Eye level**

When the binocular part is turned upward, the eye level is raised, and when it is turned downward, the eye level is lowered.

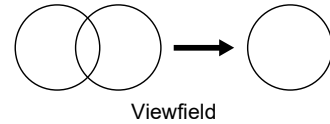
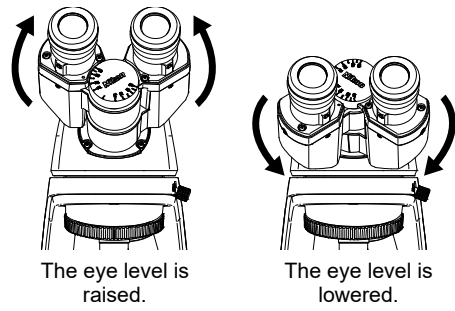

**Adjust the interpupillary distance.**

**9 Align the diopter ring with the standard position.**

Turn the diopter ring on the eyepieces to align its bottom edge with the engraved base line.

Perform this procedure to the right and left eyepieces.

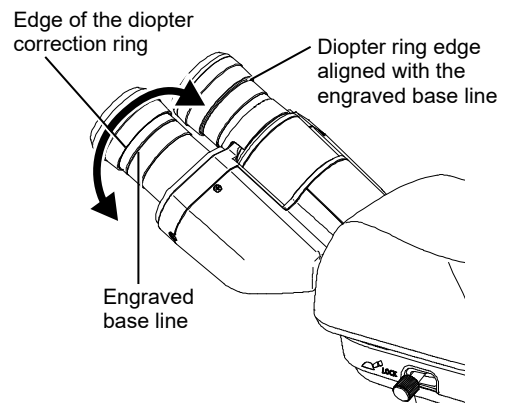

**Set the diopter ring to the standard position.**

**10 Focus on the specimen with the 10x objective.**

Rotate the coarse and then fine focus knobs to focus on the specimen.

❗ **Do not turn the right and left focus knobs simultaneously in opposite directions. Additionally, do not turn the coarse focus knob further after the stage has reached its upper or lower limit. This operation will damage the focusing mechanism.**

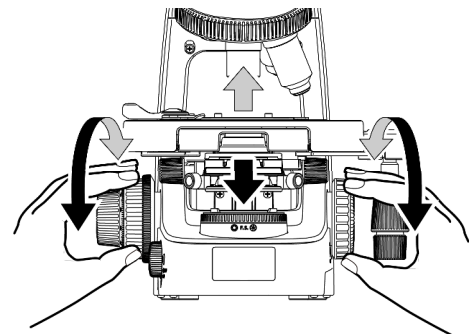
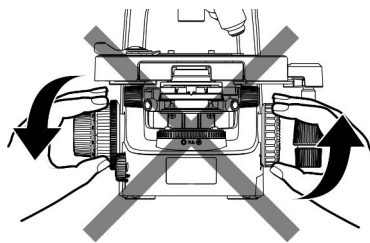

**Focus on the specimen.**

✓ **When the focal point cannot be found**

To find the focal point, rotate the stage vertical movement stopper counterclockwise to unlock the limit.

**11 Adjust the diopter.**

- (1) Swing the 40x objective in the optical path and rotate the focus knobs to focus on the specimen.
- (2) Change the objective to the 10x (or 4x) objective and focus on the specimen by rotating the diopter ring without using the focus knob.

Perform this procedure while looking into the right eyepiece with your right eye and the left eyepiece with your left eye.

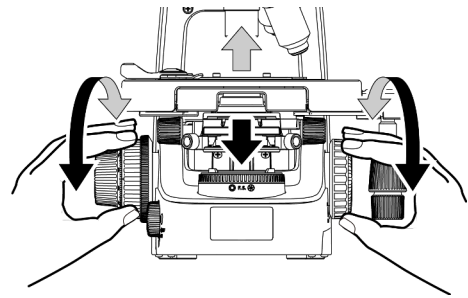

(1) Focusing with the 40x objective by rotating the focus knobs

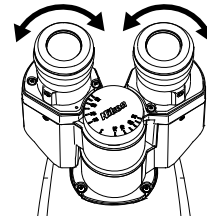

(2) Focusing with the 10x objective by rotating the diopter rings

**Adjust the diopter.**

**12 Perform focusing and centering of the condenser.**

Adjust the condenser so that illumination is correctly introduced to the specimen.

- (1) Turn the field diaphragm dial to narrow down the field diaphragm until the field diaphragm image can be seen in the field of view.
- (2) Turn the condenser vertical movement knob to focus on the field diaphragm image.

Focus on the field diaphragm image so that its outline is clearly seen.

- (3) Turn the condenser centering knob to perform centering of the condenser.

Move the condenser so that the field diaphragm image is in the center of the field of view.

- (4) Turn the field diaphragm dial to resize the field diaphragm image so that it is circumscribed with the field of view.

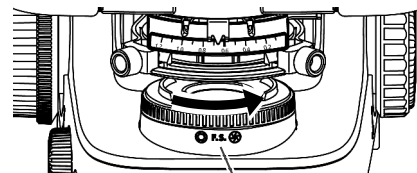

Narrow down the field diaphragm until the field diaphragm image can be seen.

(1) Narrow down the field diaphragm until the field diaphragm image can be seen.

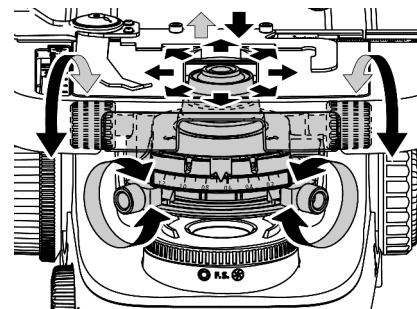

(2) Focus on the field diaphragm image.  
(3) Move the field diaphragm image to the center of the field of view.

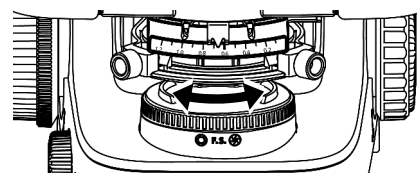

(4) Resize the field diaphragm image so that it is circumscribed with the field of view.

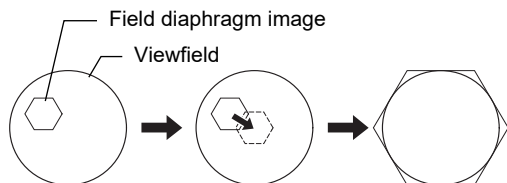

Focus on the field diaphragm image, move it to the center of the field of view, and resize the image so that it fits the field of view.

**Perform focusing and centering of the condenser.**

**13 Change the objective to the objective of the magnification used for observation.**

Rotate the revolving nosepiece to bring the objective of the desired magnification into the optical path.

**!** Do not directly switch from the 4x objective to the 60x or 100x objective. Be sure to focus on the specimen with the 10x objective before using the objective of a higher magnification.

- ✓ **When using an oil-immersion objective**  
Apply immersion oil between the specimen and the objective.
- ✓ **When light intensity management is on**  
When the light intensity management function is turned on (LIM), bringing the objective into the optical path loads the memorized brightness.

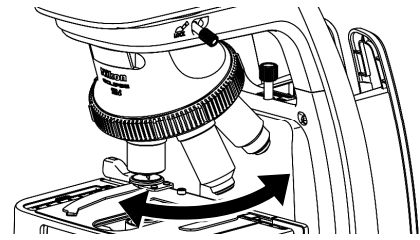

Switch to the objective to be used for observation.

**14 Adjust the aperture diaphragm according to the objective.**

Check the NA value of the objective, and set the aperture diaphragm lever to the position of the same figure as the NA of the objective.

→ Section 3.8, “Adjustment of Aperture Diaphragm”

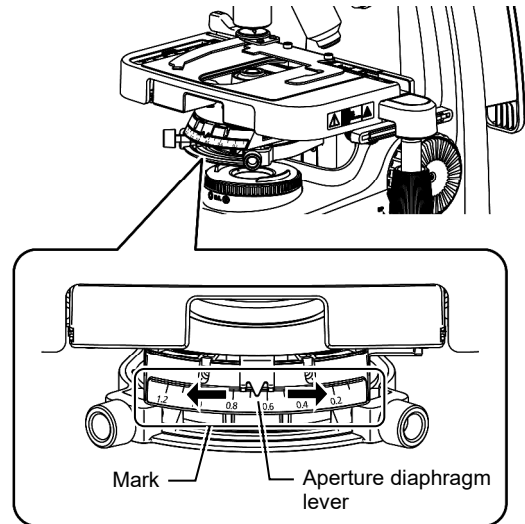

Adjust the aperture diaphragm.

**15 Focus on the specimen.**

Rotate the coarse and then fine focus knobs to focus on the specimen.

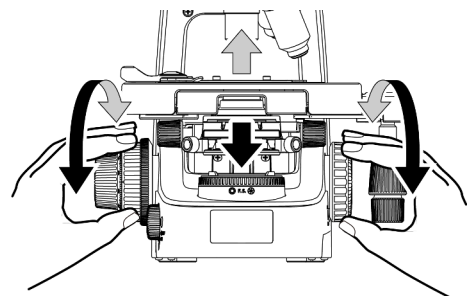

Focus on the specimen.

**16 Perform focusing and centering of the condenser.**

- (1) Turn the field diaphragm dial to narrow down the field diaphragm until the field diaphragm image can be seen in the field of view.
- (2) Turn the condenser vertical movement knob to focus on the field diaphragm image.  
Focus on the field diaphragm image so that its outline is clearly seen.
- (3) Turn the condenser centering knob to perform centering of the condenser.  
Move the condenser so that the field diaphragm image is in the center of the field of view.
- (4) Turn the field diaphragm dial to resize the field diaphragm image so that it is circumscribed with the field of view.

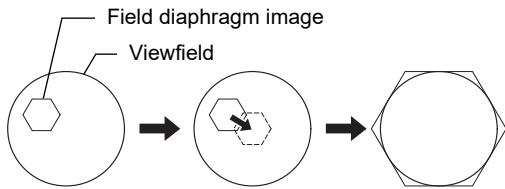

Focus on the field diaphragm image, move it to the center of the field of view, and resize the image so that it fits the field of view.

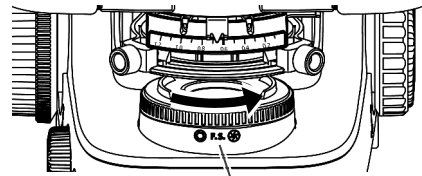

Narrow down the field diaphragm until the field diaphragm image can be seen.

- (1) Narrow down the field diaphragm until the field diaphragm image can be seen.

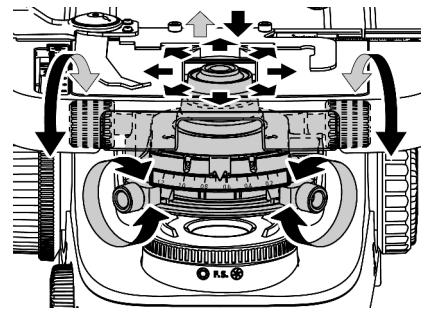

- (2) Focus on the field diaphragm image.
- (3) Move the field diaphragm image to the center of the field of view.

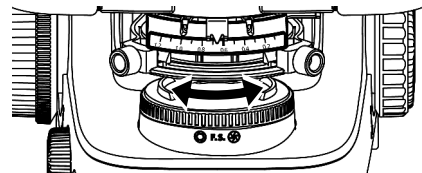

- (4) Resize the field diaphragm image so that it is circumscribed with the field of view.

**Perform focusing and centering of the condenser.**

**17 Observe the specimen.**

Turn the stage and focus knobs to observe the specimen.

To observe the specimen with a different magnification, repeat steps 13 to 17.

**18 Turn off the microscope.**

- (1) Press the illumination on/off button to turn off illumination.  
The "on" symbol disappears from the status display.
- (2) Unplug the power cord from the electrical outlet

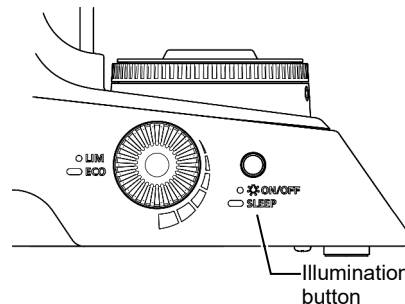

**Turn off illumination.**



**19 Store the microscope.**

After observation, turn the eyepiece tube backward and fix it.

**!** Loosen the fixing screw for the eyepiece tube a couple of turns, and then turn the eyepiece tube.

Store the AC adapter in the storage part on the rear of the microscope, wind the cords around, and then put it back in place.

**✓ AC adapter**

The AC adapter can be stored with it connected to the microscope.

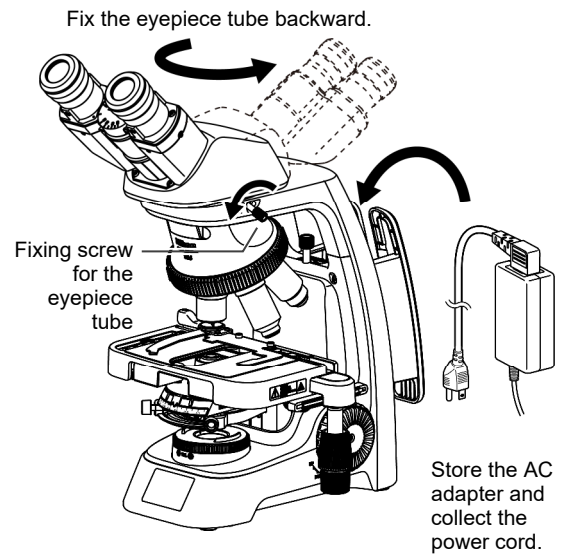

**Fix the eyepiece tube backward and store the AC adapter.**

## 2.2 Phase Contrast Microscopy

Phase contrast microscopy is a method of using diasopic illumination to observe unstained, colorless and transparent specimens such as live cells.

Phase contrast microscopy uses the interference between direct light and light diffracted while passing through a colorless and transparent specimen to visualize light phase shifts as brightness variations.

Insert the phase contrast slider with the annular diaphragm into the slot on the side of the condenser, and bring the phase contrast objective with the same PH code into the optical path. The microscope is now ready for phase contrast microscopy.

For details on the configuration and the assembly of the microscope for phase contrast microscopy, see “4.2.2 Configuration for Phase Contrast Microscopy.”

### 1 Prepare the microscope.

Check that the following optical parts are usable.

#### (1) Phase contrast slider

**Slider for 10x-40x:** Supports 10x and 40x Ph objectives. When switching to phase contrast microscopy, remove the dummy slider from the slot on the side of the condenser and insert this slider.

**Slider for 100x:** Supports 100x Ph objectives. An empty position is available, so bring the empty position into the optical path in advance. When switching to phase contrast microscopy, operate the slider to bring the phase contrast position into the optical path.

#### (2) Phase contrast objective (Ph objective)

Check that the Ph objective is attached to the nosepiece.

#### ✓ Combination of optical parts

Confirm in advance that the slider is paired with a supported objective with a supported PH code.

#### (3) GIF filter (green interference filter)

Attach the GIF filter to the field lens when performing phase contrast microscopy.

#### (4) Centering telescope

Use the centering telescope when adjusting the annular diaphragm position.

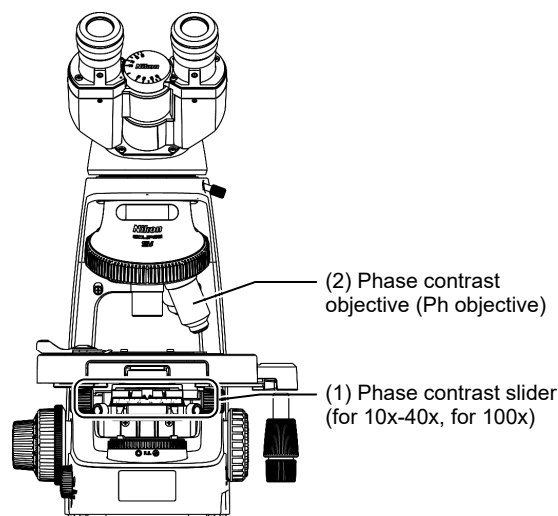

(3) GIF filter

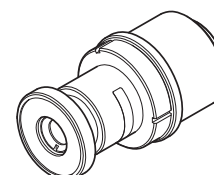

(4) Centering telescope

### 2 Focus on the target in bright field microscopy.

Follow steps 1 to 12 of the procedure in “2.1 Bright-field Microscopy”, and focus on the target using the 10x objective with the bright-field microscopy method.

### 3 Bring the phase contrast objective into the optical path.

Turn the nosepiece to bring the phase contrast objective (Ph objective) of the desired magnification into the optical path.

The phase contrast ring inside the objective is brought into the optical path.

Check the objective magnification and the PH code.

**!** Do not directly switch from the 4x objective to the 100x objective. Be sure to focus on the specimen with the 10x objective before using the objective of a higher magnification.

- ✓ **When using an oil-immersion objective**  
Apply immersion oil between the specimen and the objective.
- ✓ **When light intensity management is on**  
When the light intensity management function is turned on (LIM), bringing the objective into the optical path loads the memorized brightness.

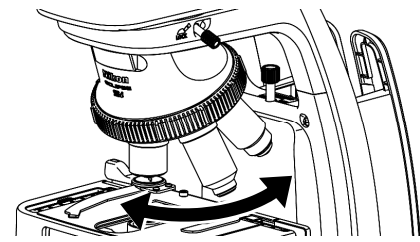

Switch to the phase contrast objective.

### 4 Focus on the specimen.

Rotate the coarse and then fine focus knobs to focus on the specimen.

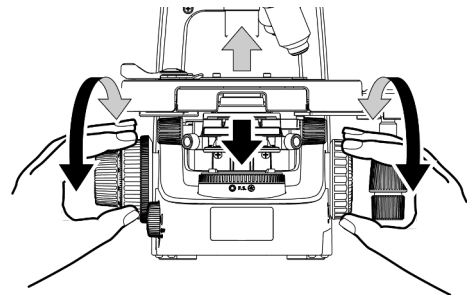

Focus on the specimen.

### 5 Insert the phase contrast slider and bring the phase contrast position (PH) into the optical path.

#### (1) Set the aperture diaphragm lever at the fully open position.

When inserting or removing sliders, always make sure the aperture diaphragm lever is at the fully open position.

#### (2) Pull the dummy slider out of the slot on the side of the condenser.

The 100x phase contrast slider has an empty position. Bright-field microscopy can be performed by attaching the slider and bringing the empty position into the optical path in advance.

#### (3) Insert the phase contrast slider so that the centering screw of the annular diaphragm faces the front of the microscope, and the operating knob is on the left side.

Remove the slider knob, insert the slider facing the appropriate direction, and re-attach the knob to the slider.

Bring the position of the same PH code as the objective into the optical path. The annular diaphragm is brought into the optical path.

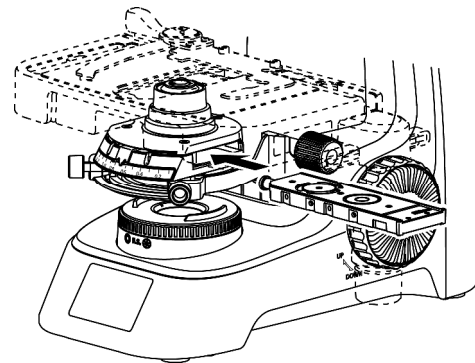

#### Inserting the phase contrast slider

- (1) **Remove the knob from the slider.**  
The knob is in the form of a screw. Unscrew the knob to remove it.
- (2) **Insert the slider into the slot on the side of the condenser.**  
The slider has protrusions to prevent incorrect insertion.
- (3) **Attach the knob to the slider you attached.**  
Attach the slider knob from the left side of the condenser.

Insert the phase contrast slider.

**6 Overwrap the annular diaphragm image with the annular image of the phase plate using the centering telescope.**

- (1) Remove one eyepiece, attach the centering telescope, and focus on the annular diaphragm image.

Focus on the specimen by turning the eyepiece while pressing down on the flange ring of the centering telescope.

- (2) Overwrap the annular diaphragm image with the annular image of the phase plate.

Insert the tool from the hole on the front of the condenser, turn the annular diaphragm centering screw of the phase contrast slider, and overlap the annular image of the phase plate of the objective with the annular diaphragm image.

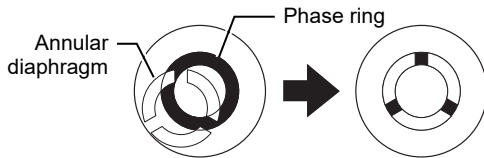

Centering adjustment of the annular diaphragm

- (3) Replace the centering telescope with the eyepiece.

**7 Adjust the aperture diaphragm and field diaphragm.**

- (1) Set the aperture diaphragm lever of the condenser at the fully open position (leftmost).
- (2) Turn the field diaphragm dial to resize the field diaphragm image so that it is circumscribed with the field of view.

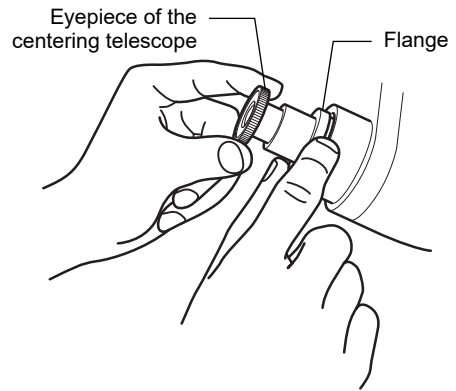

- (1) Focus on the annular diaphragm image using the centering telescope.

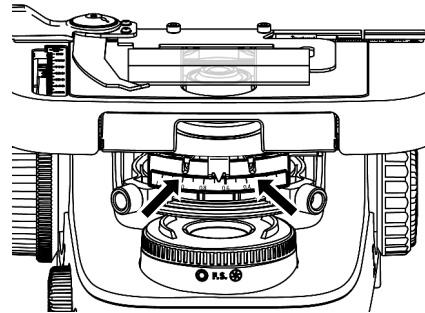

- (2) Adjust the position of the condenser so that the annular image of the phase plate and the annular diaphragm image overlap.

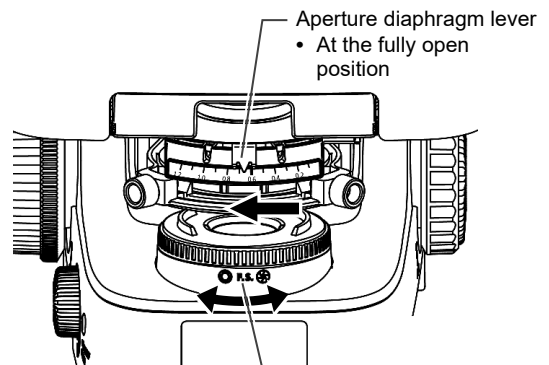

- Field diaphragm dial
  - Adjust it so that the image is circumscribed with the field of view

Adjust the field diaphragm and the aperture diaphragm.

**8 Attach the GIF filter (green interference filter) to the field lens.**

The contrast of the Ph image is improved by using the GIF filter.

**9 Observe the specimen using the phase contrast microscopy method.**

Turn the stage and focus knobs to observe the specimen.

To observe the specimen with a different magnification, repeat steps 3 to 7.

**10 Switch to bright-field microscopy.**

**(1) Remove the phase contrast slider to remove the annular diaphragm from the optical path.**

Remove the slider knob on the left side of the condenser, and pull the slider out from the right side of the condenser.

**(2) Bring the objective for bright-field microscopy into the optical path.**

## 2.3 Simple Polarizing Microscopy

Simple polarizing microscopy is an observation method for measuring polarization, refraction, and other states of the specimen by bringing the analyzer and polarizer into the microscope's optical path to limit the light's vibration direction.

For details on the configuration and the assembly of the microscope for simple polarizing microscopy, see "4.2.3 Configuration for Simple Polarizing Microscopy."

✓ **Supported polarizing microscopy**

Of the polarizing microscopy methods, this microscope only supports simple polarizing microscopy. Polarizing microscopy using sensitive color is not supported.

### 1 Prepare the microscope.

Check that the following optical parts are usable.

#### (1) Simple polarization analyzer

When switching to simple polarizing microscopy, attach it to the dovetail for the eyepiece tube mount.



(1) Simple polarization analyzer

#### (2) Simple polarization polarizer

When switching to simple polarizing microscopy, attach it to the field lens.

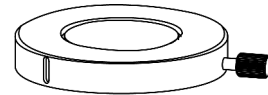

(2) Simple polarization polarizer

### 2 Focus on the target using the bright field microscopy method.

Follow steps 1 to 12 of the procedure in "2.1 Bright-field Microscopy", and focus on the target using the 10x objective with the bright-field microscopy method.

### 3 Bring the position without samples into the optical path.

Turn the stage knob to move the specimen and bring a portion where there is no sample under the cover glass into the optical path.

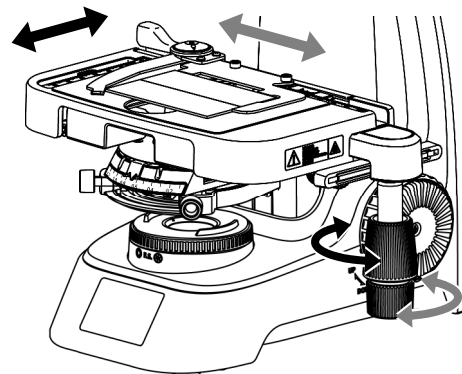

Bring the position without samples into the optical path.

**4 Bring the analyzer and the polarizer into the optical path.**

**(1) Turn off diascopic illumination.**

Press the illumination on/off button to turn off diascopic illumination.

**(2) Attach the simple polarization analyzer.**

Remove the eyepiece tube, attach the simple polarization analyzer to the dovetail for the eyepiece tube mount, and re-attach the eyepiece tube at its original position.

Make sure the mark showing the analyzer orientation faces the same position as the screws on the rear of the microscope. The (vibration) direction of the analyzer is fixed at the microscope front and back direction.

**(3) Attach the simple polarization polarizer.**

Attach the simple polarization polarizer unit over the field lens.

Make sure the mark showing the polarizer orientation faces the front of the microscope, and keep the fixing screw in the polarizer unit loose.

**(4) Turn on diascopic illumination.**

Press the illumination on/off button to turn on diascopic illumination.

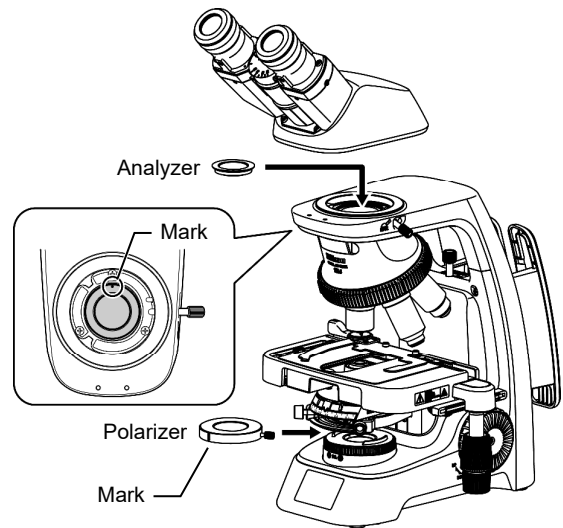

**Bring the analyzer and the polarizer into the optical path.**

**5 Adjust the angle of the polarizer so that the orientations of the analyzer and polarizer are at right angles to each other.**

**(1) Fully open the aperture diaphragm.**

**(2) Pull one eyepiece out of the eyepiece tube, and look inside the eyepiece tube sleeve.**

When you look inside the eyepiece tube sleeve, you can see a black striped pattern showing the polarization state. Turning the entire polarizer unit changes the pattern.

**(3) Turn the entire polarizer unit so that a dark cross is visible inside the eyepiece tube sleeve.**

If you turn the polarizer unit so that its mark faces the front of the microscope, the polarizer is set to a horizontal orientation, and the orientations of the polarizer and analyzer converge at a right angle.

This state is known as "crossed Nicol." If the orientations successfully converge at a right angle, a dark cross is visible inside the eyepiece tube sleeve.

**(4) Tighten the fixing screw in the polarizer unit, and fix the polarizer in place.**

The fixing screw must come in contact with a boundary protrusion of the field lens.

To fix the polarizer in an open Nicol state, remove the fixing screw, move it to another screw hole, and tighten the screw.

**(5) Replace the centering telescope with the eyepiece.**

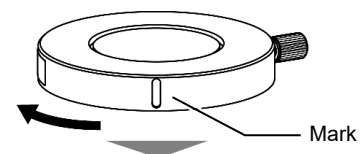

Turn the polarizer so that a dark cross is visible.

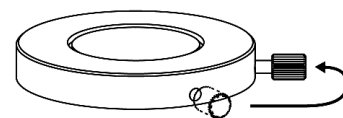

Open Nicol state (mark on the left side)  
(To fix the polarizer in place, move the fixing screw to another position.)

**6 Bring an objective into the optical path.**

Rotate the revolving nosepiece to bring the objective of the desired magnification into the optical path.

**!** Do not directly switch from the 4x objective to the 100x objective. Be sure to focus on the specimen with the 10x objective before using the objective of a higher magnification.

✓ **When using an oil-immersion objective**  
Apply immersion oil between the specimen and the objective.

✓ **When light intensity management is on**  
When the light intensity management function is turned on (LIM), bringing the objective into the optical path loads the memorized brightness.

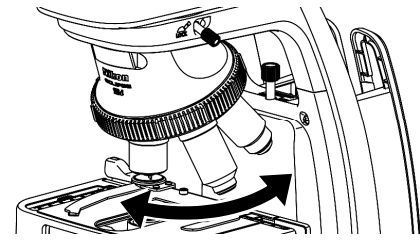

Switch to the desired objective.

**7 Focus on the specimen.**

Rotate the coarse and then fine focus knobs to focus on the specimen.

Adjust the brightness of diascopic illumination and move the observation region by moving the stage as required.

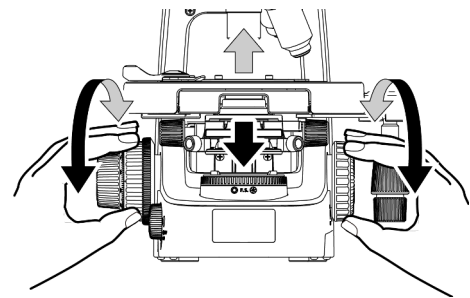

Focus on the specimen.

**8 Adjust the field diaphragm.**

Turn the field diaphragm dial to resize the field diaphragm image so that it is circumscribed with the field of view.

✓ **Adjustment of field diaphragm**  
Each time you change the objective, adjust the field diaphragm.

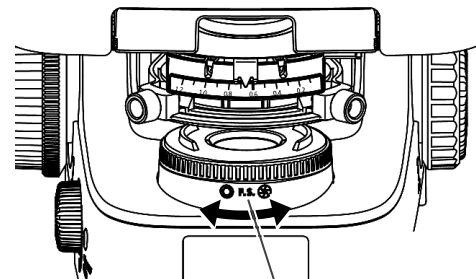

Adjust it so that the image is circumscribed with the field of view

Adjust the field diaphragm.

**9 Observe the specimen using the simple polarizing microscopy method.**

Turn the stage and focus knobs to observe the specimen.

To observe the specimen with a different magnification, repeat steps 6 to 8.



**10 Switch to bright-field microscopy.**

**(1) Turn off diascope illumination.**

Press the illumination on/off button to turn off diascope illumination.

**(2) Remove the simple polarization analyzer.**

Remove the eyepiece tube, remove the simple polarization analyzer from the dovetail for the eyepiece tube mount, and re-attach the eyepiece tube at its original position.

**(3) Remove the simple polarization polarizer.**

Loosen the fixing screw in the polarizer unit, and remove the polarizer unit from the field lens.

**(4) To continue observation, turn on diascope illumination.**

Press the illumination on/off button to turn on diascope illumination.

## 2.4 Diascopic Fluorescence Microscopy

Diascopic fluorescence microscopy is a microscopy method for using diascopic illumination to examine specimens stained with fluorescent dye or fluorescent protein. You can observe excited fluorescence as an image by directing diascopic illumination of a particular wavelength at objects stained with special fluorescent dye.

This microscope can be used for observation by diascopic fluorescence (GFP-B) by using the E2-F-FL Dia-FL Set GFP-B. You can perform observation using GFP, FITC, Alexa 488, and more.

✓ **Note on the brightness of excited fluorescence**

The brightness of fluorescent light excited during diascopic fluorescence microscopy might be reduced, for example due to the expression efficiency of the sample GFP.

Nikon recommends darkening the room because images are not clearly visible if the ambient light is too bright.

For details on the configuration and the assembly of the microscope for diascopic fluorescence microscopy, see “4.2.4 Configuration for Diascopic Fluorescence Microscopy.”

### 1 Prepare the microscope.

Attach the following optical parts and the shielding plate to the microscope in advance:

#### (1) EX filter slider

When performing bright-field microscopy, bring the BF position into the optical path, and when performing diascopic fluorescence microscopy, bring the GFP position into the optical path.

#### (2) BA filter slider

When performing bright-field microscopy, pull the slider out to the click position and bring the empty position into the optical path. When performing diascopic fluorescence microscopy, push the slider in all the way and bring the BA filter into the optical path.

#### (3) Diascopic fluorescence objective

When performing diascopic fluorescence microscopy, you can use three types of objectives: CFI E Plan 4x, CFI E Plan 10x, and CFI E Plan 40x.

#### (4) Shielding plate

Attach the shielding plate to prevent strong light including UV light from the specimen through the condenser from flashing into your eyes.

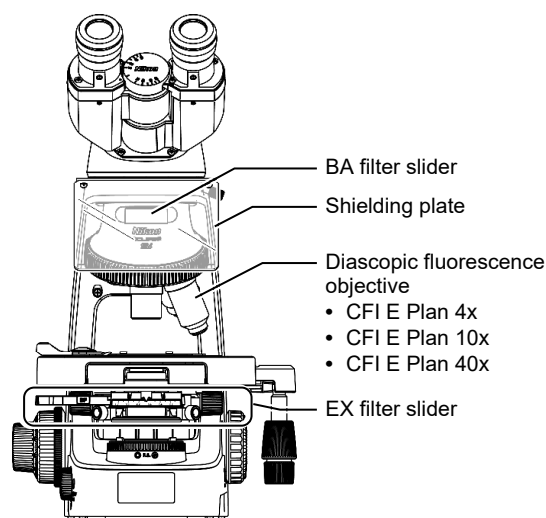

### 2 Focus on the target using the bright field microscopy method.

Follow steps 1 to 12 of the procedure in “2.1 Bright-field Microscopy”, and focus on the target using the 10x objective with the bright-field microscopy method.

**3 Bring the diascope fluorescence objective into the optical path.**

Turn the nosepiece to bring the objective into the optical path.

- ✓ **When light intensity management is on**  
When the light intensity management function is turned on (LIM), bringing the objective into the optical path loads the memorized brightness.

❗ **Note on using light intensity management**  
If diascope fluorescence microscopy was being performed last time the microscope was used, beware that bright light might enter the optical path.

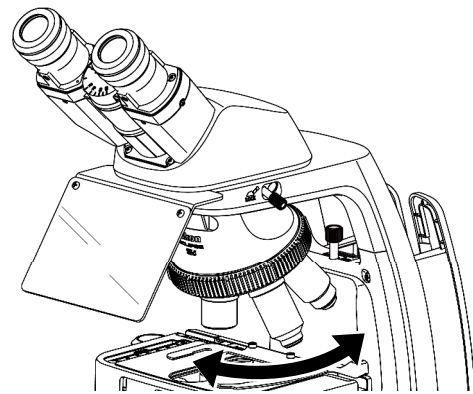

Switch to the diascope fluorescence objective.

**4 Focus on the specimen.**

Rotate the coarse and then fine focus knobs to focus on the specimen.

Adjust the brightness of diascope illumination and move the observation region by moving the stage as required.

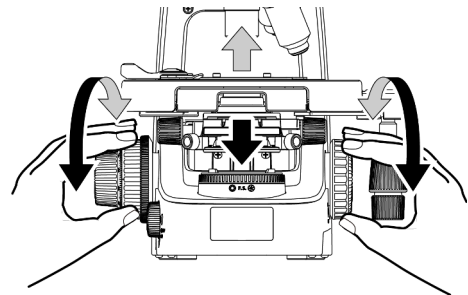

Focus on the specimen.

**5 Adjust the field diaphragm.**

Turn the field diaphragm dial to resize the field diaphragm image so that it is circumscribed with the field of view.

- ✓ **Adjustment of field diaphragm**  
Each time you change the objective, adjust the field diaphragm.

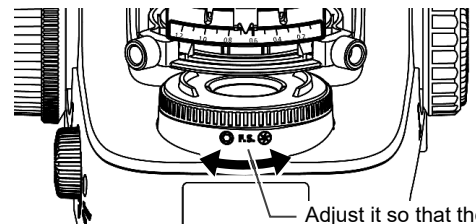

Adjust it so that the image is circumscribed with the field of view

Adjust the field diaphragm.

**6 Bring the excitation filter and barrier filter into the optical path, and adjust the illumination to set the microscope to diascope fluorescence microscopy.**

**(1) From the right side, push the EX filter slider inserted in the slot on the side of the condenser. This sets the slider to the GFP position.**

The excitation filter is brought into the optical path.

**!** **Move your eyes away the eyepieces during position switching.**  
**Fluorescence microscopy is performed with diascope illumination set to maximum.**  
**Therefore, bright light might reach the binoculars when the position of the fluorescence microscopy slider is switched.**  
**Move your eyes away from the binoculars during position switching.**

Push the slider into the click position. The aperture diaphragm lever is automatically set to fully open (NA 1.25), and is no longer operable.

**(2) Push the BA filter slider all the way into the front slot of the nosepiece.**

The barrier filter is brought into the optical path.

**(3) Adjust the brightness of diascope illumination.**

Brighten the diascope illumination so that the specimen is excited and emits fluorescence.

**✓ Illumination during diascope fluorescence microscopy**

To perform fluorescence microscopy, use illumination close to the maximum illumination intensity.

**7 Observe the specimen using the diascope fluorescence microscopy method.**

Turn the stage and focus knobs to observe the specimen.

To observe the specimen with a different magnification, repeat steps 6 to 8.

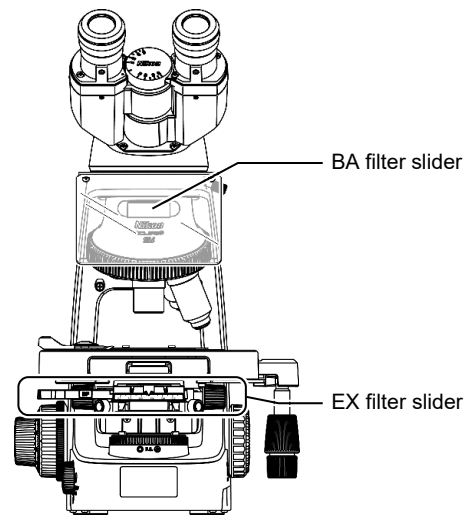

(1) Set the EX filter slider to the GFP position.  
 (2) Push the BA filter slider in all the way.

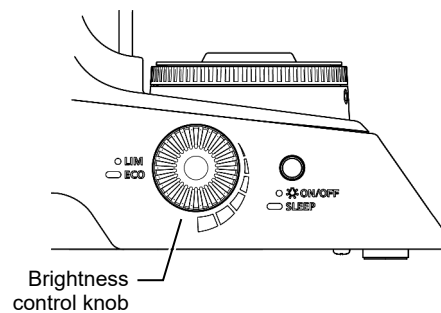

(3) Adjust the brightness of diascope illumination.

**Set the microscope to use diascope fluorescence.**

**8 Switch to bright-field microscopy.**

**(1) Darken diascope illumination, and then turn off diascope illumination.**

Turn the brightness control knob to darken diascope illumination. Then, press the illumination on/off button to turn off diascope illumination.

**(2) Pull the BA filter slider up to the click position.**

The barrier filter is removed from the optical path.

**!** Move your eyes away from the eyepieces during position switching.  
Beware that if you remove the barrier filter from the optical path while looking into the eyepiece during diascope fluorescence microscopy, light might flash into your eye, causing eye damage.  
When setting the microscope back to bright-field microscopy, either turn off diascope illumination or keep your eyes away from the eyepiece.

**(3) Insert the EX filter slider from the left side up to the click position, and set it at the BF position (for bright-field microscopy).**

The empty position is brought into the optical path.

**(4) To continue observation, turn on diascope illumination.**

Press the illumination on/off button to turn on diascope illumination.

## 2.5 Dark-field Microscopy

Dark-field microscopy is a method of using oblique illumination to observe unstained specimens. A bright observation target can be visualized on a dark background in high contrast.

In dark-field microscopy, the annular diaphragm narrows the illumination to an annular shape, and light passes through the edge of the condenser lens to obliquely illuminate the specimen. Using an objective with a smaller numerical aperture than the condenser lens allows only light scattered by the specimen to pass through the objective to form a dark-field image.

For details on the configuration and the assembly of the microscope for dark-field microscopy, see “4.2.5 Configuration for Dark-field Microscopy.”

### 1 Prepare the microscope.

Check that the following optical parts are usable.

#### (1) Slider for dark-field microscopy

When performing bright-field microscopy, bring the empty position into the optical path, and when performing dark-field microscopy, bring the dark-field position into the optical path.

#### (2) Objective for dark-field microscopy

Check that the objective is attached to the nosepiece.

#### ✓ Combination of optical parts

There are limits on the NA values of objectives that can be used with dark-field microscopy.

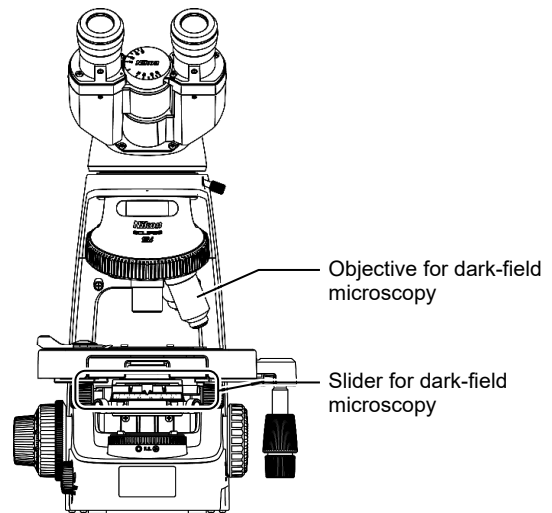

### 2 Focus on the target using the bright field microscopy method.

Follow steps 1 to 12 of the procedure in “2.1 Bright-field Microscopy”, and focus on the target using the 10x objective with the bright-field microscopy method.

### 3 Insert the dark-field slider and bring dark-field position into the optical path.

Insert the dark-field slider from the right side up to the click position, and bring the dark-field position into the optical path.

The dark-field annular diaphragm is brought into the optical path. The microscope is now ready for dark-field microscopy.

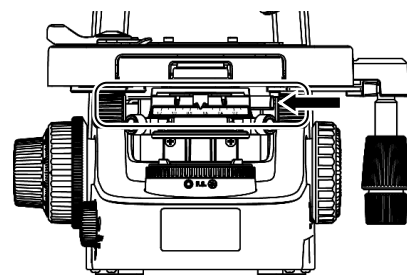

Bring the objective for dark-field microscopy into the optical path.

**4 Fully open the filed diaphragm and the aperture diaphragm.**

- (1) Turn the field diaphragm dial clockwise until it reaches the limit.
- (2) Set the aperture diaphragm lever of the condenser at the fully open position (leftmost).

- ✓ **Condenser position**  
Move the condenser to the position where the image is clear under dark-field illumination.  
The position slightly lower than the upper limit would be suitable.

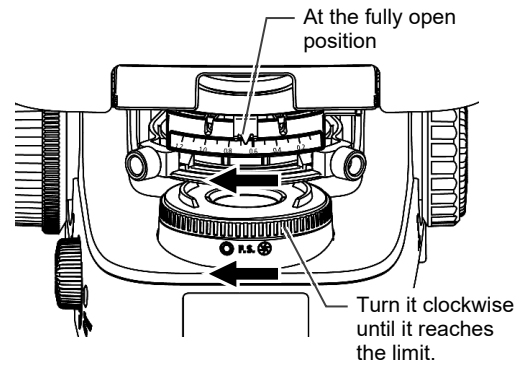

**Fully open the field diaphragm and the aperture diaphragm.**

**5 Bring an objective into the optical path.**

Rotate the revolving nosepiece to bring the objective of the desired magnification into the optical path.

- ❗ **Do not directly switch from the 4x objective to the 100x objective. Be sure to focus on the specimen with the 10x objective before using the objective of a higher magnification.**

- ✓ **When using an oil-immersion objective**  
Apply immersion oil between the specimen and the objective.
- ✓ **When light intensity management is on**  
When the light intensity management function is turned on (LIM), bringing the objective into the optical path loads the memorized brightness.

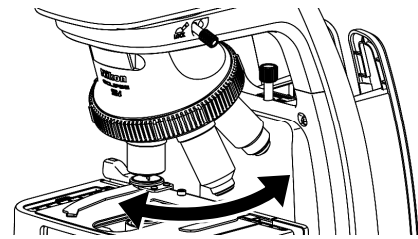

**Switch to the suitable objective.**

**6 Adjust the brightness of diascope illumination.**

Adjust the brightness of diascope illumination by turning the brightness control knob.

In dark-field microscopy, the background darkens, and the target is illuminated from an angle. Adjust the brightness to observe the specimen as desired.

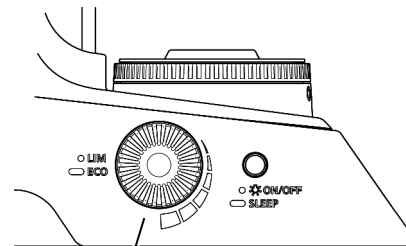

Brightness control knob  
**Adjust the brightness of diascope illumination.**

**7 Focus on the specimen.**

Rotate the coarse and then fine focus knobs to focus on the specimen.

**8 Observe the specimen using the dark-field microscopy method.**

Turn the stage and focus knobs to observe the specimen.

To observe the specimen with a different magnification, repeat steps 5 to 7.

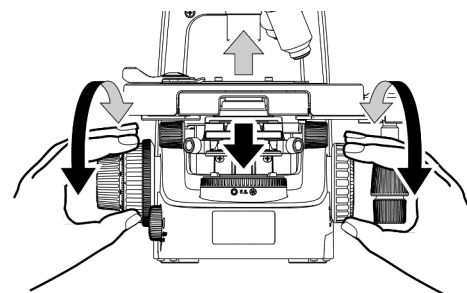

**Focus on the specimen.**

**9 Switch to bright-field microscopy.**

**(1) Darken diascope illumination, and then turn off diascope illumination.**

Turn the brightness control knob to darken diascope illumination. Then, press the illumination on/off button to turn off diascope illumination.

**(2) Insert the dark-field slider from the left side up to the click position, and bring the empty position into the optical path.**

The annular diaphragm is removed from the optical path, and the microscope is set to bright-field microscopy.

**!** Move your eyes away the eyepieces during position switching.  
Beware that if you remove the barrier filter from the optical path while looking into the eyepiece during dark-field microscopy, bright light might enter your eyes.  
When setting the microscope back to bright-field microscopy, either turn off diascope illumination or keep your eyes away from the eyepiece.

**(3) To continue observation, turn on diascope illumination.**

Press the illumination on/off button to turn on diascope illumination.



## 3

## Detailed Explanation

## 3.1 Turning the Power On and Off

## 3.1.1 Turn On/Off the Power to the Microscope

**Powering on the microscope**

Connect the AC adapter to turn on this microscope.

Connect the DC plug of the AC adapter to the DC IN connector on the rear of the product. Plug a power cord into the AC adapter's inlet for equipment, and the wall outlet.

When the power is turned on, the startup screen appears on the status display. Then, the control screen appears as usual.

**Powering off the microscope.**

To turn off the microscope, unplug the AC adapter.



Startup screen



Control screen

## 3.1.2 ECO Mode and SLEEP Mode

The ECO and SLEEP modes are used to put the microscope into the energy-saving state. During the energy-saving state in both modes, diascopic illumination and the LCD screen are turned off to save energy.

**ECO mode:**

When the microscope (turned on) is left idle for a specified period of time, the microscope is put into the energy-saving state. Long-press the brightness control knob to turn on or off the ECO mode (default: on). When the ECO mode is turned on, "ECO" is shown on the status display.

✓ **Setting the time to put the microscope into the energy-saving state.**

You can set how long the ECO mode waits before the microscope is put into the energy saving state from the SET UP screen (default: 15 minutes).

✓ **Observation through only eyepieces or long-term observation (without part operation)**

Turn off the ECO mode.

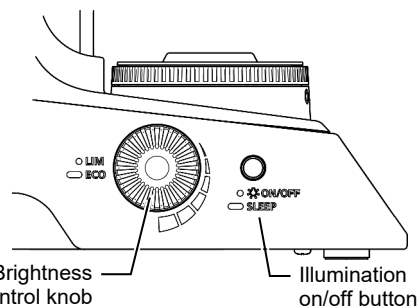
**Operating the brightness control knob**

- **Long-press:** Turn the ECO mode on or off.

**Operating the illumination on/off button**

- **Long-press:** Activate the SLEEP mode.

**SLEEP mode:**

The microscope can be put into the energy saving state anytime.

Long-press the illumination on/off button to immediately put the microscope into the energy-saving state.

**Recovery from the energy-saving state**

Perform the following to bring the microscope back to the normal operating state:

- Turn or press the brightness control knob.
- Press the illumination on/off button.
- Turn the nosepiece.

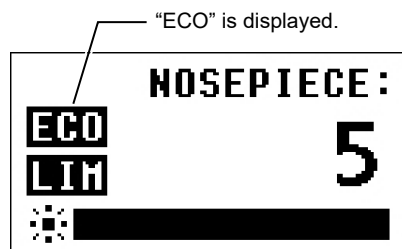

Control screen

## 3.2 Operating Diascopic Illumination

This microscope contains a diascopic illumination device using an LED light source.

### 3.2.1 Turning Diascopic Illumination On and Off and Adjusting the Brightness

#### Turning diascopic illumination on and off

To turn diascopic illumination on or off, use the illumination on/off button on the left side of the microscope.

Pressing the button once toggles illumination on or off. When illumination is on, the “on” symbol is shown on the status display.

#### Adjusting the brightness of diascopic illumination (brightness adjustment)

To adjust the brightness of diascopic illumination (brightness adjustment), turn the brightness control knob.

The illumination brightness (brightness state) is shown in a bar graph on the status display.

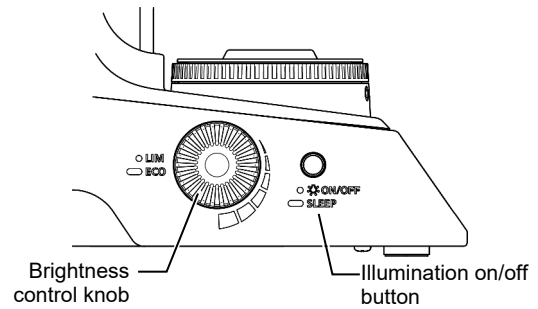

#### Operating the illumination on/off button

- **When pressed:** Toggles diascopic illumination on or off

#### Operating the brightness control knob

- **When turned:** Adjusts the brightness of diascopic illumination

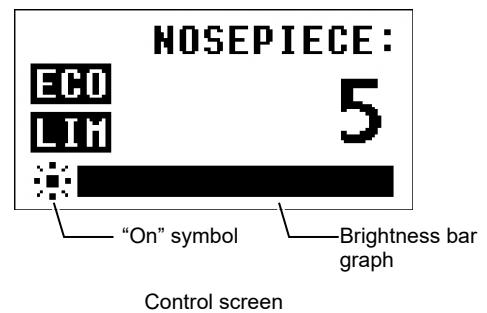

### 3.2.2 Using Light Intensity Management

This microscope features a light intensity management function (LIM).

To turn light intensity management on or off, briefly press the brightness control knob (the default setting is “on”).

When the light intensity management function is on, the brightness value for each position in the nosepiece is saved to the microscope's memory. The next time a position is brought into the optical path, the brightness value from the last time that position was used is automatically loaded.

When light intensity management is on, the “LIM” symbol is shown on the status display on the front of the microscope.

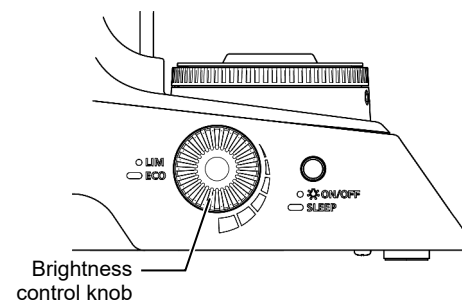

#### Operating the brightness control knob

- **When briefly pressed:** Turns light intensity management (LIM) on or off

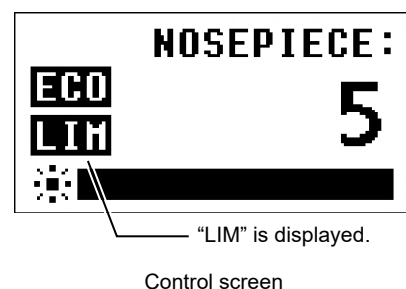

### 3.3 Operating the Stage Specimen Holder

#### 3.3.1 Placing a Specimen Using the Specimen Holder

Specimens are placed using the specimen holder installed on the stage.

- (1) Use the knob of the claw on the specimen holder to open the claw.
- (2) Place the specimen slide on the stage with the cover glass facing up.
- (3) Fix the specimen in place by returning the claw to its original position.

- ✓ **Placing a specimen**  
Two glass slides can be mounted on the specimen holder.
- ✓ **Cleaning the specimen**  
Clean the surface of the glass slide and the cover glass as necessary.

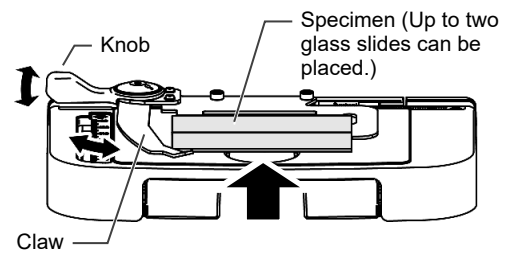

Placing a specimen using the specimen holder

#### 3.3.2 Operating the Stage

You can set the specimen fixed to the specimen holder to the desired position by operating the stage motion knobs to move the stage back and forth, and right and left. Set the specimen so that the region you want to observe is in the optical path.

The stage is capable of the following travel strokes:

- **Forward and back (top knob):** 52 mm
- **Left and right (bottom knob):** 76 mm

- ✓ **Travel scale**  
The stage has the scales that indicate the travel of the specimen in the horizontal and vertical directions. You can use the main scale and vernier scale to read the travel in units of 0.1 mm.

The end of the travel scale shows the icon of the stage motion knob to be operated.

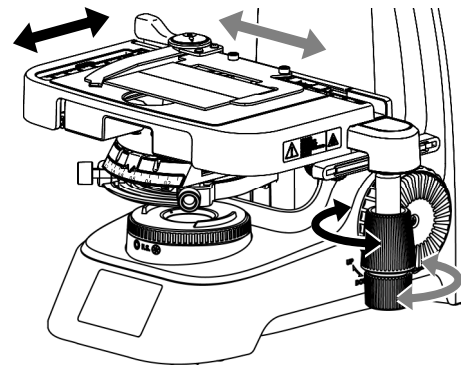

Operating the stage

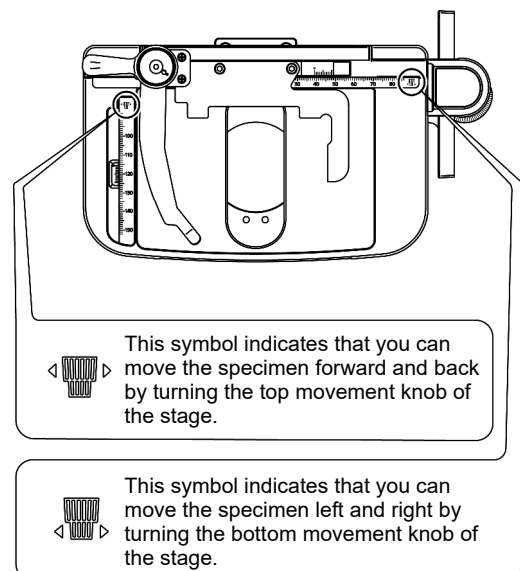

## 3.4 Operating the Nosepiece and Objectives

### 3.4.1 Switching Objectives

To switch objectives to use for observation, manually turn the turret ring of the nosepiece right or left until it reaches the click position.

Objectives are usually set in such an order that the objective magnification increases as the nosepiece is turned clockwise (as viewed from the top of the nosepiece).

- ✓ **When light intensity management is on**  
When the light intensity management function is turned on (LIM), bringing the objective into the optical path loads the memorized brightness.

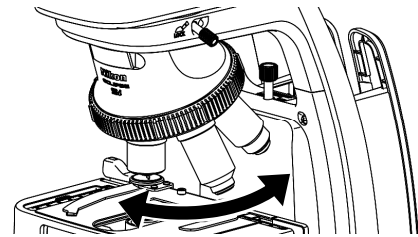

Operating the nosepiece

### 3.4.2 Oil-Immersion Observation

The “Oil” mark on the side of an objective indicates that it is an oil-immersion type objective. (The oil-immersion objective also has a black band around the barrel end.) An oil-immersion objective is used with the immersion oil applied between the front of the objective and the coverglass.

For an oil-immersion objective with a numerical aperture of 1.0 or more, also apply immersion oil to the condenser to take full advantage of its performance. (An oil-immersion type condenser needs immersion oil to be applied between the front of the condenser and the specimen.)

The condenser has an oil receptacle around the front of its lens.

#### Example of oil-immersion

Apply immersion oil to the condenser and then objective.

- **Condenser:**  
Add a drop of oil on the condenser lens, and then place the specimen on the stage.
- **Objective:**  
Rotate the revolving nosepiece to move the objective out of position. Add a drop of oil to the specimen. Slowly rotate the revolving nosepiece to bring the objective back into position.

#### Eliminating air bubbles

Make sure that air bubbles are not trapped during oil application. Air bubbles degrade the image.

Do any of the following to eliminate air bubbles:

- Rotate the revolving nosepiece to move the objective back and forth once or twice.
- Add another drop of oil.
- Wipe off the oil and apply again.

## Handling of the immersion oil

- Use a minimum quantity of oil. If too much oil is applied, surplus oil may flow out onto the stage and the condenser and degrade performance.
- Any oil residue left on the lenses of oil-immersion type objectives or adhesion of oils on the front lens of dry type objectives will degrade image quality. After completing oil-immersion observation, be sure to clean the objective, condenser, and any other parts that may be stained by oil.
- To wipe surplus oil on the front of the condenser lens, remove the condenser.
- Use petroleum benzine to wipe off oil and finish with absolute alcohol (ethyl or methyl alcohol). If petroleum benzine is not available, use methyl alcohol instead. In that case, wipe off the oil several times as the detergency of methyl alcohol is weaker than petroleum benzine. (You can wipe off the oil generally 3 to 4 times.)
- When handling petroleum benzine and absolute alcohol, be sure to follow the instructions described in “4. Handling flammable solvents” in “WARNING” at the beginning of this manual.
- Close the oil container cap tightly after use. Make sure that the cap is closed tight after refilling the container. Check the cap periodically to make sure it has not come loose, allowing oil to leak out.
- Do not press the container hard. Oil may splash out.
- If you find an oil drips around the container, wipe them off.
- Avoid contact of immersion oil with eyes or skin. In the event of contact with eyes or skin, take one of the following measures although Nikon immersion oil does not contain any toxic ingredients.
 

|                           |  |
|---------------------------|--|
| <b>Contact with skin:</b> | <b>Rinse your skin thoroughly with soap and water.</b>                               |
| <b>Contact with eye:</b>  | <b>Rinse your eye thoroughly with water (more than 15 minutes) and see a doctor.</b> |
- Do not leave immersion oil in the sun (ultraviolet rays may damage it).

### 3.4.3 Performing Water-Immersion Microscopy

The “WI” or “W” mark on the side of an objective indicates that it is a water-immersion-type objective. When using such an objective, perform water immersion (using distilled water or physiological saline) between the specimen and the front of the objective. Operate the microscope in the same way as for oil immersion.

Because water evaporates easily, make sure that the water is still present during observation. Beware that using large amounts of water might cause the water to overflow into the stage or condenser, causing corrosion.

#### ✓ **Cleaning up moisture**

After using the microscope, wipe any moisture off the surface of the objective. Then, perform a finishing wipe with absolute alcohol.

If evaporated moisture leaves a stain, gently wipe off the stain using a small amount of neutral detergent. Then, finish cleaning the surface by performing a finishing wipe with absolute alcohol.

## 3.5 Focusing Operations

### 3.5.1 Focusing on a Specimen

This procedure is to operate the fine and coarse focus knobs to raise and lower the stage so that the specimen to be observed can be seen most clearly.

The UP and DOWN indications on the sides of the microscope base indicate the direction in which the stage moves by rotation of the focus knobs. For both the fine and coarse focus knobs, turning in the UP direction raises the stage, and turning in the DOWN direction lowers the stage.

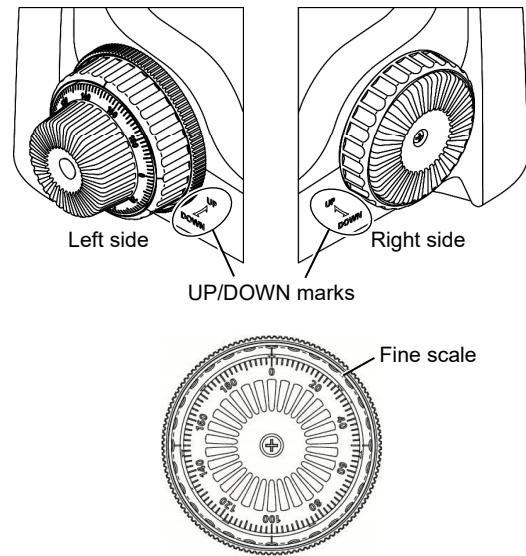

#### ✓ Fine scale

One rotation of the fine focus knob moves the stage vertically by 0.2 mm. Fine tick marks are placed at 2- $\mu$ m intervals of stage travel.

### Standard procedure

- (1) Swing the 10x (or 4x) objective into the optical path.
- (2) Rotate the coarse focus knob to raise the stage to its upper limit.

Since the working distances of 4x and 10x objectives are long, these objectives do not touch the specimen even when the stage is raised to its upper limit provided that the slide and coverglasses of a standard thickness are used. (The standard thickness for slide is 1.2 mm and that for coverglass is 0.17 mm.)

- (3) While looking into the eyepiece, slowly turn the coarse focus knob to lower the stage. When you find a position where the specimen is roughly in focus, let go of the coarse focus knob.

⚠ When rotating the coarse focus knob while looking into the eyepiece, be sure to rotate it in the direction that lowers the stage.

#### ✓ When the focal point cannot be found

To find the focal point, rotate the stage vertical movement stopper counterclockwise to unlock the limit.

- (4) Rotate the fine focus knob and precisely focus on the image.

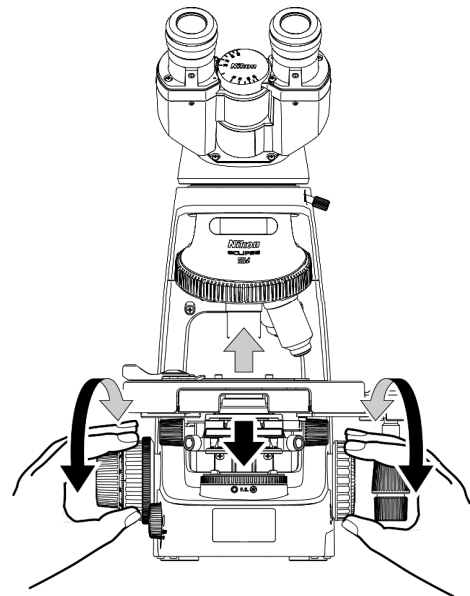

## Using the objective of a higher magnification for observation

First, use the 10x objective to focus on the specimen, and then change it to the desired objective and rotate the fine focus knob to precisely focus on the specimen.

**!** When operating the focus knob while using the objective of a higher magnification, care must be taken to prevent the slide glass from touching the objective. When you raise the stage using the coarse focus knob, look at the gap between the upper surface of the specimen and the front of the objective from the side.

## Using working distances

The stage can be raised by using the working distance of the objective.

While looking at the microscope from the side, carefully rotate the coarse focus knob to bring the specimen close to the objective. When the distance between the specimen and the front of the objective becomes slightly shorter than the working distance, let go of the coarse focus knob. The specimen is now almost in focus.

Look into the eyepieces and rotate the fine focus knob in the direction that lowers the stage to precisely focus on the specimen.

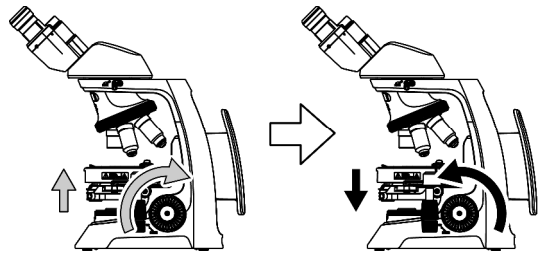

## Focusing by switching the objective from 40x to 10x

Swing the 40x objective into the optical path. While looking at the microscope from the side, rotate the coarse focus knob until the specimen almost touches the objective (about 0.5 mm apart from the front of the objective).

Switch to the 10x objective, look into the eyepieces, and rotate the fine focus knob slightly to find the focal point. Be careful not to hit the objective with the specimen.

### 3.5.2 Torque Adjustment of the Coarse Focus Knob

The tension (torque) of the coarse focus knob rotation can be adjusted.

To increase the tension, turn the coarse focus knob torque adjustment ring counterclockwise.

To decrease the tension, turn the ring clockwise. Do not decrease the tension too much. If it is too loose, the stage will fall under its own weight.

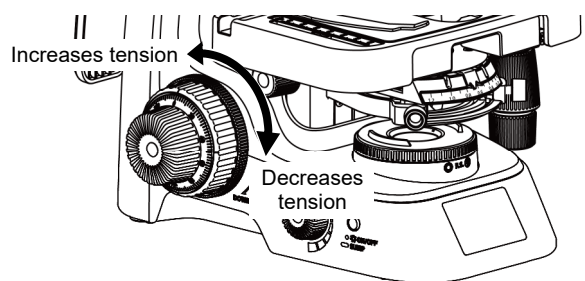

### 3.5.3 Replacing a Specimen Using the Stage Vertical Movement Stopper

When focusing on the specimen with 40x or higher magnification objective, you will find the specimen is brought very near to the objective (\*1).

At this time, special care must be taken to avoid damaging the specimen when replacing it. In a case like this, use the stage vertical movement stopper for easy specimen replacement.

The stage vertical movement stopper has the labels "FOCUS LIMIT", "HIGH", and "LOW", which show the direction of rotation and vertical movement. Operate the stage vertical movement stopper according to the following steps.

- (1) Turn the stage vertical movement stopper counterclockwise (in the HIGH direction) until it stops.
- (2) Focus on the specimen, and then turn the stage vertical movement stopper clockwise (in the LOW direction) until it stops. Rotating the stage vertical movement stopper too much causes the set focal point to shift.
- (3) Performing the above steps sets the stage so that it does not move above that position.
- (4) Lower the stage by the focus knob, and replace the specimen. After that, when turning the focus knob, you can find that the stage stops near the position set in (2).
- (5) If the specimen is out of focus, turn the stage vertical movement stopper counterclockwise (in the HIGH direction) to release the set position, and then slightly operate the fine focus knob to adjust the focus.

\*1: The distance between the front of the objective and the specimen when the specimen is in focus is called the "working distance" of the objective. See Section 3.10, "Microscope Terminology."

#### ✓ Operating the stage vertical movement stopper

Turn the stopper behind the microscope arm by fingers as shown in the figure below on the left.

If you cannot reach the stopper in this way, turn the stopper from the rear of the microscope arm as shown in the figure below on the right.

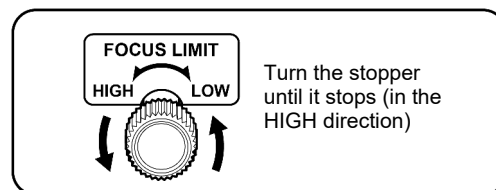
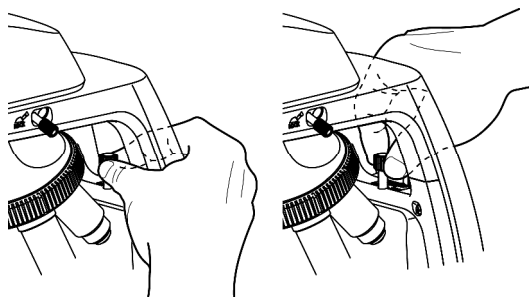

Turn the stopper until it stops (in the HIGH direction)

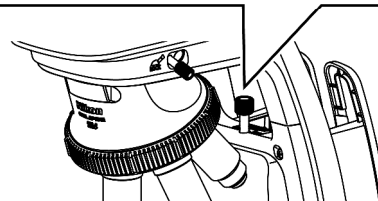

Turn the stopper until it stops (in the HIGH direction)

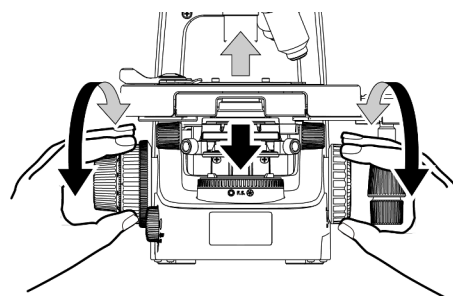

Focusing

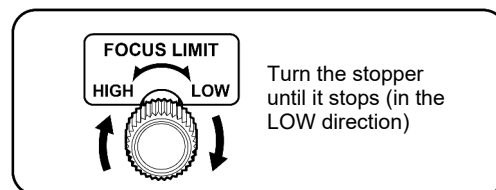

Turn the stopper until it stops (in the LOW direction)

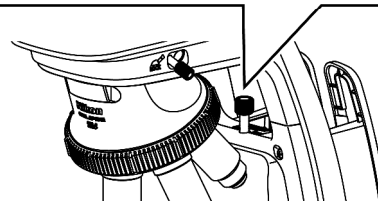

Turn the stopper until it stops (in the LOW direction)

When raising the stage by the focus knob, the stage stops near the focused position. The stage does not move above that position.



## 3.6 Operating the Binoculars

### 3.6.1 Adjustment of Diopter

This procedure is to adjust the diopter ring on the eyepieces according to the difference between your right and left eyesight.

✓ **Effect of diopter correction**

This adjustment enables the user to take full advantage of objective performance, and reduce loss of focus when switching magnifications.

- (1) **Turn each diopter ring on the right and left eyepieces to align the diopter ring's bottom edge with the engraved base line.**

This position is the base position for diopter adjustment.

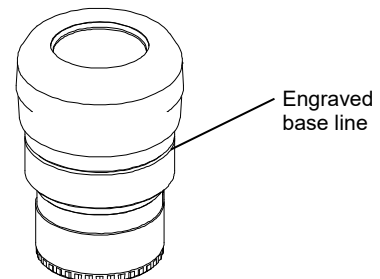

- (2) **Swing the 40x objective in the optical path. Rotate the coarse and then fine focus knobs to bring the specimen in focus. See the description in "■ Focusing by switching the objective from 40x to 10x" in Section 3.3, "Focusing."**

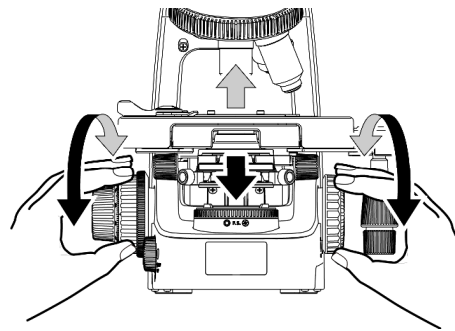

- (3) **Swing the 10x (or 4x) objective into the optical path.**

- (4) **While looking into the right eyepiece with your right eye, focus on the specimen by rotating the right diopter ring without using the focus knob.**

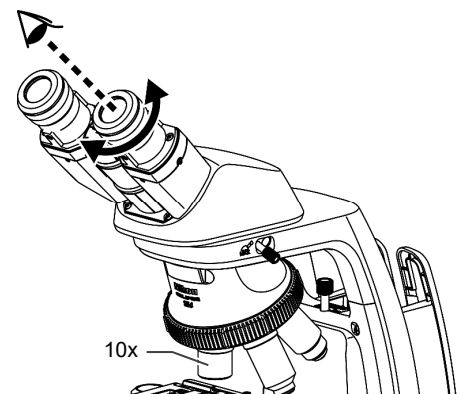

- (5) **While looking into the left eyepiece with your left eye, focus on the specimen by rotating the left diopter ring without using the focus knob.**

- (6) **Repeat steps (2) to (5) to check the specimen is in focus.**

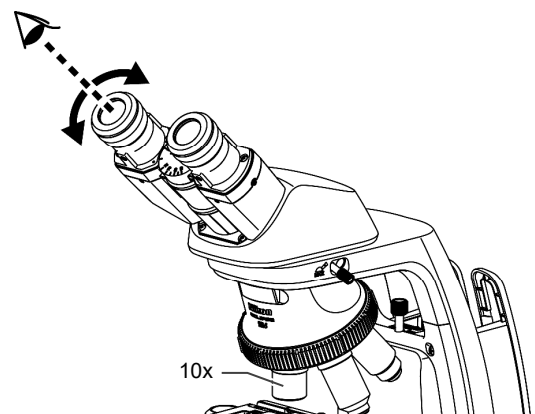

### 3.6.2 Adjusting Interpupillary Distance

“Adjusting interpupillary distance” means to adjust the distance between the eyepieces to match the distance between the observer’s eyes. Performing this adjustment makes it easier to observe specimens with both eyes.

#### Selecting an eye point

The binoculars of this microscope can be turned both upward and downward. To raise the eye point, turn the binoculars upward. To lower the eye point, turn the binoculars downward.

#### Adjusting interpupillary distance

After completing diopter adjustment of the eyepieces, bring the 10x objective into the optical path and focus on the specimen. Then, adjust the interpupillary distance of the binoculars so that looking into the eyepieces with both eyes results in a unified field of view.

#### ✓ Using the interpupillary distance scale lines

The binoculars are labeled with interpupillary scale lines. If you remember your own interpupillary distance, you can easily adjust the interpupillary distance the next time you use the microscope.

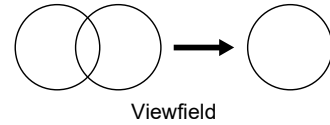
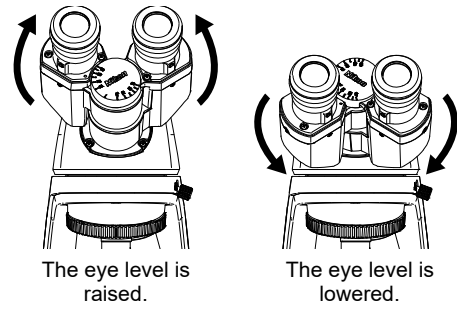

Adjusting interpupillary distance

## 3.7 Operating the Condenser

### 3.7.1 Focusing the Condenser

Adjust the vertical position of the condenser so that the field diaphragm image is clearly visible in the field of view.

**Caution: Do not raise the condenser too much.**

If you raise the condenser too much, the condenser lens might hit the specimen's glass slide, causing damage to the condenser lens or the glass slide.

When raising or lowering the condenser lens, be careful not to hit the specimen's glass slide.

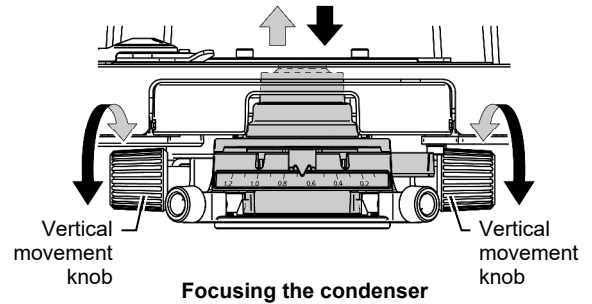

### 3.7.2 Centering the Condenser

Adjust the position of the condenser so that the illumination is correctly centered in the field of view. This operation is called “centering the condenser.”

You can adjust the position of the condenser by turning the condenser centering knobs on each side of the aperture diaphragm lever.

#### Adjusting the position of the condenser

Bring the 10x objective into the optical path, narrow the field of view, and adjust the position of the condenser so that the field diaphragm image is centered in the field of view.

When performing strict position adjustment, bring a higher-magnification objective into the optical path and perform centering as usual.

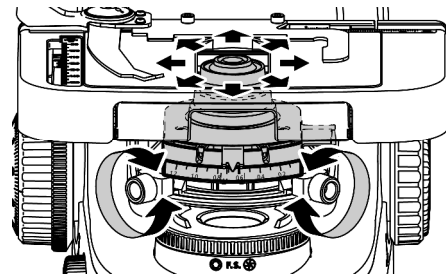

Centering the condenser

### 3.8 Adjustment of Aperture Diaphragm

The size of the condenser aperture diaphragm must be adjusted according to the NA value of the objective in the optical path.

The condenser is labeled with an adjustment position mark for the aperture diaphragm, which serves as a guideline for the adjustment position. Turn the aperture diaphragm lever to the same number as the NA value of the objective in the optical path.

Each time you change the objective magnifications, align the aperture diaphragm lever to the same figure as the magnifying power of the objective.

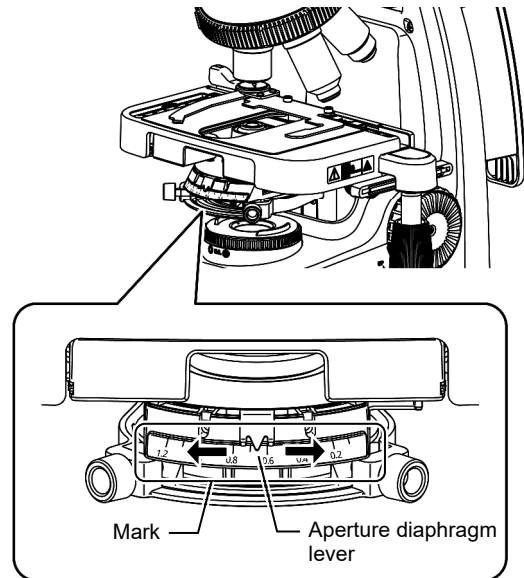

Adjustment position mark for the aperture diaphragm

#### ✓ Aperture Diaphragm

- The aperture size is increased or decreased by turning the condenser aperture diaphragm lever. If the aperture diaphragm is closed, the brightness and resolution are decreased but the contrast and range of focus are increased. If the aperture diaphragm is opened, the brightness and resolution are increased but the contrast and range of focus are decreased. Since the image resolution will be degraded when the aperture diaphragm is closed too much, do not close the aperture diaphragm too much except when observing a specimen with extremely low contrast, such as a near-transparent specimen.
- The aperture diaphragm controls the numerical aperture of the illumination. Do not use it to control brightness. Use the brightness control knob to control the brightness.



- E PLAN → Objective type
- 40x/0.65 → Magnification 40 times/Numerical aperture 0.65
- $\infty$ /0.17 → Mechanical tube length  $\infty$ /Coverglass thickness 0.17 mm
- WD 0.65 → Working distance (Distance between the tip of the objective and the specimen) 0.65 mm

#### Specifications of objective

### 3.9 Adjustment of field diaphragm

“Adjusting the field diaphragm” means narrowing the illumination to limit the field of observation of the specimen.

To resize the field diaphragm, turn the field diaphragm dial. Usually, observation is performed with the field diaphragm narrowed until it roughly circumscribes the edge of the field of view.

Note that the field diaphragm cannot be narrowed to inside field of view when using a 60x or higher magnification objective.

✓ **Optimum size of the field diaphragm**

Usually, the optimum size is when the field diaphragm roughly circumscribes the edge of the field of view.

If the field diaphragm is opened too wide, causing an unnecessarily wide field of illumination, stray light enters from the outside, resulting in flares and reducing the contrast of the optical image.

This also causes the specimen's discoloration field to become too wide.

✓ **Adjustment of field diaphragm**

Each time you change the objective, adjust the field diaphragm.

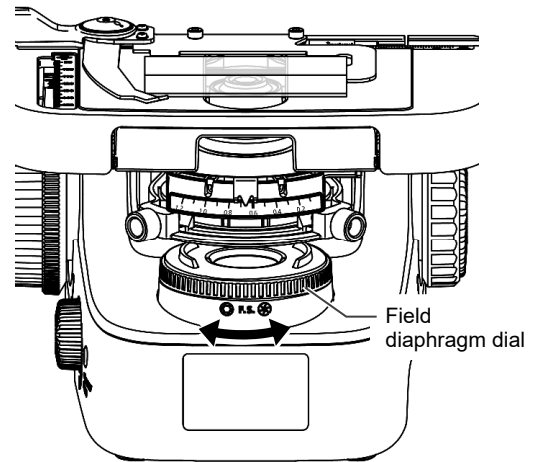

**Adjustment of field diaphragm**

## 3.10 Tips for Each Microscopy Method

### 3.10.1 Tips for Phase Contrast Microscopy

Phase contrast microscopy is suited for observing colorless and transparent specimens, unstained or lightly stained specimens, specimens that have lost their color, and ultra-thin sections for electron microscopes. Shaded or strongly stained specimens are not suited to phase contrast microscopy.

The appearance of the phase contrast image is influenced by factors such as the phase difference or shape of the specimen and the characteristics of the objective. Be careful of the following when preparing specimens and selecting Ph objectives.

#### Select specimens that do not de-center the Ph annular diaphragm.

When light-scattering specimens or specimens that have a lens or prismatic effect are observed, the Ph annular ring becomes de-centered. Special care is needed with specimens such as thick live specimens, coarse specimens, and specimens using microplates, which affect the lens or prism and de-center the Ph annular ring, worsening the image.

#### Ph objectives and specimens

Ph objectives can be divided into “achromat”, “plan achromat”, “plan fluor”, and “plan apochromat” objectives depending on their chromatic aberration and degree of field curvature correction. These lenses can also be divided into several types depending on the characteristics of their internal phase ring. Satisfactory results cannot be achieved if the specimen's degree of phase difference or the characteristics of the phase ring are unsuitable. For details on the characteristics of the use of phase contrast objectives, see the following table.

- When using a Ph objective for dark contrast, make sure the specimen's phase difference does not exceed the objective's degree of tolerance (latitude) for phase difference. If the specimen's degree of phase difference exceeds the degree of tolerance for phase difference, the image shines more brightly than the background, making observation impossible.
- When preparing a phase-difference specimen, you can adjust the phase difference by changing the refractive index, for example by changing the specimen thickness, mounting agent, or culture fluid.
- Even specimens that appear in low contrast when observed using a DLL objective might yield good results when observed using a DM objective.

Characteristics of the use of phase contrast objectives

| Phase contrast objective |           | Appearance of image  | Contrast   |   | Latitude   | Example of application   |
|--------------------------|-----------|--|--|---|--|--|
| Dark contrast            | DLL<br>DL | Generally, objects with a large phase difference appear dark. Accordingly, the image appears blackened in a comparatively bright field of view, resulting in a similar image to bright-field microscopy. | Dark contrast is suited to detailed observation, mainly via micro-contrast.  | Halftones (wide scope of use)                           | Low- and mid-range phase difference and absorptive objects (stained objects) | Fungal spores, general live cells, slightly thick specimens, bacteria, stained specimens, insect eggs, fat globules, crystals, and the like            |
|                          | DM        |  |  | High-contrast tones (comparatively narrow scope of use) | Low-range transparent objects  | Bacterial or protozoan flagella, fibrin fibers, fine granules, sections with appropriately selected mounting agents, ultra-thin sections, and the like |
| Bright contrast          | BM        | Generally, objects with a large phase difference appear bright. Accordingly, the image appears brightened in a comparatively dark field of view, resulting in a similar image to dark-field microscopy.  | Bright contrast is suited to observing the forms of detailed fibers or granules, detection, or calculation, mainly via macro-contrast. |   | Mostly full-range  | Bacterial or protozoan flagella, fibrin fibers, fine granules, blood-count calculation, and the like   |

## Notes on limits on objectives

---

When a phase contrast slider's bright-field position is used, the following limits apply depending on the objective:

- For objectives of NA 0.75 or higher, part of the field of view is lost (vignetting occurs).
- For objectives of NA 0.95 or higher, loss of field of view caused by vignetting, or reductions in peripheral light intensity occur.

Note that when a phase contrast slider's bright-field microscopy position is used, the following limits apply depending on the objective:

- For PH sliders (10x/40x): PH1: NA 0.25 - 0.5, PH2: NA 0.55 - 0.85
- For PH sliders (100x): PH3: NA 0.9 - 1.4

## Phase contrast slider

---

Phase contrast microscopy requires a phase contrast slider with a mounted Ph annular diaphragm. A phase contrast result can be obtained by correctly matching the Ph annular diaphragm and the phase ring of the Ph objective.

### Ph code

Ph objectives are labeled with a Ph code according to the size of the phase ring. The code can be [Ph1], [Ph2], or [Ph3]. To use a Ph objective, bring the Ph annular diaphragm that has the same code as the Ph objective's Ph code into the optical path. If you use a Ph annular diaphragm with a different Ph code from the Ph objective, a phase contrast result cannot be obtained.

### Aligning an annular diaphragm and phase ring

The phase contrast image is subtly affected by overlap between the annular diaphragm and phase ring. When performing strict observation or photography, confirm that the annular diaphragm and phase ring are concentric for each magnification.

Adding slight eccentricity to the annular diaphragm and phase ring creates a shadowing effect, producing a three-dimensional image. Use this technique as required by the specimen.

## Using GIF filters

---

The contrast of a phase contrast image is improved by bringing a GIF filter (green interference filter) into the optical path. GIF filters are installed on top of the field lens.

### 3.10.2 Tips for Simple Polarizing Microscopy

Simple polarizing microscopy is an observation method for measuring polarization, refraction, and other states of the specimen by bringing the analyzer and polarizer into the microscope's optical path to limit the light's vibration direction.

Of the polarizing microscopy methods, this microscope only supports simple polarizing microscopy. Polarizing microscopy using sensitive color is not supported.

## Operating the polarizer

---

- Setting the polarizer to a horizontal orientation causes the analyzer and polarizer orientations to converge at a right angle. This state is known as "crossed Nicol."
- When the polarizer is removed and only the analyzer is brought into the optical path, this state is known as "open Nicol."

### 3.10.3 Tips for Diascopic Fluorescence Microscopy

Diascopic fluorescence microscopy is a microscopy method for using diascopic illumination to examine specimens stained with fluorescent dye or fluorescent protein. You can observe excited fluorescence as an image by directing diascopic illumination of a particular wavelength at objects stained with special fluorescent dye.

#### Purpose of diascopic fluorescence microscopy

This microscope can be used for observation by diascopic fluorescence (GFP-B) by using the E2-F-FI diascopic fluorescence filter set (GFP-B). You can perform observation using GFP, FITC, Alexa 488, and more.

✓ **Note on the brightness of excited fluorescence**

The brightness of fluorescent light excited during diascopic fluorescence microscopy might be reduced, for example due to the expression efficiency of the sample GFP.

Generally, excited fluorescent light is extremely faint.

When performing fluorescence microscopy, darken the area around the microscope, for example by turning down the ambient light so that you can observe the specimen correctly.

#### Note on eye protection during slider operation

Move your eyes away from the binoculars during position switching of EX filter sliders.

Fluorescence microscopy is performed with diascopic illumination set to maximum. Therefore, bright light might reach the binoculars when the position of the fluorescence microscopy slider is switched.



**Do not remove the slider.**

**Never remove the EX filter slider from the microscope during diascopic fluorescence microscopy.**

#### Preventing UV light (using a shielding plate)

Use the shielding plate to prevent strong light including UV light from the specimen through the condenser from entering your eyes.

#### Protecting specimens and preventing discoloration

Brightly illuminating a specimen for fluorescence microscopy for an extended time might cause damage or discoloration of the specimen.

When stopping diascopic fluorescence microscopy, either turn off the illumination or lower the brightness. Make this a habitual practice.

#### Using non-fluorescent glass slide, a cover glass, and immersion oil

To obtain an image with good contrast during fluorescence microscopy, make sure that you use non-fluorescent glass slide, a cover glass, and an immersion oil specified by our company.

#### Limiting illumination to the field of observation (adjusting the field diaphragm)

“Adjusting the field diaphragm” means narrowing the illumination to limit the field of observation of the specimen.

Usually, observation is performed with the field diaphragm narrowed until it roughly circumscribes or inscribes the edge of the field of view. If the field diaphragm is opened too wide, causing an unnecessarily wide field of illumination, stray light enters from the outside, resulting in flares and reducing the contrast of the optical image. This also causes the specimen's discoloration field to become too wide.

Each time you change the objective, adjust the field diaphragm.

#### Finding targets inside the specimen

For fluorescence microscopy, the general practice is to first use phase difference to find a target and then switch to using fluorescence microscopy. However, when finding targets using bright-field microscopy, you will need to take the following kinds of measures:

- In bright-field microscopy, first use a 10x objective, and then narrow the condenser as required.
- If raising the magnification makes it difficult to find the target, switch to fluorescence microscopy, and then find the target while suppressing the excitation light.

Another method is to work while looking at the edge plane of the cover glass to identify the rough position of the target.



### 3.10.4 Tips for Dark-field Microscopy

#### Notes on limits on objectives

---

Objectives that can be used for dark-field microscopy are limited to the following:

- **For dark-field microscopy:** NA 0.65 or lower
- **For observation using a bright-field position:** NA 1.25 or lower

✓ **Note on the bright-field position of the dark-field slider**

Objectives that can be used in the bright-field position of the dark-field slider have different conditions than for regular bright-field microscopy.

With objectives of NA 1.0 or higher, vignetting might occur in the periphery, causing the image to darken.

#### Note on eye protection during slider operation

---

Move your eyes away from the binoculars during position switching of dark-field sliders.

When you switch from a dark field to a bright field, bright light might reach the binoculars.

## 3.11 Combinations of Optical Parts

### Compatibility between objectives and microscopy methods

#### Compatibility between optical parts and microscopy methods

| Objective                | Magnification | Bright-field | Phase Contrast | Simple Polarizing | Diascopic Fluorescence | Dark-field |
|--------------------------|---------------|--------------|----------------|-------------------|------------------------|------------|
| E Plan 4x                | 4x            | S            | -              | U                 | S                      | -          |
| E Plan 10x               | 10x           | S            | -              | U                 | S                      | U          |
| E Plan 40x               | 40x           | S            | -              | U                 | S                      | S          |
| E Plan 60x               | 60x           | S            | -              | U                 | -                      | -          |
| E Plan 100x Oil          | 100x          | S            | -              | U                 | -                      | -          |
| Achromat DL 10x Ph1      | 10x           | S            | R              | U                 | U                      | U          |
| Achromat DL 20x LWD Ph1  | 20x           | S            | R              | U                 | U                      | S          |
| Achromat DL 40x Ph2      | 40x           | S            | R              | U                 | U                      | S          |
| Achromat DL 100x Oil Ph3 | 100x          | S            | R              | U                 | -                      | -          |

(R: Recommended; S: Suitable; U: Usable; -: Incompatible)

✓ **20x objectives for bright-field microscopy**

Plan 20x objectives can be used for bright-field microscopy with 20x magnification.

### Combinations of objectives and 10x (field number 20) eyepieces

#### Compatibility between optical parts and microscopy methods

| Objective                | Magnification | Total Magnification (x) | Numerical Aperture | Real Field (mm) | Depth of Focus ( $\mu\text{m}$ ) | Resolving Power ( $\mu\text{m}$ ) | Working Distance (mm) |
|--------------------------|---------------|-------------------------|--------------------|-----------------|----------------------------------|-----------------------------------|-----------------------|
| E Plan 4x                | 4x            | 40                      | 0.1                | 5               | 115                              | 2.8                               | 30.00                 |
| E Plan 10x               | 10x           | 100                     | 0.25               | 2               | 18.4                             | 1.1                               | 7.00                  |
| E Plan 40x               | 40x           | 400                     | 0.65               | 0.5             | 2                                | 0.4                               | 0.65                  |
| E Plan 60x               | 60x           | 600                     | 0.8                | 0.3             | 1.2                              | 0.3                               | 0.3                   |
| E Plan 100x Oil          | 100x          | 1000                    | 1.25               | 0.2             | 0.7                              | 0.2                               | 0.23                  |
| Achromat DL 10x Ph1      | 10x           | 100                     | 0.25               | 2               | 18.4                             | 1.1                               | 7.00                  |
| Achromat DL 20x LWD Ph1  | 20x           | 200                     | 0.40               | 1               | 6.1                              | 0.7                               | 3.9                   |
| Achromat DL 40x Ph2      | 40x           | 400                     | 0.65               | 0.5             | 2                                | 0.4                               | 0.65                  |
| Achromat DL 100x Oil Ph3 | 100x          | 1000                    | 1.25               | 0.2             | 0.7                              | 0.2                               | 0.23                  |

## 3.12 Microscope Terminology

### (1) Total Magnification

The total magnification of a microscope is the individual magnifying power of the objective multiplied by that of the eyepiece.

### (2) Numerical Aperture (N.A.)

The numerical aperture is an important factor in determining the efficiency of the condenser and objective. It is represented by the formula:

$$N.A. = n \sin \alpha$$

where  $n$  is the refractive index of the medium (air, immersion oil, etc.) between the objective and the specimen or condenser, and  $\alpha$  is the maximum angle at which light enters or leaves the lens from or to a focused object point on the optical axis.

The larger the numerical aperture the brighter the image and the higher the resolution.

### (3) Resolving power

The ability of an optical system to discriminate between two discrete objects separated by a minute distance. The more minute the distance, the higher the resolving power of the optical system. In relation to the numerical aperture, the resolving power is represented by the following formula:

$$\text{Resolving power} = \frac{\lambda}{2 \times N.A.} \quad \lambda: \text{Wavelength}$$

(The resolving power in the above table is indicated for  $\lambda = 0.55 \mu\text{m}$ .)

### (4) Working Distance (W.D.)

The clearance between the front of the objective and the upper surface of the coverglass, when a specimen image is sharply focused. Generally, the higher the magnifying power of the objective, the shorter the working distance.

### (5) Field Number of the Eyepiece

The diameter in mm of the viewfield observable through the eyepiece. When an eyepiece has an indication of "10x / 20", it means that the magnification is 10x and the field number is 20 for that eyepiece.

### (6) Real Viewfield

The diameter of the region of the specimen that is actually observed with the microscope.  
Real viewfield = field number of eyepiece / magnification of objective

### (7) Depth of Focus

The depth (thickness) of the specimen image in focus, extending above and below the focused image plane. The larger the N.A. of the objective, the shallower the depth of focus.

$$DOF = n \times \left( \frac{\lambda}{2 \times N.A.^2} + \frac{250000 \times \omega}{M \times N.A.} \right)$$

$DOF$  : Depth of focus (object side)

$n$  : Refractive index (according to the medium between the specimen and objective)

If the medium is air: 1

If the medium is immersion oil (Nikon Immersion Oil): 1.518

$\omega$  : Resolving power of the eye (assumed to be  $5' = 0.0014$ )

$M$  : Total magnification

$N.A.$  : Numerical aperture of objective

$\lambda$  : Wavelength (for visual observation, assumed to be  $0.55 \mu\text{m}$ )

### (8) Excitation filter

Of the light illuminating the specimen, an excitation filter allows only the wavelengths of light necessary to emit fluorescence from the specimen to pass through. The term "excitation filter" refers to the excitation of fluorescence in this process.

### (9) Barrier filter

A barrier filter allows only the wavelengths of light consisting of excited fluorescence to pass through. The term "barrier filter" is used because the filter acts as a barrier absorbing non-fluorescent light.

# 4

# Assembly

This chapter explains how to assemble the microscope.

Before assembling or connecting devices, thoroughly read the “Safety Precautions” and “Notes on Handling the Product” at the beginning of this manual, and make sure that you follow all the instructions written therein.

**Tools required for assembly:** Hexagonal wrench (with a 3-mm distance between opposite sides) (One hexagonal wrench is provided with the microscope.)

## 4.1 Configuration Diagrams

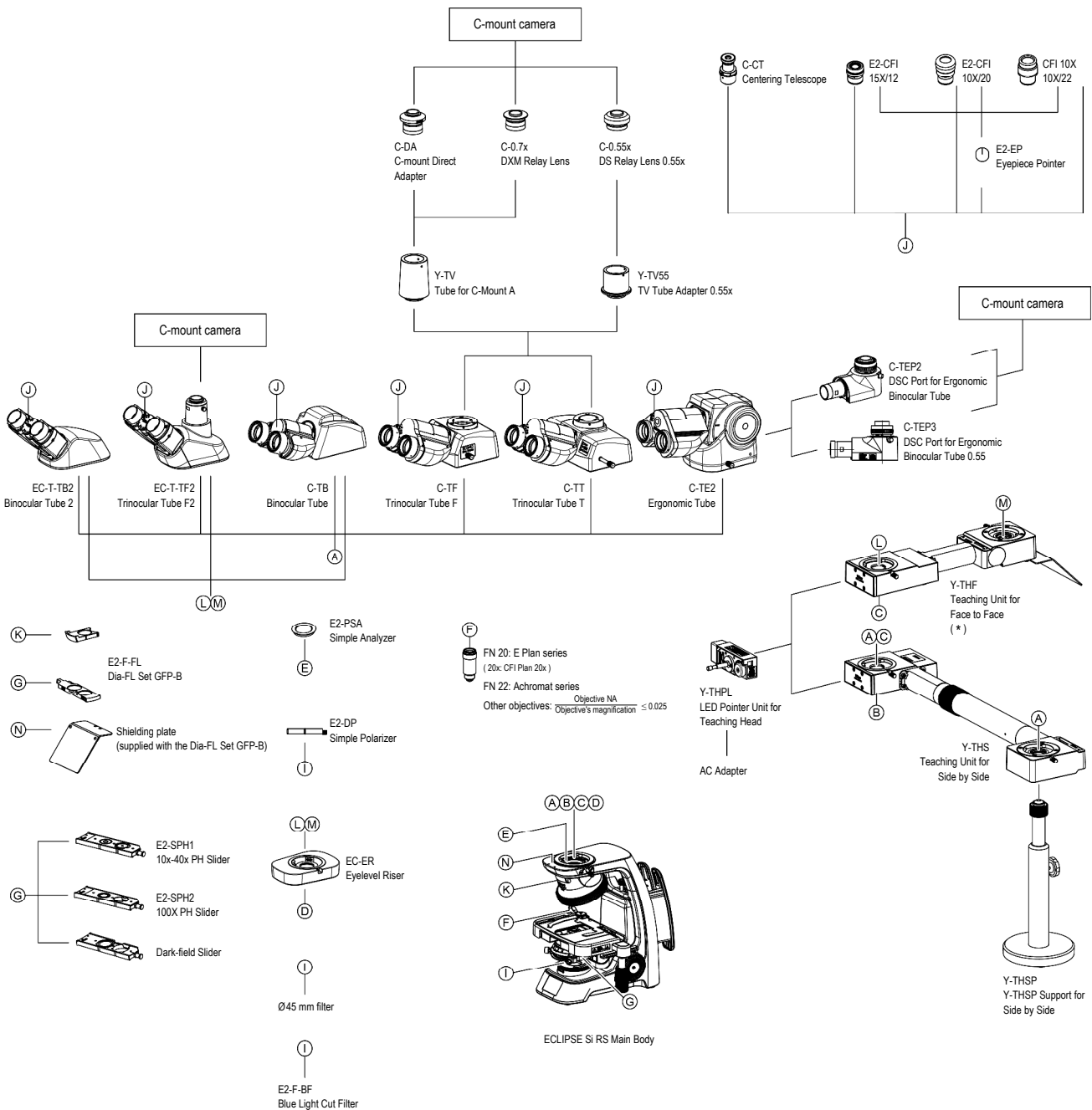

\* When mounting eyepiece tubes on the teaching unit for face to face, be sure that the weight of (L) is equal to or heavier than (M).

## 4.2 Assembly

This chapter explains the microscope assembly procedure for each microscopy method.

Before assembling or connecting devices, thoroughly read the “Safety Precautions” and “Notes on Handling the Product” at the beginning of this manual, and be sure to follow all the instructions written therein.

Tools Required for Assembly: Hexagonal wrench (the distance between opposite sides is 3 mm) (one hexagonal wrench is provided with the microscope)

### 4.2.1 Basic Configuration (for Bright-field Microscopy)

#### (1) Removing the fastening plate

Remove the red fastening plate attached to the top of the stage.

The fastening plate retains movement in the front and back directions of the stage and is attached with two bolts. Remove this fastening plate with the hexagonal wrench provided.

✓ **Keeping the fastening plate**

Be sure to keep the fastening plate with two bolts just in case re-fastening is needed.

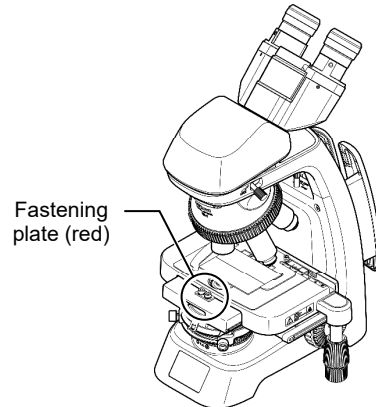

#### (2) Changing the direction of the eyepiece tube, removing and attaching the eyepiece tube

When you have purchased the microscope as a set, the eyepiece tube is already installed to the main body.

At the time of observation, turn the binoculars toward you and fix the eyepiece tube. At the time of storage, turn the binoculars backward and fix the eyepiece tube.

When changing the direction of the eyepiece tube, or replacing the eyepiece tube to another one, follow the following procedure.

When installing the eyepiece tube to the main body for the first time, also follow the procedure described in “Installing the eyepiece tube.”

#### Changing the direction of the eyepiece tube

Manually rotate the fixing screw for the eyepiece tube a couple of turns to loosen it while supporting the eyepiece tube by finger. Turn the eyepiece tube in the desired direction and securely tighten the fixing screw for the eyepiece tube while the eyepiece tube fits into the round dovetail mount properly.

✓ **Mark of the direction in which to fix the eyepiece tube for storage**

The microscope has an icon on the arm that indicates the direction in which to fix the eyepiece tube when storing the microscope. This mark indicates that the binoculars of the eyepiece tube is turned backward and fixed.

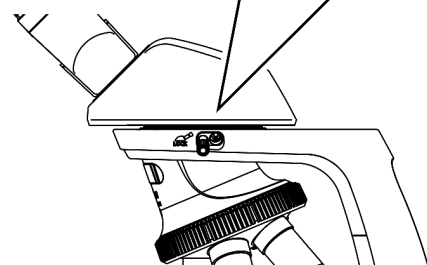
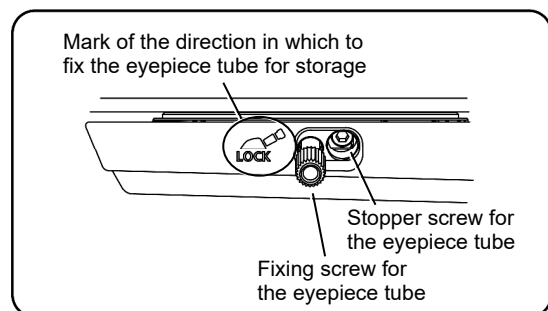

#### Removing the eyepiece tube

Manually loosen the fixing screw for the eyepiece tube while supporting the eyepiece tube by hand.

Then, loosen and remove the stopper screw for the eyepiece tube by using the supplied hexagonal wrench. Remove the eyepiece tube with care not to drop it.

### Installing the eyepiece tube

Insert the eyepiece tube into the circular dovetail mount while tilting it so that the eyepiece tube fits into it properly. Securely tighten the fixing screw for the eyepiece tube while supporting the eyepiece tube by hand.

Fit the stopper screw for the eyepiece tube, and tighten the screw by using the supplied hexagonal wrench.

✓ **Purpose of the stopper screw for the eyepiece tube**

The stopper screw for the eyepiece tube is for preventing the eyepiece tube from falling when the fixing screw for the eyepiece tube is loosened. The eyepiece tube cannot be fastened with only the stopper screw for the eyepiece tube.

✓ **When screws are attached**

If you purchase the microscope without the eyepiece tube, the fixing screw and stopping screw for the eyepiece tube are fitted into the screw holes and taped to prevent them from falling out. When installing the eyepiece tube, peel off the tape and remove the two attached screws, and then follow the procedure described in "Installing the eyepiece tube."

✓ **When using an eye-level riser**

You can raise the eye point by 25 mm by attaching an eye-level riser between the microscope main body and the eyepiece tube.

While tilting the eye-level riser, fit it into the microscope's circular dovetail mount. Fasten the eye-level riser by using your fingers to tighten the fixing screw for the eyepiece tube. Then, tighten the stopper screw for the eyepiece tube by using the supplied hexagonal wrench.

Attach the eyepiece tube to the round dovetail mount on the upper surface of the eye-level riser. Perform the attachment correctly according to the aforementioned procedure.

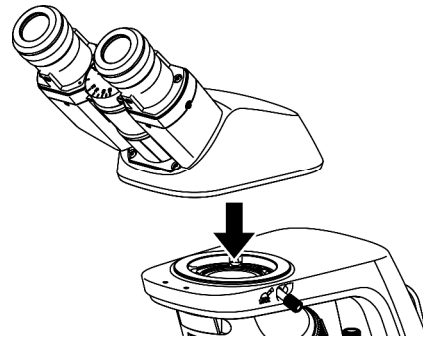

Installing the eyepiece tube

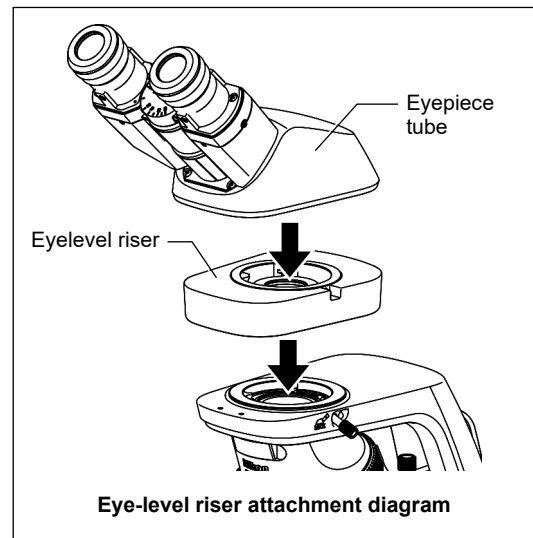

Eye-level riser attachment diagram

### (3) Attaching the camera mount

The camera mount (C mount) is attached to the camera port of the trinocular eyepiece tube.

Loosen the knurled screw on the camera port and remove the cap and C mount. Photomicrography becomes available after attaching the C mount to the camera, and then attaching it to the camera port.

The optical path of the trinocular eyepiece tube is fixed at the ratio: binoculars : camera port = 50 : 50.

For details about photomicrography, refer to the instruction manual of the camera.

✓ **Camera mount cap**

Do not lose the cap.

When you do not attach the camera, make sure that the cap is placed on the camera port.

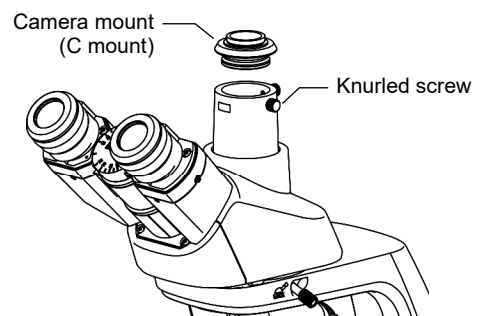
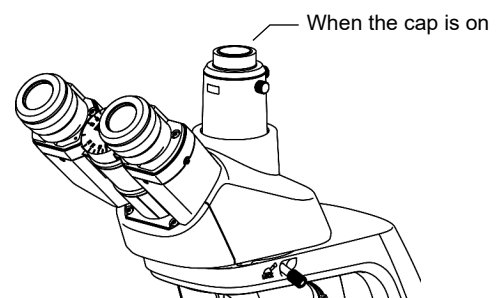

Attach the camera mount

#### (4) Installing the eyepieces

The 10x (Field No. 20) eyepieces are attached to the eyepiece tube before shipment.

When changing to a 15x (Field No. 18) eyepiece (optional), be sure to change both the right and left eyepieces together. The right and left eyepieces should be of the same magnification.

##### ✓ Replacement of eyepieces

To remove the eyepieces, loosen the fixing screws for the eyepieces. The microscope does not come with a hexagonal wrench (the distance between opposite sides is 2.5 mm) to loosen the fixing screws. Contact your nearest Nikon representative if you have any questions.

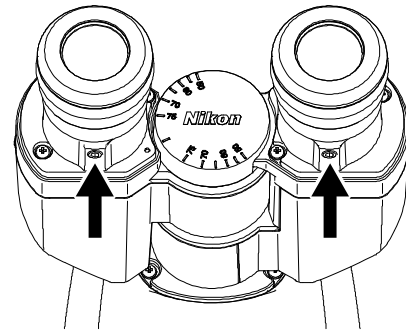

Installation of the eyepieces

#### (5) Installing the objective

Screw an objective into the revolving nosepiece. Screw the objective firmly to the end.

First, remove the specimen from the stage and lower the stage. Remove the objective while holding it by both hands so that it does not fall, and then install a new objective.

Set the objectives in such an order that the objective magnification increases as the revolving nosepiece is turned clockwise (as viewed from the top of the microscope).

##### ✓ Installation order of the objectives

When you have purchased the microscope as a set, three objectives are already installed to the revolving nosepiece. When adding an objective or replacing the objective with another one, also install it in the magnification order as described above.

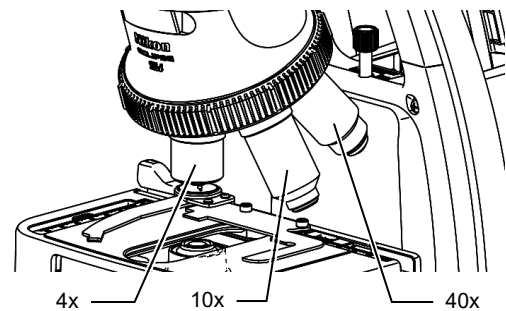

Example of order of installing the objectives

#### (6) Installing the condenser

The condenser is attached to the microscope before shipment. The condenser is fastened by a leaf spring, allowing attachment or removal without the use of tools.

When attaching or removing the condenser, raise the stage to its maximum height, and lower the condenser to its minimum height.

The condenser can be removed by pulling it towards you.

To attach the condenser, fit it into the dovetail at the mount, and push the condenser in all the way.

##### ✓ Note on removing the condenser

If you pull out the condenser with the centering screw fully loosened, the inner frame of the condenser mount may be removed together. In this case, put the inner frame back to the dovetail, and then tighten the centering screw. Centering work after reattaching the condenser can be performed without problem.

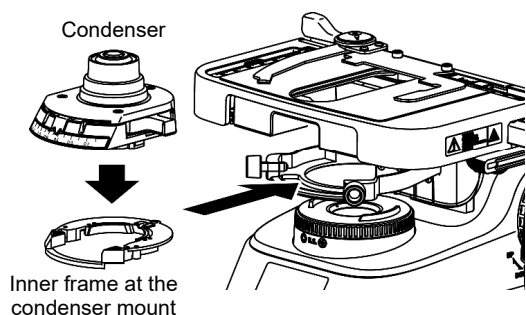
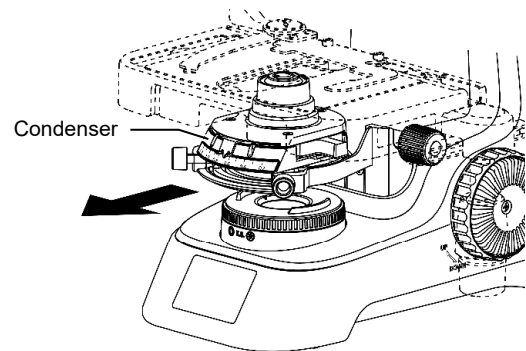

If the inner frame is accidentally removed

## (7) Connecting the AC adapter and power cord

Plug the power connector of the specified power cord into the AC adapter's inlet for equipment.

For details on the specified power cord, see Chapter 7, "Specifications."

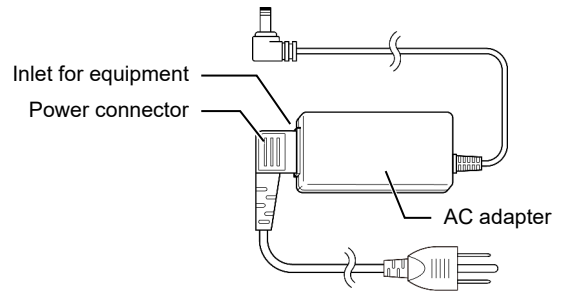

## (8) Other components

### 1) Eyepiece Pointer

The eyepiece pointer (optional) serves as a reference for pointing out the specimen to be observed. Attach the pointer to one of the eyepieces. Rotate and remove the viewfield ring from the eyepiece end.

Attach the eyepiece pointer to the eyepiece and then put back the viewfield ring.

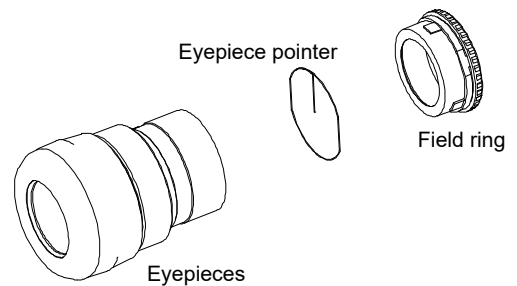

### 2) Filter Receptacle and Filters

Two  $\varnothing 45$ -mm filters can be placed on the upper surface of the field lens. (If the thickness is more than 2.5 mm, only one filter is allowed.)

### 3) Centering telescope

Attach the binoculars when adjusting the annular diaphragm position.

When using the centering telescope, remove one eyepiece from the binoculars and attach the centering telescope in its place.

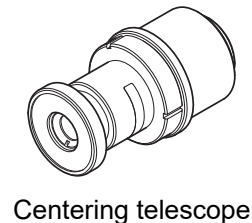



## 4.2.2 Configuration for Phase Contrast Microscopy

When performing phase contrast microscopy, assemble the microscope in the basic configuration for bright-field microscopy, and then attach the following optical parts to the microscope:

### (1) Phase contrast sliders

There are two kinds of phase contrast sliders: Slider for 10x-40x and slider for 100x). Objectives that can be used are limited to the following:

Supported objectives for phase contrast sliders

| Phase contrast slider | Objective |              |
|-----------------------|-----------|--------------|
|                       | PH code   | Supported NA |
| For 10x to 40x        | PH1       | 0.25 to 0.5  |
|                       | PH2       | 0.55 to 0.85 |
| For 100x              | PH3       | 0.9 to 1.4   |

### (2) Phase contrast objective (Ph objective)

Attach an objective with a PH code to the nosepiece. See (5) Installing the objective in “4.2.1 Basic Configuration (for Bright-field Microscopy).”

#### ✓ Combination of optical parts

Confirm in advance that the slider is paired with a supported objective with a supported PH code.

### (3) GIF filter (green interference filter)

When performing phase contrast microscopy, mounting a field lens improves the contrast of the phase contrast image. See (8) Others in “4.2.1 Basic Configuration (for Bright-field Microscopy).”

### (4) Centering telescope

Attach the binoculars when adjusting the annular diaphragm position. See (8) Others in “4.2.1 Basic Configuration (for Bright-field Microscopy).”

## Attaching a Phase Contrast Slider

Insert a slider for phase contrast microscopy into the slot on the side of the condenser.

1. **Set the aperture diaphragm lever of the condenser to the NA 1.25 side.**
2. **Pull the dummy slider out of the slot on the right side of the condenser.**
3. **Remove the knob from the phase contrast slider.**  
The knob is in the form of a screw. Unscrew the knob to remove it.
4. **Insert the slider into the slot on the side of the condenser.**  
Turn the slider so that the centering screw faces the front of the microscope.  
The slider has protrusions to prevent incorrect insertion.
5. **Attach the knob to the slider you attached.**  
Attach the knob to the front of the slider.

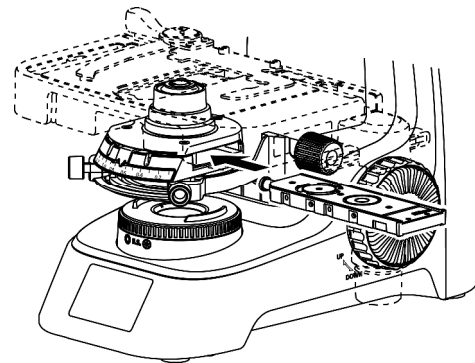

Insert the phase contrast slider.

### 4.2.3 Configuration for Simple Polarizing Microscopy

When performing simple polarizing microscopy, assemble the microscope in the basic configuration for bright-field microscopy, and then attach the following optical parts to the microscope:

#### (1) Simple polarization polarizer

Attach the simple polarization polarizer over the field lens.  
Adjust the polarization state by turning the polarizer.

#### (2) Simple polarization analyzer

Attach it to the dovetail at the eyepiece tube mount.  
Remove the eyepiece tube and attach the analyzer to the dovetail on the main body (vibration direction: fixed at the microscope front and back direction).

### Attaching the Simple Polarization Analyzer

Install the simple polarization analyzer on the round dovetail of the eyepiece tube mount.

- 1. Remove the eyepiece tube.**
- 2. Place the analyzer in the cavity in the eyepiece tube mount on the microscope main body.**  
Turn the analyzer so that the mark on the analyzer faces the screw on the rear of the eyepiece tube mount.  
The analyzer faces the microscope front and back direction. (This is also the light's vibration direction.)
- 3. Re-attach the eyepiece tube in its original position and fix it in place.**

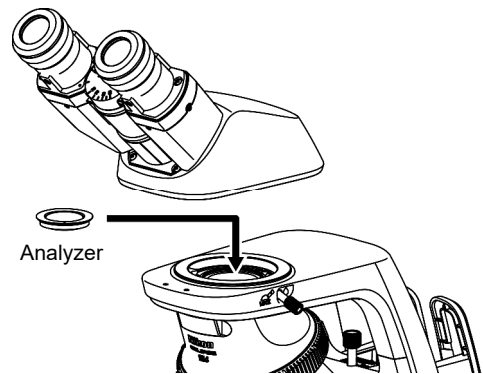

Attaching the analyzer

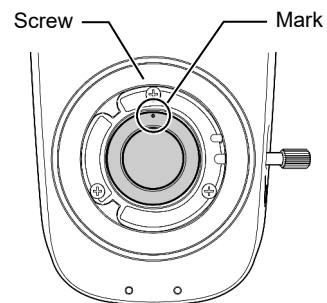

Orientation of the analyzer

### Attaching the Simple Polarization Polarizer

Install the simple polarization polarizer on top of the field lens.

- 1. Place the simple polarization polarizer in the upper part of the field lens unit on the microscope main body.**  
If you turn the polarizer unit so that the mark on the polarizer unit faces the front of the microscope, the polarizer's vibration direction becomes the microscope's right-left direction.
- 2. Tighten the fixing screw to fix the polarizer in place.**  
To fix the polarizer in an open Nicol state, remove the fixing screw, move it to another screw hole, and tighten the screw.

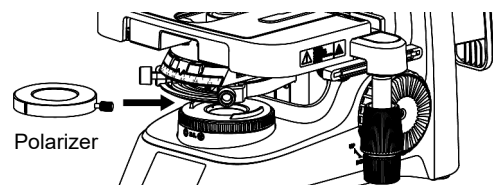

Attaching the polarizer

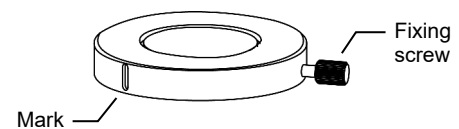

Mark and fixing screw for the polarizer

## 4.2.4 Configuration for Diascopic Fluorescence Microscopy

When performing diascopic fluorescence microscopy, assemble the microscope in the basic configuration for bright-field microscopy, and then attach the following optical parts to the microscope.

### (1) E2-F-FL Dia-FL Set GFP-B

The E2-F-FL Dia-FL Set GFP-B is composed of the following two parts:

- **EX filter slider**

The EX filter slider is installed in the slot on the side of the condenser. This slider is for switching the empty position for bright-field microscopy and the excitation filter for diascopic fluorescence.

- **BA filter slider**

The BA filter slider is installed in the slot on the front of the nosepiece. When you push this slider in all the way, the barrier filter is brought into the optical path. When you pull this slider out until the click position, the escape position for bright-field microscopy is brought into the optical path.

- **Shielding plate**

Attach the shielding plate to the tip of the arm using two fixing screws. This will prevent strong light including UV light from specimen through the condenser from flashing into your eyes.

### (2) Objective supporting diascopic fluorescence microscopy

The following three types of objectives can be used for diascopic fluorescence microscopy:

- CFI E Plan 4x
- CFI E Plan 10x
- CFI E Plan 40x

- ✓ **Restriction on using objectives**

60x and 100x objectives cannot be used for diascopic fluorescence microscopy.

## Attaching the EX Filter Slider

Attach the EX filter slider (excitation filter) to the microscope. The EX filter is inserted into the slot on the side of the condenser.

1. **Set the aperture diaphragm lever of the condenser to the NA 1.25 side.**
2. **Pull the dummy slider out of the slot on the right side of the condenser.**
3. **Insert the EX filter slider into the slot on the right side of the condenser.**

From the operating knob side, insert the slider so that the text "BF" and the abbreviated name of the microscopy method written on the slider are legible from the front of the microscope.

The slider has protrusions to prevent incorrect insertion, and cannot be inserted from the opposite side. To remove the slider, you must operate the knob.

4. **Confirm that the operating knob is on the left side of the condenser.**

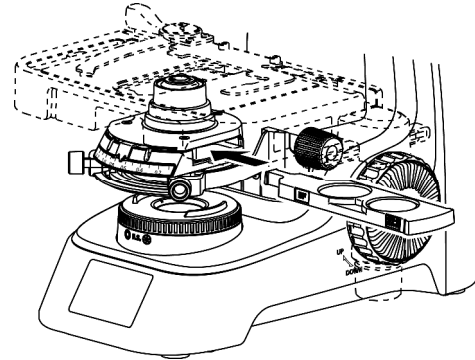

Attaching the EX filter slider

## Removing the EX Filter Slider

To remove the EX filter slider, perform the following procedure:

1. **Set the aperture diaphragm lever of the condenser to the NA 1.25 side.**
2. **While pressing the knob on the EX filter slider, push the slider in from the left side.**
3. **Pull out the EX filter slider from the right side.**

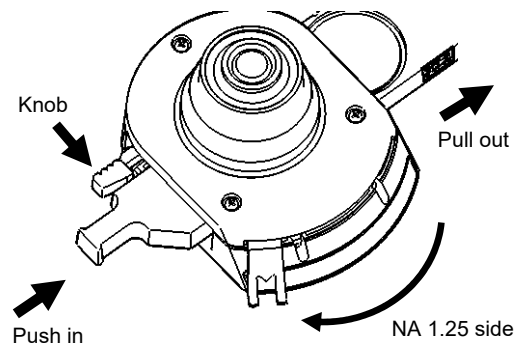

Removing the EX filter slider

## Attaching the BA Filter Slider

Attach the BA filter slider (barrier filter) to the microscope. The BA filter is inserted into the front slot of the nosepiece.

1. **Pull the dummy slider out of the front slot of the nosepiece.**
2. **Insert the BA filter slider into the front slot of the nosepiece, making sure the BA filter slider is facing the right direction.**

During insertion, make sure the tilt of the front of the filter matches the tilt of the nosepiece. The BA filter slider cannot be inserted facing the opposite direction.

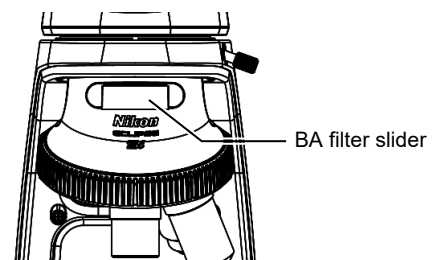

Attaching the BA filter slider

## Attaching the Shielding Plate

Attach the shielding plate to the arm end.

1. Turn the eyepiece tube 90°, and fix it as shown in the figure.

(See (2) Changing the direction of the eyepiece tube, removing and attaching the eyepiece tube in “4.2.1 Basic Configuration (for Bright-field Microscopy.)”)

2. Attach the shielding plate to the arm end as shown in the figure, and tighten two fixing screws using a tool supplied with the filter set.

3. Turn the eyepiece tube back to the observation position, and fix it.

✓ **Fixing screws and tool**

The fixing screws and tool are supplied with the Dia-FL Set GFP-B.

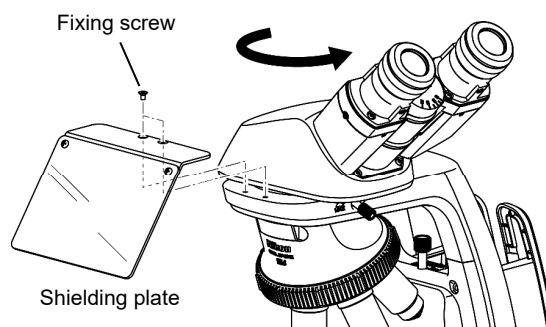

- (1) Turn the eyepiece tube 90°.
- (2) Attach the shielding plate using two screws.

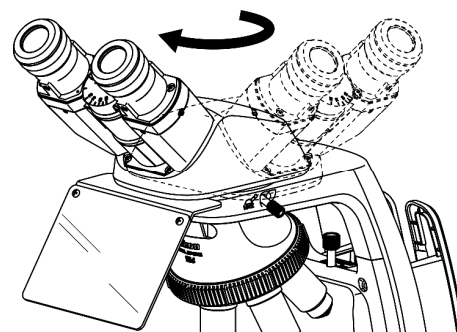

- (3) Turn the eyepiece tube back to the original position.

### Attaching the shielding plate

## 4.2.5 Configuration for Dark-Field Microscopy

When performing dark-field microscopy, assemble the microscope in the basic configuration for bright-field microscopy, and then attach the following optical parts to the microscope:

### (1) Slider for dark-field microscopy

### (2) Objective for dark-field microscopy

Objectives that can be used for dark-field microscopy are limited to the following:

- **For dark-field microscopy:** NA 0.65 or lower
- **For observation using a bright-field position:** NA 1.25 or lower

See (5) Installing the objective in “4.2.1 Basic Configuration (for Bright-field Microscopy).”

#### ✓ **Note on the bright-field position of the dark-field slider**

Objectives that can be used in the bright-field position of the dark-field slider have different conditions than for regular bright-field microscopy.

With objectives of NA 1.0 or higher, vignetting might occur in the periphery, causing the image to darken.

## Attaching the Slider for Dark-Field Microscopy

Insert the slider for dark-field microscopy into the slot on the side of the condenser.

1. **Set the aperture diaphragm lever of the condenser to the NA 1.25 side.**
2. **Pull the dummy slider out of the slot on the right side of the condenser.**
3. **Remove the knob from the slider for dark-field microscopy.**

The knob is in the form of a screw. Unscrew the knob to remove it.

4. **Insert the slider into the slot on the side of the condenser.**

Turn the slider so that the position mark faces the front of the microscope.

The slider has protrusions to prevent incorrect insertion.

5. **Attach the knob to the slider you attached.**

Attach the knob to the front of the slider.

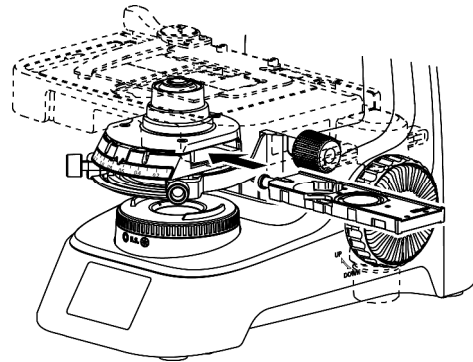

Inserting the slider for dark-field microscopy

## 4.3 Setting Up the Microscope

When you have finished attaching the optical parts to the microscope, you must register information about the objectives mounted on the microscope.

### (1) Turn off the microscope.

Disconnect the AC adapter and turn off the microscope.

### (2) Turn on the microscope while pressing the brightness control knob and illumination on/off button.

The SET UP screen appears.

#### ✓ Information on the objective

The address of the nosepiece that is in the optical path and information on the registered objective such as the objective name and magnification are displayed in the OBJECTIVE field.

Browse and select items on the SET UP screen by using the brightness control knob and illumination on/off button. To move the cursor, turn the brightness control knob. To select an item, press the illumination on/off button.

### (3) Input information about the objectives in each position of the nosepiece.

#### 1. Move the cursor (▶) to "OBJECTIVE" and press the illumination on/off button.

The cursor moves to the displayed name and magnification (for example, [E Plan / Mag: 4x]).

#### 2. Turn the nosepiece to bring the address to be registered into the optical path.

When you turn nosepiece, the registered name and magnification of the new objective is displayed. If you purchased the microscope as a set, the objectives included in the set have already been pre-registered.

#### 3. Turn the brightness control knob to specify the name and magnification of the objective.

Information on standard objectives is registered in the microscope.

If you are using a non-standard objective, select an item where only the magnification is displayed.

For positions where no objective is mounted, specify "None."

#### 4. Repeat steps 2 and 3 to register information about all the desired positions.

#### 5. Press the illumination on/off button.

The cursor moves to "ECO TIME."

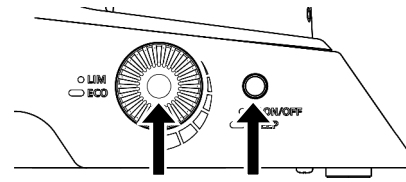

Turning on the microscope while pressing the brightness knob and illumination on/off button

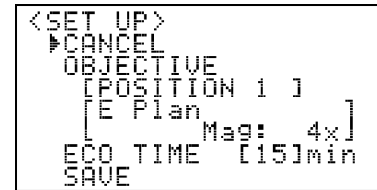

SET UP screen

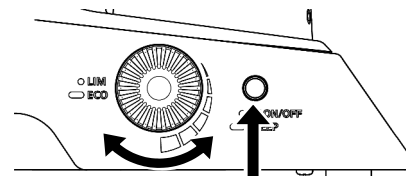

Browse items /values Select

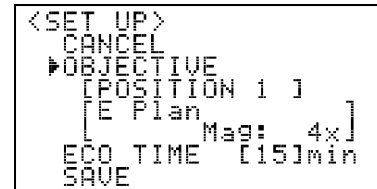

1. Select OBJECTIVE.

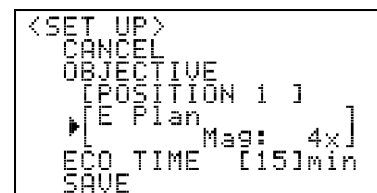

2. Turn the nosepiece to select the address.

3. Select the objective using the brightness control knob.

#### Objective setting values

|   | Objective type | Magnification value |    | Objective type | Magnification value |
|---|----------------|---------------------|----|----------------|---------------------|
| 1 | E Plan         | 4x                  | 10 |                | 1x                  |
| 2 | E Plan         | 10x                 | 11 |                | 2x                  |
| 3 | E Plan         | 40x                 | 12 |                | 4x                  |
| 4 | E Plan         | 60x                 | 13 |                | 10x                 |
| 5 | E Plan Oil     | 100x                | 14 |                | 20x                 |
| 6 | Achro Ph1      | 10x                 | 15 |                | 40x                 |
| 7 | Achro LWD Ph1  | 20x                 | 16 |                | 50x                 |
| 8 | Achro Ph2      | 40x                 | 17 |                | 60x                 |
| 9 | Achro Oil Oh3  | 100x                | 18 |                | 100x                |
|   |                |                     | 19 | None           | —                   |

**(4) Set how long ECO mode waits to enter sleep mode.**

1. **Move the cursor (▶) to “ECO TIME” and press the illumination on/off button.**  
The cursor moves to the displayed time period (“[15]min”).
2. **Specify how long to wait (in minutes) until entering sleep mode, and press the illumination on/off button (setting range: 1 to 60).**
3. **Press the illumination on/off button.**  
The cursor moves to “SAVE.”

**(5) To save the setting, select “SAVE” and press the illumination on/off button.**

The setting is saved, and the original screen appears.

If you select “CANCEL”, the changes are discarded and the original screen appears.

```

<SET UP>
CANCEL
OBJECTIVE
[POSITION 1 ]
[E Plan Mag: 4x]
▶ECO TIME [15]min
SAVE

```

Setting time before going to sleep mode

```

<SET UP>
CANCEL
OBJECTIVE
[POSITION 1 ]
[E Plan Mag: 4x]
ECO TIME [15]min
▶SAVE

```

Saving the setting



## 5

## Troubleshooting

Misuse of this product may adversely affect performance, even if this product is properly functional. If any of the following problems occurs, be sure to check the following table for possible causes before requesting service.

If you detect problems that are not listed below or the problem still persists after measures are taken, unplug the power cord of the device and contact your nearest Nikon representative.

## 5.1 Problems With the Microscope Image

### 5.1.1 Common Problems for Each Microscopy

#### Dirt or dust in the field of view

| Problems  | Check Items   | Reference |
|---|---|-----------|
| The specimen is dirty if dirt or dust moves when the specimen is moved on the stage.      | <input type="checkbox"/> Clean the specimen.            | 3.3.1     |
| Objective is dirty if dirt or dust disappears when the objective is switched.             | <input type="checkbox"/> Clean the objective.           | 6.1       |
| The eyepiece is dirty if dirt or dust does not move when the stage or objective is moved. | <input type="checkbox"/> Clean the eyepiece.            | 6.1       |
| Aperture diaphragm is closed too far.   | <input type="checkbox"/> Open properly. (→ Section 3.5) | 3.8       |

#### Poor image quality, low resolution, or contrast too low or too high

| Problems   | Check Items  | Reference |
|--|--|-----------|
| No coverglass is attached to the slide.                                | <input type="checkbox"/> Attach a coverglass 0.17 mm thick.  | —         |
| Coverglass is too thick or too thin.                                   | <input type="checkbox"/> Use a coverglass of the specified thickness (0.17 mm).  | —         |
| Slide is upside down.  | <input type="checkbox"/> Turn over the slide so that the cover glass faces up.   | 3.3.1     |
| Lenses or specimen are dirty or dusty.                                 | <input type="checkbox"/> Check dirty or dusty parts, and then clean them as appropriate by reference to the problems described in "Dirt or dust in the field of view." | —         |
| Aperture diaphragm is opened or closed too far.                        | <input type="checkbox"/> Close or open properly.   | 3.8       |
| Field diaphragm is opened or closed too far.                           | <input type="checkbox"/> Close or open properly.   | 3.9       |
| No immersion oil is applied to the tip of the oil-immersion objective. | <input type="checkbox"/> Apply Nikon immersion oil to the objective.   | 3.4.2     |
| Nikon immersion oil is not used for oil-immersion observation.         | <input type="checkbox"/> Apply Nikon immersion oil to the objective.   | 3.4.2     |
| Air bubbles in immersion oil.  | <input type="checkbox"/> Remove bubbles.   | 3.4.2     |
| Immersion oil adhering to the tip of the dry type objective.           | <input type="checkbox"/> Clean the lens.   | 6.1       |
| No coverglass is attached to the slide for observation.                | <input type="checkbox"/> Attach a coverglass.  | —         |

#### Image too bright

| Problems                               | Check Items   | Reference |
|--|---|-----------|
| Setting of the brightness control knob | <input type="checkbox"/> Adjust the brightness by rotating the brightness control knob. | 3.2.1     |

**Image not bright enough**

| Problems                               | Check Items   | Reference |
|--|---|-----------|
| Setting of the brightness control knob | <input type="checkbox"/> Adjust the brightness by rotating the brightness control knob. | 3.2.1     |
| Aperture diaphragm is closed too far.  | <input type="checkbox"/> Open properly.   | 3.8       |
| Field diaphragm is closed too far.     | <input type="checkbox"/> Open properly.   | 3.9       |

**Darkness at the periphery, no viewfield seen, or uneven viewfield brightness**

| Problems  | Check Items  | Reference    |
|---|--|--------------|
| Revolving nosepiece is not in click-stop position. (the objective is not centered in the optical path). | <input type="checkbox"/> Revolve to click-stop position (swing the objective correctly into the optical path). | 3.4.1        |
| Dirt or dust on the lens (condenser, objective, field lens, eyepiece), specimen                         | <input type="checkbox"/> Clean the lens.   | 6.1<br>3.3.1 |

**Image dark on one side (One side of the viewfield (up, down, right, or left) is not in focus.)**

| Problems   | Check Items   | Reference |
|--|---|-----------|
| Revolving nosepiece is not in click-stop position.                   | <input type="checkbox"/> Revolve to click-stop position.                  | 3.4.1     |
| Specimen rises from stage surface.                                   | <input type="checkbox"/> Stabilize it using the holder.                   | —         |
| The thickness of the sample (section) is not uniform and has a tilt. | <input type="checkbox"/> Prepare a sample (section) of uniform thickness. | —         |

**Image shifts during focus (Becomes asymmetrically defocused when moving the focal point.)**

| Problems   | Check Items   | Reference |
|--|---|-----------|
| Revolving nosepiece is not in click-stop position.                   | <input type="checkbox"/> Revolve to click-stop position.                  | 3.4.1     |
| Specimen rises from stage surface.                                   | <input type="checkbox"/> Stabilize it using the holder.                   | —         |
| The thickness of the sample (section) is not uniform and has a tilt. | <input type="checkbox"/> Prepare a sample (section) of uniform thickness. | —         |

**5.1.2 Problems in Phase Contrast Microscopy****Incomplete field of view or no field of view seen**

| Problems   | Check Items   | Reference    |
|--|---|--------------|
| The phase contrast slider is not at the click position (the annular diaphragm is not in the optical path). | <input type="checkbox"/> Move the slider until it clicks. | 2.2<br>4.2.2 |

**No phase contrast image seen**

| Problems                                   | Check Items  | Reference            |
|--|--|----------------------|
| You are not using a phase contrast slider. | <input type="checkbox"/> Mount a phase contrast slider and bring the appropriate position into the optical path. | 2.2<br>4.2.2         |
| You are not using a Ph objective.          | <input type="checkbox"/> Bring a Ph objective containing a phase plate into the optical path.                    | 2.2<br>3.11<br>4.2.2 |

**Weak contrast in phase contrast image**

| Problems  | Check Items  | Reference     |
|---|--|---------------|
| The Ph annular diaphragm of the phase contrast slider and the Ph code of the objective are incompatible.                  | <input type="checkbox"/> Bring a Ph annular diaphragm that has the same code as the objective's Ph code into the optical path. | 2.2<br>3.10.1 |
| The Ph annular diaphragm of the phase contrast slider and the objective's phase ring image are not at matching positions. | <input type="checkbox"/> Adjust the position of the annular diaphragm.   | 2.2<br>3.10.1 |
| The specimen's phase difference is too big.   | <input type="checkbox"/> Make a new specimen with a different mounting agent or specimen thickness.                            | 3.10.1        |
| The specimen's phase difference and the Ph objective type are incompatible.   | <input type="checkbox"/> Use an appropriate Ph objective for the specimen.   | 3.10.1        |
| You are not using a GIF filter.   | <input type="checkbox"/> Mount a GIF filter on the field lens.   | 2.2<br>3.10.1 |

**5.1.3 Problems in Simple Polarizing Microscopy****Incomplete field of view or no field of view seen**

| Problems                                  | Check Items  | Reference    |
|---|--|--------------|
| The polarizer has been mounted at a tilt. | <input type="checkbox"/> Install the polarizer so that it lies flat. | 2.3<br>4.2.3 |

**5.1.4 Problems in Diascopic Fluorescence Microscopy****Incomplete field of view or no field of view seen**

| Problems   | Check Items   | Reference    |
|--|---|--------------|
| The EX filter slider is not at the click position. | <input type="checkbox"/> Move the slider until it clicks.   | 2.4<br>4.2.4 |
| The BA filter slider is not at the click position. | <input type="checkbox"/> Push in the slider all the way.<br><input type="checkbox"/> Move the slider until it clicks. | 2.4<br>4.2.4 |

**No fluorescence image seen**

| Problems  | Check Items  | Reference    |
|---|--|--------------|
| The excitation filter is not in the optical path. | <input type="checkbox"/> Push in the EX filter slider from the right side, bringing the GFP position into the optical path.  | 2.4<br>4.2.4 |
| The barrier filter is not in the optical path.    | <input type="checkbox"/> Push in the BA filter slider all the way, bringing the barrier filter into the optical path.  | 2.4<br>4.2.4 |
| Diascopic illumination is not bright enough.      | <input type="checkbox"/> Adjust the illumination by turning the brightness control knob close to the maximum position.<br><input type="checkbox"/> Widen the aperture diaphragm. | 3.2.1<br>3.8 |

**Fluorescence image is dark (even though the light source is turned on).**

| Problems  | Check Items  | Reference |
|---|--|-----------|
| The diascope illumination is not bright enough. | <input type="checkbox"/> Adjust the illumination by turning the brightness control knob close to the maximum position. | 3.2.1     |
| The room is too bright.                         | <input type="checkbox"/> Dim the ambient light.  | 3.10.3    |

**Weak contrast in fluorescence image**

| Problems                                    | Check Items   | Reference |
|---|---|-----------|
| The objective or cover glass is dirty.      | <input type="checkbox"/> Clean the lens.  | 3.3.1     |
| The immersion oil is emitting fluorescence. | <input type="checkbox"/> Use a low-fluorescence oil (Nikon immersion oil) specified by Nikon. | 3.4.2     |
| The slide glass is emitting fluorescence.   | <input type="checkbox"/> Use a non-fluorescent glass slide.                                   | —         |

**5.1.5 Problems in Dark-field Microscopy****Incomplete field of view or no field of view seen**

| Problems   | Check Items  | Reference    |
|--|--|--------------|
| The dark-field slider is not at the click position (the annular diaphragm is not in the optical path). | <input type="checkbox"/> Move the slider until it clicks.                      | 2.5<br>4.2.5 |
| The objective's NA is not in this microscope's supported range for dark-field microscopy.              | <input type="checkbox"/> Bring the dark-field objective into the optical path. | 3.10.4       |

**No dark-field image seen**

| Problems  | Check Items  | Reference    |
|---|--|--------------|
| You are not using a dark-field slider.  | <input type="checkbox"/> Mount a phase contrast slider and bring the appropriate position into the optical path. | 2.5<br>4.2.5 |
| The objective's NA is not in this microscope's supported range for dark-field microscopy. | <input type="checkbox"/> Bring the dark-field objective into the optical path.                                   | 3.10.4       |

## 5.2 Problems in Operation

### Image cannot be focused with high magnification objectives.

| Problems                 | Check Items   | Reference |
|--------------------------|---|-----------|
| Slide is upside down.    | <input type="checkbox"/> Turn over the slide so that the cover glass faces up.  | 3.3.1     |
| Coverglass is too thick. | <input type="checkbox"/> Use a coverglass of the specified thickness (0.17 mm). | —         |

### High magnification objective contacts slide when changed over from low magnification.

| Problems                             | Check Items   | Reference |
|--------------------------------------|---|-----------|
| Slide is upside down.                | <input type="checkbox"/> Turn over the slide so that the cover glass faces up.  | 3.3.1     |
| Coverglass is too thick.             | <input type="checkbox"/> Use a coverglass of the specified thickness (0.17 mm). | —         |
| Diopter is not adjusted correctly.   | <input type="checkbox"/> Adjust.  | 3.6.1     |
| Objective is not attached correctly. | <input type="checkbox"/> Screw the objective all the way in.                    | 4.2       |

### Difference in focal point too large when switching from one objective to another

| Problems                             | Check Items  | Reference |
|--------------------------------------|--|-----------|
| Diopter is not adjusted correctly.   | <input type="checkbox"/> Adjust.                             | 3.6.1     |
| Objective is not attached correctly. | <input type="checkbox"/> Screw the objective all the way in. | 4.2       |

### Image cannot be in focus.

| Problems  | Check Items  | Reference |
|---|--|-----------|
| The stage vertical movement stopper is lower than the focal position. | <input type="checkbox"/> Turn the stage stopper counterclockwise until it reaches the limit. | 3.5.3     |

### Binocular images are not integrated.

| Problems                           | Check Items   | Reference |
|------------------------------------|---|-----------|
| Diopter is not adjusted correctly. | <input type="checkbox"/> Interpupillary distance is not adjusted correctly. | 3.6.2     |
| Diopter is not adjusted correctly. | <input type="checkbox"/> Adjust.  | 3.6.1     |

### Excessive eye fatigue during observation

| Problems                               | Check Items   | Reference |
|--|---|-----------|
| Diopter is not adjusted correctly.     | <input type="checkbox"/> Adjust.  | 3.6.2     |
| Diopter is not adjusted correctly.     | <input type="checkbox"/> Adjust.  | 3.6.1     |
| Inadequate brightness or illumination. | <input type="checkbox"/> Adjust brightness using the brightness control knob. | 3.2.1     |

## 5.3 Electrical

### Illumination does not turn on when the illumination on/off button is turned on.

| Problems   | Check Items   | Reference |
|--|---|-----------|
| The AC adapter is not connected to the microscope main body. | <input type="checkbox"/> Insert the DC plug of the AC adapter into the DC input connector.              | 3.1.1     |
| No electrical power.   | <input type="checkbox"/> Insert the power cord connected with the AC adapter into an electrical outlet. | 3.1.1     |

### Flickering or unstable illumination brightness

| Problems   | Check Items                                 | Reference |
|--|---|-----------|
| The AC adapter or power cord is not correctly connected. | <input type="checkbox"/> Connect correctly. | 3.1.1     |

### Brightness of the illumination changes when objectives are switched.

| Problems  | Check Items  | Reference |
|---|--|-----------|
| The light intensity management function is turned on. | <input type="checkbox"/> To prevent the brightness from changing automatically, turn off light intensity management. | 3.2.2     |

### Illumination turns off when left idle (no operations are performed) for a certain period.

| Problems        | Check Items   | Reference |
|-----------------|---|-----------|
| ECO mode is on. | <input type="checkbox"/> Operate controls such as the illumination on/off button, the brightness control knob, and the nosepiece.<br><input type="checkbox"/> To prevent illumination from turning off automatically, turn off ECO mode.<br><input type="checkbox"/> In the settings, change how long to wait before entering sleep mode. | 3.1.2     |

### Objective information not shown on the display, or incorrect information displayed

| Problems                                     | Check Items   | Reference |
|--|---|-----------|
| Information on the objective is not set.     | <input type="checkbox"/> Set the information in the SETUP screen. | 4.3       |
| Information on the objective is not updated. | <input type="checkbox"/> Set the information in the SETUP screen. | 4.3       |

# 6

## Care and Maintenance

### 6.1 Cleaning the Lenses

- Dust is best removed using a soft brush or gauze.
- More persistent dirt, such as fingerprints, grease and oil, may be removed with clean lens tissue (or soft cotton, gauze) lightly moistened with absolute alcohol (ethyl alcohol or methyl alcohol).
- To clean immersion oil off the oil-immersion type objective, use lens tissue, soft cotton or gauze lightly moistened with petroleum benzene. If petroleum benzene is not available, use methyl alcohol. In this case, you need to wipe 3 to 4 times because the detergency of the methyl alcohol is somewhat weak.
- Cleaning the condenser  
If the condenser was used with oil immersion, remove the condenser from the microscope and clean the lens as necessary.  
Also ensure that the condenser is removed from the microscope and cleaned as necessary during regular cleaning operations.
- Absolute alcohol and petroleum benzene are quite inflammable. Take great care when handling them and when turning the power switch on and off. Be very careful with fire.
- When using absolute alcohol and petroleum benzene, follow the instructions provided by the manufacturer.

### 6.2 Cleaning the Microscope

- We recommend that you use a silicon cloth to clean the microscope.
- For persistent dirt, dampen a piece of gauze with neutral detergent and wipe lightly.
- Do not use organic solvent (alcohol, ether, or thinner). Doing so may result in discoloration of the coating and plastic parts or removal of the printed text.

### 6.3 Disinfecting the Microscope

- We recommend that you use 70% medical alcohol for normal disinfection of the microscope.
- In case of spillage of a sample to the microscope, determine whether the sample is hazardous. If the sample is hazardous, follow the standard procedure of your laboratory.
- Using organic solvent may result in discoloration of the plastic parts.

### 6.4 Storing the Microscope

- When the microscope is not in use, put a vinyl dust cover over the product to protect it from dust, and store it in a dry place where mold is not likely to form.
- Before covering the microscope with the vinyl cover, unplug the power cord.
- We especially recommend that the objectives and eyepieces be kept in a container (such as a desiccator) with desiccant in it.

### 6.5 Periodical Inspections (Charged)

- To maintain the performance of the microscope, periodical inspections and maintenance are recommended.
- For details, contact your nearest Nikon representative.

# 7

## Specifications

### 7.1 Microscopy (Principles)

Use objectives and eyepieces of the microscope to magnify minute cells and tissue optically, and manipulate levers and knobs of the microscope unit to adjust the focus or move the observation point. Then observe or take photographs of the sample fixed on the slide.

#### **Intended use of the product (for medical care)**

This microscope is intended for use in microscopic experiment and diagnostics of cells and tissues at hospitals or by doctors in private practice in the field of pathology, anatomy, and cytology.

The microscopy with diasopic/episcopic illuminations is used to observe a sample fixed on the slide (cells and tissue) as the specimen.

The product is classified as an in-vitro diagnostic medical device. **IVD**

This product is not intended for use for measurement.

The scale on the focus knob and stage is an indicator to reproduce the position and does not guarantee the value of the thickness or length of a sample measured using this scale.

#### **Intended user**

It is intended for the medical professional and those who work on experimentations in the field of pathology and cytology.



## 7.2 Performance Properties

|                                     |   |
|-------------------------------------|---|
| <b>Model Name</b>                   | ECLIPSE Si RS Main Body   |
| <b>Optical System</b>               | CFI60 (Infinity-corrected CF optical system)<br>Field Number: It depends on the combination.<br>When using Si eyepiece tubes and other optional products supporting a field number of 20: FN 20<br>When using Ci eyepiece tubes and other optional products supporting a field number of 22: FN 22              |
| <b>Eyepieces</b>                    | 10X, FN 20  |
| <b>Condenser</b>                    | Supports phase contrast microscopy, contains an aperture diaphragm, and comes with a slot<br>Aperture diaphragm: Ø2 mm to Ø28 mm<br>Centering range: Ø4 mm or more<br>Vertical stroke: 2 mm upward and 13 mm downward<br>Attachment and removal mechanism: One-touch attachment and removal using a leaf spring |
| <b>Illumination device</b>          | Koehler illumination device using a white LED, containing a fly-eye lens<br>Field diaphragm: Ø1.5 mm to Ø18 mm<br>Field lens: Allows two ø45-mm filters (of thickness 2.5 mm or less) to be attached  |
| <b>Focusing Mechanism</b>           | Manual single-axis coarse/fine movement handle (double-sided coarse/fine movement)<br>Fine focus knob graduation: 2 µm/graduation<br>Fine focus knob travel: 0.2 mm/rotation<br>Coarse focus knob travel: 37.7 mm/rotation<br>Vertical movable range: 2 mm upward and 13 mm downward (from the focal plane)     |
| <b>Stage</b>                        | Height of stage upper surface: 135 mm (above the table surface)<br>Stroke: Right and left axis: 76 mm<br>Front and back axis: 52 mm<br>0.1 mm graduation readable using Vernier   |
| <b>Specimen holder</b>              | Supported slide glass thickness: 0.8 mm or more<br>Fastening method: One sided claw grip type<br>Allows up to two 76 mm x 26 mm glass slides to be attached   |
| <b>Revolving Nosepiece</b>          | 5-hole fixed type, state-detecting type<br>Tilt angle: 22.5°<br>Objective attachment screw: M25   |
| <b>Supported microscopy methods</b> | Bright-field, phase-contrast, simple-polarizing, diascope fluorescence, dark-field  |

## 7.3 Physical Properties

|   |  |  |
|---|--|--|
| <b>Model Name</b>                               | ECLIPSE Si RS Main Body  |  |
| <b>External dimensions and mass (reference)</b> | Main body (only):<br>External dimensions: 236 (W) x 284 (H) x 280 (D) mm<br>Mass (reference): Approximately 5.3 kg<br>Set containing binocular eyepiece tube:<br>External dimensions: 236 (W) x 401.5 (H) x 280 (D) mm (excluding protrusion)<br>Mass (reference): Approximately 6.0 kg  |  |
| <b>Electrical shock protection class</b>        | Class III  |  |
| <b>Environmental conditions</b>                 | Operation:                      Temperature: 0 to +40°C<br>Humidity: 60% RH Max. (at +40°C) (no condensation)<br>Storage and Transport:        Temperature: -20 to +60°C<br>Humidity: 90% RH Max. (no condensation)<br>Altitude:                         2,000m Max.<br>Pollution:                        Degree 2<br>Overvoltage category:         Category II<br>Indoor use only |  |

## 7.4 AC adapter

|  |  |  |
|--|--|--|
| <b>Names</b>   | AC adapter   |  |
| <b>Manufacturer's name or trade mark, commercial registration number and address</b> | Adapter Technology Co., Ltd.<br>6F-9 No. 258 Liancheng Rd Zhonghe District New Taipei 235 TAIWAN   |  |
| <b>Model identifier</b>  | ATS018T-P050   |  |
| <b>Input voltage, input current</b>  | Universal 100-240 VAC $\pm 10\%$ , single phase, 0.48A Max.  |  |
| <b>Input AC frequency</b>  | 50-60 Hz   |  |
| <b>Output voltage</b>  | 5.0 VDC  |  |
| <b>Output current</b>  | 3.0 A  |  |
| <b>Output power</b>  | 15.0 W   |  |
| <b>Average active efficiency</b>   | 82.6 %   |  |
| <b>Efficiency at low load (10%)</b>  | 79.6 %   |  |
| <b>No-load power consumption</b>   | >0.04 W  |  |
| <b>External dimensions</b>   | 50 (W) x 33 (H) x 100 (D) mm   |  |
| <b>Mass (reference)</b>  | Approx. 170 g (without the power cord)   |  |
| <b>Electrical shock protection class</b>   | Class I  |  |
| <b>Environmental conditions</b>  | Operation:                      Temperature: 0 to +40°C<br>Humidity: 20 to 80% RH (no condensation)<br>Storage and Transport:        Temperature: -20 to +80°C<br>Humidity: 10 to 90% RH (no condensation)<br>Altitude:                         2,000 m Max.<br>Pollution:                        Degree 2<br>Overvoltage category:         Category II<br>Indoor use only |  |
| <b>Safety standards</b>  | CE marking, GS mark, C-UL-US Listed, PSE mark  |  |

## 7.5 Power Cord

|  |  |
|--|--|
| <b>When used in Japan:</b>                             | PSE approved detachable power cord set<br>3 conductor grounding Type VCTF 3x0.75mm <sup>2</sup> , 3m long maximum, rated at 125 VAC minimum)           |
| <b>When used in a 100-120 V region, outside Japan:</b> | UL listed detachable power cord set<br>3 conductor grounding Type SVT, NO.18 AWG, 3m long maximum, rated at 125 VAC minimum)                           |
| <b>When used in a 220-240 V region:</b>                | EU/EN standard approved detachable power cord set<br>3 conductor grounding Type H05VV-F 1 mm <sup>2</sup> , 3m long maximum, rated at 250 VAC minimum) |

## 7.6 Safety standards

|                         |   |
|-------------------------|---|
| <b>Safety standards</b> | <ul style="list-style-type: none"> <li>• C-UL-US Listed</li> <li>• FCC Part 15 Subpart B Class A<br/>           Note: This equipment has been tested and found to comply with the limits for a Class A digital device, pursuant to Part 15 of the FCC Rules. These limits are designed to provide reasonable protection against harmful interference when the equipment is operated in a commercial environment. This equipment generates, uses, and can radiate radio frequency energy and, if not installed and used in accordance with the instruction manual, may cause harmful interference to radio communications. Operation of this equipment in a residential area is likely to cause harmful interference in which case the user will be required to correct the interference at his own expense.</li> <li>• CAN ICES-003(A) / NMB-003(A)</li> <li>• Australian EMI (AS/NZS CISPR11)</li> </ul> <p>CE Marking</p> <ul style="list-style-type: none"> <li>• IVD Directive<br/>           This equipment complies with the emission and immunity requirements of IEC/EN 61326-2-6.</li> <li>• Low Voltage Directive</li> <li>• EMC Directive</li> </ul> |
|-------------------------|---|



## 7.7 External dimensions (unit: mm)

### Binocular eyepiece tube set

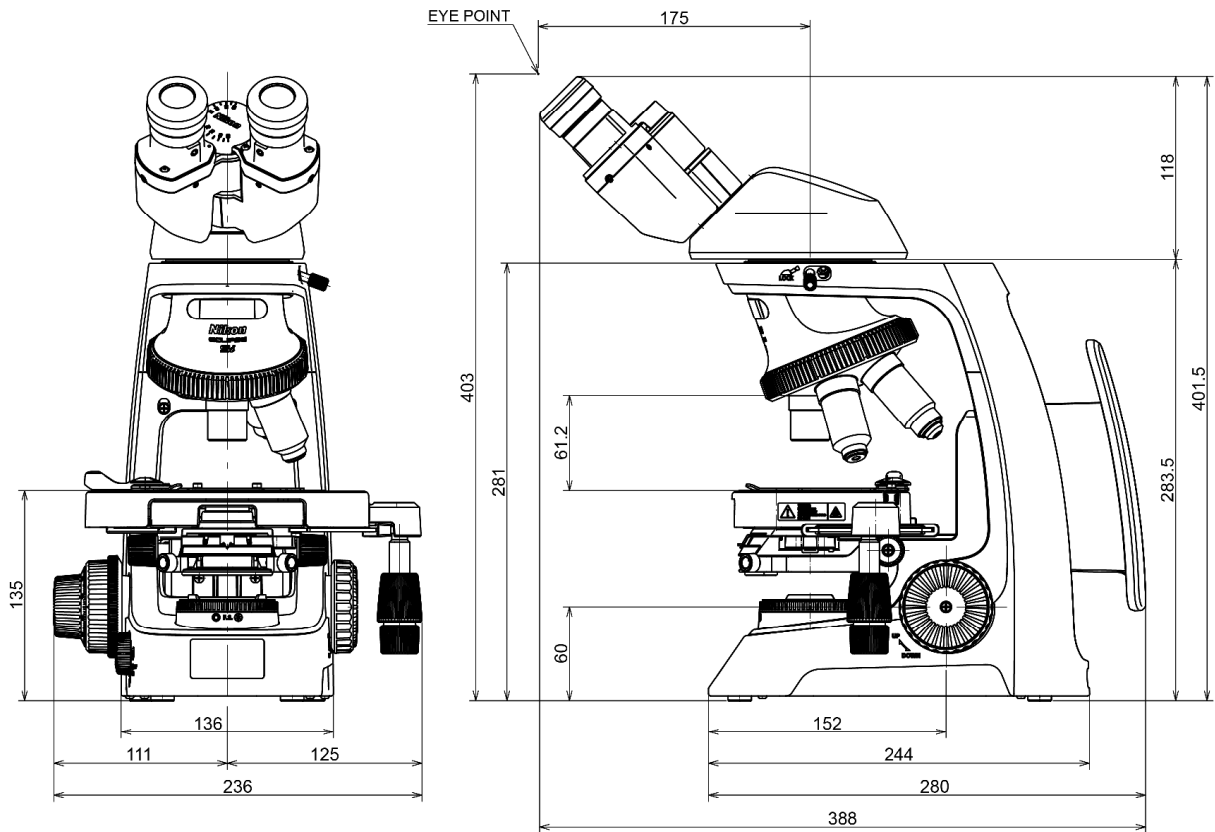

### Trinocular eyepiece tube set

