



EC CERTIFICATE

Production Quality Assurance

Certificate No.: 1000448399-PA-NA-NOR

Project No.: PRJC-519733-2015-MSL-NOR_MDD Valid Until: 27 May 2024

This is to certify that the quality system of:

Arctiko

Oddesundvej 39,
Esbjerg N, 6715
Denmark

For production and final product inspection/testing of:

Blood bank refrigerators

Has been assessed with respect to:

The conformity assessment procedure described in Annex V of Council Directive 93/42/EEC on Medical Devices, as amended

and found to comply

Further details of the product(s) and conditions for certification are given overleaf.

Place and date:
Høvik, 20 May 2021

For the issuing office:
**Notified Body 2460
DNV Product Assurance AS**



Mariann Jeremiassen
Principal Assessor

Notice: The Certificate is subject to terms and conditions as set out in the Certification Agreement. Failure to comply may render this Certificate invalid.

NOTIFIED BODY 2460: DNV Product Assurance AS, Veritasveien 3, 1363 Høvik, Norway, Tel +47 67 57 88 00, www.dnv.com

ICP-4-5-11-MDD-f1, rev.0



Certificate No.: 10000448399-PA-NA-NOR
Place and date: Høvik, 20 May 2021

Jurisdiction

Application of Council Directive 93/42/EEC of 14 June 1993, adopted as “Forskrift om Medisinsk Utstyr” by the Norwegian Ministry of Health and Care Services.

Certificate history:

Revision	Description	Issue Date
0.0	Original Certificate	2021-05-20

Products covered by this Certificate:

Product Description	Product Name	Class
Blood bank refrigerators	BBR100, BBR300, BBR500, BBR700, BR1400, BBR100-D, BBR300-D, BBR500-D, BBR700-D, BBR1400-D	Ila

The complete list of devices is filed with the Notified Body

Sites covered by this certificate

Site Name	Address
Arctiko	Oddesundvej 39, Esbjerg N, 6715 Denmark

Terms and conditions

The certificate is subject to the following terms and conditions:

- Any producer (see 2001/95/EC for a precise definition) is liable for damage caused by a defect in his product(s), in accordance with directive 85/374/EEC, as amended, concerning liability of defective products.
- The certificate is only valid for the products and/or manufacturing premises listed above.
- The Manufacturer shall fulfil the obligations arising out of the quality system as approved and uphold it so that it remains adequate and efficient.
- The Manufacturer shall inform the Notified Body of any intended updating of the quality system and the Notified Body will assess the changes and decide if the certificate remains valid.
- Periodical audits will be held, in order to verify that the Manufacturer maintains and applies the quality system. The Notified Body reserves the right, on a spot basis or based on suspicion, to pay unannounced visits.

The following may render this Certificate invalid:

- Changes in the quality system affecting production.
- Periodical audits not held within the allowed time window.

Conformity declaration and marking of product

When meeting with the terms and conditions above, the producer may draw up an EC declaration of conformity and legally affix the CE mark followed by the Notified Body identification number.

End of Certificate

MANAGEMENT SYSTEM CERTIFICATE

Certificate No.:
10000320341-PA-NA-NOR

Project No.:
PRJC-519733-2015-MSL-NOR

Initial Certification Date:
05 December 2019

Valid Until:
04 December 2022

This is to certify that the management system of:

Arctiko A/S

Oddesundvej 39, 6715 Esbjerg N, Denmark

Complies with the requirements of:

ISO 13485:2016/NS-EN ISO 13485:2016

The Certificate is valid for the following scope:

DESIGN, DEVELOPMENT, MANUFACTURING, SALES AND SERVICES OF REFRIGERATORS AND FREEZERS CLASSIFIED AS MEDICAL DEVICES.

Place and date:
Høvik, 05 December 2019



For:
DNV GL PRESAFE AS

Eugenie Winger Husebye
Eugenie Winger Husebye

The certificate is digitally verified by blockchain technology. For more info, see www.dnvgl.com/assurance/certificates-in-the-blockchain.html





LFF 270

SMART FRIDGE AND FREEZER IN ONE CABINET, MAKES IT A PERFECT SOLUTION FOR LABORATORIES WITH LIMITED SPACE DUE TO THE SMALL FOOTPRINT.

With air forced cooling and automatic defrost which will save time to focus on what's most important and store the samples most reliable.



AVAILABLE IN
ATEX



AIR FORCED
COOLING



FILTERLESS
CONSTRUCTION

INDEPENDENT & LESS FOOTPRINT

The LFF comes with two controllers allowing you to set and operate them as two independent units. With separate locks and passwords, it provides the ability to restrict access to storage and settings, in case the unit have multiple users. The unit is in effect of two fully independent units each with its own compressor, cooling circuit and controller – allowing to turn off one of the compartments in case that they are not in use for some time.

STAINLESS STEEL & AUTOMATIC DEFROST

The unit is available with stainless steel AISI 304 Exterior, so that the interior and exterior is made entirely of stainless steel, providing a stronger more resistant unit.

With Arctiko's automatic defrost system it's not required to remove samples prior to defrosting, saving you valuable time to focus on what matter the most and at the same time stores the samples safely.

EXCEPTIONAL COOLING

Arctiko has combined the high quality cooling performance created by air-forced cooling and automatic defrosting.

The results meet the more stringent requirements for lower power consumption, more precise cooling uniformity, need for temperature and alarm surveillance, documentation and validation, making the LFF 270 the perfect solution for biomedical storage.

MAIN DIMENSION FOR LFF 270

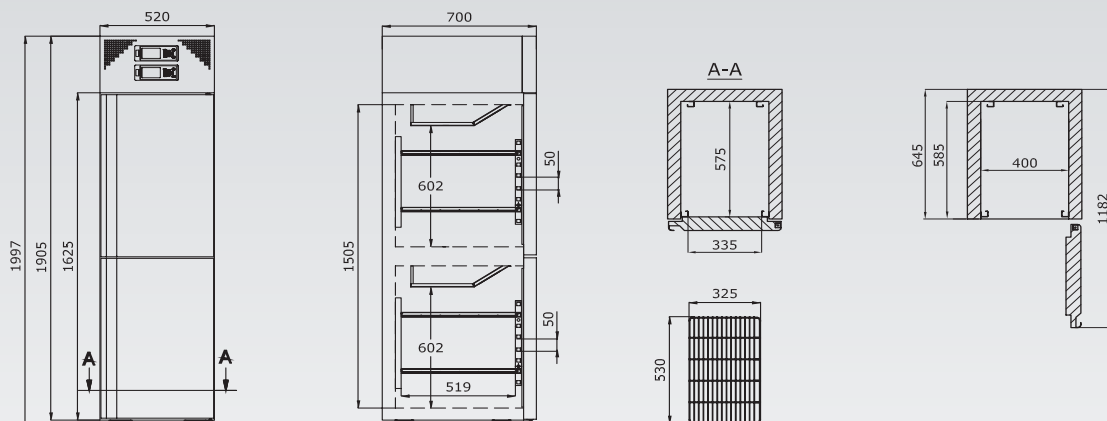

MAIN SPECIFICATIONS

Item code	DAI 0235 / DAI 0236
Temperature range (°C)	+1 / +10 -10 / -30
Max. ambient temperature (°C)	32
Capacity (L)	161 / 161
Exterior dimensions WxDxH (mm)	520x700x1997
Interior dimensions WxDxH (mm)	2x(400x575x700)
Weight (KG)	120
Insulation (mm)	60
Cooling technology	air forced
Controller model / probe type	G214 / PT1000

POWER

Power supply (V)	230*
Frequency (Hz)	50/60
Power consumption (kWh/24H)	11,4
AMP (A)	5,8
Power (Watt)	728
Horse power (HP)	1/10 + 1/8

ALARM FUNCTIONS

Alarm display as text - not codes	yes
Visual / acoustic alarm	yes / yes
Power failure alarm	yes
Adjustable high / low temperature alarm	yes / yes
Open door alarm	yes
Probe failure alarm	yes
Low battery alarm	yes
Compressor failure alarm	no
Battery backup for alarms (approx. hrs.)	72

DATA LOGGING & EXTERNAL CONNECTION

Voltage free contact for remote alarm (e.g. GSM alarm module)	yes
Electronic data logger	yes
RS 485 port	yes
USB port for software update & data download	yes
Temperature chart recorder	optional

DISPLAY FEATURES

Display type	4,3" with touch buttons
Number of optional reference probes	2
Password protection for turning unit on / off	yes
Temperature graph on display	yes

OTHER FEATURES

Automatic defrost	yes
Antifreeze function	no
Vacuum release port	no
Access port for external probe etc. (int. diameter mm)	optional
Light	no
Lock with key	yes
Castors (total pcs) / castors with brake (pcs)	4 / 2
Fixed feet (pcs) / levelling feet (pcs)	no
Sub lids or inner doors (pcs)	no
Reversible door(s)	yes
Fixed shelves (pcs) / adjustable shelves (pcs)	0 / 4
Max. no. of shelves (pcs) / recommended max. no. of shelves (pcs)	16 / 8
Max. load per shelf (kg)	30
Adjustable drawers (pcs)	optional
Max. no. of adjustable drawers (pcs)	6
Max. load per adjustable drawer (kg)	30

REFRIGERATION & CABINET

Number of compressors	2
Refrigerant	R290
Interior cabinet material	stainless steel
Exterior cabinet material	painted steel / stainless steel
Colour (exterior cabinet)	white / stainless steel
Foam type	polyurethane
VIP vacuum insulated panels	no

SHIPPING

Shipping weight (KG)	175
Shipping dimensions WxDxH (cm)	83x67x220
Shipping volume (m ³)	1,22

*110V/60Hz available as option

OPTIONAL ACCESSORIES

GSM alarm module
Temperature chart recorder
Shelves (perforated, wire stainless steel, plastic coated)
Drawers (stainless steel)
Modbus adapter
Voltage stabilizer
Voltage converters
LED light

Arctiko A/S

Oddesundvej 39 · DK-6715 Esbjerg N · Phone: +45 7020 0328
info@arctiko.com ■ arctiko.com



Intertek

Intertek