

# SWS-6000 series Hemodialysis Equipment

# Operation Manual

Software Version: V6.1.xxx

Edition: V1.10

April 2021



**SWS**  
MEDICAL



# Important Notes

## Principle

- According to the copyright law, reproducing this book in whole or in part without permission is prohibited.
- This book is to tell the operator how to operate correctly and safely, but not to explain how to treat the patients.
- Before operating the machine, the operator must have been read this operating instruction and starts operate after understanding the characteristics and usage methods of the machine.
- The correct installation, use and maintenance can reduce the faults of the equipment and ensure the best performance of the machine.
- This manual should be kept and placed in a user accessible place.
- The contents in this book may be changed due to the product without prior notice.
- Once there is an unknown place about the content of the book, please contact our customer service department.

## Guarantee

- The warranty period about the body and the attachments of this equipment is from the date of purchase within 1 year.
- In the warranty period, failure or damage associated with the following matters are not guaranteed.
  - The malfunction of installation, relocation, maintenance and repair by the person which is not our company' s or not designated by our company.
  - The malfunction by using other company' s products.
  - The malfunction belongs to user' s responsibility such as transformation, turnover, operational errors, and misuse and so on.
  - The malfunction by maintenance and repair with other company' s maintenance components.
  - The malfunction by fire, nature disasters (earthquake, flood, etc.).
  - The malfunction by nonobservance of notes and operational methods in this book.
  - The malfunction by using equipment without maintenance tests.

## Exemption

- The company does not undertake any responsibility for the fault caused by medical problems.
- The company does not undertake any responsibility for the fault caused in excess of this manual.

# Safety precautions

## ➤ About instruction manual

- Please read the instruction manual before using. In order to exert the safe and reliable performance of the machine, please operate and maintain according to this book. Understand the requirements correctly before using, and disoperation may cause danger or damage the machine.
- The operation methods and safety precautions of this manual are only used in the specified range. If operate this equipment with other manual, the safe responsibility belongs to operator.
- The operator should master the methods of quick turn off the machine. In order to ensure patients' safety, it is prohibited that operator operates the equipment without proper guidance and training.
- When the equipment is stopped during treatment by equipment failure or some alarms, operator should master the treatment methods according to the manual.
- Operation and maintenance should according to the methods specified by the manufacturer, or else there may be some danger. If not, the manufacturer is not responsible for the safety of patients. Please do let trained operators operate according to the methods specified by the manufacturer.

## ➤ Installation calibration setting

- Before install this machine, please read and understand this manual. The equipment must be installed by qualified person.
- After open the package, please check the lists including the machine, accessories and random files.
- Dismantle strictly in accordance with the instructions. It is prohibited that dismantle, repair and remold outside the specification.
- LCD screen and mask should avoid strong impact. While cleaning, do not impact LCD, touch screen and mask. And avoid collision.
- The equipment should be stored in a dry room.
- Please do not put equipment in these places that may be influenced by air pressure, temperature, humidity, ventilation, sunlight, dust, salt, sour ingredients and chemicals.
- The equipment must be installed well. Avoid falling, vibrating, and impact (include carrying and delivery).
- Note the frequency of the power supply, the state (polarity), the voltage and the current permissible value (or power consumption).
- Confirm whether the water quality is compliance with the relevant standards.

- Ensure grounding well.

➤ **Notice before use**

- The socket must be properly grounded and installed well. The grounding resistance should be less than  $1\Omega$ . In addition to repair, please do not touch the circuit board, wiring and terminal.
- Check switch, polarity and parameter to ensure equipment operates well.
- Ensure all wires connection properly.
- One equipment for several patients may lead to misdiagnosis or dangerous, so it should be given full attention.
- The space between pump head of blood pump and substitution pump and shell can be adjusted. According to the tubing of blood and substitution, it maybe needs to adjust the gap to ensure blood flow and substitution flow.

➤ **Notes while use the equipment**

- Do not exceed the time and amount.
- Check whether the equipment and the patients with the abnormal phenomenon.
- If you find the equipment and the patient with abnormal phenomenon, you should first consider the safety of the patients, and then stop the equipment and adopt the appropriate measures.
- Do not let the patient touch the equipment.
- When connect/remove, please pay attention to the following:
  - a) Do not let air get into the patients.
  - b) Do not connect patients before rinse.
  - c) Do not let virus or drug get into the patients.
  - d) If misconnect the blood tubing, it may cause extracorporeal blood losing while taking off the tube, or extracorporeal circulation tubing broken as high pressure and threaten patients' safety, so please check whether connect well.
- According to the screen show and different procedures, do not change or adjust when it shows gray window or gray instruction and do not operate by force. When the window or instruction is bright, change or adjust is available, but operator should follow the doctors' guidance.
- Before choose operation mode, please understand its performance first. Do not change the mode and switch while treating.
- Assure the quality of water, dialysate concentrate and substitution fluid used for the equipment operation in order to secure performance and safety.
- Before treatment, do sample test on dialysate concentrate/substitution fluid to ensure the safe treatment.
- While using disposable, attention should be paid to infections by hepatitis and other

infectious drug.

➤ **Notes after the dialysis**

- In accordance with the prescriptive steps, back the operation button, switch etc. to the state before use, then turn OFF the power.
- When disassemble wires, avoid hard drag.
- Clean the accessories, wires, connectors, etc. Then sort and collect.
- After single treatment, please disinfect concentrate tube. Do not interchange concentrate tube with disinfectant tube and other tube in the machine.
- The hemodialysis equipment should be cleaned for next use. Be sure to always keep the equipment clean.

➤ **When there is something wrong, please do not repair by yourself and do some mark and call the engineer for help.**

➤ **Maintenance and check**

- Equipment and components must be checked regularly.
- When reuse the temporary stopped machine, please check the equipment whether operates normally and safely.
- If the blood or dialysate is on the equipment or on the accessories, wipe off them immediately. Do some clean and disinfection regularly.
- Do not connect any equipment other than allowed with this machine. Total leakage current of this equipment and other connected equipment may exceed the allowable value.

➤ **Do not remake the equipment and avoid furious impact on the machine.**

➤ **Resin and rubber should be dealt as industrial wastes or dealt according to local laws.**

➤ **Used battery can be sent to the local processing center or contact with our after sale service department.**

**Abbreviations**

AC	Alternating current
AP	Arterial pressure
Bicart	Bicarbonate cartridge
ETRF	Endotoxin-retentive filter
HD	Hemodialysis
HDF	Hemodiafiltration
HF	Hemofiltration
IUF	Isolated ultrafiltration
IV	Intravenous
LCD	Liquid crystal display
Pic.	Picture
RO	Reverse osmosis
TMP	Transmembrane pressure
UF	Ultrafiltration
UFR	Ultrafiltration rate
VP	Venous pressure

## Contents

<b>1 General</b>	<b>1</b>
<b>1.1 Preface</b>	<b>1</b>
<b>1.2 Safety symbols</b>	<b>1</b>
<b>1.3 Danger and warning during operation.</b>	<b>2</b>
<b>1.4 Notes during use</b>	<b>5</b>
1.4.1 Net fluid removal control	5
1.4.2 Cleaning and disinfection	5
1.4.3 Prevent carbonate crystallization	5
1.4.4 Connection of concentrate solution and cleaning port	6
1.4.5 Effective checking of the air detector	6
1.4.6 ETRF check	6
1.4.7 Static electricity	6
1.4.8 Electromagnetic interference	7
1.4.9 Operating when blood pump power off	11
1.4.10 LCD fault response	12
1.4.11 Dialysis water	12
1.4.12 Dialysis fluid concentrates	12
1.4.13 Maintenance of the pressure sensor's protective cover	12
1.4.14 Installation of the ETRF	12
1.4.15 Important information before initial start-up	14
1.4.16 Others	14
<b>1.5 Intended use</b>	<b>14</b>
<b>1.6 Indication</b>	<b>15</b>
<b>1.7 Target user group</b>	<b>15</b>
<b>1.8 Contraindications</b>	<b>15</b>
<b>1.9 Side effects</b>	<b>15</b>
<b>1.10 Intended patient population</b>	<b>15</b>
<b>1.11 Overall description</b>	<b>15</b>

---

<b>1.12 Equipment specification and technical data</b>	<b>16</b>
1.12.1 Size and weight	16
1.12.2 Electrical safety	16
1.12.3 Power supply and fuse	16
1.12.4 Operating conditions	17
1.12.5 Flow control	17
1.12.6 Dialysate composition	18
1.12.7 Substitution fluid	18
1.12.8 Dialysate concentration control	18
1.12.9 Dialysate, substitution temperature	19
1.12.10 Pressure monitor	19
1.12.11 Stability of dialysate flow, temperature and conductivity	19
1.12.12 Disinfection	20
1.12.13 Blood circuit	20
1.12.14 Technical specifications of HF/HDF	20
1.12.15 Internal electrical power source	20
1.12.16 Dialysis time	21
1.12.17 Materials	21
<b>1.13 Consumables</b>	<b>21</b>
<b>2 Composition and function</b>	<b>25</b>
<b>2.1 Models</b>	<b>25</b>
2.1.1 SWS-6000A	25
SWS-6000	25
<b>2.2 Machine appearance</b>	<b>26</b>
2.2.1 Front view of machine	26
2.2.2 Right view of machine	28
2.2.3 Left view of machine	29
2.2.4 Rear view of machine	30
2.2.5 Rear view of machine without filter cover	31

---

<b>2.3 Machine display</b>	<b>32</b>
<b>2.4 Extracorporeal blood circuit</b>	<b>33</b>
<b>2.5 Substitution circuit</b>	<b>33</b>
<b>2.6 Heparin injection unit</b>	<b>33</b>
<b>2.7 Safety monitor</b>	<b>34</b>
2.7.1 Arterial pressure detection	34
2.7.2 Venous pressure detection	34
2.7.3 Blood leak sensor	34
2.7.4 Bubble catcher and blood detector	34
2.7.5 Block clamp	34
<b>3 Installation and calibration</b>	<b>35</b>
<b>3.1 Case opening and checking</b>	<b>35</b>
<b>3.2 Temporary storage and transport</b>	<b>35</b>
3.2.1 Temporary storage	35
3.2.2 Temporary transport	35
<b>3.3 Installation conditions</b>	<b>36</b>
3.3.1 Environment	36
3.3.2 Power supply	36
<b>3.4 Requirement of dialysis water and other relevant fluids</b>	<b>37</b>
<b>3.5 Initial calibration</b>	<b>37</b>
3.5.1 Space condition of operation	37
3.5.2 Electric connection	37
3.5.3 Connection of inlet and outlet ports	38
3.5.4 Degas	39
3.5.5 Installation of ETRF	39
<b>3.6 ON and OFF</b>	<b>41</b>
3.6.1 Power supply	41
3.6.2 System power supply	41
3.6.3 Accidental power OFF	41

---

<b>4 Daily rinsing and confirmation</b>	<b>43</b>
<b>4.1 Daily rinsing of machine</b>	<b>43</b>
<b>4.2 Check before treatment</b>	<b>44</b>
4.2.1 Power supply	44
4.2.2 Dialysate	44
4.2.3 Pressure Monitor tubes	44
4.2.4 Leakage	45
4.2.5 Other checks	45
<b>4.3 Check during treatment</b>	<b>45</b>
4.3.1 Dialysate pressure and TMP	45
4.3.2 Detection of the dialysate ion concentration	46
4.3.3 Other observations	46
<b>4.4 Check after treatment</b>	<b>46</b>
<b>5 Treatment preparation</b>	<b>47</b>
<b>5.1 Preparation of machine before treatment</b>	<b>47</b>
<b>5.2 Panel indicator and keys</b>	<b>50</b>
5.2.1 LED indicator light	51
5.2.2 Keys	51
5.2.3 Screen layout	52
5.2.4 Screen keys	53
<b>5.3 Starting the system</b>	<b>54</b>
<b>5.4 Self test</b>	<b>55</b>
<b>5.5 Mode selection</b>	<b>57</b>
5.5.1 Preparation of consumables	57
5.5.2 Dialyser installation	58
5.5.3 Blood circuit installation	59
5.5.4 Installation of heparin syringe	63
5.5.5 Installation of substitution tube (if any)	63
<b>5.6 Preparation</b>	<b>64</b>

---

5.6.1 Blood circuit priming.....	65
5.6.2 Dialysate circuit priming.....	66
<b>6 Treatment.....</b>	<b>69</b>
<b>6.1 Patient connection to blood circuit.....</b>	<b>69</b>
<b>6.2 Treatment parameter settings.....</b>	<b>70</b>
6.2.1 Treatment parameter quick set.....	70
6.2.2 Alarm quick set.....	72
6.2.3 Parameter set.....	73
6.2.4 Alarm parameter set.....	75
<b>6.3 Beginning treatment.....</b>	<b>77</b>
6.3.1 Treatment interface.....	77
6.3.2 Interface Introduction.....	77
<b>6.4 Treatment Process.....</b>	<b>78</b>
6.4.1 Heparinized treatment.....	78
6.4.2 Set and adjust treatment parameters.....	80
6.4.3 Switching treatment mode.....	81
6.4.4 Temporary interruption or termination of treatment.....	81
<b>6.5 Treatment termination.....</b>	<b>81</b>
6.5.1 Blood return.....	81
<b>6.6 Post-treatment handling.....</b>	<b>82</b>
<b>6.7 Power cut handling during treatment.....</b>	<b>83</b>
6.7.1 Blood return by backup battery.....	83
6.7.2 Blood return by hand.....	83
<b>7 Alarm and measures.....</b>	<b>84</b>
<b>7.1 Alarm.....</b>	<b>84</b>
<b>7.2 Alarm categories.....</b>	<b>85</b>
7.2.1 Basic action when there is an alarm.....	85
7.2.2 Alarms related to blood.....	86
7.2.3 Alarms related to dialysate.....	86

7.2.4 Alarms related to blood and dialysate	86
7.2.5 Alarms related to interruption of power supply	87
<b>7.3 Cause and solution of alarm, caution and prompt</b>	<b>87</b>
<b>7.4 Alarm action, cause and solution</b>	<b>90</b>
<b>7.5 Measures for alarm</b>	<b>97</b>
7.5.1 VP alarm	97
7.5.2 TMP alarm	98
7.5.3 AP alarm	98
7.5.4 Blood pump alarm	99
7.5.5 Substitution pump alarm	99
7.5.6 Air alarm	100
7.5.7 Blood leakage alarm	100
<b>8 Rinse and disinfection</b>	<b>101</b>
8.1 Rinse and disinfection procedures and notes	101
8.2 Rinse and disinfection preparation	104
8.2.1 Check disinfection solution	104
8.2.2 Rinse and disinfection starting condition	105
8.3 Rinse and disinfection interface	105
8.4 Operation Process	106
8.5 Rinse and disinfection ending	106
<b>9 Single Needle - Optional</b>	<b>107</b>
9.1 Overview	107
9.2 Function Introduction	107
9.3 Parameter Settings	109
9.4 Alarms	111
<b>10 Maintenance</b>	<b>113</b>
10.1 Repair and Maintenance	113
10.1.1 Equipment external clean	113
10.1.2 Heater	113

---

10.1.3 Pump	114
10.1.4 Mains fuse changement	114
<b>10.2 Serviceman check and repair</b>	<b>114</b>
10.2.1 Internal cleaning	115
10.2.2 Confirm the protective grounding resistance is less than $1\Omega$	115
10.2.3 Confirm the accuracy of AP,VP and exterior membrane pressure sensor	115
10.2.4 Confirm the pump tube coefficient	115
10.2.5 Confirm precision of heparin pump	116
10.2.6 Confirm air detector	116
10.2.7 Confirm heater	116
10.2.8 Confirm the blood leak sensor	117
10.2.9 Confirm standby battery	117
<b>10.3 Scheduled maintenance to machine</b>	<b>117</b>
<b>11 Symbols and storage</b>	<b>118</b>
<b>11.1 Symbols</b>	<b>118</b>
11.1.1 Symbols on the equipment	118
11.1.2 Symbols on the package	119
11.1.3 Product nameplate	120
11.1.4 Product Quality Certificate	120
<b>11.2 Packaging</b>	<b>120</b>
<b>11.3 Environmental condition during delivery and storage</b>	<b>121</b>
<b>12 Electrical Principle Diagram</b>	<b>122</b>
<b>12.1 Power</b>	<b>123</b>
<b>12.2 Inlet and outlet pipeline</b>	<b>123</b>
<b>13 Appendix</b>	<b>124</b>
<b>13.1 Quality guarantee</b>	<b>124</b>
<b>13.2 Manufacturer information</b>	<b>125</b>

# 1 General

## 1.1 Preface

Thanks for purchasing SWS-6000 series hemodialysis equipment (hereinafter referred to the equipment or accessory).

This manual is for operating correctly and safely, not for patients' therapy.

This manual is for SWS-6000 and SWS-6000A.

This manual is only for health professionals, and can only be used by trained people.

Use the equipment according to this book at any time.

Before using the machine, please read this manual carefully. Operate the equipment correctly and safely on the basis of full understanding this manual.

Besides, after reading, please keep this manual with warranty at an easy-finding place near the machine.

## 1.2 Safety symbols

In order to use the equipment safely and correctly and avoid damage to body and property, there are some signs as follows. Please read the text after full understanding these icons.

Three signal words are used in this manual: DANGER, WARNING and NOTE.

The signal words DANGER, WARNING and NOTE point out particular hazardous situations for users and patients.



Indicates an imminently hazardous situation which, if not avoided, will result in death or serious injury.



Indicates a potentially hazardous situation which, if not avoided, could result in death or serious injury.



Indicates a hazardous situation which, if not avoided, could result in minor or moderate injury.

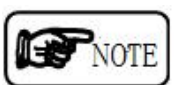

Something should be known or something should be paid attention to while operating.

### 1.3 Danger and warning during operation.



To avoid the risk of electric shock, this equipment must only be connected to a supply mains with protective earth.



Operation should under the full understanding and the supervision of the doctor.

Installations, extension, reset, adjust and repair can be done only by operator authorized by our company.



The equipment may do some wrong actions that endanger patients when disturbed by electromagnetic wave.

Please strengthen the management. Do not take the electronic communication equipments such as phone and interphone into the room or near equipment room and waiting room which the equipment is installed.



In case there is cross infection on patients by blood pollute in pressure tube of machine, we have put the protect cover (hydrophobic air filter) on the pressure tubes (VP etc.). Pay attention to the follows:

If it is certain that pressure tube is polluted by broken protect cover, please disinfect the pressure tube before using the machine.

When hydrophobic air filter is wetted by normal saline or blood, replace the filter immediately.



Before the therapy, check whether the substitution (concentrate) conforms to the prescription. If not, it will threaten patients' safety.



To avoid infection, disposable components can only be used for one time. Equipment for people who with infective diseases and who without should be separated.



The equipment may not alarm for pressure change by misconnection or broken or pinprick about blood circuit.

Please check regularly about joints outside the body circulation to confirm connecting right.

If continuing the therapy when there is a leakage, it will threaten patients' safety.

Besides, please do not cover the pontes of extracorporeal circulation. Ensure it can be monitored by eyes.



When the defibrillator is connected with patients, do not use this machine.

When defibrillator is working, please do not touch it. After working, please check machine' s condition.



Do not connect this equipment with universal socket, even using AC power plug or commutator without grounding protection; otherwise it will threaten patients' safety.



Ensure that no liquid enters the machines, and that there is no liquid on the main plug or the main socket, otherwise it may cause electric shock and fire hazard.



When using central venous catheters, higher grade for protection against electric shock is needed. Because leakage currents can pass through wires, ETRF, dialyser, tubing, patient and the conductors near patient, potential equalization terminal shall be used. Once connecting to the potential equalization terminal, the values of patient leakage current will be less than  $10\mu\text{A}$ , which complies with the requirement of type CF. Potential equalization conductor shall be connected to its terminal where it is on the switch panel.



Please set the monitor modes and alarm range of net fluid removal to satisfy the monitor modes and monitor range of filter and UFR.



About checking input data:

- Please check whether the input data is in accordance with the data of this machine. That is to say, please ensure the input data will be shown on the LCD.
- If the data shown on the LCD is different from the input data, do not start in any case.



If the dialyser is not filled with the dialysate, please do not put the equipment into therapy.



When alarm sound is off, if the alarm is still here, the alarm sound will automatically open again, and you can set the alarm volume in the system setting.



Please strengthen the management and notice. Do not let the equipment touch the fluid.

Touching the fluid will stop the machine.



When the alarm condition is satisfied and the monitoring function is opened, the equipment will alarm. But some alarms can be closed by closing the corresponding monitor. And the operator should be responsible for monitoring the protection system which has been eliminated.



Reverse UF is very dangerous. During the treatment, if the ultrafiltration does not change in 2 minutes, all of the extracorporeal circulate system will be stopped except blood



The equipment can be moved when it is not connected patients and sources.

## 1.4 Notes during use

### 1.4.1 Net fluid removal control

- While setting the net fluid removal rate, the dialyser ultrafiltration rate (UFR) will produce the transmembrane pressure (TMP) correspondingly. When the net fluid removal rate is higher than the allowable range of the dialysis hydraulic pressure or TMP, please select URF dialyser according to the net fluid removal rate.
- The net fluid removal of the equipment can be monitored by TMP while treating. But TMP can not feedback all the ultrafiltration abnormalities because of the difference of the dialyser URF.

### 1.4.2 Cleaning and disinfection

Please refer to the chapter 8 Clean and disinfect the equipment regularly.

### 1.4.3 Prevent carbonate crystallization

When bicarbonate dialysis, long time operation will cause the bicarbonate crystallization inner the equipment, then stop the machine. So pay attention to the follows:

- Please do not place the equipment for a long time when it is noted dialysate inner the machine.
- Please acid rinse the pipes regularly.

➤ Notes while acid rinsing.

- Acid should be 20~50% concentration of the citric acid solution.
- After acid rinsing, please clean thoroughly with water to ensure no acid left.
- While disinfecting with chlorine, please clean thoroughly between acid rinsing and disinfecting to avoid acid mixing with disinfection



Chlorine mixed with acid will generate chlorine gas. Inhaling such gas can threaten safety. In such an occurrence, please change the air in the room immediately and prevent further inhalation.

#### 1.4.4 Connection of concentrate solution and cleaning port

While connecting the port of concentrate A/concentrate B, the color of the port and the cleaning port should be the same.

#### 1.4.5 Effective checking of the air detector

The effective checking of air detector is automatic. Please refer to 【5.4 Self-test】

#### 1.4.6 ETRF check

If the SWS-6000 equipment is placed with ETRF and has started the HDF on line, the equipment will automatically detect the service life, the connection reliability etc. of the ETRFs.

If the self test of ETRF can not pass, please change another filter or contact engineer.

#### 1.4.7 Static electricity

Because there are a large number of electronic components in the machine, so the design is according to avoiding the impact of the electrostatic noise.

But if the equipment is impacted by huge electrostatic noise, the operation will be stopped to avoid malfunction.

At this time, please cut off the source. After checking patients' safety, power ON again.

It is easy to produce static electricity when some one is walking or change the sheets. If these people or sheets approach or touch the machine, there will be some electrostatic noises.

Especially when it is dry in the room, the voltage will rise, and the electrostatic noise will be larger. Therefore, please pay attention to maintaining proper humidity indoors.

## 1.4.8 Electromagnetic interference



SWS-6000 and SWS-6000A hemodialysis machine meet the requirement of electromagnetic compatibility in IEC 60601-1-2:2014 and IEC 80601-2-30:2009/AMD:2013.

The user needs to install and use according to electromagnetism compatibility information which is attached with it.

Portable and mobile RF communication devices may influence SWS-6000 and SWS-6000A hemodialysis machine performance, so they should be kept away from the mobile phone, microwave oven etc. during using.

Guidance and manufacturer' s declaration stated in the appendix about checking input data.



SWS-6000 series hemodialysis machine should not be used adjacent to or stacked with other equipment and that if adjacent or stacked use is necessary, the SWS-6000 series hemodialysis machine should be observed to verify normal operation in the configuration in which it will be used.

Class A equipment is intended for use in an industrial environment. The SWS-6000 series hemodialysis machine may be potential difficulties in ensuring electromagnetic compatibility in other environments, due to conducted as well as radiated The equipment may not alarm for pressure change by misconnection or broken or pinprick about blood circuit.

Table 1-1 Electromagnetic emissions

Guidance and manufacturer' s declaration –electromagnetic emissions		
<p>The SWS-6000 and SWS-6000A hemodialysis machine are intended for use in the electromagnetic environment specified below. The customer or the user should assure that it is used in such an environment.</p>		
Emissions test	Compliance	Electromagnetic environment - guidance
RF emissions CISPR 11	Group 1	<p>The SWS-6000 hemodialysis machine uses RF energy only for its internal function. Therefore, its RF emissions are very low and are not likely to cause any interference in nearby electronic equipment.</p> <p>The SWS-6000 and SWS-6000A hemodialysis machine can be used in all palce except houses and the palce connected with the public low-voltage powersupply network which is for residents' houses .</p>
RF emissions CISPR 11	Class A	
Harmonic emissions IEC 61000-3-2	Class A	
Voltage fluctuations / flicker emissions IEC 61000-3-3	Applicable	

Table 1-2 Electromagnetic Immunity

Guidance and manufacturer' s declaration – electromagnetic immunity			
<p>The SWS-6000 hemodialysis machine is intended for use in the electromagnetic environment specified below.</p> <p>The customer or the user of the SWS-6000 hemodialysis machine should assure that it is used in such an environment.</p>			
Immunity test	IEC 60601 test level	Compliance level	Electromagnetic environment –guidance
Electrostatic discharge (ESD) IEC 61000-4-2	±8kV contact ±2 kV, ±4 kV, ±8 kV, ±15 kV air	±8kV contact ±2 kV, ±4 kV, ±8 kV, ±15 kV air	Floors should be wood, concrete or ceramic tile. If floors are covered with synthetic material, the relative humidity should be at least 30 %.
Electrical fast transient/burst IEC 61000-4-4	±2 kV 100 kHz	±2 kV 100 kHz	Mains power quality should be that of a typical commercial or hospital environment.

Surge IEC 61000-4-5	$\pm 0.5$ kV, $\pm 1$ kV line(s) to line(s) $\pm 0.5$ kV, $\pm 1$ kV, $\pm 2$ kV line(s) to earth	$\pm 0.5$ kV, $\pm 1$ kV line(s) to line(s) $\pm 0.5$ kV, $\pm 1$ kV, $\pm 2$ kV line(s) to earth	Mains power quality should be that of a typical commercial or hospital environment.
Voltage dips, short interruptions and voltage variations on power supply input lines  IEC 61000-4-11	$< 5\%$ $U_T$ ( $> 95\%$ dip in $U_T$ ) for 0,5 cycle $40\%$ $U_T$ ( $60\%$ dip in $U_T$ ) for 5 cycles $70\%$ $U_T$ ( $30\%$ dip in $U_T$ ) for 25 cycles $< 5\%$ $U_T$ ( $> 95\%$ dip in $U_T$ ) for 5 s	$< 5\%$ $U_T$ ( $> 95\%$ dip in $U_T$ ) for 0,5 cycle $40\%$ $U_T$ ( $60\%$ dip in $U_T$ ) for 5 cycles $70\%$ $U_T$ ( $30\%$ dip in $U_T$ ) for 25 cycles $< 5\%$ $U_T$ ( $> 95\%$ dip in $U_T$ ) for 5 s	Mains power quality should be that of a typical commercial or hospital environment. If the user of the SWS-6000 hemodialysis machine requires continued operation during power mains interruptions, it is recommended that the SWS-6000 hemodialysis machine be powered from an uninterruptible power supply or a battery.
Power frequency (50/60 Hz) magnetic field IEC 61000-4-8	30 A/m	30 A/m	Power frequency magnetic fields should be at levels characteristic of a typical location in a typical commercial or hospital environment.
<b>NOTE:</b> $U_T$ is the a.c. mains voltage prior to application of the test level.			

Table 1-3 Electromagnetic immunity

Guidance and manufacturer' s declaration – electromagnetic immunity			
<p>The SWS-6000 hemodialysis machine is intended for use in the electromagnetic environment specified below.</p> <p>The customer or the user of the SWS-6000 hemodialysis machine should assure that it is used in such an environment.</p>			
Immunity test	IEC 60601 test level	Compliance level	Electromagnetic environment – guidance
Conducted RF IEC 61000-4-6	3Vrms 150kHz to 80MHz	3Vrms	<p>Portable and mobile RF communications equipment should be used no closer to any part of the SWS-6000 hemodialysis machine , including cables, than the recommended separation distance calculated from the equation applicable to the frequency of the transmitter.</p> <p>Recommended separation distance</p> $d = 1.2 \sqrt{P}$ $d = 1.2 \sqrt{P} \quad 80\text{MHz to } 800\text{MHz}$ $d = 2.3 \sqrt{P} \quad 800\text{MHz to } 2.5\text{GHz}$ <p>where <math>P</math> is the maximum output power rating of the transmitter in watts (W) according to the transmitter manufacturer and <math>d</math> is the recommended separation distance in meters (m).</p> <p>Field strengths from fixed RF transmitters, as determined by an electromagnetic site survey, <sup>a</sup>should be less than the compliance level in each frequency range. <sup>b</sup></p> <p>Interference may occur in the vicinity of equipment marked with the following symbol:</p> 
Radiated RF IEC 61000-4-3	3V/m 80MHz to 2.5GHz	3V/m	

NOTE 1 At 80MHz and 800MHz, the higher frequency range applies.

NOTE 2 These guidelines may not apply in all situations. Electromagnetic propagation is affected by absorption and reflection from structures, objects and people.

Field strengths from fixed transmitters, such as base stations for radio (cellular/cordless) telephones and land mobile radios, amateur radio, AM and FM radio broadcast and TV broadcast cannot be predicted theoretically with accuracy. To assess the electromagnetic environment due to fixed RF transmitters, an electromagnetic site survey should be considered. If the measured field strength in the location in which the SWS-6000 hemodialysis machine is used exceeds the applicable RF compliance level above, the SWS-6000 hemodialysis machine should be observed to verify normal operation. If abnormal performance is observed, additional measures may be necessary, such as reorienting or relocating the SWS-6000 hemodialysis machine.

Over the frequency range 150kHz to 80MHz, field strengths should be less than 3V/m.

### 1.4.9 Operating when blood pump power off

When the city electricity power off, blood pump can be operated by using the backup power. At this time, please ask professionals to monitor patients' extracorporeal circulate system.

Continuous operation time is about 40 minutes if there is enough power.

When the city electricity power off, the equipment can not operate with dialysate, such as dialysis. Please return patient' s blood. About "blood return" , please refer to 【6.5.1 blood return】

After connect the city electricity, if the battery has been replaced or the equipment has been operated after the power off, the power board will automatically charge the battery until the power is full.



Please operate the battery without patients at least once every 3 months to confirm the effectiveness of the battery charging. When the battery storage is not enough, please replace the battery in time.



Please replace the battery about every 2 years (the replace time may advance due to the use state).

### 1.4.10 LCD fault response

- The life of backlight used on the LCD (fluid crystal: With touch panel) is about 50000 hours.
- Please touch LCD panel (include the switch) with finger.
- When the LCD screen is not displayed or can not be touched, please cut off the power immediately, and then return blood by hand. (about blood return, please refer to the 【6.7.2return blood by hand】 ).

### 1.4.11 Dialysis water

The dialysis water for diluting A, B concentrate and the water for cleaning and disinfecting the equipment should have been dealt, such as RO water, pure water and soft water. And it should satisfy ISO 23500.

When the equipment is doing ONLINE HDF or ONLINE HF, the quality requirements of the dialysis water must be higher. And the dialysis water must have been confirmed by manufacture.

The national regulations with regard to the prevention of backflow into the water supply system and the air gap between drain connection and sewage connection must be observed when installing and operating the machine.

### 1.4.12 Dialysis fluid concentrates

The requirements of dialysis fluid concentrates must comply with ISO 23500.

### 1.4.13 Maintenance of the pressure sensor' s protective cover

In order to protect the patients from cross infection, there must be a sterile hydrophobic filter at the connection of extracorporeal blood circulation tube and pressure sensor. Although this measure has been adopted, the dialysis equipment can be used after cleaning and disinfection if blood flows into the pressure sensor and the pressure sensor' s protective cover.

### 1.4.14 Installation of the ETRF

As shown in pic.1-1, install two ETRFs (diacap ultra) . The dialyser connector and the ETRF connector must be installed according to this figure. Pay attention to the reliability of the connector. There shall be no water leakage and no air leakage; otherwise it may cause the equipment to abnormal operation.

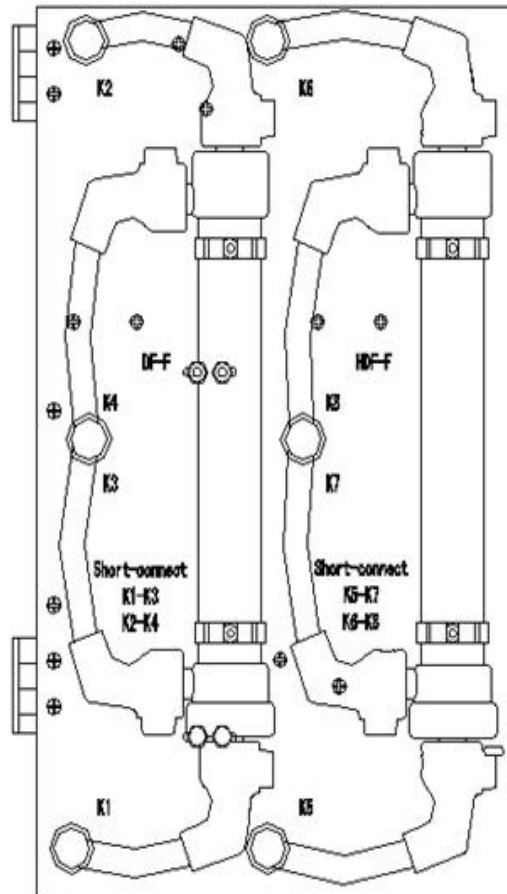

Pic.1-1 the installation figure of the ETRF

**NOTE**

The exchanged ETRF must be up to the standard new requirement. The ETRF must be used within its service life as marked in its instruction, otherwise it may bring danger.

The concentrate (A/B), disinfectant and decalcifying fluid and whatever fluid that may flow into the inner equipment must be clean, otherwise the ETRF will be blocked, and its service life will be reduced.

**WARNING**

The filter can not be used over its service life, otherwise it may bring security risks.

After exchanging the filter, please do conventional rinsing and self checking to the equipment to ensure the safe treatment.

Mustn't replace or remove the ETRF while therapy.

### 1.4.15 Important information before initial start-up

When using the central venous catheters the following precautions must be observed:

- 1、 The dialysis equipment must be connected to a potential equalization.
- 2、 If additional electro-medical devices are connected to the patient or they are positioned within the reachable area of the patient, it must be ensured that all leakage currents of these devices (device leakage current, housing leakage current, earth leakage current and patient leakage current) are below the respective limit for CF applied parts.

This means:

Maximum 10uA in normal conditions and 50uA in single fault condition.

This also applies to patient positioning devices.

Devices with leakage currents within these limits, but with an application current exceeding the specified leakage current, cannot be used, such as defibrillator equipment.

If all requirements have been fulfilled, these devices may be operated on the patient or within the reachable area of the patient, provided they are, like the dialysis equipment, integrated in to the potential equalization.

If these conditions are not fulfilled, no other additional electro-medical device must be connected to the patient or positioned within the reachable area of the patient.

In case of doubt, ask your local technician.

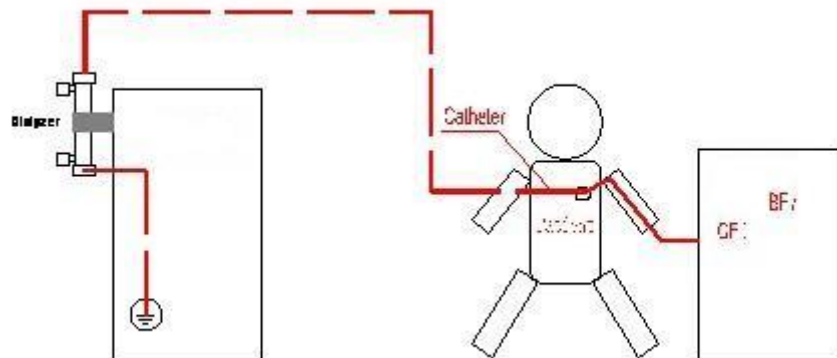

### 1.4.16 Others

To stabilize the function of this equipment for a long time and treat safely, please pay attention to checking and doing maintenance.

## 1.5 Intended use

The Hemodialysis Equipment is designed for performing chronic and acute hemodialysis.

## 1.6 Indication

Acute and chronic renal failure.

## 1.7 Target user group

The device may only be installed, operated and used by individuals with the appropriate training, knowledge and experience and who have been verifiably instructed.

## 1.8 Contraindications

- Hyperkalemia (for potassium-containing haemodialysis concentrates only)
- Hypokalemia (for potassium-free haemodialysis concentrates only)
- Uncontrollable coagulation anomalies

A different method of extracorporeal treatment may be indicated in haemodynamically unstable patients.

## 1.9 Side effects

Haemodialysis therapies occasionally cause hypotension, nausea, vomiting and cramps in some patients. Please read the package inserts enclosed with the haemodialysis concentrates and dialysers, etc.

To reduce possible side effects of the treatment, the therapy specification should be customised for the patient.

## 1.10 Intended patient population

Treatment of patients with a body weight of 40 kg or more.

## 1.11 Overall description

The machine include: blood system(blood pump, substitution pump(SWS-6000), heparin pump, block clamp, air detector, blood detector, VP/AP monitor), hydraulic system(degas system, heating system,mixing system, balance system, UF system, substitution generative system(only for SWS-6000), bicarbonate cartridge (Abbreviation bicart, optional)), monitor system(conductivity monitor, temperature monitor, VP monitor, power monitor, communication monitor), power system (city power, battery),interface(LCD, touch screen and control keys);

The machine does not include the consumable, such as dialyser, filter, blood tube and puncture needle etc.

## 1.12 Equipment specification and technical data

### 1.12.1 Size and weight

- The size (not including projections)
  - Height: 1515mm
  - Width: 465mm
  - Thickness: 785mm
- The size (including hook and side lever etc. Projections)
  - Height: 1700mm
  - Width: 700mm
  - Thickness: 995mm
- Weight
  - Standard equipment: 87kg
- **IV pole load-bearing**
  - The IV pole single hook load is less than 1kg, and the IV pole hook whole load is not more than 4kg. Please do not exceed the hook load capacity.

### 1.12.2 Electrical safety

- Equipment type
  - Class I, type B, continuous operation, mobile equipment
- 93/42/EEC according to EC medical machinery directive
  - Class IIb
- Degree of protection
  - Protection against vertically dripping: IPX1

### 1.12.3 Power supply and fuse

- Power supply
  - Voltage: ~ 100-240V
  - Frequency: 50/60Hz
  - Power consumption: ≤2000VA
  - Average energy consumption at water inlet temperature of
    - 10°C: Max. 5 kW · h
    - 20°C: Max. 3.2 kW · h
- **Standby battery**
  - Type: Maintenance-free lead-acid battery
  - Capacity: 2×12V/4Ah
- Power fuse

The AC fuse of the complete machine: 2×15A/250V

Battery fuse: 1×F10AL250V

- Leakage protector  
Residual operating current: 10mA

## 1.12.4 Operating conditions

- Environment condition  
Environment temperature: 10°C ~ 40°C  
Relative humidity: ≤85%  
Atmospheric pressure: 70 kPa~106 kPa  
Energy emission to ambient air: 0.2 kW · h (during treatment)  
Energy emission to drain at water inlet temperature of  
——10°C: Max. 4 kW · h  
——20°C: Max. 2.55 kW · h
- Water supply  
**Water inlet pressure: 0.5bar ~ 8.0bar**  
**Water inlet temperature: 5°C ~ 30°C**  
Water inlet flow rate: Max. 1.2l/min  
Water consumption in therapy: 500ml/min (120l in 4h)  
Max. drain temperature: 95°C
- Concentrate supply  
Pressure: 0 ~ -100mbar  
Concentrate consumption: 31.8ml/min (14.3ml/min for using bicarbonate dry powder)
- Central Delivery System (optional)  
Pressure: 0 ~ 500mbar  
Temperature: 15°C ~ 35°C  
Flow: max.30ml/min

## 1.12.5 Flow control

- Blood flow rate  
**Flow rate range:0, 30 ~ 600ml/min**  
Flow rate deviation: ±10ml/min or ±10%, of whichever is greater  
Pre-pump arterial pressure: -200mmHg ~ 0  
After-pump arterial pressure: 0 ~ 200mmHg
- Dialysate flow rate  
**Flow rate range: 0, 100 ~ 1000ml/min**  
Flow rate deviation: ±5%
- Net fluid removal (Net fluid removal)

Ultrafiltration (UF) control: Volume-controlled via balance chambers, UF through ultrafiltration pump

Protective system: Independent monitoring of accumulated UF volume

Flow rate range: 0 ~ 4000ml/h

Flow rate deviation:  $\pm 1\%$  or  $\pm 30\text{ml/h}$ , of whichever is greater

Accumulative deviation: Less than  $\pm 200\text{ml}$

➤ Substitution flow rate

Flow rate range: 30ml/min ~ 350ml/min(6.3/9.8mm)

Flow rate deviation:  $\pm 10\text{ml/min}$  or  $\pm 10\%$ , of whichever is greater

➤ Heparin flow rate

Flow rate range: 0 ~ 10ml/h

Flow rate deviation:  $\pm 0.2\text{ml}$  or  $\pm 5\%$ , of whichever is greater

Pressure: 0 ~ 500mmHg

Bolus volume range: 0.1 ~ 5ml

Syringe type: 10ml, 20ml, 30ml or 50ml

## 1.12.6 Dialysate composition

Dialysate composition (The ion concentration mmol/l of the dialysate A&B composition is mixed by dilution proportion according to the requirement of table 1-4).

Table 1-4 Dialysate composition (A.B)

Ion	Na <sup>+</sup>	K <sup>+</sup>	Ca <sup>2+</sup>	Mg <sup>2+</sup>	Cl <sup>-</sup>	HCO <sub>3</sub> <sup>-</sup>	CH <sub>3</sub> COO <sup>-</sup>
Nominal	140	2.1	1.5	0.5	106	38	4.0
Deviation	$\pm 2.5\%$	$\pm 5\%$	$\pm 5\%$	$\pm 5\%$	$\pm 5\%$	$\pm 5\%$	$\pm 5\%$

## 1.12.7 Substitution fluid

➤ Substitution fluid quality

Endotoxins:  $\leq 0.03\text{EU/ml}$

➤ Online HDF/HF

Method: Use double ETRFs (Double filtration)

Endotoxins via single filter:  $\leq 0.03\text{EU/ml}$

## 1.12.8 Dialysate concentration control

➤ Resolution and accuracy

Indication resolution: 0.1mS/cm

Indication range: 0 ~ 25.5mS/cm

Accuracy:  $\pm 0.1\text{mS/cm}$

➤ Concentration control

Protective system: Independent conductivity sensor  
Conductivity control: 12.5mS/cm ~ 16.0mS/cm  
Accuracy:  $\pm 0.1$ mS/cm  
Alarm window width:  $< \pm 5\%$  around the actual value

## 1.12.9 Dialysate, substitution temperature

Selectable range: 33°C ~ 40°C  
Accuracy: Dialysate  $\pm 0.5$ °C, substitution  $\pm 1$ °C  
Protective system: Independent temperature sensor  
Alarm limits: 33°C ~ 40°C

## 1.12.10 Pressure monitor

### ➤ TMP monitor

Range: -60mmHg ~ 520mmHg  
Accuracy:  $\pm 10$ mmHg  
Alarm limit: -60mmHg ~ 500mmHg, alarm deviation  $\pm 5$ mmHg, stop UF during the audible alarm

### ➤ VP Monitor

Range: -60mmHg ~ 520mmHg  
Accuracy:  $\pm 10$ mmHg  
Alarm limit : 10mmHg ~ 200mmHg, alarm deviation  $\pm 5$ mmHg  
Protective system: Test prior to start of therapy. VP limits are monitored by the function and control system.

### ➤ AP Monitor

Range: -300mmHg ~ 280mmHg  
Accuracy:  $\pm 5$ mmHg  
Alarm limit: -300mmHg ~ 280mmHg, alarm deviation  $\pm 5$ mmHg.

### ➤ Blood coagulation monitor

Alarm limit: 0 ~ 600mmHg  
Protective system: The difference value of AP minus VP is monitored by the function and control system.  
During treatment, AP is greater than VP and their difference value keeps greater than setting value for 30 seconds, then blood coagulation alarm is activated.

## 1.12.11 Stability of dialysate flow, temperature and conductivity

➤ Dialysate flow:  $\leq 5\%$

- Dialysate temperature:  $\leq 0.5^{\circ}\text{C}$
- Dialysate conductivity:  $\leq 0.5\text{mS/cm}$

### 1.12.12 Disinfection

- Outlet temperature:  $\geq 93^{\circ}\text{C}$
- Heat disinfection:  $\geq 15\text{min}$
- Chemical disinfection  
Refer to 【Chapter 8 disinfection】

### 1.12.13 Blood circuit

#### ➤ Blood leakage sensor

Detection way: Color recognition, light Monitor.

Detection sensitivity: Under the specified maximum of the dialysate flow rate and the ultrafiltration flow, the maximum alarm limit value of blood leakage rate should be  $\leq 0.35\text{ml/min}$  (blood hct 32%).

#### ➤ Air detector

Detection way: Ultrasonic fluid level detection model (tubing type bubble detection)

Detection location: The venous tube

Detection sensitivity: The bubbles size is more than 0.02 ml or the tiny bubbles size is more than 0.0003ml.

#### ➤ Blood detector

Detection way: Optical detection.

Suitable blood tubing: Blood tube.

#### ➤ Block clamp

Action way: Electric pulse normally closed.

Reset way: Manual operation.

### 1.12.14 Technical specifications of HF/HDF

- The substitution fluid pump  
Setting range: 30ml/min ~ 450ml/min(6.3/9.8mm)  
Flow accuracy:  $\pm 10\%$  of setting value  
Outlet pressure: Maximum 66.7 kPa

### 1.12.15 Internal electrical power source

In the event of an interruption of the power supply to the machine, the blood pump can work more than 40min on the condition that battery was fully charged.

## 1.12.16 Dialysis time

Dialysis time: 10 minutes to 24 hours.

Accuracy:  $\pm 2s$  or  $\pm 1\%$ , of whichever is greater.

## 1.12.17 Materials

Materials coming into contact with the dialysis water, dialysis fluid and dialysis fluid concentrate:

Material name	Abbreviation
Silicone	—

## 1.13 Consumables

The dialysis fluid produced by the device is in indirect contact with the patient's blood at the dialyzer.

The machine is a power plant of the extracorporeal blood circulation, which doesn't include the routine consumables contacting with the human body. Such as dialyser, filter, ETRF, extracorporeal circuits etc. The consumables complying with national standards or industry standards can be used together with this equipment. These can also be bought from supplier of this equipment. The recommended supporting consumables are shown in the tables below (Table 1-5, Table 1-6, Table 1-7).



Please use registered consumables.

For disposable products (eg: blood circuit, dialyser, syringe etc.), please abandon them according to relevant laws and regulations.

If the consumables are not in the range of recommend, please check with manufacturer before using.

Table1-5 Commonly used dialysers

No.	Manufacturer	Model	Note
01	Fresenius	F6HPS F8HPS	Polysulfone membrane
02	Fresenius	FX60 FX80	

No.	Manufacturer	Model	Note
03	B.BRAUN	LOPS12 LOPS15	
04	GAMBRO	Polyflux 14L	

➤ Filters

Table 1-6 Commonly used filters

No.	Manufacturer	Model	Note
01	Fresenius	FX60 FX80	Polysulfone membrane
02	Fresenius	F60(S) F70(S)	
03	Fresenius	HF80(S)	
04	B.BRAUN	HIPS15	
05	GAMBRO	140H	

➤ ETRFs

Table 1-7 Commonly used ETRFs

No.	Manufacturer	Model
01	B.BRAUN	Diacap Ultra Dialysis Fluid Filter
02	Dialife	ULTRADIA 201A

➤ Dialyser and filter

The requirements of dialyser and filter must satisfy with ISO 8637-1.

➤ Extracorporeal circuits

The requirements of extracorporeal circuits must satisfy with ISO 8637-2.



The blood circuit should suit the pressure produced by blood pump.

Please ensure there is no bacterium in the blood and dialyser connectors.

- Puncture needle  
The requirements of puncture needle must satisfy with ISO 7864.
  - Syringe  
Model 10 ml, 20 ml, 30 ml, 50 ml
  - Hydrophobic air filter (with hook lock)
  - Concentrates
    - Acetate dialysis  
The acetate solutions can be used if they satisfy the following ratio:  
Acetate solution: Water=1 : 16 ~ 1 : 46
    - Bicarbonate dialysis  
The A、 B solution can be used if they satisfy the following ratio:
    - A solution:B solution: Water:  
1 : 1.83 : 34 (the NaCl is contained in B solution)  
1 : 1.225 : 32.775  
1 : 1.83 : 32.17  
1 : 1.26 : 32.74  
1 : 2.1 : 34  
Customize ratio
- Set the exact formula according to actual concentration on site.



The size and proportion of the dialysis powder must be in line with the proportion provided by this machine, otherwise the dialysate proportion will be out of control, and threaten patients' safety, even cause the machine proportion system out of control.

If it is needed to choose different proportion with the machine, please contact with the professionals. Do not use or operate by yourself.



If choose the ratio of 1:1.83:34 formulations, it is needed to confirm whether the NaCl is contained in B concentrates. Otherwise it will bring security risks.

If choose the ratio of 1:1.83:34 formulas do not use Bicart powder. Otherwise it will bring security risks.

➤ Bicarbonate dry powder

The requirements of bicarbonate dry powder must satisfy with ISO 23500-4.

➤ Disinfection solution and acid solution

Sodium hypochlorite 5%

Citric acid 30%



Please do not use overdue disinfections.

Keep disinfection solution safely

The actual used citric acid concentration must be the same with machine set.

## 2 Composition and function

The equipment consists of blood pump, substitution fluid pump (only for SWS-6000), heparin pump, fluid inlet module, fluid mixing module, balance control module, monitoring module, keyboard, display module, alarm module and special software etc. It doesn't include consumables such as dialyser, filter, blood tubing and puncture needle and so on. The functions of equipment include hemodialysis, hemofiltration (only for SWS-6000), hemodiafiltration (only for SWS-6000), isolated ultrafiltration, sequential therapy, prime, rinse and disinfection etc.

### 2.1 Models

SWS-6000 series hemodialysis machine contains two models: SWS-6000A (single pump), SWS-6000 (with on-line hemodiafiltration function).

#### 2.1.1 SWS-6000A

##### **【Optional accessories】**

- **Bicart holder** (refer to 2.2.2)

##### **【Treatment modes】**

- **HD**
- **IUF**

#### SWS-6000

In addition to hemodialysis, Online HDF machines offer the therapy modes hemodiafiltration (HDF) and hemofiltration (HF), in which substitution fluid is prepared online by the machine.

##### **【Optional accessories】**

- **Bicart holder** (refer to 2.2.2)

##### **【Treatment modes】**

- **HD**
- **IUF**
- **ONLINE HF**
- **ONLINE HDF**



Only the disinfection procedures defined and validated by the manufacturer shall be used for ONLINE HDF and ONLINE HF.

## 2.2 Machine appearance

### 2.2.1 Front view of machine

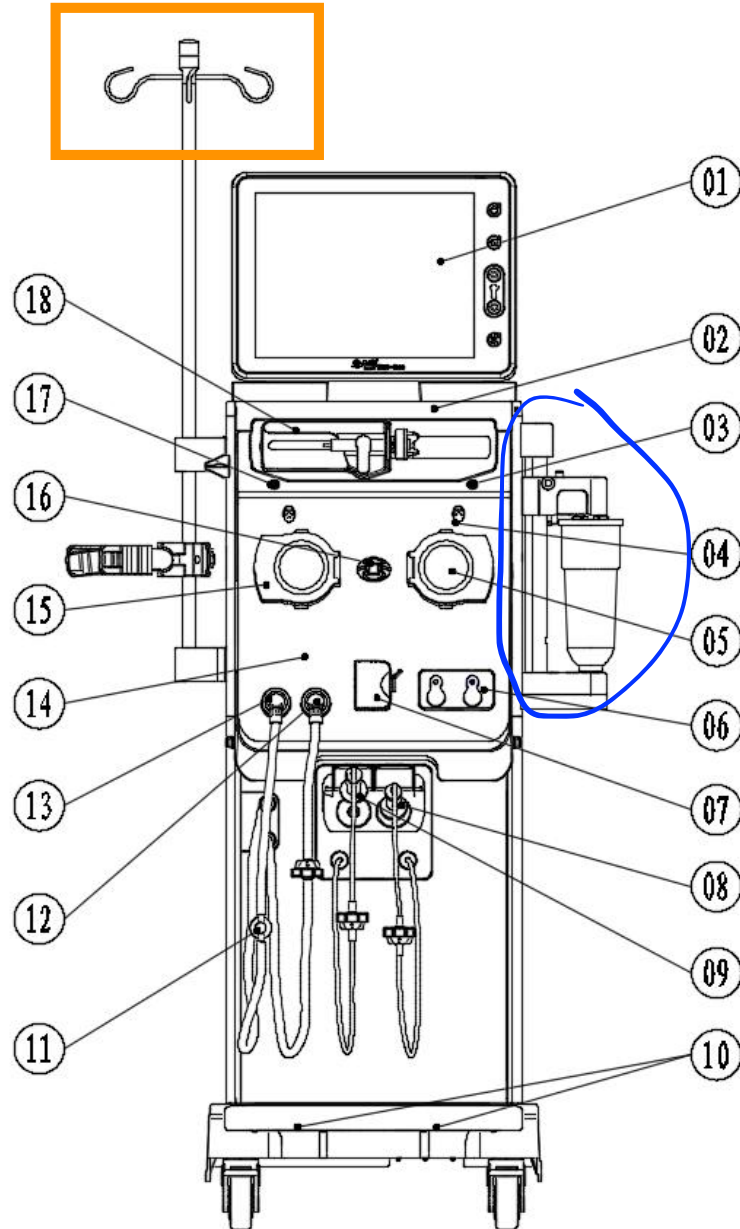

Pic. 2-1 The front view of the machine

Table 2-1 The name and the performance of the equipment front view

No.	Name	Performance
01	Mask and LCD components	Composed of a series of buttons, lights and LCD screen, used for operating machine and display information.
02	Shell	Support and fix all the components of the machine.
03	Pressure monitor connector (venous)	Used for Monitor venous pressure and filter membrane pressure
04	Tube clamp	Used for fastening tubes
05	Substitution pump	Provide power for substitution fluid(only used for SWS-6000)
06	Substitution installation	The outlet port of ONLINE HF/ONLINE HDF substitution pump
07	Clamp	Detect whether the air is in the blood tube. When it is closed, it can stop blood in the extracorporeal tube flowing into body.
08	B fluid connector (blue)	Absorb B fluid
09	A fluid connector (red)	Absorb A fluid
10	The seat for A/B fluid container	Place concentrated container (A.B fluid)
11	Sample port	Used for sampling from dialysate tube
12	Dialyser connector (blue)	Connected with the dialyser while treatment, connected with the machine while cleaning and disinfecting
13	Dialyser connector (red)	Connected with the dialyser while treatment, connected with the machine while cleaning and disinfecting
14	Cover	used to install blood pump, substitution pump, heparin pump, and can be rotated to open.
15	Blood pump	Provide power for blood extracorporeal circulate
16	Bubble catcher base	Fasten venous pot
17	Pressure monitor connector (arterial)	Used for Monitor arterial pressure
18	Heparin pump	Inject heparin into blood

## 2.2.2 Right view of machine

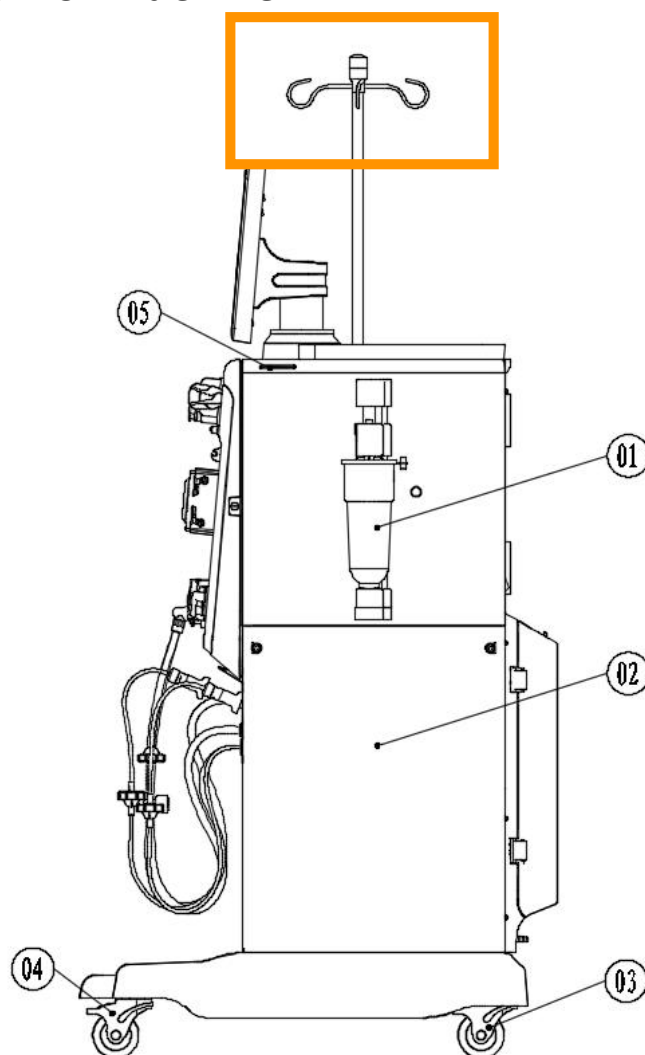

Pic. 2-2 The right view of the machine

Table 2-2 The name and the performance of the equipment right view

No.	Name	Performance
01	Bicart	Optional, used for preparing B concentration
02	The inferior cover plate	The right cover plate of the water circuit
03	Rear roller	Used for supporting and moving machine
04	Front roller(with brake)	Used for supporting ,moving and fixing machine
05	IC card slot	Insert the IC card,to record the information of patients and engineers

### 2.2.3 Left view of machine

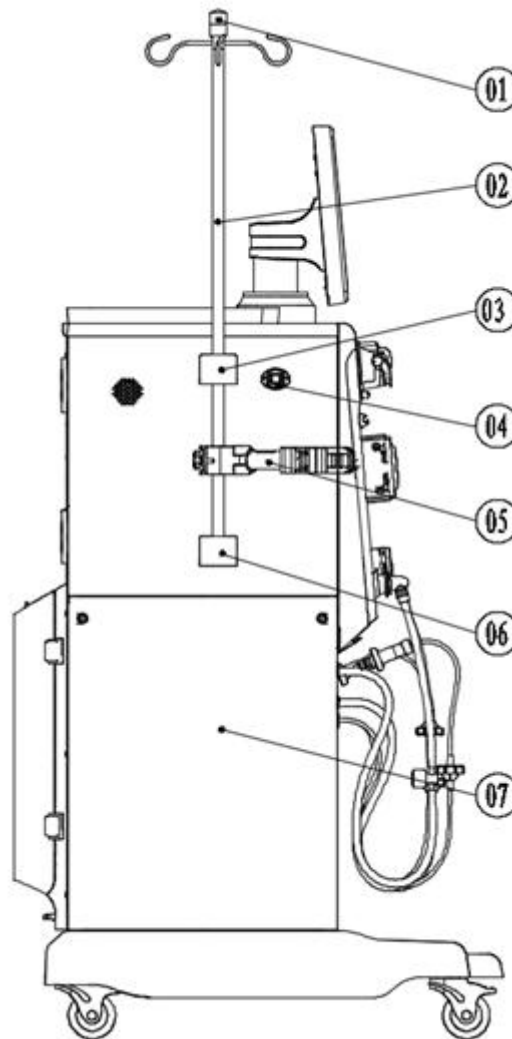

Pic. 2-3 The left view of the machine

Table 2-3 The name and the performance of the equipment left view

No.	Name	Performance
01	Indicator light	The different color can display different state of the machine. Display alarm information.
02	IV pole	Fix dialysate clamp, hanging infusion and substitution fluid container etc.
03	IV pole—upper bearing	Fix IV pole
04	Bubble catcher(arterial)	Fix arterial pot
05	Dialysate clamp	Fix the dialyser
06	IV pole inferior bearing	Fix the IV pole
07	Inferior cover plate	The left cover plate of the water circuit

## 2.2.4 Rear view of machine

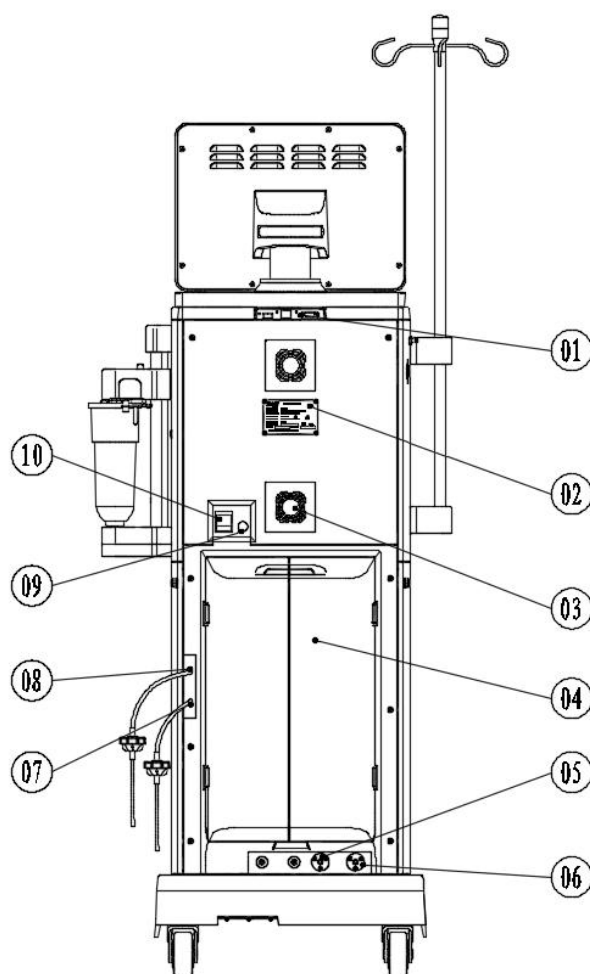

Pic. 2-4 The rear view of the machine

Table 2-3 The name and the performance of the equipment rear view

No.	Name	Performance
01	Data connector	Connect instruments such as netting twine, data wire, computer etc
02	Machine brand	The name of the product, type and the information.
03	Air fan	The air exchange and heat radiation inside and outside
04	Filter cover	The rear cover plate of the water circuit
05	Outlet port	Waste outlet port
06	Inlet port	Dialysate inlet port
07	decalcification(heat disinfection) port	absorb decalcification and deironing solution
08	disinfection port	absorb disinfection solution
09	Power wire outlet port	Connect the power wire of the power plug
10	Power switch	Connect or cut off the main machine power

## 2.2.5 Rear view of machine without filter cover

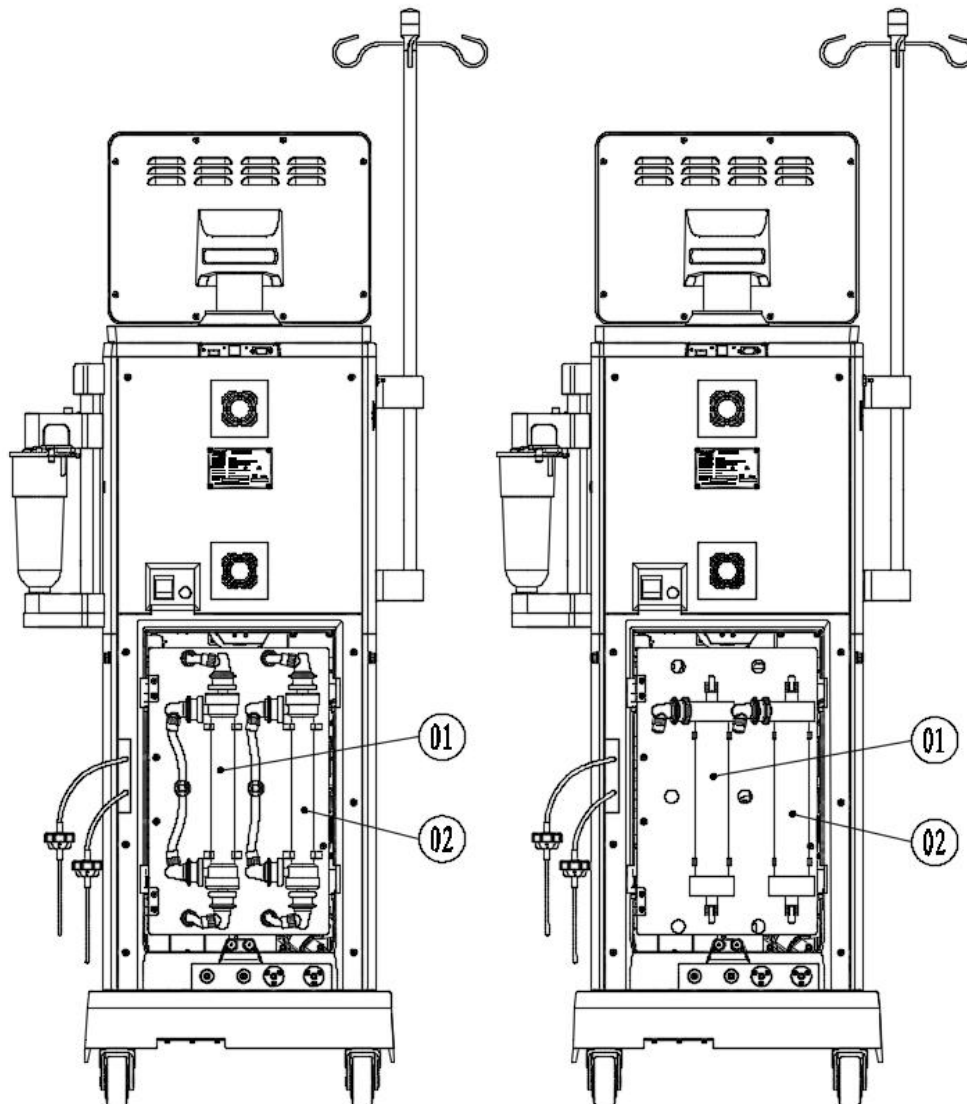

Pic. 2-5 The rear view of the machine (without filter cover)

Table 2-5 Name and the performance of the rear view of the machine (without filter cover)

No.	Name	Performance
01	Dialysate filter(the first class)	Remove heat source, bacteria, impurities etc in the dialysate.(optional in SWS-6000A)
02	Dialysate filter(the second class)	Remove heat source, bacteria, impurities etc in the dialysate again .(only used in SWS-6000)

## 2.3 Machine display

The Display of the machine as pic.2-5:



Pic. 2-5 Operate display

Table 2-6 The functions of the operate display

No.	Name	Function
1	Touch screen	The display is user interface, the user can click to operate machine and set parameter.
2	Power on/off key	Power key:If the machine is turn off,touch it to turn on the machine If the machine is turn on,press it in long time at least 3s. to turn off. Power indicator: Power off,green light is out Connect the power. when machine is off, green light is flicker Connect the power ,when machine is on,the light is green
3	Blood pump on/off key	Blood pump switch :touch it to turn on/ off blood pump Blood pump indicator:Stop the blood pump, green light off Start the blood pump,green light on
4	Level "▲" Key	Increase the fluid level in the venous pot by long time press
5	Level "▼" Key	Reduce the fluid level in the venous pot by long time press
6	" Mute" Key	Mute key:touch it to turn on/turn off the mute Mute indicate:turn off the mute,green light off Turn on the mute,green light on

## 2.4 Extracorporeal blood circuit

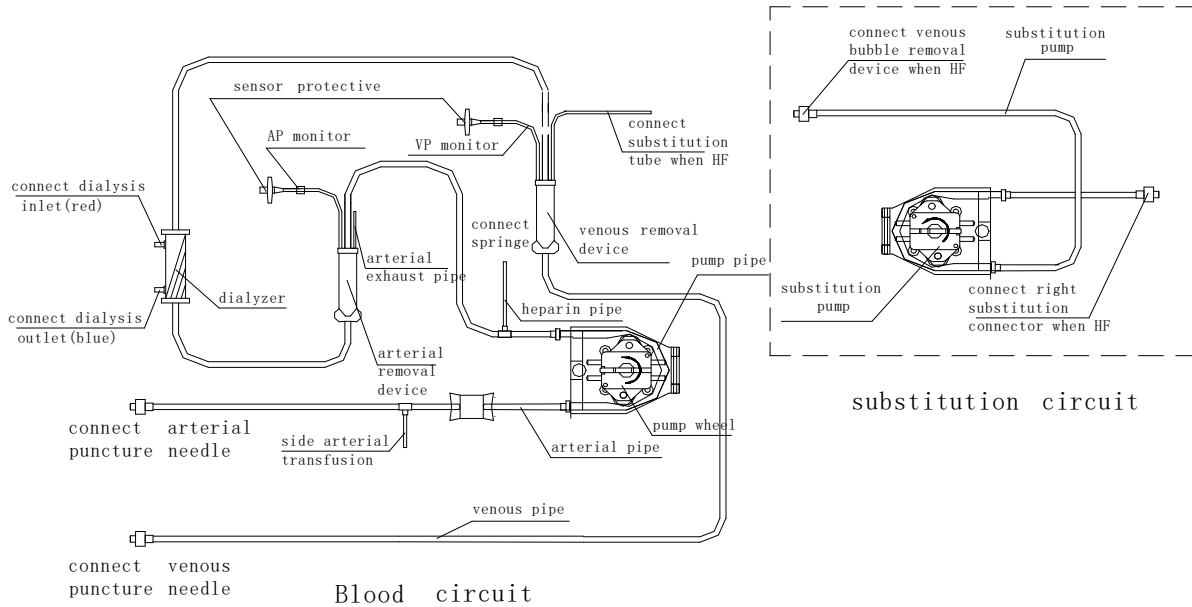

Pic. 2-6 The extracorporeal blood circuit

**Remark:** "arterial removal device" is arterial pot.

"venous removal device" is venous pot.

## 2.5 Substitution circuit

The diagrammatic sketch of the substitution is as follows. Please refer to 5.5.5 the detailed operation procedure.

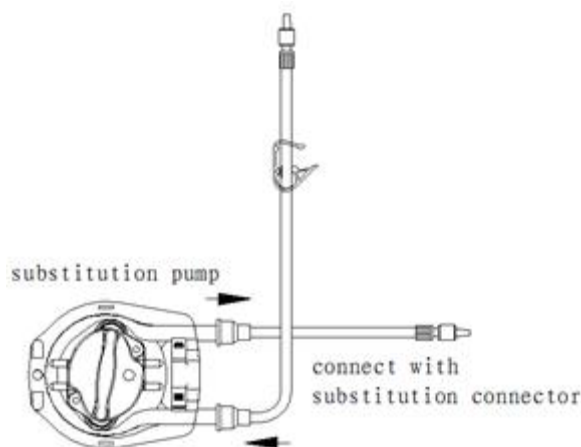

Pic. 2-7 The on-line substitution circuit

## 2.6 Heparin injection unit

The heparin injection system consists of the heparin pump. Its function is to inject heparin

slowly into arterial blood to prevent blood from coagulation.

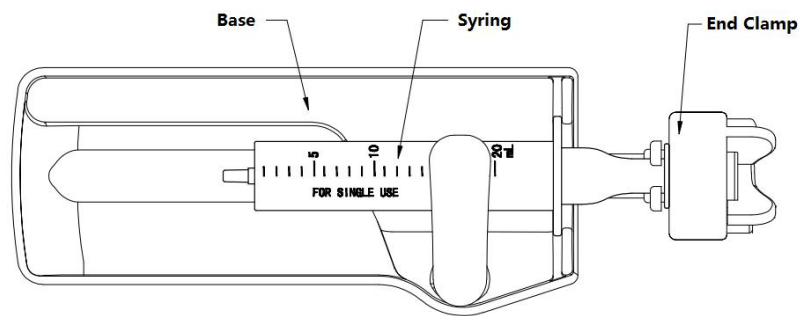

Pic. 2-8 Heparin injection unit

## 2.7 Safety monitor

The safety guarantee system consists of pressure detector (arterial pressure, venous pressure, dialysate outer membrane pressure, and substitution pressure), blood leak sensor, blood circuit bubble catcher, substitution bubble catcher, block clamp etc. Please refer to 【the 7<sup>th</sup> chapter alarm and measure】

### 2.7.1 Arterial pressure detection

It is used to detect the pressure of the fluid which is in the extracorporeal arterial blood tube (between blood pump and filter).

### 2.7.2 Venous pressure detection

It is used to detect the pressure of the fluid which is in the extracorporeal venous blood tube (post-filter and pre-human body)

### 2.7.3 Blood leak sensor

It is used to detect whether the red blood cell is in the wastes and whether there is the blood leakage in the filter.



False blood leak alarm when dialyzing patients treated with Hydroxocobalamin (or any form of Vitamin B-12)

### 2.7.4 Bubble catcher and blood detector

It is used to detect whether the bubble and blood is in the returning blood.

### 2.7.5 Block clamp

It will close automatically to stop extracorporeal venous blood.

# 3 Installation and calibration

This chapter is to illustrate installation environment condition, opening box, installation, disposing wires, packing stuffs and discard machine.



The installer must have been trained professionally and hold the certificate.

## 3.1 Case opening and checking

Before opening the box, please check whether the numbers on the package is the same with products numbers on the equipment nameplate.

According to the packing lists, check whether the accessories and documents are complete, and whether the equipment and accessories are broken.

If you find some broken, please contact with after-sale service department.



While opening the box, the box maybe fall down to cause hurt to persons.

## 3.2 Temporary storage and transport

### 3.2.1 Temporary storage

- Disinfect to the dialyser.
- Reserve should refer to formula10.5.
- The SWS-6000 on-line should be online disinfected at least once a week.
- If the reserve time is more than one month, it is needed to inform professionals to empty the machine.

### 3.2.2 Temporary transport

Transport without package

- Release the stoppers of two front wheels
- move dialyser to appointed place by the wheels under the dialyser
- lock the stoppers of two front wheels



Incorrect transportation methods may damage the equipment.



When transferring equipment through steps or slopes, the number of personnel should not be less than 2! When moving, do not load anything on the table or hook of the equipment! When lifting the device, be sure to raise the bottom frame to avoid stress on the plastic body and the parts on the surface of the body!



If the equipment is tilted more than 10°, it may fall over and cause injury to personnel and equipment.

If carry the dialysis machine by hand, the base, rear board and/or spine in the front of the machine should be held.

### 3.3 Installation conditions

For safety and operation correctly, the installation scene must satisfy the following conditions:

#### 3.3.1 Environment

Temperature: 10°C ~ 40°C

Relative humidity: ≤85%

Atmospheric pressure: 70 kPa~106 kPa

#### 3.3.2 Power supply

Voltage: ~100-240V

Rate: 50/60Hz

Input power: ≤2000VA



Do not use unsafely grounding AC power socket and wiring board!  
Do not insert the socket after connecting the machine' s plug with wiring board.



The mains wall socket or the mains socket of the machine must remain accessible to ensure that the mains cord can easily be disconnected to completely isolate machine from mains supply.



Make sure that the power plug is completely inserted into the socket, otherwise you may suffer an electric shock.

## 3.4 Requirement of dialysis water and other relevant fluids

Users must monitor the quality of the dialysis water regularly.

The dialysis water and other relevant fluids must satisfy local relative standards or regulations.

## 3.5 Initial calibration

### 3.5.1 Space condition of operation

While using the machine, the upper space should be more than 15cm, each side should be more than 10cm, and the rear space should be more than 20cm.

### 3.5.2 Electric connection

- The source voltage should match the set voltage marked in the equipment brand.

NOTE: The source cable should not be lengthening cable or adapter.

- The installation of electricity in operation room must satisfy the relative rules.
- The machine must be grounding correctly.

About further information, please contact with after-sale department.

### 3.5.3 Connection of inlet and outlet ports

The inlet port and outlet port are installed in the bottom of crate below cover, refer to Pic.3-1.

The external tubes connected with inlet port, after it is connected well, you should tight around the port with red tape immediately; the external tubes connected with outlet port, after it is connected well, you should tight around the port with blue tape immediately.

The inlet tubes and outlet tubes in the accessories are 10mm diameter pressure tubes. When installation, the pressure tubes should be cut into two parts, one is inlet tube, the other is outlet tube. After connecting ports well, you should fasten them with metal belt.

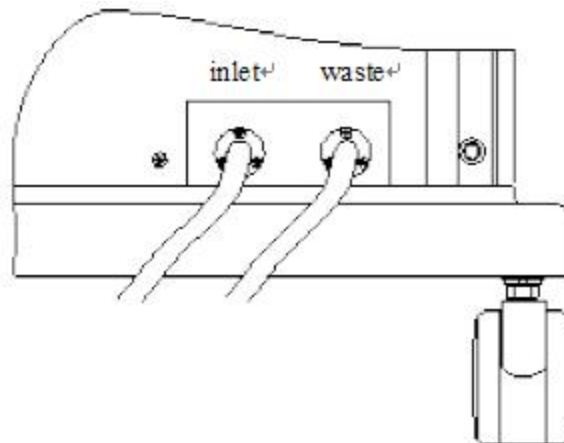

Pic. 3-1 The picture of inlet port and outlet port connection



While installation or maintenance, do not confuse the water inlet with fluid outlet, otherwise there is risk of electric shock.



While installation or maintenance, do not confuse the water inlet with dialysis fluid concentrate connectors, otherwise there is risk of electric shock.



To prevent the siphonage effect in outlet tube, the waste tube bottom must be hung in the air when waste tube inserts into sewer, and it should not touch the wastes. The outlet hose can not touch the wastes in outlet tube.

Do not touch the outlet tube while there are hot fluids in the tube.

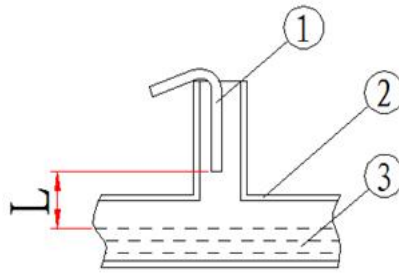

Pic. 3-2 The picture of outlet tube installation

1. Waste tube      2. Sewer      3. Waste in the sewer

### 3.5.4 Degas

There is full of air in the tubes when the machine is out of factory. Please degas as follows:

Turn on the machine, pass disinfection and self-test, then HD for about 5min (A/B aspiration can be inserted into RO water), until the degas valve is on the state of close under the "technical mode" .



For the equipment with bicart (optional), while degassing at the first time, you should switch off the heater. When start to operate with water, you can repeatedly cut off or switch on 3×7 silicone tube on the QG2 by clamp, until the water in every tank is at the fluid level (the water in QG1 and QG2 should reach to half the

### 3.5.5 Installation of ETRF

Refer to the pic. 3-3 to install the ETRF (diacap ultra), please notice that the dialysate couplings and the ETRF should be contacted according to the pic. And also notice that all the connectors should be connected tightly without leakage.

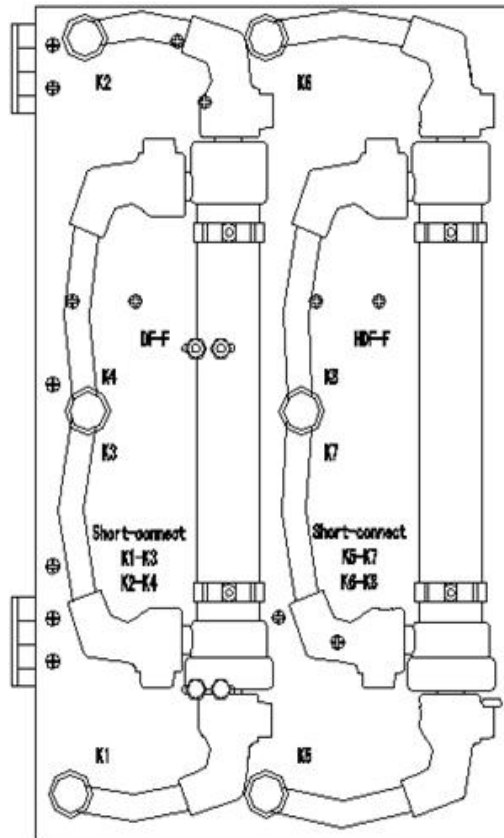

Pic. 3-3 The installation for ETRF



The ETRF must be satisfied and new.

The ETRF must be used within its labelled life time.

The A/B concentrate, disinfection fluid, decalcification fluid and any other fluid which can enter the machine must be clean. Otherwise the ETRF may be blocked and its lifetime will be reduced.



The ETRF can not be used upon its lifetime, because it will bring danger.

After exchange the endotoxin, it is needed to do rinsing and self-testing to ensure treatment safely.

## 3.6 ON and OFF

### 3.6.1 Power supply

The power supply is located in the middle of the rear.

Switch between "O" And "I" by flipping the switch button.

Do not touch this switch while operation normally. It should be "I" .

Before moving the machine, you should switch off the system power, and put this switch into "O" . While finishing the installation, it should be "I" .



If the state of this switch is "I" and the city electricity is unusable, the system also can be started by "POWER" . At this time, the inner power will be consumed. But the excessive consuming will reduce battery' s lifetime and will cause operation abnormal.

### 3.6.2 System power supply



- On the top right corner of the screen is the on/off key, as the picture 
- If the LED is green flicker, system is OFF. Hold pressing the key for 2 ~ 3s to start the machine, At this time, the LED is green.
- When the system is ON, hold pressing the key, at least for 5s to OFF the power forcibly, at this time the LED is green flicker.
- When the city electricity is unavailable and the power supply is "OFF" , the LED does not display.
- Automatically ON or OFF is not controlled by the key.
- You can set automatically ON or OFF time at the "system set" Window.
- After finish the cleaning and disinfection, the system will automatically OFF.

### 3.6.3 Accidental power OFF

If touched the power supply while treatment or disinfection, and the power is OFF, you can handle by following these methods:

- press the switch again.
- the alarm information will show on the screen: "Abnormal OFF, whether to recover

last state?"

- Press "OK" To recover last treatment parameters before last OFF. Operator can choose again to enter this treatment mode.
- If the interval is less than 15 min, you can continue treatment. If the interval is too long, the indication will be still here.
- If touched the power supply while disinfection and the power is OFF, when ON the machine again, it will execute rinse for 10 min forcibly.

# 4 Daily rinsing and confirmation

To ensure machine' s performance and operation, it is important to operate correctly, maintain and check daily.

## 4.1 Daily rinsing of machine

- OFF the power and disconnect the power plug.
- Use dry soft cloth to clean the dirty parts. When it is dirty too much, use soft cloth to dip in neutral detergents or disinfectant alcohol which are diluted with water, then wring them to erase.
- At last, use dry cloth to erase moisture.
- When it is needed to disinfect surface, use soft cloth to dip in diluted sodium hypochlorite solution (maximum concentration is 0.5%), then wring them to erase. Finally, use dry cloth to erase moisture.
- According to the guidance of rinsing fluid, use alcohol (max concentration is 70%) or isopropanol (max concentration is 60%) to clean the surface and LCD.
- Do not use sodium hypochlorite (bleaching agent) directly, and it can not be used in cleaning LCD.
- The LCD can be cleaned by superfine fiber with distilled water or the targeted commercial touching careen cleaning agent.
- Use 30~50% isopropanol or 70% ethanol to scrubcuff and cuff hose



Risk of cross-infection due to contamination!

- The outer surface of the machine should be cleaned with an appropriate cleaning agent after each treatment.
- In case of surface contamination with blood, disinfect and clean properly.
- In case of contamination of pressure sensor connectors with blood, disinfect and clean properly.



Don' t let liquid into cuff and cuff hose.

While cleaning, do not use thinner, benzene etc. Otherwise it may cause the machine deformation, metamorphism and coating spalling etc.

## 4.2 Check before treatment

Before the treatment, please check as follows:

### 4.2.1 Power supply

- The power plug should insert into the regular and special socket.
- Do not use AC socket and adapter without grounding protection.
- Do not damage the power line, cable and connector etc.



Do not use AC socket and wiring board without grounding safely.  
When the grounding is not perfect, there will be a risk of electric shock.

### 4.2.2 Dialysate

Before the treatment, it is needed to check whether the dialysate is satisfied. After the conductivity is stable, please sample form the dialysate sampling port to check followings:

- Please use test paper or reagent to make sure there is no residual disinfectant and acid.
- Besides, while using sodium hypochlorite as disinfectant, use DPD (diethylp-phenylenediamine) to determine whether the fluid residue is left, and use ph test paper to determine whether the acid is left.
- Please check the concentration, PH, and osmotic pressure of dialysate whether satisfy prescribed requirements.
- Please check whether the dialysate formula setting in system setting meets the actual used concentration formula.



To avoid hurting patients, before HD, please make sure the confirmation after the conductivity is stable.

### 4.2.3 Pressure Monitor tubes

When the air filter is wetted by normal saline or blood, please change another one.



When the air filter is polluted, please disinfect before using to avoid cross infection between patients due to blood contamination.

## 4.2.4 Leakage



Please check whether there is leakage in the filter or under the machine bottom. If there is, the net fluid removal error of leakage volume may be happened.

## 4.2.5 Other checks

Check there is no abnormal tone, abnormal heat and nasty smell etc.

Check the inlet tube, outlet tube, fluid and dialyser tube are without bending, damage and slack.

Check the screen can show proper pressure, concentration and temperature etc.

## 4.3 Check during treatment

### 4.3.1 Dialysate pressure and TMP

Definition:

$$\text{TMP} = (\text{PBI} + \text{PBO}) / 2 - \text{PDO} + \text{Offset}$$

TMP = transmembrane pressure

PBI = blood pressure on the inlet side of the dialyser

PBO = blood pressure on the outlet side of the dialyser

PDO = dialysate pressure on the outlet side of the dialyser

Offset = Correction of flow-dependent pressure drops

1) Compared with the values shown on daily, the values of dialysate pressure and TMP should be normal.

The dialyser for the patients, on the condition of net fluid removal, if the values of dialysate pressure and TMP are different from the values on daily, the net fluid removal control system may be broken.

2) The values of dialysate pressure and TMP should not be changed dramatically.

If they are changed dramatically, the water circuit control system may be broken.



While using the dialyser of which the UFR is high, please pay special attention to the above matters.

### 4.3.2 Detection of the dialysate ion concentration

Compared with the values on daily operation, the values of the concentration should be normal.



When the values of the concentration changed, please sample to dialysate after discontinued the treatment, and check the values of the concentration by biochemical analysis.

### 4.3.3 Other observations

While treatment, please observe patients' state unceasingly. If there is something wrong, OFF the treatment immediately, then treat according to doctor' s instruction. There should be no leakage, no abnormal tone, no abnormal heat and no nasty smell etc.

## 4.4 Check after treatment

- Please record the treatment data. This is to prevent data from being reset (display is eliminated).
- There should be no leakage, no abnormal tone, no abnormal heat and no nasty smell etc.
- After the treatment, please ensure the dialyser connectors are connected well while rinsing and disinfection

# 5 Treatment preparation

## 5.1 Preparation of machine before treatment

### ➤ Preparation condition

- The machine must be connected with dialysate supply tube, and the inlet valve must be open.
- The power line must have been connected with the power socket.
- The drain pipe must be inserted into the outlet port.
- The water for dialysis must be satisfied.
- The water supply pressure should meet the requirements; the regulator outlet pressure should meet the requirements of (0.1-0.11) Mpa.
- The patients have not been connected with blood tube and dialyser.
- Prepare the consumables for patients well.
- Prepare the consumables for concentrates and bicart etc.
- If the patient has IC card, please insert it into the slot.



Before treatment, especially after 48 hours of inactivity, please disinfect the equipment, otherwise the patient may be infected due to the growth of bacteria.



The inlet tube and the waste tube can not be folded and there should not be leakage. otherwise the machine can not be operated normally.



For acetate dialysis, please confirm that use acetate concentration only.

If misuse the fluid, it may cause harm to patients.



The A/B aspiration must be put into A/B bucket. Or else it may bring danger.



Before finishing the treatment, please insert concentration connector into the container.

- Concentration supply
  - Prepare concentration well.
  - Rotate A (red), B (blue) aspirations which are connected with the rinsing port a little, then remove.
  - Insert A (red), B (blue) aspiration into A/B cover, then screw.
  - Put down the cover of the rinsing port on the machine to prevent the rubbish
  
- The bicarbonate dialysis
  - To avoid mistaking concentration, it is needed to identify containers by different colors, such as put A fluid into red, B into blue.
  - Use standard dialysis powder to configure A, B dialysate (Abbreviation A, B fluid) according to its instruction. Then put them into A, B containers. Put A, B containers which are full of A fluid and B fluid on the base. A container is on the left, and B container is on the right.



Please insert enough concentration into the container.

To prevent concentration going bad, the opened concentration can not be kept over 24 hours.

- The selection and setting of the concentration formula
  - This can be launched under the cooperation with after-sale supporter.
  
- The procedure of installation bicart
  - Pressing the button of bicart device upper fixed part, raising this part as much as possible.
  - Putting bicart in the bracket and inserting into the inlet & outlet tube to the fixed parts channel.
  - Push down the fixed parts and the button will pop-up, then perforated bicarbonate cartridge and fixed on bicart bracket.

- Change the bicarbonate cartridge during treatment.
  - Press "Bypass" , the equipment turn into bypass state.
  - Press "Bicart Empty" , then the bicarbonate cartridge will be drained automatically.
  - Remove the drained cartridge.
  - Install another bicarbonate cartridge.
  - Press "Bicart Charge" to fill in bicarbonate cartridge.
  - Press "Run" to continue treatment.



When the machine on the mode of standby, HD,HDF, HF, fill in the fluid to Bicart or Bicart drain, press the "bypass" first, in order to ensure treatment safety.

## 5.2 Panel indicator and keys

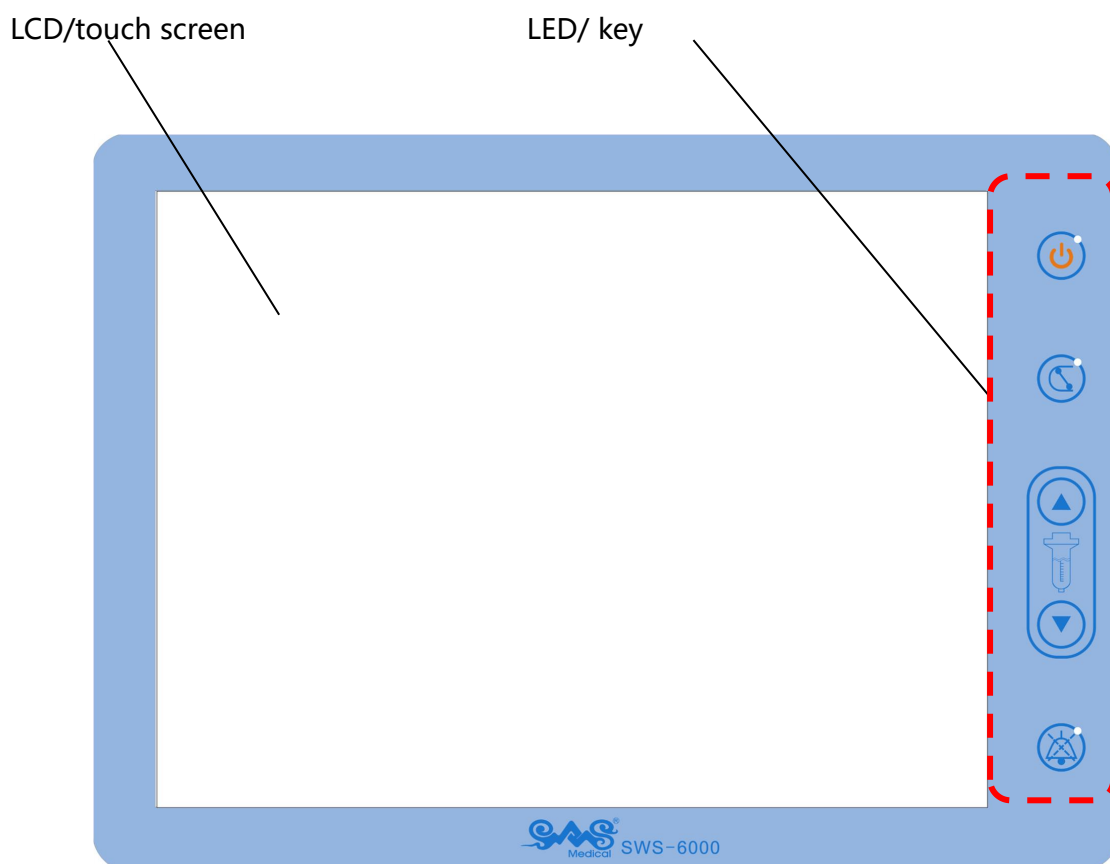

Pic. 5-1 The interface

The interface of the machine is like pic. 5-1 shows. It is composed with two parts: LED /key mainly provide the functions that ON the machine and quick operation keys etc; LCD /touch screen provides the main parameters and state information while operating machine, and does treatment and maintains equipment.





Please check the contents of the screen first, and then operate with ON/OFF key and icons.

Besides, please do not operate with two or more than two ON/OFF keys, icons. It may cause wrong actions.



## 5.2.1 LED indicator light



Table 5-1 LED indicator light

No.	Examples	Name	Action	Introductions
1		Source indicate	Long bright Flash Off	Green long bright, machine is turned on Green Flash, machine standby(Machine is not turned on) Off,machine do not connect the city electricity
2		Blood pump ON/OFF indicate	Light/gray	Light,the blood pump is open and is on the working status. Gray, the blood pump is closed.
3		Mute ON/OFF indicate	Light/gray	Light, the mute is working. Gray, the mute is not working. No matter whether the mute is ON or OFF, the mute will sound when alarm triggered. After one minute' s mute working, the mute will be closed forcibly by machine and the acoustooptical alarm will open.

## 5.2.2 Keys

Table 5-2 Key function

No.	Example	Name	Introductions
1		Power switch	On the OFF state, hold press for 2~3s to start machine. On the ON state, hold press more than 5s to close machine forcibly. This key can not control automatically start or close machine
2		Blood pump "ON/OFF" Key	ON/OFF blood operation
3		Fluid level "+" Key	To "up" The fluid level of the bubble catcher. Press to "up" , loosen to maintain.

4		Fluid level “—” Key	To “down” The fluid level of the bubble catcher. Press to “down” , loosen to maintain.
5		“ Mute” Key	ON/OFF alarm sound

### 5.2.3 Screen layout

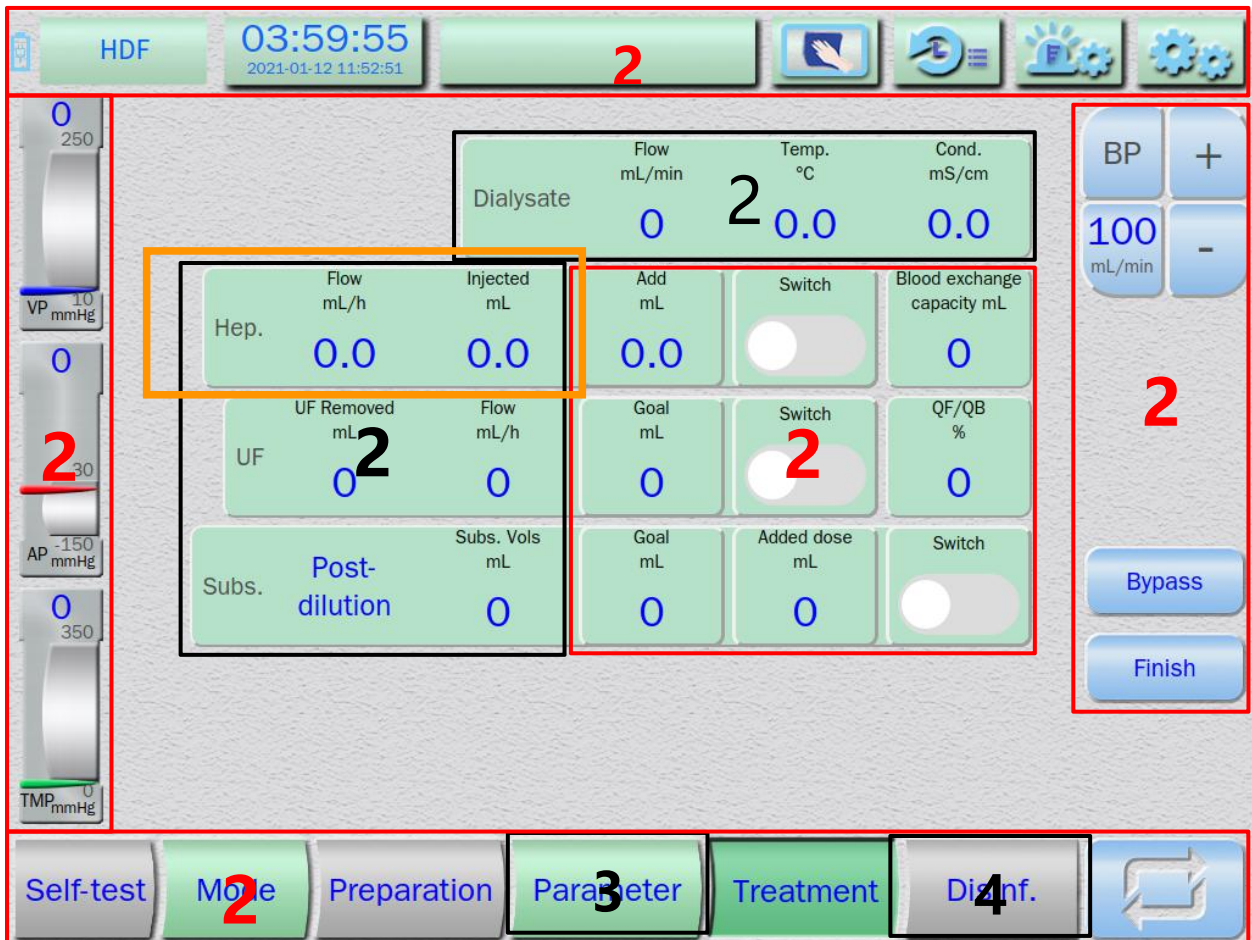

Pic. 5-2 The screen layout



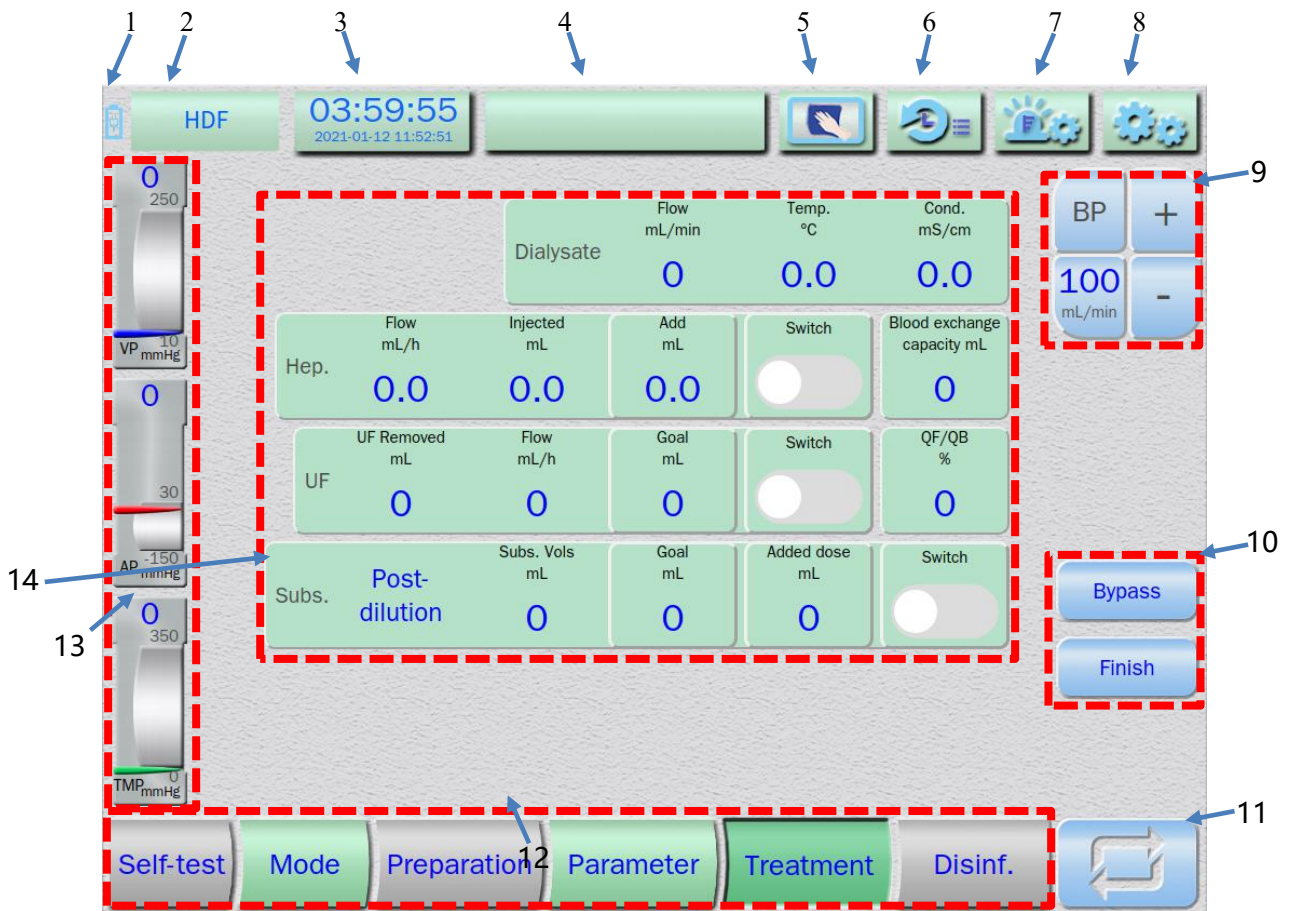

- Area 1 is not a button. It is an area for displaying information.
- Area 2 is a independent button,click it will start some operation.
- Area 3, the button with green shading ( “3” ) indicates that the button is available, click it will start some operation.
- Area 4, the grey button can nott be clicked.

### 5.2.4 Screen keys





Pic. 5-3 instruction layout

Table 5-3 The instruction table of the functions of the screen layout

No.	Name	Instructions
1	Battery Status	 —Power supply  — Battery supply  —Charging  — Battery error
2	Work mode	Show work mode of the current interface.
3	Process rest time/ Date /Alarm	Show the rest time of current process-treatment,prepare etc Show the current system date and system time Click to set the alarm
4	Alarm information	After click ,show all the alarm information
5	Lock the screen	When disinfect the screen,click this button to lock screen for 10 seconds
6	Real-time information	Show the parameter of running status
7	Alarm set	Show the history alarm information Set the alarm limit

8	Parameter set	Set parameter
9	Blood pump control	Turn on or turn off blood pump,set blood pump speed
10	Process control	Show prime,lead blood,re-infuse,pause,dialyser charge/drain, bicart charge/drain
11	Running	When show the alarm, confirm it , and then click the button to recovery
12	Process operate menu	Show current treatment process
13	Venous ,arterial control	Show the real-time pressure, alarm limit and dynamic tracking Alarm limit
14	Main window	Show all control of current operate Show the alarm and note during operate

### 5.3 Starting the system

- Start the system power
  - Ensure the switch on the rear cover is in " I " station
  - Power key  green light flash means the city electricity is normal.
  - Hold pressing the power key  for 2~3s to start the machine.
  - When the LED is green, the machine is started.
- The guidance of the system
  - When the system is on the state of guidance, the LOGO information is shown on the screen first.
  - When the system is guided, the indicator light of IV pole will be green .
  - System will send out a prompt tone.



Check whether the alarm LED is light and whether there is a warning tone.

- Power on self test
  - For a few seconds, the progress bar and mode selection icon will appear on the screen.
  - In the process of the progress indicator, the warning LED (green) is always light to test RAM, module communication etc. Refer to the Pic. 5-4

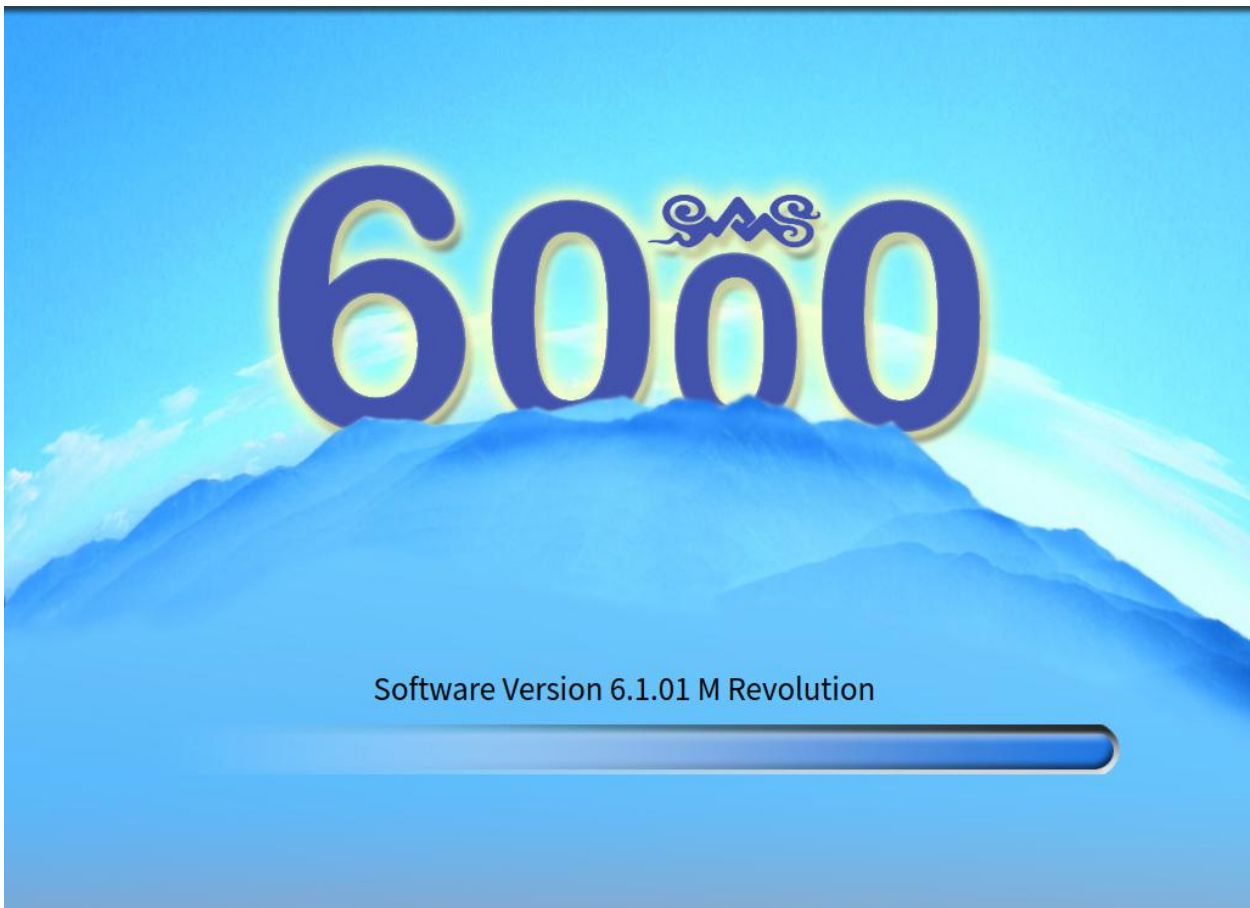





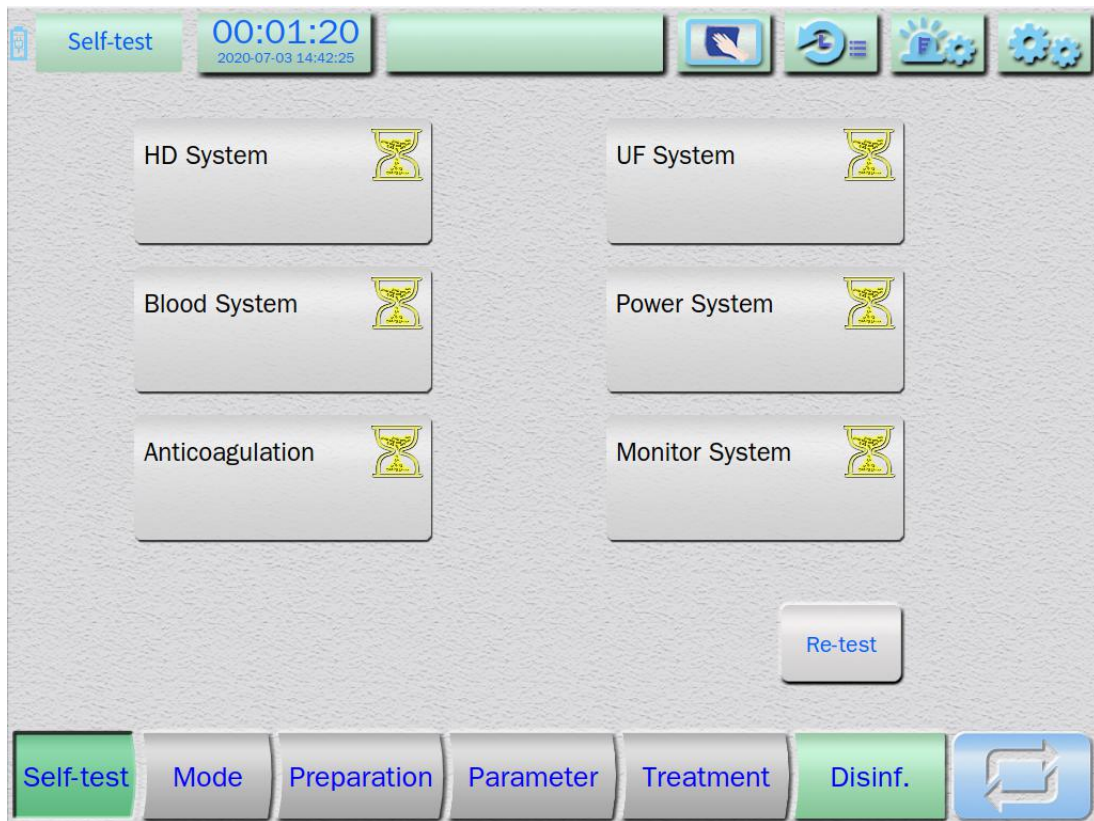

Pic. 5-4 The system guidance window

## 5.4 Self test

The **【self test】** Contains: The self test for parts and functions of the HD system, UF system, Blood system ,Power system , Anticoagulation system and Monitor system etc. Please refer to the Pic.5-5.



Pic. 5-5 The self-test window

- Passed item"  "
- Disconnection or other fault "  "
- The item without self test or being self test"  "
- When the self-test finished, it will turn to interface of  "mode" automatically, mode selection and tube connection please refer to next chapter.
- If something wrong to the self-test or have already finished the self-test,the medical worker can click the  "re self-test" in the bottom right corner of the main interface,then the self-test will be done again.
- During the self-test, there is no any items pass the test, the area of "alarm" will show the information.
- If re self-test can' t be passed, please record the steps and data, and then contact engineer.
- Long-press  , the set interface of "system parameters" will pop out,In the "system parameter" interface,choose "YES" of "skip self-test" ,click the left bottom button "Mode" to skip self-test, but the mode which didn' t pass the self-test will not be

operated, So normally ,the machine can not be operated .

☆For the maintenance, Please refer to 【chapter 9.2】 ,or inform the engineer.



Before treatment, safely passing self-test will reduce safety risk to minimum.

As force to quit self-test, and continue to treatment, it will lead to safety risk.

During the self-test, do not connect patients; otherwise it will bring the safety risk.

## 5.5 Mode selection

After the self-test, the system will turn into “mode” interface .As pics5-6 :

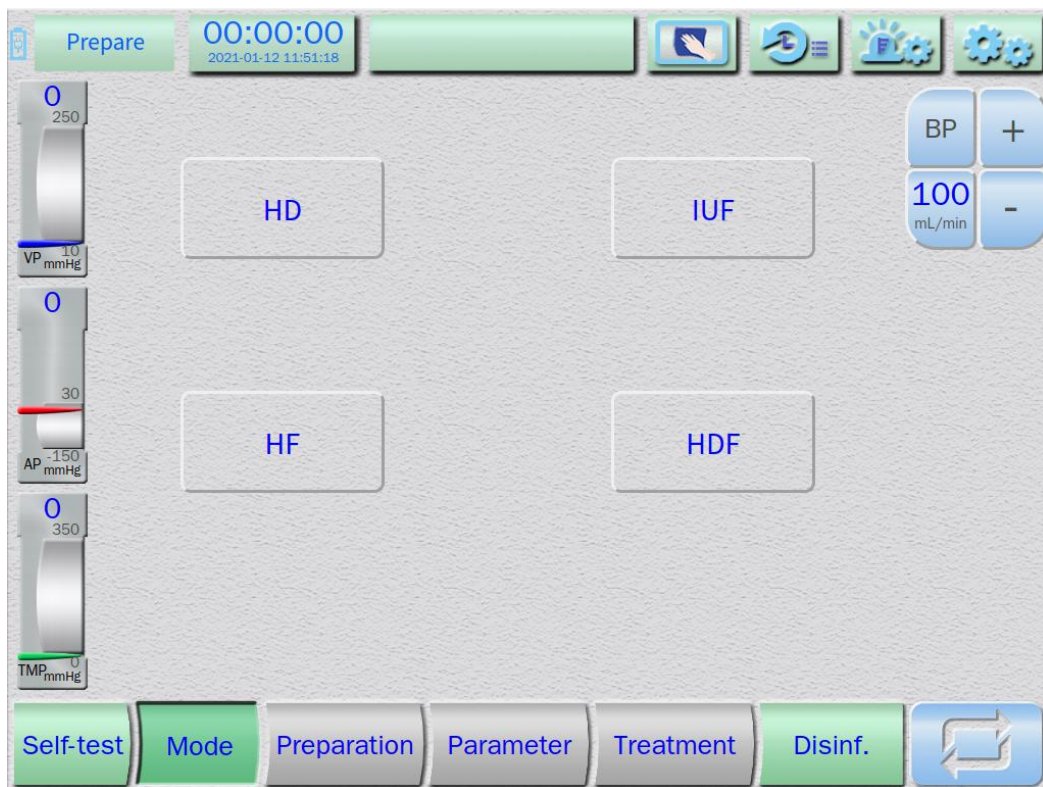

Pic. 5-6 Mode selection window

➤ This is interface can select different treatment mode, as pic. 5-6 shows. Different dialysis machines have different mode.

### 5.5.1 Preparation of consumables

Table 5-4 the consumable and its quantity for different treatment mode

Name	Treatment mode				Remark
	HD	HF	HDF	IUF	

Dialyser	1				
Filter		1	1		
Blood circuit	1	1	1	1	Match for different treatment mode
Substitution circuit		1	1		
ETRF	1	2	2		In HD, this one can be canceled.

**Note:** In this table, when there is number, it means quantity;

## 5.5.2 Dialyser installation

### ➤ Install dialyser

- Confirm dialyser packed well and the model is correct; about choosing dialyser, please refer to chapter 1.9. Pry the dialyser clamp (remove is the same) like 5-7

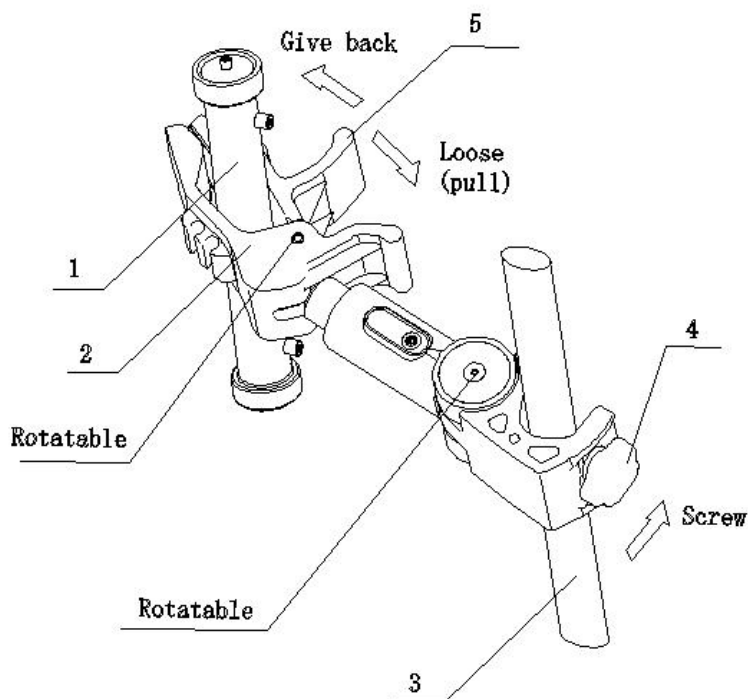

Pic. 5-7 the installation of the dialyser

- 1—dialyser    2—movable clamp  
3—brake    4— knob    5— fixed clamp



The dialyser coupling must be connected with dialyser tightly. There should not be water leakage and air leakage, or else it may impact patients' normal treatment.

### 5.5.3 Blood circuit installation



Please frequently notice the connection of the blood circuit is correct and reliable.

When the connection of the blood circuit is not correct, it may cause serious danger to patients.



Any narrow passages in the blood tubing may cause haemolysis, and this hazardous situation may not be detected by the protective systems.

Check to ensure that no line is kinked.

The picture of the installation of the extracorporeal blood circuit line (refer to Pic. 5-8)

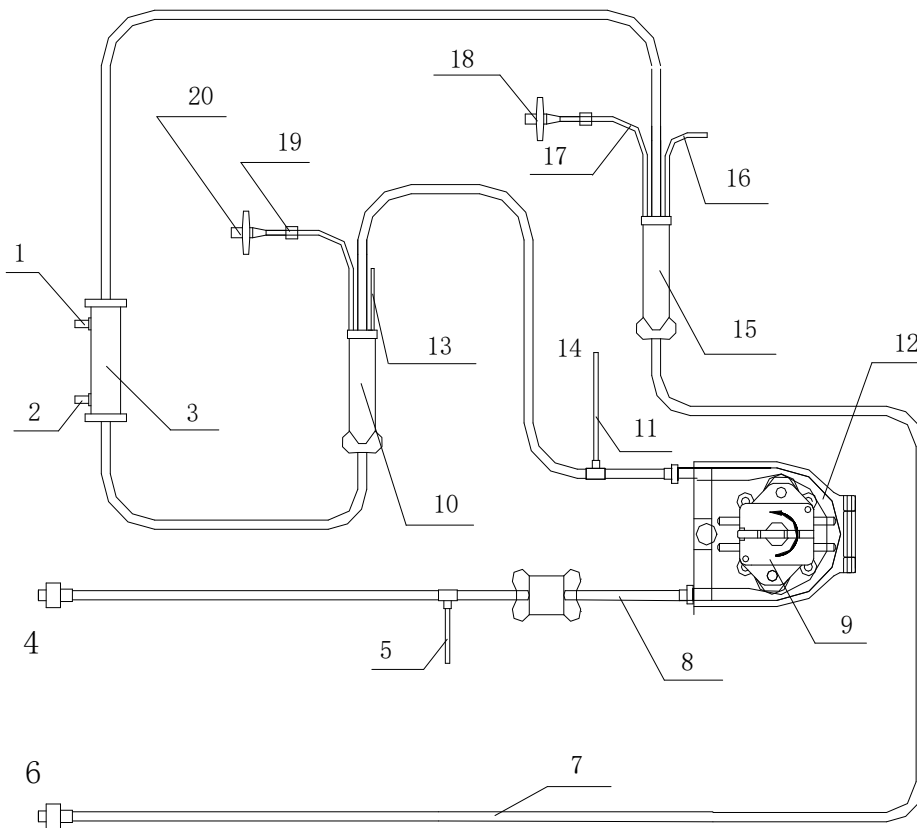

Pic. 5-8 The connection of the extracorporeal blood circuit line

- |                             |                                    |
|-----------------------------|------------------------------------|
| 1—Inlet                     | 2—Outlet                           |
| 3—Dialyser                  | 4—Connect arterial puncture needle |
| 5—Side arterial transfusion | 6—Connect venous puncture needle   |

- |                          |                                      |
|--------------------------|--------------------------------------|
| 7—Blood line             | 8—Arterial line                      |
| 9—Pump roller            | 10—Arterial bubble catcher           |
| 11—Heparin tube          | 12—Pump tube                         |
| 13—Arterial degas tube   | 14—Connect syringe                   |
| 15—Venous bubble catcher | 16—Connect substitution tube when HF |
| 17—VP detector           | 18—Sensor protective                 |
| 19—AP detector           | 20—Sensor protective                 |

➤ Installation of the arterial blood circuit

- The installation procedure of the blood circulation tubes by hand:
- Ensure the blood pump switch is not light.
- Open the blood pump cover.



Please pay attention to the direction of the inlet and outlet port when install the tubes to ensure the direction of arterial tube and inlet is same.

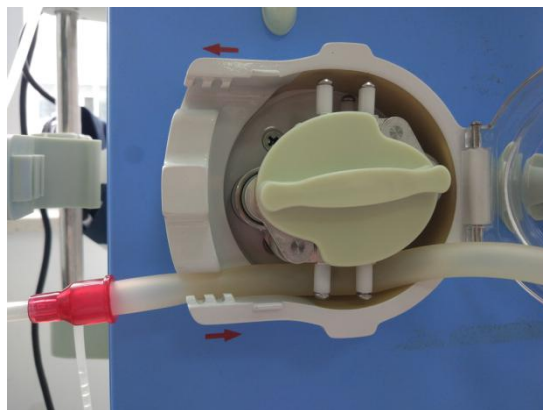

Pic. 5-9 Enclose the pump tube

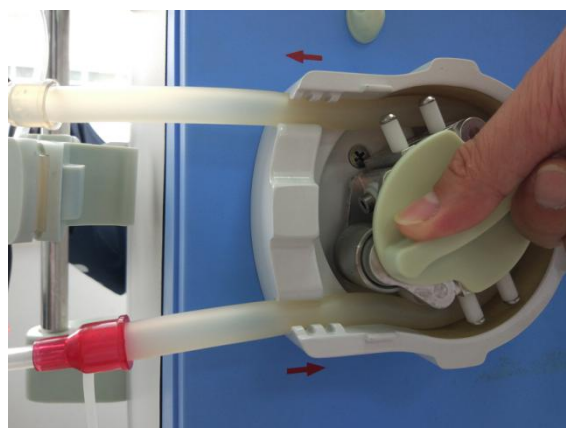

Pic. 5-10 Put pump tube into the place

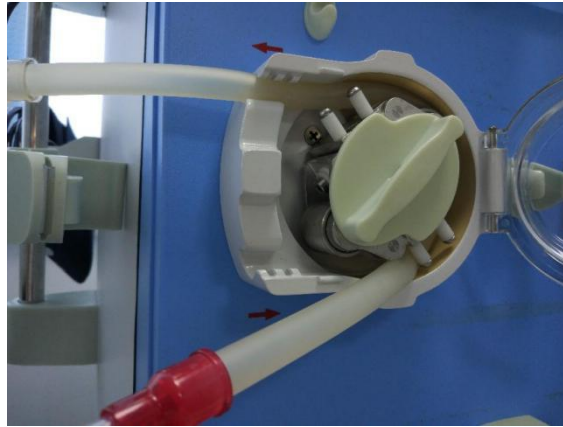

Pic. 5-11 Take out the pump tube

- The installation of the arterial pot and venous pot
  - Use hands to push in arterial pot (or venous pot) from top to bottom.
  - Push into the middle of the arterial pot (or venous pot)
  - While removing, the procedure is opposite

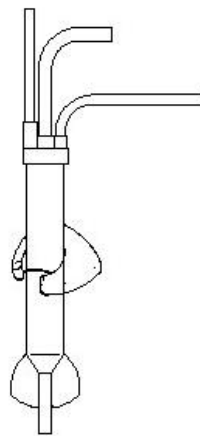

Pic. 5-12 the installation of the arterial pot and venous pot

- The tubing installation of the air detector (and the block clamp)
  - Press the lockpin to open the cover
  - Put the detect tube into the tube seat of the blood leak sensor
  - Press the lockpin to close the cover and lock the tube

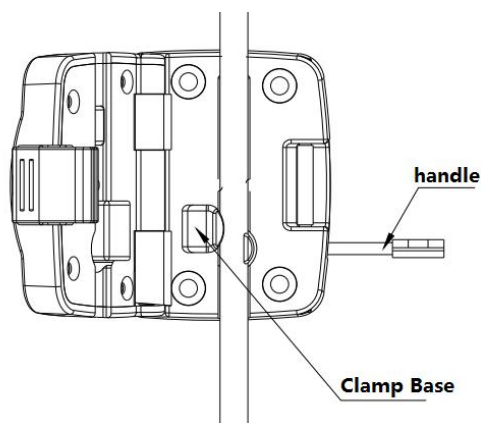

Pic. 5-13 the tubing installation of the air detector (and the block clamp)



If the installation is wrong or the tube is too dirty, it may cause false alarm.

Improper functioning of an ultrasonic air detector may be caused by a coagulum or the application of ultrasound gel.



During the treatment, please keep the tube in the block clamp.

- The installation of the the sensor cover

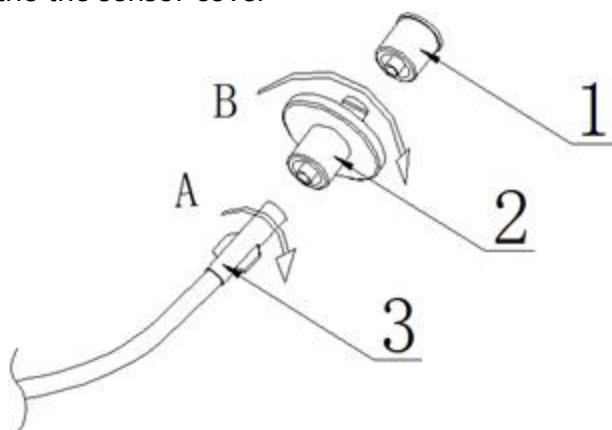

Pic. 5-14 the installation of the arterial or venous detect tube

1. Venous pressure connector
2. Sensor protective cover
3. Venous pressure detecting tube



To avoid cross infection, the sensor cover can be used only for once. After using, abandon it.

### 5.5.4 Installation of heparin syringe

- The installation of the heparin syringe
  - Insert heparin solution into 10, 20, 30 or 50 ml syringe.
  - Open the clamp, put the heparin syringe into the needle seat.
  - Contact the end of the syringe piston with the push plate, then back the plate.
  - Connect the front of the syringe with the heparin tube.

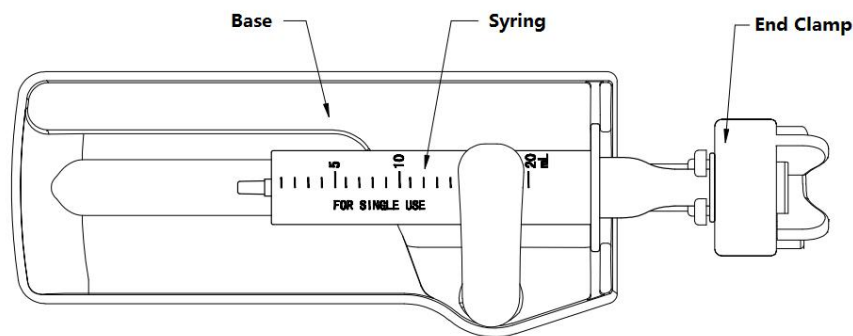

Pic. 5-15 The installation of the heparin syringe

### 5.5.5 Installation of substitution tube (if any)

- The installation of the substitution tube
  - The substitution pump switch is OFF
  - Open the substitution pump cover
  - Insert the starts of the pump tube into the entrance of the slot (red tube), and ensure that the line is in the locator.
  - Turn the roller according to the direction of the red arrow; insert the tube as soon as turning the roller.
  - Close the substitution pump cover. The substitution pump will not rotate when it is open.
  
- The connection of the substitution tube
  - Connect the inlet point of substitution tube to the substitution connector on the machine; connect the outlet point of tube to arterial pot or venous pot.

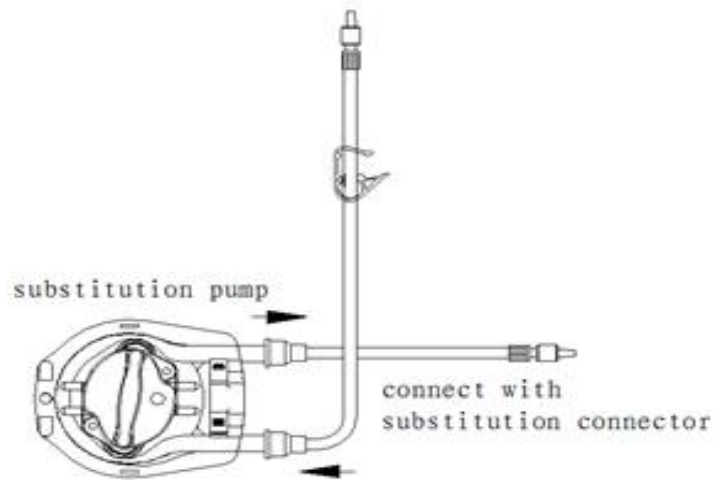

Pic. 5-16 The installation of the substitution tube



Before connecting the substitution tube, it is needed to disinfect to substitution port, or else the bacteria may enter the body to infect patients.

## 5.6 Preparation

“Preparation” , the medical staff can prime blood lines and dialyser in this mode, the interface is as pic.5-17

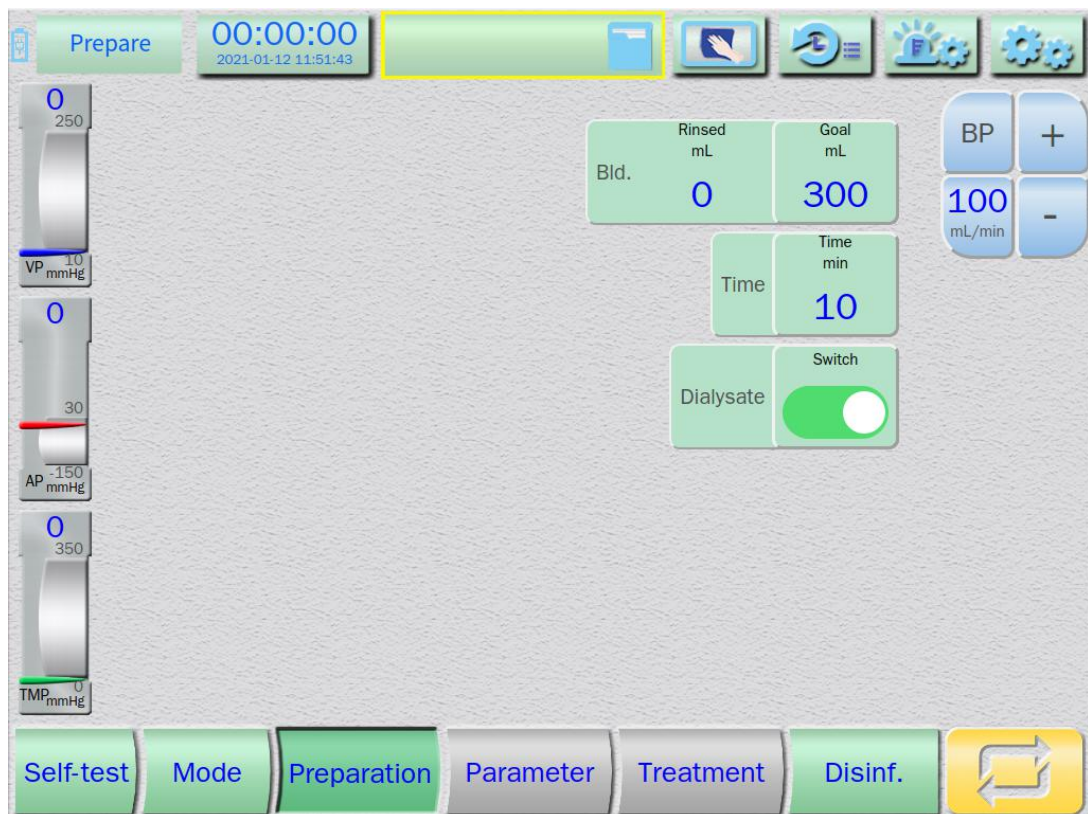

Pic. 5-17 Preparation mode windows

## 5.6.1 Blood circuit priming

Prime the blood lines by saline. Set the amount of saline, blood speed (system default), start the blood pump, let the saline full in the blood lines. (Now, machine is mixing fluid normally)

The details are as following:

Steps as follows:

The prime procedure of the blood circulate tube by hands

➤ The prime to arterial blood circuit

The prime procedure of the blood circulate tube by hands

- Connect the arterial transfusion with physiological saline bottle (bag).
- Clean the physiological saline tubes and connectors of the arterial blood circuit.
- Open the tube of the arterial pot to degas, after finishing degas, close the side tube.
- After cleaning, clamp the tube next to the arterial blood circuit connector.
- Open the blood pump, and adjust the flow.
- Clean until connecting dialyser.
- The level in the arterial pot should reach to 1/3.
- Close the blood pump by hand.
- Clamp the connector of the arterial blood circuit and dialyser to connect dialyser.

➤ The prime to venous blood circuit

The prime procedure of the blood circulate tube by hands

- Connect venous blood circuit with dialyser; remove the clamp clamped in the arterial blood circuit and the dialyser connector.
- Open the blood pump and adjust the flow.
- Flow the physiological saline to clean the venous blood circuit until system connector.
- Open the tube of the venous pot to degas. Close the side tube after degas.
- The level in the venous pot should reach to 2/3.
- After cleaning, close the blood pump by hand.
- Clamp the connector of the venous blood circuit and dialyser.



- If you want to exchange physiological saline bottle (bag), please close the blood pump first. After exchanging, restart the blood pump.
- If you need to recirculate, connect arterial and venous blood tube, and then restart the blood pump.

- The prime of the substitution circuit

The prime procedure of the substitution circuit by hands

- Connect inlet port of substitution tube with physiological saline.
- Press “sub. Pump” To open the substitution pump, and adjust substitution flow to proper values.
- Degas the air in substitution tube, filter and heat bag to let substitution full the substitution tube.



Before the treatment, check dialysate to meet requirements.

When the concentration is stable, you can take sample to confirm.

Use test paper and reagent to ensure there is no disinfection agent and acid.

Ensure the concentration, PH, and osmotic pressure of dialysate meet the prescribed requirements. Or else it will bring serious danger to patients.

## 5.6.2 Dialysate circuit priming

- Stop the blood pump, Connect the dialyser coupling (the blue and red one) with the outlet port of dialyser, and connect the tubes with inlet port of dialyser
- Touch the “prime” button in the screen, the machine will let the fluid in the dialyser automatically. The nurse need punch the dialyser to degas, and turn on the UF, and rinse the transmenbrane.
- The time of Auto-prime is controlled by system, the system will notice after finish the Auto-prime, and user should be punched and connect patients.
  - If the nurse need to prime by hand, so don' t click the Auto-prime button .After Auto-prime.the nurse can shut down and then prime by hand.



Please connect the A and B fluid which is prepared by Formula ratio requirements with connector!

The operation as follows:

- Dialyser empty
  - Click "pause" button during priming and upward the blood insert port of the dialyser.
  - Connect dialyser connector (red) with the outlet of dialysate
  - Connect dialyser connector (blue) with inlet of the dialysate
  - When the interface show the dialog" Start the prime dialyser or not " ,click the dialog ,and confirm it
  - The time of filling can be set in advance.
  - When the time is up, charging will automatically end.
  - During the charging, if there is alarm, the charging will be stopped.



During the treatment, the machine is connected with patients, do not degas. Or else, it will cause patients over net fluid removal or blood coagulation.



Following conditions can cause UF reversely

- Use high flux dialyser
- The rate of net fluid removal is low
- The pressure difference caused by resistance of the dialysate side tube and blood side tube
- The stickiness of the blood



Before connecting patients and blood circuit, please check followings:

- There is no disinfection and acid in the machine.
- Ensure the concentration, PH, and osmotic pressure of dialysate meet the prescribed requirements.
- There is no air in the dialyser, and the dialyser is filled with dialysate.
- All the treatment conditions, include treatment data are prepared well.

# 6 Treatment

## 6.1 Patient connection to blood circuit

- The connection of patients and blood circuit
  - Connect arterial tube to patient;
  - Click  to start blood pump by hands and adjust flow properly; run the blood pump at rate 100ml/min to reinfusion
  - When the “blood leak sensor” tests blood, the blood pump will automatically stop; and the state column will prompt “connected patients; please take care”
  - Connect venous tube to patients.;
  - Start blood pump by hands and adjust flow properly.;
  - Check the fluid level of 2/3 in the venous pot. .



After “standby” and “prime finish” , you can connect patients to blood tube.



If connect patients to machine under “standby” mode, the set alarm range can not be monitored strictly, so please pay attention.



The air in the blood tube can not enter the human body. The air may cause air embolism and endanger patients’ life.



Because of counter current flow in the dialyser, backfiltration of dialysis fluid takes place in at least one part of the dialyser even in low-flux dialysers (ultrafiltration coefficient < 10 ml/(h mmHg) ). If high-flux dialysers are used, backfiltration cannot be avoided even by high ultrafiltration rates acceptable for fluid removal from the patient.

Backfiltration may take the hazards from dialysis fluid to blood.

## 6.2 Treatment parameter settings

### 6.2.1 Treatment parameter quick set

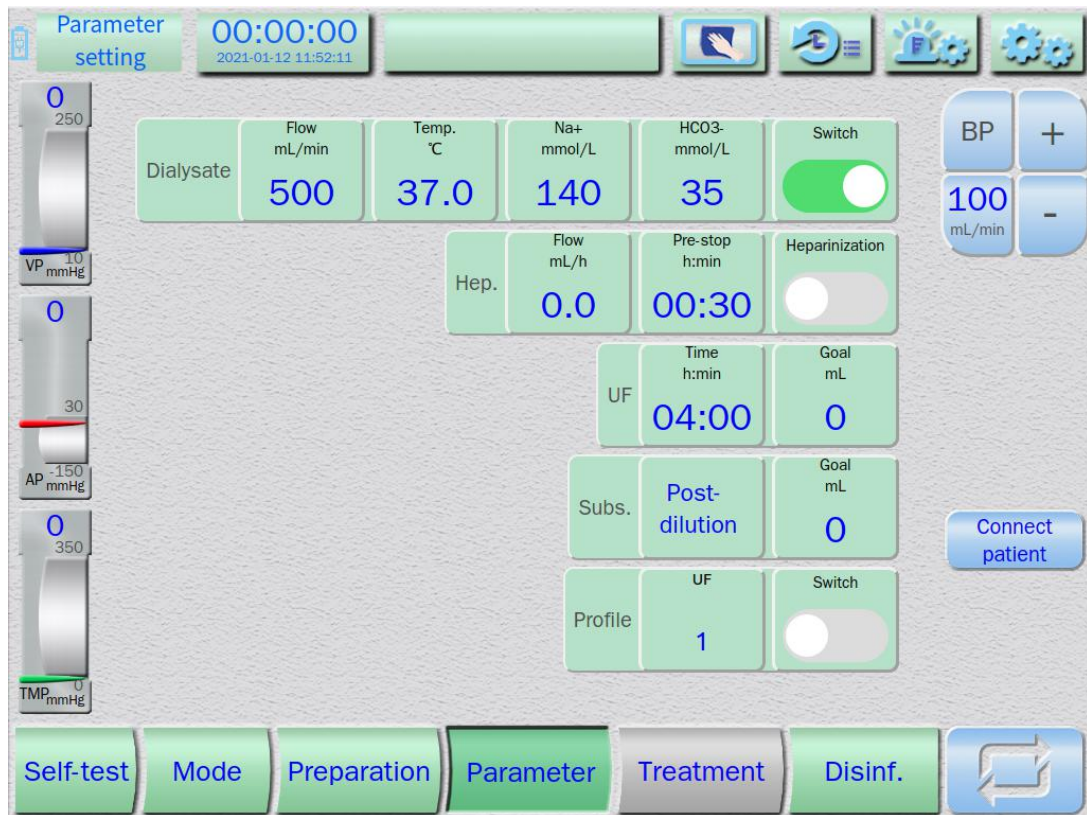

Pic. 6-1 Treatment parameter set interface window

The treatment parameter interface provides the treatment parameter set.

Under the preparation interface or treatment interface, you can set the parameter, Take the dialysate parameter as example, the parameter set, please click the flow as 6-2 pic, and enter the dialysate flow set.

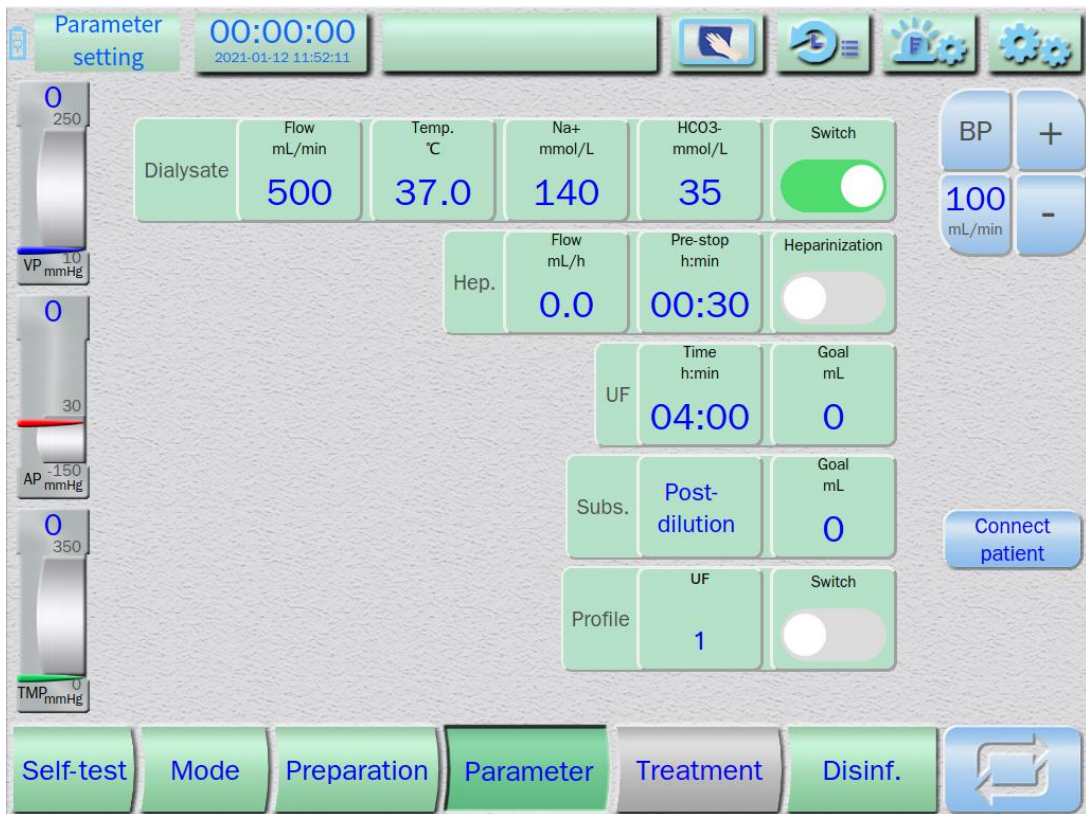

Pic. 6-2 Dialysate parameter set window

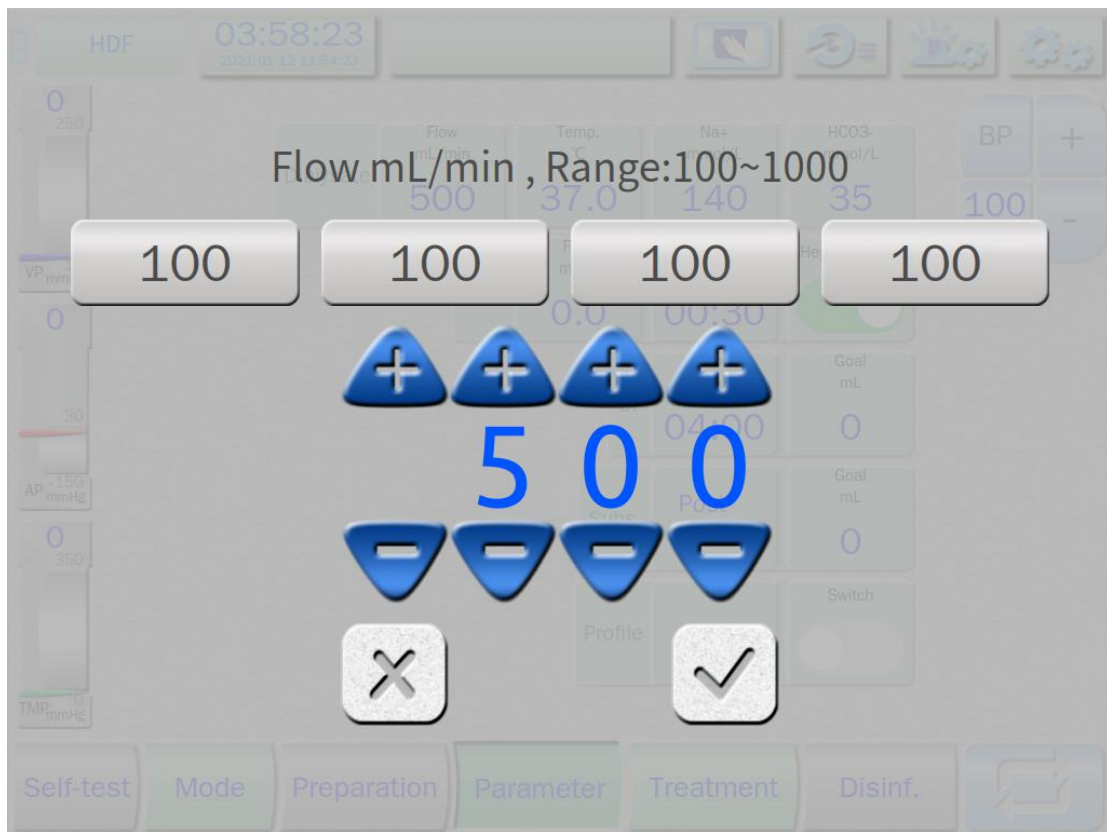

Pic. 6-3 Dialysate flow set steps

The dialysate flow set as pic. 6-3 states, which including three steps.

- Step1:Click flow bottom of the HD item, and will pop out the paramter set .
- Step2:click "+" "-", adjust the parameter , match the expected value , click the "√" confirm the revisions.
- Step 3:after return , check whether the parameter set is valid or not . And then, the parameter set finish.

According the method above set all treatment parameter.

- After set the HD parameter, click the UF parameter to set the UF parameter. Under different set, different type of the machine, the configuration of the content will be different.

## 6.2.2 Alarm quick set

During the treatment parameter set , quick set the alarm limit , the set interface according the the pic. 6-4:

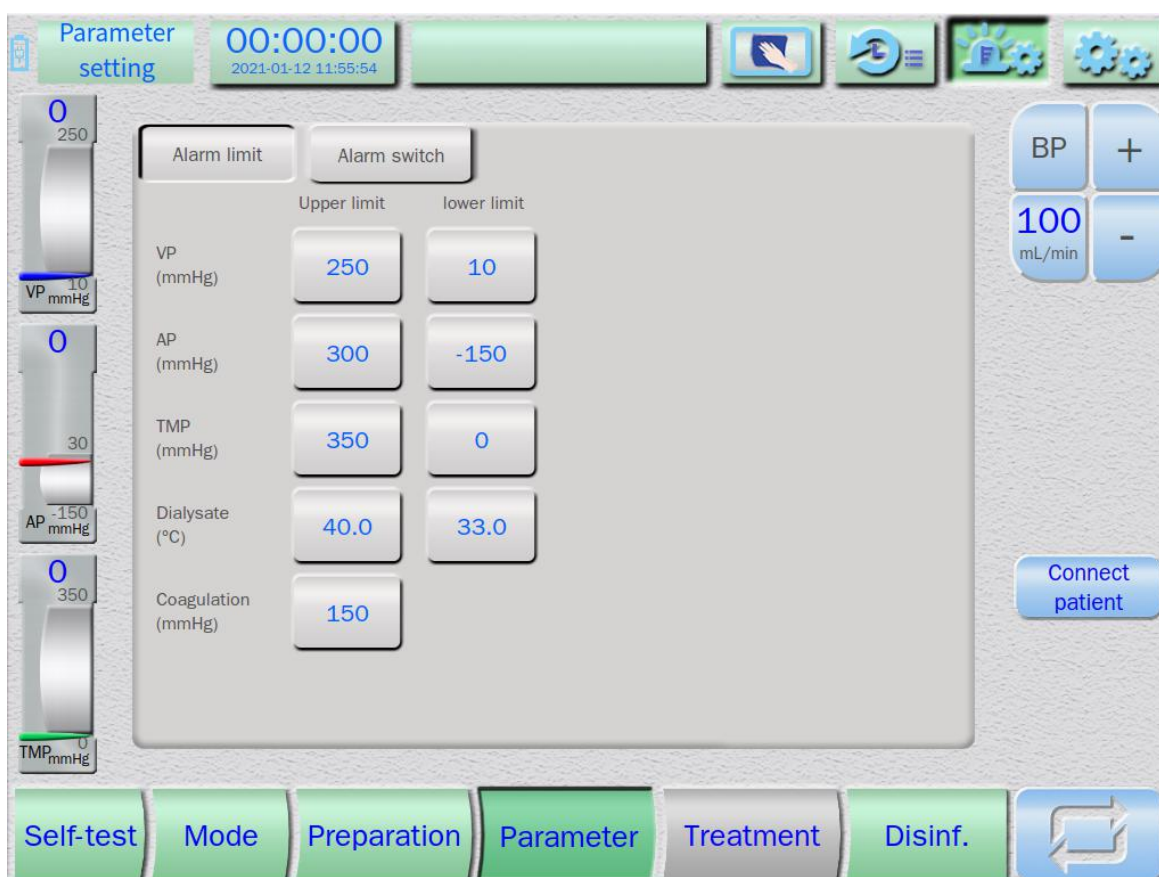

Pic. 6-4 Alarm parameter limit set window

Alarm set please refer to 6-4, three steps.

- Step 1:Click parameter, pop out the alarm limit set window;

- Step 2:click alarm list , switch to the alarm limit set ;
- Step 3:click the alarm set , set the alarm limit.

According to the method above , set all alarm limit parameter.

- Set the vp low limit paramter , click the vp high limit to set the high limit parameter
- Under different setting, different type of machine, the interface and the context will be different.



When finish the treatment or exit the treatment, all data will back to initial data!



When nurse do the treatment, they should confirm the HD parameter, UF parameter, anticoagulation parameter, ensure all treatment without any error.



Different type of machine, different software version, the parameter set may be different.

### 6.2.3 Parameter set

On the top-right corner of the screen, which provide  button:Click the parameter set bottom then will pop up the set window as pic. 6-6 shows , which includes the NA+concentration , dialysate flow , and maximum UF.

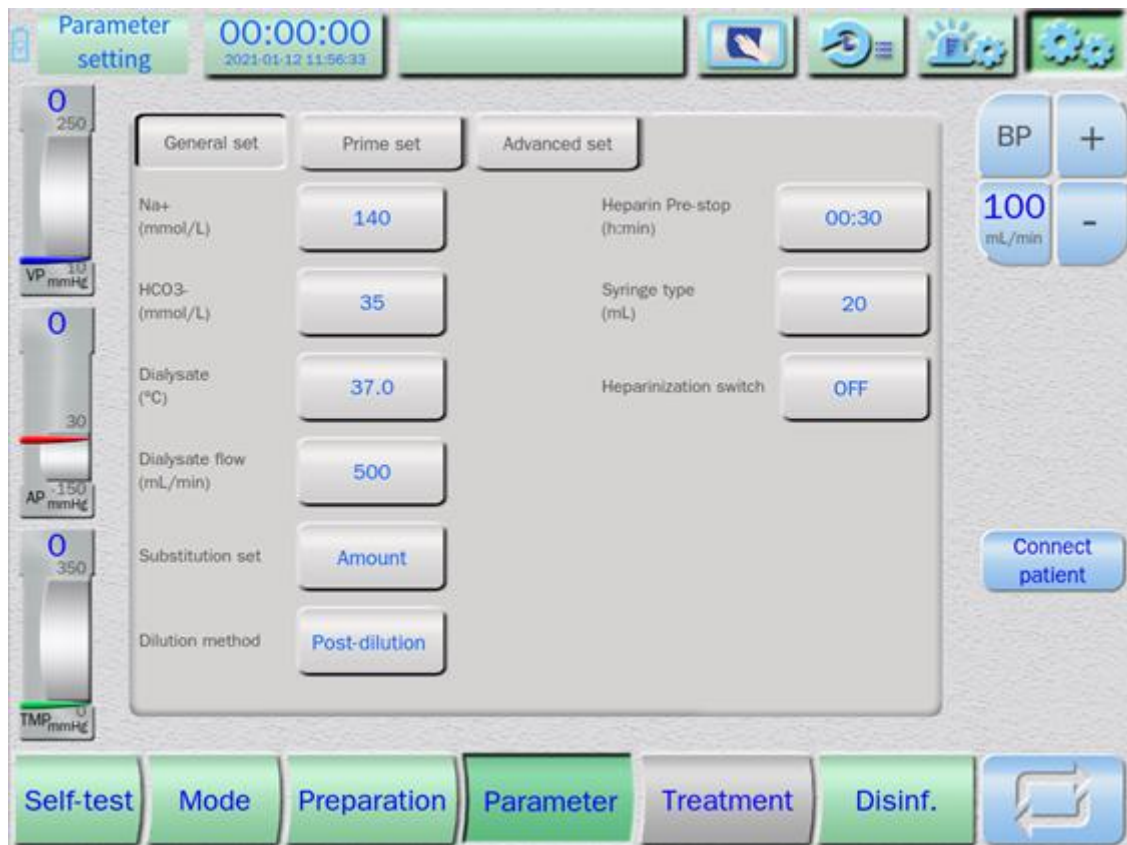

Pic. 6-6 Parameter set window

Click the parameter to revise

- Change the parameter of the interface , which will revise the default set of the machine , when turn on the machine next time , the machine will work according to the current set .
- Click the parameter set bottom, which will exit this interface.
- The parameter set includes the parameter, prime, Kt/V.



Not suggest the nurse to enter this interface to set.



Different machine type have different interface, which will have little varies.

## 6.2.4 Alarm parameter set

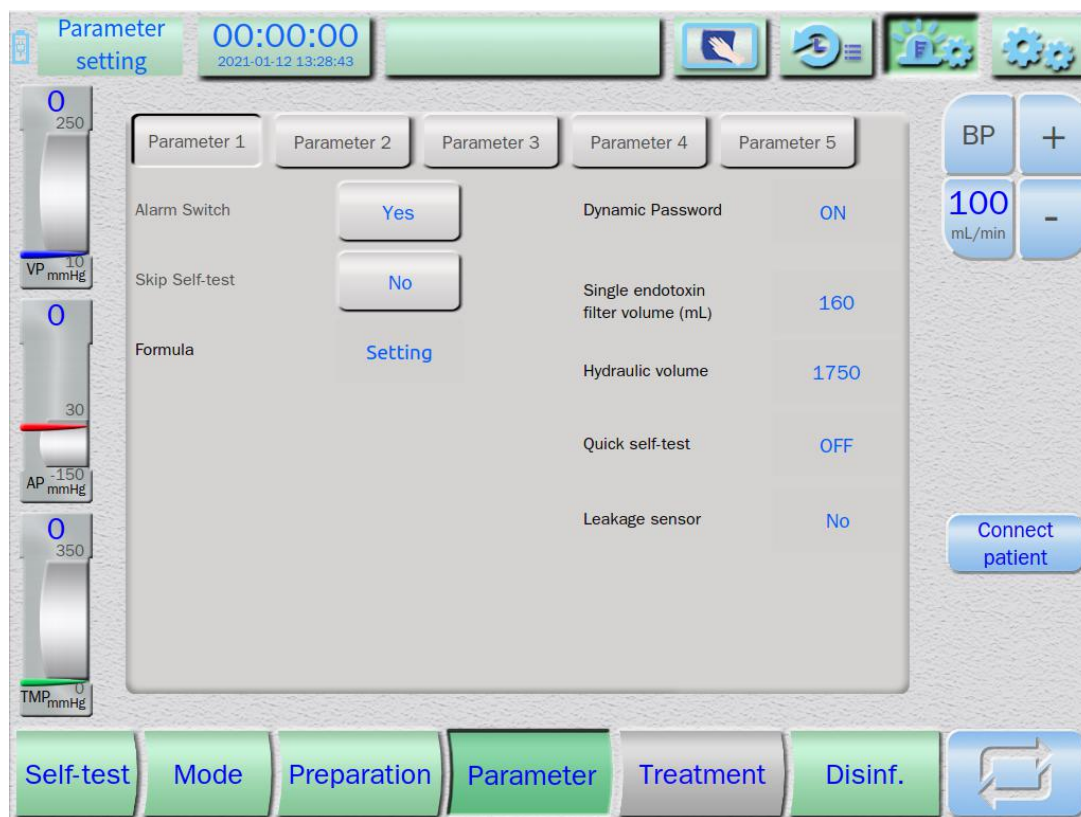
Nurse should follow the Operation Flow menu to finish the whole treatment parameter and monitor parameter, and also provide the alarm parameter set, the steps as pic 6-7 shows.



Pic. 6-7 Alarm parameter switch window

- Press the system parameter set of the mark "1" for longtime as pic. 6-7
- Input the correct password ( the password should consult to our technician ), enter the setting interface, set the alarm switch to yes
- Then click the mark "1" system parameter set as pic. 6-7. Back to the initial set interface
- Click the mark "1" system parameter set bottom as pic. 6-7, open the alarm parameter set.
- Click the the mark "2" of the alarm switch , switch to the alarm switch parameter set
- Click the mark "3" dialysate temperature in 6-8 , change  OFF or  ON
- The other monitor parameter set as pic. 6-8

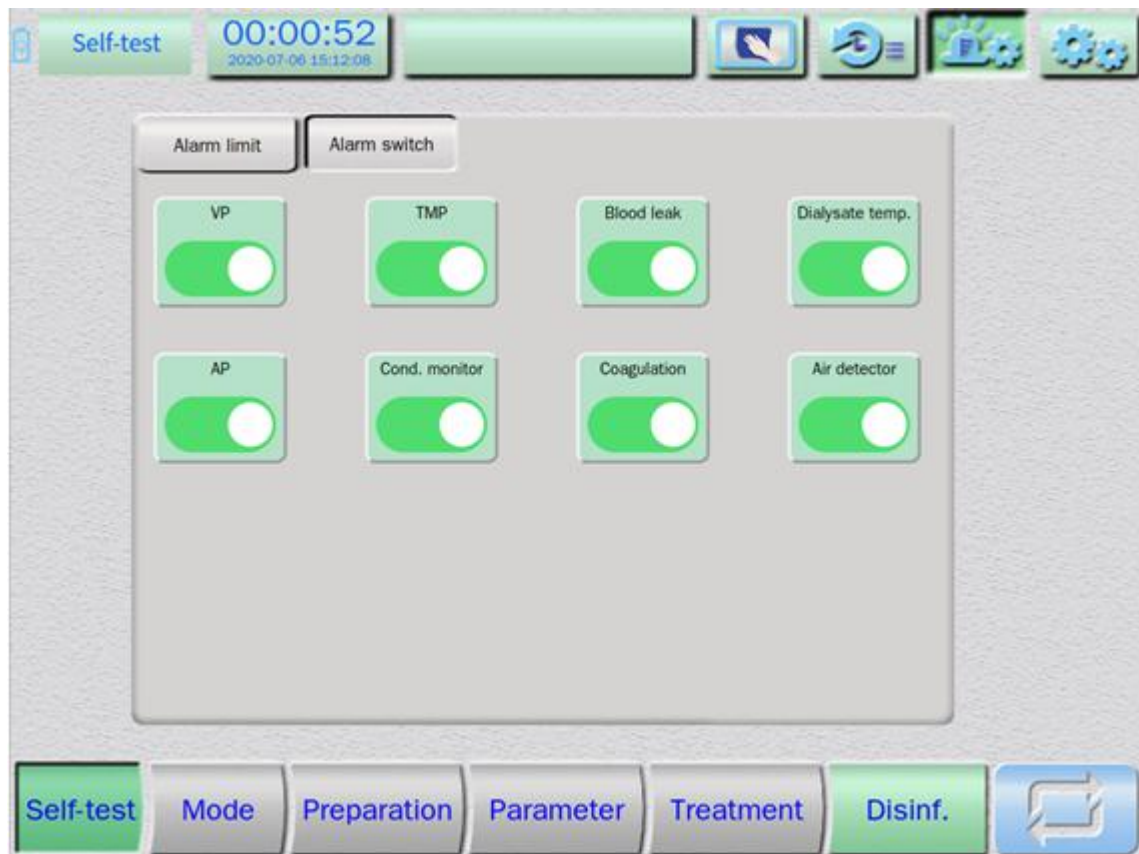

Pic. 6-8 Alarm switch setting

The override time for all protective systems is 1min.



Generally we do not suggest the operator to enter this interface to set.

Different type, different setting, the interface and the context are different.

## 6.3 Beginning treatment

After parameter set, click the treatment bottom, it will pop out confirm the treatment parameter, click yes to enter the treatment.

### 6.3.1 Treatment interface



Pic. 6-9 Treatment window

### 6.3.2 Interface Introduction

- When begin the treatment, before reinfusion, selftest, preparation, rinse can not be clicked.
- During the treatment, please click the parameter set and mode, set the treatment parameter.
- The configuration and the color will be different according to the machine outlook and the machine type.

## 6.4 Treatment Process



During treatment, pay attention to the patient's vital signs, such as body temperature, blood pressure etc.



During treatment, please monitor the window and guiding information (alarm etc) of this machine.



If the cannula is broken or slipped out, it will cause blood losing and endanger patients. The monitoring of the machine cannot monitor this condition.

During treatment, it is needed to observe the condition of the tube connection all the time.

Ensure the cannula fixed tightly, and check the tube connection at regular time.



After and during treatment, please check whether the leakage is in the blood circuit, dialyser and dialysate circuit etc.

If treatment is under the leakage, it will cause net fluid removal too much or blood losing.



The blood flow rate, and thus the treatment efficacy, may be reduced when the pre-pump arterial pressure is extremely negative.

### 6.4.1 Heparinized treatment

Heparinized treatment often uses the low molecular heparin, or normal heparin, if low

molecular, it needs the injection by hand, the follows take the normal heparin as introduction.

➤ Heparin syringe installation

- Turn on the heparin switch, or else it may result in blood loss due to blood coagulation.
- Release unlocking lever by pushing it upwards and pull out drive mechanism.
- Lift and turn syringe bracket.
- Insert syringe in such a way that grip plate and push plate engage in the guides.
- Close syringe bracket.

➤ Start heparinized treatment

- Set the syringe type in the parameter set menu  set.
- Set the pre-stop time.
- Turn on the heparin switch.

➤ Heparin bolus

- Heparin bolus is given in case of insufficient anticoagulation.
- Set bolus volume under the treatment interface.

	Rate mL/h	Injected mL	Add mL	Switch
Hep.	0.0	0.0	0.0	



The use of low delivery rates of device-integrated anticoagulation means could lead to delayed and non-continuous delivery due to compliance in the delivery means or output pressure changes in the EXTRACORPOREAL CIRCUIT.



Improper setting of anticoagulation parameters will cause harm to patient, please set the heparin parameters as directed by doctor.



Please contract technician, if more than one anticoagulant solution is used for anticoagulation within one treatment.

## 6.4.2 Set and adjust treatment parameters

### ➤ Modify treatment parameters

When modify the treatment parameter, you can revise the parameter under the treatment interface, or you can click the parameter of the operation flow menu to set the parameter.

**NOTE**

The parameter should be modified according to treatment prescription, if it is necessary, please check with doctors.

Some parameters, such as the adjustment of UF volume, may cause that the treatment can not be finished in the scheduled time.

Please ensure that the operator has checked the adjustment of the parameters. During the treatment, the machine can not distinguish.

**NOTE**

Risk to the patient due to blood pressure drop or cramps!  
Continuous ultrafiltration may result in blood pressure drop or cramps.

- Ensure that ultrafiltration will be stopped in appropriate time.
- During treatment, blood pressure should be monitored regularly with a sphygmomanometer.

### ➤ Adjust the UF parameters

- Parameters related to the UF contain UF volume, UF removed, treatment time and UF rate.
- $UF\ rate = (UF\ volume - UF\ removed) / (treatment\ time - past\ treatment\ time)$ .
- During the treatment, the UF removed and treatment time can not be modified. But the UF volume and the treatment time can be modified; UF rate can be modified, when one parameter of UF goal, UF time has been changed, the two other parameters may also be changed.
- If the treatment time and UF goal is modified, the UF rate will be modified accordingly.
- If it is necessary, users can touch UF volume, UF time etc on the screen to modify UF parameters.

- Blood pump flow adjustment
  - On the right side of the screen there have the blood pump rate adjustment “+” 、 “-” bottom , adjust the blood pump rate , as the right pic. shows.
  - The flow of the blood system can adjust the blood flow.



- Independent clock
  - On the top of the screen, it will display the residual time, which will provide the independent clock, the user can use flexibly. Check the right pic.:
  - The user can click the icon, set the clock and use.



### 6.4.3 Switching treatment mode

- Please install the tube according to the HD, and select the correct dialyser.
- After install the tubes, begin the treatment.
- During the mode switch, the machine can provide the Compatibility mode, such as: HDF-HF-HD-IUF.

### 6.4.4 Temporary interruption or termination of treatment

Under the special situation, for example, the patient want to go to the rest room , the tube leakage , the dialyser membrane broken , which may need to stop the treatment temporarily .

- If do not need reinfusion, stop the treatment only need to click the suspend button, the machine will switch to suspend mode, for example , open the bypass , turn off the UF , stop the substitution , blood flow manually decrease to 100ml/min.
- If need reinfusion, please click the blood infusion which on the right side of the screen, operate as the machine mentioned, reinfusion method please refer to the next chapter treatment finish.

## 6.5 Treatment termination

### 6.5.1 Blood return

When finish the treatment (a residue time is 0) the system will pop out the prompt box, mention “treatment finish, begin reinfusion” the user click to enter the reinfusion mode.if

the patient need to finish treatment in advance, click the reinfusion.



During the blood return, the alarm range can not be monitored strictly. Please pay attention by monitoring venous pressure and air.

- Patients blood return
  - Close the blood pump
  - Take the arterial blood tube down from patients.
  - Connect arterial tube with physiological saline.
  - Start blood pump by hands. Blood pump will operate according to basic flow. You can adjust flow properly.
  - If the “blood leak sensor” Checked there is physiological saline, the blood pump will stop automatically.
  - Start blood pump. When all of the blood return to body, close the blood pump.
  - Take down the venous blood tube from patients.

## 6.6 Post-treatment handling

- Discharge fluid
  - Short connect the arterial and venous connectors and keep both clamps open.
  - Take down the artery and venous pressure tube from AP/VP port.(open the clamp)
  - Turn the dialyser upside down.
  - Click “Drain” .
  - Wait for the draining completion.
  - After the draining, put the dialyser couplings back to machine.



Please discharge after extract the arterial needle and venous needle. Or else, it will endanger patients.

- Handle the used consumables

- Take down the dialyser, blood tube and substitution tube etc from the machine.
- Please abandon the used tubes, filters and syringes etc according to the abandon procedures in hospital.

## 6.7 Power cut handling during treatment

If the power cut during the treatment, the main engine will turn to battery. At the same time, the dialog box will show on the screen and there will be sound and light alarm, the substitution pump and UF pump will stop operation. Please stop treatment promptly and operate blood returning (recover blood).

### 6.7.1 Blood return by backup battery

When the power cut, you can operate blood pump by using backup battery and return blood back.



If the new battery is full with power, it can maintain operating blood pump for 40min. According to the charge state, the time may be shorter even the pump can not be operated.

When the pump can not be operated by the power of battery, you can turn blood pump by hands to operate blood returning in the next chapter.

### 6.7.2 Blood return by hand

As the following shows, blood return by hand:

- Open the pump cover
- Revolve blood pump with the direction of red arrowhead by hand to return the blood.
- After the blood return, take down the venous needle in the venous blood circuit from patients.



Please revolve blood pump according to the direction of arrowhead (red).

If revolve backwards, the blood will back flow, and it may endanger patients.

# 7 Alarm and measures

## 7.1 Alarm

During the treatment and operation, to prompt working state or it needs doctor to go on the next step, and there is something wrong (or maybe something wrong), the machine will prompt or alarm through following three methods:

- The alarm information pop up on the LCD.
- Alarm indicator is light or flickering.
- Alarm sound

When there is alarm, please handle according to the LCD information in this manual and this chapter.

If there is still alarm after handling, and you do not know alarm reasons and handle measures, please contact with nearest service department and technical support engineer of our company.

Sound pressure levels of auditory alarm signal are more than 65 dB(A).



When the machine' s alarm happens repeatedly with unknown reasons, please don' t do treatment; if it is already to do treatment, please stop and return blood.

When the machine error happens, it may be unable to continue treatment.



Some alarms can be closed temporarily and modify the alarm limit, please set the proper alarm limit.

## 7.2 Alarm categories

Table 7-1 instructions of alarm categories

Alarm level	Indicator light	Alarm melodies	Instructions
High priority	Red Flashing	CCC-CC	Safety alarm: a series of actions will occur after the alarm is triggered, which changes the original operation state. It needs immediate treatment or shutdown and restart, otherwise it will cause certain harm to the patient and even threaten the life and safety of the patient. The operator must intervene, press the "Mute" button, and the alarm lamp will continue to flash. If not eliminated, continue after 1 minute. The alarm light will not change from flashing red to green until the condition that triggers the alarm indicator disappears or is properly handled by the operator.
Medium priority	Yellow Flashing	CCC	Automatic recovery alarm: after the condition of triggering the alarm is eliminated, the buzzer (alarm sound), LED indicator flicker and pop-up window on LCD will be automatically stopped and restored to normal state.  Alarm for operation intervention: it is necessary for medical staff to manually eliminate the trigger condition of the alarm, and then touch the corresponding key to cancel the alarm, and then return to the normal state.

The color-coding of indicator light satisfies IEC 60601-1 Cl.7.8.1 and IEC 60601-1-8 Cl.6.3.2.2.

### 7.2.1 Basic action when there is an alarm



Pressing "mute" Can eliminate alarm sound temporarily. Mute is 1 min. If the time is up, and the alarm is still here, the alarm sound will be triggered automatically.

## 7.2.2 Alarms related to blood

When alarms related to blood occur, the machine executes as follows:

- The alarm indicator (red) will be flash.
- The alarm sounded.
- The blood pump stop.
- The UF pump stop.
- The block pump closes (VP lower or air alarm etc.).
- Pop up alarm window, and display alarm information.

## 7.2.3 Alarms related to dialysate

When alarms related to dialysate occur, the machine executes as follows:

- The alarm indicator (red) is flashing
- The alarm sounded.
- The UF pump is stopped.
- Dialysate bypass.
- Heating system is stopped.
- Pop up alarm window, and display alarm information.

## 7.2.4 Alarms related to blood and dialysate

When alarms related to blood and dialysate occur, the machine executes as follows:

- The alarm indicator (red) is flashing.
- The alarm sounded.
- The blood pump is stopped.
- The UF pump is stopped.
- Venous occlusion clamp is closed (VP lower or air alarm etc).
- Dialysate bypass.
- Heating system is stopped.
- Pop up warning window, display alarm information.

## 7.2.5 Alarms related to interruption of power supply

When alarms related to interruption of power supply occur, the machine executes as follows:

- The alarm indicator (yellow) is flashing.
- An auditory alarm signal is activated after 5s.
- Hydraulic system is stopped.
- The blood pump keeps working for more than 40min.
- Pop up alarm window, and display alarm information.

## 7.3 Cause and solution of alarm, caution and prompt

Table 7-2 Common faults and methods

No.	Fault phenomenon	Fault phenomenon and cause		Handling method
1	Blood pump abnormal	Blood pump stop	Blood pump flow is "0"	Increase the blood pump flow
			Block clamp does not return	Return the block clamp
		Motor rotates instability	Pump head gap is not appropriate	Adjust the pump head gap
			Circuit board or motor fault	Change the circuit board or motor
		Rotate too fast or too slow	Blood pump maladjusted	Adjust blood pump flow
			The auxiliary circuit board or motor fault	Change the auxiliary circuit board or motor
		Send abnormal voice	Drive shaft bearing wear	Change the bearing
			Pump wheel screw loosening, clearance between the pump wheels is too large	Clockwise rotate the pump wheel and adjust screw (when it is 8r/min, the fluid should be pumped), until there is no sound.
			Wrong arterial puncture	Puncture again
		Can not lead blood out	Blood pump wheel	Counterclockwise loosen

No.	Fault phenomenon	Fault phenomenon and cause		Handling method
			is too tight	pump wheel and adjust screw (adjust 0.5r each time)
2	Heparin pump stop	Heparin motor stop	Motor connector breakage or poor contact	Change connector
			Circuit board fault	Change circuit board
			Motor broken	Change motor
		Heparin motor rotate	Syringe is not installed well	Install syringe again
			The coupling slips	Adjust coupling
			The drive nut damage	Change the drive nut
3	The speed of the heparin pump is slow	The speed of the heparin is set too low		Reset the heparin speed rate in the system parameter on the LCD
4	Air alarm	There is bubble	There is air in the blood tube	Degas
		There is no bubble	There is no air detector in the blood circuit	Install blood tube again. Let bubble catcher on the surface of the sensor as far as possible.
			Wrong connection between the blood tube and sensor	Install blood tube again
			Sensor joint bolt	Change the sensor
			Sensor circuit board fault	Change the circuit board or sensor
5	Blood leakage alarm	Blood leakage	Check whether there is blood leakage by checking dialyser outlet port with eyes or experimental equipment.	Change filter
6	The arterial pressure/venous pressure/TMP does not display	Pressure port does not connect pressure		Connect pressure tube with pressure detector port

No.	Fault phenomenon	Fault phenomenon and cause	Handing method
		The sensor cover is blocked	Remove the fluid in the sensor cover or change the sensor cover
		Sensor has not been calibrated	Calibrate to sensor according to requirements
		Sensor damage	Apply for maintenance
7	Block clamp does not return	The gap between the block and turntable is too small.it is completely blocked.	A. Repeatedly rotate switch, and then press air. B. If it can not be handled by a method, please contact with professional maintenance engineer.
8	The clock does not display	Button cell battery runs out	Open the rear cover, and then change button cell battery.
9	IV pole bracket loosen	Screw can not lock IV pole tightly	Change the screw
10	Negative degas is insufficient	QP is rubbed	Increase the rate of QP
		Orifice is rubbed	Change orifice
11	Negative degas is too high	Orifice is blocked	Decalcification to fluid circuit
			Clean the orifice
12	(heater-leakage of electricity)	The heating pipe in the heater is damaged	Change heater
13	(heater-temperature sensor)	The temperature sensor in the heater is damaged	Change the temperature sensor
14	Dialysate temperature upper limit alarm	There is bubble in the inner fluid circuit	Change air leakage components
		WG4 is damaged	Change temperature sensor
15	Dialysate temperature lower limit alarm	There is bubble in the inner fluid circuit	Change air leakage components
		WG4 is damaged	Change temperature sensor
		The heating pipe in the heater is damaged	Change heater
16	The temperature in the	The temperature sensor in the A	Change temperature

No.	Fault phenomenon	Fault phenomenon and cause	Handing method
	A conductivity sensor is abnormal	conductivity is damaged	sensor
17	The temperature in the B conductivity sensor is abnormal	The temperature sensor in the B conductivity is damaged	Change temperature sensor
18	Balance chamber is abnormal	V1 ~ V8 valve is damaged	Change valve
		There are too many bubbles in the fluid circuit	Restart the machine, and then rinse the machine.
		QP,DP or YP faults	Change gear pump
		XV1 or XV2 faults	Dismantle and clean XV1 or XV2
		YG2 or YG4 faults	Change pressure sensor
19	Balance chamber stop	V1 ~ V8 is damaged	Change valve
		There are too many bubbles in the fluid circuit	Restart the machine, and then rinse the machine
		QP,DP or YP faults	Change the gear pumps
		XV1 or XV2 faults	Dismantle and clean XV1 or XV2
		YG2 or YG4 faults	Change pressure sensor
20	UF faults	JP3 is damaged	Change ceramic pump
21	Can not start the machine	Haven' t connected the power connector	Connect power well
		Fuse is damaged	Change fuse

## 7.4 Alarm action, cause and solution

No.	Alarm message	Alarm cause	Alarm level	Relative action
001	VP lower limit alarm	VP is lower than set limit	High priority	Close blood pump, block clamp, bypass, heparin pump, substitution pump and UF.
002	VPupper limit alarm	VP is higher than set limit	High priority	Close blood pump, block clamp, bypass, heparin pump, substitution pump and UF.

No.	Alarm message	Alarm cause	Alarm level	Relative action
003	Air alarm	There is bubble in the air detector	High priority	Close blood pump, block clamp, bypass, heparin pump, substitution pump and UF.
004	Blood leak	There is blood leakage in the waste	High priority	Close blood pump, bypass, heparin pump, substitution pump and UF.
005	TMP upper limit alarm	TMP is higher than set limit	High priority	Close blood pump, bypass, heparin pump, substitution pump and UF.
006	TMP lower limit alarm	TMP is lower than set limit	High priority	Close blood pump, bypass, heparin pump, substitution pump and UF.
007	AP upper limit alarm	AP is higher than set limit	High priority	Close blood pump, bypass, heparin pump, substitution pump and UF.
008	AP lower limit alarm	AP is lower than set limit	High priority	Close blood pump, bypass, heparin pump, substitution pump and UF.
009	Blood pump cover open	When blood pump is open, the blood pump cover will open.	High priority	Blood pump stop (blood pump is still light), bypass, close heparin pump, substitution pump and UF.
010	Power supply failure	The power supply is failed during the operation	Medium priority	Bypass, close substitution pump, UF, heater, balance chamber and fluid mixing system.
011	Low conductivity	Cond. B value is lower than set value (+5%)	Medium priority	Bypass, close substitution pump and UF.

No.	Alarm message	Alarm cause	Alarm level	Relative action
012	High conductivity	Cond. B value is higher than set value (-5%)	Medium priority	Bypass, close substitution pump and UF.
013	Temp. Upper limit alarm	The dialysate temperature is higher than set limit	Medium priority	Bypass, close substitution pump and UF.
014	Temp. Lower limit alarm	The dialysate temperature is lower than set limit	Medium priority	Bypass, close substitution pump and UF.
015	Dialysate pressure upper limit alarm	The dialysate pressure is higher than upper limit	Medium priority	Bypass, close substitution pump and UF.
016	Dialysate pressure lower limit alarm	The dialysate pressure is lower than lower limit	Medium priority	Bypass, close substitution pump and UF.
017	High A conductivity	A conductivity is higher than set value	Medium priority	Bypass, close substitution pump and UF.
018	Low A conductivity	A conductivity is lower than set value	Medium priority	Bypass, close substitution pump and UF.
019	Negative pressure failure	Negative pressure is lower than requirement	Medium priority	Bypass, close substitution, UF, BC, heater and fluid mixing.
020	Blood pump error	Blood pump is blocked while operation	High priority	Blood pump stop (blood pump is still light), bypass, close heparin pump, substitution pump and UF.
021	Substitution pump error.	Substitution pump is blocked while operation	Medium priority	Close substitution pump
022	Sub. Pump cover open	The substitution cover is open when substitution is open	Medium priority	Close substitution pump
024	Heparin pump reaches the bottom.	Heparin pump has reached the bottom	Medium priority	Stop heparin pump

No.	Alarm message	Alarm cause	Alarm level	Relative action
025	BC system stop	Balance chamber stop working	Medium priority	Bypass, close substitution, UF, heater and fluid mixing.
026	Connect red aspiration to A concentrate.	BC and pyrogen filter pass the self test. If A aspiration is still in the machine while self test, it will alarm.	Medium priority	Self test will stop at this state
		If A aspiration is still in the machine under treatment or standby mode, it will alarm.		Stop A,B pump
023	Connect blue aspiration to B concentrate	BC and pyrogen filter pass the self test. If B aspiration is still in the machine while self test, it will alarm.	Medium priority	Self test will stop at this state
		If B aspiration is still in the machine under treatment or standby mode, it will alarm.		Stop A,B pump
027	Please insert red aspiration tube to rinsing port.	A aspiration is not connected with machine under clean and disinfection mode.	Medium priority	The procedure stops at original state
029	Please insert blue aspiration tube to rinsing port.	B aspiration is not connected with machine under clean and disinfection mode.	Medium priority	The procedure stops at original state
028	Close bicart.	YJ4 is open under clean and disinfection mode	Medium priority	Stop clean and disinfection
033	Water supply failure	Dialysis water supply abnormal	Medium priority	Bypass, close substitution pump, UF, BC, heater and fluid mixing.

No.	Alarm message	Alarm cause	Alarm level	Relative action
034	Please connect the red/blue coupling to rinsing bridge.	Dialyser couplings are not connected with machine under the clean mode	Medium priority	Clean stops at original state
035	Please connect the red/blue coupling to dialyser.	Dialyser couplings are not connected with dialyser under the treatment mode	Medium priority	Close substitution pump and UF
036	Block clamp error.	Block clamp is in the closed position	High priority	Close blood pump, bypass, heparin pump, substitution pump and UF.
037	Bubbles in dialysate.	There are too many bubbles in the dialyser	Medium priority	Open bypass, and close substitution and UF.
039	Abnormal conductivity sensor B and C	The value of B,C conductivity is different too much	Medium priority	Bypass, close substitution
041	HD completed	The set time is up or close the dialysis and enter the finish mode	Medium priority	Back to treatment finish mode and close UF.
042	HF completed	The set time is up or close the dialysis and enter the finish mode	Medium priority	Back to treatment finish mode, close UF and substitution pump.
043	HDF completed	The set time is up or close the dialysis and enter the finish mode	Medium priority	Back to treatment finish mode, close UF and substitution pump.
044	Prime completed	The set time is up or close the dialysis and enter the finish mode	Medium priority	Back to treatment finish mode, close UF and substitution pump.
045	Seq.UF complete	The set time is up or close the dialysis and enter the finish mode	Medium priority	Back to treatment finish mode, close UF.

No.	Alarm message	Alarm cause	Alarm level	Relative action
047	BC-diaphragm error	The tube connected with dialyser is folded	Medium priority	Bypass, close substitution, UF, BC, heater and fluid mixing.press "start" To open balance chamber and back to heat and fluid mix.
049	BC system error	Balance system is abnormal	Medium priority	Bypass, close substitution, UF, BC, heater and fluid mixing.press "start" To open balance chamber and back to heat and fluid mix.
051	Inlet pressure(YG2) exceeds high limit	Balance system is abnormal	Medium priority	Bypass, close substitution, UF, BC, heater and fluid mixing.press "start" To open balance chamber and back to heat and fluid mix.
052	Outlet pressure(YG4) exceeds high limit	Balance system is abnormal	Medium priority	Bypass, close substitution, UF, BC, heater and fluid mixing.press "start" To open balance chamber and back to heat and fluid mix.
053	SV14 leak	There is leakage in the SV14	Medium priority	Bypass, close substitution and UF.
054	B.P. Rate lower than UF,adjust B.P. Rate	When the blood pump is open, the rate of the blood pump is less than the rate of the UF.	Medium priority	NULL
055	Heperin pump failure	The heparin pump is not open.	Medium priority	NULL

No.	Alarm message	Alarm cause	Alarm level	Relative action
062	UF pump flow failure 2	The actual rotation rate of the UF pump is abnormal.	Medium priority	Stop treatment
065	Abnormal dialysate temperature sensor	The temperature contrast of the dialysate WG4, WG6 is too big.	Medium priority	Bypass, close UF and substitution pump.
066	UF rate is limited,postpone the treatment.	The actual UF rate is too big.	Medium priority	Stop treatment
070	Can not take the sub. Fluid flow	If the "filter" Is "OFF" , there will be alarm prompt whenever open the substitution pump.	Medium priority	Null
071	DF filter expired (prompt alarm; the color is yellow)	The usage time of the DF filter is more than its allowable time.	Medium priority	Null
072	HDF filter expired (prompt alarm; the color is yellow)	The usage time of the HDF filter is more than its allowable time.	Medium priority	NULL
073	QG2 or surrounding tube leak	While rinse+decal,there is leakage in QG2 or surrounding tubes.	High priority	Stop disinfection
083	Low A conductivity.	The difference between A solution set conductivity and actual conductivity is more than required value.	Medium priority	Stop the treatment
084	High A conductivity	The difference between A solution set conductivity and actual conductivity is less than required value.	Medium priority	Stop the treatment
085	Low B conductivity	The difference between B solution set conductivity and actual conductivity is more than required value.	Medium priority	Stop the treatment
086	High B conductivity	The difference between B solution set conductivity and actual conductivity is less than required value.	Medium priority	Stop the treatment

## 7.5 Measures for alarm



If the alarm is continuous and can not be removed, please call customer service hot-line or contact with after-sale service engineer.



Except these alarms, close VP, TMP, or air alarm functions during the treatment over a certain time, it will also cause alarm.

### 7.5.1 VP alarm

It will alarm if the VP value is higher or lower than set limit.

Measures:

- Press **【mute】** to stop alarm sound.
- Check following items:
  - Blood circuit (especially the filter) is blocked (coagulate).
  - Blood circuit is compressing or bending.
  - The puncture state about connection parts of patients
  - The adjust state of the blood pump gap
  - Whether there is fluid in the hydrophobic air filter.
  - Blood flow
  - Whether the alarm limit is set reasonably etc.
- Eliminate alarm reason.
- Press  to start the treatment again.

## 7.5.2 TMP alarm

It will alarm if the TMP value is higher or lower than the set limit.

Measures:

- Press **【mute】** to stop alarm sound.
- Check following items:
  - Blood circuit (especially the filter) is blocked (coagulate).
  - Blood circuit is compressing or bending.
  - The puncture state about connection parts of patients
  - The adjust state of the blood pump gap.
  - Whether there is fluid in the hydrophobic air filter.
  - The type of the filter
  - Blood flow
  - UF volume
  - Whether the alarm limit is set reasonable etc.
- Eliminate alarm reason
- Press  to start the treatment again.

## 7.5.3 AP alarm

It will alarm if the VP value is higher or lower than the set limit.

Measures:

- Press **【mute】** to stop alarm sound.
- Check following items:
  - Blood circuit (especially the filter) is blocked (coagulate).
  - Blood circuit is compressing or bending.
  - The puncture state about connection parts of patients
  - The adjust state of the blood pump gap.
  - Whether there is fluid in the hydrophobic air filter.
  - Blood flow
  - Whether the alarm limit is set reasonable etc.

- Eliminate alarm reason.
- Press  to start the treatment again.

### 7.5.4 Blood pump alarm

It will alarm if the blood pump cover is open or blocked.

Measures:

- Press **【mute】** to stop alarm sound.
- Check following items:
  - Whether the blood pump cover is closed in place, and whether there is dislocation.
  - Whether the pump tube meets the requirements.
  - The adjust state of the blood pump gap.
  - Whether there is impurity in the pump.
  - Whether the pump cover is loose.
- Eliminate alarm reason.
- Press  to start the treatment again.

### 7.5.5 Substitution pump alarm

It will alarm if the substitution pump cover is open or blocked.

Measures:

- Press **【mute】** to stop alarm sound.
- Check following items:
  - Whether the substitution pump cover is closed in place, and whether there is dislocation.
  - Whether the pump tube meets the requirements.
  - The adjust state of the substitution pump gap.
  - Whether there is impurity in the pump.
  - Whether the pump cover is loose.
- Eliminate alarm reason.
- Press  to start the treatment again.

## 7.5.6 Air alarm

It will alarm if there are too many bubbles in the air detector.

Measures:

- Press **【mute】** to stop alarm sound.
- Check following items:
  - Whether the fluid level is too low in the venous bubble catcher.
  - Whether the bubble has passed through the tubing air detector.
  - Whether the tube is installed well.
- Open the cover and clamp on the bubble catcher, push bubble into the venous bubble catcher, and then close cover and clamp.
- If it is necessary, please up the blood level in the bubble catcher.
- If it is necessary, move the installation site of the tube.
- Open the block clamp.
- Press  to start the treatment again

## 7.5.7 Blood leakage alarm

It will alarm if there is blood leakage in the filter

Measures:

- Press **【mute】** to stop alarm sound.
- Check following items:
  - Check whether the blood leakage is in the waste. If there is blood leakage, please check whether the dialyser is a lack of membrane.
  - Whether there is impurity in the blood leak sensor glass.
- Eliminate alarm reason.
- Press  to start the treatment again.

# 8 Rinse and disinfection

## 8.1 Rinse and disinfection procedures and notes

The disinfection modes are mainly divided into two as follows:

Table 8-1 Disinfection mode

No.	Disinfection mode	Requirement
1	Chemical disinfection	a) Disinfectant: Sodium hypochlorite. b) Initial concentration: 5%. c) Concentration of diluted solution in machine: 0.05% ~ 0.15%. d) The duration of disinfection: 10 ~ 40 min. e) The duration of rinse after disinfection: 12 ~ 30 min. f) The remnants of chloride concentration are less than 0.1 mg/l after rinse.
2	Heat disinfection	a) Disinfectant: Citric acid. b) Initial concentration: 30%. c) Concentration of diluted solution in machine: 1.5% ~ 2.5%. d) The duration of disinfection: 18 ~ 50 min. e) The duration of rinse after disinfection: 12 ~ 30 min. f) The PH value of disinfectant residual volume is 6~7 after rinse.

The rinse modes are mainly divided into two as follows:

Table 8-2 Rinse mode

No.	Rinse mode	Duration	Mark
1	Rinse	12~30 min	Use the RO water to clean.
2	Heat rinse	36~100 min	The fluid temperature of heater' s outlet is more than 93°C

Except these, you can also start on the parameter set window or remove following items:

- Disinfection after each treatment
- Timing automatic disinfection
- Turn off the machine after disinfection

#### Recommended disinfection solution

We suggest using 30% citric acid (heat disinfection) or 5% sodium hypochlorite solution (chemical disinfection) as disinfectant.



We advise you to use the citric acid came from professional factory.  
If you use the disinfectant of your own, the crystal may cause the tubes and valves blocked.



Disinfect machine after each dialysis treatment. Decalcification every two days.

When using self-choose disinfection solution, we cannot guarantee the effect of rinse and disinfection.

If the machine is not used for a period of time, even a while (48 hours), it is needed to execute disinfection before dialysis treatment.



If there is disinfection solution leaking from connector, it may cause empyrosis or chemical burn.

Do not dismantle dialyser connector.

Do not pull out concentrate aspiration.



If the concentrate is blowout or slop out, it may cause chemical burn to users.

Pay attention to take some measures, such as: wear protective suit, eye shield or mask.

Rinse the disinfection solution on the skin or clothes with clean water.



When the machines is running hot disinfection or hot cleaning procedures, it is forbidden to touch the silicone tubes outside the machines to avoid burns.



During the running of the thermal disinfection or thermal cleaning program, please do not remove the dialyzer connector or pull out the concentrated liquid suction tube to avoid burns.



After the machines has performed hot disinfection or hot cleaning procedures, wait for the machine to cool down before opening the covers to do maintenance to avoid burns.



If the disinfection solution remains in the machine, it may cause haemolysis to endanger patients.

After each disinfection, it is needed to check residual disinfection solution recently, or else it may endanger patients.



No matter what the situation, it is needed to guarantee finishing disinfection or executing rinse forcibly.



Only the disinfection procedures defined and validated by the manufacturer shall be used for ONLINE HDF and ONLINE HF.



Please follow the MANUFACTURER' S instructions to disinfect the HEMODIALYSIS EQUIPMENT, otherwise it may cause contamination or pyrogenic reaction due to inadequate disinfection; if other PROCEDURES are used it is the responsibility of the RESPONSIBLE ORGANIZATION to validate the disinfection PROCEDURE for efficacy and safety.



Unknown ingredients of disinfectant or wrong disinfection method may damage the internal tubing system which may result in incorrect UF flow.

Do follow this manual to disinfect machine, otherwise we will not guarantee the efficacy and safety of other disinfection procedures.



The responsible organization is responsible for the hygienic quality of:

Central dialysis water supply system;

Central delivery systems;

Machine connecting devices;

The fluid lines from connection points to the machine.

## 8.2 Rinse and disinfection preparation

### 8.2.1 Check disinfection solution



Please do not mix the chlorine disinfectant and citric acid solution.

When add disinfection solution (sodium hypochlorite) and decalcification solution (citric acid) into the medicine bottle (barrel), please supply the medicine solution which is same as the labels marked.

Mix the chlorine disinfectant with acetic acid will produce a lot of chlorine gas.

The concentration of citric acid must be same as the set of machine.

- Please check whether the disinfection solution bottle rear this machine is filled with enough medicine solution.
- If the residual medicine solution is less in the medicine bottle, please add some medicine solution according to the labels on the disinfection bottle.
  - Ensure the connected Disinfection solution is usable and the flow is enough.
  - If it is necessary, change disinfection bottle.
  - It is needed to consider that it may start another disinfection period automatically later.



After open the package of disinfection solution and acid, please avoid volatilization and its validity. Or else we can not guarantee disinfection and decalcification effect.

## 8.2.2 Rinse and disinfection starting condition

- Please ensure that dialyser connection tube is connected with the connector of machine.
- The concentration aspirations should be connected with machine.
- Blood leak sensor in the air detector has not detected blood.

## 8.3 Rinse and disinfection interface

Touch **[rinse+disinf.]** to enter the rinse and disinfection selection window, as pic. 8-1



Pic. 8-1 Rinse and disinfection window

- The left dialog in this window are the normal, system default modes of rinse and disinfection.
- The right dialog in this window are the details of the selection modes, the pic. 8-1 is the

details of heat rinse , the heat rinse has three steps :

- Ro water clean for 8minutes.
- High temperature rinse for 30 minutes.
- RO water clean for 15 minutes.

- Click the  "Run" button to start the rinse and disinfection.
- The color and layout of this interface may different because of software version and different machines

## 8.4 Operation Process

- As the pic. 8-1, click profile under the "solution" .
- If you need modify the rinse parameters, please do it as follows:
  - Chose the revised item to modify in the dialog under the "details" .
  - The machine will skip a dialog to set the parameters, and finish modify.
  - This method is valid for this time, When turn on machines for next time, it will be the the default values again.
- The medical staff can click the  "run" button to start rinse and disinfection after confirm all the rinse steps.
  - Generally, the medical staff does not need modify the default values of rinse solution, just click the "run" to start rinse and disinfection.
  - The medical staff can not add or delete the rinse steps, just can change the water temperature, and solution components of rinse steps.

## 8.5 Rinse and disinfection ending

After rinse and disinfection, user can press "power" to turn off machine directly, or set parameter which is to close rinse and disinfection automatically to realize closing machine. If turn off the machine forcibly during the rinse and disinfection, the machine will automatically rinse and disinfection when turn on the machine on next time. It is to clean residual disinfection solution.



During the disinfection, there are harmful substances in the machine. Please do not turn off machine forcibly, or else it will endanger patients.

# 9 Single Needle - Optional

## 9.1 Overview

Single needle program is used for dialysis patients that, for several reasons, shouldn't be connected through a double needle vascular access (es. during fistula maturation period or an emergency). For single needle dialysis, the patient needs only one needle with which the blood is alternately collected from and returned to the patient. The arterial and venous terminals of the blood line are connected by a Y-piece tube. Compared to double needle dialysis, single needle treatment mode can reduce the number of punctures by half.



Single needle program is used as an "emergency procedure" for exceptional cases only and is used when there is a problem with double needle procedure.



Dialysis treatment efficiency with single needle procedure will decrease.



Air may enter into the EXTRACORPOREAL CIRCUIT downstream of the air detector, if pressures are negative.



Single needle procedure can only be available during HD mode and IUF mode.

## 9.2 Function Introduction

Single needle program can be used on both SWS-6000 and SWS-6000A hemodialysis machines. During the procedure, only blood pump is working for extracorporeal blood circulation. If there is substitution pump, it remains in the shutdown state.

Regarding blood collection from and return to patient (fig.9-1), it is illuminated as below:

➤ Blood collection phase:

The venous block clamp is closed; the blood pump is running to pump the blood from the patient through the arterial chamber and the dialyser into the venous chamber. The pressure in the venous chamber is monitored by the venous pressure sensor. When the venous pressure rises to the "Control Max PV", it will switch to blood return phase.

➤ Blood return phase:

The blood pump stops, the venous block clamp opens, and the blood returns into the patient through the venous chamber until the venous pressure drops to the "Control Min PV" or reaches the preset returning time. It will then switch to blood collection phase again, till now it is completion of a circulation period and this alternation lasts until single needle treatment time expired

During the blood return phase, if the blood return time has reached but not the venous pressure "Control Min PV", phase switch will still be performed.

The blood return time for the first three periods is set at maximum 10s, after that, it is set based on the average time of the first three periods.

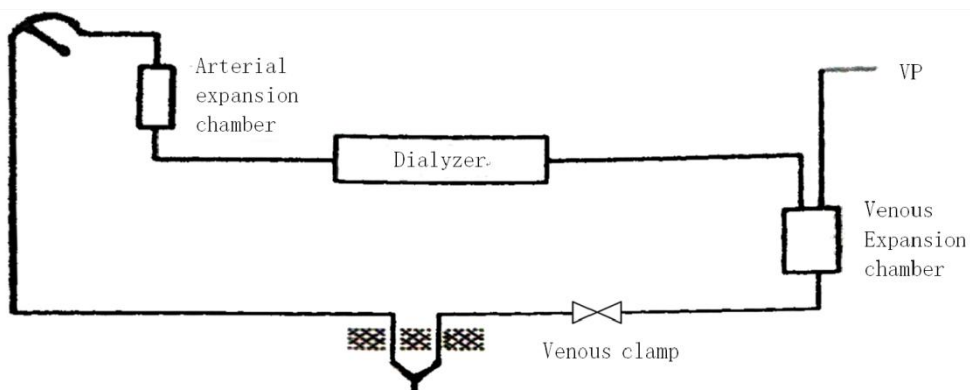

Pic. 9-1 Single Needle Procedure Management System

Definition:

$$Q_{SN} = k \cdot R_{SN}$$

$Q_{SN}$  = the effective delivered blood flow rate in single-needle treatments, unit: ml/min

$k$  = the blood pump segment, unit: ml/r

$R_{SN}$  = revolutions of blood pump in one minute in single-needle treatments, unit: r/min

The intended maximal recirculation volume (i.e. the volume between intersection of arterial and venous blood line at patient access and cannula tip) is 2 ml.

### 9.3 Parameter Settings

As figure 9-2 shows, the systematic switch of single needle feature should be activated in the Parameter4, switch parameter "Single Needle" to "ON" , the single needle procedure and corresponding parameter setting can be available.

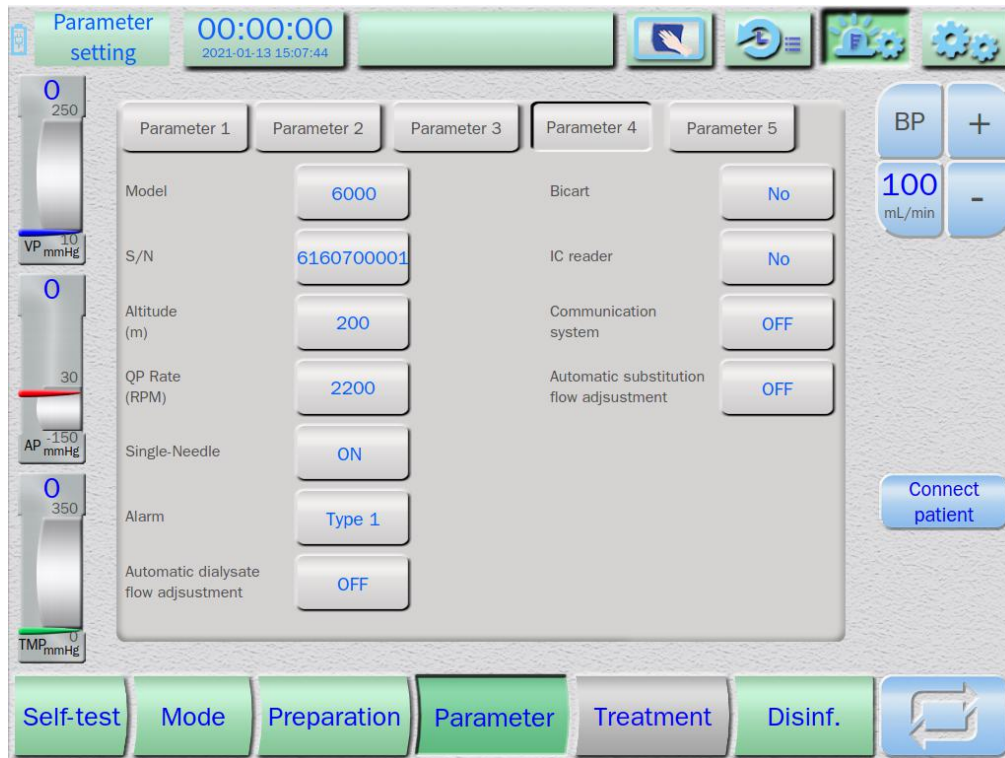

Fig9-2 Systematic switch of single-needle



Fig.9-3 Single needle dialysis parameters settings

If the "Switch" is "ON", the Single-Needle treatment procedure will be performed. If the "Switch" is "OFF", machine will switch back to double needle treatment procedure.

The "Control Max PV" value ranges 200 ~ 390 mmHg. The "Control Min PV" value ranges 20 ~ 150 mmHg.

#### Recommendations:

During the single needle treatment procedure, the following stroke volume should be reached:

- The standard tubing system with 30 ml venous chamber: 12-18 ml.
- The tubing system with 100 ml venous chamber: 15-25 ml.

It is recommended to set parameter "Control Min PV" to 120~150mmHg, and "Control Max PV" to 300mmHg.

Pay attention to the blood level in the venous chamber during the process, for a better stroke volume, the basic liquid level should not exceed 35%, and the stroke volume should not be less than 12 ml.

The stroke volume is related to:

- Blood level in the venous chamber;
- Changes in the blood flow;

- The setting of "Control Max PV" and "Control Min PV" ;
- The pressure changes in the blood tubing;
- The blood pump stops due to some alarms.

If necessary, adjust the blood level in the venous chamber through the VP level regulator, or adjust the "Control Max/Min PV" .



Single needle procedure can be available during double needle dialysis.



The user must set the proper blood level in the venous chamber during the single needle procedure.



If the venous pressure sensor protector is contaminated by the blood, the patient will be at risk of infection. The corresponding protector must be replaced with a new one. Please contact the service for replacement when necessary.

## 9.4 Alarms

During the single needle dialysis treatment, in addition to the arterial pressure, venous pressure and transmembrane pressure alarms, the upper limit of VP alarm is set to 400 mmHg, and the lower limit of TMP alarm is set to -100 mmHg, other alarms keep consistent with double needle procedure.

Single needle dialysis alarms are listed in the table below:

Tab. 9-1 single needle dialysis alarms table

No.	Alarm level	Alarm message	Alarm condition	Alarm mode	Action
1	High priority	Big volume of blood exchange chamber	The blood pump has run for a long time and the pressure doesn' t reach the "Control Max PV", alarm arises.	Single needle dialysis treatment	Stop the blood pump, heparin pump substitution pump, ultrafiltration pump, block clamp, substitution fluid,

					treatment time and dialysate bypass.
2	High priority	Small volume of blood exchange chamber	If blood collection phase time is too short, alarm arises.	Single needle dialysis treatment	Stop blood pump, heparin pump substitution pump, and ultrafiltration pump, block clamp, substitution fluid, treatment time and dialysate bypass.

# 10 Maintenance



According to the maintenance plan, regularly check the leakage current and dielectric strength of the equipment.



Replacement of parts should only be carried out by trained personnel.

Adhering long-term correct daily maintenance and repair is good for machine' s normal function and prolonging service life.

## 10.1 Repair and Maintenance

### 10.1.1 Equipment external clean

Wipe off the blood, water and other substance on the external of the equipment by moist or soft cloth. Corrosive concentration is not allowed.



While cleaning the detect connector of AP, VP, outside membrane pressure and substitution pressure, do not let fluid into connector to avoid sensor malfunction.



Do not wipe the equipment by disinfectant, such as sodium chlorate diluent. Sodium chlorate will resolve chlorine. Chlorine is harmful to human and the electrical parts of machine.

### 10.1.2 Heater

Check whether there is water leak in the heater, and whether the connecting lead of heater is tight.

### 10.1.3 Pump

There are two pumps, blood pump and substitution pump(SWS-6000). The structure and maintenance methods of these two pumps are the same.

- 1) Clean: Use alcohol to clean, and it can be dismantled.
- 2) Pump head dismantle

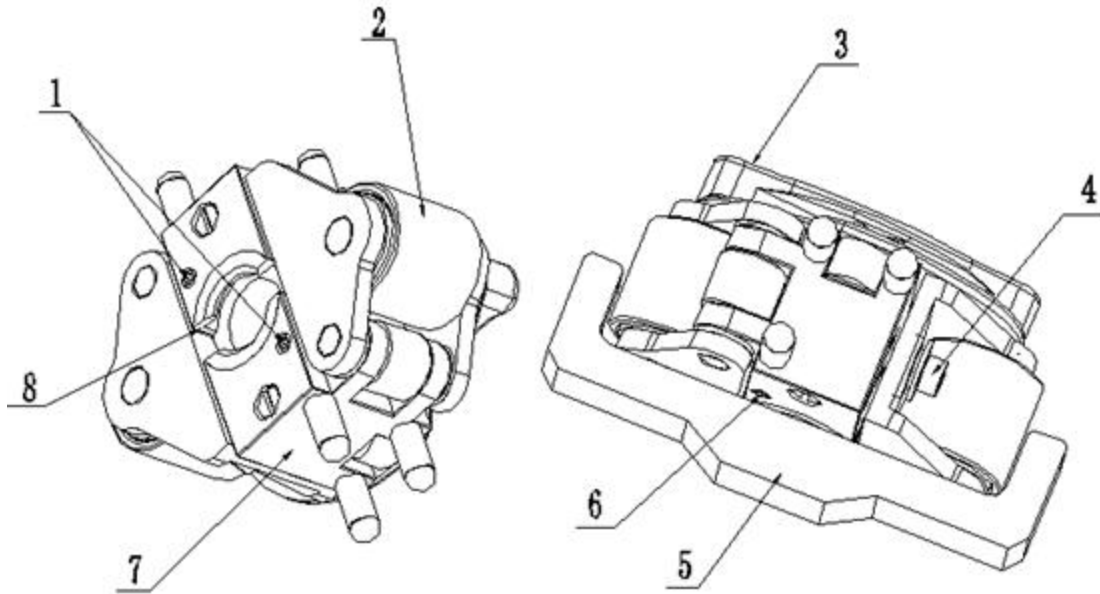

Pic. 10-1 Pump head wheel operation

- |                  |                        |
|------------------|------------------------|
| 1-holding screw  | 2-pump roller          |
| 3-handle         | 4-spring tighten screw |
| 5- pump spacing  | 6-holding screw        |
| 7-pump head body | 8-slot                 |

### 10.1.4 Mains fuse chngement

If it is needed to change mains fuse, please change according to labels and specifications. Use screw to open cover to exchange broken fuse, then recover the cover. The specifications of fuse is 15A/250V (Φ6.3×32mm), and label on the protective tube installation site.

## 10.2 Serviceman check and repair

Except special requirements, this machine should be checked every 6 months. If there is abnormal, it should be repaired by professionals with repair qualification. The check and

repair methods should according to <SWS-6000serise dialysis machine maintenance manual>

### **10.2.1 Internal cleaning**

Use cleaner or clean cotton cloth to clean the internal. Before cleaning, take off the plug

### **10.2.2 Confirm the protective grounding resistance is less than 1Ω**

### **10.2.3 Confirm the accuracy of AP,VP and exterior membrane pressure sensor**

- Prepare one hemodynamometer that has been calibrated.
- Open the machine. When there is a progress bar, use hand to draw a line from right to left on the screen, and enter the pressure test calibration window.
- It will check whether the values of the pressure sensor is accuracy when there is no pressure.
- Add pressure 200mmhg to pressure detect connector. Check whether the pressure detector detects right.
- If the pressure sensor is abnormal, mark down the abnormal pressure sensor and calibrate it

### **10.2.4 Confirm the pump tube coefficient**

- Prepare blood lines, filter, clock, measuring cup(1L) and container.
- Install blood lines and filter on the machines, operate disinfection.
- 150ml/min; adjust blood pump flow to 150ml/min.
- Take the arterial terminal of blood line into container with full water; take the venous terminal into the measuring cup.
- 2min later, check the water as 300ml±10%.
- If the flow deviation beyond ±10%, use the actual volume of measuring cup divided by blood pump rotates numbers per min and measuring time 2 min, the parameter is blood pump pump tube parameter.(pay attention to omitting decimal fractions smaller than 0.5 and counting all others, including 0.5, as 1 )
- Input the parameter to "BP segment" , then press "enter" To save the pump

tube parameter of blood pump.

- Operator also can skip sixth step.directly adjust pump tube parameter of blood pump under the “BP segment” , ensure the display flow and the actual flow deviation is less than  $\pm 10\%$ .
- When confirming substitution pump pump tube parameter, install the blood lines on the substitution pump, adjust the pump speed to 50ml/min; delay the test time 5 min. Confirm or revise the substitution pump pump tube parameter according to the above steps.

### 10.2.5 Confirm precision of heparin pump

- Prepare syringe (20ml).
- Fill syringe with water and adjust the infusion speed of the heparin pump as 10ml/h and run for one hour.
- Confirm the actual infusion amount is  $10\text{ml}\pm 0.5\text{ml}$ .
- If the flow deviation beyond  $\pm 0.5\text{ml}$ , user could call for repair.

### 10.2.6 Confirm air detector

- Install bubble catcher with water on the air sensor and keep the air detector base and the bubble catcher contact tightly.
- Open the air detector and ensure no air alarm.
- Infuse bubble with syringe at the bottom of bubble catcher. Flick bubble catcher to make bubble go through sensor detecting level or lower the level below air sensor detecting level.
- Ensure air alarm occurs as the above steps. Meanwhile, alarm buzzer sound, the air alarm information display,block clamp close , blood pump stop , heparin pump stop , ultrafiltration pump stop , dialysate bypass ( if UF , the substitution pump stop )

### 10.2.7 Confirm heater

The heater should heat normally. The deviation of display temperature and actual temperature should be in the allowed range. After heat, the insulation resistance of the heat bar should be more than 1M ohm

### 10.2.8 Confirm the blood leak sensor

- Prepare one measurement cup (1000ml), water, animal blood, syringe (2.5ml) and reagent dropper.
- Increase 50 mmHg pressures at the point of venous pressure detector connector and seal.
- Mix 1000ml/1ml blood with water by syringe, measuring cup and animal blood. And mix stir up the solution.
- Put the red and blue coupling into the mixture immediately, and then operate HD procedure.
- Ensure there is blood leak alarm, stop blood pump, UF pump, substitution pump, heater and heparin pump

### 10.2.9 Confirm standby battery

- Use battery to operate after power off at least 3 months. When the battery is operating, the blood pump should operate at least 10 min. If less than 10 min, the battery should be changed as soon as possible. After run out the power of the battery, connect city electricity, and it will charge automatically.

## 10.3 Scheduled maintenance to machine

- We suggest that the schedule maintenance interval time should not be more than 12 months. The maintenance includes checking function, changing vulnerable components. It is to ensure there are no faults in the machine.
- The scheduled maintenance can be only done by authorized operator.











# 11 Symbols and storage





## 11.1 Symbols

### 11.1.1 Symbols on the equipment

Hemodialysis equipment has the product name, type, and manufacturer name, manufacturer marking number, voltage, frequency, power, standard number, registration number and manufacturer license number. The symbols used as follows:

Table 11-1 Symbols

No.	Symbol	Title
1		Alternating current
2		TYPE B APPLIED PART
3		DEFIBRILLATION-PROOF TYPE BF APPLIED PART
4		Protective earth (ground)
5	IPX1	Protection against vertically falling water drops
6		"OFF" (power)
7		"ON" (power)
8		Dangerous voltage
9		Manufacturer
10		Date of Manufacture
11		Authorized representative in the European Community
12		Serial number

No.	Symbol	Title
13		Operating instructions
14		Refer to instruction manual
15		Caution
16		Identification of electric and electronic devices
17		Bell cancel





### 11.1.2 Symbols on the package

1) All the packing case with the following letter mark:

Manufacturer name, product name, type, trademark, standard number, product registration number, manufacturer license number and date of out-factory.

2) The packing case should include the following graphical symbols:

Table 11-2 Package Mark

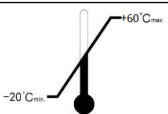
Symbol title	Graphical symbol	Meaning
This way up		This is the correct upright position of the distribution packages for transport and/or storage.
Fragile, Handle with care		Contents of the distribution packages are fragile therefore it shall be handled with care.
Keep away from rain		Distribution packages shall be kept away from rain and be kept in dry conditions.
Do not roll		Distribution packages shall not be rolled or turned over.
Stacking limit by number		Maximum number of identical transport packages which may be stacked on the bottom package, where "n" is the limiting number.
Temperature limits		Distribution packages shall be stored, transported, and handled within temperature limits indicated.

### 11.1.3 Product nameplate

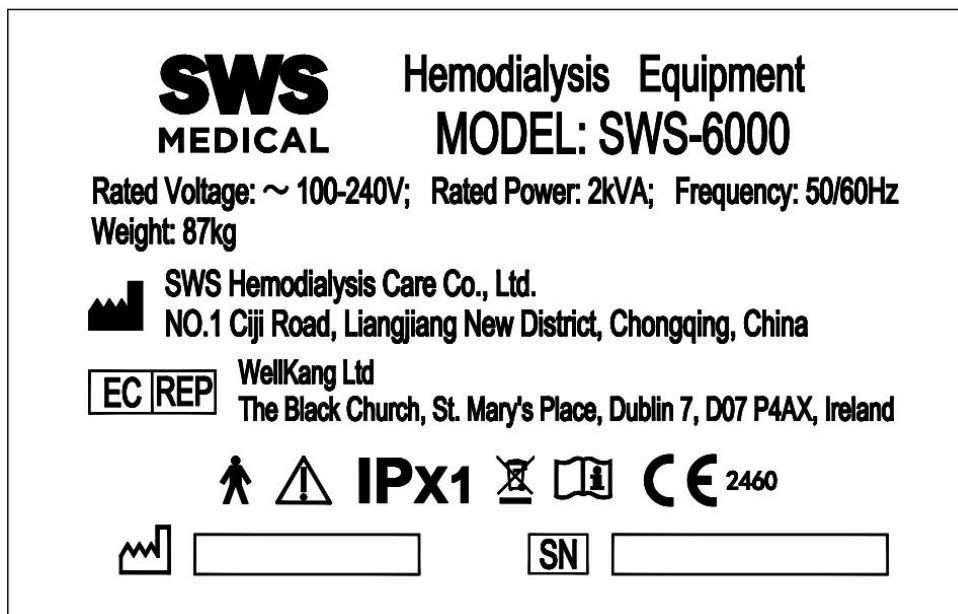

Pic. 11-1 Model: SWS-6000

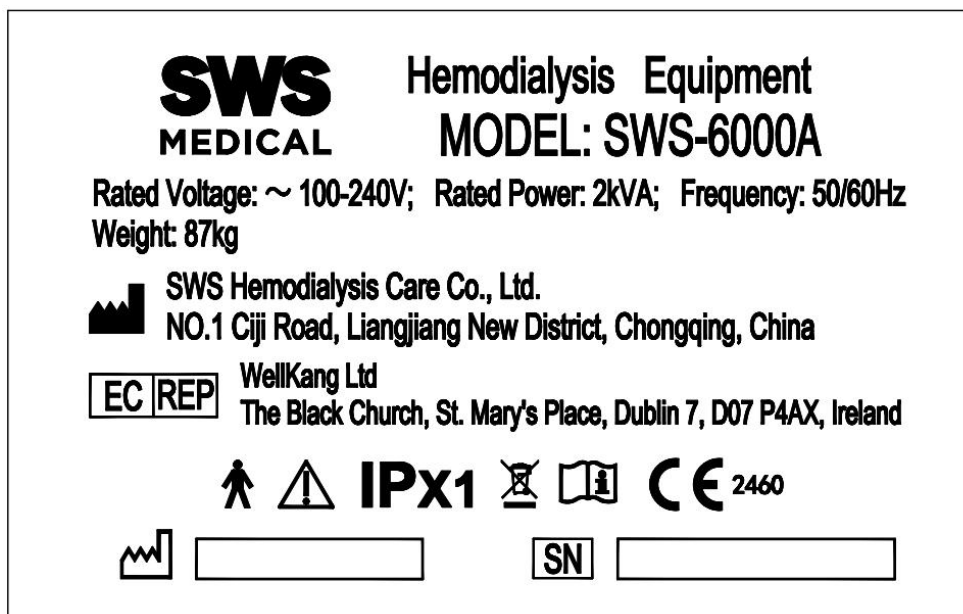

Pic. 11-2 Model: SWS-6000A

### 11.1.4 Product Quality Certificate

Manufacture Name, Product name, Quality inspection date, QC number.

## 11.2 Packaging

- The equipment and the attachment should be packaged with the neutral paper or

plastic membrane material.

- Wooden case is adopted for the package of equipment. Device like rain protection and soft pad should be inside the case. Install slide wood at the bottom of the case.
- The package list, certificate of inspection, instruction manual, spare parts and documents should be in the case.

### **11.3 Environmental condition during delivery and storage**

- Execute drainage procedure if stored more than 1 month and keep no liquid.
- Environmental temperature : -20°C ~ 60°C.
- Environmental relative humidity:10% ~ 93%.
- Atmospheric pressure range: 50 kPa ~ 106 kPa
- The product under good package should be stored in the dry and well-ventilated room without corrosive gas.
- Inspection and experiment.
  - The work should be done by the professional person, if operate by mistake it will cause the fire and abnormal movement and would not work normally the next time .
  - Before reuse, do rinse of disinfection.
  - After rinse is finished, cleaning for one hour according to the sequence of disinfection, decalcification and ferric ion removal.
  - Ensure no water leakage, no abnormal sound and no disgusting smell. Buttons on the control panel perform well.

Confirm there is no disinfection left when completing clean, confirm the ultrafiltration precision and conductivity without abnormality.

# 12 Electrical Principle Diagram

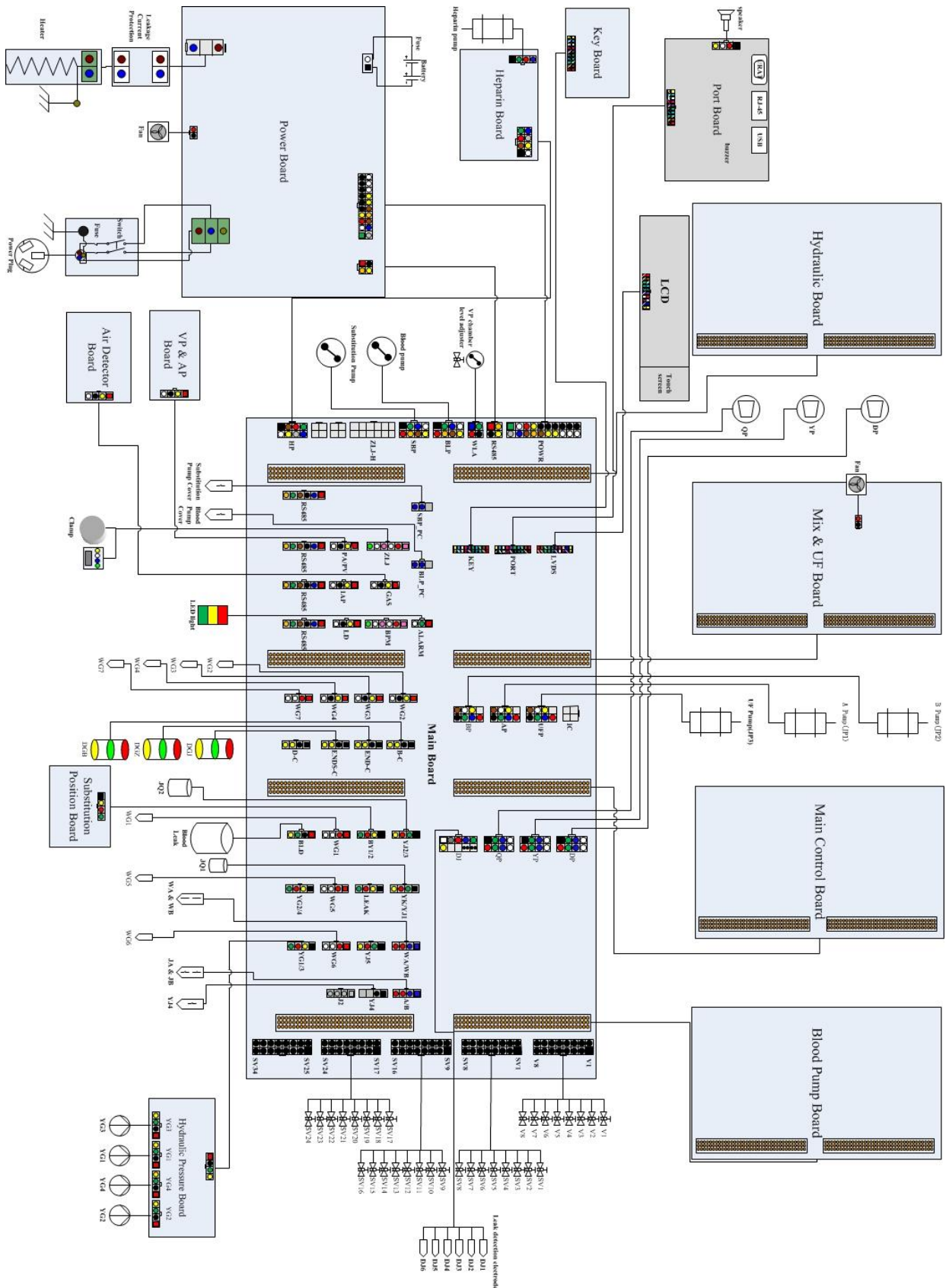

## 12.1 Power

Table 12-1

Item	Specification
Voltage	~100-240V
Frequency	50/60Hz
Wire	3 core, cross-sectional area 1.5mm <sup>2</sup> , length 3m
Fuse	15A/250V, size $\phi$ 6.3mm× 32mm
Power consumption	Less than 2000VA

## 12.2 Inlet and outlet pipeline

Inner diameter 10mm.

# 13 Appendix

## 13.1 Quality guarantee

- Manufacturer will take responsibility for the failure which caused by the manufacture artwork and material.
- Stop to operate the product when the failure arise, please contact with us.
- Analysis and judge the failure processed by the manufacture.
- When the product with failure, please contact our sales–service center. If disassemble the equipment by yourself, we do not unertake the responsibility for the equipment.
- The warranty of the product is one year. The equipment can be changed if failures that are caused by quality problem occur within three months. The equipment only can be repaired exceeding three months.
- Within warranty, the equipment will not be repaired if incorrect use of instruction manual, disassembling equipment by yourself or man-made destruction. If necessary, charge spares parts fee and maintenance expense.
- During life cycle and one year after purchasing, the equipment is repaired by manufacturer and the related spare parts are provided. Charge the cost for spare parts and maintenance expense.
- The expected service life of the equipment is 25000 hours, and we provide on-site maintenance during 48 hours.
- Regular maintenance will be done by manufacturer or user maintenance department as required after the product has been used for one or two years.

## 13.2 Manufacturer information



SWS Hemodialysis Care Co., Ltd.

Address: No.1 Ciji road, Liang jiang new district, Chongqing, China

Tel: +86-23-68884702

Email: sales@swskj.com

Web: www.swskj.com

## European authorized representative

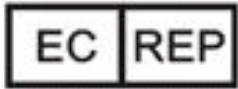

WellKang Ltd

Company address: The Black Church, St. Mary's Place, Dublin 7, D07 P4AX, Ireland

Ph 1: +44(20)3287 6300

Ph 2: +44(33)3303 1126

Fax: +44(20)76811874

Website: www.CE-marking.com