



Blood Bank Refrigerators  
Thrombocyte Incubator / Thrombocyte Agitator  
Laboratory / Plasma Freezer  
Plasma Thawer  
Laboratory / Pharmacy / Vaccine Refrigerator  
Solar Direct Drive Vaccine Refrigerator  
(Ice-lined Thermal Storage Technology)  
Mains Powered Vaccine Refrigerator  
(Ice-lined Thermal Storage Technology)  
Combined Refrigerator + Freezer  
12-24 V In-Car Mobile / Power Unit Refrigerator  
Incubator  
Newborn Product Group  
Fluid and Blanket Warming Cabinet  
Dry Oven Sterilizer (Etuves) / Water Baths  
Cooled Incubator  
Stability Test Chamber  
BOD Incubators

Since 1975...

**EMSAS**®

# LABORATORY AND PHARMACY REFRIGERATORS

## EKT Serie (+0°C/+15°C)

- Temperature range: 0°C to +15°C (factory set to +4°C)
- Microprocessor-controlled digital panel with 30-day data storage and password protection.
- USB data logging system: stores temperature data for up to 10 years and enables export to PC in Excel format.
- High-precision temperature control with  $\pm 0.1^\circ\text{C}$  accuracy.
- Inner chamber made of AISI 304 stainless steel.
- Double-layer glass doors, lockable, with magnetic gaskets.
- Adjustable plastic-coated wire shelves.
- Multi-airflow system ensuring uniform temperature distribution.
- Fin-type evaporator cooling system with automatic defrost.
- Built-in rechargeable battery system supporting control panel and printer for up to 48 hours during power failure.
- Visual and audible alarm system activated in case of:
  - Temperature deviation (high/low limits)
  - Door open condition
  - Power failure
  - Sensor failure
- Remote alarm output port.
- External sensor input port.
- Equipped with 2 lockable and 2 swivel casters.
- Silent and vibration-free operation.
- LED interior lighting system.
- Optional block solid door version available.
- Optional vaccine monitoring system.
- 2-year warranty.
- Certified according to ISO 9001:2015, ISO 13485, TSE, CE, ISO 14001



### STANDARD

- Multi Air-Flow System
- CR-NI 304 Stainless Steel Inner Surface
- Digital Control Panel with Microprocessor
- 2 Braked and 2 Swivel Casters
- Alarmed Electronic Control System
- Reporting via USB Memory



### OPTIONAL

- Solid Door
- Thermal Printer
- Circular Chart Recorder
- Vaccine Tracking System
- Password-Protected Digital Touch Control Panel
- Chrome Shelf

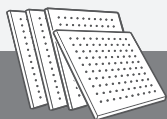

Optional  
Chrome Shelf



Vaccine  
Tracking System





[www.emsas-as.com.tr](http://www.emsas-as.com.tr)  
[www.kandolabi.com](http://www.kandolabi.com)  
[www.asidolabi.com](http://www.asidolabi.com)  
ISO 9001:2008  
ISO 13485



Contact



Promotional Film



Product Introduction  
Videos



Muradiye Sanayi Bölgesi Muradiye Mahallesi  
28 Sokak No:6 Yunusemre - MANİSA / TURKEY  
Tel: +90 (236) 214 03 96 - 97 - 98 Fax: +90 (236) 214 07 06  
İzmir Tel: +90 (232) 479 55 22 - 479 55 23  
mail: [info@emsas-as.com.tr](mailto:info@emsas-as.com.tr)



# **EKT SERIES PHARMACY REFRIGERATOR**

## **MANUAL BOOK**

**Emsaş Elektrik Malzemeleri San. Tic. A.Ş Muradiye Sanayi  
Bölgesi. 28 Sokak No:6 Yunusemre -MANİSA**

Tlf: 0 236 214 03 96-97-98 Fax: 0 236 214 07 06

[www.emsas-as.com.tr](http://www.emsas-as.com.tr)

## **GENERAL INFORMATION**

Please read the manual book carefully and keep the book for forward before using your device.

If there can be any defect contact with the shipping company to the report damage. According to ICC regulations, the responsibility belongs to the consumer.

When operating the device;

1. Follow the warning labels
2. Do not remove the labels
3. Do not operate the damaged device
4. Do not operate the device with a damaged cable system.
5. Do not move the device while the device operating.

- \* In case of any problem please contact with EMSAŞ A.Ş technical service.
- \* Read the manual book carefully before using the device, this ensures you to get high efficiency.
- \* The EMSAŞ A.Ş has the right of changing and developing the device structure.
- \* Please keep the product package until be sure the device is full, complete, and correct.
  - \* The warranty is valid until the precautions described in this manual are followed.

***Informations in this document belongs to EMSAŞ A.Ş  
It can not be reproduced or distributed without any permission.***

## **WARRANTY CONDITIONS**

1. The warranty period starts from the delivery date of the goods and is two years.
2. The entire product, including all parts, is under our company's warranty.
3. In case of malfunction of the product within the warranty period, the period of repair is added to the warranty period. The repair period of the goods is maximum of thirty working days. This period starts from the date of notification of the goods to the service station. In case there is no service station, respectively; it starts from the date of notification to one of the seller, dealer, agency, representative, importer or manufacturer of the goods. If the defect of the industrial goods cannot be fixed within 15 working days, the manufacturer or the importer; it has to allocate another industrial good with similar characteristics to the use of the consumer until the repair of the good is completed.
4. If the product fails during the warranty period due to material and workmanship or assembly errors, it will be repaired without any charge under any other name, such as labor cost, replacement part price, or any other name.
5. Despite the consumer's use of the right to repair, the goods;
  - The fact that the same fault is repeated more than twice within a year from the date of delivery to the consumer, or that different faults occur more than four times, or that the sum of different faults is more than six within the specified warranty period, and that these faults perpetuate the inability to benefit from the goods,
  - Exceeding the maximum time required for repair,
  - In cases where it is determined that the repair of the fault is not possible with the report to be issued by the company's service station, if the service station is not available, respectively, one of the dealers, agents, representatives, importers, or manufacturers, the consumer may request a free replacement of the goods, a refund or a price reduction at the rate of the defect.
6. Defects arising from the use of the product contrary to the terms in the user manual are not covered by the warranty.
7. For problems that may arise regarding the warranty certificate, the Ministry of Industry and Trade, General Directorate of Protection of Consumer and Competition can be applied.

## **CUSTOMER MATTERS REGARDING THE WARRANTY**

Issues that our customers should pay attention to regarding the warranty

1. Malfunctions arising from the use of the device other than its normal use,
2. Defects arising from exposure to substances with physical or chemical effects,
3. Damages and malfunctions that occur in case of non-compliance with the points in the user manual,

4. Damages due to lower excess voltage faulty installation or using a voltage different from the voltage written on the label of the device,
5. Damages that will occur during loading, unloading, and transportation under the responsibility of the customer,
6. The device has been disassembled for various reasons or its functions have been changed by people other than service officials,
7. Malfunctions and damages that may occur due to fire and lightning,
8. Responsibility for the completion of the warranty certificate and the delivery to the consumer belongs to the seller, dealer, agency, or representative office from which the consumer purchased the goods,
9. This warranty is void if the warranty document has been tampered with, the original serial number on the product has been removed or tampered with.

***THIS MANUAL MUST BE READ CAREFULLY BEFORE OPERATING THE DEVICE.***

***WARRANTY CONDITIONS APPLY IF THE INSTRUCTIONS AND WARNINGS DESCRIBED IN THE DEVICE'S USER MANUAL ARE COMPLIED.***

***THE INFORMATION CONTAINED IN THIS MANUAL BELONGS TO EMSAS. THE INFORMATION IN THE MANUAL CANNOT BE REDUCED OR DISTRIBUTED WITHOUT EMSAS' PERMISSION.***

In the above-mentioned cases, troubleshooting is done for a fee.

The product's installation and transportation to the place of use are not included in the product price.

\* The useful life of the goods announced by the Ministry of Industry and Trade in accordance with the Law on the Protection of the Consumer No. 4077 is 10 years.



## **TABLE OF CONTENTS**

- 1. DESCRIPTION OF DEVICE, FUNCTION, AND OPERATING PRINCIPLE**
- 2. TECHNICAL SPECIFICATIONS**
  - 2.1. Technical Specifications Table
  - 2.2. Technical Specifications Description
- 3. INSTALLING THE DEVICE**
  - 3.1. Environmental Conditions
  - 3.2. Handling and Shipping
  - 3.3. Unpacking
  - 3.4. Determination and Placement of Settlement
- 4. INSTRUCTIONS FOR USE**
  - 4.1. Device Operation
  - 4.2. Introduction Image
  - 4.3. Control Display Panel and its Functions
  - 4.4. Electronic Wiring Diagram
- 5. CLEANING AND MAINTENANCE**
  - 5.1. Maintenance
  - 5.2. Cleaning
- 6. SAFETY**
- 7. DISPOSAL(battery, compressor, mainboard and etc.)**
- 8. WARNINGS & PRECAUTIONS**
- 9. MEANING OF SYMBOLS**
  - 9.1. Meaning of Symbols on Top of the Device
- 10. SERVICE**
  - 10.1. Troubleshooting Table
- 11. SPARE PARTS & ACCESSORIES**
  - 11.1. SPARE PARTS
  - 11.2. ACCESSORIES

## 1. INTRODUCTION

### 1.1. DESCRIPTION OF DEVICE, FUNCTION, AND OPERATING PRINCIPLE

Products such as vaccines, kits, drugs and serums are designed to be used in hospitals, laboratories, pharmacies, health inspection centers and departments where products such as drugs, kits and serum are stored.

Cabinets with a cooling system that allows them to be stored at 0°C / +15°C for up to 12 months are called "Kit Storage Cabinets".

#### **PURPOSE:**

In all health centers, products such as vaccines, medical kits, drugs and serums are at temperatures between 0°C / +15°C.

It is to be kept at +4 °C for up to 12 months. Our kit storage cabinets are designed to serve for many years in health centers.

#### **WORKING PRINCIPLES:**

The device is designed to control temperatures in the range of 0°C / +15°C.

All of our cabinets in the EKT series can be adjusted to the desired temperature between 0°C / +15°C.

However, the factory set value is +4°C.

The cooling system in our EKT series cabinets works with the on/off (open / close) principle.

In all our EKT series cabinets, air circulation is provided with the help of a fan in order to ensure equal heat distribution in the inner cabinet.

Microprocessor-controlled electronic cards are used in our devices.

CFC-free polyurethane foam insulation material is used so that the device can maintain the temperature in the interior for a longer period of time.

Our EKT series cabinets are divided into 5 main groups:

**EKT Series:** Double Glass Door Model.

**EKT-A Series:** Double Glass Door & Simple Card Model

**EKT-B Series:** Block Door Model

**EKT-AB Series:** Block Door & Simple Card Model

**EKT VK Series:** Thermal Printer Model

#### **Matters to be considered by the User During Use:**

- When putting blood bags in your cooler, do not stack products in the cabinet in a way that prevents air circulation. This will cause unwanted temperature differences in the upper and lower parts of your cooler.
- There is 1 sensor in the blood storage cabinets that measures the temperature inside the cabin. On the electronic card, this temperature is reflected on the screen and shown to the user.
- After starting your cooler, it can give an alarm visually and audibly until it reaches the ideal operating temperature on the digital display. When the cooler reaches the ideal temperature (between 0°C and +15°C), the visual and audible alarm will stop. After that, you can load your cabinet.

#### **External Probe Input;**

The plug on the right side of the cabinet is removed and the probe is placed (If the thickness of the probe is high, the plastic can be expanded.) Take care that the inserted probe tip is inserted into the cabinet and fixed next to the sensor inside the cabinet.



## 2.2 Technical Specifications Description

- The outer surface of the device is made of corrosion-resistant electrostatic painted galvanized sheet material, and the inner surface is made of chrome-nickel alloy sheet material.
- The device is 195-230 V/50 Hz. It works with mains voltage.
- The door of the device is double glazed, lockable and magnetically sealed. In this way, it allows stock tracking.
- Inside of the device there is a user arrangeable plastic coated shelf. The device works in the range of 0°C / +15°C, which is the ideal storage temperature of products such as kits, vaccines, drugs, and serum, and can be adjusted to +4°C.
- Equal heat distribution is provided in the cabinet with the reinforced fan system in the cabinet.
- The device works silently and smoothly without separating kits components.
- The device has full automatic defrost system for protecting evaporators efficient work.
- Cabinet interior lightning realized with LED lighting module.
- Eco friendly microprocessor controlled panel is used in our device.
- The device has a USB port that enables the transfer of temperature information to the computer environment at any time.
- The thermostat in the cabinet control panel can measure with an accuracy of 0.1°C.
- The device has a sensor for measuring the cabin temperature inside.
- In control panel there is a accumulator system that can be charged automatically. In case of a electricity cut this system ensures that the digital control panel and thermal printer continue to work for 24 hour long.
- The device gives an audio and visual warning signal when the device's doors open, in power cut, when the upper and lower limits are exceeded, and low voltage situations while the device working.
- The insulation material does not include CFC that harmful for environment and ozon layer.
- 2 pieces of braked and 2 pieces of regular castors are used at the bottom of our EKT series devices, except EKT 80, EKT 80 include 4 pieces of ball joint.
- All medical devices produce by Emsaş A.Ş are guaranteed by 2 years.
- As per the request of the user, a thermal printer can be installed at the device. The numerical and graphical printout of the data recorded with the thermal printer can be taken.
- All of our products are produced in accordance with ISO 9001:2008, TSE service place qualification requirements. Our blood cabinets that we have produced have CE, UBB registration and barcode.

### OPTIONAL FEATURES:

**USB MEMORY:** Electronic card system can be sent as USB memory upon user request. Up to 10 years, degrees can be stored and transferred to the computer environment. The transfer is provided in excel format.

**VK (THERMAL PRINTER SYSTEM):** The thermal printer system can be optionally attached to our devices. It can give output at intervals between 5 minutes and 60 minutes. It has the feature of printing the temperature of the device inside the cabinet on paper.

**MAINBOARD WITHOUT USB MEMORY:** In line with the user's request and requirement, a card that does not keep the temperature in the cabinet in its memory can also be inserted.

## 3. INSTALLING THE DEVICE

### 3.1. Environmental Conditions

Your device works efficiently under the following environmental conditions:

- Using only indoor area
- Storage and Transportation conditions: +25°C / +45°C
- Relative Humidity: %65
- Temperature Values: 0°C / +15°C
- Maximum Altitude: 2000 meter
- Temperature range for maximum performance: 15°C / 20°C

### **3.2. Handling and Shipping**

- Because of, the device weight all the shipping should apply with the proper equipment and experienced staff.
- During transportation it must be supported from underneath and must not be turned upside down.
- Interior hardware (shelf rails, supports, wire shelves, drawers) is shipped inside the unit. The device is fixed to a wooden base by means of screws or packaged with cardboard, Styrofoam, and burst nylon.

### **3.3. Unpacking**

- Open the device cardboard package.
- Remove the stretch and styrofoam, which is the second packaging on the device.
- Remove the wooden base
- Check is there any transportation damage on the device with eye.
- If is there any transportation damage firstly take a picture of damage and secondly Inform the transport company officer to keep a report.

### **3.4. Determination and Placement of Settlement**

- Check that the placement spot is suitable
- Avoid direct sunlight and heat sources
- Remove the accessory from the unit
- Care should be taken to carry the device vertically during the relocation phase and during the transport phase. Otherwise, the device will not work or will not work properly and cannot be used because the balance of the device will be disturbed.
- Check that the ambient temperature where the device is installed is between 15°C and 20°C. Otherwise, the cooling performance of your device will decrease.
- Installation should be on flat ground and with four legs. Otherwise, it may not work properly.
- The placement of the device shall not be wet or damp. Otherwise, it can cause damage to devices electrical systems.
- The device shall not be close to any other dissipate heat device. Otherwise, it can cause damage to devices electrical systems.
- Check that the user has the opportunity to monitor the device if he/she does other work.
- When placing your device, you should pay attention to the fact that there must be a minimum of 10 cm space between the side, back and top surfaces and the place to be placed, and 20 cm from the top. There should be no plates behind the device that may cause evaporation.
- The hose in the compressor compartment of your cooler; for evacuation of dripping water during defrosting. Before operating the cabinet, be sure to check whether there is water in the hose in the container.
- When your device needs to be moved or relocated, have it done through the service channel if necessary.

## **4. INSTRUCTIONS FOR USE**

### **4.1 Device Operation**

- Plug the device in (grounded plug)
- Press the on/off switch, enter the password and turn on the device.
- The operating range of the device is between 0°C ve +15°C.
- Before operating your device, have technical personnel (electrician) check whether the socket to be used is grounded or not and the mains voltage. Do not operate if it is not grounded.
- Wait before operating your device at least 45 minutes after unpacking your device. This will prevent the compressor of your cooler from being damaged.
- Service representative at first start-up; Information about the device; technical personnel and health personnel (nurse - Dr) of the relevant customer should transfer.

## 4.2 Introduction Image



**PIC1. EKT Pharmacy Refrigerator**

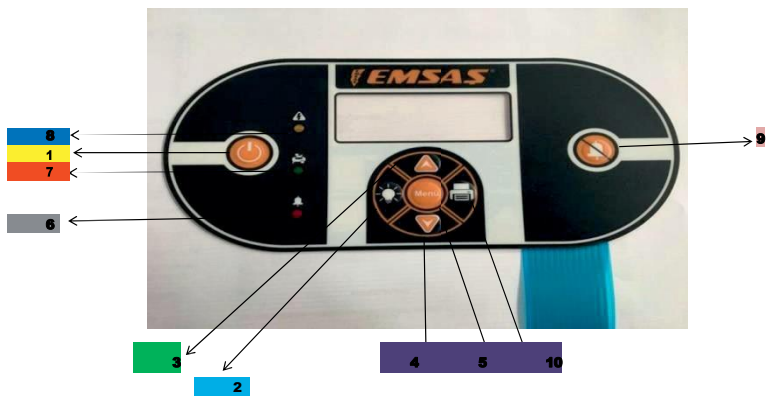

DISPLAY BUTTONS	1		ON/OFF BUTTONS
	2		LIGHT ON/OFF BUTTONS
	3		UP ADJUSTMENT BUTTON
	4		MENU AND SETTINGS BUTTON
	5		DOWN ADJUSTMENT BUTTON
DIGITAL DISPLAY BUTTONS	6		RED LIGHT ( LCD DISPLAY)
	7		GREEN LIGHT(WHEN COMPRESSOR IS ON)
	8		YELLOW LIGHT (POWER LIGHT)
	9		ALARM SILENCE BUTTON
	10		PRINTER BUTTON

1		ENTER BUTTON
2		UPPER ADJUSTMENT BUTTON
3		LOWER ADJUSTMENT BUTTON

## Factory Output Settings

### EKT SERIES

- |                                  |             |
|----------------------------------|-------------|
| 1) Operating Temperature Range   | : 0 / +15°C |
| 2) Set Temperature Value         | : +4°C      |
| 4) Compressor Delay Time         | : 30 sec.   |
| 5) Door Open Alarm Waiting Time  | : 2 min     |
| 6) Alarm Silence Time            | : 30 sec.   |
| 7) Thermal Printer Printing Time | : 8 hour    |

### Set Parameters

By pressing the SET Button, the parameter entry screen is accessed. There are 3 separate passwords, these passwords have separate functions.

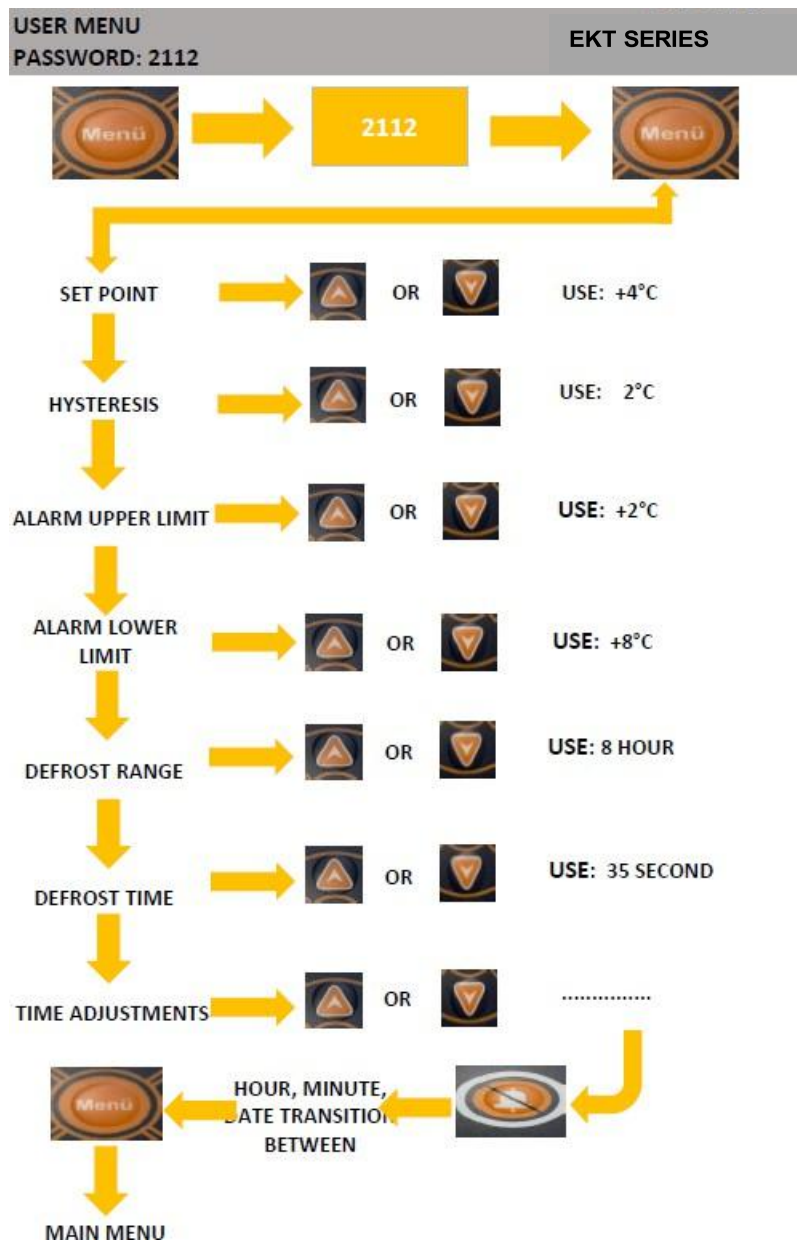



CALIBRATION MENU  
PASSWORD: 3113

EKT SERIES

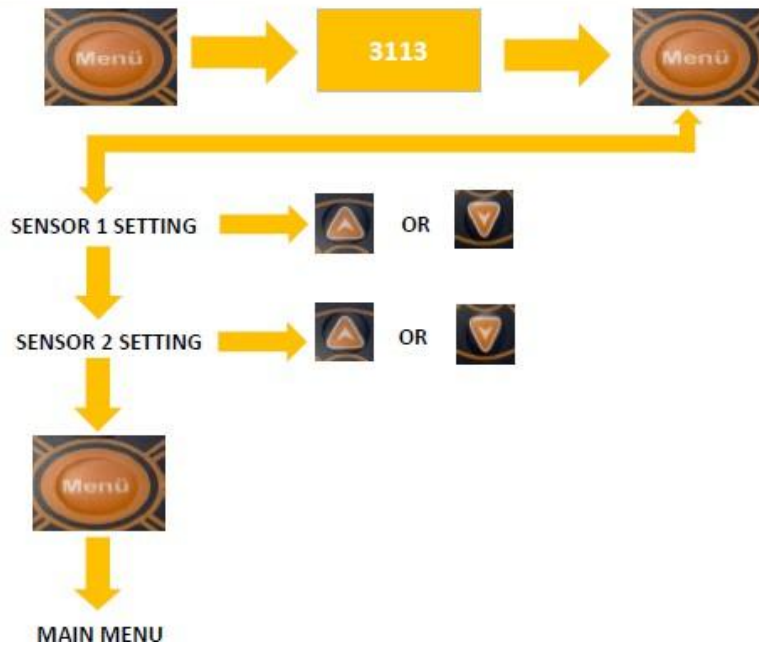

**PIC3. Control Panel Without USB Port**



1		ENTER BUTTON
2		UPPER ADJUSTMENT BUTTON
3		LOWER ADJUSTMENT BUTTON

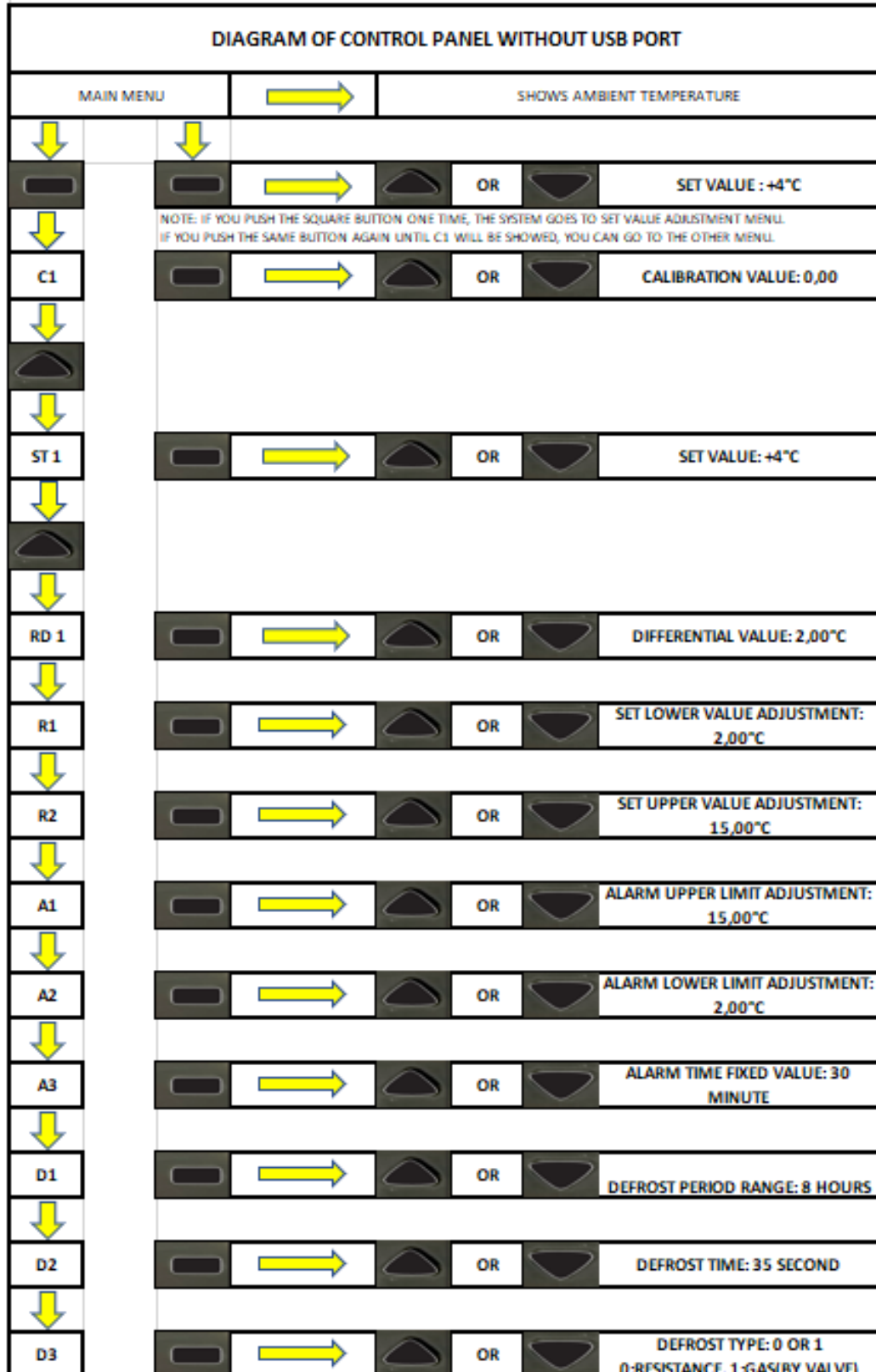

NOTE: IF YOU PUSH THE SQUARE BUTTON ONE TIME, THE SYSTEM GOES TO SET VALUE ADJUSTMENT MENU.  
IF YOU PUSH THE SAME BUTTON AGAIN UNTIL C1 WILL BE SHOWED, YOU CAN GO TO THE OTHER MENU.

## 4.3 Electronic Wiring Diagram

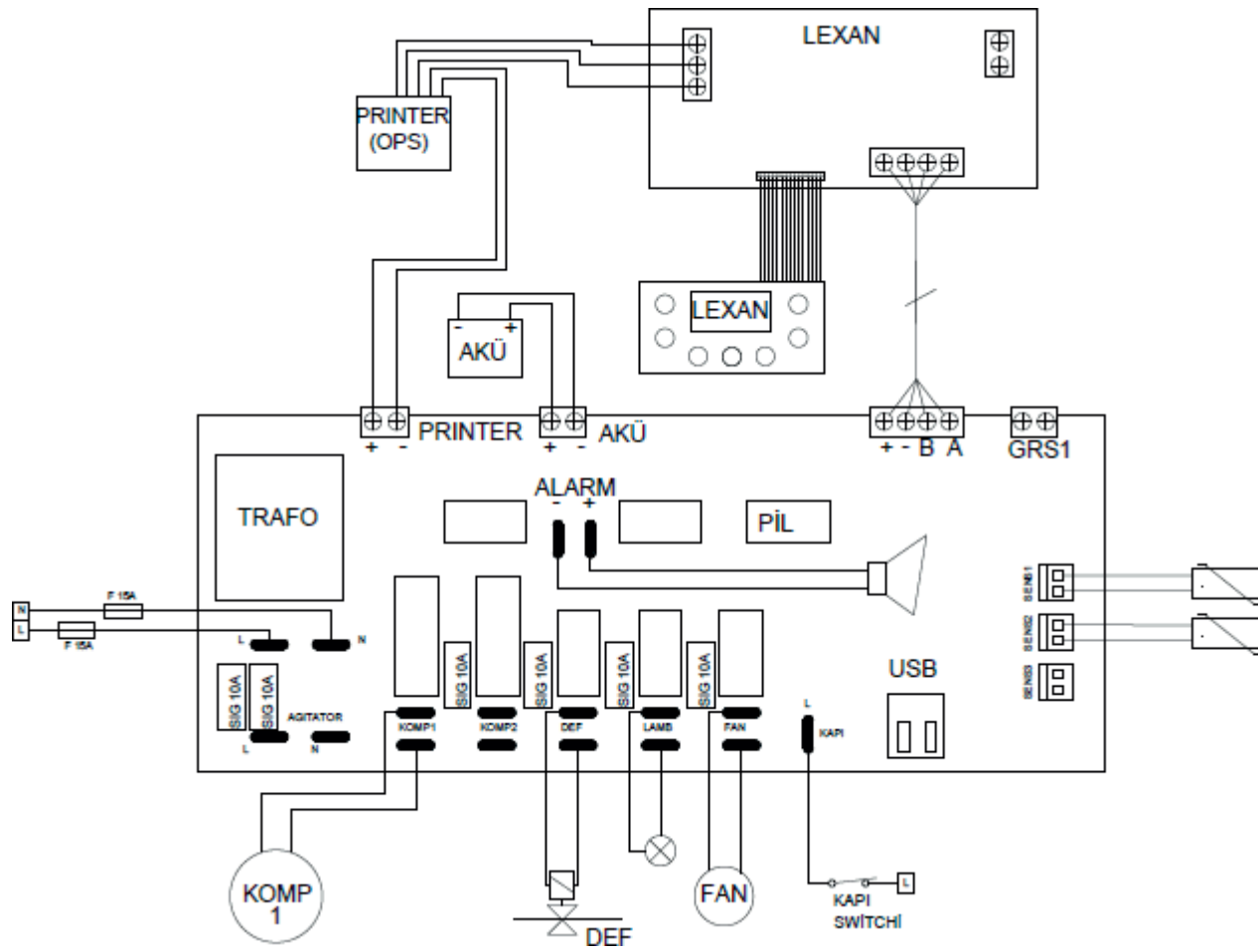

## 5. CLEANING AND MAINTENANCE

### 5.1 Maintenance:

Periodic maintenance should be carried out once a month depending on the ambient conditions in which the device is located, and once every 6 months under normal conditions.

### 5.2 Cleaning

- The device is cleaned in our factory before delivery to the customer.
- Clean the device at ambient temperature after disconnecting the power cable from the device.
- Wipe your device with a damp and dry cloth against dirt and dust. Finally, plug in your cabinet and start it from the on-off button.
- Depending on the environmental conditions of your Medical Device, clean it regularly once a month or once every 6 months.
- In order to clean the condenser of your device, it is necessary to clean it from dust first.
- The condenser compartment of your device should be cleaned by a technical personnel with a vacuum cleaner or a soft paint brush, and the electrical components should not be damaged.
- Clean the condenser under your device with a damp cloth at least once every 4 months by pulling out the electrical outlet.

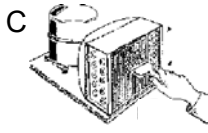

- The glass doors can clean with proper glass cleaner.
- Do not clean the engine compartment of your cooler with water, etc. It will damage the electrical components of your water closet and the user may be exposed to electric shocks.
- Wipe the plastic drainage bowl next to the compressor, where the defrosting water reaches, with a damp cloth.
- Do not use abrasive and purifying chemicals while cleaning inside and outside your cooler with a damp cloth, it can cause damage. Faults and errors that may arise from this reason will be treated out of warranty.

## 6. SAFETY

- Before doing cleaning and maintenance please review and read your safety instructions.
- If the device needs to be relocated or moved for maintenance, be sure to check the brakes of the wheels. Otherwise, the wheels may be damaged and broken. In this case, the balance of your device may deteriorate and may not work efficiently.
- Do not touch the unit with wet hand and/or feet
- Do not insert screwdrivers or other pointed objects between the moving parts of the device.
- The device cannot use by an unauthorized person.
- Before doing any kind of cleaning or maintenance operations please cut the electricity.
- Disconnect the main switch from the switching power before unplugging the appliance when cleaning or maintaining the appliance.
- Check that the device placed where it will be used is on flat ground and with four legs. It's dangerous to do any repair or service operations about device by unauthorized persons.
- When your device plug in do not any kind of maintenance and reparation.
- We strongly recommend you to use a voltage regulator in order not to damage the compressor in places where there may be larger changes.
- Do use your device according to the principles of the user manual.
- When you have a service request regarding your product, please contact our Service Center at the phone numbers above.

## 7. DISPOSAL

The user is responsible for the proper disposal of each part as waste. Electronic parts used, except power and current sources, should be disposed of according to the rules specified for the waste of electronic devices. When the product is to be disposed of, hospital, laboratory and national legislation should be followed.

## 8. WARNINGS & PRECAUTIONS

- Do not use the device out of usage aim
- The device should operate after reading the manual book by authorized and educated personnel. In case of any problem, only authorized personnel can interfere to the device.
- The voltage in the electrical network must be suitable for the power of the device and must be grounded.
- Only spare parts and accessories provided by Emsaş A.Ş should be used.
- There should be no substances in the usable volume that may be affected by the operating temperature of the device and damage the device.
- We strongly recommend you to use a voltage regulator in order not to damage the compressor in places where there may be larger changes.
- When putting the vaccines in your device, do not stack them on the back to prevent air circulation. This will cause unwanted temperature differences in the upper and lower parts of your cooler.
- After operating your cooler, your cooler can give audible and visual alarms until it reaches the ideal operating temperature(0°C/+15°C). when your cooler reaches ideal operating temperature, the alarms shuts down. Then you can load the products.
- When you receive your product confirm the warranty certificate your authorized dealer.

## 9. MEANING OF SYMBOLS

### 9.1. Meaning of Symbols on top of the Device



**CE Certificate**



**Manufacturer Name and Address**



**Date of Manufacture**

Indicates the date of manufacture of the medical device.



**Catalog Number**

Indicates the manufacturer's catalog number by which the medical device can be identified.



**Serial Number**

Indicates the manufacturer's serial number by which a particular medical device can be identified.



**Fragile**

Indicates that a medical device may break or be damaged if not handled carefully. It is located on the parcel.



**Keep away from the sun.**



**Protect from heat and radioactive sources.**

The device is affected by heat. For this reason, the device must be protected from heat sources.



**Protect from moisture. Located on the parcel.**



**Storage conditions: 20°C / 45°C**



**Usage Instruction**

A synonym for "refers to using instructions" is "refer to operating instructions".



This symbol draws attention to safety warnings and potentially dangerous situations. Failure to follow these warnings could result in damage to the device and injury to users.



Indicates that the user should refer to the instructions for use for important warning information such as warnings and precautions that cannot be presented on the medical device for many reasons.



**Grounded Socket**

Operate in a place with protective grounding



**Alternative Current**



**Dangerous Voltage!**

It is a symbol indicating the current available on the device. The place where there is electricity is also the symbol that should be specified.



**Do not touch!**



**Do not touch with wet hand and/or feet!**



Keep Upright. It is located on the parcel.

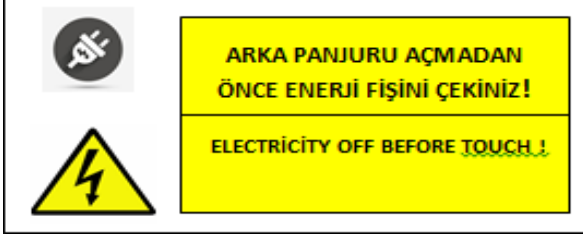

## 10. SERVICE

Your device can give audible and visual alarms in first operation. In case of this situation press the alarm silent button located on the display

Do not allow the repair of the device to anyone other than the authorized service during the warranty period. In case of interventions other than authorized service, the device will be subject to operation out of warranty.

When you encounter a problem with the device, call the authorized service or Emsaş numbers that made the first installation.



## 10.1 Troubleshooting Table

FAULT	CAUSE /CORRECTION
<b>THE COOLER DOES NOT WORKING THERE IS NO ELECTRICITY</b>	<ul style="list-style-type: none"> <li>*Make sure it is plugged in.</li> <li>*Make sure there is electricity in the mains.</li> <li>*If there is voltage outside the tolerances given in the network, the device it doesn't work.</li> <li>*Make sure the power button is on.</li> </ul>
<b>LIGHT IS NOT WORKING WHEN THE DOOR OPEN</b>	<ul style="list-style-type: none"> <li>* The lamp can be broken or it may have moved from the lamp socket. If its broken inform the service</li> <li>* The lamp switch may be damaged. Inform the service</li> </ul>
<b>THE TEMPERATURE DISTRIBUTION IN THE CABINET IS NOT HOMOGENEOUS ENOUGH, THE TOP AND BOTTOM ARE AT SEPARATE TEMPERATURES.</b>	<ul style="list-style-type: none"> <li>* Material may have been placed in front of the indoor fan. For better air circulation materials should not be placed in front of the fan.</li> <li>* The inner fan may be damaged, inform the service.</li> <li>* The fan switch may be damaged, inform the service.</li> </ul>
<b>THE DEVICE IS NOT COOLING</b>	<ul style="list-style-type: none"> <li>* Keep condenser clean. Do control fan in the back is working or not</li> <li>* If the fan is not working, inform the service</li> <li>* If the fan is working and the cabinet is not getting cold, inform the service</li> </ul>
<b>THE PRINTER IS NOT WORKING</b>	Check the battery current. If the battery is 12V low, the battery is replaced or charged in a separate place. The paper is checked.
<b>THE DEVICE MAKE NOISE</b>	Check the battery voltage. If it is less than 10V, replace the battery and charge it separately. Check the printer settings as described in Chapter "Troubleshooting".
<b>BATTERY IS NOT WORKING/ COMPRESSOR IS NOT WORKING</b>	Do call your authorized service immediately

## 11. SPARE PARTS & ACCESSORIES

### 11.1 Spare Parts

There are no spare parts on the device that you can replace. Please notify our authorized service in case of malfunction.

### 11.2 Accessories

Warranty Certificate and Manual Book.

2 pieces shelves for EKT 80 model

2 pieces shelves for EKT 150 model

3 pieces shelves for EKT 175 model

4 pieces shelves for EKT 250 model

5 pieces shelves for EKT 425 and EKT 725

model

12 pieces shelves for EKT 1450 model

There is no other accessories than these

## **Contact**

For any service request or training or questions about your device please use this guide [kalite@emsas-as.com.tr](mailto:kalite@emsas-as.com.tr).

For general information use [info@emsas-as.com.tr](mailto:info@emsas-as.com.tr) or to see <http://www.emsas-as.com.tr>