

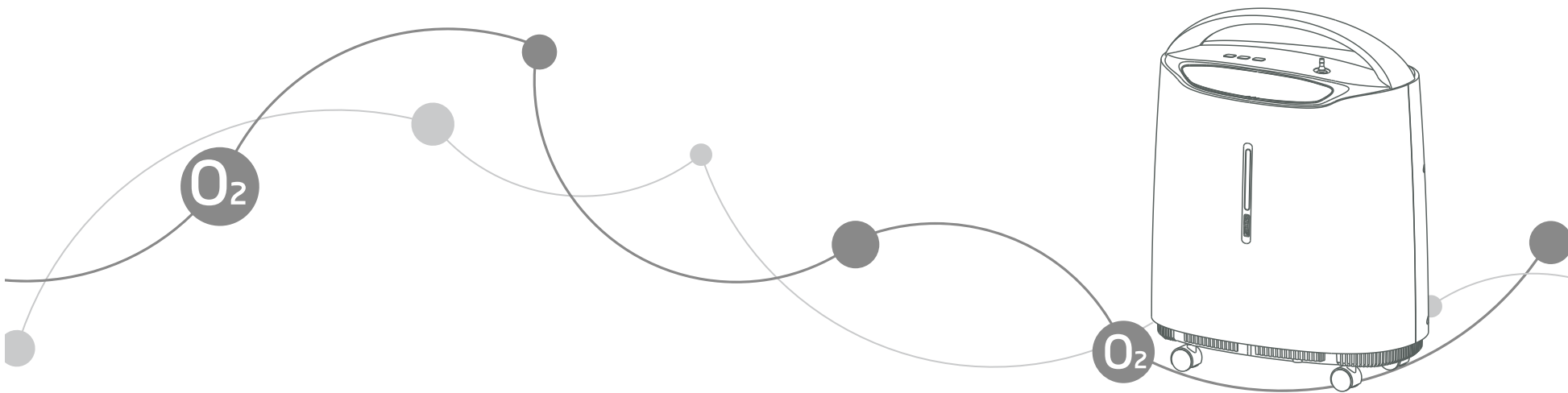

yuwell



8F-5A Oxygen Concentrator

User's Manual

JIANGSU YUYUE MEDICAL EQUIPMENT & SUPPLY CO., LTD.
Sales Center Address: Huanyuan East Road No.1, Xuzhuang Software
Park, Nanjing, Jiangsu Province, P.R. China, 210000
Manufacturing Address: YunYang Industrial Park, DanYang, Jiangsu
Province, P.R. China, 212300
<http://www.yuwell.com>

A131039-1A 

Do not operate this unit without first
reading and understanding this manual

SAFETY NOTES

TABLE OF CONTENTS

SAFETYNOTES.....	1-4
FEATURES.....	5-7
HANDLING.....	8-8
OPERATING & INSTALLATION.....	9-15
MAINTENANCE.....	16-17
TROUBLESHOOTING.....	18-20
OTHER ATTENTIONITEMS.....	21-22

WARNING: INDICATION FOR USE

For avoiding power outage or oxygen concentrator operating failure, exigent oxygen user and serious patient must equip with reserve oxygen supply (for example: oxygen cylinder, oxygen bag). This device is to be used as an oxygen supplement. It is not used as life supporting or life sustaining.

WARNING: CONTRAINDICATIONS

The oxygen concentrator is not intended for life supporting or life sustaining applications, nor does it provide any patient monitoring capabilities.

Symbol	Description
⚠ WARNING	Describes a hazard or unsafe practice that if not avoided can result in severe bodily injury, death or property damage.
⚠ CAUTION	Describes a hazard or unsafe practice that if not avoided can result in minor bodily injury or property damage.

I . IMPORTANT MESSAGE

- ▶ To reduce the risk of electrical shock, DO NOT remove the cabinet. Refer service to qualified service personnel.
- ▶ Before operating the device, read and understand this manual.

II . BEFORE INSTALLATION

- ▶ The concentrator should always be kept upright to prevent cabinet damage while being transported.
- ▶ If the electrical source power voltage is unstable that beyond normal power rang, please add the voltage stabilizer.
- ▶ Please use eligible, safe power set and junction box.
- ▶ Non-professional people DO NOT open oxygen concentrator's cabinet.

SAFETY NOTES

III. LOCATING

- ▶ You may select a room in your house where using your oxygen concentrator would be most convenient. Your concentrator can easily move from one room to other room by the wheels.
- ▶ Be certain to place the device so all sides are at least 10 cm (4 inches) away from walls, draperies, furniture, or other obstruction. DO NOT place the unit in a confined area.
- ▶ Oxygen concentrator must avoid heat source, fire source, wetness, exorbitant or over-low extra ventricular condition.
- ▶ Sundries and vessel do not be placed on top of the concentrator.

SAFETY NOTES

NEVER block the air openings of the unit or place it on a soft surface, such as a bed or couch, where the air opening may be blocked. Keep the openings free from lint, hair and the like.

IV. USING

- ▶ The use of oxygen therapy requires that special care be taken to reduce the risk of fire. Users MUST NOT SMOKE while using this device. Keep all matches, lighted cigarettes or other sources of ignition out of the room in which this product is located. NO SMOKING signs should be prominently displayed. Textiles and other materials that normally would not burn are easily ignited and burn with great intensity in oxygen enriched air. Failure to observe this warning can result in severe fire, property damage and cause physical injury or death.
- ▶ For optimum performance, do not open or turn off the concentrator frequently, reset after 3 ~ 5 minutes. Shorter periods of operation may reduce maximum product life.
- ▶ A spontaneous and violent ignition may occur if oil, grease or greasy

SAFETY NOTES

substances come in contact with oxygen under pressure. These substances MUST be kept away from the oxygen concentrator, tubing and connections, and all other oxygen device.

DO NOT use any lubricants unless recommended by manufacturer.

V. MAINTENANCE

- ▶ The oxygen concentrator was specifically designed to minimize routine preventive maintenance at intervals of once per year. Only professionals of the healthcare field or persons fully conversant with this process such as authorized or factory trained personnel should perform preventive maintenance or performance adjustments on the oxygen concentrator.

VI. RADIO FREQUENCY INTERFERENCE

This equipment generates, uses and can radiate radio frequency energy and, if not installed according with the instructions, may cause harmful interference to other devices in the vicinity. However, there is no guarantee that interference will not occur in a particular installation. If this equipment does cause harmful interference to other devices, which can be determined by turning the equipment off and on, the user is encouraged to try to correct the interference by one or more of the following measures:

- Reorient or relocate the receiving device.
- Increase the separation distance between the equipment.
- Connect the equipment into an outlet on a circuit different from that which the other device(s) are connected.
- Consult the manufacturer or service technician for help.

VII. TO REDUCE THE RISK OF BURNS, ELECTROCUTION, FIRE OR INJURY TO PERSONS

SAFETY NOTES

- ▶ Avoid using while bathing. If continuous usage is required by the physician's prescription:
The concentrator must be located in another room at least 2.5m from the bath.
- ▶ DO NOT come in contact with the concentrator while wet.
- ▶ DO NOT place or store product where it can drop into water or other liquid.
- ▶ DO NOT reach for product that has fallen into water. UNPLUG IMMEDIATELY.
- ▶ A product should NEVER be left unattended when plugged in.
- ▶ This device is to be used only in accordance with the prescription of a physician and this User's Manual. If at any time the patient or attendant concludes that the patient is receiving an insufficient amount of oxygen, the supplier and/or physician should be contacted immediately. No adjustments should be made to the flowrate unless prescribed by a physician.
- ▶ Close supervision is necessary when this product is used near children or physically-challenged individuals.
- ▶ Use this product for only intended use as described in this manual.
- ▶ DO NOT use parts, accessories or adapters other than those authorized by manufacturer.
- ▶ DO NOT connect the concentrator in parallel or series with other oxygen concentrators or oxygen therapy devices.
- ▶ Use of some administration accessories or certain humidifiers not specified for use with oxygen concentrator may impair the performance.
- ▶ In certain circumstances oxygen therapy can be hazardous. Manufacturer recommends that you seek medical advice before using this product.
- ▶ Avoid creation of any spark near medical oxygen equipment. This includes sparks from static electricity created by any type of friction.
- ▶ The shelf life of the device is 5 years after starting operating.

FEATURES

I . SUMMARY

- ▶ The oxygen concentrator is intended for individual use in the home. It is an electronically operated device that separates oxygen from room air. It provides high concentration of oxygen directly to you through a nasal cannula. Clinical studies have documented that oxygen concentrators are therapeutically equivalent to other types of oxygen delivery systems.
- ▶ This user's manual will tell you about your concentrator and will serve as a reference as you use your concentrator.

II .CHARACTERS

- ▶ Complete plastic out shell, safe and reliable.
Timing accumulates function, show total operating hours through the display screen.
- ▶ Timing turns off function using convenience.
- ▶ Compressor pressure relief valve help the device safer.
- ▶ Power interruption alarm function.
- ▶ Device failure alarm function (including pressure/cycle failure, compressor failure, low oxygen concentration).
- ▶ Compressor with over heat protect function to gain in safety of the compressor and the concentrator.
- ▶ Remote control function.

III .SPECIFICATIONS

1. Maximum Recommend Flow Rate: 5L/min
2. Flow Range: 0.5~5L/min
3. Change in maximum recommended flow when back pressure of 7kPa is applied: 0.5L/min

FEATURES

4. Oxygen Concentration: 95.5% ~ 87%

5. Output Pressure: 40 ~ 70kPa

6. Oxygen Concentration: %

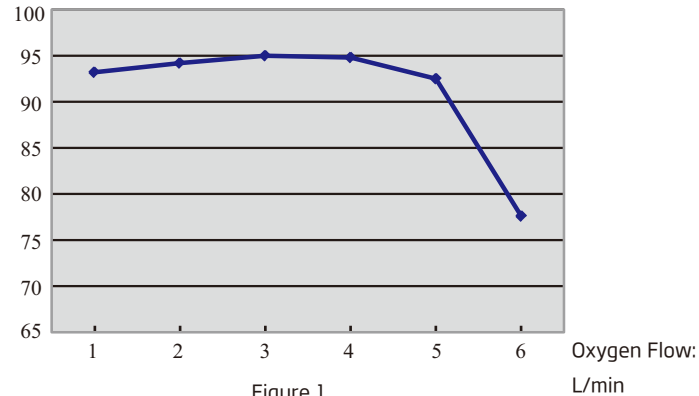

7. Pressure Relief Mechanism Operational at: 250kPa ± 25kPa

(36.25psi ± 3.63psi)

8. Sound Level:

Average (Front Side): 48dB(A), Average(Whole Unit): 52dB(A).

9. Power Supply:

AC100V ± 10% AC120V ± 10% AC220V ± 10% AC230V ± 10%

50Hz ± 2% 60Hz ± 2%

10. Input Power: 400VA

11. Net Weight: 15.5kg

12. Dimension: W39cm(15.4 ") × D24.5cm(9.7 ") × H50cm(19.7 ")

13. Altitude: Up to 1828 meters (6000 ft) above sea level without degradation of concentration levels. From 1828 meters (6000 ft) to 4000 meters (13129 ft) below 90% efficiency.

FEATURES

14. Safety System:

- Over Current or Connection Loosen: Unit Shut Down
- Compressor Over Hot: Unit Shut Down
- Pressure, Cycle Failure: Alarming and Shut Down
- Compressor Failure: Alarming and Shut Down
- Low Oxygen Concentration

15. Minimum Operating Time: 30minutes

16. Electric classification: class II equipment, type BF applied part

17. Work system: work continuously.

18. Normal Operating Condition:

- Temperature range: 10°C ~ 40°C (50°F ~ 104°F)
- Relative humidity: 30% ~ 75%
- Atmosphere pressure: 860hPa ~ 1060hPa (12.47psi ~ 15.37psi)

⚠ CAUTION: When storage/transportation condition is lower than 5°C, please put the device in normal operating condition more than 4 hours before operating.

19. Oxygen Output Temperature: ≤ 46°C

20. Cannula length DO NOT more than 15.2m (50ft) and no twist.

21. Storage and Transportation Condition:

- Temperature range: -20°C ~ +60°C (-4°F ~ +140°F)
- Relative humidity: 10% ~ 93% Non-condensing.
- Atmosphere pressure: 700hPa ~ 1060hPa (10.15psi ~ 15.37psi)

⚠ CAUTION: The device should be stored with no strong sunlight, no corrosive gas and well ventilated indoor area. The device must be transported and used in the vertical position only.

HANDLING

I . UNPACKING

⚠ CAUTION: Unless use the oxygen concentrator, retain containers and packing materials for storage until use of the concentrator is required.

1. Check for any obvious damage to the carton or its contents. If damage is evident, please notify the carrier or local dealer.
2. Remove all loose packing from the carton.
3. Carefully remove all the components from the carton.

II .INSPECTION

1. Examine exterior of the oxygen concentrator for nicks, dents, scratches or other damages.
2. Inspect all components.

III .STORAGE

1. Store the repackaged oxygen concentrator in a dry area.
2. DO NOT place other objects on top of the repackaged concentrator.

OPERATING & INSTALLATION

I . FEATURE VIEW

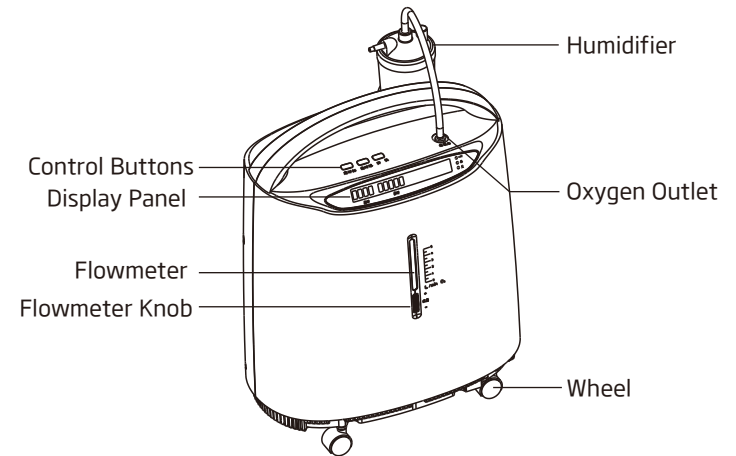

Figure 2: Fullview (Front)

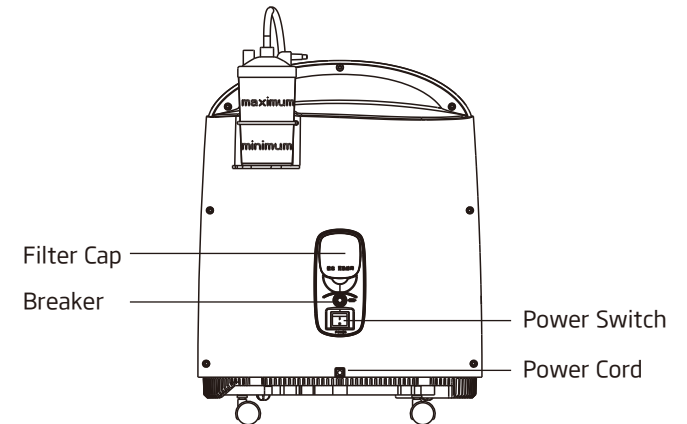

Figure 3: Fullview (Back)

OPERATING & INSTALLATION

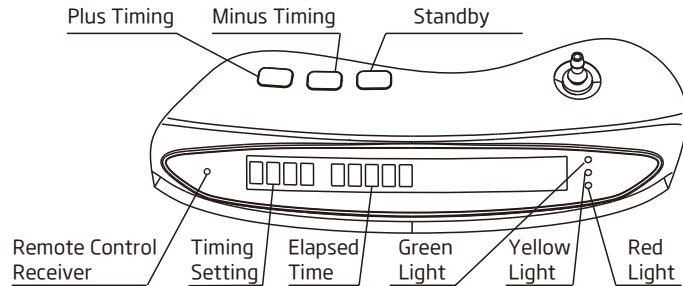

Figure 4: Control Panel

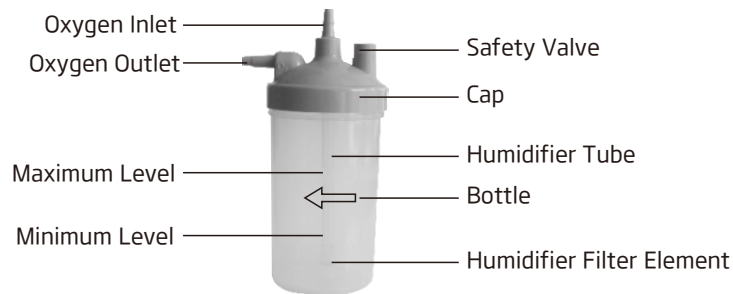

Figure 5: Humidifier Components

II .PREPARE WORK

1. Unscrew the bottle from the humidifier clockwise. Fill the bottle with pure water (or distilled water) to the level between MAXIMUM and MINIMUM. DO NOT fill humidifier bottle over MAXIMUM level. (Figure 5)
2. Screw securely the bottle back counterclockwise. (Recommend to use Yuwell Humidifier p/n: 20006388)
3. Connect the power supply.

OPERATING & INSTALLATION

- ⚠ CAUTION:**
- 1) If the concentrator has a damaged cord or plug, if it is not working properly, if it has been dropped or damaged, or dropped into liquid, call Qualified Service Personnel for examination and repair.
 - 2) Keep the cord away from HEATED or HOT surfaces.
 - 3) Do not move or relocate concentrator by pulling on the cord.
 - 4) Do not use extension cords with this unit.

NOTE: Concentrator may be used during the initial start warm-up time (approximately 30 min) while waiting for the O₂ purity to reach maximum.

III. OXYGEN ABSORBING OPERATION

1. FLOWRATE (Figure 6)

- ▶ Turn the flowrate knob to the setting prescribed by your physician or therapist.

NOTE: To properly read the flowrate, locate the prescribed flowrate line on the flowmeter.

Next, turn the flow knob until the ball rises to the line.

Now, center the ball on the L/min line prescribed.

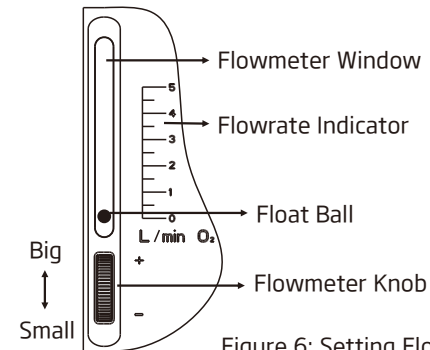

Figure 6: Setting Flowrate

OPERATING & INSTALLATION

⚠ CAUTION: If the flowrate on the flowmeter ever falls below 0.5L/min, check tubing or accessories for blocked or kinked tubing or a defective humidifier bottle.

- ▶ Meanwhile, humidifier bottle will have air bubble around the sieve core. Then, oxygen comes from the oxygen outlet.

2. Connect oxygen cannula to oxygen outlet, the other end match the patient.

Note: The time of absorbing oxygen and the flowrate range according to the doctor's advices.

IV. ALARM SIGNAL

Concentrator has following failure alarm function:

- 1) Pressure and cycle failure
- 2) Compressor failure
- 3) Low oxygen concentration

Note: All the alarms of the device are low priority.

- ▶ Initial startup of the concentrator
When the unit is turned on, the green light will come on After 5 minutes, the oxygen sensor will be operating normally and will control the indicator lights depending on oxygen concentration values. The explanations of the indicator light functions are as follows.
- ▶ Explanation of the indicator light

Symbol	Status	Indicator lights
I/O	SYSTEM OKAY (O ₂ concentration is greater than 82%.)	Green
	O ₂ concentration is greater than 50% and less than 82%.	Green, Yellow

OPERATING & INSTALLATION

Symbol	Status	Indicator lights
	SYSTEM FAILURE (O ₂ concentration is less than 50%; Or, High/Low cycle pressure failure alarm; Or, Compressor circuit failure alarm)	Red

- ▶ Alarm signal register

1. O₂ concentration is greater than 82%. Green light illuminates, and panel shows " - - - H elapsed time H" . Normal Operation.
2. O₂ concentration is greater than 50% and less than 82%. Green and yellow light illuminate, and panel shows " - - - H elapsed time H" . Call Supplier Immediately. You may continue to use the concentrator unless instructed otherwise by your supplier. Be certain that BACKUP OXYGEN is nearby.

NOTE: Concentrator will reach to most stable state after warm-up (approximately 30 minutes).

3. O₂ concentration is less than 50%. Red light illuminates, continuous audible alarm sounds, panel shows word "LO" and the unit shutdown. Switch immediately to backup oxygen supply. Call supplier immediately.
4. Low/High pressure, cycle failure alarm Red light illuminates, continuous audible alarm sounds, and panel shows word "E1" or "E2" . Total unit shutdown. Switch immediately to backup oxygen supply. Call supplier immediately.
5. Compressor failure alarm Red light illuminates, continuous audible alarm sounds, and panel shows word "E3" or "E4" . Total unit shutdown. Switch immediately to backup oxygen supply. Call supplier immediately.

OPERATING & INSTALLATION

V.SETTING TIMING UP

- ▶ User can press the timing button to setting the operating time in 0~2 Hours. When it start working, the display shows “ - - - H elapsed time H ” , it means that timing function is closed. It will work continually until power supply cuts off.
- ▶ Press the “+” button once, operation time increases 1 minute, holding the button more than 1.5 seconds it will increase continually.
- ▶ Press the “-” button once, operation time decrease 1 minute, holding the button more than 1.5 seconds it will decrease continually.
- ▶ The device will auto turn off and the display will show “00:00H” when finishing timing. Reset timing function.

VI.TURNNING OFF

- ▶ During using the device, user can press down the standby button, mounted in control panel, to stop/start oxygen supply.
- ▶ Take off oxygen cannula from oxygen outlet first, turn off power switch, and then cut off the power source.

VII.SYMBOLS

Symbol	Description	Symbol	Description
~	Alternating current	⚠	Consult the manual
□	Class II Equipment	♻	Type BF Applied par
○	OFF (power disconnection from the mains)		ON (power connection to the mains)

OPERATING & INSTALLATION

Symbol	Description	Symbol	Description
⏸	Stacking Limitation	↑↑	Keep Up
🚫	No Smoking	🍷	Fragile
☔	Keep Dry		

VIII.Remote Control

- ▶ Use infrared remote controller to operate the device. (Figure 7)

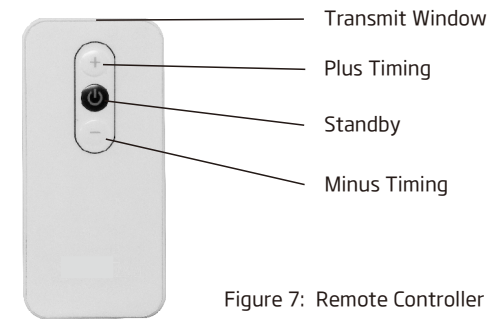

Figure 7: Remote Controller

Note: During remote control operating, the remote controller must be toward the receiver which is located in the control panel.

MAINTENANCE

NOTE: Power should be disconnected before beginning preventive maintenance on the concentrator. The concentrator is specifically designed to minimize routine preventive maintenance at intervals of once per year. In places with high dust or soot levels, maintenance may need to be performed more often. The following must be performed at a minimum of one year in service to assure years of additional reliability.

I .CLEAN CABINET

⚠ WARNING: CUT OFF the power supply first to avoid electrical shock.
DO NOT remove device cabinet.

Clean the cabinet with a mild household cleaner and non-abrasive cloth or sponge at least one time a month. Do Not drop any liquid into the seam of the device.

II .CLEAN OR REPLACE FILTER

Please clean or replace the filters in time, it's very important to protect compressor and to extend the device life.

▶ Disassembly Filter

Remove the filter cover and take out the filter.

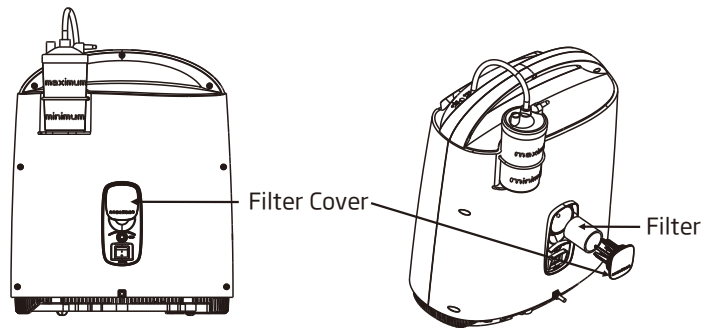

Figure 8: Remove Filter

MAINTENANCE

▶ Clean Filter

- 1) Clean the filter with a soft cleaner or wash in warm soapy water and rinse thoroughly.
- 2) DRY the filter thoroughly before reinstallation.
- 3) The filter must clean or replace.

⚠ CAUTION: DO NOT operate the concentrator without installing filter, or while filter is wet. These actions could permanently damage the concentrator.

▶ Clean Humidifier

- 1) Remove the humidifier bottle from the humidifier cap then clean the bottle.
- 2) Remove the humidifier tube and diffuser then clean them.

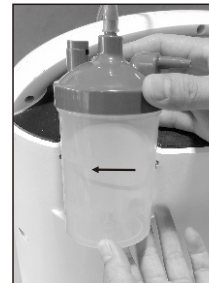

Figure9



Figure 10

TROUBLESHOOTING

TROUBLESHOOTING GUIDE

Symptom	Probable cause	Solution
Power Interruption Alarm: Press the power on switch on the control panel, buzzer alarming, display not lit, device not work.	1) Power cord and wall outlet have poor contact.	1) Re-insert the power cord into wall outlet securely.
	2) Wall outlet no power output.	2) Change to another wall outlet.
	3) Low power of wall outlet.	3) Change to another wall outlet. Do not use any extension cord.
	4) Breaker reset button raised.	4) Press down the breaker reset button.
	5) If the device is still not working, please contact the supplier.	
Concentrator is working, the operating sound is normal, the flowmeter knob can be adjusted but no oxygen output or weak output.	1) Leakage between humidifier bottle and cap.	1) Re-insert the power cord into wall outlet securely.
	2) The safety valve of humidifier is opened.	2) Change to another wall outlet.
	The connection between oxygen output and humidifier is leaking.	3) Re-install the humidifier tubing.
	4) The accessory (nasal cannula, mask, humidifier, tubing..., etc.) is leaking.	4) Replace the leaked accessory.
	5) If the phenomenon is still appeared, please contact the supplier.	

TROUBLESHOOTING

Symptom	Probable cause	Solution
Concentrator is working, but green light, yellow light illuminate at the same time.	1) $50\% \leq \text{Oxygen Concentration} < 82\%$.	1) Clean or replace the filter.
	2) Oxygen flow rate over the maximum recommend flow rate: 5L/min	2) Adjust the flow rate only under the advice of a physician.
	3) If the phenomenon is still appeared, the device can be used but please contact the supplier.	
Concentrator is not working, the red light illuminate, buzzer alarm, the display show "LO"	1) Oxygen Concentration $< 50\%$	1) Clean or replace the filter.
	2) Oxygen flow rate over the maximum recommend flow rate: 5L/min	2) Turn off and re-turn on the device. Adjust the flow rate only under the advice of a physician.
	3) If the phenomenon is still appeared, the device can be used but please contact the supplier.	
Concentrator is not working, the red light illuminate, buzzer alarm, the display show "E1"	1) System cycle pressure is too low.	1) Clean or replace the filter.
) If the phenomenon is still appeared, stop using the device, please contact the supplier immediately.	
Concentrator is not working, the red light illuminate, buzzer alarm, the display show "E2"	1) System cycle pressure is too high.	1) Stop using the device, please contact the supplier immediately.
Concentrator is not working, the red light illuminate, buzzer alarm, the display show "E3"	1) Compressor circuit is opened.	1) Stop using the device, please contact the supplier immediately.
Concentrator is not working, the red light illuminate, buzzer alarm, the display show "E4"	1) Compressor circuit is closed.	1) Stop using the device, please contact the supplier immediately.

TROUBLESHOOTING

Symptom	Probable cause	Solution
The nasal cannula is fogged with vapor or full of liquid drops. (Remove the vapor or liquid drops method: Turn on the device and connect the tubing to the oxygen outlet. Use your finger to block and release the end of the tubing several times to remove the moisture and liquid.)	1) Poor ventilation around the around the device, so operating temperature is too high.	1) Make sure the device is at least 10 cm away from the walls, other jam or heater.
	2) The water which added to humidifier is too hot.	2) Add cold water to humidifier.
	3) Add too many water into humidifier.	3) Water added should between the maximum and minimum levels in humidifier.
	4) The device stops suddenly during operating.	4) Turn off the device immediately. Restart the device to remove the moisture and liquid.
	5) Accessory is connected to the device. The tubing is kinked and the device stops suddenly.	5) Smooth the nasal cannula and tubing.
	6) Cooling fan which mounted inside the device stop running or rotate slowly, make the operating temperature is too hot.	6) Replace the cooling fan. Note: Cut off the power first. And perform by qualified personnel only.
	7) If the phenomenon is still appeared, the device can be used but please contact the supplier.	
Remote control malfunction.	1) Do not use the remote controller in the receiving area.	1) Operate the remote controller in the front side of the device.
	2) Low battery.	2) Replace the battery in the remote controller.

⚠ CAUTION: If you have all other problems, TURN OFF the concentrator first, use your reserve oxygen supply, and contact the supplier immediately.

OTHER ATTENTION ITEMS

I . GAS PASS OPERATION SKETCH MAP

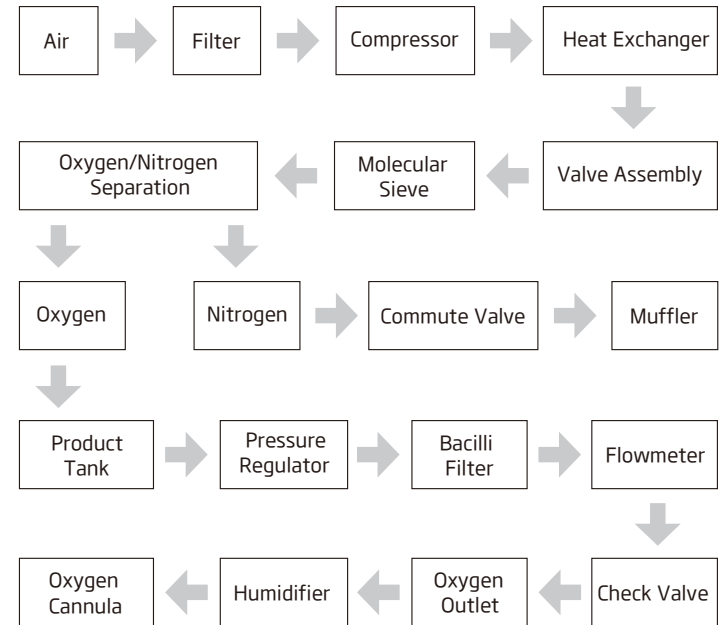

OTHER ATTENTION ITEMS

II . ELECTRICAL RATIONALE

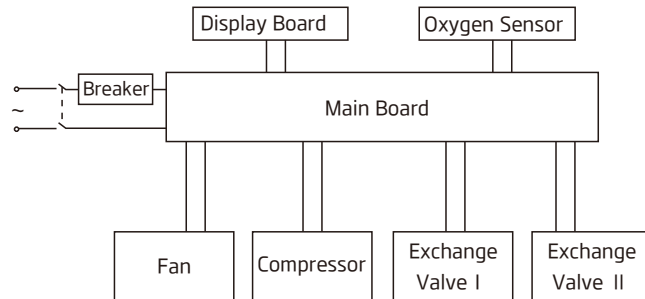

III.PACKING LIST

1. Oxygen Concentrator: 1 unit
2. User Manual: 1 piece
3. Filter: 1 piece

IV.DEVICE DISPOSAL

Contact the local city or town offices for proper disposal instructions for oxygen concentrator.