

文件类型	技术文件	文件编号	S-65.02.0505B	
机密等级	秘密	版本	AB	
项目代码	DM1104B	页码	共 259 页	
项目名称： 五分类血液细胞分析仪				
文件名称： 1104B 使用说明书（英文）				
适用范围： DM1104B				
拟制： 日期：2023-04-06	钟晓丹	审核： 日期：2023-04-06	张淑娟	批准： 日期：2023-04-06
张淑娟				
相关文档				
文件编号	文件名称			版本
磁盘文件名称	字节数	复核	日期	

修订记录

版本	TCN/ECR/ PCN 编号	修订内容概述	修订人	修订日期
2.0	/	新建。	张淑娴	2015-12-30
3.0	/	<ul style="list-style-type: none"> ● 大气压范围上限改为 106kpa。 ● “1.5 Symbol Conventions”: 更新请勿丢弃 (垃圾筒) 标志。 ● 新增“2.6.5 Connecting the LIS”。 ● “6.5.3 Prediluted Samples”: 增加“采一次血所配置的预稀释样本可做两次计数。”。 ● “7.4 Running Samples”: 增加分析模式的描述。 ● “7.5.1 Automatic Saving of Analysis Results”、“8.1 Intruction”: 删除样本结果数存储上限数。 ● 新增“7.6.6 Patient Information”。 ● “5.9 Auxiliary Settings”: 新增“Automatically generate the delivery date”和“Automatically generate the sampling date”。 ● 更新“A.7 EMC Description”。 ● 更新“A.9 Dimensions and Weight”。 ● 更新“A.10 Expected Service life” ● “4.4.2 Derivation of WBC-Related Parameters”中更新白细胞计算的描述。 ● “3.3 检测参数”: 补充 WBC 直方 Figure ● 更新预稀释比: 20ul 血+480ul 稀释液, 形成 1:25 的预稀释样本。(“4 Working Principle”、“6.5.3 Prediluted Samples”) ● “Preface”: 更新注册地址; 补充欧代公司名称 Renault-Petersen Limited; 增加 Dymind 商标声明。 	张淑娴	2016-04-15
4.0	ECR2016004	<ul style="list-style-type: none"> ● “5.8 Print Settings”: 增加打印机分辨率、模板删除和导出功能。 ● “6.5 Sample Collection and Handling”、“7.4 Running Samples”: 增加离心管应向上放置的说明。 ● “8.4.8 Query”: 增加“参数选择”查询条件。 ● “9.2.2.1 Entering QC Information”: 增加“在用”参数。 ● 更新“12.4.2 Voltage and Current”截图。 ● 更新“11.2.2 Closed system”: 稀释液和溶血剂都只支持卡封闭。 ● 增加“12.4.3 Disk Info”、“12.7 Data Cleanup”、“12.9 Exporting Host Information”。 ● “Appendix C Packing List”: 删除条码扫描仪。 ● “4.3 Dilution”: 更新液路 Figure。 ● “L-J Quality”: 质控模式更改为“Whole Blood-DIFF”、“Predilute-DIFF”。 	张淑娴	2016-06-06
4.1	ECR2016007	<ul style="list-style-type: none"> ● “4.4.1 Working Principle of Laser-based Flow Cytometry”: 修正中角和散点 Figure 的描述, 更新散点 Figure 为二维散点 Figure ● “A.9 Expected Service Life”改为: 5 years (based on a daily test volume of 100 samples). ● “A.5 Input/ouput Device”: 增加熔断器的规格描述。 	张淑娴	2016-09-08

版本	TCN/ECR/ PCN 编号	修订内容概述	修订人	修订日期
5.0	ECR2016011	<ul style="list-style-type: none"> 更新“10.3.3 Auto Calibration Using Calibrators”和“10.3.4 Auto Calibration Using Fresh Blood Samples”: 增加清空相关描述。 “1.5 Symbol Conventions”: 更新激光警告和相关说明。 “8.4.8 Query” (回顾): 更新“参数”选项。 更新系统默认休眠时间为 30 分钟。 更新“12.7 Version Information”。 更新欧代公司和地址。 	张淑娴	2016-11-17
6.0	ECR2016010	<ul style="list-style-type: none"> 增加“A.10 Sample Interference”。 更新“11.2.2 Closed system”关于封闭试剂的设置描述。 	张淑娴	2016-12-02
7.0	ECR2016012	<ul style="list-style-type: none"> 增加 DF51,DF53 型号 更新“5.6.2 LIS Communication”: 增加“Figure 片格式”、“修改结果后自动通信”, 删除协议类型和版本。 更新“12.9 Downloading Service Logs”。 更换主机正面 Figure (错用了 1001 的 Figure) 	张淑娴	2017-01-09
8.0	ECR2017001	<ul style="list-style-type: none"> “1.5 Symbol Conventions”: 更新激光警告和搬运标贴。 “5.6.2 LIS Communication”: 更新描述; 增加匹配方式。 “5.9 Auxiliary: 增加快捷保存相关选项。 “6.5.3 Predilute Samples”增加描述: 预稀释模式分析过程中, 请勿添加抗凝剂, 否则会影响样本分析结果。 “Error Message Reference”: 更新无试剂的描述。 “A.9 Expected Service Life”: 改为 8 年。 	张淑娴	2017-02-23
9.0	ECR2017003	<ul style="list-style-type: none"> 增加 F52、DF55、DF56 机型 (左侧面上方增加热敏打印机, 并增加 P-LCC 和 P-LCR) <ul style="list-style-type: none"> ➢ P-LCC/P-LCR 相关内容: “3.3 Measurement Parameters”、“4.6.3 PLT”、“A.3 Parameters” ➢ 热敏打印机的相关内容: “A.6 Input/output Device”、“3.4.1 Main unit”、“3.4.5 Paper Feed Key”、“3.4.6 Thermal Printer”、“5.10 Thermal Printer Settings”、“A.6 Input/output Device”。 更新“Bed No.”的描述。 “13.3 Error Message Reference”: 更新稀释液接近用完的描述。 	张淑娴	2017-03-16
10.0	ERC2017006	<ul style="list-style-type: none"> “Appendix C Packing List”:删除移交验收证明 (英文机型不需要)。 更新“12.2.1 Reagent Replacement”操作界面图片 更新“2.3 Installation Requirements”: temperature 和“A.8 Environment Conditions”: operating environment 为 15°C-30°C。 	张淑娴/宋佳欣	2017-05-19
11.0	ECN2018044	<p>ECN2018044:</p> <ul style="list-style-type: none"> 注册地址、售后地址更新。更新欧代地址。 “1.5 Symbols Conventions”更新温度、湿度、大气压符号。修改“温度极限”、“湿度极限”、“大气压力极限”“体外诊断医疗器械”、“使用期限”、“序列编号”、“参阅使用说明书”、“批次代码, 批号”、“避免日晒”的英文名称。 “6.5.3 Prediluted Samples”纠正加稀释液的体积为 	覃洁美	2018-10-10

版本	TCN/ECR/ PCN 编号	修订内容概述	修订人	修订日期
		<p>480μL。</p> <ul style="list-style-type: none"> ● “A.9 Dimensions and Weight”净重由 26.5Kg 改为 28Kg。 ● “2.7 Installing Thermal Paper”更新热敏打印机图。 ● 删除“D&M and Dymind”商标。 ● 更新主机背面图，电气连接图，试剂连接图。 <p>ECR2018006:</p> <ul style="list-style-type: none"> ● 更新邮箱、网址；删除页脚版权所属。 ● “Preface”：增加“Date of manufacture: see product label.”。 ● “1.5 Symbols Conventions”新增“USB interface”。 ● “2.6.5.3 Connecting Analyzer with LIS”更新：“Bidirectional LIS/HIS Communication Timeout”。 ● “5.3.4 Auto Maintenance”新增等待时间。 ● “5.4.3 Ref. Range”更新参考范围。 ● “5.6 Communication Setting”更新：新增“Bidirectional LIS/HIS Communication Timeout”、传输模式改为“Transmission Settings”。 ● “5.8 Print Setting”新增质控图设置。 ● “5.9 Auxiliary Settings”更新描述。 ● 新增“5.10 Patient Information”。 ● 更新“6.3 Startup”：添加登录密码可见选项注意项。 ● “7 Sample Analysis”进入患者信息新增快捷键方式 F4、样本编号描述更新。 ● 新增“8.4.14 CV”。 ● 更新“9.2.3 Quality Control Analysis”，删除“恢复”、新增“上一记录”“下一记录”“打印”。 ● “9.2.4.1 Graph”更新：灰色改为绿色、打印更新。 ● 更新“9.2.4.2 Table”，删除“恢复”、“编辑”改为“编辑结果”。 ● “12.2 Maintenance”更新显示屏检测相关界面。 ● “12.2.6 Auto Prompt for Cleanser Soak”更新描述。 ● “12.3.4 Others”更新 RF 卡自检相关描述。 ● “12.4.3 Disk Information”更新磁盘容量信息。 ● “12.6 Data Cleanup”新增 Core 文件。 ● 新增“12.9 Screen Test”。 ● “A4.4 重复性指标”PLT 更正。 ● “Appendix C Packing List”删除随机试剂。 		

版本	TCN/ECR/ PCN 编号	修订内容概述	修订人	修订日期
12.0	PECR2020003	<ul style="list-style-type: none"> 前言声明增加“Operator's manual is will help you operate the analyzer properly, but not explains for software and hardware configuration. Please refer to the contract of analyzer (if any), packing list or consult Dymind or local agents for detailed configurations.”。 替换“2.6.5.3 Connecting Analyzer with LIS”的 LIS 通信设置界面截图。 在“3.3 Measurement Parameters”、“5.4.5 Research Use Only (RUO) Parameters”和“A.3 Parameters”补充研究参数 NRBC#和 NRBC%的内容。 在“5.6.2 LIS Communication”中增加“启动心跳检测”的内容。 替换“6.5.3 Prediluted Samples”的菜单页截图。（生产 BUG#286） 新增“8.4.15 Research Results”。 在“9.2.2.1 Entering QC Information”中，新增“以二维码方式导入质控信息”和“以文件形式导入质控信息”的内容。 新增“9.2.2.2 Viewing QC File Details”。 删除“Appendix C Packing List”中的列表，并增加“For details, see the packing list file shipped with the device.”。 更正低级错误。 	刘雁贤	2020-02-14
AA	PECR2020067	<ul style="list-style-type: none"> 切换版本为 AA。 增加条形码。 更换注册地址和欧代信息。 加工要求改为最新版本。 	王怡岚	2020-10-17
AA	PECR2021030	<ul style="list-style-type: none"> 文件名称由《S-65.02.0022A[AA] 1104 使用说明书（英文）》改为《S-65.02.0505A[AA] 1104B 使用说明书（英文）》。 项目代码和适用范围由“DM1104”改为“DM1104B”。 更正“12.2.1 Reagent Replacement”的引用链接。 “12.3.1 Syringe and Sampling Mechanism”、“12.3.3 Valve & Pump”中的截图替换为最新。 “12.3.1 Syringe and Sampling Mechanism”的“Sample Syringe”改为“Sampling Syringe”。 “13.3 Error Message Reference”中更新采样注射器相关的故障名称；新增溶血剂注射器相关的故障信息。 “A.7 EMC Description”中的“CISPR 11 Class A”更正为“CISPR 11 Class B”。 	刘雁贤	2021-03-09
AA	PECR2021070	<ul style="list-style-type: none"> 物料编码由 65.02.0505A 升为 65.02.0505B。 切换新 VI。 修改公司 Logo。 加工要求改为最新版本。 欧代信息由“Llins Service & Consulting GmbH Obere Seegasse 34/2, 69124, Heidelberg, Germany”更改为“Eunitor GmbH Kennedydamm 5, 40476 Duesseldorf, Germany”。 	朱红珍	2021-09-30

版本	TCN/ECR/ PCN 编号	修订内容概述	修订人	修订日期
		<ul style="list-style-type: none"> “Preface” 页面增加 Release Date 信息和 IVD 标识，更新欧代标识符号。 更新“1.5 Symbol Conventions” 章节。 PYFWB202109028: <ul style="list-style-type: none"> 在“2.3 Installation Requirements”中，“Relative humidity”修改为“20%~90%”。 在“A.8 Environment Conditions”中，“Operating Environment”的“Relative humidity”修改为“20%~90%”。 		
AB	PECR202215 3	<ul style="list-style-type: none"> 修改低级错误。 更新“13.3 Error Message Reference”中故障信息表。 删除 400 联系电话并修改邮箱为: intl@dymind.com。 修改“Click OK to to close the message box.”为“Click OK to close the message box.”。 更正“4.6.3 PLT”的 P-LCR 和 P-LCC 公式问题。 删除“1.5 符号”章节的禁止堆码标识；新增堆码层数极限标识。 更新“6.5.3 Prediluted Samples”中的菜单页截图。 更新“5.3.4 Auto Maintenance”章节的自动维护截图以及自动清洁液浸泡的内容。 更新“5.8 Print Settings”章节的打印设置截图，并增加打印盒子相关内容。 更新“8.4.15 Research Results”章节的研究结果截图。 更新“5.3.4 Auto Maintenance”章节的自动维护截图以及自动清洁液浸泡的内容。更新“12.2.6 清洁液浸泡自动提醒”的内容。 更新“12.2.6 Auto Prompt for Cleanser Soak”章节内容。 更新“12.3.3 Valve&Pump”章节的阀/泵自检截图及全部阀自检相关内容。 更新“12.5.1 All Logs”章节的全部日志截图，新增试剂日志下拉列表描述。 更新“7.4 Running Samples”章节的模式设置截图及内容。 删除“13.3 Error Message Reference”章节的“样本针堵”故障和相应故障帮助信息。 	董芊	2022-11-04
		<ul style="list-style-type: none"> 更新“4.6.1 Electrical Impedance Method”章节的原理图。 删除“6.7 Shutdown”章节警告标贴旁的“warning”。 	钟晓丹	2023-03-15

加工要求（选择一项）**加工类型：**外购（供应商加工） 自制**封面颜色、图案：**帝迈通用 OEM 定制 无图案 无封面**装订形式（材料）：**胶装过厚塑（限简易操作指南）骑马订（需要封面且内容少于 30 页）订书钉（内容少于 30 页且多于 1 页）其他：**页面形式：**A4A5其他（如***mm×***mm）：**加工的起始页码和纸张要求：**

封面：第 9 页 封底：第 259 页（尾页）

纸张要求：230g 荷兰白卡，彩色

正文：第 11 页~第 258 页

纸张要求：70g 蓝光书纸，黑白，双面打印

技术要求：

封面和封底红色线条 CMYK 值为 20.100.100.0，灰色色块 CMYK 值为 0.0.0.10

封面 Logo 红色部分 CMYK 值为 20.100.100.0，Logo 灰色部分 CMYK 值为 0.0.0.85



Auto Hematology Analyzer

Operator's Manual



Preface

Thank you for purchasing the Auto Hematology Analyzer manufactured by Dymind Biotech. Read and understand the entire operator's manual before operating this device. Store this operator's manual properly for future reference.

Product name: Auto Hematology Analyzer

Model: DF50, DF51, DF53, DF52, DF55, DF56

Product Components: Blood Aspiration Module, Dilution Unit, Cleaning Unit, Analyzing and Measuring Unit and Microprocessor.

Scope of Use: blood cell counting, white blood cell 5-part classification and hemoglobin concentration measurement in clinical examinations.

Date of manufacture: see product label

Release Date: 2023-03-15

Contact Info for After-Sales Services



Shenzhen Dymind Biotechnology Co., Ltd.

10th Floor, Building B, High-tech Park, Guangqiao Road, Tianliao Community, Yutang Street, Guangming District, Shenzhen 518107, P. R. China



Eunitor GmbH

Kennedydamm 5, 40476 Duesseldorf, Germany

Tel: (86-755)26989825

Fax: (86-755)26746162

Email: intl@dymind.com

Website: <http://www.dymind.com>

Copyright

© Shenzhen Dymind Biotechnology Co., Ltd. All rights reserved. This document contains proprietary information of Shenzhen Dymind Biotechnology Co., Ltd. (hereinafter referred to as Dymind Biotech). No part of this document may be reproduced, copied, modified, disclosed, or transmitted in any form or by any means without prior written consent of Dymind Biotech. This document is intended for users of Dymind Biotech equipment, whom are authorized to use this document as they purchase Dymind Biotech equipment. Unauthorized persons are not allowed to use this document.

All information in this document does not constitute a warranty of any kind, express or implied, including, but not limited to, the implied warranties of merchantability and fitness for a particular purpose. Every effort has been made in the preparation of this document to ensure accuracy of the contents. However, Dymind Biotech assumes no liability or responsibility for any errors or omissions in the contents of this document. Dymind Biotech reserves the right to improve any products to enhance product reliability, functionality, or design.

Declaration

This operator's manual may be modified without notice.

Dymind Biotech reserves the right of final interpretation of this operator's manual.

The pictures in this operator's manual are for reference only. If there is inconsistency between the pictures and the actual product, the actual product shall prevail. Do not use the pictures for other than intended use.

Operator's manual is intended to help you operate the analyzer properly, but will not explain software and hardware configuration. Please refer to the contract of the analyzer (if any), packing list or consult Dymind or local agents for detailed configurations.

Dymind Biotech shall be responsible for the safety, security, and performance of the product only when all of the following conditions are met:

- The assembly, re-commissioning, extension, modification, and repair of the product are performed by the authorized personnel of Dymind Biotech.
- The product is operated based on this operator's manual.
- The electrical appliances in the relevant working room comply with applicable national and local requirements.

Contents

Preface	i
1 Manual Overview	1
1.1 Introduction	1
1.2 Who Should Read This Manual	1
1.3 How to Find Information.....	1
1.4 Conventions Used in This Manual.....	2
1.5 Symbol Conventions	2
1.6 Safety Information.....	5
2 Installation	7
2.1 Introduction	7
2.2 Installation Personnel	7
2.3 Installation Requirements	7
2.4 Damage Inspection.....	8
2.5 Unpacking	9
2.6 Connecting the Analyzer System.....	9
2.6.1 Electrical Connections.....	9
2.6.2 Reagent Connections.....	10
2.6.3 Installing the Diluent Float Sensor and Replacing the Reagents.....	11
2.6.4 Installing the Waste Float Sensor	12
2.6.5 Connecting the LIS.....	12
2.7 Installing Thermal Paper (for DF52, DF55 and DF56 only).....	16
3 System Overview	18
3.1 Introduction	18
3.2 Who Should Read This Manual	18
3.3 Measurement Parameters	18
3.4 Structure of the Analyzer.....	20
3.4.1 Main unit.....	21
3.4.2 Touch screen	22
3.4.3 Aspirate key.....	22
3.4.4 Power/Status indicator	22
3.4.5 Paper Feed Key (for DF52, DF55 and DF56 only)	23
3.4.6 Thermal Printer (for DF52, DF55 and DF56 only).....	23
3.4.7 Power switch	23
3.4.8 USB interface	23
3.4.9 Network interface	23
3.4.10 External Equipment (Optional).....	24
3.5 User Interface	24
3.6 Reagents, Controls and Calibrators.....	25
3.6.1 Reagents	26

3.6.2 Controls and Calibrators	26
4 Working Principle	27
4.1 Introduction	27
4.2 Aspiration	27
4.3 Dilution	27
4.3.1 Dilution Procedure in Whole-blood CBC+DIFF Mode.....	28
4.3.2 Dilution Procedure in Predilute CBC+DIFF Mode.....	29
4.4 WBC Measurement	29
4.4.1 Working Principle of Laser-based Flow Cytometry	29
4.4.2 Derivation of WBC-Related Parameters	31
4.5 HGB Measurement	32
4.5.1 Colorimetric Method	32
4.5.2 HGB.....	32
4.6 RBC/PLT Measurement	32
4.6.1 Electrical Impedance Method.....	32
4.6.2 RBC.....	33
4.6.3 PLT	34
4.7 Flushing	34
5 Setup.....	35
5.1 Introduction	35
5.2 Interface Introduction	35
5.3 System Settings	36
5.3.1 Date and Time	36
5.3.2 Input Settings	38
5.3.3 Lab Information	38
5.3.4 Auto Maintenance	40
5.4 Parameter Settings	41
5.4.1 Data Dictionary.....	41
5.4.2 Parameter Unit.....	44
5.4.3 Ref. Range	47
5.4.4 Microscopic Exam. Settings.....	52
5.4.5 Research Use Only (RUO) Parameters.....	54
5.4.6 Customized Parameters.....	56
5.5 Meterage Settings.....	58
5.5.1 Gain Settings.....	58
5.5.2 Flag	60
5.6 Communication Settings.....	61
5.6.1 Host Network Settings.....	61
5.6.2 LIS Communication	62
5.7 User management	67
5.7.1 Accessing the Interface.....	67
5.7.2 Creating a User	68
5.7.3 Editing a User.....	69
5.7.4 Deleting a User	69
5.7.5 Setting the Default User	69

5.7.6 Changing Password	70
5.7.7 Resetting Password	70
5.8 Print Settings	71
5.9 Auxiliary Settings	77
5.10 Patient Information	79
5.11 Thermal Printer Settings (for DF52, DF55 and DF56 only)	80
6 Daily Operations	82
6.1 Introduction	82
6.2 Pre-operation Preparation	82
6.3 Startup	84
6.4 Daily Quality Control	85
6.5 Sample Collection and Handling	85
6.5.1 Venous Whole Blood Samples	86
6.5.2 Capillary Whole Blood Samples	86
6.5.3 Prediluted Samples	87
6.6 Sample Analysis	89
6.7 Shutdown	89
7 Sample Analysis	91
7.1 Introduction	91
7.2 Interface Introduction	91
7.3 Entering Sample Information	93
7.4 Running Samples	96
7.5 Dealing with the Analysis Results	100
7.5.1 Automatic saving of analysis results	100
7.5.2 Parameter Flags	100
7.5.3 Flags of Abnormal Blood Cell Differential or Morphology	100
7.6 Functions of the Buttons	103
7.6.1 Previous/Next	103
7.6.2 Mode & ID	103
7.6.3 Pre-entry	103
7.6.4 Validate/Cancel Validation	103
7.6.5 Print	103
7.6.6 Patient Information	103
7.6.7 Customized Parameters	107
7.6.8 Microscopic Exam Parameters	108
7.6.9 Communication	109
7.6.10 Edit Result	109
7.6.11 Delete	110
8 Result Review	111
8.1 Introduction	111
8.2 Interface Introduction	111
8.3 Sample List	112
8.4 Functions of the Buttons	112
8.4.1 Validate	112
8.4.2 Cancel Validation	113

8.4.3 Print.....	114
8.4.4 Delete.....	114
8.4.5 Export.....	115
8.4.6 Edit Result.....	118
8.4.7 Patient Info.....	118
8.4.8 Query.....	122
8.4.9 Graph.....	123
8.4.10 Microscopic Exam Parameters.....	124
8.4.11 Customized Parameters.....	125
8.4.12 Communication.....	126
8.4.13 Run Chart.....	129
8.4.14 CV.....	131
8.4.15 Research Results.....	133
9 Quality Control.....	135
9.1 Introduction.....	135
9.2 L-J Quality Control.....	135
9.2.1 QC Principle.....	135
9.2.2 QC Settings.....	136
9.2.3 Quality Control Analysis.....	147
9.2.4 QC Result Review.....	153
9.3 X-B Quality Control.....	165
9.3.1 QC Principle.....	165
9.3.2 QC Settings.....	165
9.3.3 Quality Control Analysis.....	168
9.3.4 QC Result Review.....	168
10 Calibration.....	178
10.1 Introduction.....	178
10.2 When to Calibrate.....	178
10.3 How to Calibrate.....	179
10.3.1 Preparation.....	179
10.3.2 Manual Calibration.....	180
10.3.3 Auto Calibration Using Calibrators.....	182
10.3.4 Auto Calibration Using Fresh Blood Samples.....	184
10.4 Verifying Calibration Coefficients.....	186
11 Reagent Management.....	187
11.1 Accessing the Interface.....	187
11.2 Setting Reagent Information.....	188
11.2.1 Open System.....	188
11.2.2 Closed System.....	190
11.3 Replacing Reagents.....	192
12 Service.....	193
12.1 Introduction.....	193
12.2 Maintenance.....	193
12.2.1 Reagent Replacement.....	194

12.2.2 Cleaning	196
12.2.3 Maintenance.....	197
12.2.4 Comprehensive Device Maintenance	201
12.2.5 Auto Clean.....	207
12.2.6 Auto Prompt for Cleanser Soak	207
12.2.7 Auto Sleep.....	208
12.3 Self-test.....	208
12.3.1 Syringe and Sampling Mechanism	209
12.3.2 Pressure and Vacuum.....	209
12.3.3 Valve & Pump.....	210
12.3.4 Others.....	211
12.4 System Status	212
12.4.1 Temperature	212
12.4.2 Voltage and Current	213
12.4.3 Disk Information	214
12.5 Log	214
12.5.1 All Logs.....	214
12.5.2 Parameter Revision Logs.....	215
12.5.3 Fault Logs	216
12.5.4 Other Logs	217
12.6 Data Cleanup.....	217
12.7 Version Information.....	219
12.8 Touch Screen Calibration.....	221
12.9 Screen Test.....	221
12.10 Downloading Service Logs	222
13 Troubleshooting	224
13.1 Introduction	224
13.2 Dealing with Error Messages.....	224
13.3 Error Message Reference.....	225
Appendix A Specifications	230
A.1 Classification	230
A.2 Reagents	230
A.3 Parameters	230
A.4 Performance Specifications.....	232
A.5 Sample Interference	233
A.6 Input/output Device	235
A.7 EMC Description	235
A.8 Environment Conditions	236
A.9 Dimensions and Weight	237
A.10 Expected Service Life.....	237
A.11 Contraindications.....	237
Appendix B Terms and Abbreviations.....	238
Appendix C Packing List	239

1 Manual Overview

1.1 Introduction

This chapter explains how to use this operator's manual of Auto Hematology Analyzer, which is shipped with the auto hematology analyzer and contains reference information about the analyzer and procedures for operating, troubleshooting and maintaining the analyzer.

Read this manual carefully before operating the analyzer and operate your analyzer in strict accordance with this manual.

1.2 Who Should Read This Manual

This manual contains information written for clinical laboratory professionals to:

- Learn about the hardware and software of the analyzer.
- Customize system settings.
- Perform daily operations.
- Perform system maintenance and troubleshooting.

1.3 How to Find Information

This operator's manual comprises 13 chapters and 3 appendices. Find the information you need by referring to the table below.

See...	You can find...
1 Manual Overview	Instructions for using the auto hematology analyzer.
2 Installation	Installation requirements for the auto hematology analyzer.
3 System Overview	Applications, measurable parameters, instrument configuration, software interface and software operations of the auto hematology analyzer.
4 Working Principle	Measuring principle and procedures of the auto hematology analyzer.
5 Setup	Settings of the system parameters such as the software date format and parameter units.
6 Daily Operations	Daily operations such as sample collection and preparation, the analysis procedures, startup and shutdown of the instrument.
7 Sample Analysis	Sample analysis procedure and handling of the analysis results.

See...	You can find...
8 Result Review	Review of the analysis results.
9 Quality Control	Basic requirements for quality control and the quality control methods provided by the auto hematology analyzer.
10 Calibration	Basic requirements for calibration and the calibration methods provided by the auto hematology analyzer.
11 Reagent Management	Settings and management of the reagents for the auto hematology analyzer.
12 Service	Methods for maintaining and testing the auto hematology analyzer.
13 Troubleshooting	Troubleshooting methods for the auto hematology analyzer.
Appendix A Specifications	Specification indicators of the auto hematology analyzer.
Appendix B Terms and Abbreviations	Terms and abbreviations for the auto hematology analyzer.
Appendix C Packing List	Packing list for the auto hematology analyzer.



1.4 Conventions Used in This Manual



The texts with special meaning in the manual are highlighted by different fonts and formats.

Format	Meanings
[XX]	All uppercase characters enclosed in [] indicate the name of a key on the analyzer or the peripheral keyboard, such as [ENTER].
XX	Bold characters indicate text displayed on the screen, such as Report .
XX	XX indicates variables and the specific content depends on the actual situation.
<i>XX</i>	Bold and italic characters indicate chapter titles, such as <i>1.1 Introduction</i> .

1.5 Symbol Conventions

The following symbols are used to indicate danger and alert messages in this manual.





When you see ...	Then ...
	Follow the instruction below the symbol to avoid potential biocontamination.
 WARNING	Follow the instruction below the symbol to avoid personnel injury.









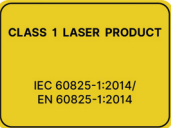

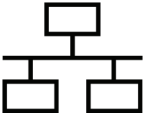







When you see ...	Then ...
 CAUTION	Follow the instruction below the symbol to avoid analyzer damage and failure, or unreliable analysis results.
NOTE	Follow the instruction below the symbol. The symbol highlights the important information in operating procedures that calls for special attention.
	Puncture Warning: The sampling probe is sharp and may contain biohazardous materials. Special care should be taken when working with it.
	Laser Warning: This sign serves as a reminder of laser radiation.







The analyzer or the outer packaging may have the following labels or symbols.

NOTE

- If the labels are damaged or missing, please contact Dymind or Dymind’s agents for replacement.
- All illustrations in this manual are provided as references only. All illustrations in this manual are provided as references only. They may not necessarily reflect actual analyzer configuration or display.

When you see ...	It means
	Caution
	Biological hazard
	Exercise caution to prevent puncture
	Laser radiation warning: It is a Class 3R laser product with 5.0mW of maximum power output at 670nm. Do not stare into the laser beam or view directly with optical instruments.
	Class 1 Laser Product

When you see ...	It means
	Instruction for moving: it reminds users that put the hands under this label and move upwards when moving.
	Computer network
	Universal Serial Bus (USB), port/plug
	Earth; ground
	Protective earth; protective ground
	Alternating current
	In Vitro diagnostic medical device
	Batch code
	Use-by date
	Serial number
	CE MARKING OF CONFORMITY
	Authorized representative in the European Community/European Union
	Date of manufacture
	Manufacturer
	Temperature limit
	Humidity limitation
	Atmospheric pressure limitation
	Consult instructions for use or consult electronic instructions for use
	Keep away from sunlight

When you see ...	It means
	Keep dry
	Distribution packages shall not be rolled or turned over.
	Stacking limit by number
	This is the correct upright position of the distribution packages for transport and/or storage.
	Contents of the distribution packages are fragile therefore it shall be handled with care.
	General symbol for recovery/recyclable
	Marking of electrical and electronic equipment in accordance with Article 11(2) of Directive 2002/96/EC(WEEE)

1.6 Safety Information



- All the samples, controls, calibrators, reagents, wastes and areas in contact with them are potentially biohazardous. Wear proper personal protective equipment (e.g. gloves, lab uniforms, etc.) and follow laboratory safety procedures when handling them and the relevant areas in the laboratory.
- If leak happens to the analyzer, the leak liquid is potentially biohazardous.



WARNING

- Please check the firmness of all the door/ covers/panels before running the analyzer to prevent unexpected opening or loosening when the analyzer is working.
 - Make sure all the safety measures are taken. Do not disable any safety device or sensor.
 - Please respond to any alarm and error message immediately.
 - Do not touch the moving parts.
 - Contact Dymind or Dymind-authorized agents upon the identification of any damaged part.
 - Be careful when opening/closing and removing/installing the doors, covers and panels of the analyzer.
 - Dispose the analyzer according to government regulations.
-



CAUTION

- Please use the analyzer in strict accordance with this manual.
 - Please take proper measures to prevent the reagents from being polluted.
-

2 Installation

2.1 Introduction



WARNING

Installation by personnel not authorized or trained by Dymind may cause personal injury or damage to the analyzer. Do not install the analyzer without the presence of Dymind-authorized personnel.

Your analyzer has passed strict tests before it is shipped from the factory. Internationally-recognized symbols and instructions show the carrier how to properly handle this electronic instrument in transportation. When you receive your analyzer, carefully inspect the packaging. If you see any sign of mishandling or damage, contact our customer service department or your local agent immediately.

2.2 Installation Personnel

The analyzer should only be installed by Dymind or its authorized agents. You need to provide the appropriate environment and space. When the analyzer needs to be relocated, please contact Dymind or your local agents.

When you receive the analyzer, please notify Dymind or your local agent immediately.

2.3 Installation Requirements



WARNING

- Connect only to a properly grounded outlet.
 - Before turning on the analyzer, make sure the input voltage meets the requirements.
-



CAUTION

- Using a patch board may introduce electrical interference and generate incorrect analysis results. Please place the analyzer near the electrical outlet to avoid using the patch board.
 - Please use the original electrical wires shipped with the analyzer. Using other electrical wires may damage the analyzer or generate incorrect analysis results.
-

Installation requirements for the analyzer are as follows.

Installation Environment	Requirements
Site	<ul style="list-style-type: none"> ● Level ground and stable workbench with load capacity $\geq 50\text{kg}$. ● Free of dust, mechanical vibration, heat and wind sources, contamination, heavy-noise source or electrical interference. ● Avoid direct sunlight and keep good ventilation. ● It's recommended to evaluate the electromagnetic environment of the laboratory before operating the analyzer. ● Keep the analyzer away from sources of strong electromagnetic interference, otherwise, its proper functioning may be affected.
Space (In addition to the space required for the analyzer itself, set aside:)	<ul style="list-style-type: none"> ● At least 50 cm from each side, which is the preferred access to perform service procedures. ● At least 20 cm from the back for cabling and ventilation. ● Enough room on and below the countertop to accommodate for the diluent and waste containers. ● Place the analyzer near the electrical outlet and avoid being blocked by any objects, so that you can disconnect the power plug easily as required.
Temperature	15°C~30°C
Relative humidity	20%~90%
Operating atmospheric pressure	70kPa~106kPa
Ventilation	Keep air exchange to ensure good air circulation. The wind should not blow directly at the analyzer.
Power Requirements	AC100V~240V, Input Power $\leq 200\text{VA}$, 50/60HZ.
Electromagnetic Wave	Keep the analyzer away from electric-brush motors, flashing fluorescent and electric-contact equipment which is switched on/off frequently.
Waste Disposal	Dispose of the waste as per the requirements of the local environment protection authorities.

2.4 Damage Inspection

Before packing and shipping, Dymind has applied rigid inspection on the analyzer. Upon receiving the analyzer, please check carefully before unpacking to see if there are any of the following damages:

- The outer packaging is placed upside down or distorted.
- The outer packaging shows obvious signs of having been exposed to humid conditions.
- The outer packaging shows obvious signs of having been crashed.
- The outer packaging shows signs of having been opened.

Once you find the above damages, please notify your local agent immediately.

If the packaging is intact, please open the packaging in the presence of personnel from Dymind or its agents and apply the following inspections:

- Check if all the items listed in the packing list are in the packaging.
- Carefully inspect the appearance of all the items to check if they are damaged or distorted.

2.5 Unpacking

Please unpack the analyzer by taking the following steps:

1. Open the outer packing box; take out the accessory pack; take out the analyzer together with the protective and cushioning materials.
2. Remove the foam and the protective PE bag.
3. Open the right door (open the linear-shaped cam lock on the right door with a slotted screwdriver).
4. Remove the binder clips, which are used for fixating two conveyor belts.
To avoid the possible collision resulting from the slippage caused by shaking and slanting during transportation, the central position of those two belts is fixated with binder clips before they are shipped from the factory. The binder clips must be removed during unpacking.
5. Remove the binder clips, which are used for fixating sampling assembly.

NOTE

To avoid damage during the transportation, the sampling assembly of the analyzer is fixated with clamps. Do remove the clamps before using the analyzer.

2.6 Connecting the Analyzer System

2.6.1 Electrical Connections

Please refer to Figure 2-1 for the electrical connections of the analyzer.

Figure 2-1 Connecting the electrical devices

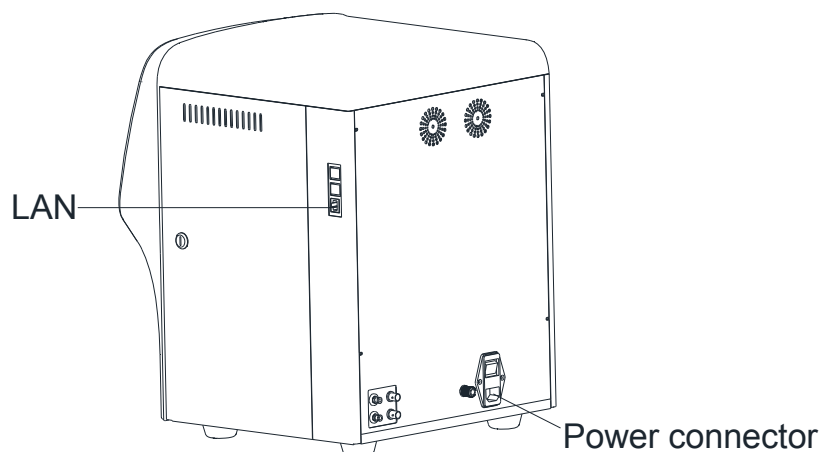

2.6.2 Reagent Connections



WARNING

- Be sure to dispose of reagents, waste, samples, consumables, etc. according to local legislations and regulations.
- Reagents can be irritating to the eyes, skin, and mucosa. Wear proper personal protective equipment (e.g. gloves, lab uniforms, etc.) and follow laboratory safety procedures when handling them in the laboratory.
- If the reagent accidentally comes in contact with your skin, wash it off immediately with plenty of water and see a doctor if necessary. Do the same if you accidentally get any of the reagent in your eyes.



CAUTION

- Please make sure the length of the diluent pipe and the waste pipe should be no longer than 1500mm; the length of the lyse pipe and the cleanser pipe should be no longer than 850mm.
- Tighten the panel connector of the fluidic line so that the overall fluidic line is closed to prevent leakage and seepage caused by siphonage, etc.

Refer to Figure 2-2 for the connection of the reagents placed outside the analyzer.

Figure 2-2 Connecting reagents placed outside the analyzer

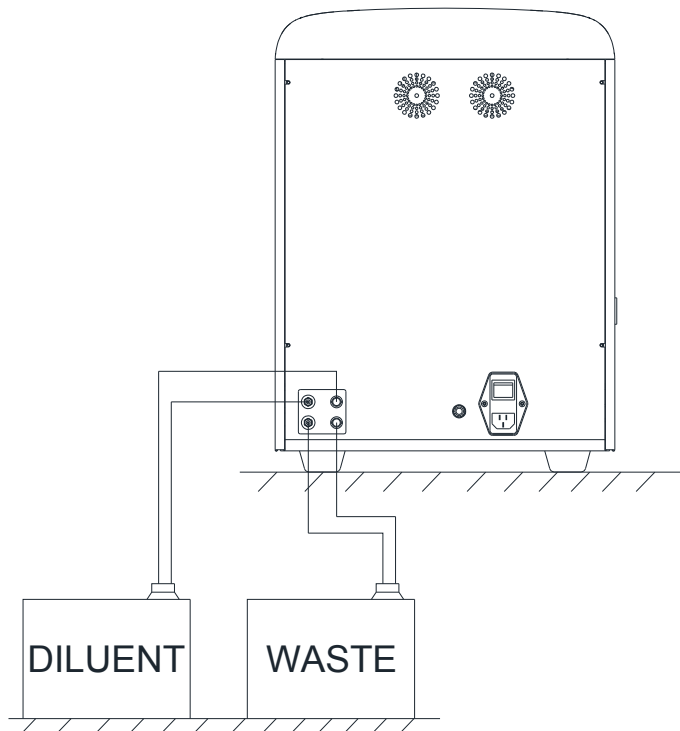

Refer to Figure 2-3 for the connection of the reagent placed inside the analyzer.

Figure 2-3 Connecting reagents placed inside the analyzer (left door opened)

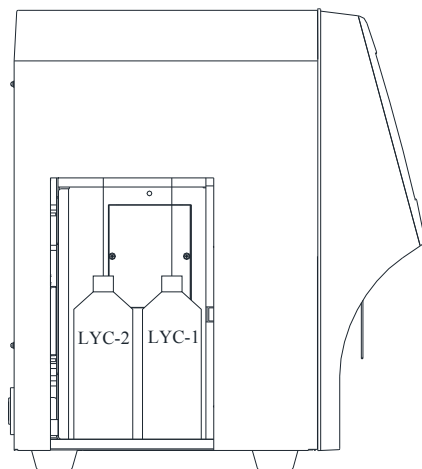

2.6.3 Installing the Diluent Float Sensor and Replacing the Reagents

Please install the diluent float sensor and replace the diluent as per the approaches stated in this section.

2.6.3.1 Installing the Diluent Float Sensor

Install the diluent float sensor according to the following steps.

1. Press down and remove the round cardboard with dotted cutting line on the top side of the diluent box so as to reveal a round hole.
2. Pull out the cover of the container so that the cardboard around the round hole can seize the neck under the vial cap to prevent invagination.
3. Turn and open the cap (keep the cap) and prevent any foreign objects from getting into the container.
4. Install the diluent float sensor assembly in the accessory pack as shown in Figure 2-4. The float sensor shall be kept as vertical as possible during installation and the self-contained cap of the sensor shall be tightened.

Figure 2-4 Installing the Diluent Float Sensor

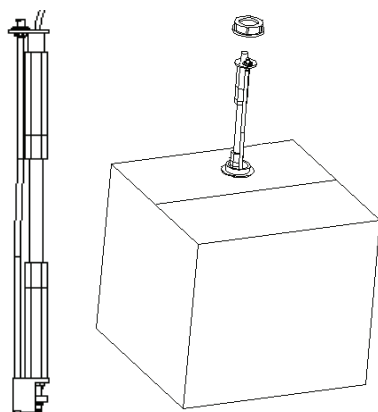

2.6.3.2 Replacing Reagents

Steps for the replacing the diluent are the same as that for installing the sensor. Please keep the empty diluent container and the cap for future use.

2.6.4 Installing the Waste Float Sensor

NOTE

The float sensors used in the analyzer are only applicable to Dymind-supplied waste containers or the containers with the same specification and model (such as the vacant diluent container).

1. Take a proper waste container (it can be a vacant diluent container, the opening of which is required to be pulled out of the hole of the box to expose the opening) and open the vial cap.
2. Install the waste float sensor assembly in the accessory pack as shown in Figure 2-5. The float sensor shall be kept as vertical as possible during installation and the self-contained cap of the sensor shall be tightened at the same time to prevent the spilling of the waste.

Figure 2-5 Installing the Waste Float Sensor

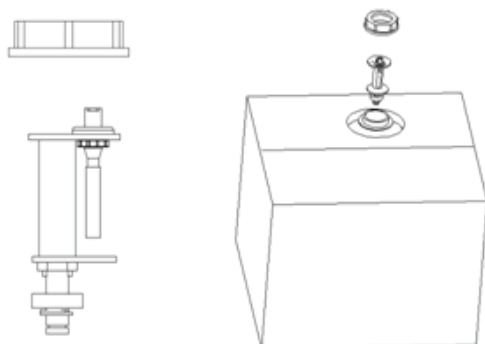

The waste container can be replaced according to the steps mentioned above. The replaced waste shall be properly disposed to avoid contamination.

**WARNING**

Be sure to dispose of reagents, waste, samples, consumables, etc. according to local legislations and regulations.

2.6.5 Connecting the LIS

If the analyzer needs to be connected to laboratory information system (hereinafter referred to as LIS), you can complete the connection by following the steps in this section.

2.6.5.1 Installing LIS Workstation

1. Install LIS workstation and set instrument type and model.
2. Enter LIS workstation network setup interface after installation and set monitoring IP address and port number.

NOTE

Please contact the Dymind customer engineer to get *Description of LIS Communication Protocol for Dymind Hematology Analyzers* to complete the support of the LIS workstation to the LIS communication protocol.

2.6.5.2 Host Communication Settings

1. Use a network cable to connect the analyzer to LIS local area network.
2. Please log on the auto hematology analyzer software as the administrator; if the analyzer is turned on, skip this step.

For detaild, see **6.3 Startup**.

The whole process lasts for 4 to 12 minutes. Please be patient.

3. In the **Setup** interface, click **Host Communication** in the **Communication** selection to access the Laboratory Information System (LIS) communication setting interface.

See Figure 2-6.

Figure 2-6 Host Communication Settings

Host Communication

You can get IP settings assigned automatically if your network supports this capability. Otherwise, you need to ask your network administrator for the appropriate IP settings.

Obtain an IP address automatically

Use the following address:

IP Address	. . .
Subnet mask	. . .
Default gateway	. . .

Obtain DNS server address automatically

Use the following DNS server addresses:

Preferred DNS server	. . .
Alternate DNS server	. . .

4. Set the IP address and other network information of the analyzer according to the actual situation.
 - If the network is accessed through a router on the site, please select **Obtain an IP address automatically** and **Obtain DNS server address automatically**.
 - If the network is accessed through a network switch, or the analyzer is directly connected to the LIS on the site, please select **Use the following address**, so as to manually set the IP address and subnet mask of the analyzer. The IP addresses of the analyzer and LIS must be in the same network segment. Furthermore, their subnet masks shall be the same, while other parameters can maintain null.

For detailed parameter descriptions, see **5.6.1 Host Network Settings**.

5. Click **OK** to save the settings and close the dialog box.

2.6.5.3 Connecting Analyzer with LIS

1. Please log on the auto hematology analyzer software as the administrator; if the analyzer is turned on, skip this step.

For detaild, see **6.3 Startup**.

The whole process lasts for 4 to 12 minutes. Please be patient.

2. In the **Setup** interface, click **LIS Communication** in the **Communication** selection to access the Laboratory Information System (LIS) communication setting interface.

See Figure 2-7.

Figure 2-7 LIS Communication Settings

3. Input the IP address and port of LIS workstation in **Network Settings** area.

Find the IP address and port of LIS in the network setup interface in the LIS workstation; if IP address can't be found, try the method below:

- a. Enter the operating system of LIS workstation.
- b. Press combination key [Windows+R] to open the **Run** window.
- c. Input **cmd**, and then click **OK**.
- d. Input the **ipconfig** command into the cmd.exe window popped out.

The interface shows similar content as follows:

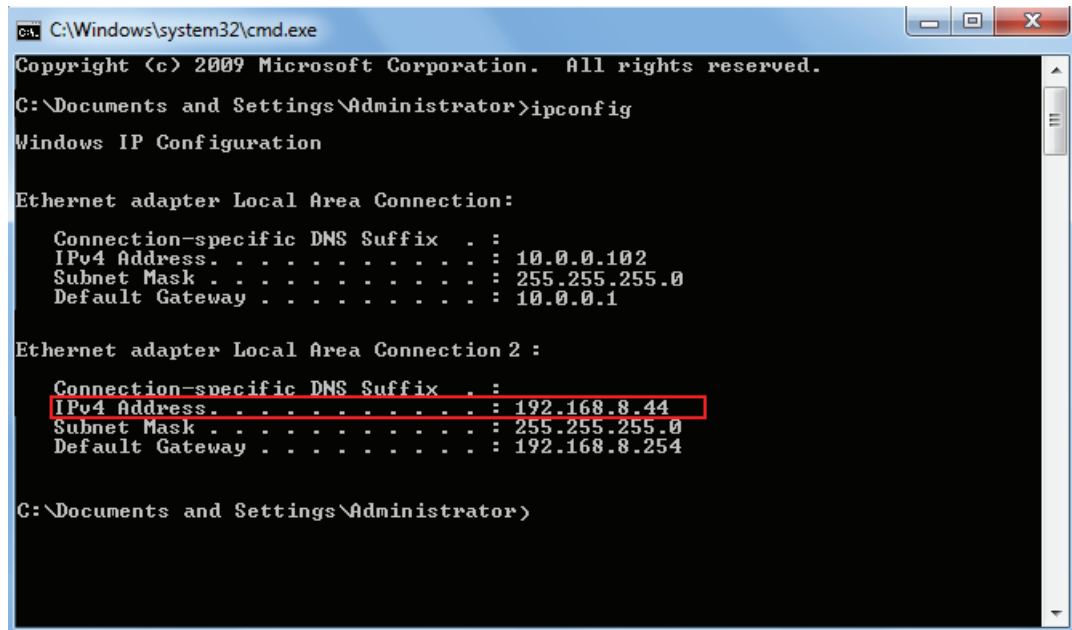

```

C:\Windows\system32\cmd.exe
Copyright (c) 2009 Microsoft Corporation. All rights reserved.

C:\Documents and Settings\Administrator>ipconfig

Windows IP Configuration

Ethernet adapter Local Area Connection:

    Connection-specific DNS Suffix  . : 
    IPv4 Address. . . . . : 10.0.0.102
    Subnet Mask . . . . . : 255.255.255.0
    Default Gateway . . . . . : 10.0.0.1

Ethernet adapter Local Area Connection 2 :

    Connection-specific DNS Suffix  . : 
    IPv4 Address. . . . . : 192.168.8.44
    Subnet Mask . . . . . : 255.255.255.0
    Default Gateway . . . . . : 192.168.8.254



C:\Documents and Settings\Administrator>
  
```

The IPv4 address in the red box is the IP address of LIS workstation.

NOTE

- The IP address **192.168.8.44** of the LIS workstation shown as above is used as an example, real IP should be in the same network segment with LIS server.
- Refer to Table 5-5 for other parameters.

4. Click **OK** to save the settings.
5. Check if the connection is successful.

The LIS icon in the upper right side on the analyzer screen turns from gray  to black , which indicates auto hematology analyzer software is connected to LIS successfully.

If the icon stays gray, the connection fails. Please check if the IP address and port of LIS is correct and reconnect as the steps above; if the problem still exists, please contact the hospital network administrator or Dymind customer service engineer to handle it.

2.7 Installing Thermal Paper (for DF52, DF55 and DF56 only)



CAUTION

- Use only specified thermal paper. Otherwise, it may cause damage to the thermal printer head, or the printer may be unable to print, or poor print quality may result.
- Never pull the thermal printer paper with force when a recording is in process. Otherwise, it may cause damage to the thermal printer.
- Do not leave the thermal printer door open unless you are installing paper or removing error.
- Improper installation of thermal printer paper may jam the paper and/or result in blank printout.

NOTE

Remove the protective paper between the thermal printer head and the roller inside the thermal printer before installing thermal paper for the first time.

Follow the procedure below to install the thermal paper.

1. Use the latch (as shown in Figure 2-8) at the upper right corner of the thermal printer door to pull the door open.

Figure 2-8 Installing Thermal Paper (1)



2. Insert a new roll into the compartment as shown below.

Figure 2-9 Installing Thermal Paper (2)

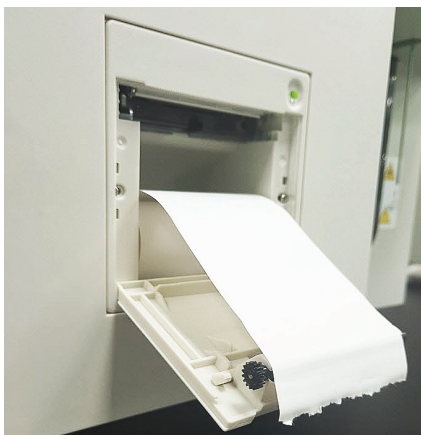

3. Close the thermal printer door.

4. Check if paper is installed correctly and the paper end is feeding from the top.

Figure 2-10 Installing Thermal Paper (3)



5. To ensure the normal use of the thermal paper, press the feed key to start paper feeding, and then press the feed button again to stop feeding when a short paper is sent out

3 System Overview

3.1 Introduction

Auto Hematology Analyzer is a quantitative, automated hematology analyzer and 5-part differential counter used in clinical laboratories.

This section describes in details the intended use, measurement parameters, structure, user interface and compatible reagents of the analyzer.

3.2 Who Should Read This Manual

It's intended for blood cell counting, 5-part classification of white blood cell and hemoglobin concentration measurement in clinical examinations.

NOTE

The analyzer is intended for screening in the clinical examination. When making clinical judgment based on the analysis results, the doctors should also take into consideration the clinical examination results or other test results.

3.3 Measurement Parameters

The analyzer performs sample analysis for different parameters according to different measurement modes (CBC or CBC+DIFF).

- For DF50, DF51 and DF53: In CBC+DIFF mode, the analyzer provides quantitative analysis results for 27 parameters (including 23 hematology parameters and 4 research parameters), 3 histograms, and 4 DIFF scattergrams (including one BASO scattergram and three DIFF scattergrams).
- For DF52, DF55 and DF56: In CBC+DIFF mode, the analyzer provides quantitative analysis results for 31 parameters (including 25 hematology parameters and 6 research parameters), 3 histograms, and 4 DIFF scattergrams (including one BASO scattergram and three DIFF scattergrams).
- In CBC mode, the analyzer provides quantitative analysis results for 13 hematology parameters, 3 histograms, and one BASO scattergram.

Refer to the table below for the detailed parameters.

Type	Parameter Name	Abbreviation	CBC	CBC+DIFF
WBC (15 or 17 items)	White Blood Cell count	WBC	*	*
	Percentage of Neutrophils	Neu%	/	*

Type	Parameter Name	Abbreviation	CBC	CBC+DIFF
	Percentage of Lymphocytes	Lym%	/	*
	Percentage of Monocytes	Mon%	/	*
	Percentage of Eosinophils	Eos%	/	*
	Percentage of Basophils	Bas%	/	*
	Number of Neutrophils	Neu#	/	*
	Number of Lymphocytes	Lym#	/	*
	Number of Monocytes	Mon#	/	*
	Number of Eosinophils	Eos#	/	*
	Number of Basophils	Bas#	/	*
	Percentage of Abnormal Lymphocytes	ALY% (RUO)	/	*
	Percentage of Large Immature Cells	LIC% (RUO)	/	*
	Percentage of Nucleated Red Cells (for DF52, DF55 and DF56 only)	NRBC% (RUO)	/	*
	Number of Abnormal Lymphocytes	ALY# (RUO)	/	*
	Number of Large Immature Cells	LIC# (RUO)	/	*
	Number of Nucleated Red Cells (for DF52, DF55 and DF56 only)	NRBC# (RUO)	/	*
RBC (8 items)	Red Blood Cell count	RBC	*	*
	Hemoglobin Concentration	HGB	*	*
	Mean Corpuscular Volume	MCV	*	*
	Mean Corpuscular Hemoglobin	MCH	*	*
	Mean Corpuscular Hemoglobin Concentration	MCHC	*	*
	Red Blood Cell Distribution Width - Coefficient of Variation	RDW-CV	*	*
	Red Blood Cell Distribution Width - Standard Deviation	RDW-SD	*	*
	Hematocrit	HCT	*	*
PLT (4 or 6 items)	Platelet count	PLT	*	*
	Mean Platelet Volume	MPV	*	*
	Platelet Distribution Width	PDW	*	*
	Plateletcrit	PCT	*	*
	Platelet-large cell ratio (for DF52, DF55 and DF56 only)	P-LCR	*	*
	Platelet-large cell count (for DF52, DF55 and DF56 only)	P-LCC	*	*
Histogram	White Blood Cell Histogram	WBC Histogram	*	*

Type	Parameter Name	Abbreviation	CBC	CBC+DIFF
(3 items)	Red Blood Cell Histogram	RBC Histogram	*	*
	Platelet Histogram	PLT Histogram	*	*
Scattergram	Differential Scattergram	DIFF Scattergram	/	*
	Basophils Scattergram	BASO Scattergram	*	*

NOTE

- “*” means the parameter is provided in the mode. “/” means the parameter is not provided.
- ALY%, LIC%, NRBC%, ALY# , LIC# and NRBC# are parameters for research use only (RUO), not for diagnostic use.
- The NRBC#, NRBC%, P-LCR and P-LCC are parameters for DF52, DF55 and DF56 only.

3.4 Structure of the Analyzer

**WARNING**

- Please check the firmness of all the doors, covers and boards before running the analyzer.
- The analyzer is heavy, so moving by one person alone may cause injury. It is advisable for two people to move it together when the transportation is necessary, and make sure you follow the instructions and use the proper tools.
- Connect only to a properly grounded outlet.
- To avoid electrical shocks, disconnect the power supply before opening the cover.
- To prevent fire, use the fuses with specified model number and working current.



The sampling probe is sharp and may contain biohazardous materials. Special care should be taken when working with it.



This sign warns of laser radiation. Do not look directly at the laser beams or see through the optical instrument.

3.4.1 Main unit

The Auto Hematology Analyzer consists of the main unit (analyzer) and accessories. The main unit is the main part for analysis and data processing.

- Front of the analyzer

Figure 3-1 Front of the analyzer

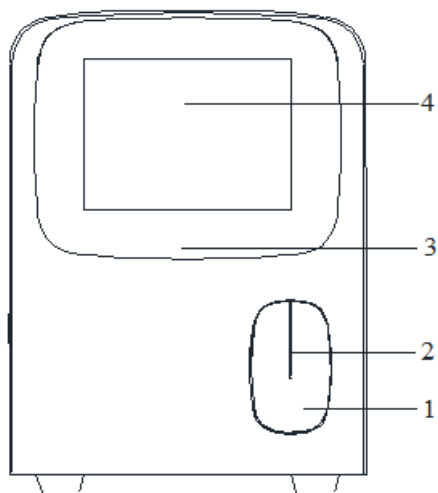

- | | |
|---------------------------|-----------------|
| 1: Aspirate key | 2: Sample probe |
| 3: Power/Status indicator | 4: Touch screen |

- Back of the analyzer

Figure 3-2 Back of the analyzer

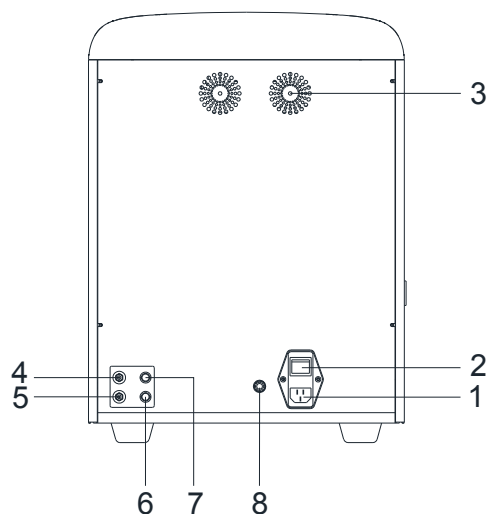

- | | |
|-----------------------------------------|------------------------------------|
| 1: AC input | 2: Power switch |
| 3: Cooling fan | 4: Diluent inlet |
| 5: Waste outlet | 6: Waste level detection connector |
| 7: Diluent presence detection connector | 8: Ground studs |

- Side view of the analyzer

Figure 3-3 Side view of the analyzer

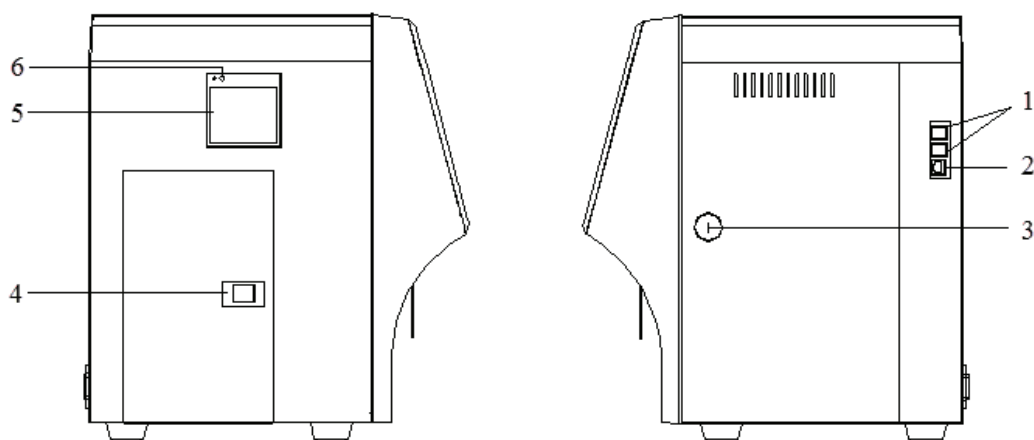

1: USB interface

2: Network interface

3: Right side door buckle

4: Left side small door buckle

5: Thermal printer

6: Paper feed key

NOTE

The thermal printer on the left side of the analyzer is for DF52, DF55 and DF56 only.

3.4.2 Touch screen

The touch screen is located on the front side of the analyzer for performing interface operations and displaying the information.

3.4.3 Aspirate key

The aspirate key is located in the middle of the front side (behind the sample probe) to start the sample analysis, to add diluent, or to cancel sleep.

3.4.4 Power/Status indicator

The status indicator is located in the middle section of the right part of the analyzer (front side). It shows the status of the analyzer including ready, running, error, sleep and on/off, etc.

The indicators change with the status of the main unit. Details are shown in Table 3-1.

Table 3-1 Main Unit Status Indicators

Instrument Status	Indicator Status	Remarks
Shutdown	Off	The main unit has been shut down.
Stopped running with error conditions	Red light on	Stopped running with the occurrence of errors.

Instrument Status	Indicator Status	Remarks
Running with error conditions	Red light flickering	Running with the occurrence of errors.
Time sequence deactivated	Yellow light on	Initialization or sleep status irrelevant to running.
Running	Green light flickering	Execution of the sequence actions is in process.
Ready	Green light on	Execution of the sequence actions is allowed.

NOTE

While the analyzer is running, if the indicator turns dim or off, please contact Dymind or Dymind's agent for maintenance.

3.4.5 Paper Feed Key (for DF52, DF55 and DF56 only)

The paper feed key is located on the left side of the analyzer. After you press it, the built-in thermal printer will send out the paper with records.

3.4.6 Thermal Printer (for DF52, DF55 and DF56 only)

The thermal printer is located on the left side of the analyzer. It will send out the paper with records after you press the paper feed key.

3.4.7 Power switch

**CAUTION**

To avoid damage, do not power on/off the analyzer repetitively within a short time.

A power switch is located in the bottom back of the analyzer. It turns on or shuts down the analyzer.

3.4.8 USB interface

The USB interface is located on the right side of the main unit. There are 4 interfaces in total for external equipment (printer, barcode scanner, mouse or keyboard, and so on) connection or data transmission.

3.4.9 Network interface

The network interface is located on the right side of the main unit. There is 1 network interface in total for connecting with the Ethernet.

3.4.10 External Equipment (Optional)

The analyzer can be connected with the following external equipment:

- Keyboard
The keyboard is connected with the USB interface on the right side of the analyzer for controlling the analyzer.
- Mouse
The mouse is connected with the USB interface on the right side of the analyzer for operations on the analyzer.
- Printer
The printer is connected with the USB interface on the right side of the analyzer for printing reports and other information displayed on the screen.
- Barcode Scanner
The barcode scanner is connected with the USB interface on the right side of the analyzer for entering barcode information in an easy and fast way.
- USB flash disk
The USB flash disk is connected with the USB interface on the right side of the analyzer for exporting sample data.

3.5 User Interface

After the startup procedure, you will enter the user interface (**Sample Analysis** as default). See Figure 3-4.

Figure 3-4 User Interface

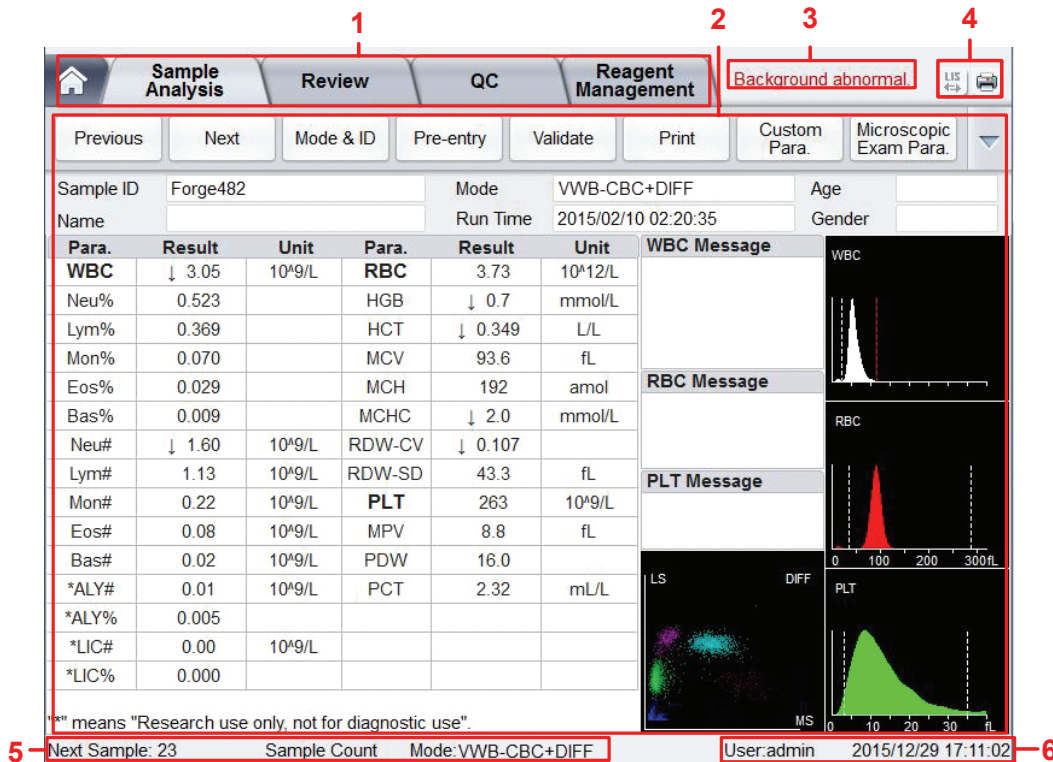

The interface can be divided into several areas as follows according to their functions:

- 1 - Menu navigation area

On the top of the screen is the menu navigation area. Once a menu button is pressed, the system goes immediately to the corresponding screen.

- 2 - Menu content display area

It displays the selected screen and the corresponding function buttons.

- 3 - Error message area





Upon the occurrence of a system failure, the corresponding error message will appear in this area. When there is more than one failure, the error message for the latest failure will appear in this area.

Click in this area, you can deal with the failures in the popup dialog box of troubleshooting help. For more information, see **13 Troubleshooting**.

- 4 - Status display area

On the top right of the screen is the status display area where the connection status between the analyzer and the LIS system and printer status are displayed from left to right. The icons change with the status of the main unit, as shown in Table 3-2.

Table 3-2 Status Icon Description

Status	Icon	Remarks
LIS/HIS status	Gray icon 	The computer is not connected to the LIS/HIS.
	Black icon 	The computer is connected to the LIS/HIS.
Print status	Gray icon 	The external printer is not connected to the analyzer yet.
	Color icon 	The external printer is connected to the analyzer.

- 5 - Information area of the next sample

This area displays the information about the sample ID, sample position, blood mode (whole blood/predilute) and measurement mode (CBC/CBC+DIFF) of the next sample.

- 6 - Current user, date and time of the analyzer.

3.6 Reagents, Controls and Calibrators

Because the analyzer, reagents, controls, and calibrators are components of the system, system performance depends on the combined integrity of all the components. You should only use the Dymind-specified reagents (see **A.2 Reagents**), which are formulated specifically for the fluidic system of your analyzer in order to achieve optimal system performance. Do not operate the analyzer using reagents from multiple suppliers. Under such circumstances, the analyzer may not achieve the performance specified in this manual and may generate unreliable results. All references to “reagents” in this manual refer to the reagents specifically formulated for this analyzer.

Each reagent package should be examined before use. Inspect the package for signs of leakage or

moisture. If there is evidence of leakage or improper handling, do not use the reagent.

NOTE

- After long-distance transportation, the reagent must be allowed to settle for more than one day before use.
 - Store and use the reagents by following the instructions for use of the reagents.
 - When you have changed the diluents or lysers, run a background check to see if the results meet the requirement.
 - Pay attention to the expiration dates and open-container stability days of all the reagents. Be sure not to use expired reagents.
-

3.6.1 Reagents

The following reagents are intended to be used with the analyzer for 5-part diff counting, daily cleaning and other operations.

- DIL-C Diluent
This product is intended for sample dilution and preparation of cell suspension before running the samples.
- LYC-2 Lyse
The product is intended for lysing the red blood cells and white blood cell classification.
- LYC-1 Lyse
This product is intended for lysing the red blood cells, determining the hemoglobin, white blood cell classification and counting the total number of white blood cells.
- CLE-P Cleanser
This product is intended for cleaning the fluidic system of the analyzer and regular instrument cleaning.

3.6.2 Controls and Calibrators

The controls and calibrators are used for quality control and analyzer calibration.

The controls are commercially prepared whole-blood products used to verify that the analyzer is functioning properly. They are available in low, normal, and high levels. Daily use of all levels verifies the normal operation of the analyzer and ensures the acquisition of reliable results. The calibrators are commercially prepared whole-blood products used to calibrate the analyzer.

Read and follow the instructions to use the controls and calibrators.

The "calibrators" and "controls" mentioned in this manual refer to Dymind-specified calibrators and controls and need to be purchased from Dymind or its specified agent.

4 Working Principle

4.1 Introduction

The measurement methods used in this analyzer are: the electrical Impedance method for determining the RBC and PLT data; the colorimetric method for determining the HGB; laser-based flow cytometry for determining the WBC data. During each analysis cycle, the sample is aspirated, diluted and mixed before the determination for each parameter is performed.

4.2 Aspiration

The analyzer supports Whole Blood mode (including **Venous Whole Blood** and **Capillary Whole Blood**) and **Predilute** mode.

In Whole Blood mode, the analyzer will aspirate quantitative whole blood sample.

In Predilute mode, the analyzer will aspirate the prediluted sample (with the dilution ratio of 1:25) which is a mixture of 20 μ L of whole blood/capillary blood sample and 480 μ L of diluent the diluted sample thus prepared is then delivered to the analyzer for sampling and aspiration.

4.3 Dilution

After being aspirated into the analyzer, the sample is divided into two parts. After the reaction with reagents in parallel dilution procedures, each part forms the sample for red blood cell/platelet, white blood cell count/hemoglobin measurement and white blood cell differential measurement.

To meet different needs, the analyzer offers two working modes (Whole Blood and Predilute), and two measurement modes (CBC and CBC+DIFF).

Taking CBC+DIFF mode as an example, this section introduces the dilution procedures of the test sample in Whole Blood mode and Predilute mode separately. (The dilution procedure in CBC mode is not introduced here since it's the same as that in CBC+DIFF mode.)

NOTE

CBC mode, namely complete blood cell count, is intended for counting only, not for white blood cell classification. CBC+DIFF mode is intended for both counting and white blood cell classification.

4.3.1 Dilution Procedure in Whole-blood CBC+DIFF Mode

Dilution Procedures in Whole-Blood CBC+DIFF Mode are shown in Figure 4-1.

Figure 4-1 Dilution Procedure in Whole-blood CBC+DIFF Mode

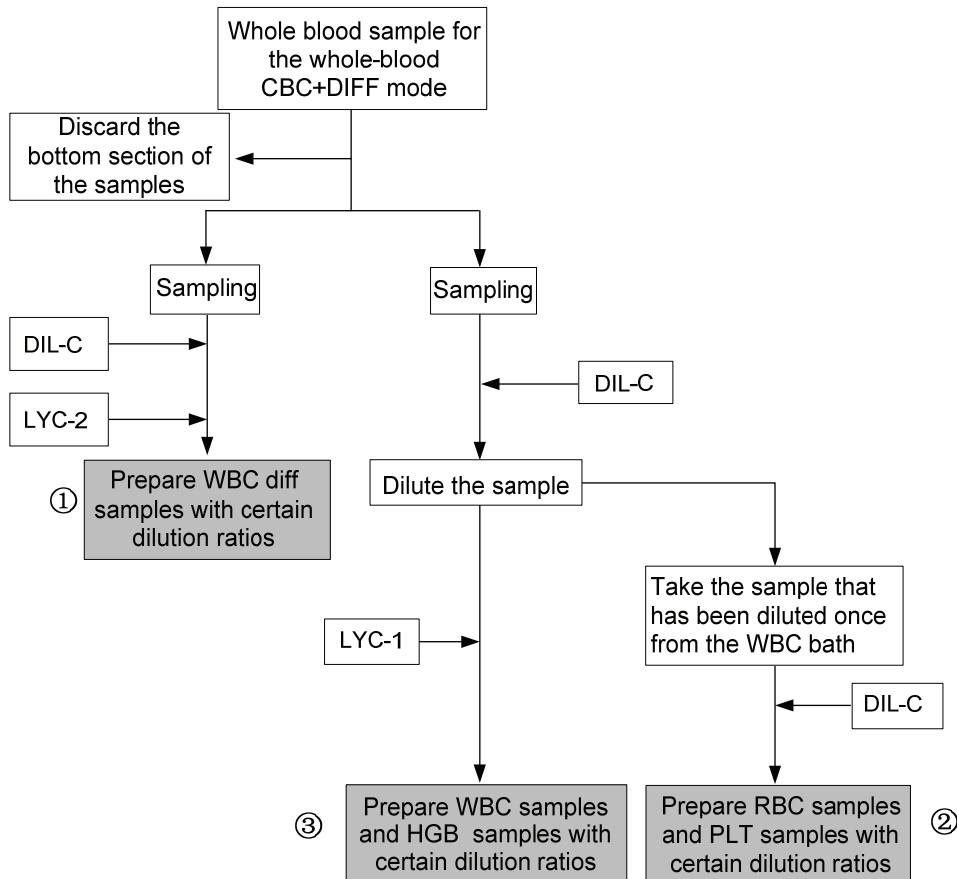

Where,

- ① is the dilution procedure for white blood cell diff, namely DIFF;
- ② is the dilution procedure for red blood cell and platelet;
- ③ is the dilution procedure for white blood cell count/hemoglobin; namely CBC.

4.3.2 Dilution Procedure in Predilute CBC+DIFF Mode

In CBC+DIFF mode, the dilution procedure for the prediluted sample is shown in Figure 4-2.

Figure 4-2 Dilution Procedure in Predilute CBC+DIFF Mode

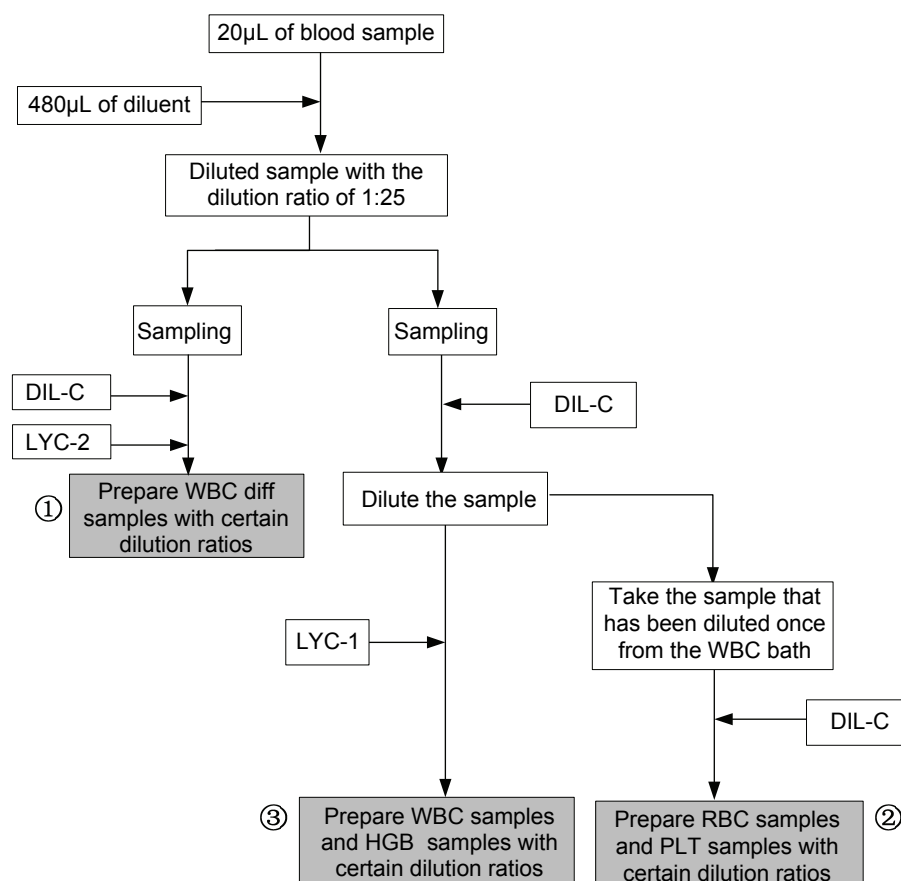

Where,

- ① is the dilution procedure for white blood cell diff, namely DIFF;
- ② is the dilution procedure for red blood cell and platelet;
- ③ is the dilution procedure for white blood cell count/hemoglobin; namely CBC.

4.4 WBC Measurement

The analyzer obtains the white blood cell 5-part classification results and white blood cell count/basophils count using a semiconductor-laser-based flow cytometry, and eventually calculates the parameters relevant to white blood cells.

4.4.1 Working Principle of Laser-based Flow Cytometry

The principle of laser-based flow cytometry is illustrated by Figure 4-3.

Figure 4-3 WBC Measurement

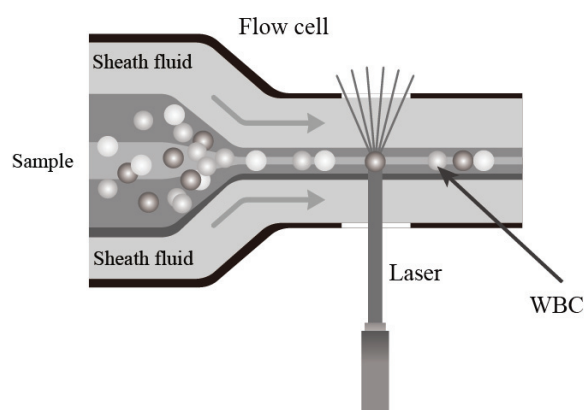

After a predetermined volume of blood is aspirated and diluted by a certain amount of reagent, it is injected into the flow chamber. Surrounded with sheath fluid (diluent), the blood cells pass through the center of the flow chamber in a single column at a faster speed. When the blood cells suspended in the diluent pass through the flow chamber, they are exposed to a laser beam. The intensity of scattered light reflects the blood cell size and intracellular density. The low-angle scattered light signal shows cell size, while the middle-angle and high-angle scattered light signal show intracellular information (nucleus and cytoplasm information). The optical detector receives this scattered signal and converts it into electrical pulses. Pulse data thus collected can be used to draw four 2-dimensional distributions (scattergrams) as shown in Figure 4-4.

Figure 4-4 DIFF channel scattergram

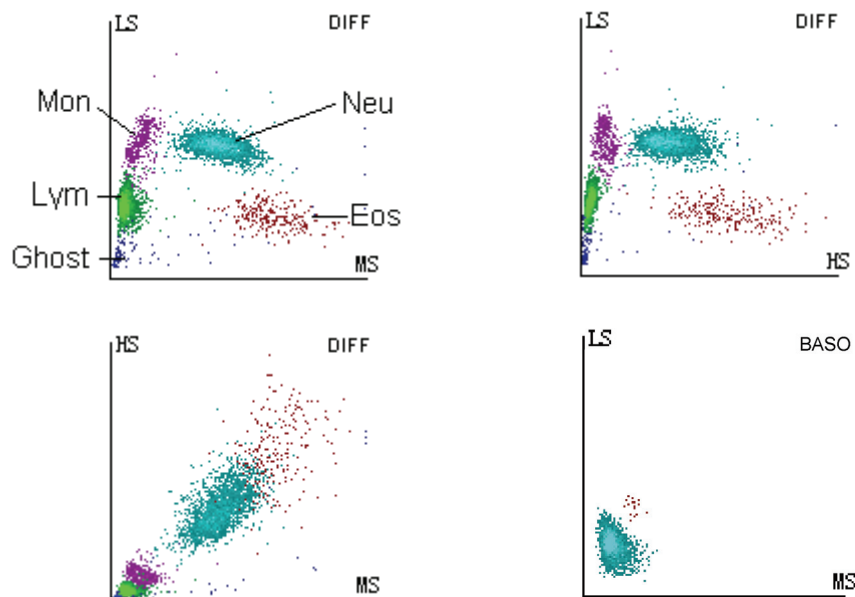

Conduct dual channel detection to the white blood cells (WBCs). Use three-angle laser scattering and flow cytometry for the count and classification of various kinds of WBCs in dual channels.

By analyzing the DIFF channel scattergram, the analyzer presents the Lym%, Mon%, Eos% and Neu%.

The independent WBC/Bas channel shall use a specific kind of hemolytic agent that can extract the Baso cell specificity, so as to reserve the complete information of Bas cells. Conduct precise and reliable WBC/Bas cell counting combined with three-angle laser scattering and flow cytometry.

4.4.2 Derivation of WBC-Related Parameters

Based on the DIFF scattergram and the analysis for the Lym zone, Neu zone, Mon zone and Eos zone, the analyzer can get the percentage of lymphocytes (Lym%), the percentage of neutrophils (Neu%), the percentage of monocytes (Mon%) and the percentage of eosinophils (Eos%), and then get the number of basophils (Bas#), the number of lymphocytes (Lym#), the number of neutrophils (Neu#), the number of monocytes (Mon#) and the number of eosinophils (Eos#) based on the calculation with the white blood cell count obtained with the working principle of laser-based flow cytometry. The unit of the number of cells is $10^9/L$.

- White Blood Cell count

WBC count is the number of leukocytes measured directly by counting the leukocytes passing through the flow chamber.

- Number of Basophils (Bas#)

Bas# is the number of Basophils measured directly by counting the basophils passing through the flow chamber.

- Percentage of Basophils (BAS%)

$$\text{Bas\%} = \frac{\text{Bas\#}}{\text{WBC}} \times 100\%$$

- Percentage of Lymphocytes (Lym%)

$$\text{Lym\%} = \frac{\text{Particles in Lym region of DIFF channel}}{\text{Sum of all particles in DIFF channel except those in Ghost region}} \times 100\%$$

- Percentage of Neutrophils (Neu%)

$$\text{Neu\%} = \frac{\text{Particles in Neu region of DIFF channel}}{\text{Sum of all particles in DIFF channel except those in Ghost region}} \times 100\%$$

- Percentage of Monocytes (Mon%)

$$\text{Mon\%} = \frac{\text{Particles in Mon region of DIFF channel}}{\text{Sum of all particles in DIFF channel except those in Ghost region}} \times 100\%$$

- Percentage of Eosinophils (EOS%)

$$\text{Eos\%} = \frac{\text{Particles in Eos region of DIFF channel}}{\text{Sum of all particles in DIFF channel except those in Ghost region}} \times 100\%$$

- Number of lymphocytes (Lym#)

$$\text{Lym\#} = \text{WBC} \times \text{Lym\%}$$

- Number of Neutrophils (Neu#)

$$\text{Neu\#} = \text{WBC} \times \text{Neu\%}$$

- Number of Monocytes (Mon#)

$$\text{Mon\#} = \text{WBC} \times \text{Mon\%}$$

- Number of Eosinophils (Eos#)

$$\text{Eos\#} = \text{WBC} \times \text{Eos\%}$$

4.5 HGB Measurement

HGB is determined by the colorimetric method.

4.5.1 Colorimetric Method

The WBC/HGB diluent is delivered to the HGB bath where it is mixed with a certain amount of lyse, which converts hemoglobin to a hemoglobin complex that is measurable at 525 nm. An LED is mounted on one side of the bath and emits a beam of monochromatic light with a central wavelength of 525nm. The light passes through the sample and is then measured by an optical sensor mounted on the opposite side. The signal is then amplified and the voltage is measured and compared with the blank reference reading (readings taken when there is only diluent in the bath).

4.5.2 HGB

The HGB is calculated using the following equation and expressed in g/L.

$$\text{HGB(g/L)} = \text{Constant} \times \text{Ln} \left(\frac{\text{Blank Photocurrent}}{\text{Sample Photocurrent}} \right)$$

4.6 RBC/PLT Measurement

The analyzer detects the red blood cell count and platelet count and their volume distribution by impedance method and eventually obtains the results of related parameters.

4.6.1 Electrical Impedance Method

RBCs/PLTs are counted and sized by the Electrical Impedance method. This method is based on the measurement of changes in electrical resistance produced by a particle, which in this case is a blood cell, suspended in a conductive diluent as it passes through an aperture of known dimensions. An electrode is submerged in the liquid on both sides of the aperture to create an electrical pathway. As each particle passes through the aperture, a transitory change in the resistance between the electrodes is produced. This change produces a measurable electrical pulse. The number of pulses thus generated is equal to the number of particles that passed through the aperture.

Figure 4-5 Electrical Impedance method

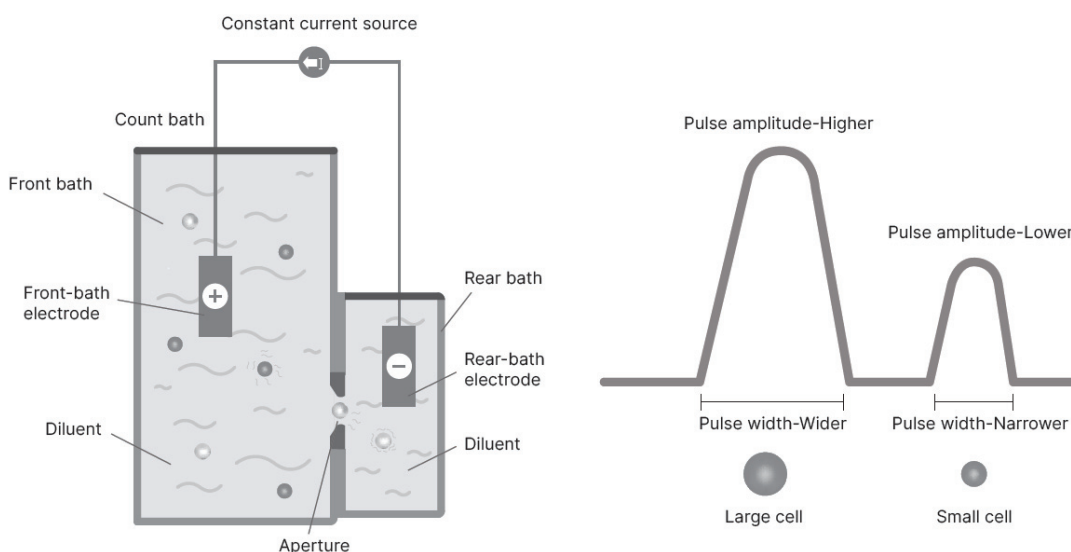

Each pulse is amplified and compared to the internal reference voltage channel, which only accepts the pulses of a certain amplitude. If the pulse generated is above the WBC/BAS lower threshold value, it is counted as a WBC/BAS. The analyzer presents the RBC/PLT histogram, where the x-coordinate represents the cell volume (fL) and the y-coordinate represents the number of the cells.

4.6.2 RBC

- Red Blood Cell count

RBC ($10^{12}/L$) is the number of erythrocytes measured directly by counting the erythrocytes passing through the aperture.

- Mean Corpuscular Volume (MCV)

Based on the RBC histogram, this analyzer calculates the MCV and expresses the result in fL.

- Hematocrit (HCT), Mean Corpuscular Hemoglobin (MCH), Mean Corpuscular Hemoglobin Concentration (MCHC)

This analyzer calculates the HCT (%), MCH (pg) and MCHC (g/L) as follows, where the RBC is expressed in $10^{12}/L$, MCV in fL and HGB in g/L.

$$HCT = \frac{RBC \times MCV}{10}$$

$$MCH = \frac{HGB}{RBC}$$

$$MCHC = \frac{HGB}{HCT} \times 100$$

- Red Blood Cell Distribution Width - Coefficient of Variation (RDW-CV)

Based on the RBC histogram, this analyzer calculates the CV (Coefficient of Variation, %) of the erythrocyte distribution width.

- Red Blood Cell Distribution Width - Standard Deviation (RDW-SD)

RDW-SD (RBC Distribution Width – Standard Deviation, fL) is obtained by calculating the standard deviation of the red blood cell size distribution.

4.6.3 PLT

- Platelet count

PLT is measured directly by counting the platelets passing through the aperture.

- Mean Platelet Volume (MPV, fL)

Based on the PLT histogram, this analyzer calculates the MPV.

- Platelet Distribution Width (PDW)

PDW is the geometric standard deviation (GSD) of the platelet size distribution. Each PDW result is derived from the platelet histogram data and is reported as 10(GSD).

- Plateletcrit (PCT)

This analyzer calculates the PCT as follows and expresses it in %, where the PLT is expressed in $10^9/L$ and the MPV in fL.

$$PCT = \frac{PLT \times MPV}{10000}$$

- Platelet-Large Cell Ratio (P-LCR)

P-LCR is obtained by PLT distribution histogram. It is the ratio of the number of platelets with volume exceeding 12fL to the total number of platelets. It is expressed in %.

- Platelet-Large Cell Count (P-LCC)

The analyzer calculates the P-LCC count according to the following formula, and expresses it in $10^9/L$.

$$P - LCC = PLT \times P - LCR$$

NOTE

The measurement of P-LCC and P-LCR is for DF52, DF55 and DF56 only.

4.7 Flushing

After each analysis cycle, each component of the analyzer is flushed.

5 Setup

5.1 Introduction

The analyzer has been initialized before delivery. The interfaces upon the initial startup of the analyzer are system settings by default. Some parameters of the analyzer can be reset to meet various demands in practical applications.

The analyzer divides the operators into two access levels, common user and administrator. Note that an administrator can access all the functions accessible to a common user. This chapter introduces how to customize your analyzer as an administrator.

5.2 Interface Introduction

After logging in the system (see **6.3 Startup**), click , and choose **Setup** to access the **Setup** interface. See Figure 5-1.

Figure 5-1 Setup

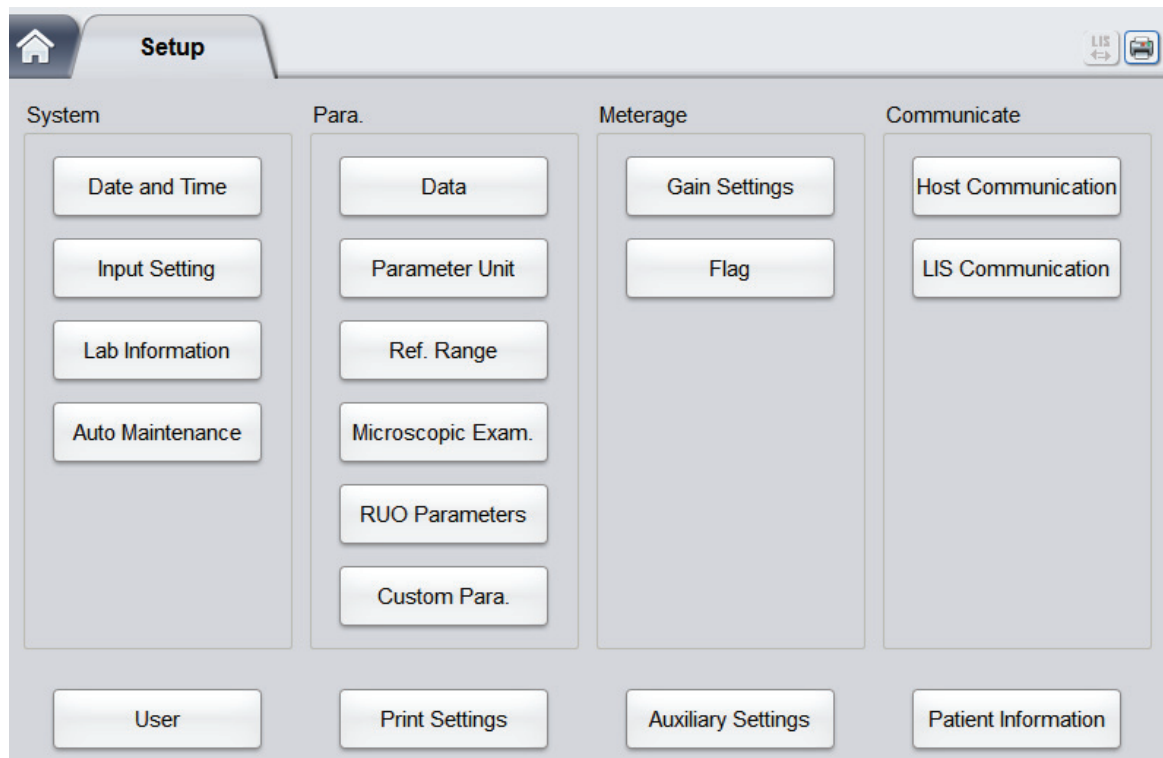

The administrator is allowed to set the following functions in the **Setup** interface:

- System settings
- Parameter settings
- Meterage settings
- LIS communication
- User management
- Print settings
- Auxiliary settings
- Patient Information
- Thermal printer setting (for DF52, DF55 and DF56 only)

5.3 System Settings

5.3.1 Date and Time

You can set the current date and time, as well as the date display format in the analyzer system. Specific steps are shown below:

1. Click **Date and Time** in the **System** area.

The date and time format setting interface pops up.

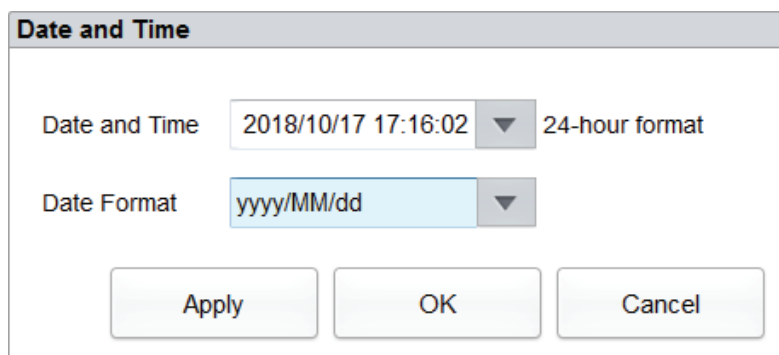

Date and Time

Date and Time 2018/10/17 17:16:02 24-hour format

Date Format yyyy/MM/dd

Apply OK Cancel

2. Click the **Date and Time** dropdown list and set the current date and time of the system in the popup dialog box.

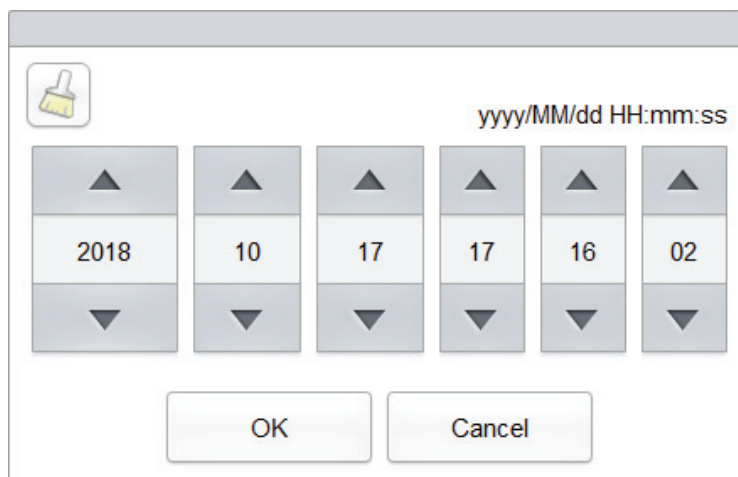



 yyyy/MM/dd HH:mm:ss

▲	▲	▲	▲	▲	▲
2018	10	17	17	16	02
▼	▼	▼	▼	▼	▼

OK Cancel

Related descriptions:

- The input sequence of the controls is the same with the date format on the top right corner of the dialog box. For example, if the data format is **yyyy/MM/dd HH:mm:ss**, you should input the data in the sequence of year, month, date, hour, minute, and second.
 - Click  or  to select a date and time or enter the information in the textbox directly.
 - Click  to clear the current data and re-enter the information.
3. Click **OK** to save and close the message box.
 4. Select the format setting from the dropdown list of the **Date Format**.

See Figure 5-2.

Figure 5-2 Setting the Date Format

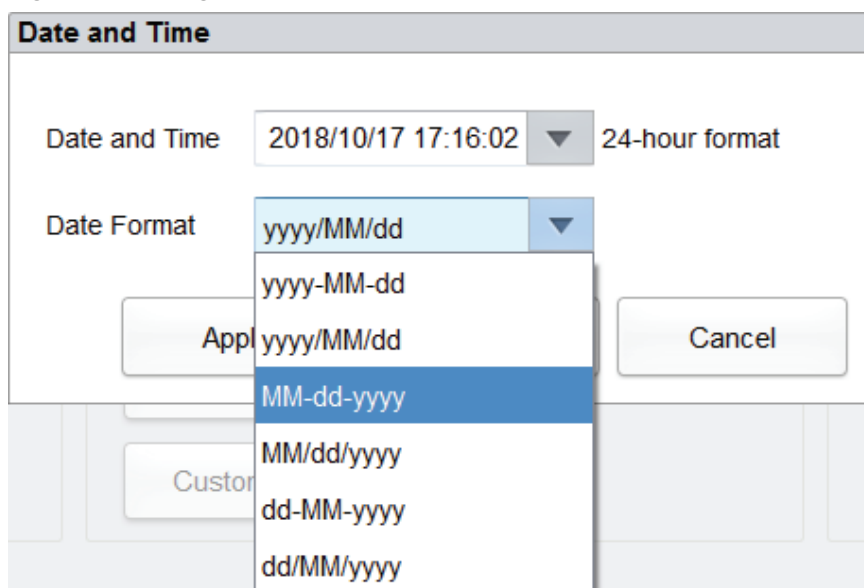

5. Click **Apply**.

The system message will pop up, indicating the successful setting. See Figure 5-3.

Figure 5-3 Successful Setting of the Date Format

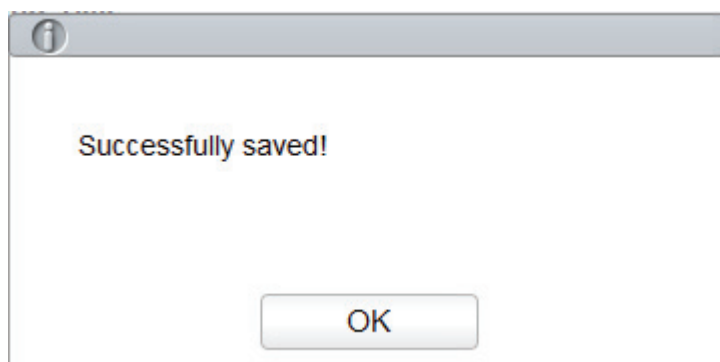

The date and time at the bottom right corner will be displayed in the newly set format as shown in **10-17-2018 17:18:22**.

6. Click **OK** to close the message box.
7. Click **OK** to exit.

5.3.2 Input Settings

Click **Input Setting** in the **System** area, and then you can set the soft keyboard for screen input. As shown in Figure 5-4, You can set to turn the soft keyboard on or off.

Figure 5-4 Input Settings

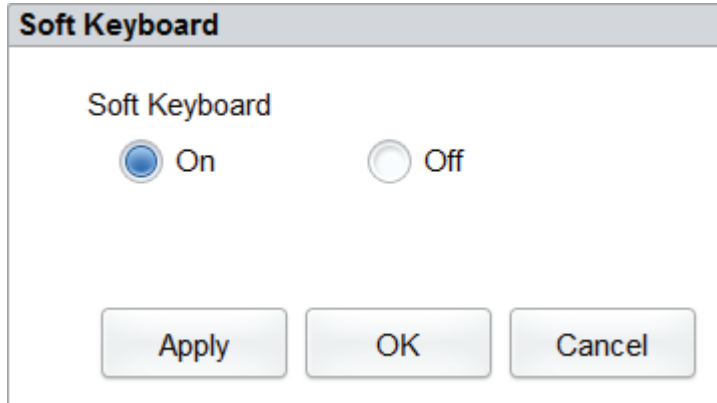

- On (default)

You can enter content using the soft keyboard popped up on the screen. Functions and applications for the keys are shown in Figure 5-5.

Figure 5-5 Soft Keyboard

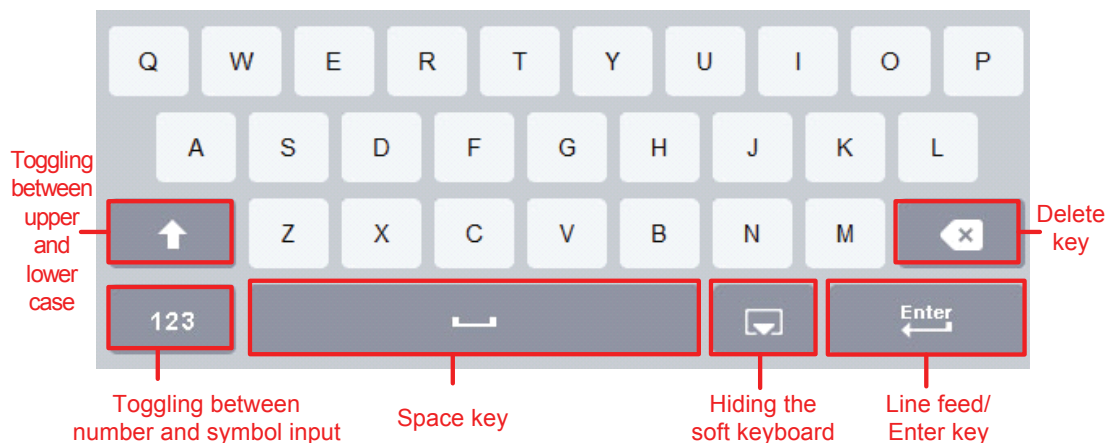

- Off

You need to use an externally connected USB keyboard for entering content.

5.3.3 Lab Information

Click **Lab Information** in the **System** selection, then you can set the lab information. See Figure 5-6.

Figure 5-6 Setting Lab Information

Lab Information

Hospital Name

Lab Name

Responsible Person

Responsible Person Contact Info

Customer Service Contact

Customer Service Contact Info

Analyzer SN

Installation Date
 ▼

Remarks

Apply OK Cancel

NOTE

Only the administrator has the access for setting the lab information. General users are only allowed to browse such information.

Refer to the table below for the detailed instructions of parameter setting.

Table 5-1 Setting Lab Information

Parameter	Setting Description
Hospital Name	Enter the name of the hospital where the lab is located.
Lab Name	Enter the lab name.
Responsible Person	Enter the responsible person of the lab.
Responsible Person Contact Info	Enter the contact information (telephone number or E-Mail) of the lab.
Customer Service Contact	Enter the name of the contact person in Service Department.
Customer Service Contact Info	Enter the contact information of the contact person in the Service Department.
Analyzer SN	Display the serial number of the analyzer. Read only.
Installation Date	Display the installation date of the analyzer. Read only.
Remarks	Enter the remarks regarding the lab.

5.3.4 Auto Maintenance

Click **Auto Maintenance** in the **System** selection to access the **Auto Maintenance** setting interface. The system auto sleep waiting time and cleanser maintenance time can be set in the **Auto Maintenance** interface.

Figure 5-7 Auto Maintenance

Auto Sleep

In the **Wait** textbox, the administrators can set the waiting time for entering the sleep state after the main unit is halted. The range is between 15 and 120 minutes and the default value is 30 minutes.

Auto Cleanser Soak

There are two ways to prompt for auto cleanser soak. They are prompt according to the time and prompt according to the sample numbers. The administrator can select one of the prompt modes as required.

- Prompt according to the time

The administrator is allowed to set the start time of the cleanser soak in the **Prompt according to the time** textbox. The acceptable value ranges from 0:00 to 23:59 and the default value is **17:00**.

- Prompt according to the sample numbers

The administrator can also choose to check the **Prompt according to the sample numbers** textbox. The default value of the total number of samples is **400** Pc/Pcs and cannot be edited.

5.4 Parameter Settings

5.4.1 Data Dictionary

You can set shortcut codes for the relevant items of the patient information.

If a shortcut code is set, the shortcut code corresponding to the above mentioned item can be entered directly when the information is input or numbered, then the complete information can be displayed without entering (or selecting) complete information. It is a shortcut operation.

Different items can share one shortcut code.

5.4.1.1 Accessing the interface

Click **Data** in the **Para.** selection to access the data dictionary setting interface. See Figure 5-8. You can set the shortcut code for the relevant items of the patient information in this interface.

Figure 5-8 Shortcut Code

Department	Name	Shortcut Code	Remarks
	Internal Medicine	Nk	
Submitter	Surgery	Wk	
Patient Type			
Gender			
Area			
Bed No.			
Sample Type			

Buttons: New, Edit, Delete, Cancel

You can set the shortcut code for the following items: **Department**, **Submitter**, **Patient Type**, **Gender**, **Area**, **Bed No.** and **Sample Type**.

5.4.1.2 Adding a New Item

This section takes the adding of a new department as an example to introduce the method for adding a new item and its shortcut code. The method for adding other new items is similar and is not introduced in details herein.

Steps for adding a new department are shown as follows:

1. Click **New** in the **Department** interface.

A dialog box will pop up as shown in Figure 5-9.

Figure 5-9 Adding a New Item

The 'New' dialog box contains three text input fields: 'Name', 'Shortcut Code', and 'Remarks'. Below these fields are two buttons: 'OK' and 'Cancel'.

2. Enter a new department name, shortcut code and remarks.

NOTE

- Newly added department name must be entered and it can not be the same as existing ones.
- The shortcut code is not necessary to be entered, but once set, every code must be unique.

3. Click **OK** to save the information about the new department.

Information about the newly added department will be displayed in the department interface. See Figure 5-10.

Figure 5-10 Information of the Newly Added Department

The 'Data' interface displays a table with the following columns: Department, Name, Shortcut Code, and Remarks. The 'Ophthalmology' row is highlighted in blue. Below the table are four buttons: 'New', 'Edit', 'Delete', and 'Cancel'.

Department	Name	Shortcut Code	Remarks
Internal Medicine	Nk		
Surgery	Wk		
Patient Type	Ophthalmology	OP	
Gender			
Area			
Bed No.			
Sample Type			

5.4.1.3 Editing Items/Shortcut Code

This section takes the editing of a department as an example to introduce the method for editing items and its shortcut code. The method for editing other new items is similar and is not introduced in details herein.

Steps for editing a department are shown as follows:

1. Select the department to be modified in the **Department** interface (for example the Internal Medicine), then click **Edit**.

A dialog box will pop up as shown in Figure 5-11.

Figure 5-11 Editing Item/Shortcut Code

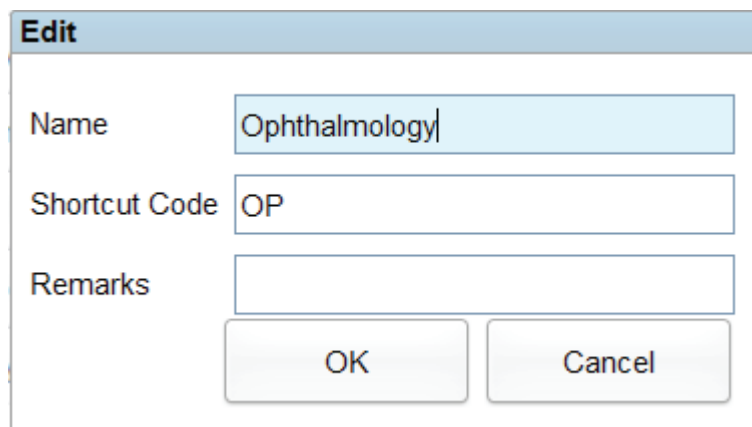

The image shows a dialog box titled "Edit". It contains three text input fields: "Name" with the text "Ophthalmology", "Shortcut Code" with the text "OP", and "Remarks" which is empty. At the bottom of the dialog are two buttons: "OK" and "Cancel".

2. Modify the **Name**, **Shortcut Code** and **Remarks** in each textbox according to the actual demand.

NOTE

- Newly added department name must be entered and it can not be the same as existing ones.
- The shortcut code is not necessary to be entered, but once set, every code must be unique.

3. Click **OK** to save the information.

5.4.1.4 Deleting a Shortcut Code

This section takes the deleting of a department as an example to introduce the method for deleting items and its shortcut code. The method for deleting other new items is similar and is not introduced in details herein.

Steps for deleting a department are shown as follows:

1. Select the department to be deleted in the **Department** interface, and then click **Delete**.

The interface pops up a dialog box as shown below.

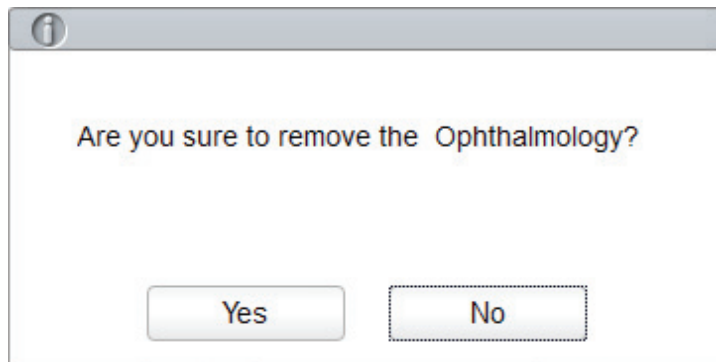
Figure 5-12 Deleting a Department

2. Click **Yes** to delete the department.

5.4.2 Parameter Unit

Some of the parameters of the analyzer can use different units which can be chosen as per user demand.

5.4.2.1 Accessing the Interface

Click **Parameter Unit** in the **Para.** selection to access the **Parameter Unit** setting interface. See Figure 5-13.

Figure 5-13 Setting Parameter Unit

Parameter Unit

Para.	Unit	Data Format
WBC	10 ³ /uL	*** **
Neu#	10 ³ /uL	*** **
Lym#	10 ³ /uL	*** **
Mon#	10 ³ /uL	*** **
Eos#	10 ³ /uL	*** **
Bas#	10 ³ /uL	*** **
ALY#	10 ³ /uL	*** **
LIC#	10 ³ /uL	*** **
Neu%	%	** *
Lym%	%	** *
Mon%	%	** *
Eos%	%	** *
Bas%	%	** *
ALY%	%	** *
LIC%	%	** *
RBC	10 ⁶ /uL	** **

Select unit system:
 USA ▼

Unit Options:
 10³/uL

Default

Apply

OK

Cancel

5.4.2.2 Selecting Unit System

Click the **Select unit system** dropdown list and select a unit system for the parameters among the 7 unit systems (**Custom**, **China**, **International**, **Britain**, **Canada**, **USA** and **Netherlands**). The default unit system is **USA**.

NOTE

- When selecting different unit standards, the corresponding unit list and unit option will be displayed differently.
- If another option is selected except the **Custom**, then the unit of each parameter can only be browsed.

5.4.2.3 Customizing Parameter Unit

1. Select **Custom** from the dropdown list of **Select unit system**.

Select unit system:



2. Click the parameter, of which the unit is to be set, from the parameter list (such as WBC).
3. Select a new parameter unit from the **Unit Options** list.

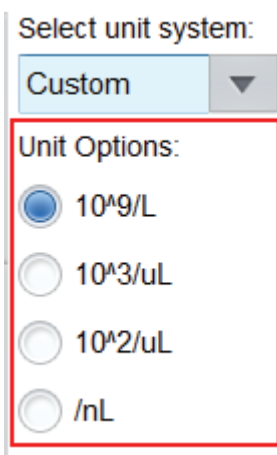

4. Click **Apply** or **OK** to save the configuration.

NOTE

- For parameters in the same group, if the unit of any parameter changes, the units of the other parameters change accordingly. (In the list, parameters will be sorted by group; the first parameter will be displayed in black and the other parameters in the same group will be displayed in grey.)
- If the parameters units change, the display format of the list data will change accordingly.

5.4.2.4 Retrieving Defaults

When setting the **Custom** unit system, if you click **Default**, the unit of the parameters can be restored to the initial default values.

5.4.3 Ref. Range

The reference range based on various normal groups can be set for the analyzer in the actual practice. If the analysis result of a sample is beyond the reference range, it will be regarded as clinically abnormal. The **Ref. Range** interface is where you view and set the high and low limits for your patients. The analyzer flags any parameter value above (↑) or below (↓) these limits.

This analyzer divides the patients into 5 demographic groups: General, Man, Woman, Child and Neonate. You can also customize other groups. The recommended limits are for reference only. To avoid misleading parameter flags, be sure to set the patient limits according to the characteristics of local population.

5.4.3.1 Accessing the Interface

Click **Ref. Group** in the **Para.** selection to access the reference group settings interface. See Figure 5-14.

Figure 5-14 Ref. Range

The screenshot shows the 'ref. Range' interface. It features a table with the following columns: Ref. Group, Default, Lower Limit of Age, Upper Limit of Age, and Gender. The 'General' group is selected and highlighted in blue. Below the table, there is a checkbox labeled 'Automatically match the customized reference group according to age and gender' which is checked. At the bottom, there are six buttons: Copy, New, Edit, Delete, Set as default, and Close.

Ref. Group	Default	Lower Limit of Age	Upper Limit of Age	Gender
General	√			
Man		13 Year	999 Year	Male
Woman		13 Year	999 Year	Female
Child		28 Day	13 Year	
Neonatus		0 Hour	28 Day	

Automatically match the customized reference group according to age and gender

Copy New Edit Delete Set as default Close

5.4.3.2 Copying a Ref. Group

Select a reference group and click **Copy**, and a new reference group with everything the same except the name of the reference group will be added to the system and a screen as shown in Figure 5-15 will pop up.

Figure 5-15 Copying a Ref. Group

Para.	Lower Limit	Upper Limit	Unit	Para.	Lower Limit	Upper Limit	Unit
WBC	3.50	9.50	10 ³ /uL	RBC	3.80	5.80	10 ⁶ /uL
Neu%	40.0	75.0	%	HGB	11.5	17.5	g/dL
Lym%	20.0	50.0	%	HCT	35.0	50.0	%
Mon%	3.0	10.0	%	MCV	82.0	100.0	fL
Eos%	0.4	8.0	%	MCH	27.0	34.0	pg
Bas%	0.0	1.0	%	MCHC	31.6	35.4	g/dL
Neu#	1.80	6.30	10 ³ /uL	RDW-CV	11.0	16.0	%
Lym#	1.10	3.20	10 ³ /uL	RDW-SD	35.0	56.0	fL
Mon#	0.10	0.60	10 ³ /uL	PLT	125	350	10 ³ /uL
Eos#	0.02	0.52	10 ³ /uL	MPV	6.5	12.0	fL
Bas#	0.00	0.06	10 ³ /uL	PDW	9.0	17.0	fL
ALY#	0.00	0.20	10 ³ /uL	PCT	0.108	0.282	%
ALY%	0.0	2.0	%				
LIC#	0.00	0.20	10 ³ /uL				
LIC%	0.0	2.5	%				

Ref. Group

Lower Limit of Age ▼

Upper Limit of Age ▼

Gender ▼

Save

Close

You can edit the new reference group. Save and close the screen, and then the copied reference group will be shown in the reference group list.

Ref. Group	Default	Lower Limit of Age	Upper Limit of Age	Gender
General	√			
Man		13 Year	999 Year	Male
Woman		13 Year	999 Year	Female
Child		28 Day	13 Year	
Neonatus		0 Hour	28 Day	
newgroup		0 Year	12 Year	Male

NOTE

The reference group name entered is not allowed to be empty nor the same as the existing ones.

5.4.3.3 Adding a New Ref. Group

If the built-in reference groups cannot meet the actual demand, you can add new ones and manually enter the information such as reference ranges for each parameter, names and genders. The procedures are shown as below:

1. Click **New**, and a screen for adding a new reference group will pop up. See Figure 5-16.

Figure 5-16 Adding a New Ref. Group

New							
Para.	Lower Limit	Upper Limit	Unit	Para.	Lower Limit	Upper Limit	Unit
WBC			10 ³ /uL	RBC			10 ⁶ /uL
Neu%			%	HGB			g/dL
Lym%			%	HCT			%
Mon%			%	MCV			fL
Eos%			%	MCH			pg
Bas%			%	MCHC			g/dL
Neu#			10 ³ /uL	RDW-CV			%
Lym#			10 ³ /uL	RDW-SD			fL
Mon#			10 ³ /uL	PLT			10 ³ /uL
Eos#			10 ³ /uL	MPV			fL
Bas#			10 ³ /uL	PDW			fL
ALY#			10 ³ /uL	PCT			%
ALY%			%				
LIC#			10 ³ /uL				
LIC%			%				

Ref. Group

Lower Limit of Age Year ▼

Upper Limit of Age Year ▼

Gender ▼

- Complete the entries for each parameter with reference to the parameter description in Table 5-2.

Table 5-2 Description of Ref. Group parameters

Parameter	Meanings	Operation
Ref. Group	Name of the new reference group.	Click the edit box and enter the information using the soft keyboard. English characters and numbers are allowed to be entered, while special characters are not. NOTE The reference group name entered is not allowed to be empty nor the same as the existing ones.
Lower Limit of Age	Lower limit of age of the reference group.	Enter an integer value in the textbox and select the age unit (year, month, week, day, or hour) from the drop list on the right. NOTE The Lower Limit of Age must be smaller than the Upper Limit of Age .
Upper Limit of Age	Upper limit of age of the reference group.	Enter an integer value in the textbox and select the age unit (year, month, week, day, or hour) from the drop list on the right. NOTE The Upper Limit of Age must be greater than the Lower Limit of Age .

Parameter	Meanings	Operation
Gender	Gender of the reference group.	Select Male , Female , Not defined from the dropdown list. The default setting is empty.
Lower Limit (of parameter)	Lower limit of parameters of the reference group. If the test result is lower than this value, it would be regarded as clinically abnormal.	Click the Lower Limit cell which corresponds to the parameter and enter a new value. NOTE The Lower Limit must be smaller than the Upper Limit .
Upper Limit (of parameter)	Upper limit of parameters of the reference group If the test result is higher than this value, it would be regarded as clinically abnormal.	Click the Upper Limit cell which corresponds to the parameter and enter a new value. NOTE The Upper Limit must be greater than the Lower Limit .

3. Click **Save** to save the settings.
4. Click **Close** to exit the interface.

5.4.3.4 Editing a Ref. Group

You can modify the reference range of the parameters according to actual needs and set suitable reference intervals (age range, gender, etc.).

The procedures are shown as below:

1. Select the reference group to be set, and click **Edit** to enter the interface as shown in Figure 5-17.

Figure 5-17 Editing a Ref. Group

Edit							
Para.	Lower Limit	Upper Limit	Unit	Para.	Lower Limit	Upper Limit	Unit
WBC	3.50	9.50	10 ³ /uL	RBC	3.80	5.80	10 ⁶ /uL
Neu%	40.0	75.0	%	HGB	11.5	17.5	g/dL
Lym%	20.0	50.0	%	HCT	35.0	50.0	%
Mon%	3.0	10.0	%	MCV	82.0	100.0	fL
Eos%	0.4	8.0	%	MCH	27.0	34.0	pg
Bas%	0.0	1.0	%	MCHC	31.6	35.4	g/dL
Neu#	1.80	6.30	10 ³ /uL	RDW-CV	11.0	16.0	%
Lym#	1.10	3.20	10 ³ /uL	RDW-SD	35.0	56.0	fL
Mon#	0.10	0.60	10 ³ /uL	PLT	125	350	10 ³ /uL
Eos#	0.02	0.52	10 ³ /uL	MPV	6.5	12.0	fL
Bas#	0.00	0.06	10 ³ /uL	PDW	9.0	17.0	fL
ALY#	0.00	0.20	10 ³ /uL	PCT	0.108	0.282	%
ALY%	0.0	2.0	%				
LIC#	0.00	0.20	10 ³ /uL				
LIC%	0.0	2.5	%				

Ref. Group

Lower Limit of Age ▼

Upper Limit of Age ▼

Gender ▼

2. Refer to Table 5-2 for the description of the parameters to finish the editing.

NOTE

- For the built-in reference group, you can modify the upper limit and lower limit of the parameters, but not its name, the upper limit and lower limit of age as well as gender.
- Click **Default** to restore the setting of the selected reference group to the default value.
- Non-built-in reference group (which is added by user) cannot restore defaults.

3. Click **Save** to save the modification.
4. Click **Close** to exit.

5.4.3.5 Deleting a Ref. Group

Click **Delete**, and select **Yes** in the pop-up dialog box to delete the selected customized reference group.

NOTE

Built-in reference group can not be deleted.

5.4.3.6 Setting Default Ref. Group

When you pre-enter patient information in the **Sample Analysis** interface, the **Ref. Group** displayed by default is the default reference group.

The default setting is **General**. You can change it as required. Select a reference group and click **Set as default** to set the selected reference group as the default reference group.

As shown in Figure 5-18, the reference group with a check mark in its **Default** column is a default reference group.

Figure 5-18 Setting Default Ref. Group

Ref. Group	Default	Lower Limit of Age	Upper Limit of Age	Gender
General				
Man		13 Year	999 Year	Male
Woman		13 Year	999 Year	Female
Child		28 Day	13 Year	
Neonatus		0 Hour	28 Day	
newgroup	✓	0 Year	12 Year	Male

Automatically match the customized reference group according to age and gender

Copy New Edit Delete Set as default Close

5.4.3.7 Automatically Match the Customized Reference Group According to Age and Gender

If **Automatically match the customized reference group according to age and gender** is checked, the customized reference group will be automatically assigned patients by the system according to their age and gender when the patient information is entered. If it fails to find a matching customized reference group for a patient, the patient will be assigned to the built-in reference group. When the system automatically matches the reference group according to age and gender, the rules listed in Table 5-3 shall be followed.

Table 5-3 Rules for Matching the Reference Group

Automatically match the customized reference group according to age and gender	Customized Ref. Group	Match the reference group
Unchecked	N/A	Built-in reference group
Checked	None	Built-in reference group
Checked	Created	Preferentially match the customized reference group

NOTE

When the customized ref. groups are used to match the reference group, the matching will be performed from top down according to the customized ref. groups displayed in the screen.

5.4.4 Microscopic Exam. Settings

You can perform the microscopic exam. settings, including adding, editing, deleting and adjusting the list order as per the actual demand.

NOTE

The operations of adding, editing, deleting and adjusting the list order do not affect the sample record in which the microscopic examination results have been entered and saved. Such operations are only valid for the record in which the microscopic examination results have not been saved, and the samples analyzed after the setting operations.

5.4.4.1 Accessing the Interface

Click **Microscopic Exam.** in the **Para.** selection to access the microscopic examination setting interface. See Figure 5-19.

Figure 5-19 Microscopic Exam. Settings

No.	Parameter Name	Code System
1	Neutrophilic segmented granulocyte	
2	Neutrophilic band granulocyte	
3	Lymphocyte	
4	Monocyte	
5	Eosinophil	
6	Basophil	
7	Plasmacyte	
8	Atypical Lymph	
9	Blast	
10	Promyelocyte	

5.4.4.2 Adding a New Microscopic Exam. Parameter

Do as follows to add a new microscopic examination parameter.

1. Click **New** in the **Microscopic Exam. Settings** interface.

A dialog box will pop up as shown in Figure 5-20.

Figure 5-20 Adding a New Microscopic Exam. Parameter

New

Parameter Name

Code System

Note: coding system is the code ID in LIS transmission. You may not input the value if it is not needed.

2. Input the parameter name and its coding system in the corresponding textboxes.
 - The **Parameter Name** can not be empty and up to 32 characters can be entered.
 - The **Code System** is the code ID of the parameter. It is used for LIS transmission only when the parameter is transmitted to the LIS. You may not input the value if it is not needed. Up to 20 characters can be entered.
3. Click **OK**.

The name of the new parameter will be displayed in the microscopic exam. parameter list.

5.4.4.3 Editing a Microscopic Exam. Parameter

Select a parameter name from the list and click **Edit** to modify it. See Figure 5-21.

Figure 5-21 Editing a Microscopic Exam. Parameter

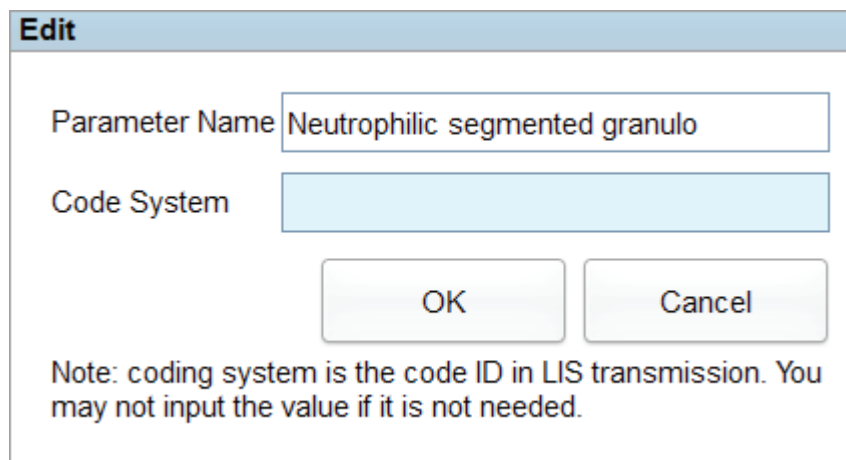

The screenshot shows a dialog box titled "Edit". It contains two input fields: "Parameter Name" with the text "Neutrophilic segmented granulo" and "Code System" which is currently empty. Below the fields are two buttons: "OK" and "Cancel". At the bottom of the dialog, there is a note: "Note: coding system is the code ID in LIS transmission. You may not input the value if it is not needed."

5.4.4.4 Deleting a Microscopic Exam. Parameter

Select a parameter name from the list, click the **Delete** button and then click **Yes** in the popup dialog box to delete this parameter.

Figure 5-22 Deleting a Microscopic Exam. Parameter

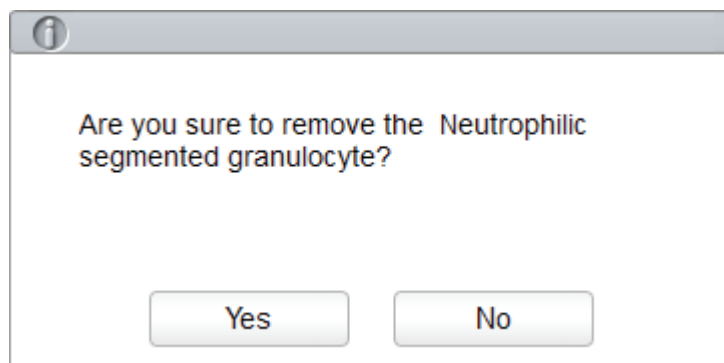

The screenshot shows a confirmation dialog box with an information icon in the top-left corner. The text inside the dialog asks: "Are you sure to remove the Neutrophilic segmented granulocyte?". At the bottom, there are two buttons: "Yes" and "No".

5.4.5 Research Use Only (RUO) Parameters

Click **RUO Parameters** in the **Setup > Parameter** interface to enter the **RUO Parameters** setting interface. See Figure 5-23.

Figure 5-23 Setting RUO Parameters

The RUOs include ALY%, LIC%, NRBC%, ALY#, LIC# and NRBC#.

NOTE

- The RUO parameters are for research use only, not for diagnostic use.
 - The NRBC# and NRBC% are parameters for DF52, DF55 and DF56 only.
-
- Display RUO Parameters
 - It's checked by default, which means the information regarding the RUO parameters will be displayed in the counting results. If it's unchecked, the RUO parameters, the * mark and the declaration will not be displayed in the counting results.
 - Display "*" mark
 - It's checked by default, which means the "*" mark will be displayed in the counting results; If it's unchecked, the "*" mark and the declaration will not be displayed.
 - Display declaration
 - It's checked by default, which means the declaration will be displayed in the counting results; if it's unchecked, the declaration will not be displayed.
 - Print RUO parameters
 - It's checked by default, which means the RUO parameters will be printed in the report. If it's unchecked, the RUO parameters, the "*" mark and the declaration will not be printed in the report.
 - Print "*" mark
 - It's checked by default, which means the "*" mark will be printed in the report. If it's unchecked, the "*" mark and the declaration will not be printed in the report.
 - Print declaration
 - It's checked by default, which means the declaration will be printed in the report. If it's unchecked, the declaration will not be printed in the report.
 - Editing Declaration

The default declaration is: "*" means "research use only, not for diagnostic use". You can modify the declaration in the textbox as per the actual demand. Up to 50 characters can be entered, including all characters, numbers, letters and other special characters (except "/" and "\") on the keyboard.

NOTE

Any change made to the display settings or printing of the RUO parameters, the "*" mark and the declaration will be applied to all the RUO parameters (before and after the change).

5.4.6 Customized Parameters

Except for this analyzer's analysis parameters, parameters collected from other testing instruments or via manual testing by the user are customized parameters. You can set customized parameters so they can be printed together with this analyzer's analysis parameter details on the Hematology Analysis Report.

This analyzer's default customized parameters include: **Blood Type**, **RH Blood Group**, **ESR**, **C-reactive Protein** and **Reticulocyte**. You can set the unit and reference range of default customized parameters as well as add and set customized parameters.

5.4.6.1 Accessing the Interface

Click **Custom Para.** in the **Para.** selection.

The customized parameters setting interface as shown in Figure 5-24 will pop up on the screen.

Figure 5-24 Customized Parameter Settings

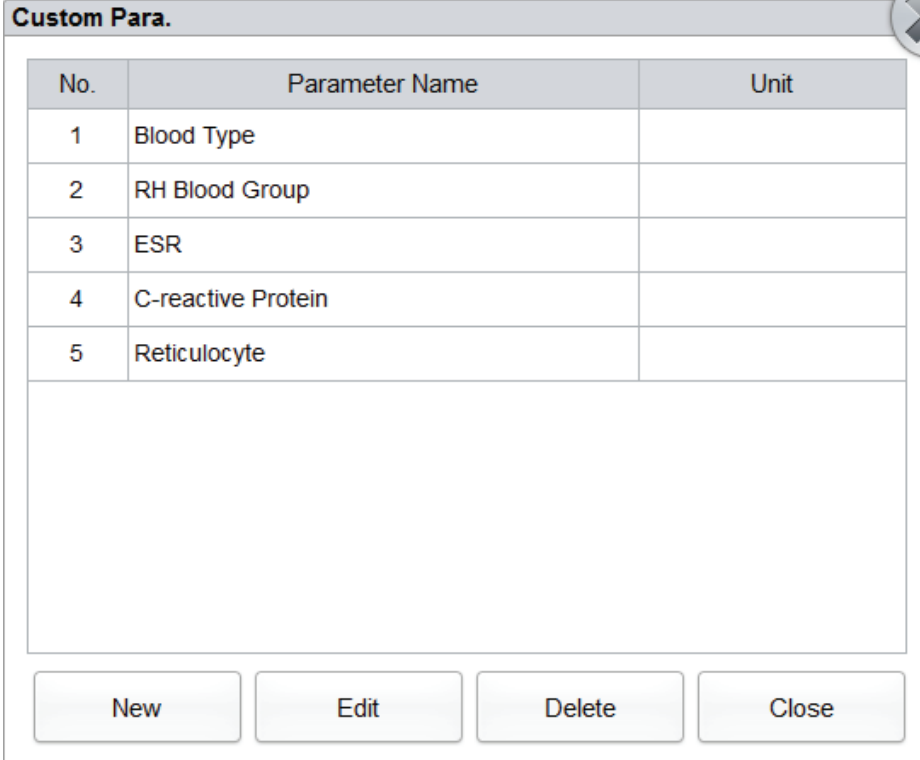

The screenshot shows a window titled "Custom Para." with a table containing five rows of parameters. Below the table are four buttons: "New", "Edit", "Delete", and "Close".

No.	Parameter Name	Unit
1	Blood Type	
2	RH Blood Group	
3	ESR	
4	C-reactive Protein	
5	Reticulocyte	

Buttons: New, Edit, Delete, Close

5.4.6.2 Adding a Customized Parameter

1. Click **New**. The interface as shown in Figure 5-25 will pop up on the screen.

Figure 5-25 Adding a Customized Parameter

Ref. Group	Lower Limit	Upper Limit	Parameter Name
General			<input type="text"/>
Man			Unit
Woman			<input type="text"/>
Child			

2. Click the textboxes of **Parameter Name** and **Unit** respectively, and enter the name and unit of the customized parameter.
3. Click corresponding cells of the **Upper Limit** and **Lower Limit** of the reference group, and input values.

You can also customize the reference group according to the actual situation. For details, see **5.4.3 Ref. Range**.

4. Click **OK**.

The added parameter will be displayed in the customized parameter list.

5.4.6.3 Editing a Customized Parameter

You can set the unit and reference range of customized parameters. Detailed steps are shown below:

1. Select the customized parameter to be edited, and click **Edit**.

The interface as shown in Figure 5-26 will pop up on the screen.

Figure 5-26 Editing a Customized Parameter

Ref. Group	Lower Limit	Upper Limit	Parameter Name
General			Reticulocyte
Man			Unit
Woman			
Child			
			Apply
			OK
			Cancel

2. Click the textboxes of **Parameter Name** and **Unit** respectively, and modify the name and unit of the customized parameter.
3. Click corresponding cells of the **Upper Limit** and **Lower Limit** of the reference group, and modify the values.

You can also customize the reference group according to the actual situation. For details, see **5.4.3 Ref. Range**.

4. Click **OK**.

5.4.6.4 Deleting a Customized Parameter

Select a customized parameter, and click on **Delete**. Then, the parameter and its corresponding reference group will be deleted.

5.5 Meterage Settings

5.5.1 Gain Settings

You can adjust each digital pot at the **Gain Settings** interface. It is not recommended to adjust gains frequently.

Click **Gain Settings** in the **Meterage** selection to access the gain setting interface. See Figure 5-27.

Figure 5-27 Gain Settings

Item	Current Value	Adjustment Rate	
WBC	120	100	%
RBC	84	100	%
DIFF-LS	35	100	%
DIFF-HS	95	100	%
DIFF-MS	56	100	%
BASO-LS	0	100	%
BASO-HS	0	100	%
BASO-MS	0	100	%

HGB Current Value:

HGB Blank Voltage: 0.00

Apply OK Cancel

NOTE

New value of the gain adjustment = **Current Value** × **Adjustment Rate**.

- Setting the WBC gain
 The WBC gain here is in whole blood mode.
 Setting method I: click the **Current Value** of the WBC and enter the new value.
 Setting method II: click the **Adjustment Rate** cell of the WBC and enter the adjustment rate of the new value relative to the current value.
- Setting the WBC gain
 RBC channel gain.
 Setting method I: click the **Current Value** of the RBC and enter the new value.
 Setting method II: click the **Adjustment Rate** cell of the RBC and enter the adjustment rate of the new value relative to the current value.
- DIFF-LS, DIFF-HS, DIFF-MS
 DIFF channel gain.
 Setting method I: click the **Current Value** of the parameter and enter the new value.
 Setting method II: click the **Adjustment Rate** cell of the parameter and enter the adjustment rate of the new value relative to the current value.
- BASO-LS, BASO-HS, BASO-MS
 BASO channel gain.
 Setting method I: click the **Current Value** of the parameter and enter the new value.

Setting method II: click the **Adjustment Rate** cell of the parameter and enter the adjustment rate of the new value relative to the current value.

- Setting the HGB gain

Current digital circuit gain. The purpose for adjusting the HGB channel gain is to change the HGB background voltage.

You can enter the value directly in the **HGB Current Value** textbox or click the adjusting button to adjust the HGB gain.

- Setting the HGB Blank Voltage

The background voltage derived from HGB gain cannot be modified. HGB Background Voltage can be adjusted within the specified range (4.2V~4.8V) by modifying **HGB Current Value**.

5.5.2 Flag

When the test result meets the requirement of the flag rules, the corresponding flag will be displayed on the screen. You can edit the flag rules as per the actual demand and relevant lab procedures.

Accessing the Interface

Click **Flag** in the **Meterage** selection to access the flag rules setting interface. See Figure 5-28.

Figure 5-28 Flag

Flag	Flag Rules
Leucopenia	WBC < 2.50 (10 ³ /uL)
Leucocytosis	WBC > 18.00 (10 ³ /uL)
Neutropenia	NEU# < 1.00 (10 ³ /uL)
Neutrophilia	NEU# > 11.00 (10 ³ /uL)
Lymphopenia	LYM# < 0.80 (10 ³ /uL)
Lymphocytosis	LYM# > 4.00 (10 ³ /uL)
Monocytosis	MON# > 1.50 (10 ³ /uL)
Eosinophilia	EOS# > 0.70 (10 ³ /uL)
Basophilia	BAS# > 0.20 (10 ³ /uL)
Erythrocytosis	RBC > 6.50 (10 ⁶ /uL)
Anisocytosis	RDW-CV > 22.0 (%) and RDW-SD > 64.0 (fL)
Macrocytosis	MCV > 113.0 (fL)
Microcytosis	MCV < 70.0 (fL)
Anemia	HGB < 9.0 (g/dL)
Hypochromia	MCHC < 29.0 (g/dL)
Thrombocytosis	PLT > 600 (10 ³ /uL)
Thrombopenia	PLT < 60 (10 ³ /uL)

Setting Flag Rules

You can select the name of the **Flag** in the **Flag** interface, then click **Edit** to modify the rules in the popup dialog box. See Figure 5-29.

Figure 5-29 Setting Flag Rules

Edit

Leucopenia

WBC < 10³/uL

Restoring Defaults

Click **Set as default** to restore the parameter to the default value.

5.6 Communication Settings

5.6.1 Host Network Settings

On the host communication screen, you can set the network information of the analyzer to enable its network connection.

Click **Host Communication** in the **Communicate** selection to access the host network setting interface. See Figure 5-30.

Figure 5-30 Host Network Settings

Host Communication

You can get IP settings assigned automatically if your network supports this capability. Otherwise, you need to ask your network administrator for the appropriate IP settings.

Obtain an IP address automatically

Use the following address:

IP Address

Subnet mask

Default gateway

Obtain DNS server address automatically

Use the following DNS server addresses:

Preferred DNS server

Alternate DNS server

Refer to Table 5-4 for the description of relevant parameters.

Table 5-4 Description of Host Communication Setting Parameters

Parameter	It means	Operation
Obtain an IP address automatically	The host gets the IP address dynamically from a DHCP server or a PPP dial-up network access server. This option is not applicable for the dial-up connection of SLIP server.	Please choose according to the actual situation.
Use the following address:	Specify the host to use the manually set IP address. If this option is selected, you need to set: <ul style="list-style-type: none"> ● IP address The IP address obtained from the network administrator or Internet service provider. ● Subnet mask The subnet mask obtained from the network administrator or Internet service provider. ● Default gateway The IP address of the default gateway; the router's IP address for connecting the independent IP network segment. 	Obtain the IP address, subnet mask and default gateway of the host from the network administrator or Internet service provider.
Obtain DNS server address automatically	Automatically obtain the IP address of the Domain Name Server (DNS).	Please choose according to the actual situation.
Use the following DNS server addresses:	Specify the IP address of the DNS server of the host. <ul style="list-style-type: none"> ● Preferred DNS server The IP address of preferred or primary DNS servers. ● Alternate DNS server (Optional) The IP address of alternative or secondary DNS servers of the host. This server will be used if the specified IP address of the Preferred DNS server is not available or if the DNS name cannot be resolved as the IP address of the DNS server which the host has inquired. 	Obtain the IP address of DNS server from the network administrator or Internet service provider.

NOTE

You can click **Details** to check the network information of the analyzer, including physical address, IP address, subnet mask, default gateway, DNS server, etc.

5.6.2 LIS Communication

In the LIS Communication interface, You can set the communication between the system and the LIS,

including network settings, protocol settings and transmission mode.

Click **LIS Communication** in the **Communication** selection to access the Laboratory Information System (LIS) communication setting interface. See Figure 5-31.

Figure 5-31 Setting LIS Communication

The screenshot shows the 'LIS Communication' configuration window. It is organized into several sections:

- Network Settings:** Includes an IP Address field, a Port field set to 5600, and a 'Reconnect' button.
- Transmission Settings:** Contains checkboxes for 'Auto-communication', 'Bidirectional LIS/HIS Communication', 'Transmit after result modified', and 'Enable Heartbeat Test'. It also features a 'Bidirectional LIS/HIS Communication Timeout' set to 10 seconds and a 'Matched by' dropdown menu set to 'Sample ID'.
- Protocol Settings:** Includes a checkbox for 'Communication Acknowledgement' and an 'ACK timeout' set to 10 seconds.
- Graph Format:** A dropdown menu set to 'PNG'.
- Histogram Transmission Method:** A dropdown menu set to 'Not transmit'.
- Scattergram Transmission Method:** A dropdown menu set to 'Not transmit'.
- DIFF Scattergram:** Checkboxes for 'LS-MS', 'LS-HS', and 'HS-MS'.
- BASO Scattergram:** A checkbox for 'LS-MS'.

At the bottom of the window are three buttons: 'Apply', 'OK', and 'Cancel'.

Refer to Table 5-5 for the description of relevant parameters.

Table 5-5 Description of LIS Communication Setting Parameters

Parameter		It means	Operation
Network Settings	IP address	The IP Address of the LIS.	Please set it according to the actual situation.
	Port	The port of the LIS. The default value is 5600.	Please set it according to the actual situation. An integer between 1025 and 65535 can be entered. NOTE If the analyzer is disconnected with the LIS , click the Reconnect button to connect the LIS again.

Parameter		It means	Operation
Transmission Settings	Auto-communication	<p>Whether to upload the sample results automatically.</p> <ul style="list-style-type: none"> • If checked, the system will automatically upload the result to the LIS upon the completion of the analysis. • If unchecked, the result of analysis will not be automatically uploaded. <p>NOTE</p> <p>If the Bidirectional LIS/HIS Communication is checked, this parameter will be checked automatically.</p>	Please choose according to the actual situation.
	Bidirectional LIS/HIS Communication	<p>Whether to enable the bidirectional communication between the software and the LIS/HIS.</p> <ul style="list-style-type: none"> • If checked, the system will automatically obtain the sample/patient information from LIS/HIS after the sample analysis is started or the patient information is edited, and automatically upload the result to the LIS upon the completion of the analysis. <p>NOTE</p> <p>If the information is matched by sample ID, you only need to enter the sample ID; if the information is matched by Med Rec.No., you only need to enter the medical record number.</p> <ul style="list-style-type: none"> • If unchecked, the software system will not obtain the sample/patient information, and decide whether to upload result based on the setting of the Auto-communication parameter. 	Please choose according to the actual situation.
	Bidirectional LIS/HIS Communication Timeout	<p>Timeout duration of the bidirectional LIS/HIS communication.</p> <p>The default value is 10 seconds, that is, the communication will be stopped if the software system does not connect with the LIS/HIS successfully within 10 seconds.</p> <p>NOTE</p> <p>The parameter is valid only when the Bidirectional LIS/HIS Communication is checked.</p>	<p>Directly enter in the textbox.</p> <p>Input range: an integer between 1 and 120.</p> <p>Unit: second.</p>

Parameter		It means	Operation
	Matched by	<p>The matching method of the analyzer with the LIS/HIS sample information.</p> <ul style="list-style-type: none"> • Sample ID The sample information of LIS/HIS is matched by the sample ID when running samples. • Med Rec. No. The sample information of LIS/HIS is matched by the Med Rec.No. when running samples. If the Med Rec.No. is empty, the sample information will not be matched. <p>NOTE The parameter is only valid when the Bidirectional LIS/HIS Communication is checked.</p>	Please choose according to the actual situation.
	Transmit after result modified	<p>Whether to upload the sample results automatically after the sample results is edited.</p> <ul style="list-style-type: none"> • If checked, the sample results will be uploaded automatically after the sample results is edited. • If unchecked, the system will not execute any operations. 	Please choose according to the actual situation.
	Enable Heartbeat Test	<p>Whether to enable heartbeat detection.</p> <p>It's unchecked by default. If this is checked, the connection status between the analyzer and the LIS system will be detected regularly. During the communication between the analyzer and the LIS system, if the LIS server is disconnected, the LIS status icon turns gray; when the LIS server returns to normal, the analyzer will automatically reconnect with the LIS system to resume communication.</p> <p>NOTE The parameter is only valid when the Auto-communication is checked.</p>	Please choose according to the actual situation.

Parameter		It means	Operation
Protocol Settings	Communication Acknowledgement	<p>Whether to enable communication acknowledgement.</p> <ul style="list-style-type: none"> • If checked, the communication between the system and the LIS is successful when the ACK response from the LIS is received within the duration of ACK timeout; no response received indicates communication failure. • If unchecked, the communication between the system and the LIS shall be considered successful no matter the ACK response from the LIS is received or not. <p>NOTE</p> <p>The system will send the next message continuously no matter the communication is successful or not.</p>	Please choose according to the actual situation.
	ACK timeout	<p>Timeout duration of the ACK response.</p> <p>The default value is 10 seconds, that is, the communication will be considered failed if the system receives no ACK response within 10 seconds.</p> <p>NOTE</p> <p>The parameter is valid only when the Communication Acknowledgement is checked.</p>	<p>Click ↑ or ↓ or directly enter in the textbox.</p> <p>An integer between 1 and 120 can be entered.</p> <p>Unit: Second (sec.)</p>
Graph Format		Graph transmission format, including PNG and BMP.	Please choose according to the actual situation.
Histogram Transmission Method		<p>The methods for transmitting the histogram to the LIS when the result is transmitted by the system, including:</p> <ul style="list-style-type: none"> • Not transmit Do not transmit the histogram to the LIS. • Bitmap Transmit the histogram to the LIS in the format of screen display. • Transmitting bitmap for printing The histogram is transmitted by the system to the LIS in the format of a printed report. 	Please choose according to the actual situation.

Parameter	It means	Operation
Scattergram Transmission Method	<p>The methods for transmitting the scattergram to the LIS when the result is transmitted by the system, including:</p> <ul style="list-style-type: none"> • Not transmit Do not transmit the scattergram to the LIS. • Bitmap Transmit the scattergram to the LIS in the format of screen display. • Transmitting bitmap for printing The scattergram is transmitted by the system to the LIS in the format of a printed report. 	Please choose according to the actual situation.
DIFF Scattergram	<p>The DIFF scattergrams transmitted to the LIS, including LS-MS, LS-HS and HS-MS.</p> <p>NOTE The parameter is invalid when Not transmit is set as the scattergram transmission method.</p>	Please choose according to the actual situation.
BASO Scattergram	<p>The BASO scattergram transmitted to the LIS, namely LS-MS.</p> <p>NOTE The parameter is invalid when Not transmit is set as the scattergram transmission method.</p>	Please choose according to the actual situation.

5.7 User management

After logging in the system, the administrator has the access to set the account information of general users and other administrators; common users can only browse the user list and change their own passwords.

5.7.1 Accessing the Interface

Click **User** in the **Setup** interface to access the user management interface as shown in Figure 5-32.

Figure 5-32 User management

User Name	Name	User Group	Default User	Remarks
admin	admin	Administrator		

5.7.2 Creating a User

Click **New** to set the account information of a new user in the popup interface, including username, first and last name, password, user group and remarks, etc. See Figure 5-33.

Figure 5-33 Creating a user

User Name	<input type="text"/>	(Login Account)
Name	<input type="text"/>	
Password	<input type="text"/>	
Confirm Password	<input type="text"/>	
User Group	Common User	▼
Remarks	<input type="text"/>	

NOTE

User Group includes **Common User** and **Administrator**. Users are assigned different access levels according to the user group they belong to.

Click **OK** after the setting is complete. The information of the new user will be shown in the user list.

5.7.3 Editing a User

Select the user to be edited and click **Edit** to modify the name and user group.

Figure 5-34 Editing a User

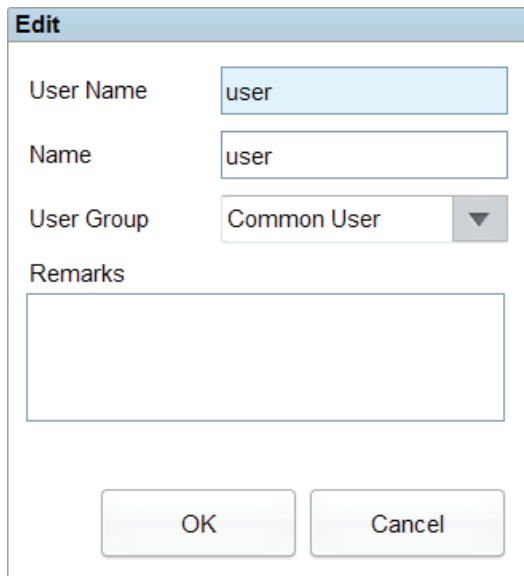

The screenshot shows a dialog box titled "Edit". It contains the following fields and controls:

- User Name:** A text input field containing the text "user".
- Name:** A text input field containing the text "user".
- User Group:** A dropdown menu with "Common User" selected.
- Remarks:** A large empty text area.
- Buttons:** "OK" and "Cancel" buttons at the bottom.

5.7.4 Deleting a User

Select the user to be deleted and click **Delete**, and then select **OK** in the pop-up dialog box to delete the user.

NOTE

The administrator cannot delete his/her own information.

5.7.5 Setting the Default User

Select a user and click **Set as default user** to set this user as the default user.

After the setting is completed, the following message box will pop up.

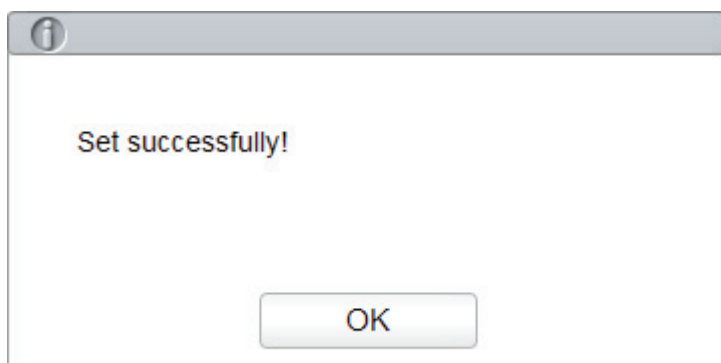

After it is set successfully, the default user name will be displayed in the login box next time and you only needs to enter the corresponding password. See Figure 5-35.

Figure 5-35 Login after Setting the Default User

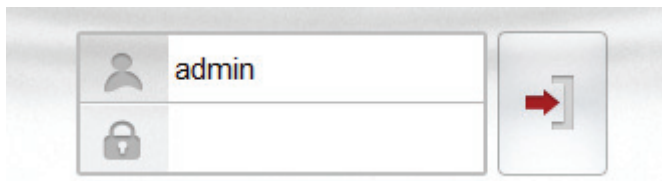

5.7.6 Changing Password

Click **Change Password**, enter the old password and new password of the user and confirm the new password in the popup dialog box, then click **OK**.

Figure 5-36 Changing Password

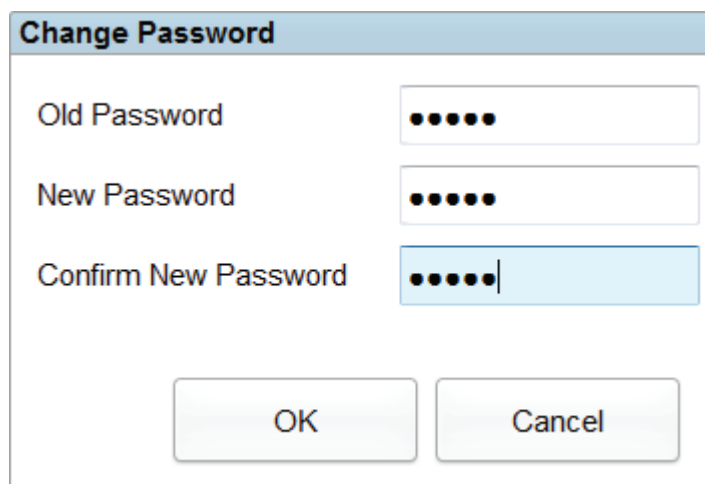

NOTE

You can only change his/her own password and cannot change the password of other users.

5.7.7 Resetting Password

If the user forgets the password or the password is required to be reset due to other reasons, please click **Reset Password** to reset the password of the selected user to the initial password. The reset password is the same as the user name.

Figure 5-37 shows that the password is successfully reset.

Figure 5-37 Resetting Password

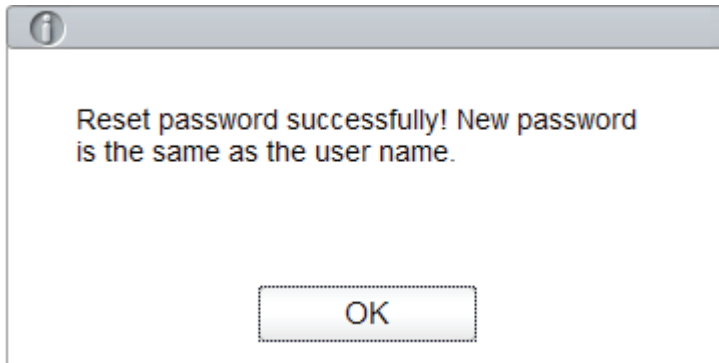
**NOTE**

The administrator is allowed to reset the password of all administrators and general users; general users do not have the access to reset the password.

5.8 Print Settings

Click **Print Settings** in the **Setup** interface for relevant print settings, including the default printer, template, report, copies and margins, etc.

Figure 5-38 Print Settings

 The 'Print Settings' dialog box is divided into several sections:

- Printer:** Includes dropdowns for 'Printer driver' (set to 'Check automatically'), 'Printer' (set to 'Adobe PDF'), and 'Printer Resolution' (set to 'High Resolution').
- Report Settings:** Includes a text field for 'Report Title' (set to 'Hematology Analysis Report') and a numeric spinner for 'Copies' (set to '1').
- Format Settings:** Includes dropdowns for 'Report Type' (set to 'Report'), 'Paper Type' (set to 'A4'), and 'Template' (set to 'A4-Portrait-Parameters-Cel'). It also shows 'Paper size' as '210*297 mm' and buttons for 'Refresh', 'Import', 'Delete', and 'Export'.
- Auto Settings:** Features a radio button for 'Autoprint' (set to 'Off') and three checkboxes: 'Auto print after validation', 'Auto validate when printing', and 'Print after validation' (all unchecked).
- Printing Options:** A list of checkboxes: 'Print Flag' (checked), 'Print Ref. Range' (checked), 'Print Suspicious Flag' (unchecked), 'Print Ref. Range Flags' (checked), 'Print Microscopic Exam Para.' (checked), 'Print result edited flags' (unchecked), 'Two reports in one page (half of A4)' (unchecked), 'Update blank test time before be printed' (unchecked), and 'Print as black and white(Report)' (unchecked). Below this list are buttons for 'QC Graph Settings' and 'Printer Box Settings'.

 At the bottom of the dialog are three buttons: 'Apply', 'OK', and 'Cancel'.

Printer Settings

You can set the printer and driver of the system in the **Printer** selection. See Figure 5-39.

Figure 5-39 Printer Settings

Printer

Printer driver	Check automatically	▼
Printer	Adobe PDF	▼
Printer Resolution	High Resolution	▼

- **Printer Driver**
The system automatically detects the printer driver by default.
- **Printer**
Select a printer to be used from the dropdown list. If the dropdown list is blank, it indicates that no printer has been installed for the operating system. In this case, install a printer, and then perform the relevant settings and printing operations.
- **Printer Resolution**
Select a proper resolution from the dropdown list. The higher the resolution of the printer, the better the print quality.

Report Settings

You can set relevant parameters of the report in the **Report Settings** combo box. See Figure 5-40.

Figure 5-40 Report Print Setting

Report Settings

Report Title	Hematology Analysis Report
Copies	<input type="button" value="-"/> <input type="text" value="1"/> <input type="button" value="+"/>

- **Report Title**
Enter the title of the report in the **Report Title** textbox. The default setting is **Hematology Analysis Report**.
- **Copies**
You can enter the number of copies to be printed for a report in the **Copies** textbox according to the actual demand. Click to increase the number of copies and click to decrease the number of copies or enter the number of copies in the edit box directly. Range of the copies is between 1 and 100 and the default value is 1.

Format Settings

Report type and template of prints can be set in the Format Settings combo box. See Figure 5-41.

Figure 5-41 Format Settings

Format Settings

Report Type	Report	▼
Paper Type	A4	▼
Template	A4-Portrait-Parameters-Cel	▼
Paper size	210*297 mm	
<input type="button" value="Refresh"/> <input type="button" value="Import"/> <input type="button" value="Export"/>		
<input type="button" value="Delete"/>		

- **Selecting Report Type**
Select the format type to be set from the dropdown list of the **Report Type**. The default setting is **Report**.
- **Selecting Paper Type**
Select the paper type (size) from the dropdown list of the **Paper Type**, such as **A4**. After the selection is completed, the corresponding paper size will be shown at the bottom of the list, such as **210*297 mm**.
- **Selecting Template**
Select the template to be set from the dropdown list of the **Template**.
- **Refresh**
Click **Refresh** to refresh the format list after the customization by the administrator.
- **Importing/Exporting template**
You can export the existing template to a USB flash disk, and edit the template. After editing, import the template to the system to complete the customization of the template.

NOTE

Before importing/exporting template, insert a USB flash disk in the USB interface on the analyzer.

- **Exporting template**
Select the template to be exported from the dropdown list of **Template** and click **Export**.
Select the export path in the popup dialog box, and click **Save**.
- **Importing template**
Click **Import** and select the required template in the pop-up dialog box, then click **Open**.
- **Deleting template**
Select the template to be deleted from the dropdown list of the **Template**.

NOTE

Only customized templates can be deleted, the built-in templates can not be deleted.

Auto Settings

- Autoprint

The default setting is **Off**, which means the report should be printed manually after the results are obtained.

If it is set to **On**, the system will automatically print the report of the sample as per the current report template once the counting results are obtained.

NOTE

- If Print after validation is checked, the autoprint function becomes invalid.
- Auto print is not applicable for the background results.

- Auto print after validation

It's unchecked by default, which means the system can print the report automatically without validation.

If it's checked, the report will be printed automatically after it's been validated instead of being printed right after the results are obtained each time.

NOTE

The parameter is valid only when the **Autoprint** is set to **On**.

- Auto validate when printing

It's unchecked by default, which means the report will not be automatically validated by the system at the time of printing.

If it's checked, the report will be automatically validated and printed by the system at the time of printing.

- Print after validation

It's unchecked by default, which means the report can be printed without validation.

If it's checked, the report can be printed only after validation and autoprint is unexecutable.

Printing Options

- Print Flag

It's checked by default, which means the flag information will be printed in the report. If it's not checked, it will not be printed.

- Print Ref. Range

It's checked by default, which means the reference range of the parameter will be shown in the printed report; if it's unchecked, the results alone, rather than reference range, will be shown in the printed report and the reference range will not.

- Print Suspicious Flag

It's unchecked by default, which means the suspicious flag “?” will not be shown in the printed report; if it's checked, such flag can be shown.

- Print Ref. Range Flags

It's checked by default, which means the printed report can show the ref. range flag (↑ or ↓); if it's unchecked, such a flag will not be shown.

- Print Microscopic Exam Para

It's checked by default, which means the result of **Microscopic Exam. Parameters** will be printed in the report. If it's not checked, it will not be printed.

- Print result edited flags

It's unchecked by default, which means the mark for the edited results will not be shown in the printed report.

If checked, the mark (**M** or **m**) for the edited results will be shown in the printed report if the parameters have been modified.

- Two reports in one page (half of A4)

It's unchecked by default. If this is checked, the default template size in Format Settings is half an A4 page (e.g., A4_Half-Portrait-Parameters), so two reports can be printed in one piece of A4 paper.

NOTE

When **Autoprint** is **On**, a page remains to be printed with one report.

- Update blank test time before be printed

It's unchecked by default, which means the blank test time will not be processed by the system.

If it's checked, the **Delivery Time** will be automatically updated as the **Run Time** by the system at the time of printing.

- Print as black and white (Report)
-

NOTE

The parameter is valid only when the **Report Type** is set to **Report**.

It's unchecked by default, which means the report will be printed according to the default settings of the printer.

If it's checked, the report will be printed as black and white.

- QC Graph Settings

You choose the QC graph parameters to be printed as required.

As shown in Figure 5-42, the system prints all the parameter results by default. You can uncheck the parameters you don't want to print.

Figure 5-42 QC Graph Settings

QC Graph Settings

<input checked="" type="checkbox"/> WBC	<input checked="" type="checkbox"/> Bas#	<input checked="" type="checkbox"/> MPV
<input checked="" type="checkbox"/> Neu%	<input checked="" type="checkbox"/> RBC	<input checked="" type="checkbox"/> PDW
<input checked="" type="checkbox"/> Lym%	<input checked="" type="checkbox"/> HGB	<input checked="" type="checkbox"/> PCT
<input checked="" type="checkbox"/> Mon%	<input checked="" type="checkbox"/> HCT	
<input checked="" type="checkbox"/> Eos%	<input checked="" type="checkbox"/> MCV	
<input checked="" type="checkbox"/> Bas%	<input checked="" type="checkbox"/> MCH	
<input checked="" type="checkbox"/> Neu#	<input checked="" type="checkbox"/> MCHC	
<input checked="" type="checkbox"/> Lym#	<input checked="" type="checkbox"/> RDW-CV	
<input checked="" type="checkbox"/> Mon#	<input checked="" type="checkbox"/> RDW-SD	
<input checked="" type="checkbox"/> Eos#	<input checked="" type="checkbox"/> PLT	

Apply OK Cancel

- Printer Box Settings

Figure 5-43 Printer Box Settings

Printer Box Settings

IP Address

Port

Apply OK Cancel

- IP address

The default value is 10.0.0.200. It supports manual input and selecting from the drop-down list.

The IP address must be consistent with that on the software side of the printer box.

- Search

Search the IP address of the printer box in the current LAN. Search is not supported when the device is directly connected to the print box.

- Port

The default value is 35327. It supports manual input, and the acceptable value ranges from 1025 to 65535.

The port No. must be consistent with that on the software side of the printer box.

5.9 Auxiliary Settings

Click **Auxiliary Settings** in the **Setup** interface to access the **Auxiliary Settings** interface. See Figure 5-44.

Figure 5-44 Auxiliary Settings

The administrator is allowed to set the following functions in the **Auxiliary Settings** interface:

- Sample Numbering Rules
- Startup sample ID and mode
- Predilute
- Other
- Quick Save

Sample Numbering Rules

Set the sample ID entry rules.

- Sample ID Entry Method

Click the dropdown list of the **Sample ID Entry Method** and select the entry method of the sample ID from the following options.

- Auto increment (default setting) : the system adds 1 to the current sample ID as the next sample ID.
- Manual entry: the next sample ID is empty by default and can be entered as required.

- Prefix Length

When **Auto Increment** is selected as the Sample ID entry method, you can add a prefix to a certain batch of samples for identification.

Enter the prefix length ranging from 0 to 24 (e.g. 2) of the sample ID in the **Prefix Length** textbox. The prefix length will be applied to all sample IDs after the setting is saved.

Startup sample ID and mode

Set the sample ID and measurement mode for the next sample after startup.

- Next Sample ID and mode after startup

The sample ID and mode set by the user will be used by the system after the next startup when the specified sample ID is entered into the textbox and the measurement mode (CBC or CBC+DIFF) is selected from the dropdown list.

NOTE

If the **Effective tomorrow** is checked, the modification of the next sample ID and mode after startup will become effective on the next day.

- Continue using the sample ID and mode before the last shutdown

If checked, the system will by default add 1 to the last sample ID analyzed before shutdown as the next sample ID after startup.

Predilute

Set if you wish to see a popup dialog box when you perform the Predilute counting.

- Ask for confirmation (default setting): in the **Predilute** mode, when you press the aspirate key to start the analysis, a dialog box will pop up to remind you that the ongoing analysis is for **Predilute** counting.
- Do not ask for confirmation: the dialog box for confirming the Predilute counting will not pop up.

Quick Save

- "Sample ID" in "Mode" interface

Set whether the Quick Save function is enabled for the **Mode** interface.

- If checked (default setting), when you enter the sample ID and press [Enter] (with the keyboard) or scan the sample ID (with barcode scanner) in the **Mode** interface, the sample information will be saved automatically.
- If unchecked, the sample information should be saved manually.

- "Med Rec. No." in "Pre-entry" interface

Set whether the Quick Save function is enabled for the **Pre-entry** interface.

- If checked, when you enter the Med. Rec. No. in the **Pre-entry** interface and press [Enter] (with the keyboard), the sample information will be saved automatically.
- If unchecked (default setting), the sample information should be saved manually.

Other

- Show Result Edited Flags

It's unchecked by default, which means the edited results are marked with an **M** at the end, while the corresponding results with manual modifications are marked with an **m** at the end. **M** or **m** is displayed between the result data and the parameter unit by default.

If unchecked, the edited result will not be marked with an **M** or **m**.

- Automatically generate the delivery date

It is checked by default, which means you don't need to manually enter the **Delivery Time** when you modify patient information after running a sample. The operating date will be displayed in the date textbox.

If unchecked, the **Delivery Time** shall be manually entered when patient information is modified in **Sample Analysis** interface.

- Automatically generate the sampling date

It is checked by default, which means you don't need to manually enter the **Sampling Time** when you modify patient information after running a sample. The operating date will be displayed in the date textbox.

If unchecked, the **Sampling Time** shall be manually entered when patient information is modified in **Sample Analysis** interface.

- Suspicious Flag

A single character (an English letter only) can be re-entered in the textbox as a suspicious flag. The default value is ?.

- Ref. Range Flags

You can select the **Ref. Range Flags** from the dropdown list. The default high flag is ↑(or H) and the default low flag is ↓ (or L).

5.10 Patient Information

The administrator can set the items of patient information to be displayed as required.

Click **Setup > Patient Information** to access the patient information settings interface. See Figure 5-45.

Figure 5-45 Patient Information Settings

Patient Information		
<input checked="" type="checkbox"/> Sample ID	<input checked="" type="checkbox"/> Area	<input checked="" type="checkbox"/> Submitter
<input checked="" type="checkbox"/> Mode	<input checked="" type="checkbox"/> Bed No.	<input checked="" type="checkbox"/> Operator
<input checked="" type="checkbox"/> Med Rec. No.	<input checked="" type="checkbox"/> Gender	<input checked="" type="checkbox"/> Run Time
<input checked="" type="checkbox"/> First Name	<input checked="" type="checkbox"/> Birthday	<input checked="" type="checkbox"/> Approver
<input checked="" type="checkbox"/> Last Name	<input checked="" type="checkbox"/> Age	<input checked="" type="checkbox"/> Report Time
<input checked="" type="checkbox"/> Patient Type	<input checked="" type="checkbox"/> Ref. Group	<input checked="" type="checkbox"/> Diagnosis
<input checked="" type="checkbox"/> Sample Type	<input checked="" type="checkbox"/> Sampling Time	<input checked="" type="checkbox"/> Remarks
<input checked="" type="checkbox"/> Department	<input checked="" type="checkbox"/> Delivery Time	
		<input type="button" value="OK"/> <input type="button" value="Cancel"/>

All the patient information parameters are displayed by default. If a parameter is not intended to be displayed, uncheck the parameter.

NOTE

Sample ID and **Mode** are fixed and cannot be hidden.

5.11 Thermal Printer Settings (for DF52, DF55 and DF56 only)

NOTE

The thermal printer settings is for DF52, DF55 and DF56 only.

If the printout from the thermal printer is too light or too dark, you can adjust the print density of the thermal printer to improve the print quality. To set the print density of the thermal printer, take the following steps:

1. Click **Thermal Printer Setting** in the **Setup** interface.

The **Thermal Printer Setting** interface pops up shown in Figure 5-46.

Figure 5-46 Thermal Printer Setting

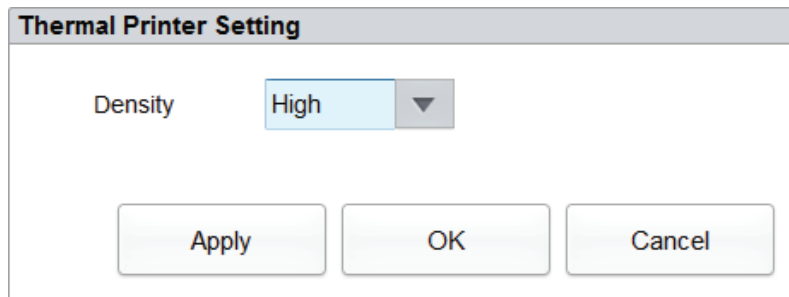

2. Select the print density from the **Density** dropdown list.
 - If the printout is too light, select **Medium** or **High** to darken the density.
 - If the printout is too dark, select **Medium** or **Low** to lighten the density.
3. Click **Apply** or **OK**.

A dialog pops up as shown in Figure 5-47.

Figure 5-47 Thermal Printer Setting Successful

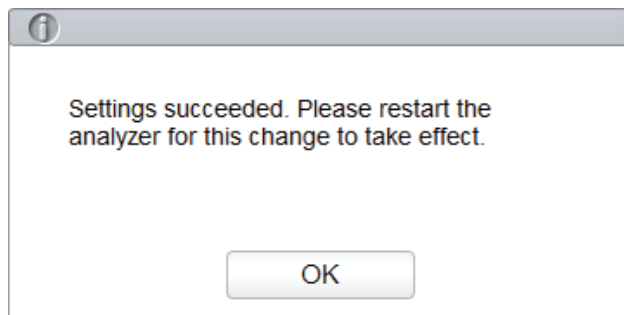

4. Restart the analyzer: turn to [O] the [O/I] switch located at the back of the analyzer; after 10 seconds approximately, turn to [I].
5. Perform a print operation to check print quality of the thermal printer.
If the problem persists, redo the above procedures until the print density meets the requirements.

6 Daily Operations

6.1 Introduction

This chapter introduces the daily operations from the startup to the shutdown of the analyzer.

A flow chart indicating the common daily operation process is presented below.

Figure 6-1 Daily Operations Procedure

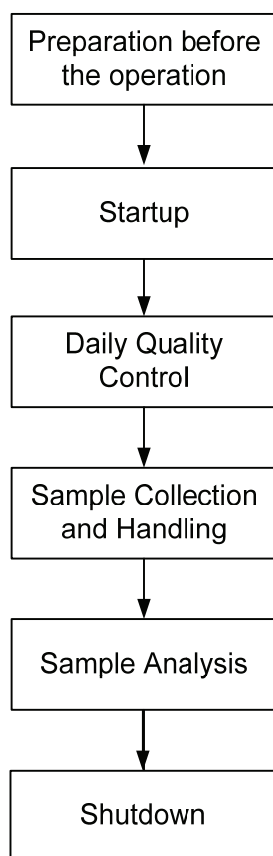

6.2 Pre-operation Preparation



All the samples, controls, calibrators, reagents, wastes and areas in contact with them are potentially biohazardous. Wear proper personal protective equipment (e.g. gloves, lab uniforms, etc.) and follow laboratory safety procedures when handling them and the relevant areas in the laboratory.

**WARNING**

- Be sure to dispose of reagents, waste, samples, consumables, etc. according to local legislations and regulations.
- Reagents can be irritating to the eyes, skin, and mucosa. Wear proper personal protective equipment (e.g. gloves, lab uniforms, etc.) and follow laboratory safety procedures when handling them in the laboratory.
- If the reagent accidentally comes in contact with your skin, wash it off immediately with plenty of water and see a doctor if necessary. Do the same if you accidentally get any of the reagent in your eyes.
- Keep your clothes, hairs and hands away from the moving parts to avoid injury.
- The sample probe tip is sharp and may contain biohazardous materials. Exercise caution to avoid contact with the probe when working around it.

NOTE

- You should only use the Dymind-specified reagents. Store and use the reagents as specified in instructions for use of the reagents.
- Check if the reagents are connected correctly before using the analyzer.
- After long-distance transportation, the reagent must be allowed to settle for more than one day before use.
- Be sure to use clean K₂EDTA vacutainer blood collection tubes with anticoagulant, fused silica glass/plastic test tubes, centrifugal tubes and borosilicate glass capillary tubes.
- Be sure to use the Dymind-specified disposable products including vacutainer blood collection tube, vacutainer blood collection tubes with anticoagulant and capillary tubes etc.

Perform the following checks before turning on the analyzer.

- Waste container
Check and make sure the waste container is empty.
- Fluidic tubing and power connections
Check and make sure the reagents and waste tubing are properly connected and not bent.
Check and make sure the power cord of the analyzer is properly plugged into the power outlet.
- Printer (Optional)
Check and make sure enough paper is installed.
Check and make sure the power cord of the printer is properly plugged into power outlet, and the printer is properly connected to the peripheral computer.
- Network Cable (Optional)
Check and make sure the network cable is properly connected to the analyzer.

6.3 Startup

This section introduces the operations related to the startup of the analyzer.

NOTE

- If you failed to start the analyzer continuously, please contact Dymind customer service department or your local agent immediately.
- After startup, please make sure the data/time displayed on the screen is correct.

1. Place the power switch at the back of the analyzer in the [I] position.

The power indicator light will be on.

2. Check the indicator light on the analyzer.

If the indicator light is on, it indicates the analyzer has been started up. The analyzer will perform self-test and initialization in sequence. The whole process will last for 4 to 10 minutes. (Time needed for initializing the fluidic systems depends on how the analyzer was previously shut down.)

3. Enter the correct user name and password in the Login message box. See Figure 6-2.

Figure 6-2 Login

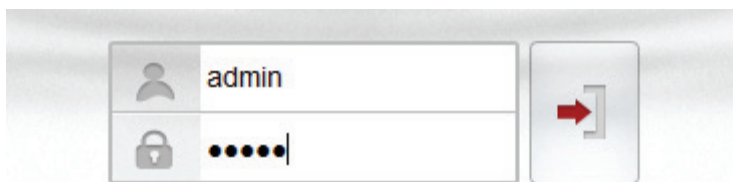

The initial user name and password of administrator are **admin**, which was set by service engineer.

1 to 12 digits of numeric characters can be entered for the user name and the password. No Chinese character is allowed.



NOTE

You can click  to select whether the login password is visible.

4. Click  to enter the user interface.

The system will display the **Sample Analysis** screen by default and display the test result of the background when the analyzer is started.

NOTE

- The background test is designed for detecting particle interference and electrical interference.
- For the background reference range of each parameter, please see **A.4.2 Normal Background**.
- The sample ID for the background test is **background**.
- If the background results exceed the Ref. Range for the first time during fluidics initialization, then the analyzer will run the background test one more time.
- Running a test when there is a Background abnormal, you would obtain an unreliable testing result.
- If any error is detected during initialization (e.g. the background results exceed the **Ref. Range**), the analyzer will activate the alarm. For details, see **13 Troubleshooting**.
- To lock or switch a user, click  on the menu screen and click **Yes** on the pop-up dialog box. The system will return to the login dialog box. Enter the user name and password, click , then you can log in again or log in the software interface with another user identity.

6.4 Daily Quality Control

To ensure reliable analysis results, conduct daily QC analysis on the analyzer before running samples. For details, see **9 Quality Control**.

6.5 Sample Collection and Handling



All the samples, controls, calibrators, reagents, wastes and areas in contact with them are potentially biohazardous. Wear proper personal protective equipment (e.g. gloves, lab uniforms, etc.) and follow laboratory safety procedures when handling them and the relevant areas in the laboratory.

**WARNING**

Do not touch the patients' blood sample directly.

**CAUTION**

- Do not re-use such disposable products as collection tubes, test tubes, capillary tubes, etc.
- Prepare the samples as per the procedures recommended by the reagent manufacturer.

NOTE

- Be sure to use clean K₂EDTA vacutainer blood collection tubes with anticoagulant, fused silica glass/plastic test tubes, centrifugal tubes and borosilicate glass capillary tubes.
 - Be sure to use the Dymind-specified disposable products including vacutainer blood collection tube, vacutainer blood collection tubes with anticoagulant and capillary tubes etc.
 - For the whole blood samples to be used for WBC classification or PLT count, store them at room temperature and run them within 8 hours after collection.
 - If you do not need the PLT, MCV and WBC differential results, you can store the samples in a refrigerator (2°C - 8°C) for 24 hours. You need to warm the keep samples at room temperature for at least 30 minutes before running them.
 - Be sure to mix any sample that has been prepared for a while before running it.
-

6.5.1 Venous Whole Blood Samples

The procedure for preparing venous whole blood sample is as follows:

1. Use clean K₂EDTA (1.5mg/mL~2.2mg/mL) vacutainer blood collection tubes with anticoagulant to collect venous blood samples.
 2. Mix the venous blood with the anticoagulant well in the tube immediately.
-

**CAUTION**

For vacutainer blood collection tube (Φ12X75, cap excluded), please make sure the volume of the whole blood sample is not less than 0.5mL.

6.5.2 Capillary Whole Blood Samples

Collect the capillary whole blood sample with a vacuum blood collection tube specified by the manufacturer.

**CAUTION**

To ensure the accuracy of the analysis, make sure the volume of the capillary whole blood sample is not less than 100μL.

NOTE

- Run the capillary whole blood sample within 3 minutes to 2 hours after its collection.
 - The tube shall be placed vertically upward, not tilted or upside down. Otherwise, the inner wall of the tube may be stained with excessive sample, resulting in waste. Moreover, it may cause unevenly mixed sample and unreliable analysis results.
-

6.5.3 Prediluted Samples



CAUTION

Do not use anticoagulant during the prediluted sample analysis procedure; otherwise, the analysis result will be affected.

NOTE

Be sure to evaluate predilute stability based on your laboratory's sample population and sample collection techniques or methods.

The procedure for preparing prediluted sample is as follows:

1. Click the  on the top left corner and enter the menu screen as shown in Figure 6-3.

Figure 6-3 Menu Screen



2. Click the **Add Diluent** icon.

A prompt box will pop up on the screen as shown below. See Figure 6-4.

Figure 6-4 Add Diluent

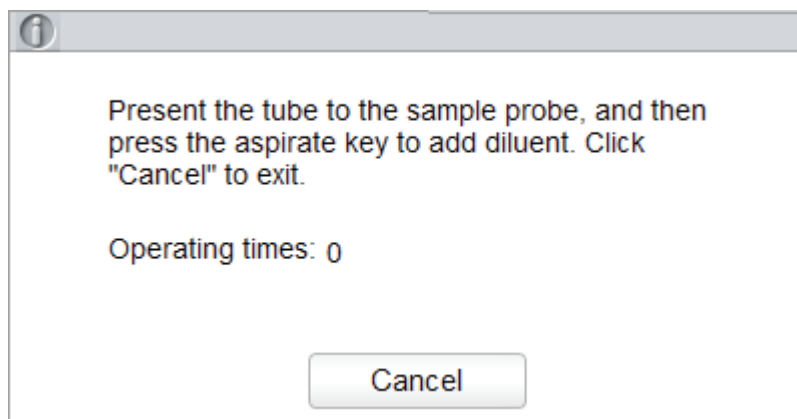

3. Take a clean centrifugal tube, uncap it and present it to the sample probe in a manner as shown in the following picture in which the probe tip is vertically in contact with the bottom of the tube so as to avoid bubbles, liquid attached to the inner wall or spatter.

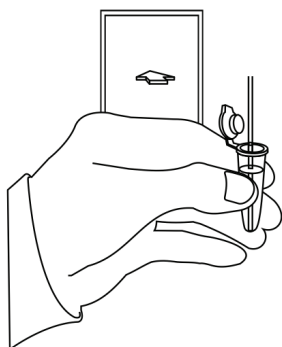

4. Press the aspirate key and add the diluent (480 μ L at a time). After the diluent is added and you hear a beep, you can remove the centrifugal tube.

NOTE

- You can also dispense 480 μ L of diluent by pipette into the tube.
- Be sure to keep dust from the prepared diluent.

5. If more portions of diluent are needed, repeat steps 3~4.
6. Add 20 μ L of blood to the diluent, close the tube cap and shake the tube to mix the sample.
7. After the prediluted sample is prepared, click **Cancel** to exit dispensing the diluent.

NOTE

- The prediluted sample prepared after single blood collection can be counted twice.
- Be sure to run the prediluted samples within 30 minutes after the mixing.
- Be sure to mix any sample that has been prepared for a while before running it.
- The centrifugal tube shall be placed vertically upward, not tilted or upside down. Otherwise, the inner wall of the tube would be stained with excessive sample, resulting in waste. Moreover, it may cause unevenly mixed sample and unreliable analysis results.

6.6 Sample Analysis

After the sample is prepared, you can perform the operations for sample analysis.

For details, see **7 Sample Analysis**.

6.7 Shutdown



All the samples, controls, calibrators, reagents, wastes and areas in contact with them are potentially biohazardous. Wear proper personal protective equipment (e.g. gloves, lab uniforms, etc.) and follow laboratory safety procedures when handling them and the relevant areas in the laboratory.



The sample probe is sharp and potentially biohazardous. Exercise caution to avoid contact with the probe when working around it.



CAUTION

Do not turn on the analyzer immediately after its shutdown. Wait at least 10 seconds before power-on to avoid damage to the machine.

NOTE

- To ensure stable analyzer performance and accurate analysis results, be sure to perform the Shutdown procedure to shut down the analyzer after it has been running continuously for 24 hours.
 - When the analyzer is running or performing other fluidics sequence, do not force shutdown the analyzer.
 - If any error is detected during shutdown procedure, the analyzer will return to the status before the shutdown procedure is performed, and then activate the alarm. See **13 Troubleshooting** for details of removing the error.
 - Be sure to shut down the analyzer in strict accordance with the instruction below.
-

Procedures for shutting down the analyzer are as follows:

1. Click the  button on the menu screen.

The interface pops up a dialog box as shown below.

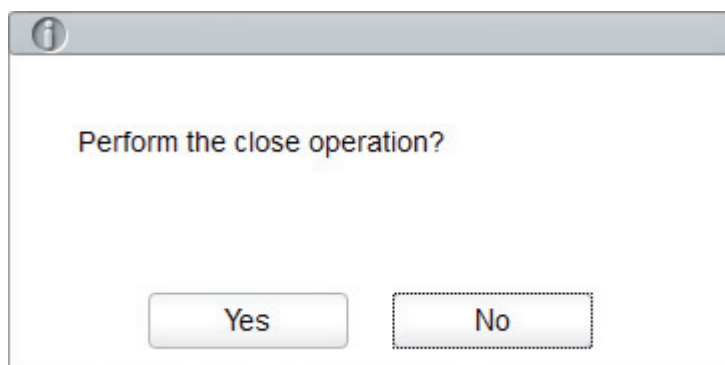

2. Click **Yes**.

The system starts to execute the shutdown sequence and a message box pops up showing the procedures for cleanser maintenance.

3. Follow the instructions and set the cleanser under the sample probe, and press the aspirate key on the analyzer or click **Aspirate** to run the cleanser aspiration.

Upon the completion of cleanser maintenance, you'll be prompted that the cleanser maintenance is completed.

Shutdown done. Please power off the analyzer!

4. Place the [O/I] switch at the back of the main unit in the [O] position.
5. After shutdown, empty the waste in the waste container, and dispose of it.



WARNING

Be sure to dispose of reagents, waste, samples, consumables, etc. according to local legislations and regulations.

7 Sample Analysis

7.1 Introduction

Sample analysis is the most important function of the auto hematology analyzer. You can get the blood cell count, HGB concentration and the 5-part classification counting results of the white blood cells by performing the sample analysis.

The summary of sample analysis procedures are as follows:

1. Entering the sample information.
2. Running the samples.
3. Processing the analysis results.

7.2 Interface Introduction

The **Sample Analysis** interface is the main interface of the analyzer (Figure 7-1). You can complete the operations such as entering the sample information, performing sample analysis, reviewing/printing analysis results in the **Sample Analysis** interface.

Figure 7-1 Sample analysis interface

Patient information area **Function buttons**

The screenshot shows the Sample Analysis interface with the following components:

- Navigation Buttons:** Previous, Next, Mode & ID, Pre-entry, Validate, Print, Custom Para., Microscopic Exam Para.
- Patient Information:** Sample ID: Forge482, Mode: VWB-CBC+DIFF, Age: , Name: , Run Time: 2015/02/10 02:20:35, Gender: .
- Analysis Results Table:**

Para.	Result	Unit	Para.	Result	Unit
WBC	↓ 3.05	10 ⁹ /L	RBC	3.73	10 ¹² /L
Neu%	0.523		HGB	↓ 0.7	mmol/L
Lym%	0.369		HCT	↓ 0.349	L/L
Mon%	0.070		MCV	93.6	fL
Eos%	0.029		MCH	192	amol
Bas%	0.009		MCHC	↓ 2.0	mmol/L
Neu#	↓ 1.60	10 ⁹ /L	RDW-CV	↓ 0.107	
Lym#	1.13	10 ⁹ /L	RDW-SD	43.3	fL
Mon#	0.22	10 ⁹ /L	PLT	263	10 ⁹ /L
Eos#	0.08	10 ⁹ /L	MPV	8.8	fL
Bas#	0.02	10 ⁹ /L	PDW	16.0	
*ALY#	0.01	10 ⁹ /L	PCT	2.32	mL/L
*ALY%	0.005				
*LIC#	0.00	10 ⁹ /L			
*LIC%	0.000				
- WBC Message:** WBC histogram.
- RBC Message:** RBC histogram.
- PLT Message:** PLT histogram.
- LS, DIFF, MS:** Scatter plots for Leukocyte Scatter (LS), Differential (DIFF), and Mean Scatter (MS).
- Footer:** Next Sample: 23, Sample Count, Mode: VWB-CBC+DIFF, User: admin, 2015/12/29 17:11:02.

Analysis results area **Information of the next sample**

Related descriptions:

- Function buttons

You can perform operations such as setting the mode for the samples, pre-entering information, reviewing previous/next records and printing. Click  and view all function buttons. See section **7.6 Functions of the Buttons**.

- Patient information area

It displays the patient information corresponding to the current sample.

- Analysis results area

It displays the analysis results of the sample, including the parameter results, Flags, DIFF scattergrams, BASO scattergram and histograms (including WBC, RBC and PLT). The system displays the analysis results of the most recent run by default.

- Parameter Results

This list displays the analysis results of all the parameters of the samples.

You can compare the values in the **Result** column with the corresponding **Ref. Range**. If the values are within the reference range, it means that they are normal. If not, it indicates that the sample may be abnormal and the corresponding symbols will be displayed in the **Flag** column.

- WBC Message

Displays the alert message regarding the WBC.

- RBC Message

Displays the alert message regarding the RBC.

- PLT Message

Displays the alert message regarding the platelet.

- DIFF

WBC DIFF scattergram in the CBC+DIFF mode. Click the scattergram, three WBC DIFF scattergrams including LS-MS, LS-HS and HS-MS and one BASO scattergram will be displayed.

- WBC

WBC distribution histogram. You can click the histogram for an enlarge view, and click again to reinstate.

- RBC

RBC distribution histogram. You can click the histogram for an enlarge view, and click again to reinstate.

- PLT

Platelet distribution histogram. You can click the histogram for an enlarge view, and click again to reinstate.

- Information of the next sample

It displays the sample ID and analysis mode of the next sample.

7.3 Entering Sample Information

You can enter the worklist information of the samples to be tested before the analysis.

NOTE

- If the **Bidirectional LIS/HIS Communication** is checked and the sample information is **Matched by Sample ID** in the **Setup > Communicate > LIS Communication** interface, you don't need to pre-enter the sample information. The analyzer automatically obtains the patient information from HIS/HIS by the sample ID entered in the **Mode** or **Worklist** interface. For details, see **5.6 Communication**.
- If the **Bidirectional LIS/HIS Communication** is checked and the sample information is **Matched by Med Rec. No.** in the **Setup > Communicate > LIS Communication** interface, you only need to enter the **Med. Rec. No.**. The analyzer obtains the other information of sample from LIS/HIS.
- You can also enter sample/patient information after the sample analysis is completed. For details, please refer to **8 Result Review**.

Detailed steps are shown below:

1. Click the **Pre-entry** button in the function button area.

The interface as shown in Figure 7-2 will pop up on the screen.

Figure 7-2 Pre-entering Patient Information



The screenshot shows a 'Pre-entry' dialog box with the following fields and controls:



First Name	<input type="text"/>	Last Name	<input type="text"/>
Patient Type	<input type="text"/> ▼	Med Rec. No.	<input type="text"/>
Gender	<input type="text"/> ▼	Age	<input type="text"/> Year ▼
Birthday	<input type="text"/> // ▼	Ref. Group	General ▼
Sample Type	<input type="text"/> ▼	Department	<input type="text"/> ▼
Submitter	<input type="text"/> ▼	Area	<input type="text"/> ▼
Bed No.	<input type="text"/> ▼	Sampling Time	2018/09/10 09:44 ▼
Delivery Time	2018/09/10 09:44 ▼		
Remarks	<input type="text"/>		



At the bottom of the dialog box are three buttons: **Apply**, **OK**, and **Cancel**.

2. Enter patient information with reference to the parameter description in Table 7-1.

Table 7-1 Parameter Description

Parameter	It means	Operation
First Name	First name of patient.	Input in the textbox directly.
Last Name	Last name of patient.	Input in the textbox directly.
Patient Type	Type of patient. Values: <ul style="list-style-type: none"> • (Null) • Inpatient • Physical Exam • STAT • Outpatient 	Select from the dropdown list.
Sample Type	Type of sample for microscopic examination. Values: <ul style="list-style-type: none"> • Venous blood • Capillary • Cord blood • Blood 	Click the Sample Type dropdown list box and select the type of sample for microscopic examination.
Med Rec. No.	Medical record number of patient.	Input in the textbox directly.
Gender	Gender of patient. Values: <ul style="list-style-type: none"> • (Null) • Male • Female • Not defined 	Select from the dropdown list.
Birthday	Birthday of a patient.	Select from the date control. <ul style="list-style-type: none"> • The input sequence of the controls is the same with the date format on the top right corner of the dialog box. For example, if the data format is yyyy/MM/dd, you should input the data in the sequence of year, month, and date. • Click  or  to select the date or click the textbox to enter them directly. • Click  to clear the current data and re-enter the information.
Age	Age of a patient.	Select the unit of age from the dropdown list (Year, Month, Week, Day or Hour) and enter the age of the patient in the textbox before the age unit. <p>NOTE</p> <p>If the Birthday is set, the age will be displayed automatically.</p>

Parameter	It means	Operation
Ref. Group	Reference group of the sample under analysis. The result is judged according to the reference range of the reference group and the result beyond the normal range will be flagged.	Select from the dropdown list. NOTE <ul style="list-style-type: none"> If the Automatically match the customized reference group according to age and gender is set, gender and age of a patient will automatically match the reference group according to the corresponding relationship (No matter the reference group is selected or not). Refer to 5.4.3 Ref. Range for the setting of the reference group and range.
Department	Department receiving the patient.	Select from the dropdown list.
Area	Ward area of patient.	Input in the textbox directly.
Bed No.	Bed No. of inpatient.	Select from the dropdown list or input directly. NOTE The bed No. is required to be filled only for inpatients.
Sampling Time	Date and time when the sample is collected.	Click the date control for the settings. <ul style="list-style-type: none"> The input sequence of the controls is the same with the date format on the top right corner of the dialog box. For example, if the data format is yyyy/MM/dd HH:mm, you should input the data in the sequence of year, month, date, hour, and minute. Click  or  to select the date or click the textbox to enter them directly. Click  to clear the current data and re-enter the information. NOTE <ul style="list-style-type: none"> The system automatically displays the current time as sampling time. The sampling time can be no later than the current system time.
Submitter	Personnel submitting the sample.	Select from the dropdown list or input directly.

Parameter	It means	Operation
Delivery Time	Date and time when the sample is delivered.	<p>Click the date control for the settings.</p> <ul style="list-style-type: none"> The input sequence of the controls is the same with the date format on the top right corner of the dialog box. For example, if the data format is yyyy/MM/dd HH:mm, you should input the data in the sequence of year, month, date, hour, and minute. Click  or  to select the date or click the textbox to enter them directly. Click  to clear the current data and re-enter the information. <p>NOTE</p> <ul style="list-style-type: none"> The system automatically displays the current time as sample delivery time. The delivery time can be no later than the current system time and cannot be earlier than the sampling time.
Remarks	Clarifications or notes.	Input in the textbox directly.

- Click **Apply** or **OK** to save the configuration.

7.4 Running Samples



All the samples, controls, calibrators, reagents, wastes and areas in contact with them are potentially biohazardous. Wear proper personal protective equipment (e.g. gloves, lab uniforms, etc.) and follow laboratory safety procedures when handling them and the relevant areas in the laboratory.



WARNING

The sample probe tip is sharp and may contain biohazardous materials. Exercise caution to avoid contact with the probe when working around it.



CAUTION

- Do not re-use such disposable products as collection tubes, test tubes, capillary tubes, etc.
- Make sure that the entered sample ID and mode exactly match those of the samples to be run.

NOTE

- The tube (or centrifugal tube) shall be placed vertically upward, not tilted or upside down. Otherwise, the inner wall of the tube may be stained with excessive sample, resulting in waste. Moreover, it may cause unevenly mixed sample and unreliable analysis results.
 - During aspiration, the tip of the probe should be kept at a certain distance from the bottom of the sample container, otherwise the accuracy of aspiration volume will be affected.
 - Keep the tip of the probe from contacting with the wall of the test tube to avoid blood splashing.
 - Proper reference range shall be selected on the **Setup** interface before analysis. Otherwise, the results may be flagged erroneously.
 - The default system setting for counting mode is **Venous Whole Blood (VWB)-CBC+DIFF**.
 - When the analyzer is running the samples, you can switch to **Review** interface to perform operations including browsing and exporting, etc., and you can also switch to other interfaces. But all the functions related to the fluidics sequence are not available.
-

Take the following steps to perform sample analysis.

1. Prepare samples as instructed by **6.5 Sample Collection and Handling**.
 - For details about the preparation of venous whole blood samples, see **6.5.1 Venous Whole Blood Samples**.
 - For details about the preparation of capillary whole blood samples, see **6.5.2 Capillary Whole Blood Samples**.
 - For details about the preparation of prediluted samples, see **6.5.3 Prediluted Samples**.
2. Shake the capped tube of sample for a homogeneous specimen.
3. When the green indicator light is steady-on, click **Mode & ID** in **Sample Analysis** interface.

A dialog box will pop up as shown in Figure 7-3. The analyzer supports six counting modes: venous whole blood (VWB)-CBC, venous whole blood (VWB)-CBC+DIFF, capillary whole blood (CWB)-CBC, capillary whole blood (CWB)-CBC+DIFF, Predilute(PD)-CBC, and Predilute(PD)-CBC+DIFF.

Figure 7-3 Mode & ID Settings

4. Select the blood sample mode **Venous Whole Blood (VWB)**, **Capillary Whole Blood (CWB)** or **Predilute (PD)** of the sample.
5. Select the measurement mode **CBC** or **CBC+DIFF** according to the actual test case, and enter the **Sample ID**.

Refer to Table 7-2 for the description of relevant parameters.

Table 7-2 Sample Analysis Parameter Descriptions

Parameter	It means	Operation
Venous whole blood (VWB)	Analyzing the venous whole blood samples.	Selected from the radio box.
Capillary whole blood (CWB)	Analyzing the capillary whole blood samples.	Selected from the radio box.
Predilute(PD)	Analyzing the prediluted samples.	Selected from the radio box.
CBC	Complete Blood Count with no differential count for white blood cells. The counting results comprise 13 parameters, 3 histograms (including WBC, RBC and PLT), and one BASO scattergram.	Selected from the radio box.

Parameter	It means	Operation
CBC+DIFF	Complete Blood Count plus differential count for white blood cells. The counting results comprise 23 measurement parameters, 4 or 6 RUO parameters, one DIFF scattergram, one BASO scattergram, and three histograms (including WBC, RBC and PLT).	Selected from the radio box.
Sample ID	Identification number for the samples to be run.	Enter in the textbox directly. NOTE <ul style="list-style-type: none"> • Letters, numbers and all characters that can be entered through the keyboard (including special characters) are allowed for the Sample ID. Chinese and other languages (such as Japanese, Korean, etc) are not supported. • The length of the entries ranges from 1 to 25 and the entries shall not be empty. • If the sample ID entry method is auto increment, the last character of a sample ID must be numeric, but a string of "0" only is not an acceptable sample ID. See 5.9 Auxiliary Settings for the setting of sample ID entry method.
Bidirectional LIS/HIS communication	Checking whether LIS/HIS communication is set in the software system.	Non-editable. It is the same as that set by the user on the interface of LIS Communication .

6. Click **OK**.
7. Remove the tube cap carefully and place the sample under the probe so that the probe can aspirate the well-mixed sample.
8. Press the aspirate key on the analyzer to start running the sample.
The sample will be automatically aspirated by the sample probe.
9. When you hear a beep, remove the sample tube.
The analyzer will automatically run the sample and the analysis status icon and analyzer indicator is flickering in green. When the analysis is complete, the analyzer indicator returns to constantly-on green.
10. Repeat steps 1~9 to run the remaining samples.

7.5 Dealing with the Analysis Results

7.5.1 Automatic saving of analysis results

This analyzer automatically saves sample results. When the maximum number has been reached, the newest result will overwrite the oldest (already backed up).

7.5.2 Parameter Flags

- If parameter is followed by a “↑” or “↓”, it means the analysis result has exceeded the upper or lower limit of the reference range but still within the display range.
- If the parameter is followed by a “?”, it means the analysis result is suspicious.
- If you see “****” instead of a result, it means the result is either invalid or beyond the display range.

NOTE

For the background test, the flags for parameters or abnormal blood cell differential and morphology are not available.

7.5.3 Flags of Abnormal Blood Cell Differential or Morphology

The analyzer will flag abnormal or suspicious WBC, RBC and PLT according to the scattergrams and histograms. The flag information is defined in the table below.

Table 7-3 Flags of abnormal blood cell differential or morphology

Flag Type		Flag information
WBC	Abnormal	Leucocytosis
		Leucopenia
		Neutrophilia
		Neutropenia
		Lymphocytosis
		Lymphopenia
		Monocytosis
		Eosinophilia
		Basophilia
	Suspicious	WBC abnormal
		Abnor. WBC scattergram
		Abnor. WBC histogram
		Left Shift?

Flag Type		Flag information
		Immature Cell?
		RBC Lyse Resistant?
		Abnor./Atypical Lym?
		Abnormal WBC Channel
		Abnormal DIFF Channel
RBC/HGB	Abnormal	Erythrocytosis
		Anisocytosis
		Macrocytosis
		Microcytosis
		Anemia
		Hypochromia
	Suspicious	Abnor. RBC Distr.
		Dimorphologic
		Iron Deficiency?
		HGB Abnor./Interfere?
		RBC Clump?
		Abnormal RBC Channel
		Abnormal HGB Channel
PLT	Abnormal	Thrombocytosis
		Thrombopenia
	Suspicious	Abnor. PLT Distr.
		PLT Clump?

The system shows flags for abnormal or suspicious items in different samples and measurement modes in accordance with the impact of the abnormal or suspicious WBC, RBC or PLT items on the results of the parameters. The correlation is shown in the following table.

Table 7-4 Flags for abnormal or suspicious items in different samples and measurement modes

Type	Flag	Whole Blood		Predilute (PD)	
		CBC	CBC+DIFF	CBC	CBC+DIFF
WBC	WBC abnormal?	√	√	√	√
	RBC Lyse Resistant?	×	√	×	√
	Abnor. WBC scattergram	×	√	×	√
	Abnor. WBC histogram	√	√	√	√

Type	Flag	Whole Blood		Predilute (PD)	
		CBC	CBC+DIFF	CBC	CBC+DIFF
	Left Shift?	x	√	x	√
	Immature Cell?	x	√	x	√
	Abnor./Atypical Lym?	x	√	x	√
	Leucocytosis	√	√	√	√
	Leucopenia	√	√	√	√
	Neutrophilia	x	√	x	√
	Neutropenia	x	√	x	√
	Lymphocytosis	x	√	x	√
	Lymphopenia	x	√	x	√
	Monocytosis	x	√	x	√
	Eosinophilia	x	√	x	√
	Basophilia	x	√	x	√
	Abnormal WBC Channel	x	√	x	√
	Abnormal DIFF Channel	x	√	x	√
	RBC/HGB	Dimorphologic	√	√	√
HGB Abnor./Interfere?		√	√	√	√
Anisocytosis		√	√	√	√
Microcytosis		√	√	√	√
Macrocytosis		√	√	√	√
Erythrocytosis		√	√	√	√
Anemia		√	√	√	√
Hypochromia		√	√	√	√
Abnor. RBC Distr.		√	√	√	√
Iron Deficiency?		√	√	√	√
RBC Clump?		√	√	√	√
Abnormal RBC Channel		√	√	√	√
Abnormal HGB Channel		√	√	√	√
PLT	PLT Clump?	√	√	√	√
	Thrombocytosis	√	√	√	√
	Thrombopenia	√	√	√	√
	Abnor. PLT Distr.	√	√	√	√

NOTE

- "√" indicates that flags will be displayed in the mode."×" indicates that flags will not be displayed in the mode.
 - When the PLT value is less than $100 \times 10^9 /L$, a manual count by the microscope is recommended.
-

7.6 Functions of the Buttons

7.6.1 Previous/Next

Click **Previous**, and the screen will display the sample analysis results prior to the current one.

Click **Next**, and the screen will display the sample analysis results after the current one.

7.6.2 Mode & ID

Click this button to set the sample mode and measurement mode during the sample analysis. See section **7.4 Running Samples**.

7.6.3 Pre-entry

Click this button, and you can pre-enter the information of the sample to be tested before performing the sample analysis. See section **7.3 Entering Sample Information**.

7.6.4 Validate/Cancel Validation

After running sample, you can click **Validate** to validate the sample. After validating, the button will be replaced by **Cancel Validation**. After validating, you can not edit the sample/patient information and the result.

If the current sample has been validated, the sample validation can be canceled by clicking **Cancel Validation**. After canceling the validation, you can edit the sample/patient information and the result.

7.6.5 Print

You can click **Print** to print the report of the sample result.

7.6.6 Patient Information

You can browse and edit the patient information of the selected sample in the **Sample Analysis** interface. The operation procedures are as shown below:

1. Click **Patient Info.** to enter the patient information setting interface as shown in Figure 7-4.

NOTE

You can press the shortcut key [F4] to enter the **Patient Info.** interface when the peripheral keyboard is connected to the analyzer.

Figure 7-4 Patient Information

The screenshot shows a 'Patient Info.' form with the following fields and values:



- First Name: (empty)
- Last Name: (empty)
- Sample ID: 1
- Patient Type: (dropdown menu)
- Sample Type: (dropdown menu)
- Department: (dropdown menu)
- Med Rec. No.: (empty)
- Area: (dropdown menu)
- Bed No.: (dropdown menu)
- Gender: (dropdown menu)
- Birthday: // (dropdown menu)
- Age: (empty) Year (dropdown menu)
- Ref. Group: General (dropdown menu)
- Sampling Time: 2016/04/13 15:01 (dropdown menu)
- Delivery Time: 2016/04/13 15:01 (dropdown menu)
- Submitter: (dropdown menu)
- Operator: admin
- Run Time: 2016/04/13 15:01 (dropdown menu)
- Mode: VWB-CBC+DIFF
- Approver: (empty)
- Report Time: // : (dropdown menu)
- Diagnosis: (empty)
- Remarks: (empty)







Buttons at the bottom: Apply, OK, Cancel

2. Enter patient information with reference to the parameter description in Table 7-5.

Table 7-5 Parameter Description of Patient Information

Parameter	Meaning	Operation
Sample ID	Number of the selected sample.	It will be displayed automatically, and you can modify it manually.
First Name	First name of patient.	Input in the textbox directly.
Last Name	Last name of patient.	Input in the textbox directly.
Patient Type	Type of patient. Values: <ul style="list-style-type: none"> • Inpatient • Physical Exam • STAT • Outpatient 	Select from the dropdown list.

Parameter	Meaning	Operation
Sample Type	Type of selected sample. <ul style="list-style-type: none"> • Venous blood • Capillary • Cord blood • Blood 	Select from the dropdown list.
Med Rec. No.	Med Rec. No. of patient.	Input in the textbox directly.
Gender	Gender of patient. Values: <ul style="list-style-type: none"> • (Null) • Male • Female • Not defined 	Select from the dropdown list.
Birthday	Birthday of a patient.	Select from the date control. <ul style="list-style-type: none"> • The input sequence of the controls is the same with the date format on the top right corner of the dialog box. For example, if the data format is yyyy/MM/dd, you should input the data in the sequence of year, month, and date. • Click  or  to select a date and time or enter the information in the textbox directly. • Click  to clear the current data and re-enter the information.
Age	Age of a patient.	Select the unit of age from the dropdown list (Year, Month, Week, Day or Hour) and enter the age of the patient in the textbox before the age unit.
Ref. Group	Reference group of the sample under analysis. The result is judged according to the reference range of the reference group and the result beyond the normal range will be flagged.	Select from the dropdown list. NOTE <ul style="list-style-type: none"> • If the Automatically match the customized reference group according to age and gender is set, gender and age of a patient will automatically match the reference group according to the corresponding relationship (No matter the reference group is selected or not). • Refer to 5.4.3 Ref. Range for the setting of the reference group and range.
Department	Department receiving the patient.	Select from the dropdown list.
Area	Ward area of patient.	Input in the textbox directly.

Parameter	Meaning	Operation
Bed No.	Bed No. of inpatient.	Select from the dropdown list or input directly. NOTE The bed No. is required to be filled only for inpatients.
Sampling Time	Date and time when the sample is collected.	Click the date control for the settings. <ul style="list-style-type: none"> The input sequence of the controls is the same with the date format on the top right corner of the dialog box. For example, if the data format is yyyy/MM/dd HH:mm, you should input the data in the sequence of year, month, date, hour, and minute. Click  or  to select a date and time or enter the information in the textbox directly. Click  to clear the current data and re-enter the information. NOTE The sampling time can be no later than the current system time.
Submitter	Personnel submitting the sample.	Select from the dropdown list or input directly.
Mode	Counting mode of the selected sample. The format is <i>blood sample mode-measurement mode</i> .	You do not need to enter it and it will be displayed automatically.
Delivery Time	Date and time when the sample is delivered.	Click the date control for the settings. <ul style="list-style-type: none"> The input sequence of the controls is the same with the date format on the top right corner of the dialog box. For example, if the data format is yyyy/MM/dd HH:mm, you should input the data in the sequence of year, month, date, hour, and minute. Click  or  to select a date and time or enter the information in the textbox directly. Click  to clear the current data and re-enter the information. NOTE The delivery time can be no later than the current system time and cannot be earlier than the sampling time.
Operator	Personnel running the sample.	You do not need to enter it and it will be displayed automatically.

Parameter	Meaning	Operation
Run Time	Time when the sample is run.	You do not need to enter it and it will be displayed automatically.
Approver	Personnel validating the sample.	This parameter will be automatically displayed after the sample is validated.
Report Time	The date and time when the report is printed for the first time.	This parameter will be automatically displayed after the report is printed.
Diagnosis	Suspected diagnosis information.	Input in the textbox directly.
Remarks	Clarifications or notes.	Input in the textbox directly.

3. Click **Apply** or **OK** to save the settings.

7.6.7 Customized Parameters

You can browse and edit the customized parameters results of the selected sample in the **Sample Analysis** interface. The procedures are shown as below:

1. Click **Custom Para.** to enter the customized parameters setting interface as shown in Figure 7-5.

Figure 7-5 Customized Parameters

The screenshot shows a window titled "Custom Para." containing a table with the following data:

Para.	Flag	Value	Unit	Range
Blood Type				
RH Blood Group				
ESR				
C-reactive Protein				
Reticulocyte				

At the bottom of the window, there are three buttons: "Apply", "OK", and "Close".

2. Click the cell corresponding to its **Value** column of the parameter, and enter the value.
If the unit and reference range of parameters have been set in the **Setup > Parameter > Custom Para.** interface, the corresponding unit and range (lower limit~upper limit) will be

displayed in this tab. When both the value and range of parameters are numbers, and the number is out of the reference range, the relevant mark ↑ or ↓ will be displayed in the **Flag** column.

Please refer to **5.4.6 Customized Parameters** for customized parameters settings.

7.6.8 Microscopic Exam Parameters

You can perform the microscopic exam. settings as per the following steps.

1. Click **Microscopic Exam Para.**

The microscopic examination parameters interface as shown in Figure 7-6 will pop up on the screen.

Figure 7-6 Adding a New Microscopic Exam Parameter

Parameter Name	Value	Flag
Neutrophilic segmented granulocyte		
Neutrophilic band granulocyte		
Lymphocyte		
Monocyte		
Eosinophil		
Basophil		
Plasmacyte		
Atypical Lymph		
Blast		
Promyelocyte		
Neutrophilic myelocyte		
Eosinophilic myelocyte		
Basophilic myelocyte		
Neutrophilic metamyelocyte		
Eosinophilic metamyelocyte		
Basophilic metamyelocyte		
Preliminary lymphocyte		

Sample Type: Capillary

Exam. Time: 12-08-2015

Microscopic Description: [Empty text area]

Buttons: Apply, OK, Cancel

2. Refer to Table 7-6 for parameter description and operation methods regarding the microscopic examination.

Table 7-6 Microscopic Exam Parameters

Parameter	It means	Operation
Sample Type	Type of sample for microscopic examination.	Click the Sample Type dropdown list box and select the type of sample for microscopic examination.

Parameter	It means	Operation
	<ul style="list-style-type: none"> • Venous blood • Capillary • Cord blood • Blood 	
Exam. Time	Time of microscopic examination.	Click the Exam. Time combo box and select the time and date for the microscopic examination. NOTE The Microscopic exam. time can be no later than the current system time.
Microscopic Description	Description of cells morphology.	Enter the morphology information for WBC, RBC and PLT respectively into the multi-line textbox.

3. Click **OK** to save the settings and close the dialog box.

7.6.9 Communication

You can transmit the current sample data (except the background sample) to the LIS/HIS system in the **Sample Analysis** interface.

1. Click  to unfold all function buttons.
2. Click **Comm..**

7.6.10 Edit Result

NOTE

- You can not edit the results of validated samples.
- You can not edit the results of the background.
- In the CBC mode, only the results of the test parameters are available, the results concerning the percentage of the WBC diff parameters are not available.

You can edit the parameter result of the selected sample as per the following steps.

1. Click  to unfold all function buttons.
2. Click **Edit Result**.

The **Edit Result** dialog box will pop up on the screen as shown in Figure 7-7.

Figure 7-7 Editing Parameter Result

Edit Result								
WBC	<input type="text" value="3.05"/>	10 ⁹ /L	RBC	<input type="text" value="3.73"/>	10 ¹² /L	PLT	<input type="text" value="263"/>	10 ⁹ /L
Neu%	<input type="text" value="0.523"/>		HGB	<input type="text" value="0.7"/>	mmol/L	MPV	<input type="text" value="8.8"/>	fL
Lym%	<input type="text" value="0.369"/>		HCT	<input type="text" value="0.349"/>	L/L	PDW	<input type="text" value="16.0"/>	
Mon%	<input type="text" value="0.070"/>		RDW-CV	<input type="text" value="0.107"/>				
Eos%	<input type="text" value="0.029"/>		RDW-SD	<input type="text" value="43.3"/>	fL			
Bas%	<input type="text" value="0.009"/>							
			<input type="button" value="Apply"/>		<input type="button" value="OK"/>		<input type="button" value="Cancel"/>	

3. Modify the counting results of the corresponding sample parameters.
4. Click **Apply** or **OK** to save the changes.

If the sum of the percentage of the diff parameters is not equal to 100.00% or the WBC value is invalid after modification, the system will prompt in a message box that the entered value is invalid. Please re-enter after confirmation.

If the result of one parameter is modified, then the result of other related parameter(s) will be changed accordingly and the high or low/suspicious flags will also be updated.

NOTE

The result of the parameter that you modified manually will be flagged with an **M**. If any parameter result is then changed due to the one that you modified manually, it will be flagged with an **m**.

7.6.11 Delete

NOTE

- Validated samples are not allowed to be deleted.
- The common user has no access to delete the sample records.

1. Click  to unfold all function buttons.
2. Click **Delete**, and then click **Yes** in the pop-up dialog box to delete the sample.

Figure 7-8 Delete Sample Records

i

Are you sure to delete the current sample record?

8 Result Review

8.1 Introduction

Upon the completion of each sample analysis, the analyzer will automatically save the sample information, result data, flag messages, histograms and scattergrams to the Review Database.

In the **Review** Interface, you can browse the saved sample information, result data, flag messages, histograms and scattergrams, and can search, compare or export the saved sample information.

8.2 Interface Introduction

You can browse, search, compare, print, and export the existing results in the **Review** interface.

Click **Review** to enter the sample review interface. See Figure 8-1.

Figure 8-1 Review

The screenshot displays the Review interface with the following components:

- Navigation Tabs:** Home, Sample Analysis, Review (selected), QC, Reagent Management.
- Function buttons:** Validate, Cancel Validation, Print, Delete, Export, Edit Result, Patient Info., Query.
- Table:**

Sample ID	Mode	Status	WBC	Neu%	Lym%	Mon%	Eos%	Bas%
1	VWB-CBC+DIFF		5.80	67.7	24.0	4.7	2.5	
background	VWB-CBC		61.00					
- Footer:**
 - Sample Count: 0/2 (Sequence Number/Total number of results)
 - 1 / 1 (Current page/Total pages)
 - User: admin
 - 2017/02/23 19:45:43
 - Direction buttons (Left, Right, Home, End)

Interface Description:

- Result list: you can browse detailed sample records.
- Function buttons: you can perform the operations such as comparing or searching the sample results, deleting and viewing the Run Charts, exporting and printing reports.
- Direction button: If you click different direction buttons, the list will move toward the corresponding directions.
 - From left to right, it indicates in sequence: the first column, moving to the left page, moving to the right page, and the last column.
 - From top to bottom, it indicates in sequence: the first page, the previous page, the next page, and the last page.

8.3 Sample List

The review interface shows a list of the analyzed samples, which contains the sample number, status, mode and results of various parameters and other information.

Click a sample or multiple samples in the list area, then you perform operations such as exporting in batch for the selected samples. To cancel the selection, click the selected samples again.

8.4 Functions of the Buttons

8.4.1 Validate

NOTE

After validating, you can not edit the sample/patient information and the result.

After running samples, you can validate the samples as per the following steps.

1. Click **Validate**.

A dialog box will pop up as shown below.

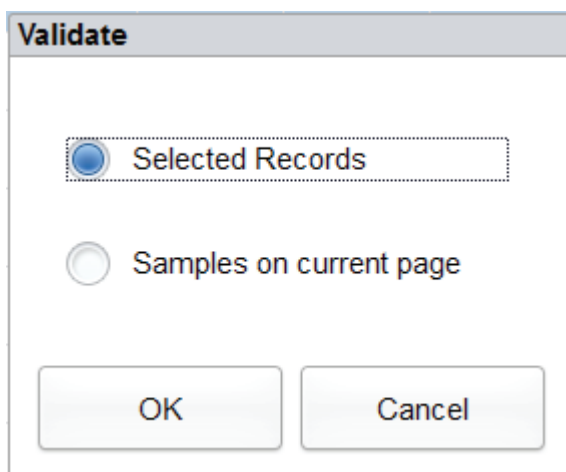

2. Select the sample which needs to be validated.
 - Selected Records: The selected sample results with blue background.
 - Samples on current page: Results of all the samples shown on the current page.
3. Click **OK**.

The system will prompt the validation results as shown in Figure 8-2.

Figure 8-2 Validation Results

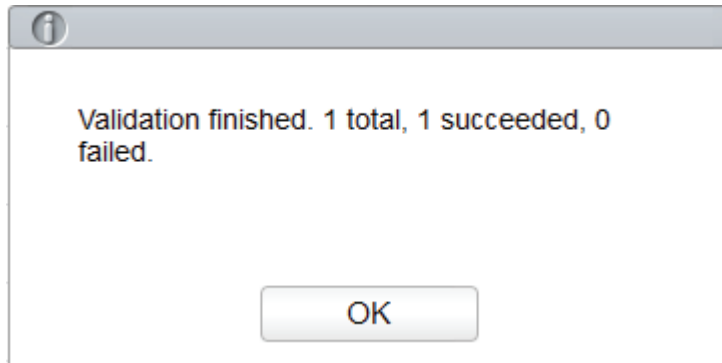

4. Click **OK** to close the message box.

8.4.2 Cancel Validation

NOTE

After canceling the validation, you can edit the sample/patient information and the result.

You can cancel the validation of validated samples. Detailed steps are shown below:

1. Click **Cancel Validation**.

A dialog box will pop up as shown below.

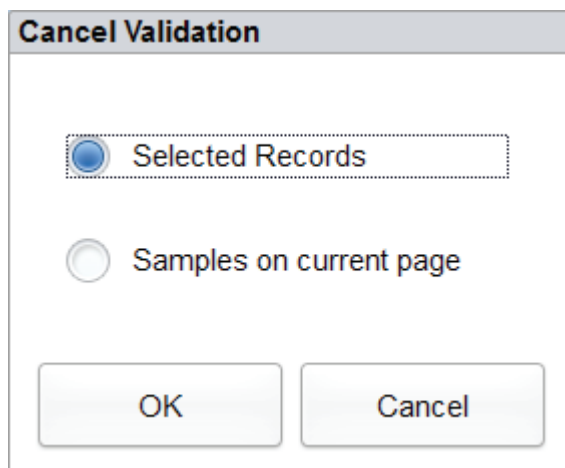

2. Select the sample which needs to be validated.
 - Select **Selected Records**, and the system will cancel the validation for the selected sample results with blue background.
 - Select **Samples on current page**, and the system will cancel the validation for all the samples on the current page.

3. Click **OK**.

The system will prompt the operation results as shown in Figure 8-3.

Figure 8-3 Validation Results

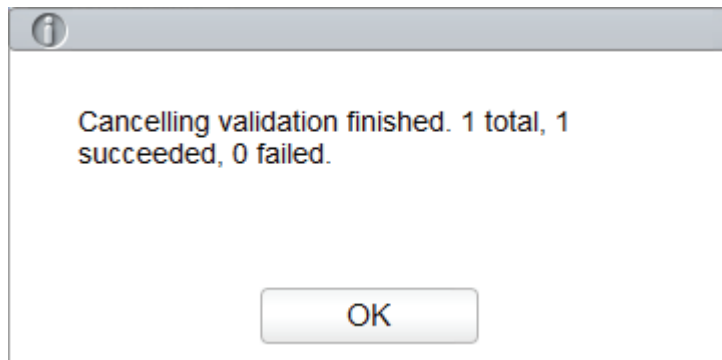

4. Click **OK** to close the message box.

8.4.3 Print

Click **Print** to print the result report of the selected sample.

8.4.4 Delete

NOTE

- Validated samples are not allowed to be deleted.
 - The common user has no access to delete the sample records.
-

1. Select one or several sample records to be deleted.
2. Click **Delete**.

A prompt box will pop up on the screen as shown below.

Figure 8-4 Delete Sample Records

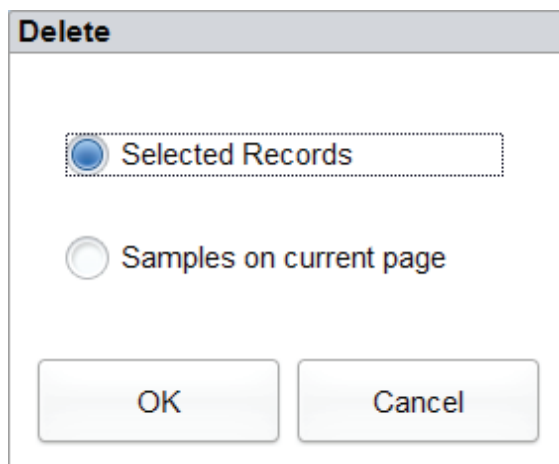

3. Select one or several sample records to be deleted according to the actual situation.
 - Selected Records: The selected sample results with blue background.
 - Samples on current page: Results of all the samples shown on the current page.
4. Click **OK** to delete the selected record(s).

8.4.5 Export

The operator can export the sample data to the USB flash disk for backup. There are two ways of exporting the sample data: exporting selected records and exporting records of specified dates.

- Export Selected Records
 - a. Insert a USB flash disk in the USB interface on the analyzer.
 - b. Select records to be backed up, and click **Export**.

As shown in the following figure, the export range of the system is **Selected Records** by default.

Figure 8-5 Export Selected Records

Export

Select Export Range

Selected Records

Records of the Specified Dates

2018/10/17 - 2018/10/17

Select Export Content

Patient Info.

Sample Info.

Graphs and Flags

Custom Para.

RUO Parameters

OK Cancel

- c. Select the content to be exported according to the actual demand.
Content available for export includes: **Patient Info.**, **Sample Info.**, **Graphs and Flags**, **Custom Para.**, **RUO Parameters**.

- d. Click **OK**.
- e. Select the data export path in the popup dialog box, enter the backup file name.
The file will be exported to the root directory of the USB flash disk (**/udisk/sda1**) and named in the format of **SampleInfo_yyyyMMdd_hhmmss.csv**. Among which, *yyyymmdd_hhmmss* means data export year, month, date, hour, minute, and second.

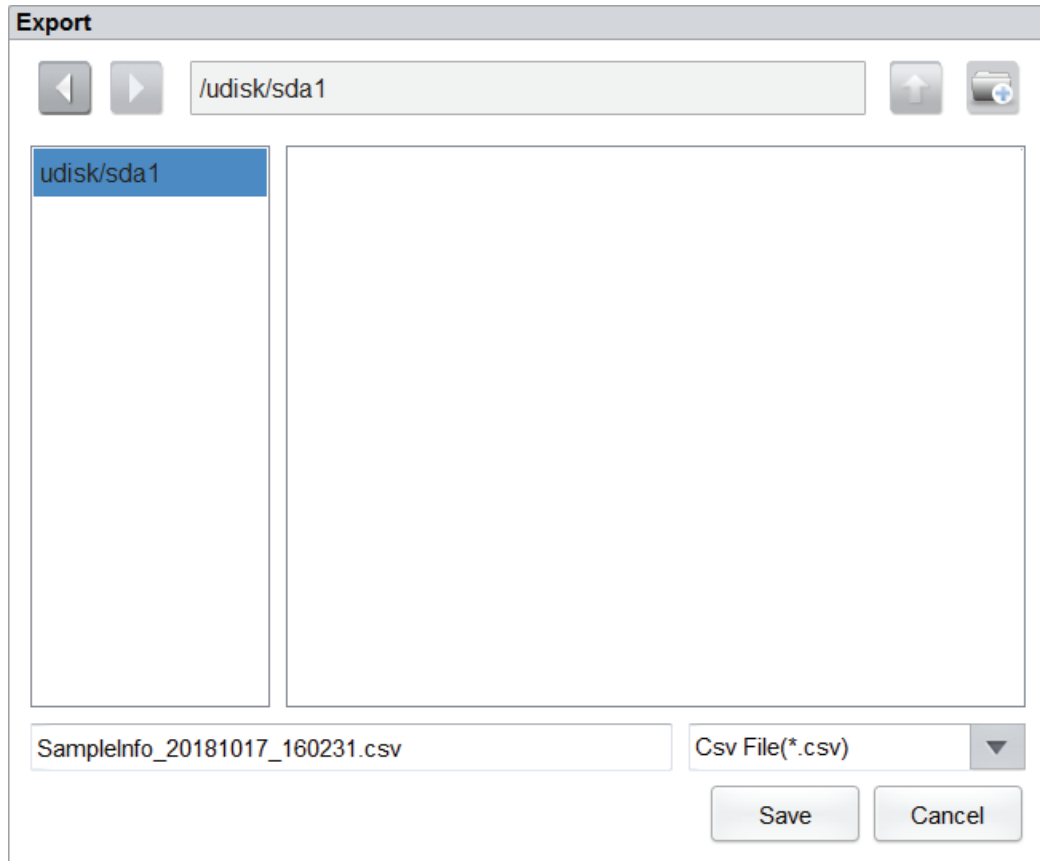

- f. Click **Save**.
The system pops up a dialog box as shown below to indicate that the data export is successful.

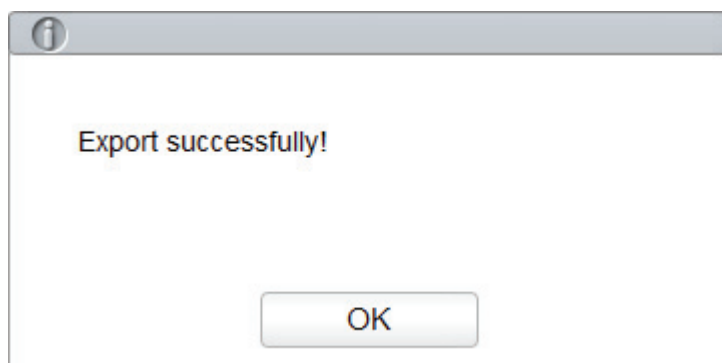

- Export Records of the Specified Dates
 - a. Insert a USB flash disk in the USB interface on the analyzer.
 - b. Click **Export**.
 - c. Select **Records of the Specified Dates** and set the run date range of sample in the two date textboxes. See Figure 8-6.

Figure 8-6 Export Records of the Specified Dates

Export

Select Export Range

Selected Records

Records of the Specified Dates

2018/10/17 - 2018/10/17

Select Export Content

Patient Info.

Sample Info.

Graphs and Flags

Custom Para.

RUO Parameters

OK Cancel

- d. Select the content to be exported according to the actual demand.
Content available for export includes: **Patient Info.**, **Sample Info.**, **Graphs and Flags**, **Custom Para.**, **RUO Parameters**.
- e. Click **OK**.
- f. Select the data export path in the popup dialog box, enter the backup file name.
The file will be exported to the root directory of the USB flash disk (**/udisk/sda1**) and named in the format of **SampleInfo_yyyyMMdd_hhmmss.csv**. Among which, **yyyymmdd_hhmmss** means data export year, month, date, hour, minute, and second.
- g. Click **Save**.
The system pops up a dialog box as shown below to indicate that the data export is successful.

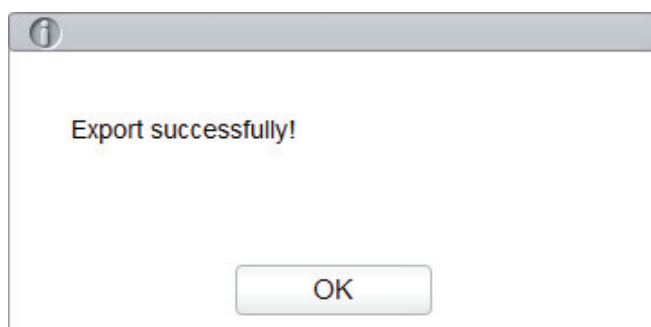

8.4.6 Edit Result

NOTE

- You can not edit the results of validated samples.
- Background result cannot be edited!
- In the **CBC** mode, only the results of the test parameters are available, the results concerning the percentage of the WBC diff parameters are not available.

You can edit the parameter result of the selected sample as per the following steps.

1. Select a row of record from the result list and click the **Edit Result** button.

The **Edit Result** dialog box will pop up on the screen as shown in Figure 8-7.

Figure 8-7 Editing Parameter Result

Edit Result								
WBC	<input type="text" value="3.05"/>	10 ⁹ /L	RBC	<input type="text" value="3.73"/>	10 ¹² /L	PLT	<input type="text" value="263"/>	10 ⁹ /L
Neu%	<input type="text" value="0.523"/>		HGB	<input type="text" value="0.7"/>	mmol/L	MPV	<input type="text" value="8.8"/>	fL
Lym%	<input type="text" value="0.369"/>		HCT	<input type="text" value="0.349"/>	L/L	PDW	<input type="text" value="16.0"/>	
Mon%	<input type="text" value="0.070"/>		RDW-CV	<input type="text" value="0.107"/>				
Eos%	<input type="text" value="0.029"/>		RDW-SD	<input type="text" value="43.3"/>	fL			
Bas%	<input type="text" value="0.009"/>							
			<input type="button" value="Apply"/> <input type="button" value="OK"/> <input type="button" value="Cancel"/>					

2. Modify the counting results of the corresponding sample parameters.
3. Click **Apply** or **OK** to save the changes.

If the sum of the percentage of the diff parameters is not equal to 100.00% or the WBC value is invalid after modification, the system will prompt in a message box that the entered value is invalid. Please re-enter after confirmation.

If the result of one parameter is modified, then the result of other related parameter(s) will be changed accordingly and the high or low/suspicious flags will also be updated.

8.4.7 Patient Info.

You can browse and edit sample/patient information after the sample analysis is completed. Detailed steps are shown below:

1. Click **Patient Info.**

The interface as shown in Figure 8-8 will pop up on the screen.



Figure 8-8 Patient Info.







Patient Info.		
First Name <input type="text"/>	Last Name <input type="text"/>	Sample ID <input type="text" value="7"/>
Patient Type <input type="text" value=""/> ▼	Sample Type <input type="text" value=""/> ▼	Department <input type="text" value=""/> ▼
Med Rec. No. <input type="text"/>	Area <input type="text" value=""/> ▼	Bed No. <input type="text" value=""/> ▼
Gender <input type="text" value=""/> ▼	Birthday <input type="text" value="- -"/> ▼	Age <input type="text" value=""/> Year ▼
Ref. Group <input type="text" value="General"/> ▼	Sampling Time <input type="text" value="- -"/> ▼	Delivery Time <input type="text" value="- -"/> ▼
Submitter <input type="text" value=""/> ▼	Operator <input type="text" value="admin"/>	Run Time <input type="text" value="08-14-2015 18:06"/> ▼
Mode <input type="text" value="VWB-CBC+DIFF"/>	Approver <input type="text" value=""/>	Report Time <input type="text" value="- -"/> ▼
Diagnosis <input type="text"/>		
Remarks <input type="text"/>		
<input type="button" value="Apply"/> <input type="button" value="OK"/> <input type="button" value="Cancel"/>		

2. Enter patient information with reference to the parameter description in Table 8-1.

Table 8-1 Parameter Description

Parameter	It means	Operation
Sample ID	Number of the selected sample.	It will be displayed automatically, and you can modify it manually.
First Name	First name of patient.	Input in the textbox directly.
Last Name	Last name of patient.	Input in the textbox directly.
Patient Type	Type of patient. Values: <ul style="list-style-type: none"> • Inpatient • Physical Exam • STAT • Outpatient 	Select from the dropdown list.
Sample Type	Type of selected sample. <ul style="list-style-type: none"> • Venous blood • Capillary • Cord blood • Blood 	Select from the dropdown list.

Parameter	It means	Operation
Med Rec. No.	Med Rec. No. of patient.	Input in the textbox directly.
Gender	Gender of patient. Values: <ul style="list-style-type: none"> • (Null) • Male • Female • Not defined 	Select from the dropdown list.
Birthday	Birthday of a patient.	Select from the date control. <ul style="list-style-type: none"> • The input sequence of the controls is the same with the date format on the top right corner of the dialog box. For example, if the data format is yyyy/MM/dd, you should input the data in the sequence of year, month, and date. • Click  or  to select a date and time or enter the information in the textbox directly. • Click  to clear the current data and re-enter the information.
Age	Age of a patient.	Select the unit of age from the dropdown list (Year, Month, Week, Day or Hour) and enter the age of the patient in the textbox before the age unit.
Ref. Group	Reference group of the sample under analysis. The result is judged according to the reference range of the reference group and the result beyond the normal range will be flagged.	Select from the dropdown list. NOTE <ul style="list-style-type: none"> • If the Automatically match the customized reference group according to age and gender is set, gender and age of a patient will automatically match the reference group according to the corresponding relationship (No matter the reference group is selected or not). • Refer to 5.4.3 Ref. Range for the setting of the reference group and range.
Department	Department receiving the patient.	Select from the dropdown list.
Area	Ward area of patient.	Input in the textbox directly.
Bed No.	Bed No. of inpatient.	Input in the textbox directly. NOTE The bed No. is required to be filled only for inpatients.

Parameter	It means	Operation
Sampling Time	Date and time when the sample is collected.	<p>Click the date control for the settings.</p> <ul style="list-style-type: none"> The input sequence of the controls is the same with the date format on the top right corner of the dialog box. For example, if the data format is yyyy/MM/dd HH:mm, you should input the data in the sequence of year, month, date, hour, and minute. Click  or  to select a date and time or enter the information in the textbox directly. Click  to clear the current data and re-enter the information. <p>NOTE</p> <p>The sampling time can be no later than the current system time.</p>
Submitter	Personnel submitting the sample.	Select from the dropdown list or input directly.
Mode	Counting mode of the selected sample. The format is <i>blood sample mode-measurement mode</i> .	You do not need to enter it and it will be displayed automatically.
Delivery Time	Date and time when the sample is delivered.	<p>Click the date control for the settings.</p> <ul style="list-style-type: none"> The input sequence of the controls is the same with the date format on the top right corner of the dialog box. For example, if the data format is yyyy/MM/dd HH:mm, you should input the data in the sequence of year, month, date, hour, and minute. Click  or  to select a date and time or enter the information in the textbox directly. Click  to clear the current data and re-enter the information. <p>NOTE</p> <p>The delivery time can be no later than the current system time and cannot be earlier than the sampling time.</p>
Operator	Personnel running the sample.	You do not need to enter it and it will be displayed automatically.
Run Time	Time when the sample is run.	You do not need to enter it and it will be displayed automatically.
Approver	Personnel validating the sample.	This parameter will be automatically displayed after the sample is validated.

Parameter	It means	Operation
Report Time	The date and time when the report is printed for the first time.	This parameter will be automatically displayed after the report is printed.
Diagnosis	Suspected diagnosis information.	Input in the textbox directly.
Remarks	Clarifications or notes.	Input in the textbox directly.

3. Click **Apply** or **OK** to save the configuration.

8.4.8 Query

You can view the test results of a patient within a certain test date range by entering the query conditions. The procedures are shown as below:

1. Click the **Query** button to enter the multi-conditional query dialog box as shown below.

Figure 8-9 Query Conditions

The screenshot shows a dialog box titled "Query" with the following fields and options:

- Sample ID**: A text input field.
- First Name**: A text input field.
- Last Name**: A text input field.
- Med Rec. No.**: A text input field.
- Para.**: A dropdown menu showing "WBC", followed by a comparison operator dropdown showing ">=", and an empty text input field.
- Run Date**: Two date dropdown menus showing "2016/11/16" separated by a hyphen.
- Sample status**: Three radio button options: "Not Validated" (selected), "Not Printed", and "Not Transmitted".
- Auto select**: A checked checkbox.
- Buttons**: "All Samples", "OK", and "Cancel".

2. Determine the query conditions as needed.
For the specific parameter description, see Table 8-2.

Table 8-2 Parameter Description of Query Conditions

Parameter	It means	Operation Description
Sample ID	Sample ID to be queried.	Input in the textbox directly.
Name	Name of patient.	Input in the textbox directly.
Med Rec. No.	Med Rec. No. of patient.	Input in the textbox directly.
Para.	Parameter and its range to be queried.	Select a parameter from the first dropdown list, and a comparison symbol (\geq , $>$, \leq , $<$, $=$) from the second dropdown list, then input a value in the textbox. For example, if you select WBC and $>$, then input 3 in the textbox. The sample results which RBC value is greater than $3.0 \times 10^{12}/L$ will be queried and displayed.
Run Date	Test date range of sample.	Select the starting and ending dates of the sample test in the two data controls successively.
Sample status	Status of validation, printing or communication of the sample. <ul style="list-style-type: none"> • Not Validated • Not Printed • Not Transmitted 	Please choose according to the actual situation. The default value is Not Validated .

NOTE

- **Auto select** checked by default indicates that the query result is being selected (with a blue background color). If it's unchecked, the query result will remain on a white background color.
- Click **All Samples** to close the current window, display all the samples again and restore all the filter conditions to the default values.

3. Click **OK**.

The system will display all the query results which meet the conditions.

8.4.9 Graph

In the **Review** interface, you can click **Graph** to browse the selected sample graph results, parameter results and flag messages. The procedures are shown as below:

1. Select a result to review in graph interface.
2. Click  to unfold all function buttons.
3. Click **Graph** to enter the graph interface of the selected sample.

In the **Graph** interface, you can view sample information such as parameter results, graph results and flag messages. In addition, you can also print the analysis report as. See Figure 8-10.

Figure 8-10 Graphs Review

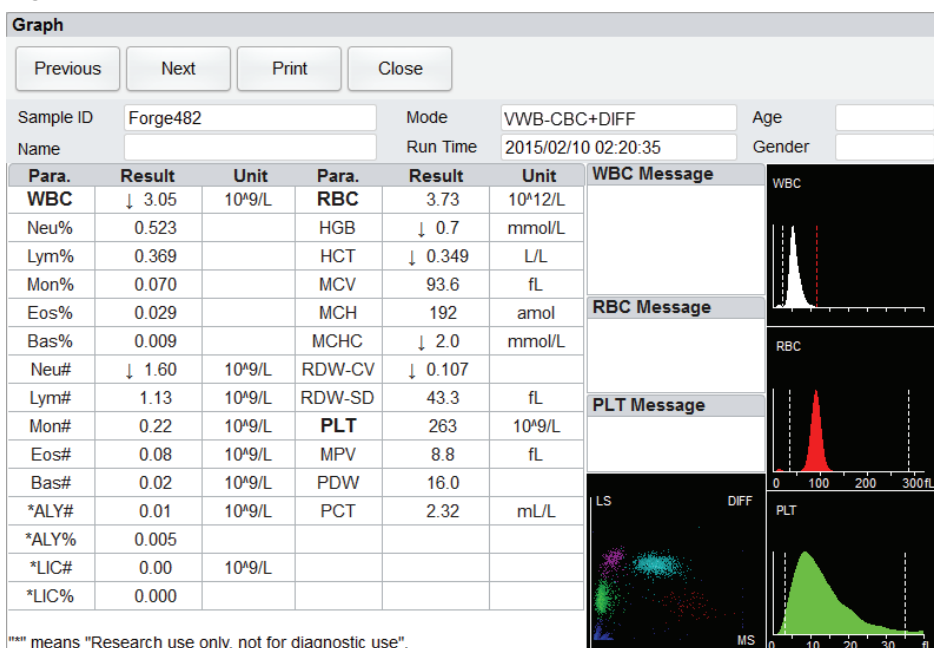

8.4.10 Microscopic Exam Parameters

You can perform the microscopic examination settings as per the following steps.

1. Click **Microscopic Exam Para.**

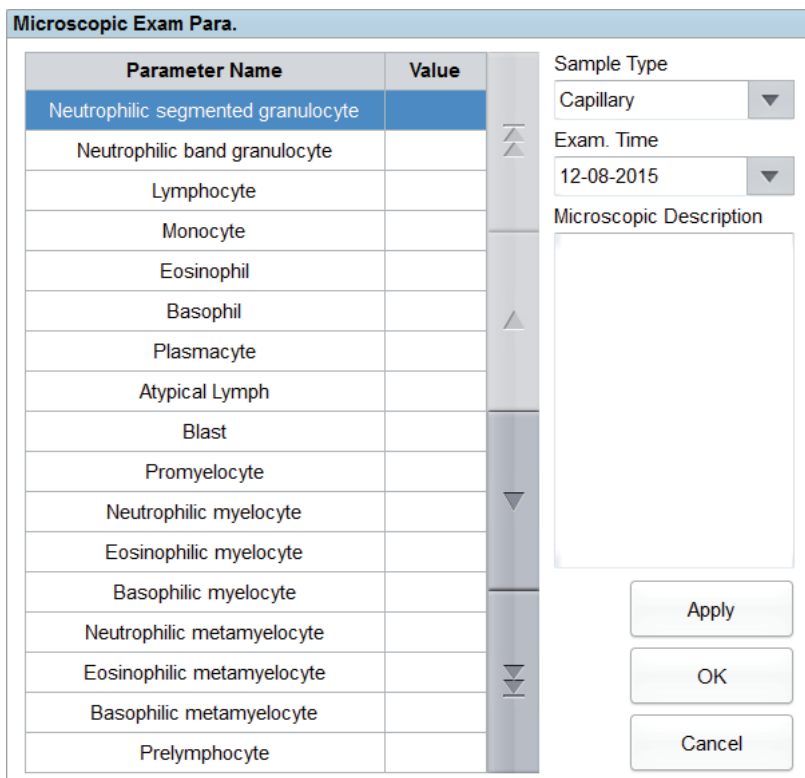

The microscopic examination parameters interface as shown in Figure 8-11 will pop up on the screen.

Figure 8-11 Adding a New Microscopic Exam Parameter



- Set the microscopic examination parameters by referring to Table 8-3.

Table 8-3 Microscopic Exam Parameters

Parameter	It means	Operation
Sample Type	Type of sample for microscopic examination. <ul style="list-style-type: none"> • Venous blood • Capillary • Cord blood • Blood 	Click the Sample Type dropdown list box and select the type of sample for microscopic examination.
Exam. Time	Time of microscopic examination.	Click the date control for the settings. <ul style="list-style-type: none"> • The input sequence of the controls is year, month, date, hour, and minute. • Click  or  to select the date or click the textbox to enter them directly. • Click  to clear the current data and re-enter the information. <p>NOTE The Microscopic exam. time can be no later than the current system time.</p>
Microscopic Description	Description of cells morphology.	Enter the morphology information for cells into the multi-line textbox.

8.4.11 Customized Parameters

You can browse and edit the customized parameters results of the selected sample in the **Review** interface. The procedures are shown as below:

- Select one sample.
- Click  to unfold all function buttons.
- Click **Custom Para.** to enter the customized parameters setting interface as shown in Figure 8-12.

Figure 8-12 Customized Parameters

Custom Para.				
Para.	Flag	Value	Unit	Range
Blood Type				
RH Blood Group				
ESR				
C-reactive Protein				
Reticulocyte				

4. Click the cell corresponding to its **Value** column of the parameter, and enter the value.
- If the unit and reference range of parameters have been set in the **Setup > Parameter > Custom Para.** interface, the corresponding unit and range (lower limit~upper limit) will be displayed in this tab. When both the value and range of parameters are numbers, and the number is out of the reference range, the relevant mark ↑ or ↓ will be displayed in the **Flag** column.

Please refer to **5.4.6 Customized Parameters** for customized parameters settings.

8.4.12 Communication

You can transmit the selected sample data, the data in the current page or the data within the specified date range to the LIS/HIS system in the **Review** interface.

- Selected Records
 - a. Select one or several sample data to be communicated in the result list.
 - b. Click  to unfold all function buttons.
 - c. Click **Comm.**

A dialog box will pop up as shown in Figure 8-13. The default option is **Selected Records**.

Figure 8-13 Communication for Selected Data

The screenshot shows a dialog box titled "Comm." with three radio button options: "Selected Records" (which is selected), "Samples on current page", and "Records of the Specified Dates". Below the options are two date dropdown menus, both showing "2017/02/23". At the bottom are "OK" and "Cancel" buttons.

d. Click **OK**.

After the data is transmitted to LIS/HIS, a message box as shown below will pop up.

The screenshot shows a message box with an information icon in the top left corner. The text inside reads: "A total of 1 records were transmitted, 1 successful, and 0 failed." There is an "OK" button at the bottom center.

e. Click **OK** to close the message box.

- Samples on current page

a. Click  to unfold all function buttons.

b. Click **Comm.**.

Select **Samples on current page**. See Figure 8-14.

Figure 8-14 Communication for Data on Current Page

The screenshot shows a dialog box titled "Comm." with three radio button options: "Selected Records", "Samples on current page" (which is selected and highlighted with a red box), and "Records of the Specified Dates". Below the options are two date dropdown menus, both showing "2017/02/23". At the bottom are "OK" and "Cancel" buttons.

- c. Click **OK**.

After the data is transmitted to LIS/HIS, a message box as shown below will pop up.

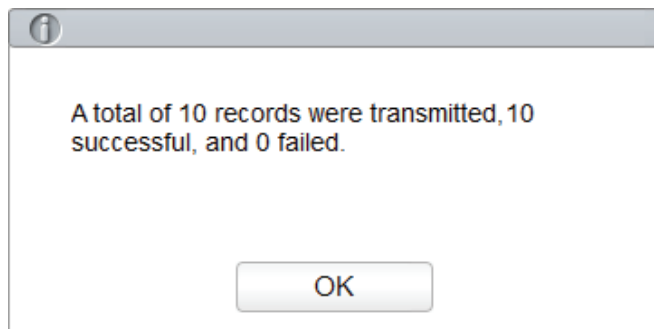

- d. Click **OK** to close the message box.

● Records of the Specified Dates

- a. Click  to unfold all function buttons.

- b. Click **Comm..**

- c. Select **Records of the Specified Dates**, and set the starting and ending dates of data to be communicated.

See Figure 8-15.

Figure 8-15 Communication for Data on Specified Dates

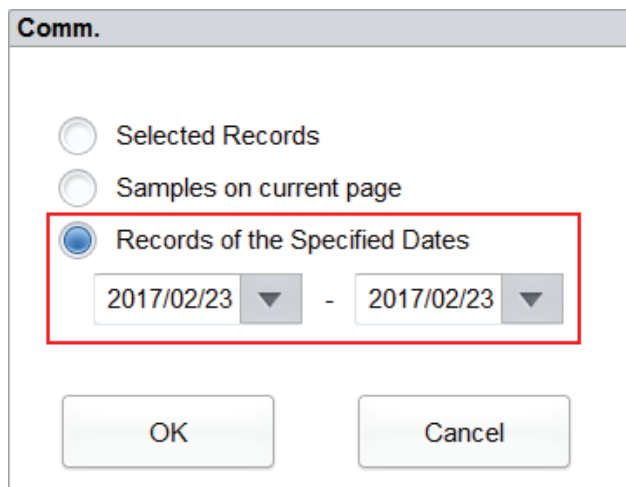

- d. Click **OK**.

After the data is transmitted to LIS/HIS, a message box as shown below will pop up.

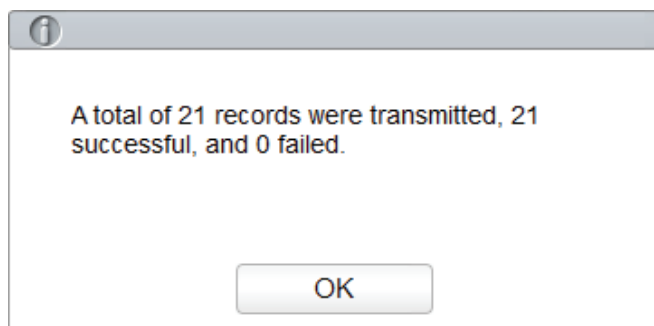

- e. Click **OK** to close the message box.

8.4.13 Run Chart

Operators can check and review run charts of sample parameter results in the database. There are three view modes: selected samples, samples on current page and samples on specified run dates.

- View the run chart of the selected sample (default)
 - a. Check no fewer than three sample records.
 - b. Click  to unfold all function buttons.
 - c. Click **Run Chart**.

The system pops up a dialog box as shown below.

Figure 8-16 Viewing the Run Chart of the Selected Sample

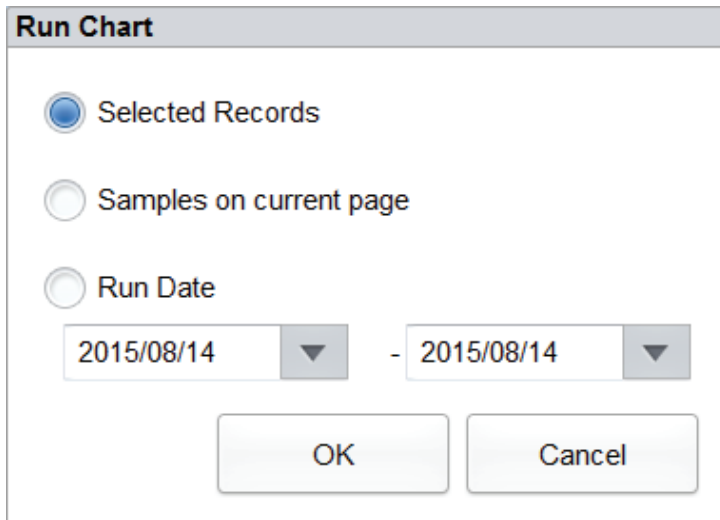

- d. Click **OK**.

The screen will show the parameter result run chart of the selected sample. See Figure 8-17.

Figure 8-17 Run Chart

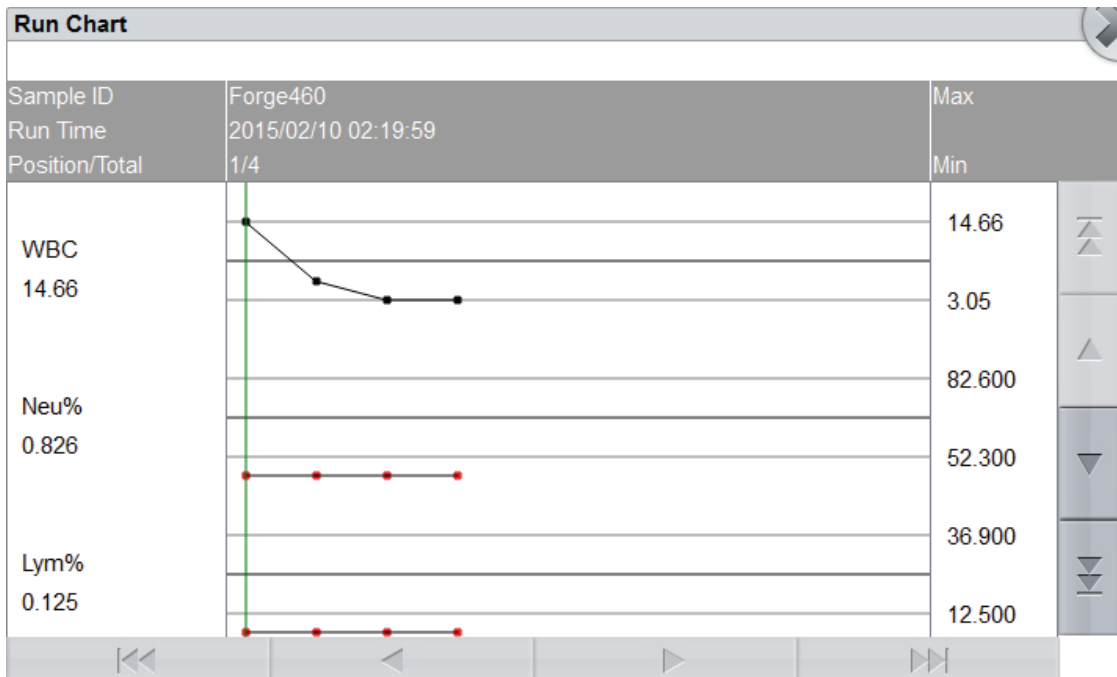

- View the run chart of samples on current page
 - a. Click  on the current page to unfold all function buttons.
 - b. Click the **Run Chart** button and select **Samples on current page** in the pop-up dialog box. See Figure 8-18.

Figure 8-18 Viewing the Run Chart of Samples on the Current Page



The dialog box titled "Run Chart" contains three radio button options: "Selected Records", "Samples on current page", and "Run Date". The "Samples on current page" option is selected and highlighted with a red dashed box. Below the radio buttons are two date input fields, both containing "2015/07/23", separated by a hyphen. At the bottom are "OK" and "Cancel" buttons.

- c. Click **OK**.

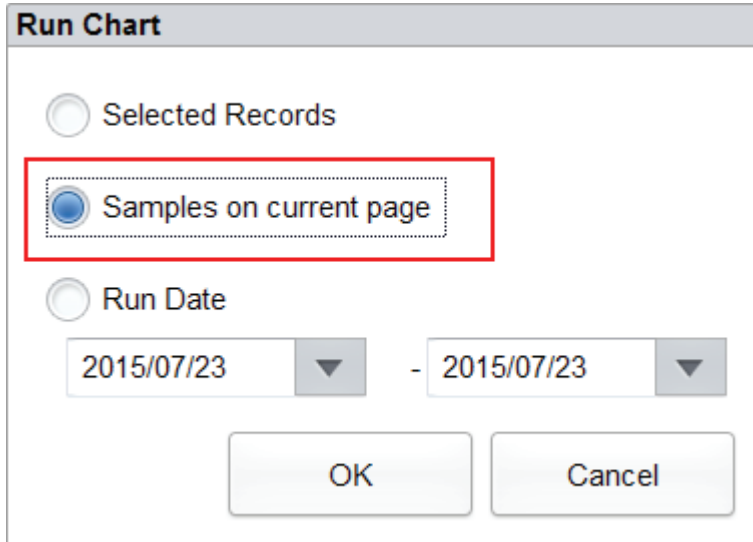
The screen will show the parameter result run chart of the selected sample.
- View the run chart of samples on specified run dates
 - a. Click  to unfold all function buttons.
 - b. Click the **Run Chart** button, and select **Run Date** in the pop-up dialog box. See Figure 8-19.



Figure 8-19 Viewing the Run Chart of Samples on Specified Run Dates

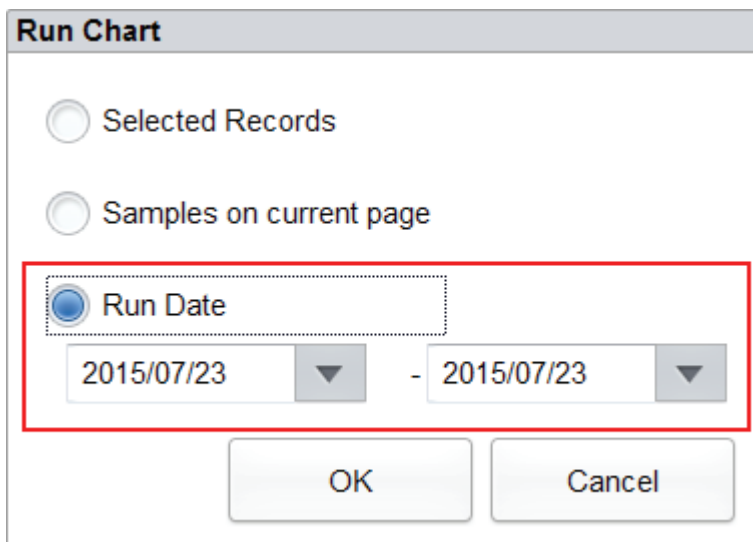

The dialog box titled "Run Chart" contains three radio button options: "Selected Records", "Samples on current page", and "Run Date". The "Run Date" option is selected and highlighted with a red dashed box. Below the radio buttons are two date input fields, both containing "2015/07/23", separated by a hyphen. At the bottom are "OK" and "Cancel" buttons.

- c. Click the date edit box, set a date range in the pop-up dialog box, then click **OK**.

The input sequence of the controls is the same with the date format on the top right corner of the dialog box. For example, if the data format is **yyyy/MM/dd**, you should input the data in the sequence of year, month, and date.

Click  or  to select a date and time or enter the information in the textbox directly.

Click  to clear the current data and re-enter the information.

- d. Click **OK**.

The screen will show the parameter result run chart of the selected sample.

8.4.14 CV

You can check the repeatability of the selected sample record.

NOTE

- At least 3 records should be selected to calculate the repeatability.
- There is no restriction to the sample records selected to calculate the repeatability as long as they are in the review list.
- If the selected sample records contain records in CBC Mode, only the repeatability of CBC parameters will be calculated and the repeatability of WBC DIFF parameters and the DIFF absolute deviation will not be calculated.

Specific steps are shown below:

1. Select the sample records used for calculating the repeatability.
2. Click  on the current page to unfold all function buttons.
3. Click **CV**.

The analyzer starts calculating the repeatability, and then pops up the result message box as shown in Figure 8-20.

Figure 8-20 Calculation Results

Para.	Mean	SD	CV(%)
WBC	4.88	0.07	1.4
Neu%	50.4	1.4	2.7
Lym%	40.1	0.7	1.8
Mon%	5.0	0.8	15.1
Eos%	3.3	0.4	12.4
Bas%	1.1	0.1	11.4
Neu#	2.47	0.08	3.3
Lym#	1.97	0.03	1.6
Mon#	0.24	0.04	15.6
Eos#	0.16	0.02	13.5
Bas#	0.04	0.01	12.2
*ALY#	0.07	0.01	21.2
*ALY%	1.3	0.3	23.2
*LIC#	0.00	0.00	0.0
*LIC%	0.0	0.0	0.0

- Click **DIFF Deviation**.

You can check the absolute deviation of the 5 WBC-related parameters of percent-style.

Sample ID	Neu%	Lym%	Mon%	Eos%	Bas%
5	0.5	-0.9	0.9	-0.4	-0.1
6	-0.4	0.4	-0.1	0.1	0.1
7	-0.2	-0.0	-0.4	0.6	0.1
8	2.5	-0.8	-1.2	-0.5	0.0

- After browsing, click  to return to the CV calculation results dialog box.
- Click **Close** to exit the CV calculation screen.

8.4.15 Research Results

NOTE

- The specific values of the parameter results that are beyond the display range or without data collected cannot be provided.
- The editing of the parameter results will not affect the display of parameters in the **Research Results** interface.
- The content of this interface can only be viewed and used for research; it cannot be edited.

You can view the detailed results of each parameter in the **Research Results** interface, and can also transfer the research results of the selected sample to the LIS system. The procedures are shown as below:

1. Select a result.
2. Click Research Results.

The interface as shown below will pop up. See Figure 8-21.

Figure 8-21 Research Results

Research Results					
Para.	Result	Unit	Para.	Result	Unit
WBC	?↑ 12.19	10 ⁹ /L	RBC	? 4.18	10 ¹² /L
Neu%	0.0	%	HGB	127	g/L
Lym%	86.9	%	HCT	? 38.2	%
Mon%	1.5	%	MCV	? 91.2	fL
Eos%	1.1	%	MCH	? 30.5	pg
Bas%	10.5	%	MCHC	? 334	g/L
Neu#	0.00	10 ⁹ /L	RDW-CV	?↑ 38.7	%
Lym#	10.60	10 ⁹ /L	RDW-SD	?↑ 136.8	fL
Mon#	0.18	10 ⁹ /L	PLT	?↑ 497	10 ⁹ /L
Eos#	0.13	10 ⁹ /L	MPV	? 7.4	fL
Bas#	1.28	10 ⁹ /L	PDW	?↓ 7.8	fL
*ALY#	0.69	10 ⁹ /L	PCT	?↑ 0.367	%
*ALY%	5.7	%			
*LIC#	0.31	10 ⁹ /L			
*LIC%	2.5	%			

*** means "Research use only, not for diagnostic use".

The research results shan't be used as the clinical diagnosis. Please provide a report based on the microscopic examination results.

3. Click **Previous** or **Next**, the screen will display the previous or the next sample research results of the current one.
4. Click **Comm.**, the research results of this sample are transmitted to the LIS system. If the communication is successful, the dialog box as shown below will pop up.

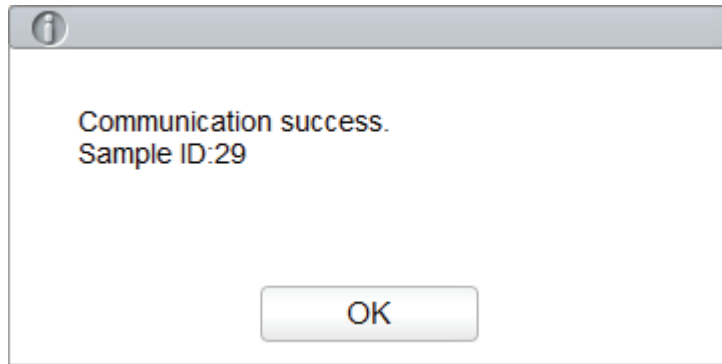

5. Click **Close** to exit the **Research Results** interface.

9 Quality Control

9.1 Introduction

Quality Control (QC) consists of strategies and procedures that measure the precision and stability of the analyzer. The results imply the reliability of the sample results. QC involves measuring materials with known, stable characteristics at frequent intervals.

Analysis of the results with statistical methods allows the inference that sample results are reliable. Dymind recommends running the QC program on a daily basis with low, normal and high level controls. A new lot of controls should be analyzed in parallel with the current lot prior to their Exp. dates. This may be accomplished by running the new lot of controls twice a day for five days using any empty QC file.

NOTE

- You should only use the Dymind-specified controls and reagents. Store and use the controls and reagents by following the instructions for use of the controls and reagents.
 - Controls beyond their Exp. date shall not be used. Controls (similar to standard blood samples) must be well mixed before use.
 - General users only have the access for browsing and executing the QC analysis other than editing.
-

9.2 L-J Quality Control

9.2.1 QC Principle

In the L-J quality control, quality control can be applied to 23 parameters. You can perform QC on relevant parameters according to the configured QC mode. After the QC settings, you can perform QC analysis on the corresponding parameters according to the set QC mode. Each QC file can be assigned 1 Lot number for high, normal and low level controls. Each QC file can store up to 500 QC results. When there are more than 500 QC results, the new QC results will overwrite the oldest results in sequence.

9.2.2 QC Settings



All the samples, controls, calibrators, reagents, wastes and areas in contact with them are potentially biohazardous. Wear proper personal protective equipment (e.g. gloves, lab uniforms, etc.) and follow laboratory safety procedures when handling them and the relevant areas in the laboratory.

NOTE

Only users with administrator-level access can edit the L-J settings.

Before running a new batch of controls, you need to assign a QC file to each batch of controls. You can complete the QC settings by setting QC information in the QC files.

9.2.2.1 Entering QC Information

Administrator can import the QC information by the following three ways.

- Manual Entry
- QR Code
- File

Entering QC Information Manually

Administrator can manually enter the QC information. The procedures are shown as below:

1. Click **QC** to access the **QC** interface.
2. Click **QC Settings** to enter the **QC Settings** interface.

See Figure 9-1.

Figure 9-1 L-J Quality Control

The screenshot displays the L-J Quality Control interface. At the top, there are navigation tabs: Home, Sample Analysis, Review, QC, and Reagent Management. The 'QC' tab is selected. Below the tabs, there is a 'QC Type' dropdown menu set to 'L-J', and several action buttons: Copy, New, Edit, Delete, Clear, and Details. Below these buttons, there are sub-tabs for 'QC Settings', 'QC Analysis', 'QC Graph', and 'QC Table'. The 'QC Settings' sub-tab is active. The main area shows a table with the following columns: File No., Lot No., Level, Exp. Date, QC Mode, QC Sample ID, In use, and Existing / Total. The table is currently empty, and there are vertical scroll bars on the right side.

- Click the **New** button, or select a QC file (**Existing/Total** is **0/500**) without QC counting results and click the **Edit** button.

The interface as shown in Figure 9-2 will pop up on the screen.

Figure 9-2 Entering QC Information

Para.	Target	Limits (#)	Para.	Target	Limits (#)
WBC			MCH		
Neu%			MCHC		
Lym%			RDW-CV		
Mon%			RDW-SD		
Eos%			PLT		
Bas%			MPV		
Neu#			PDW		
Lym#			PCT		
Mon#					
Eos#					
Bas#					
RBC					
HGB					
HCT					
MCV					

File No.

Lot No.

Level

Exp. Date

QC Mode

QC Sample ID

Buttons: Set Limits, Import, Save, Close

You can also select the QC file of which data has been set and then click **Copy**, and edit the content based on the original data.

- Set related information of the controls with reference to Table 9-1.

Table 9-1 QC File Information

Parameter	Parameter Description	Operation Description
File No.	QC file No..	Read only.
Lot No.	Lot number of controls.	Enter into the textbox directly. NOTE The lot No. can not be empty and up to 16 digits can be entered. You can enter characters, numbers, letters and special characters, but no Chinese characters are allowed.
Level	Level of the controls, including 3 levels, i.e. High, Normal and Low.	Select from the dropdown list.
Exp. Date	Exp. date of the controls.	The default Exp. Date is the current system date and needs to be changed to the actual Exp. date of the controls.

Parameter	Parameter Description	Operation Description
QC Mode	QC mode of the controls, including Whole Blood-DIFF and Predilute-CBC+DIFF .	Select from the dropdown list.
QC Sample ID	<p>Number of the QC sample</p> <ul style="list-style-type: none"> Users need to set the number of the controls here if he/she is used to performing the analysis with the controls placed among the daily samples. See section 9.2.3.2 Completing QC Analysis in the Sample Analysis Interface. If the user performs the analysis in the QC Analysis interface, the ID cannot be entered. 	<p>Enter into the textbox directly.</p> <p>NOTE</p> <ul style="list-style-type: none"> Letters, numbers and all characters that can be entered through the keyboard (including special characters) are allowed for the Sample ID. Chinese and other languages (such as Japanese, Korean, etc) are not supported. The length of the entries ranges from 1 to 25. The last character of a sample ID must be numeric, but a string of "0" only is not an acceptable sample ID.
Target	Target of the QC parameter.	Enter the targets in the cell corresponding to the expected QC parameter according to the control target list with the corresponding lot No.
Limits (#)	Limits (#) of the QC parameter.	<p>Enter the limits in the cell corresponding to the expected QC parameter according to the control target list with the corresponding lot No.</p> <p>NOTE</p> <p>You can click Set Limits to set the display form of the limits or the calculation method of the limits among the preset values.</p> <ul style="list-style-type: none"> By SD: the limits displays in form of absolute value. Click 2SD or 3SD to select either double or triple standard deviation to be the limits. By CV: the limits displays in form of percentage. Click 2CV or 3CV to select either double or triple coefficient of variation to be the limits.
In use	<p>Set if you want to specify the QC sample ID in the selected file so that you can run the QC sample in the interface other than the QC interface.</p> <ul style="list-style-type: none"> If it's checked, you can run the sample with the corresponding sample ID in any interface and the system will run the QC analysis for this sample. If it's not checked, you can only run the QC sample in the QC interface. 	It's unchecked by default. Set the parameter according to the actual situation.

Parameter	Parameter Description	Operation Description
Existing/Total	The existing data and total QC results in the current QC file. Up to 500 QC results can be saved for each QC file.	Read only.

5. According to the target list of the corresponding lot No., enter the target and limits into the textboxes of the parameters to be included in the QC run.
6. Click the **Save** button to save all the settings of the QC.

Importing the QC Information by QR code

Administrator can enter the QC information by scanning the QR code.

NOTE

- The 2D barcode scanner will emit LED (Light Emitting Diode) light during operating, which is harmful to human eyes. Please don't directly look at it.
- Please ask the customer service engineer for the QC target table with QR code.
- You need to separately purchase 2D barcode scanner specified by Dymind.

1. Before importing QC information, please connect the 2D barcode scanner to a USB interface on the right side of the analyzer.
2. Click **QC > QC Settings** to enter the **QC Settings** interface.
3. Click the **New** button, or select a QC file (**Existing/Total** is **0/500**) without QC counting results and click the **Edit** or **Copy** button.

The following dialog box will pop up. See Figure 9-3.

Figure 9-3 Importing QC Information

Para.	Target	Limits (#)	Para.	Target	Limits (#)
WBC			MCH		
Neu%			MCHC		
Lym%			RDW-CV		
Mon%			RDW-SD		
Eos%			PLT		
Bas%			MPV		
Neu#			PDW		
Lym#			PCT		
Mon#					
Eos#					
Bas#					
RBC					
HGB					
HCT					
MCV					

File No.

Lot No.

Level

Exp. Date

QC Mode

QC Sample ID

- Click **Import > QR Code**, as shown in the following figure.

Figure 9-4 Import Type Selection

Import

File type

QR Code File

Please scan the QR code.

- Hold the 2D barcode scanner close to the QR code that contains the QC information. The beeping of the 2D barcode scanner indicates the scanning is completed. And following dialog box will pop up, see Figure 9-5.

Figure 9-5 Import Data Scan

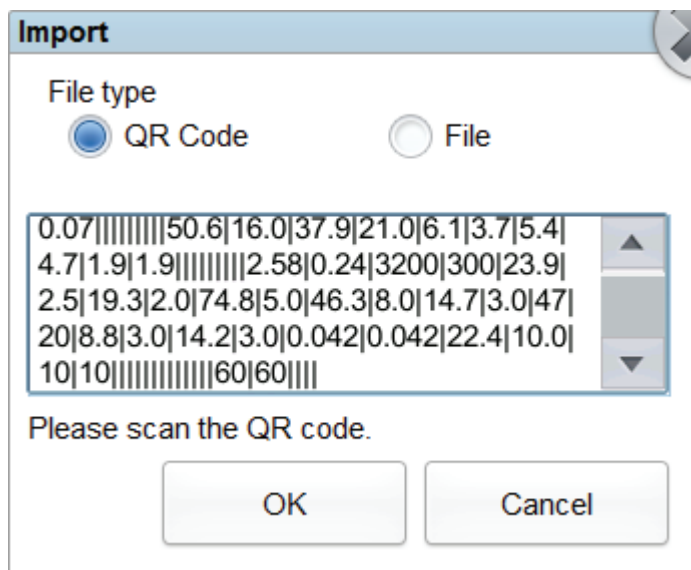

6. Click **OK**.

The following dialog box will pop up. See Figure 9-6.

Figure 9-6 Import Results

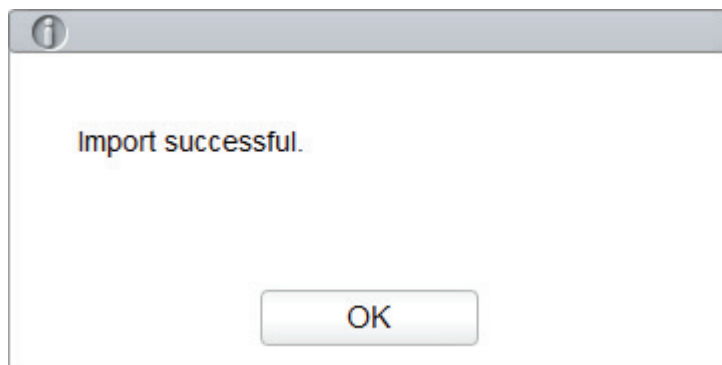

7. Click **OK**.

The interface will display the QC information in QR code. As shown in Figure 9-7.

Figure 9-7 L-J QC Information

Para.	Target	Limits (#)	Para.	Target	Limits (#)
WBC	3.36	0.50	MCH	23.9	2.5
Neu%	50.6	16.0	MCHC	320	30
Lym%	37.9	21.0	RDW-CV	14.7	3.0
Mon%	6.1	3.7	RDW-SD	46.3	8.0
Eos%	5.4	4.7	PLT	47	20
Bas%	1.9	1.9	MPV	8.8	3.0
Neu#	1.70	0.48	PDW	14.2	3.0
Lym#	1.27	0.68	PCT	0.042	0.042
Mon#	0.20	0.13			
Eos#	0.19	0.19			
Bas#	0.07	0.07			
RBC	2.58	0.24			
HGB	6	6			
HCT	19.3	2.0			
MCV	74.8	5.0			

File No.

Lot No.

Level

Exp. Date

QC Mode

QC Sample ID

Editor:

8. After confirm the QC information, click **Save**. The importing of QC information will be finished. Administrator can directly edit relative information on the interface. Please see Table 9-1 for detailed interface parameters.

Importing the QC Information by .qcs File

Administrator can enter the QC information by importing the QC file in **.qcs** format.

NOTE

Please ask the customer service engineer of Dymind for QC file in **.qcs** format.

1. Please connect a USB flash disk that contains QC file in **.qcs** format to a USB interface on the right side of the analyzer before importing QC information.
2. Click **QC > QC Settings** to enter the **QC Settings** interface.
3. Click the **New** button, or select a QC file (**Existing/Total** is **0/500**) without QC counting results and click the **Edit** or **Copy** button.

The following dialog box will pop up. See Figure 9-8.

Figure 9-8 Importing QC Information

Para.	Target	Limits (#)	Para.	Target	Limits (#)
WBC			MCH		
Neu%			MCHC		
Lym%			RDW-CV		
Mon%			RDW-SD		
Eos%			PLT		
Bas%			MPV		
Neu#			PDW		
Lym#			PCT		
Mon#					
Eos#					
Bas#					
RBC					
HGB					
HCT					
MCV					

File No.
7

Lot No.

Level
Normal ▼

Exp. Date
2020/02/13 ▼

QC Mode
Whole Blood-CBC+DIFF ▼

QC Sample ID

Set Limits Import

Save Close

- Click **Import > File**, as shown in the Figure 9-9.

Figure 9-9 Import Type

Import

File type

QR Code File

OK Cancel

- Click **OK**.
The following dialog box will pop up. See Figure 9-10.

Figure 9-10 Import Path

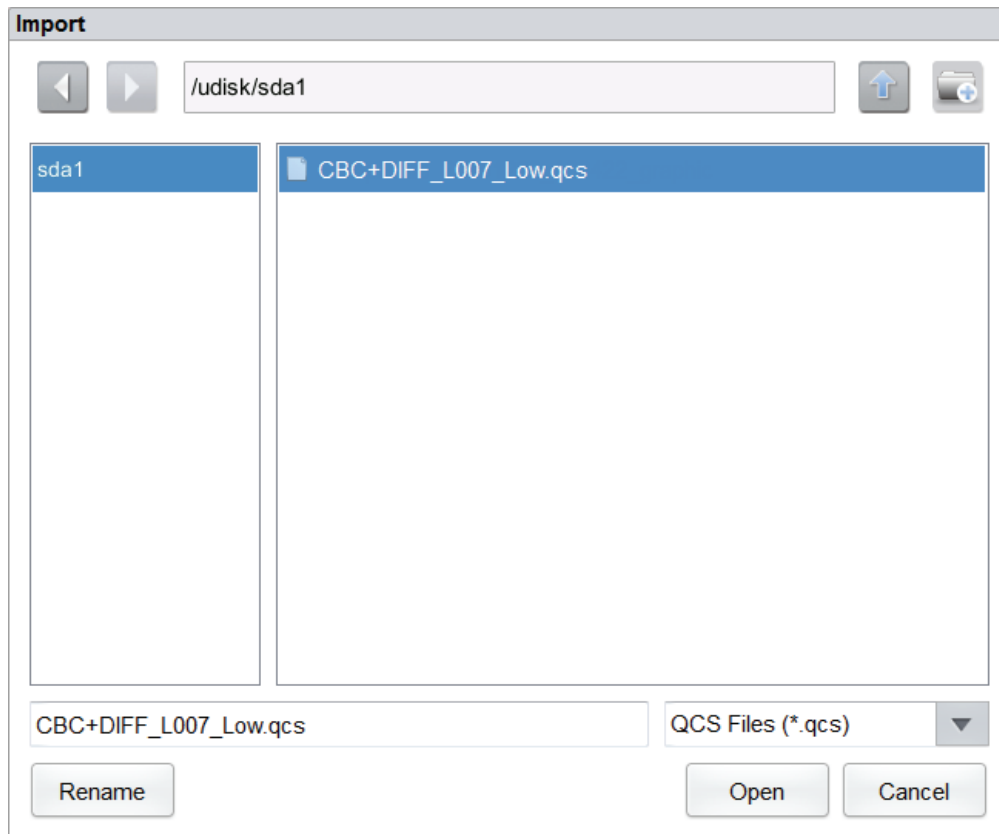

6. Select the QC file to be imported.
7. Click **Open**.

The following dialog box will pop up. See Figure 9-11.

Figure 9-11 Import Results

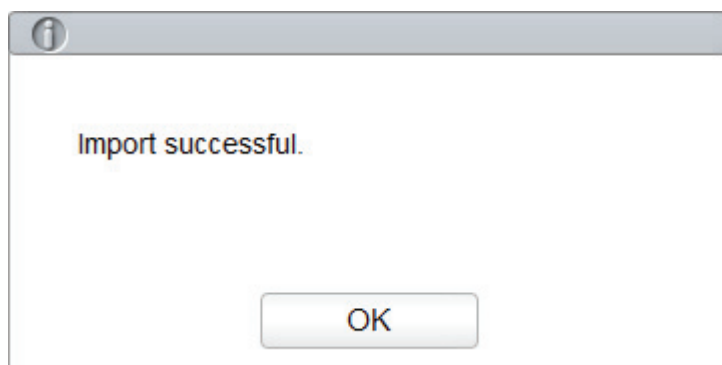

8. Click **OK**.

The screen will display the QC information of current file as shown in Figure 9-12.

Figure 9-12 L-J QC Information

Para.	Target	Limits (#)	Para.	Target	Limits (#)
WBC	3.36	0.50	MCH	23.9	2.5
Neu%	50.6	16.0	MCHC	320	30
Lym%	37.9	21.0	RDW-CV	14.7	3.0
Mon%	6.1	3.7	RDW-SD	46.3	8.0
Eos%	5.4	4.7	PLT	47	20
Bas%	1.9	1.9	MPV	8.8	3.0
Neu#	1.70	0.48	PDW	14.2	3.0
Lym#	1.27	0.68	PCT	0.042	0.042
Mon#	0.20	0.13			
Eos#	0.19	0.19			
Bas#	0.07	0.07			
RBC	2.58	0.24			
HGB	6	6			
HCT	19.3	2.0			
MCV	74.8	5.0			

File No.

Lot No.

Level

Exp. Date

QC Mode

QC Sample ID

Editor:

9. After confirm the QC information, click **Save**. The importing of QC information will be finished. Administrator can directly edit relative information on the interface. Please see Table 9-1 for detailed interface parameters.

9.2.2.2 Viewing QC File Details

If you want to view the detailed information of the QC files, please take the following steps:

1. Click **QC** to access the **QC** interface.
2. Click **QC Settings** to enter the **QC Settings** interface.
3. Select the QC file to be viewed, and click **Details**.

The following dialog box will pop up. See Figure 9-13.

Figure 9-13 Details

Para.	Target	Limits (#)	Para.	Target	Limits (#)
WBC	3.36	0.50	MCH	23.9	2.5
Neu%	50.6	16.0	MCHC	320	30
Lym%	37.9	21.0	RDW-CV	14.7	3.0
Mon%	6.1	3.7	RDW-SD	46.3	8.0
Eos%	5.4	4.7	PLT	47	20
Bas%	1.9	1.9	MPV	8.8	3.0
Neu#	1.70	0.48	PDW	14.2	3.0
Lym#	1.27	0.68	PCT	0.042	0.042
Mon#	0.20	0.13			
Eos#	0.19	0.19			
Bas#	0.07	0.07			
RBC	2.58	0.24			
HGB	6	6			
HCT	19.3	2.0			
MCV	74.8	5.0			

File No.

Lot No.

Level

Exp. Date

QC Mode

QC Sample ID

Editor: admin

4. Click **Close** to exit the **Details** interface.

9.2.2.3 Deleting QC File

If you want to delete the QC files which will not be used any more, please take the following steps:

1. Click **QC** to access the **QC** interface.
2. Click **QC Settings** to enter the **QC Settings** interface.
3. Select the QC file to be deleted, and click **Delete**.

The interface pops up a dialog box as shown below.-

Are you sure to delete the QC file (1) and its counting results?

4. Click **Yes**.

All selected QC files together with their QC results will be completely deleted.

9.2.2.4 Clearing QC results

If you want to delete QC results of a specified file, please take the following steps:

1. Click **QC** to access the **QC** interface.
2. Click **QC Settings** to enter the **QC Settings** interface.
3. Select the QC file in which the QC results are expected to be cleared, and click **Clear**.

The interface pops up a dialog box as shown below.

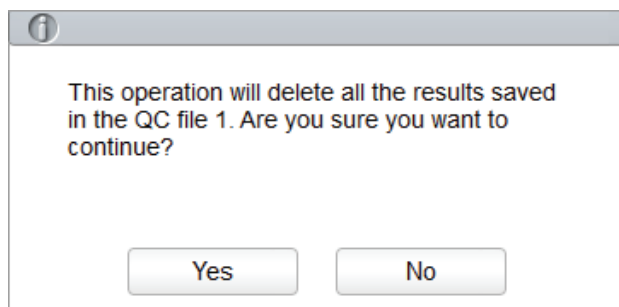

4. Click **Yes**.

QC results in the selected QC file will be deleted. See the picture below. The value in the **Existing/Total** column will be restored to the initial value.

File No.	Lot No.	Level	Exp. Date	QC Mode	QC Sample ID	In use	Existing / Total
1	L001	Normal	2016/12/31	Whole Blood-DIFF		<input type="checkbox"/>	0/500

9.2.3 Quality Control Analysis

After completing the QC settings, you can choose one of the following two modes according to the selected QC mode to run the quality control samples.

- Completing QC analysis in the **QC Analysis** interface
- Completing QC analysis in the **Sample Analysis** interface

9.2.3.1 Completing QC Analysis in the QC Analysis Interface



All the samples, controls, calibrators, reagents, wastes and areas in contact with them are potentially biohazardous. Wear proper personal protective equipment (e.g. gloves, lab uniforms, etc.) and follow laboratory safety procedures when handling them and the relevant areas in the laboratory.

**WARNING**

- The sample probe is sharp and potentially biohazardous. Exercise caution to avoid contact with the probe when working around it.
 - The sample may spill from the unclosed collection tubes and cause biohazard. Exercise caution to the unclosed collection tubes.
 - Collection tubes broken may cause personal injury and/or biohazard. Be sure to place the collection tubes in the right adapter before running, otherwise, the collection tubes may be broken and cause biohazard.
 - Keep your clothes, hairs and hands away from the moving parts to avoid injury.
 - Reagents can be irritating to the eyes, skin, and mucosa. Wear proper personal protective equipment (e.g. gloves, lab uniforms, etc.) and follow laboratory safety procedures when handling them in the laboratory.
 - If the reagent accidentally comes in contact with your skin, wash it off immediately with plenty of water and see a doctor if necessary. Do the same if you accidentally get any of the reagent in your eyes.
-

**CAUTION**

- Running quality controls in presence of errors may lead to incorrect analysis results. If you see the error alarms when running the quality controls, please stop and resume the analysis until the errors are removed.
 - Do not re-use such disposable products as collection tubes, test tubes, capillary tubes, etc.
 - Sample clump may lead to incorrect analysis results. Check if clump exists before running the controls; if it does, handle it as per the related laboratory procedures.
-

NOTE

- You should only use the Dymind-specified controls and reagents. Store and use the controls and reagents as instructed by instructions for use of the controls and reagents. Using other controls may lead to incorrect QC results.
 - Before being used for analysis shake well the controls that have been settled for a while.
 - Be sure to use the Dymind-specified disposable products including vacutainer blood collection tube, vacutainer blood collection tubes with anticoagulant and capillary tubes etc.
-

After completing the QC settings, users can perform the QC analysis in the **QC Analysis** interface. Detailed steps are shown below:

1. Click **QC > QC Analysis** and enter the QC analysis interface as shown in Figure 9-14.

Figure 9-14 QC Analysis

QC Type: L-J | Edit Result | Previous | Next | Print

QC Settings | **QC Analysis** | QC Graph | QC Table

File No.: 1 | QC Mode: Whole Blood-CBC+DIFF | Lot No.: L001
 Existing / Total: 0/500 | Level: Normal | Exp. Date: 2018/02/19
 Editor: admin | QC Sample ID: Run Time: (blank)
 Operator: admin

Para.	Result	Unit	Para.	Result	Unit
WBC			MCH		
Neu%			MCHC		
Lym%			RDW-CV		
Mon%			RDW-SD		
Eos%			PLT		
Bas%			MPV		
Neu#			PDW		
Lym#			PCT		
Mon#					
Eos#					
Bas#					
RBC					
HGB					
HCT					
MCV					

2. Select the QC file No. to be run.

The screen will display the corresponding information and QC parameters.

3. Be sure that the level of the control to be run is the same with the current QC file, and the control to be run is not expired.
4. Prepare the controls according to the set control mode and control instructions.

Predilute the controls with reference to **6.5 Sample Collection and Handling** and get diluted QC samples if the QC mode is **Predilute-CBC+DIFF**.

NOTE

Be sure to evaluate predilute stability based on your laboratory's sample population and sample collection techniques or methods.

5. Shake the prepared control as shown below to mix it well.

Figure 9-15 Mixing the Controls

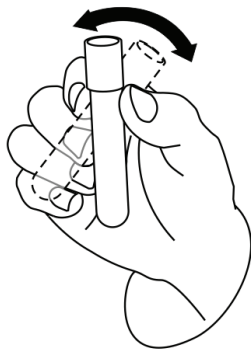

6. In the ready for counting state (namely, the indicator light of the main unit is green), place the controls under the sample probe where the probe can aspirate the well-mixed controls.
7. Press the aspirate key and start running the controls. Upon the completion of the aspiration, you'll hear a beep and you can remove the controls.

When the running of QC analysis is complete, the QC results will be displayed in the current screen (as shown in Figure 9-16) and saved in the QC file automatically.

Figure 9-16 QC Analysis Results

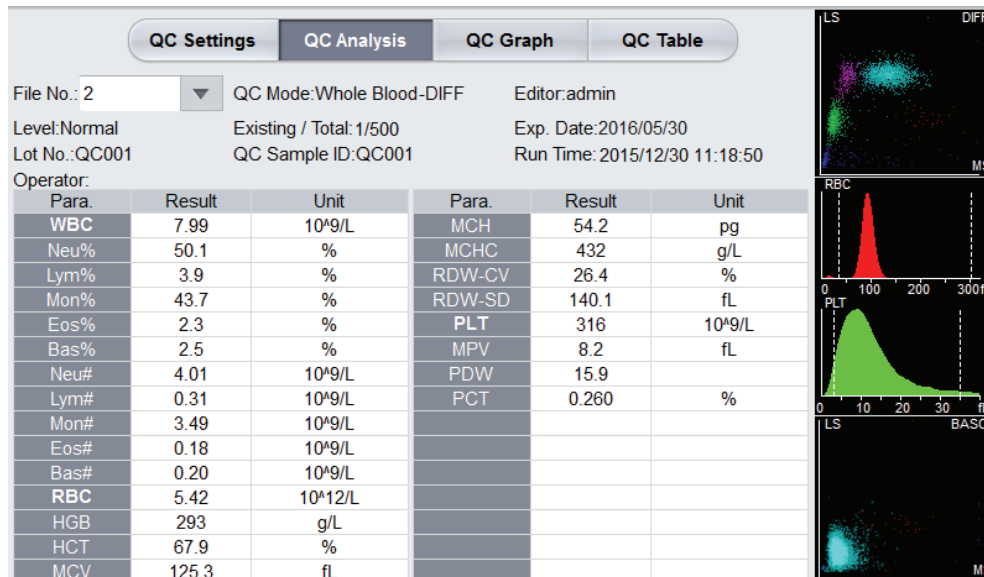

8. Perform the above procedures to continue running the controls if necessary.

NOTE

- If the QC file is outdated, its valid period will be displayed in red.
- “↑” or “↓” alarm symbol will be displayed next to the results with deviations exceeding the set limits.

9.2.3.2 Completing QC Analysis in the Sample Analysis Interface



All the samples, controls, calibrators, reagents, wastes and areas in contact with them are potentially biohazardous. Wear proper personal protective equipment (e.g. gloves, lab uniforms, etc.) and follow laboratory safety procedures when handling them and the relevant areas in the laboratory.

**WARNING**

- The sample probe is sharp and potentially biohazardous. Exercise caution to avoid contact with the probe when working around it.
 - The sample may spill from the unclosed collection tubes and cause biohazard. Exercise caution to the unclosed collection tubes.
 - Collection tubes broken may cause personal injury and/or biohazard. Be sure to place the collection tubes in the right adapter before running, otherwise, the collection tubes may be broken and cause biohazard.
 - Keep your clothes, hairs and hands away from the moving parts to avoid injury.
 - Reagents can be irritating to the eyes, skin, and mucosa. Wear proper personal protective equipment (e.g. gloves, lab uniforms, etc.) and follow laboratory safety procedures when handling them in the laboratory.
 - If the reagent accidentally comes in contact with your skin, wash it off immediately with plenty of water and see a doctor if necessary. Do the same if you accidentally get any of the reagent in your eyes.
-

**CAUTION**

- Running quality controls in presence of errors may lead to incorrect analysis results. If you see the error alarms when running the quality controls, please stop and resume the analysis until the errors are removed.
 - Do not re-use such disposable products as collection tubes, test tubes, capillary tubes, etc.
 - Sample clump may lead to incorrect analysis results. Check if clump exists before running the controls; if it does, handle it as per the related laboratory procedures.
-

NOTE

- You should only use the Dymind-specified controls and reagents. Store and use the controls and reagents as instructed by instructions for use of the controls and reagents. Using other controls may lead to incorrect QC results.
 - Before being used for analysis shake well the controls that have been settled for a while.
 - Be sure to use the Dymind-specified disposable products including vacutainer blood collection tube, vacutainer blood collection tubes with anticoagulant and capillary tubes etc.
 - If the blood-sample mode is **Predilute**, then a reminder of predilute counting will pop up if the user presses the aspirate key to perform the counting. To close the prompt, please refer to **5.9 Auxiliary Settings**.
-

After completing the QC settings, you can place the controls among the daily samples and perform analysis together in the **Sample Analysis** interface. After the analysis is completed, the system will store the results to the QC file with the corresponding ID.

Specific steps for performing QC analysis in the **Sample Analysis** interface are as follows:

1. Prepare the controls according to the set control mode and control instructions.

- If the QC mode is **Whole Blood-CBC+DIFF**, prepare Dymind-specified controls for blood cell classification.
- If the QC mode is **Predilute-CBC+DIFF**, predilute the controls for blood cell classification with reference to **6.5 Sample Collection and Handling** and get diluted QC samples.

NOTE

Be sure to evaluate predilute stability based on your laboratory's sample population and sample collection techniques or methods.

2. Click **Mode & ID** in the Sample Analysis screen.

The interface pops up a dialog box as shown below.

3. Enter the set QC Sample ID in the **Sample ID** edit box (other options can be ignored). Refer to **9.2.2.1 Entering QC Information** for the setting of the QC Sample ID.
4. Well mix the prepared controls.
5. In the ready for counting state (namely, the indicator light of the main unit is green), place the controls under the sample probe where the probe can aspirate the well-mixed controls.
6. Press the aspirate key and start running the controls. Upon the completion of the aspiration, you'll hear a beep and you can remove the controls.
When the running of the controls is complete, the QC results will be saved in the QC file automatically.
7. Perform the above procedures to continue running the controls if necessary.

NOTE

- If the QC file is outdated, its valid period will be displayed in red.
- “↑” or “↓” alarm symbol will be displayed next to the results with deviations exceeding the set limits.

9.2.3.3 Edit Result

Clicking **Edit Result** will allow you to edit the QC analysis result after the QC analysis is performed. See Figure 9-17.

Figure 9-17 Editing QC Results

Edit Result

WBC	<input type="text" value="8.00"/>	10 ⁹ /L	HGB	<input type="text"/>	g/L
Neu%	<input type="text"/>	%	HCT	<input type="text"/>	%
Lym%	<input type="text"/>	%	MCV	<input type="text"/>	fL
Mon%	<input type="text"/>	%	MCH	<input type="text"/>	pg
Eos%	<input type="text"/>	%	MCHC	<input type="text"/>	g/L
Bas%	<input type="text"/>	%	RDW-CV	<input type="text"/>	%
Neu#	<input type="text"/>	10 ⁹ /L	RDW-SD	<input type="text"/>	fL
Lym#	<input type="text"/>	10 ⁹ /L	PLT	<input type="text" value="210"/>	10 ⁹ /L
Mon#	<input type="text"/>	10 ⁹ /L	MPV	<input type="text"/>	fL
Eos#	<input type="text"/>	10 ⁹ /L	PDW	<input type="text"/>	
Bas#	<input type="text"/>	10 ⁹ /L	PCT	<input type="text"/>	%
RBC	<input type="text"/>	10 ¹² /L			

The edited data will be marked with an **E**. See the picture below.

Para.	Result	Unit
WBC	E 7.01	10 ³ /uL

9.2.3.4 Reviewing Previous/Next Records

You can click **Previous** to see the QC record prior to the current one, or click **Next** to see the QC record after the current one.

9.2.3.5 Print

You can click **Print** to print the QC record.

9.2.4 QC Result Review

After running controls, you can review the QC results in the following two forms:

- QC Graph
- QC Table

9.2.4.1 Graph



All the samples, controls, calibrators, reagents, wastes and areas in contact with them are potentially biohazardous. Wear proper personal protective equipment (e.g. gloves, lab uniforms, etc.) and follow laboratory safety procedures when handling them and the relevant areas in the laboratory.

You can review the result of L-J QC graph as per the following steps.

1. Click **QC** to access the QC interface.
2. Click **QC Graph** to enter the interface as shown in Figure 9-18.

Figure 9-18 L-J QC Graph Interface

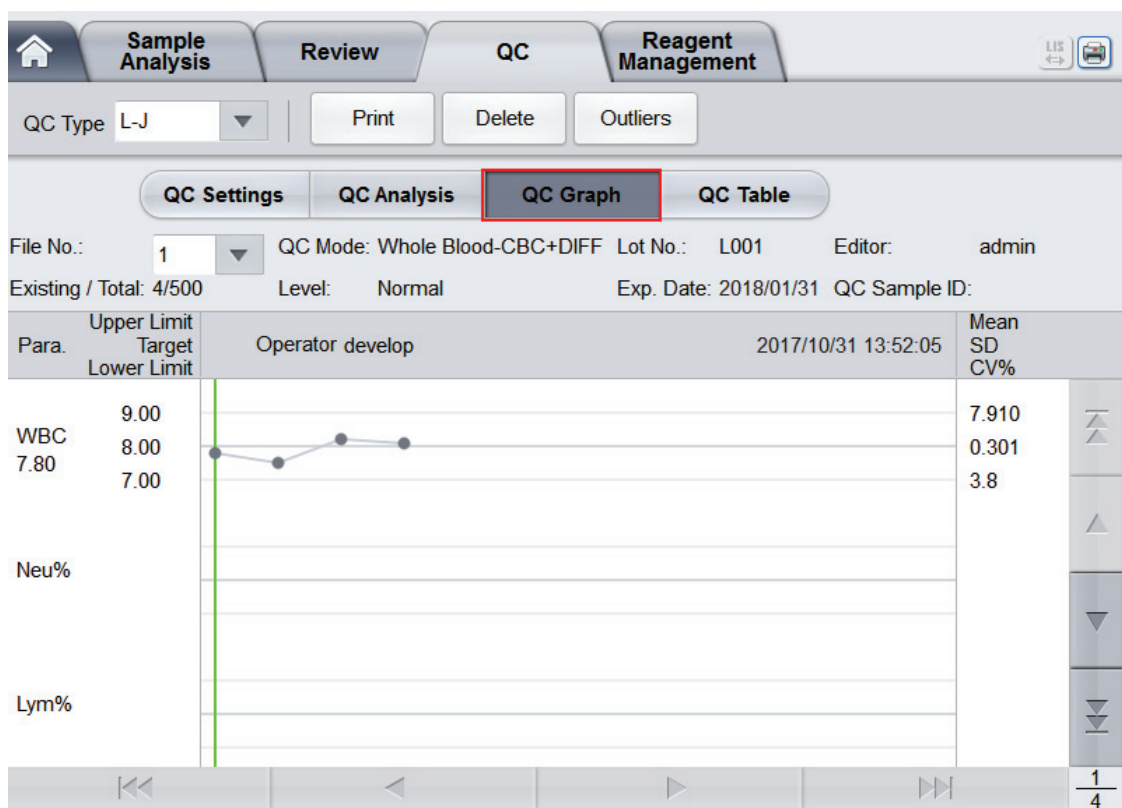

3. Select the QC file No. you want to review.
The screen will display the corresponding information and the graph. See Figure 9-19.

Figure 9-19 QC Graph

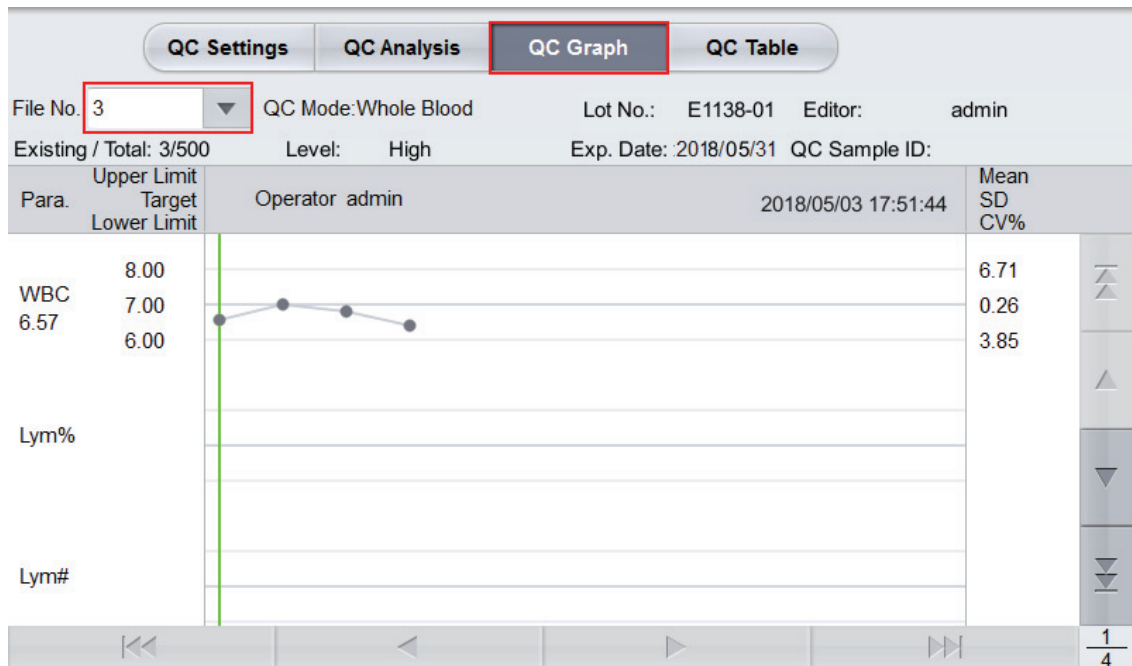

- Click the buttons at the right side of the QC graph, then you can browse QC graphs of different parameters; click the buttons at the bottom of the QC graph, then you can browse all QC results.

Introduction to the Graph Interface

Figure 9-20 L-J QC Graph Interface

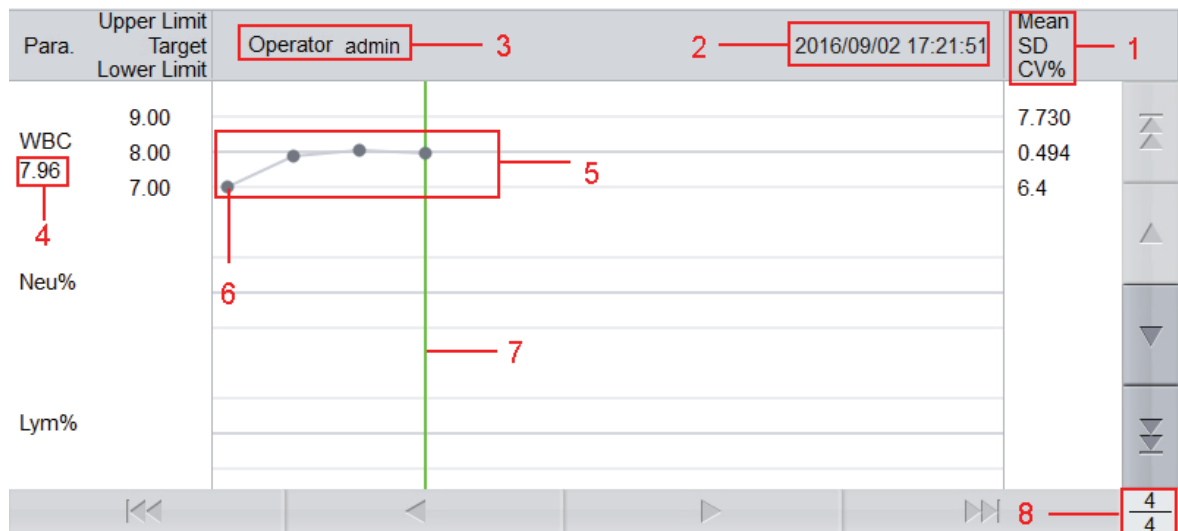

Interface Description:

- The Mean, SD and CV% of all the QC results of each parameter in the current graph.
- The saving date and time of the QC points located on the green line.
- The operator who run the QC analysis and obtained the QC points located on the green line.
- The QC results of the parameters that correspond to the QC points located on the green line.
- The QC points in each graph are displayed from left to right according to the sequence from the earliest to the latest. The QC points are connected by a line to illustrate the distribution trend.

6 - The QC point corresponds to each QC result. Only the selected QC point displays its value under the parameter. The black QC point indicates the value is within the limit; the red QC point indicates the value is out of the limit.

7 - When you clicking a QC point in the graph, the QC points of other parameters saved together with this one will be marked by a green line.

8 - The relative position of the QC point located on the green line and the total QC points saved currently.

NOTE

The outliers are excluded from the calculation of Mean, SD and CV%.

Delete

The administrator can delete the QC results by the following steps:

- Delete a single QC result
 - a. Move the green line to the desired QC result, and click **Delete**.
 - b. Select **Current Data** in the pop-up dialog box as shown in Figure 9-21.

Figure 9-21 Deleting Current QC Data (QC Graph)

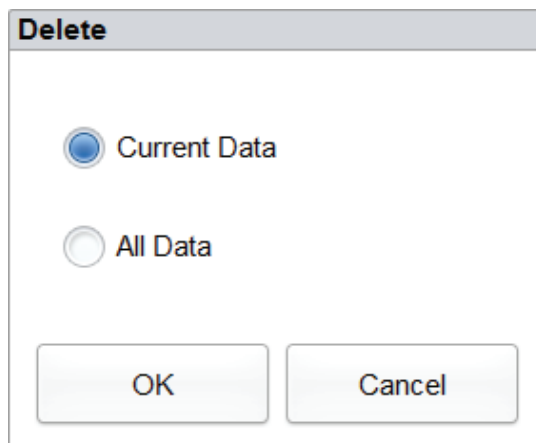

- c. Click **OK**.
- Deleting all the QC results in the current QC file
Click **Delete**, select **All Data** in the pop-up dialog box, then click **OK**. See Figure 9-22.

Figure 9-22 Deleting all QC Data (QC Graph)

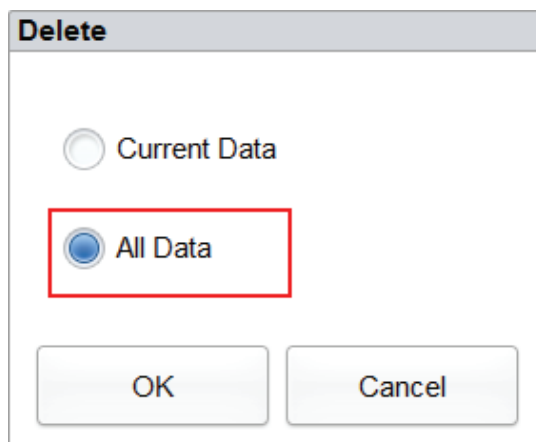

Entering the Reasons for the Outliers

Do as follows to enter the reasons for the outliers:

1. Move the green line to the desired QC point, and then click **Outliers**.

The pop-up window displays the QC results, reference values and deviation limits of all parameters corresponding to the green line as shown in Figure 9-23.

The QC results exceeding the limit will be displayed in red.

Figure 9-23 Enter Cause of Outliers

	WBC	Neu%	Lym%	Mon%	Eos%	Bas%	Neu#
Target	8.00						
Limits (#)	1.00						
Outliers Data	↓ 6.57						

Cause of Outliers

Control not Mixed Well
 Control Ineffective
 Control Expired
 Reagent Contaminated
 Reagent Expired
 Others

OK Cancel

2. You can select the reason from the given ones or manually enter the reasons (up to 200 characters) into the textbox after selecting **Others**.
3. Click **OK** to save the reasons for the outliers and exit.

NOTE

If you enter the reason for the group of QC points whose results are actually within the limits, then their corresponding QC data both in the QC Graph and QC Table will be displayed in red. And the data will return in black if you cancel the reason and then save the changes.

Print

You can have the QC data of the current page or all QC data in the QC file printed by clicking the Print button.

NOTE

The printed QC graph will not show any parameters which are not involved in the quality control.

Figure 9-25 Editing QC Results

	Date	Time	WBC
Target	/	/	7.07
Limits (#)	/	/	1.00
1	2015/08/21	11:30:21	E 6.08

Delete

With the administrator-level access, users can delete the selected QC data, QC data on the current page and all QC data.

- Delete a selected QC result
 - a. Click the column containing the desired QC result, and then click **Delete**.
 - b. Select **Current Data** in the pop-up dialog box as shown in Figure 9-26.

Figure 9-26 Deleting Current QC Data (QC Table)

The dialog box titled "Delete" contains three radio button options: "Current Data" (which is selected), "Current Page Data", and "All Data". At the bottom of the dialog are two buttons: "OK" and "Cancel".

- c. Click **OK**.
- Delete QC data on the current page
 - a. Click **Delete** on the page which contains the QC results expected to be deleted.
 - b. Select **Current Page Data** in the pop-up dialog box as shown in Figure 9-27.

Figure 9-27 Deleting all QC Data (QC Table)

The dialog box titled "Delete" contains three radio button options: "Current Data", "Current Page Data" (which is selected and highlighted with a red box), and "All Data". At the bottom of the dialog are two buttons: "OK" and "Cancel".

- c. Click **OK**.

- Delete all QC results

NOTE

Please be careful to perform this operation as it will delete all QC data of the selected QC file and cannot be reverted.

- Click **Delete**.
- Select **All Data** in the pop-up dialog box.

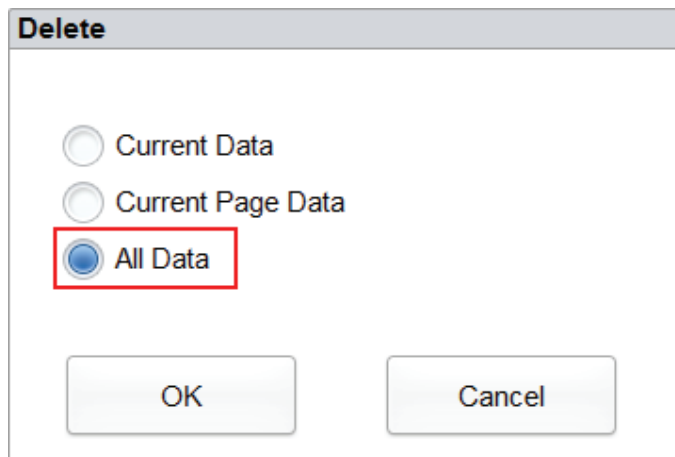

- Click **OK**.
The interface pops up a dialog box as shown below.

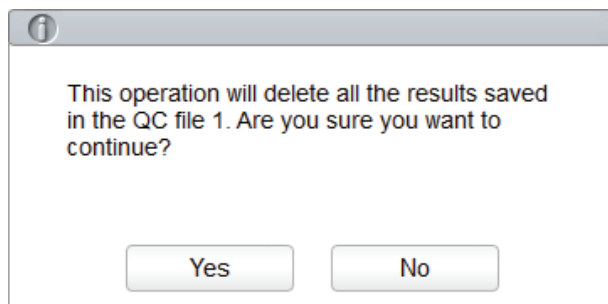

- Click **Yes** to delete all the QC results in the current QC file.

Print

You can print all the QC data or the data within the specified date range of the selected QC file. Detailed steps are shown below:

1. Select a QC file No. to be printed.
2. Click **Print**.

The interface pops up a dialog box as shown below.

3. Select the QC data to be printed: all data or specified data.
 - When **All Date** is selected, all the QC data of the table will be printed.
 - When **Specified Data** is selected, and the date range is set in the date controls, the QC data within the specified date range will be printed.
4. Click **OK** to print the data.

Communication

The current QC data, the data within the specified date range or all the QC data can be transmitted to LIS/HIS.

- Communication for current data
 - a. Select a QC record to be transmitted, and click **Comm.**.
A dialog box will pop up as shown in Figure 9-28. The default option is **Current Data**.

Figure 9-28 Communication for Current Data

- b. Click **OK**.

After the data is transmitted to LIS/HIS, a message box as shown below will pop up.

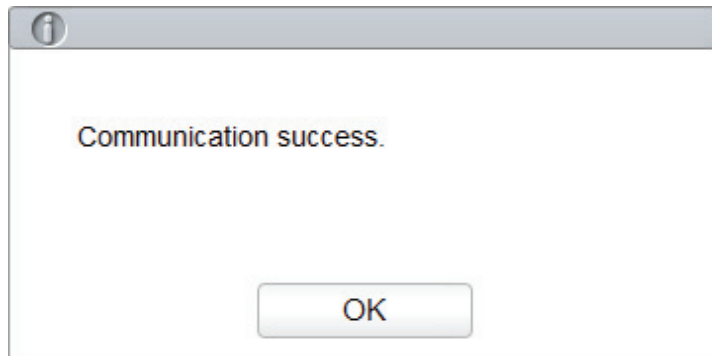

- c. Click **OK** to close the message box.

- Communication for all data

- a. Click **Comm..**

- b. Select **All Data**. See Figure 9-29.

Figure 9-29 Communication for all data

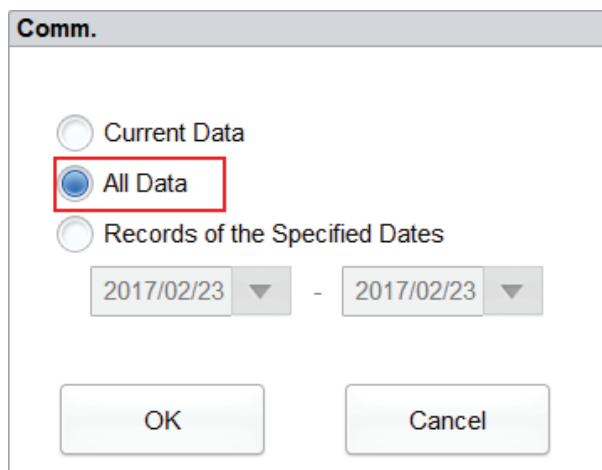

- c. Click **OK**.

After the data is transmitted to LIS/HIS, a message box as shown below will pop up.

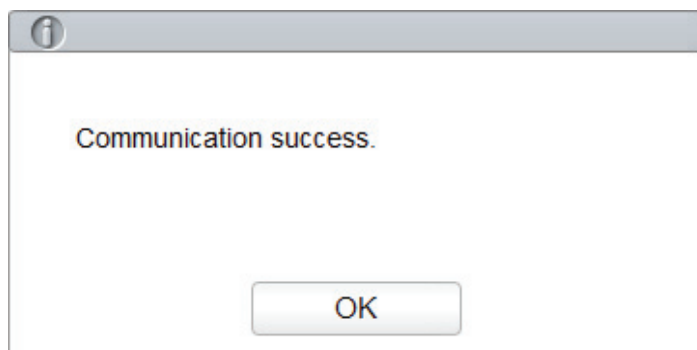

- d. Click **OK** to close the message box.

- Transmitting the data within specified date range

- a. Click **Comm..**

- b. Select **Records of the Specified Dates**, and set the starting and ending dates for the data to be communicated.

See Figure 9-30.

Figure 9-30 Communication for the Data within the Specified Date Range

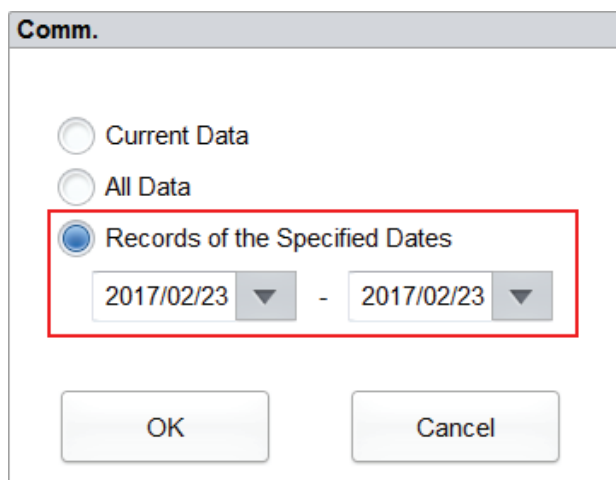

Comm.

Current Data

All Data

Records of the Specified Dates

2017/02/23 ▼ - 2017/02/23 ▼

OK Cancel

- c. Click **OK**.

After the data is transmitted to LIS/HIS, a message box as shown below will pop up.

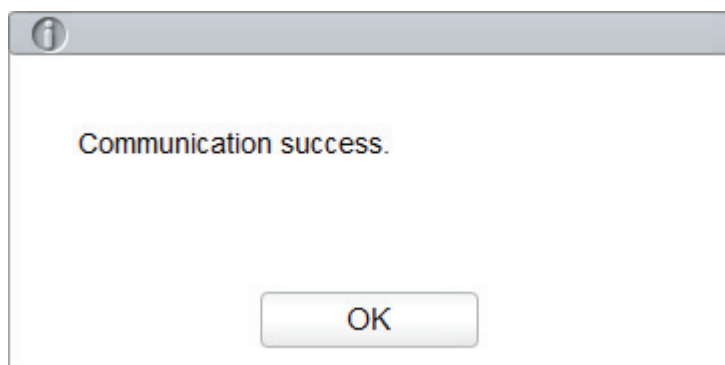

i

Communication success.

OK

- d. Click **OK** to close the message box.

Export

If you wish to export the information and the result of the current QC file, do as follows:

1. Insert a USB flash disk in the USB interface on the analyzer.
2. Click **Export**.

A dialog box will pop up as shown below.

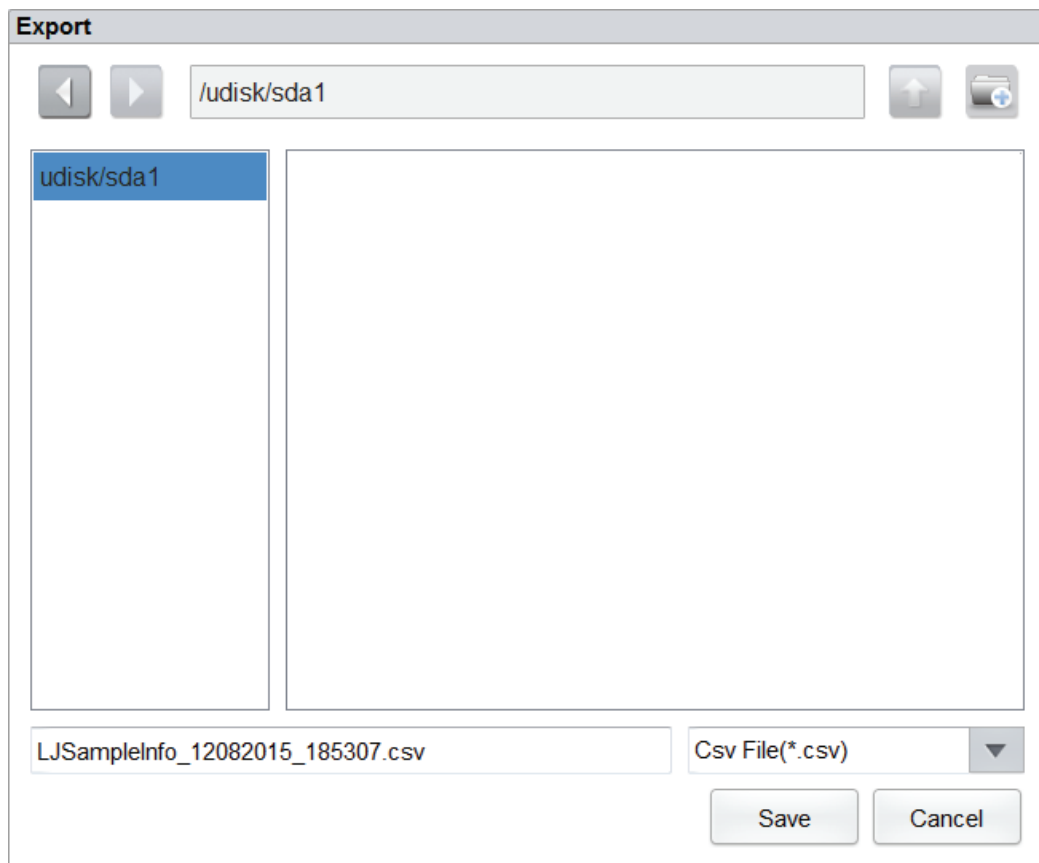

3. Select an export path for the data and enter the file name.

The file will be exported to the root directory of the USB flash disk (**/udisk/sda1**) and named in the format of **LJSampleInfo_YYYYMMdd_hhmmss.csv**. Among which, *YYYYMMdd_hhmmss* means data export year, month, date, hour, minute, and second.

4. Click **Save**.

When the export is finished, a message box as shown below will pop up.

Figure 9-31 Export successfully

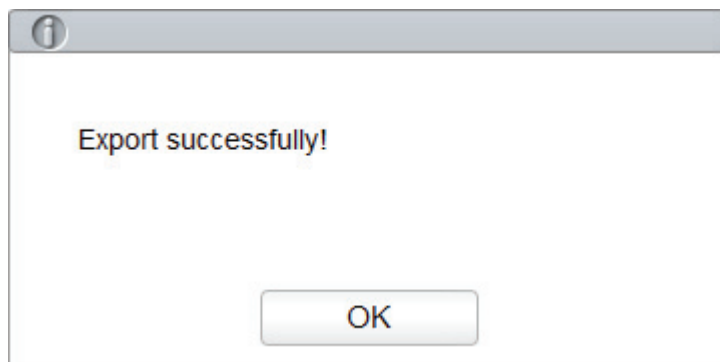

5. Click **OK** to close the message box.

9.3 X-B Quality Control

9.3.1 QC Principle

The X-B analysis is a weighted moving average analysis that uses values obtained from patient samples. It uses the 3 red cell indices, MCV, MCH and MCHC to indicate the hematology instrument performance. This is QC with no controls, which is a method of performance control like QC with controls. Both methods reflect the analysis performance of the analyzer from different perspective. Thus, one method should not be replaced with the other.

It is recommended the X-B analysis be activated when the sample volume of your laboratory is greater than 100 samples per day. Effective use of X-B requires randomization of samples and a normal cross section of patients to prevent skewing of indices. A reference range is established by the given reference values as well as lower and upper limits for the purpose of observing the variation of QC results within the reference range.

The analyzer performs X-B QC for three parameters, MCV, MCH, and MCHC. Twenty to two hundred samples can be grouped together for X-B numerical analysis. The samples are derived from the results of normal analyzer counting, with no distinction of whole-blood or predilute mode. The analyzer can save maximum 500 X-B QC results. When the saved QC results have reached the maximum number, the newest result will overwrite the oldest.

9.3.2 QC Settings



All the samples, controls, calibrators, reagents, wastes and areas in contact with them are potentially biohazardous. Wear proper personal protective equipment (e.g. gloves, lab uniforms, etc.) and follow laboratory safety procedures when handling them and the relevant areas in the laboratory.

NOTE

Only users with administrator-level access can edit the L-J settings.

Perform the QC Settings before running the controls. You can complete the QC settings by entering the QC information.

9.3.2.1 Entering QC Information

You can complete the X-B QC settings as per the following steps:

1. Click **QC** to access the **QC** interface.
2. Select **X-B** from the dropdown list of the **QC Type**.
3. Click **QC Settings**.

You'll enter the **QC Settings** interface as shown in Figure 9-32.

Figure 9-32 X-B QC Settings

X-B Editor

Samples/Group [20 200]

X-B Open Close

Target/Limits

Para.	Target	Limits (#)
MCV	89.5	2.7
MCH	30.5	0.9
MCHC	340	10

Sample Validity Setting

Para.	Lower Limit	Upper Limit
RBC	1.00	8.00
MCV	50.0	150.0
MCH	20.0	40.0
MCHC	240	440

- In the **Samples/Group** edit box, enter the amount of samples to be included in calculating for an X-B QC point.

The range is between 20 and 200 and the recommended value is 20.

NOTE

Once the **Samples/Group** is changed, the number of valid sample results will be recalculated. For example, if 20 valid samples are needed for the X-B QC calculation, when you change the value of **Samples/Group** after 10 group of valid sample results have been acquired, these 10 group of results will be discarded, and only valid sample results generated afterwards will be used in the QC calculation.

- Click the **Open** button of **X-B** to open the X-B quality control.
The samples results will be included to calculate the X-B.
- Enter the targets and limits for the QC parameters.

NOTE

- All the targets and limits for the QC parameters must be entered.
- When first use, the default setting will provide the Initial values for the targets and limits of the three QC parameters.
- If the QC data have existed in the QC file, you are not allowed to edit the target and limits.

You can set the display form of the limits or the calculation method of the limits among the preset values. See section **9.3.2.2 Setting Limits**.

- Set the valid upper and lower limits for the QC parameter in **Sample Validity Setting** field.

Setting sample validity is to set the valid range of four QC parameters, RBC, MCV, MCH and MCHC. To be incorporated into X-B QC calculation, the sample results should satisfy the validity ranges of all these four parameters.

NOTE

Once the **Samples/Group** is changed, the number of valid sample results will be recalculated. For example, if 20 valid samples are needed for the X-B QC calculation, when you change the value of **Samples/Group** after 10 group of valid sample results have been acquired, these 10 group of results will be discarded, and only valid sample results generated afterwards will be used in the QC calculation.

- Click the **Save** button to save all the settings of the QC.

If the entered value exceeds the acceptable range or the upper limit is lower than the lower limit, a reminder message will pop up and you will be prompted to re-enter the correct data and save the entry again.

9.3.2.2 Setting Limits

You can take the following steps to adjust the display format of the limits and the calculation method of the preset limits.

- Click **Set Limits**.

The interface pops up a dialog box as shown below.

The screenshot shows a dialog box titled "Set Limits". It has a blue header bar with the title. Below the header, there are two main sections. The first section is "By SD", which is selected with a blue radio button. Below this section are two radio buttons: "2SD" (selected) and "3SD". The second section is "By CV", which is unselected. Below this section are two radio buttons: "2CV" and "3CV". At the bottom of the dialog are two buttons: "OK" and "Cancel".

- Select **By SD** or **By CV** according to the actual needs.
 - If **By SD** is selected, the limits will be displayed in form of absolute value. Click **2SD** or **3SD** to select either double or triple standard deviation to be the limits.
 - If **By CV** is selected, the limits will be displayed in form of percentage. Click **2CV** or **3CV** to select either double or triple coefficient of variation to be the limits.
- Click **OK** to save all the settings for the limits.

9.3.2.3 Restoring Defaults

In QC setting, click **Restore Defaults** button to restore the parameter reference values, limits and sample validity to the default settings.

NOTE

- If the QC data have existed in the QC file, you are not allowed to restore the parameters.
 - Clicking **Restore Defaults** can only store the default settings of **Target, Limits** and **Sample Validity Setting**, while **Samples/Group**, X-B QC switch and limit settings cannot be restored.
-

9.3.3 Quality Control Analysis



All the samples, controls, calibrators, reagents, wastes and areas in contact with them are potentially biohazardous. Wear proper personal protective equipment (e.g. gloves, lab uniforms, etc.) and follow laboratory safety procedures when handling them and the relevant areas in the laboratory.

After the QC settings, the analyzer will automatically start the X-B QC analysis.

After every 20~200 results (determined by the setting) are obtained, the system will perform the X-B calculation once automatically. You can review the result in X-B graph or X-B table.

In X-B QC, sample results conforming to any of the following conditions will be considered as invalid and can not be used in the QC calculation.

- Sample results exceeding the linearity range
- Background results
- Sample results not conforming to the **Sample Validity Setting**
- QC data for other QC programs (such as L-J QC)
- Calibration data
- Results generated while there are errors which could affect the accuracy of the results (insufficient aspiration volume or clogging for example).

9.3.4 QC Result Review

After running controls, you can review the QC results in the following two forms:

- QC Graph
- QC Table

9.3.4.1 Graph



All the samples, controls, calibrators, reagents, wastes and areas in contact with them are potentially biohazardous. Wear proper personal protective equipment (e.g. gloves, lab uniforms, etc.) and follow laboratory safety procedures when handling them and the relevant areas in the laboratory.

Access the X-B QC Graph interface by taking the following steps:

1. Click **QC** to access the **QC** interface.
2. Select **X-B** from the dropdown list of the **QC Type**.
3. Click **Graph**.

The X-B QC Graph interface will be displayed. See Figure 9-33.

Figure 9-33 QC Graph

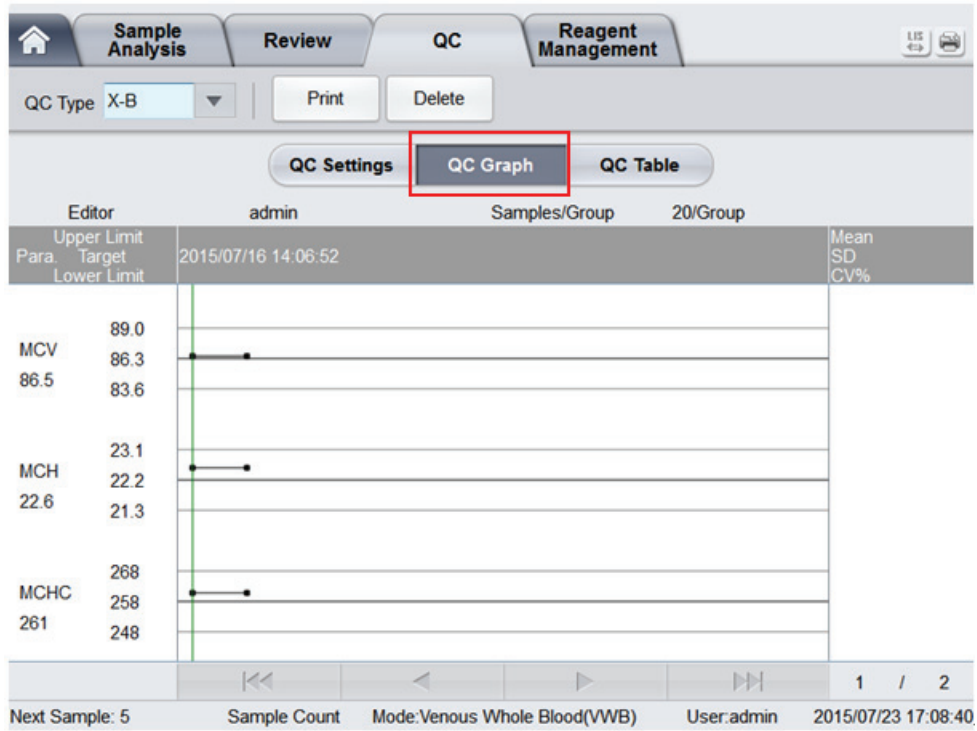

4. You can also drag the scroll bar down to the graph horizontally to browse all the QC results.

Introduction to the Graph Interface

Figure 9-34 X-B QC Graph

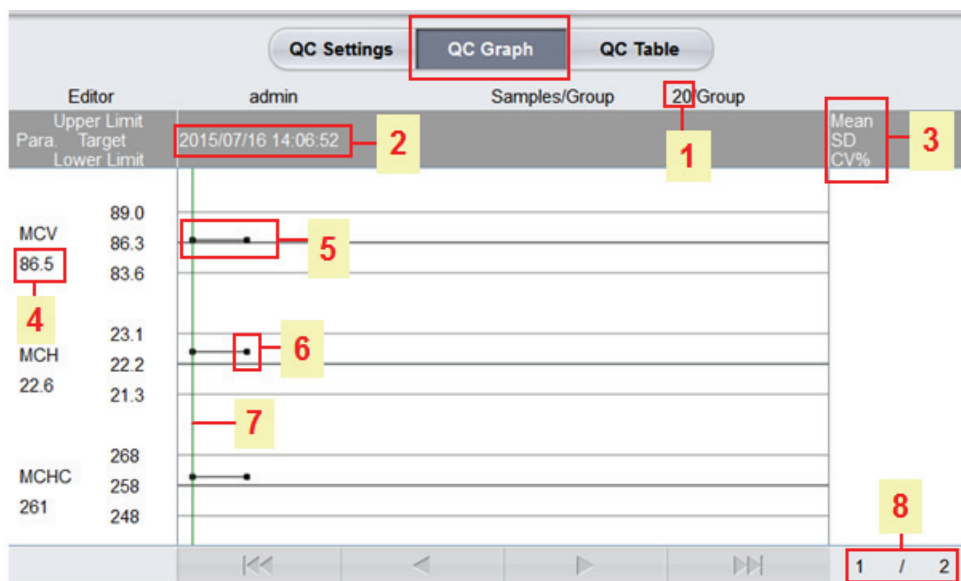

- 1 - The amount of samples included in calculating for each QC point.
- 2 - The saving date and time of the QC points located on the green line
- 3 - The Mean, SD and CV% of all the QC results of each parameter in the current graph.
- 4 - The QC results of the parameters that correspond to the QC points located on the green line.
- 5 - The QC points in each graph are displayed from left to right according to the sequence from the earliest to the latest. The QC points are connected by a line to illustrate the distribution trend.
- 6 - The QC point corresponds to each QC result. Only the selected QC point displays its value under the parameter. The black QC point indicates the value is within the limit; the red QC point indicates the value is out of the limit.
- 7 - When you clicking a QC point in the graph, the QC points of other parameters saved together with this one will be marked by a green line.
- 8 - The relative position of the QC point located on the green line and the total QC points saved currently.

Delete

The administrator can delete the QC results by the following steps:

- Delete a single QC result
 - a. Move the green line to the desired QC result, and click **Delete**.
 - b. Select **Current Data** in the pop-up dialog box as shown in Figure 9-35.

Figure 9-35 Deleting Current QC Data (QC Graph)

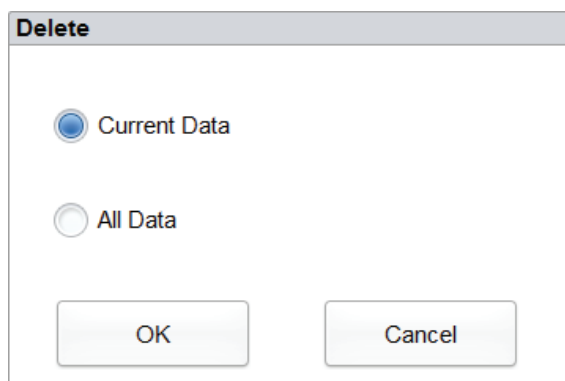

- c. Click **OK**.
- Deleting all the QC results in the current QC file
Click **Delete**, select **All Data** in the pop-up dialog box, then click **OK**. See Figure 9-36.

Figure 9-36 Deleting all QC Data (QC Graph)

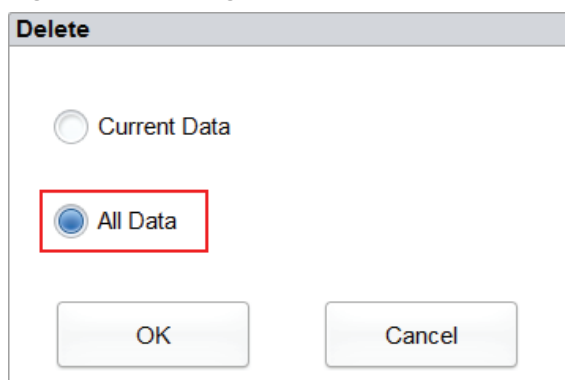

Print

Click the **Print** button to print the QC graph.

9.3.4.2 Table



All the samples, controls, calibrators, reagents, wastes and areas in contact with them are potentially biohazardous. Wear proper personal protective equipment (e.g. gloves, lab uniforms, etc.) and follow laboratory safety procedures when handling them and the relevant areas in the laboratory.

Access the X-B QC Table interface by taking the following steps:

1. Click **QC** to access the QC interface.
2. Select **X-B** from the dropdown list of the **QC Type**.
3. Click **QC Table**.

The X-B QC table interface will be displayed. See Figure 9-37.

Figure 9-37 QC Table

Editor	admin		Samples/Group	1/Group	
	Date	Time	MCV	MCH	MCHC
Target	/	/	89.5	30.5	34.0
Limits (#)	/	/	2.7	0.9	1.0
1	2015/08/14	18:06:04	91.1	30.6	34.5
2	2015/08/17	15:50:55	↑ 101.1	30.9	33.3

Introduction to the QC Table Interface

Editor	admin		Samples/Group	1 Group	2	
	Date	Time	MCV	MCH	MCHC	
Target	/	/	89.5	30.5	34.0	
Limits (#)	/	/	2.7	0.9	1.0	
1	2015/08/14	18:06:04	91.1	30.6	34.5	
2	2015/08/17	15:50:55	↑ 101.1	30.9	33.3	

- 1 - The amount of samples included in calculating for each QC point.
- 2 - QC parameters (displayed in the same order as the **QC Graph** screen).
- 3 - The No. of the QC result saved in the QC file (arranged from left to right in the order that from the earliest to the latest).
- 4 - QC Result. The value of the QC result is the X-B result of each group of samples.
- 5 - QC flag: The flag ↑ or ↓ will be used to prompt the result that out of the limits

Delete

With the administrator-level access, users can delete the selected QC data, QC data on the current page and all QC data.

- Delete a selected QC result
 - a. Click the column containing the desired QC result, and then click **Delete**.
 - b. Select Current Data in the pop-up dialog box as shown in Figure 9-38.

Figure 9-38 Deleting Current QC Data (QC Table)

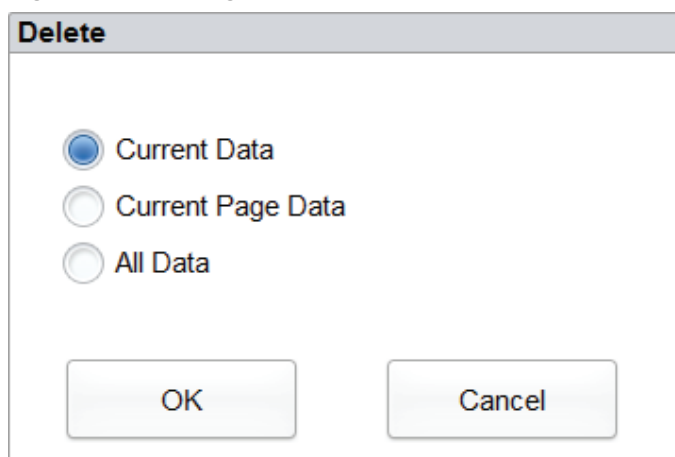

- c. Click **OK**.
- Delete QC data on the current page
 - a. Click **Delete** on the page which contains the QC results expected to be deleted.
 - b. Select **Current Page Data** in the pop-up dialog box as shown in Figure 9-39.

Figure 9-39 Deleting all QC Data (QC Table)

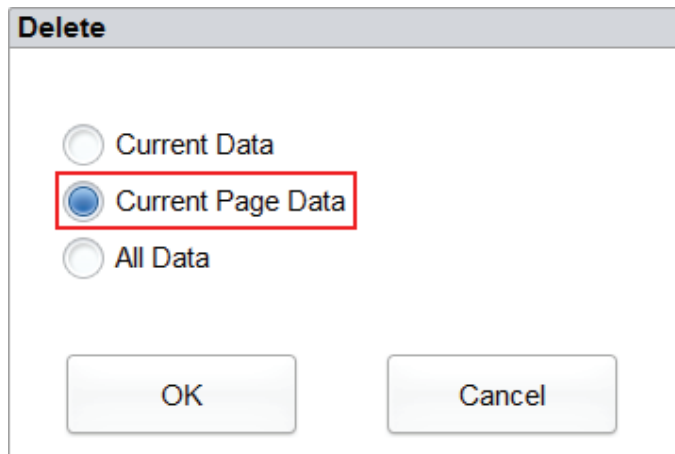

c. Click **OK**.

- Delete all QC results

NOTE

Please be careful to perform this operation as it will delete all QC data of the selected QC file and cannot be reverted.

- Click **Delete**.
- Select **All Data** in the pop-up dialog box.

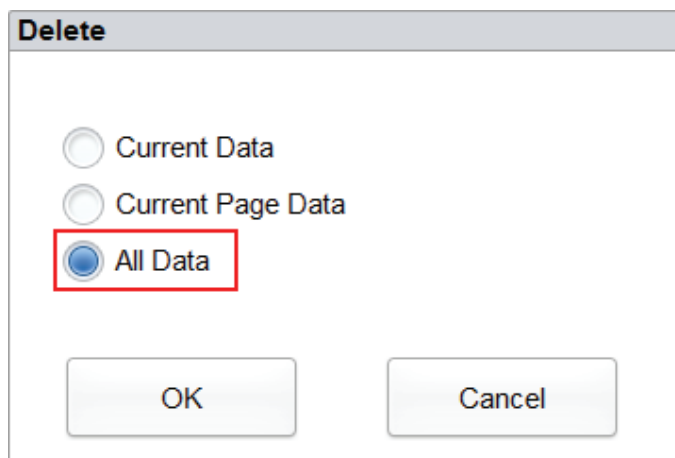

c. Click **OK**.

The interface pops up a dialog box as shown below.

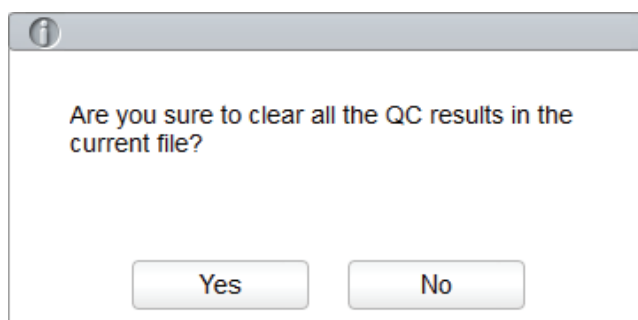

d. Click **Yes** to delete all the QC results in the current QC file.

Print

You can print all the QC data or the data within the specified date range of the selected QC file. Detailed steps are shown below:

1. Select a QC file No. to be printed.
2. Click **Print**.

The interface pops up a dialog box as shown in Figure 9-40.

Figure 9-40 Print

3. Select the QC data to be printed: all data or specified data.
 - When **All Data** is selected, all the QC data of the table will be printed.
 - When **Specified Data** is selected, and the date range is set in the date controls, the QC data within the specified date range will be printed.
4. Click **OK** to print the data.

Communication

The current QC data, the data within the specified date range or all the QC data can be transmitted to LIS/HIS.

- Communication for current data
 - a. Select a QC record to be transmitted, and click **Comm..**

A dialog box will pop up as shown in Figure 9-41. The default option is **Current Data**.

Figure 9-41 Communication for Current Data

- b. Click **OK**.

After the data is transmitted to LIS/HIS, a message box as shown below will pop up.

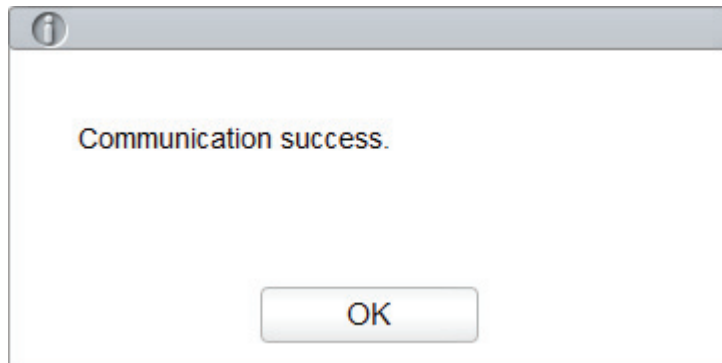

- c. Click **OK** to close the message box.

- Communication for all data

- a. Click **Comm.**.

- b. Select **All Data**. See Figure 9-42.

Figure 9-42 Communication for all data

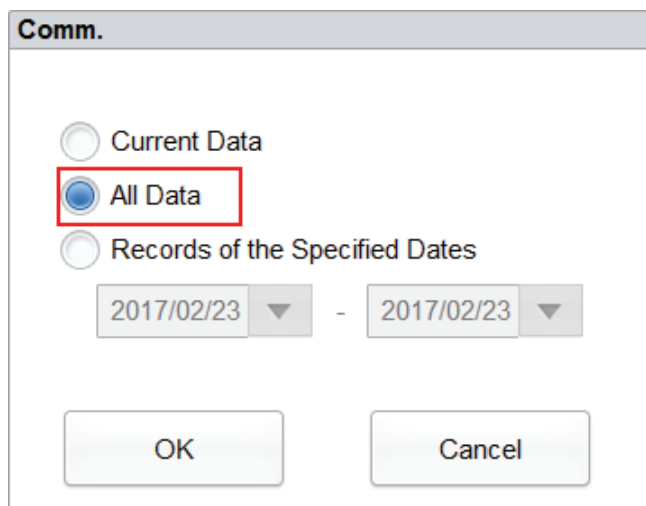

- c. Click **OK**.

After the data is transmitted to LIS/HIS, a message box as shown below will pop up.

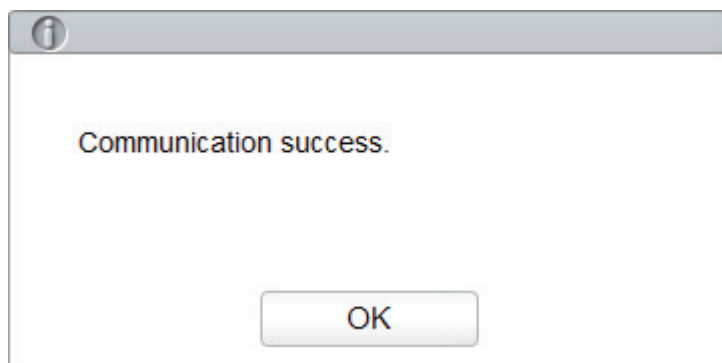

- d. Click **OK** to close the message box.

- Transmitting the data within specified date range
 - a. Click **Comm.**
 - b. Select **Records of the Speified Dates**, and set the starting and ending dates for the data to be communicated.
See Figure 9-43.

Figure 9-43 Communication for the Data within the Specified Date Range

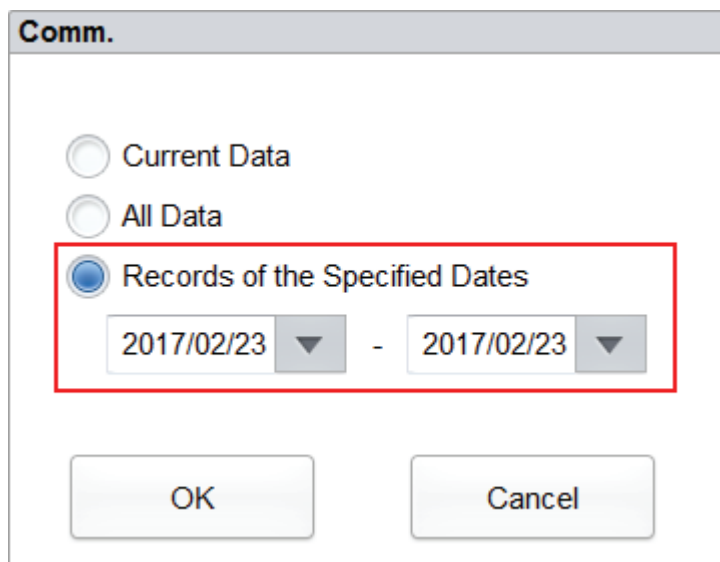

Comm.

Current Data

All Data

Records of the Specified Dates

2017/02/23 - 2017/02/23

OK Cancel

- c. Click **OK**.
After the data is transmitted to LIS/HIS, a message box as shown below will pop up.

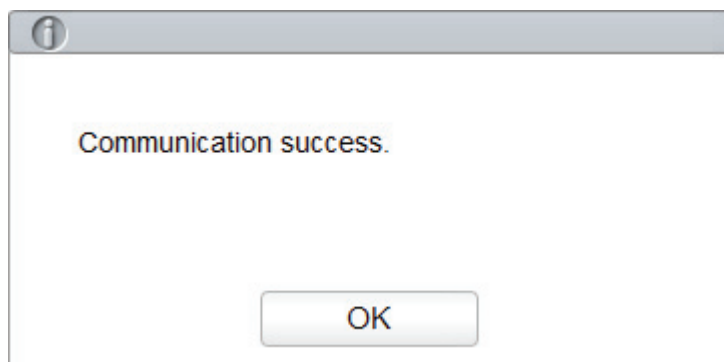

i

Communication success.

OK

- d. Click **OK** to close the message box.

Export

If you wish to export the information and the result of the current QC file, do as follows:

1. Insert a USB flash disk in the USB interface on the analyzer.
2. Click **Export**.

A dialog box will pop up as shown in Figure 9-44.

Figure 9-44 Export

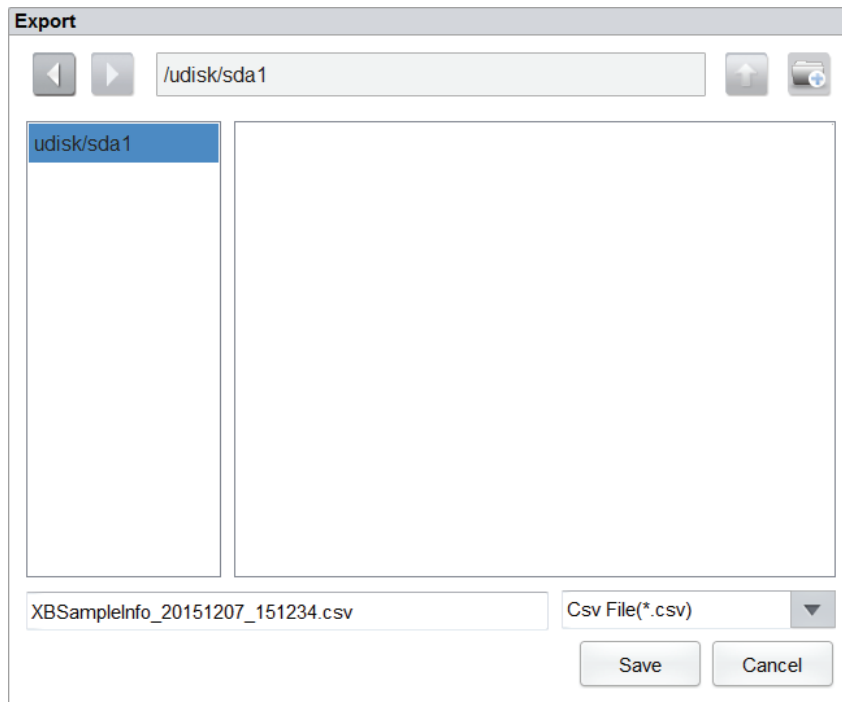

3. Select an export path for the data and enter the file name.

The file will be exported to the root directory of the USB flash disk (**/udisk/sda1**) and named in the format of **XBSampleInfo_YYYYMMDD_hhmmss.csv**. Among which, **YYYYMMDD_hhmmss** means data export year, month, date, hour, minute, and second.

4. Click **Save**.

When the export is finished, a message box as shown below will pop up.

Figure 9-45 Export successfully

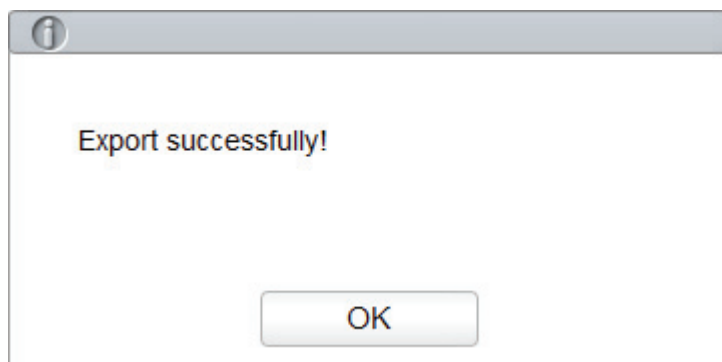

5. Click **OK** to close the message box.

10 Calibration

10.1 Introduction

Calibration is a procedure to standardize the analyzer by determining its deviation, if any, from calibration references and to apply any necessary correction factors. To get accurate blood analysis results, perform calibration of the analyzer following the procedures given in this chapter when it's needed.

NOTE

- Calibration procedures can only be performed by users with the administrator-level access. The login users with the access level of general users can not perform the calibration procedures but only browse the calibration coefficients.
 - You should only use the Dymind-specified calibrators and reagents. Store and use the calibrator and reagents following the instructions for use of the calibrations and reagents.
 - The analyzer identifies a sample as a calibration sample only if the analysis is started from the **Cal** interface.
 - The calculation of repeatability is included in the calibration procedure.
-

10.2 When to Calibrate

This analyzer is calibrated at the factory just before shipment. It is electronically stable and does not require frequent recalibration if you operate and maintain it as instructed by this manual. You need to recalibrate this analyzer if:

- it is the first time this analyzer has been used (usually done by a Dymind-authorized representative when installing the analyzer).
 - an analytical component has been changed.
 - the quality control results indicate that there may be a problem.
 - the operating environment (such as the temperature) has changed significantly.
-

NOTE

- All of the measured parameters must be calibrated before readings of this analyzer can be used as valid analysis results.
 - For laboratories conducting routine tests, the calibration should be applied at least once every six months.
-

10.3 How to Calibrate

There are three calibration programs available on this analyzer: manual calibration, auto calibration using calibrators and auto calibration using fresh blood samples.

All or part of the parameters of WBC, RBC, HGB, MCV and PLT can be calibrated by the calibration procedure.

10.3.1 Preparation



All the samples, controls, calibrators, reagents, wastes and areas in contact with them are potentially biohazardous. Wear proper personal protective equipment (e.g. gloves, lab uniforms, etc.) and follow laboratory safety procedures when handling them and the relevant areas in the laboratory.



WARNING

- The sample probe tip is sharp and may contain biohazardous materials. Exercise caution to avoid contact with the probe when working around it.
 - Reagents can be irritating to the eyes, skin, and mucosa. Wear proper personal protective equipment (e.g. gloves, lab uniforms, etc.) and follow laboratory safety procedures when handling them in the laboratory.
 - If the reagent accidentally comes in contact with your skin, wash it off immediately with plenty of water and see a doctor if necessary. Do the same if you accidentally get any of the reagent in your eyes.
 - Keep your clothes, hairs and hands away from the moving parts to avoid injury.
 - Be sure to dispose of reagents, waste, samples, consumables, etc. according to local legislations and regulations.
-



CAUTION

Do not re-use such disposable products as collection tubes, test tubes, capillary tubes, etc.

NOTE

- You should only use the Dymind-specified calibrators and reagents. Store and use the calibrator and reagents following the instructions for use of the calibrations and reagents.
 - Be sure to use the Dymind-specified disposable products including vacutainer blood collection tube, vacutainer blood collection tubes with anticoagulant and capillary tubes etc.
-

Carry out the calibration only when the background range, repeatability and carryover are within the specified limits given in the manual, otherwise, the problems must be identified and solved before you determine if calibration is needed. If you cannot solve the problems, please contact Dymind Service Department.

1. Check and make sure enough reagents have been prepared for the calibration. You need to start over the calibration if the reagents run out during the process.
2. Do the background check.
If the analyzer alarms are activated for abnormal background results, see **13 Troubleshooting** for solutions.(Refer to **A.4.2 Normal Background** for background range.)
3. Do the repeatability test.
 - a. Select **Whole Blood** mode in the **Sample Analysis** to run the median controls consecutively for 10 times
 - b. Check the 10 counting results above in the **Review** interface and make sure they are within the range specified in **A.4.4 Repeatability**.
4. Do the carryover test.
 - a. Run the corresponding diluent for 3 times immediately after running the high-level controls for 3 times.
 - b. Calculate the carryover by the following formulae:

$$\text{Carryover (\%)} = \frac{\text{First low-value sample result} - \text{Third low-level sample result}}{\text{Third high-value sample result} - \text{Third low-level sample result}} \times 100\%$$

The calculated carryovers shall meet the requirements in **A.4.5 Carryover**.

5. It is recommended that you create a log table for your analyzer. The suggested items that you may want to include in the log table are: calibration date, supplier of calibrator, lot number, expected results and limits, and result of background check.

10.3.2 Manual Calibration

Complete the manual calibration as per the following procedure:

1. Click **Cal** in the menu page to access the calibration interface.
2. Click **Manual** to access the manual calibration interface. See Figure 10-1.

Figure 10-1 Manual Calibration

Whole Blood			Predilute		
Para.	Cal. Coefficient (%)	Cal. Date	Para.	Cal. Coefficient (%)	Cal. Date
WBC	100.00		WBC	100.00	
RBC	100.00		RBC	100.00	
HGB	100.00		HGB	100.00	
MCV	100.00		MCV	100.00	
PLT	100.00		PLT	100.00	

The calibration coefficients of whole blood mode and predilute mode are displayed on the Manual interface.

NOTE

The login users with the access level of general users can not perform the calibration procedures but only browse the calibration coefficients on the current screen. To perform the calibration, please log out and then log in as users with administrator-level access.

3. Check the calibration coefficient and calculate the new coefficient using the following equation.

$$\text{New calibration factor} = \frac{\text{Current calibration factor} \times \text{Reference value}}{\text{Mean}}$$

For example, the WBC reference value of a calibrator is 8.3, and the current calibration coefficient of the whole blood mode is 99.00%.

Run the calibrator in whole blood mode for 10 consecutive times and calculate the WBC results of the 1st to 10th runs (n=10): 8.4, 8.2, 8.2, 8.3, 8.3, 8.1, 8.2, 8.1, 8.2, 8.2. The obtained CV is 1.1% and the Mean is 8.22, which meet the requirements.

The new calibration coefficient is obtained:

$$\text{New calibration factor} = \frac{99.00\% \times 8.3}{8.22} = 99.96\%$$

The calculated calibration coefficients shall be between 75%~125%. In case of an invalid calibration coefficient, try to find out the reason (e.g. calibration material not thoroughly mixed, incorrect operation, etc.). Then recalibrate the analyzer and recalculate the calibration coefficients.

4. Enter the new calibration coefficients into the factor cell of the parameter that requires calibration.

NOTE

The entered calibration coefficients shall be between 75.0%~125.0% (calculation results rounded to two decimal places).

5. Click **Save**.

- If the new calibration coefficient is valid and different from the original value, the following dialog box will pop up.

Figure 10-2 Calibration set successfully

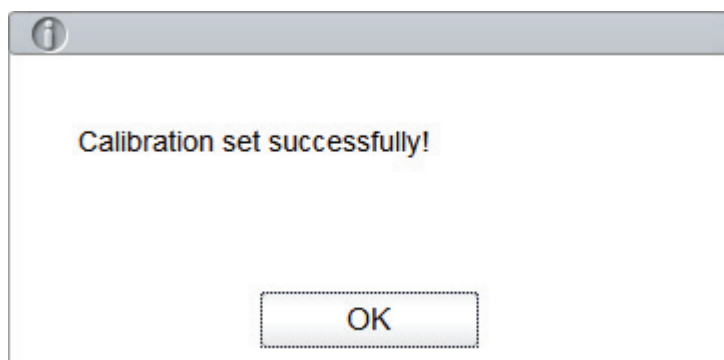

On the screen, the calibration coefficient is refreshed to be the new one and the calibration date is refreshed to be the current system date.

- If the new calibration coefficients are invalid, the message box will pop up. Click **OK** to close the message box and enter a valid factor.

Figure 10-3 Invalid Coefficients

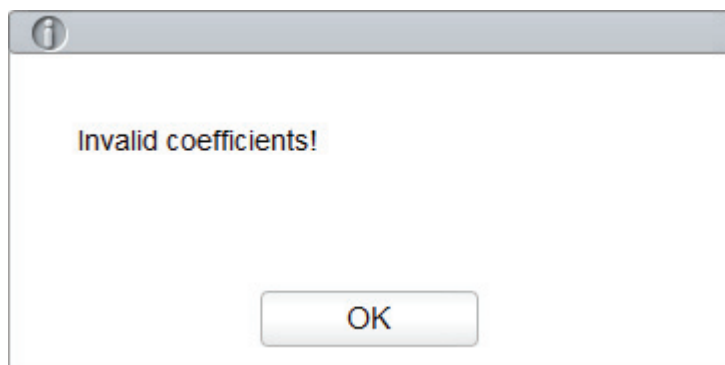

6. (Optional) Click **Print** to print the current calibration coefficient.
7. Click **Exit** to close the Manual interface.

10.3.3 Auto Calibration Using Calibrators



All the samples, controls, calibrators, reagents, wastes and areas in contact with them are potentially biohazardous. Wear proper personal protective equipment (e.g. gloves, lab uniforms, etc.) and follow laboratory safety procedures when handling them and the relevant areas in the laboratory.

NOTE

- Only Dymind-specified calibrators shall be used. Dymind will not be responsible for any erroneous result caused by using other calibrators.
- See the instructions for use of the calibrators for the lot No., Exp. Date and the target.

Complete the calibration with calibrators as per the following procedure:

1. Click **Cal** in the menu page to access the calibration interface.
2. Click **Calibrator**.

The **Calibrator** interface pops up as shown in Figure 10-4.

Figure 10-4 Auto Calibration Using Calibrators

Para.	WBC	RBC	HGB	MCV	PLT	Lot No.
Target						<input type="text"/>
<input type="checkbox"/> 1						Exp. Date
<input type="checkbox"/> 2						12-30-2015
<input type="checkbox"/> 3						Mode
<input type="checkbox"/> 4						<input checked="" type="radio"/> Whole Blood
<input type="checkbox"/> 5						
<input type="checkbox"/> 6						
<input type="checkbox"/> 7						
<input type="checkbox"/> 8						
<input type="checkbox"/> 9						
<input type="checkbox"/> 10						
Mean						
CV(%)						
New Calibration Coefficient (%)						
Original Calibration Coefficient (%)	100.00	100.00	100.00	100.00	100.00	

3. Enter the lot No. of the calibrator into the Lot No. box.
4. Click the **Exp. Date** box, and then edit the **Exp. Date**.

NOTE

- The **Exp. Date** can be no earlier than the current system date.
 - The entered **Exp. Date** should be either the **Exp. Date** printed on the labeling or the open-container expiration date, whichever is earlier. The open-container expiration date is calculated as follows: the date on which the container is opened + the open-container stability days.
5. Input the target values of the parameters in the corresponding cell of the **Target**.
 6. Prepare the calibrators following their instructions for use and place the calibrators under the sampling probe.
 7. Press the aspirate key to start the calibration counting.

After every calibration run, the progress bar will close automatically and the analyzer will have different responses according to different analysis results.

 - The valid results within the linearity range will be displayed directly.
 - If the calibration counting data of any parameter in the current counting are out of the display range or linearity range of the parameter, a message box will pop up on the screen prompting that the calibration data is invalid.

Click **OK** to close the message box and delete the data from the table without saving.
 - If any of the parameter's value in the calibration counting differs from the Target value by more than 50%, the system will prompt you with a message box asking if the calibration counting results should be kept.

To keep the results, click **Yes**; to remove the results, click **No**.

NOTE

- After the valid calibration result is obtained, the parameters with corresponding checkboxes ticked off will be involved in the calculation of the calibration coefficients by default.
- If you switch to other interfaces before the new calibration coefficients are obtained, the system will discard the current calibration data and keep the original calibration coefficients.

8. To get 10 valid counting results, repeat steps 6~7 ten times.

The analyzer will, by default, calculate the Mean, CV% and the new calibration coefficients based on all the ticked-off calibration data according to the formulae.

9. Select at least 5 groups of data for the calculation of the calibration coefficients.

When the amount of the valid calibration data in the list reaches 10, a message box of **Calibrator calibration done!** will pop up. Click **OK** to close the message box.

If the calibration coefficients are invalid, click **Yes** to close the dialog box. Then click **Clear** to delete the current data and redo the calibration.

NOTE

The out-of-range CV% does not influence the display of the calibration coefficients.

10. Click **Save**.

- If the calculated calibration coefficients of all parameter are within the range of 75%~125% and the CV% of all parameter are also within the repeatability, then a dialog box prompting the successful calibration setting will pop up. Click **OK** to close the message box.
- If the obtained calibration coefficient of any parameter is not within the range of 75%~125% or the CV% of any calibrated parameter does not meet the repeatability, the calibration coefficient will not be saved and a dialog box indicating invalid new calibration coefficient will pop up. Click **Yes** to close the dialog box and repeat the calibration operations.

11. (Optional) Click **Print** to print the calibration results.

10.3.4 Auto Calibration Using Fresh Blood Samples



All the samples, controls, calibrators, reagents, wastes and areas in contact with them are potentially biohazardous. Wear proper personal protective equipment (e.g. gloves, lab uniforms, etc.) and follow laboratory safety procedures when handling them and the relevant areas in the laboratory.

Complete the calibration using fresh blood samples as per the following procedure:

1. Click **Cal** in the menu page to access the calibration interface.
2. Click **Fresh Blood**.

The fresh blood sample calibration interface pop up, as shown in Figure 10-5.

Figure 10-5 Auto Calibration Using Fresh Blood Samples

Para.	WBC	RBC	HGB	MCV	PLT
Target					
1					
2					
3					
4					
5					
6					
7					
8					
9					
10					
Mean					
CV(%)					
Calibration Coefficient 1 (%)					

Blood Sample

Blood Sample 1

Blood Sample 2

Blood Sample 3

Blood Sample 4

Blood Sample 5

Mode

Whole Blood

Calculate

Clear

Print

3. Prepare 3 to 5 normal fresh blood samples as instructed by **6.5 Sample Collection and Handling**.
4. Run each of the prepared samples on the reference instrument three times at least. Average the results for your reference values.

NOTE

The reference instrument must be a properly running standard analyzer so as to ensure the accuracy of the reference values.

5. Enter the reference values for the parameters to be calibrated in the corresponding **Target** textbox.
6. Place the blood sample under the sampling probe, press the aspirate key on the analyzer to run the samples.
The system will calculate the values for WBC, RBC, HGB, MCV and PLT of the sample.
7. Repeat step 6 for 10 times and calculate the counting results for sample No. 1 in the 10 runs.
The system will calculate the Mean, CV and Calibration coefficient for each parameter of the sample.
If the obtained calibration coefficient for any sample is not within the valid range or CV% or any calibrated parameters does not meet the repeatability, a dialog box indicating invalid new calibration coefficient will pop up. Click **Clear** to delete the calibration data of the sample. Redo the calibration or redo the calibration with another sample meeting all criteria.
8. Refer to steps 6~7 and perform the counting operations for the remaining four blood samples.
The system will calculate the Mean, CV and Calibration Coefficient for each parameter of the remaining 4 blood samples.
9. Click **Calculate**.
The system will calculate the average of the calibration coefficients, namely, the mean calibration coefficient (%), as the new calibration coefficient based on the five blood samples.

You can also check at least three accurate calibration coefficients and the system will re-calculate the mean calibration coefficient (%).

NOTE

The mean calibration coefficient is invalid if its absolute value of deviation from the original calibration coefficient is greater than or equal to 5%.

10. Click **Save**.

- If the mean calibration coefficient is within the valid range (the absolute value of deviation from the original calibration coefficient is less than 5%), you'll be prompted that the mean calibration coefficient is saved successfully.
 - If the mean calibration coefficient is not within the valid range (the absolute value of deviation from the original calibration coefficient is greater than or equal to 5%), you'll be prompted that the mean calibration coefficient is invalid.
-

NOTE

CV% out of standard will not affect the display of calibration coefficient.

11. (Optional) Click **Print** to print the calibration results.

10.4 Verifying Calibration Coefficients

It is recommended that you take the following steps to verify the calibration coefficients:

1. Run the calibrator at least three times and check whether the means of the obtained results are within the expected ranges.
2. Run the low-, normal- and high-level controls each for three times at least, and check whether the means of the obtained results are within the expected ranges.
3. Run at least three fresh blood samples with known reference values, each for six times at least, and check whether the means of the obtained results are within the expected ranges.

11 Reagent Management

Once the new reagent is connected to the analyzer, you can set the reagent configurations, including validity period, residue volume and reagent barcode on the Reagent Management interface. Upon the completion of reagent configuration, you can perform the procedures for reagent replacement.



WARNING

- Reagents can be irritating to the eyes, skin, and mucosa. Wear proper personal protective equipment (e.g. gloves, lab uniforms, etc.) and follow laboratory safety procedures when handling them in the laboratory.
- If the reagent accidentally comes in contact with your skin, wash it off immediately with plenty of water and see a doctor if necessary. Do the same if you accidentally get any of the reagent in your eyes.

NOTE

- After long-distance transportation, the reagent must be allowed to settle for more than one day before use.
- When you have changed the diluents, cleansers or lyses, run a background check to see if the results meet the requirement.

11.1 Accessing the Interface

Click **Reagent Management** in the menu navigation area, to access the reagent management setting interface. See Figure 11-1.

Figure 11-1 Reagent Management

Reagent Name	Exp. Date	Open-container Date	Period After Opening	Open-container Exp. Date	Residue Volume
DIL-C Diluent					
LYC-1 Lyse					
LYC-2 Lyse					

Refer to Table 11-1 for related parameter descriptions.

Table 11-1 Parameter Description for Reagent Management

Parameter	NOTE
Current Model	Current model of the analyzer. <ul style="list-style-type: none"> • Open system • Closed system Reagent setting procedures for different analyzer models vary, please refer to 11.2 Setting Reagent Information .
Reagent Name	Name of the reagent.
Exp. Date	Exp. Date of the unopened reagent will be shown upon the completion of the reagent settings. Any reagent, regardless of its container being opened or not, should not be used beyond this date.
Open-container Date	The date on which the reagent container is opened. The default open-container date is the date on which the reagent settings are completed.
Period after opening (PAO)	The validity period (days) after the reagent container is opened. It will be shown upon the completion of the reagent settings.
Open-container Exp. Date	expiration date of the opened reagent, and it will be shown upon the completion of the reagent settings.
Residue Volume	The current residue volume of the reagent, and it will be shown in ml upon the completion of the reagent settings. The unit is ml.

11.2 Setting Reagent Information

Once the new reagent is connected to the analyzer, you should set the reagent configurations, including validity period, residue volume and reagent barcode on the **Reagent Management** interface. Upon the completion of reagent configuration, you can perform the procedures for reagent replacement.

Reagent setting procedures for different analyzer models vary. The reagent setting procedures for both open and closed models will be presented on the following pages.

11.2.1 Open System

For open systems, reagent setting procedures are as follows:

1. Select the reagent to be set, and then click **Setup**.

This launches the **Reagent Information** page as shown in Figure 11-2.



Figure 11-2 Reagent Information

2. To enter the reagent information, use any of the following methods.

➤ Manual Entry

Detailed parameter description is shown in Table 11-2.

Table 11-2 Parameter Description of Reagent Information

Parameter	It means	Operation
Reagent Name	Name of the reagent to be set.	Input in the textbox directly.
Exp. Date	The expiration date of the unopened reagent (see the outer packaging of the reagent). Any reagent, regardless of its container being opened or not, should not be used beyond this date.	<p>Click the date control for the settings.</p> <ul style="list-style-type: none"> The input sequence of the controls is year, month, and date. Click  or  to select a date and time or enter the information in the textbox directly. Click  to clear the current data and re-enter the information. <p>NOTE</p> <p>The validity date of the reagent can be no later than the validity date indicated on the packaging and cannot be earlier than the current system date.</p>
Period after opening (PAO)	The validity period (days) of the open-container reagent (see the product packaging).	Input in the textbox directly.
Residue Volume	The current residue volume of the reagent (ml).	Input in the textbox directly.

- Manually input the reagent barcode, and click Load; or input the barcode via a peripheral barcode scanner.

A correctly entered barcode will prompt a message shown below the barcode box, indicating a successful loading, and the validity date and residue volume will be shown in the corresponding textboxes.

If the bar code fails to be loaded, check if the reagent has been used or has expired and the reagent name is correct. If all the information is correct, but the failure persists, please contact Dymind After-sales Service Department.

3. Click **Apply**.

The system message will pop up, indicating the successful reagent settings.

Figure 11-3 Successful Reagent Settings

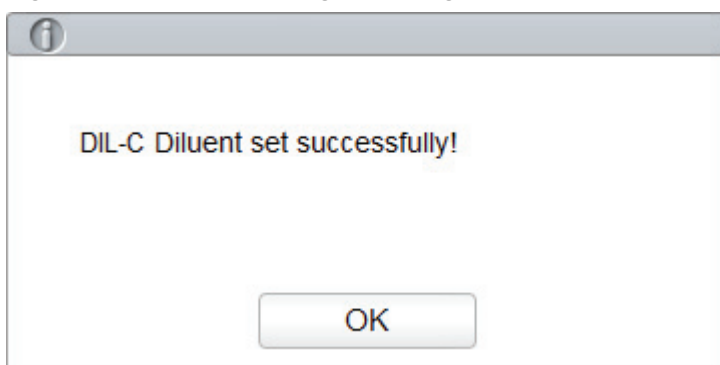

4. Click **OK**.
5. Continue to perform 1~4 and set the other reagent information; or click  to exit the setting interface.

NOTE

Once the reagent settings are successfully completed, the system prompt at the top right corner of the screen will show that the reagent has not been replaced. To remove this error, click the error message and then click **Remove Error** in the pop-up dialog box. The analyzer will complete the replacement of the reagent and remove the error. When you have changed the reagents, run a background check to see if the results meet the requirement.

11.2.2 Closed System

There are two types of reagents for the closed system: open reagents and closed reagents.

- For open reagents, see the settings of the open system in **11.2.1 Open System**.
- For closed reagents, the reagent setup is disabled normally. The setup is only required when the Insufficient reagent error is prompted.

Taking **Insufficient LYC-1** as an example, this section introduces the setting procedures for the closed reagent.

1. When the **Insufficient LYC-1** is prompted on the upper right of the screen, double click the message.
2. Select the error name in the popup dialog box, and click **Remove Error**.

A dialog box as shown in Figure 11-4 pops up.

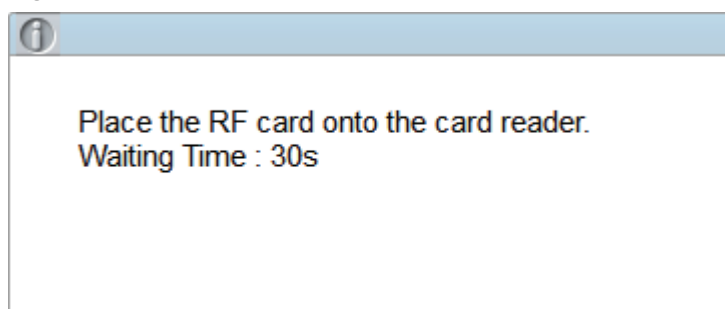
Figure 11-4 RF Card Verification

- Put the RF card attached to reagent packing on the RF card reader in front of the analyzer. The beeping of the card reader and a pop-up dialog box as shown in Figure 11-5 indicate the successful reagent settings.

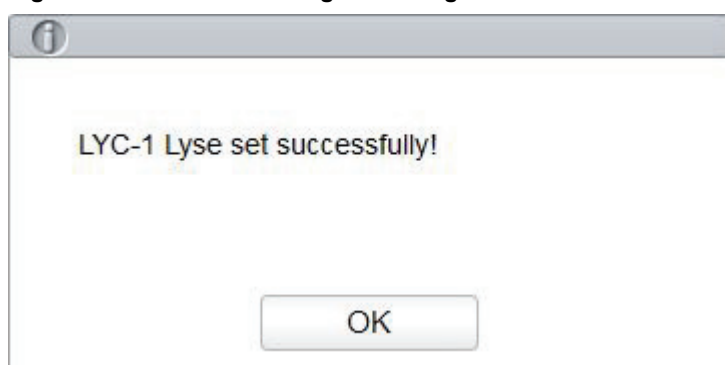
Figure 11-5 Successful Reagent Settings

NOTE

If RF card verification fails, please follow the system prompts and use a valid RF card for re-reading.

- Click **OK**.

NOTE

- Once the reagent settings are successfully completed, the system prompt at the top right corner of the screen will show that the reagent has not been replaced. To remove this error, click the error message and then click **Remove Error** in the pop-up dialog box. The analyzer will complete the replacement of the reagent and remove the error. When you have changed the reagents, run a background check to see if the results meet the requirement.
 - You can set the reagent margin by clicking **Purchase Reminder** in the **Reagent Management** interface. When the reagent margin is less than the value as you set, a message box pops up to prompt you to purchase new reagents in time.
-

11.3 Replacing Reagents

After completing the reagent settings, you should perform the reagent replacement operations. You can select to replace one type of reagent at a time or all reagents. The method is applied as follows:

1. Select a type of reagent to be replaced, and click Replace; or click Replace All to replace all the reagents.

After the replacement is completed, a message box as shown below will pop up on the screen.

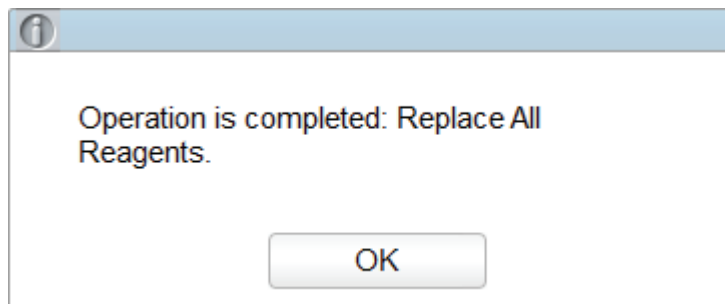

2. Click **OK** to close the message box.

NOTE

When you have changed the reagents, run a background check to see if the results meet the requirement.

12 Service

12.1 Introduction

This analyzer provides multiple maintenance functions for this purpose. This chapter introduces how to use the provided functions to maintain and troubleshoot your analyzer. Preventive and corrective maintenance procedures are required to keep the analyzer in a good operating condition.



All the analyzer components and surfaces are potentially infectious, take proper protective measures for operation or maintenance.



CAUTION

- Performing unauthorized maintenance procedures can damage your analyzer. Do not perform any maintenance procedures that are not described in this chapter.
 - In case of problems not specified in this manual, contact Dymind customer service department or your local agent for assistance.
 - Only Dymind-supplied parts can be used for maintenance. For any question, contact Dymind customer service department or your local agent.
 - Exercise caution to avoid contact with the sharp sample probe when performing maintenance.
-

12.2 Maintenance

The analyzer provides multiple service functions helping users to perform daily maintenance.

12.2.1 Reagent Replacement



WARNING

- Reagents can be irritating to the eyes, skin, and mucosa. Wear proper personal protective equipment (e.g. gloves, lab uniforms, etc.) and follow laboratory safety procedures when handling them in the laboratory.
 - If the reagent accidentally comes in contact with your skin, wash it off immediately with plenty of water and see a doctor if necessary. Do the same if you accidentally get any of the reagent in your eyes.
-

NOTE

- After long-distance transportation, the reagent must be allowed to settle for more than one day before use.
 - When you have changed the diluents, cleansers or lysers, run a background check to see if the results meet the requirement.
-

You should replace the reagents when:

- The system indicates that the reagent is used up
- The suspicious flag indicates that the reagent in the pipeline is contaminated
- The reagent is contaminated or expired
- WBC or RBC bubbles are identified.

You can replace any of the following reagents:

- DIL-C Diluent
- LYC-2 Lyse
- LYC-1 Lyse

Do as follows to replace the reagents:

1. Refer to Figure 2-2 in **2.6.2 Reagent Connections** for reagent connections.
2. Click the **Service** icon in the menu page to access the **Service** interface as shown in Figure 12-1.

Figure 12-1 Service

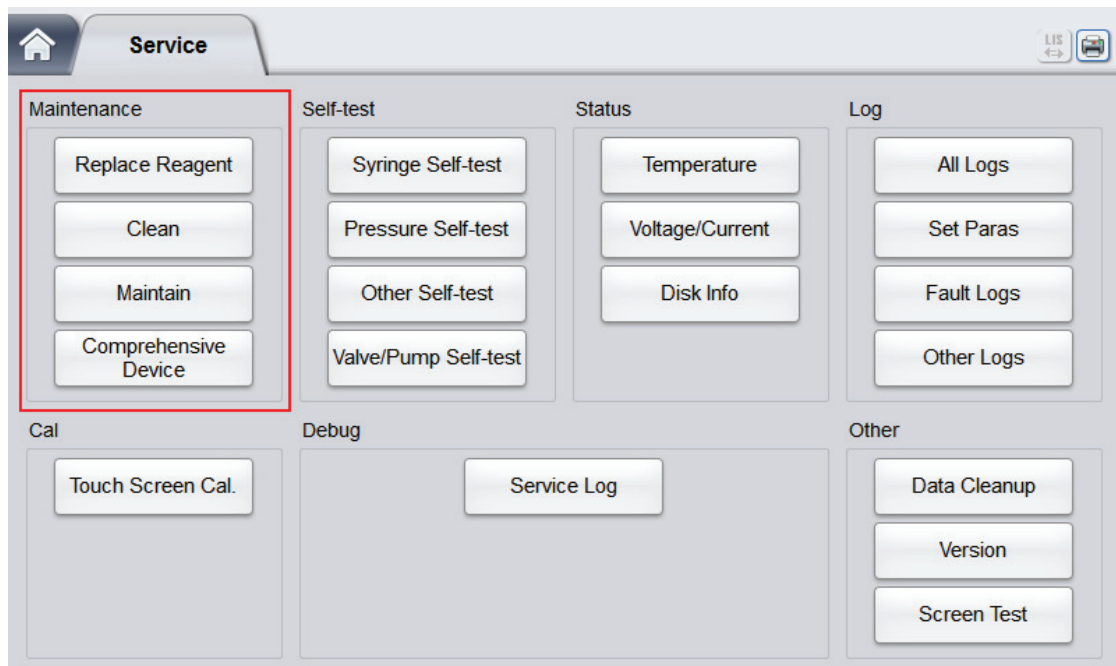

3. Click **Replace Reagent** in the **Maintenance** selection.
The interface as shown in Figure 12-2 will pop up on the screen.

Figure 12-2 Reagent Replacement

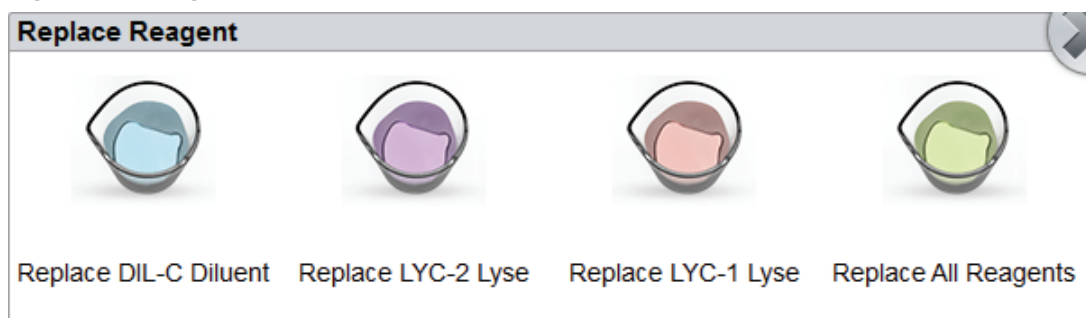

4. Click the name of the reagent that needs to be replaced, such as **Replace All Reagents**.
After the replacement is completed, the following message box will pop up.

Figure 12-3 Reagent Replaced

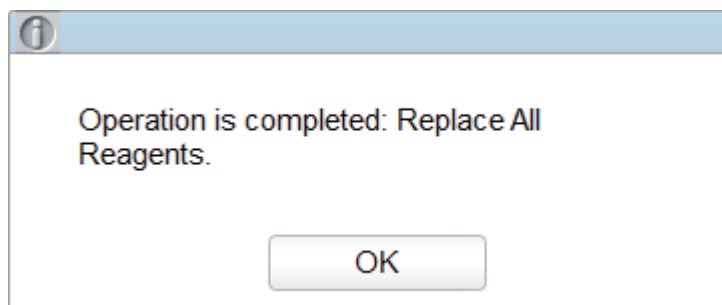

5. Click **OK** to close the message box.
6. Perform the above procedures to replace other reagents if necessary.

12.2.2 Cleaning

Clean corresponding parts according to the actual situation:

- WBC bath

You should clean the WBC bath when:

- the background of the scattergram has abnormal excessive cells
- the background of WBC- and/or HGB-specific parameters exceeds the reference range

- RBC bath

When the background of RBC- and (or) PLT-specific parameters exceeds the reference range, you should clean the RBC bath.

- Flow chamber

When the background of the scattergram has abnormal excessive cells, or bad differential of WBC, you should clean the flow chamber.

- Sample probe

When the sample probe is dirty, you should clean the sample probe.

The cleaning procedures are as follows:

1. Click the **Service** icon in the menu page to access the **Service** interface.

Figure 12-4 Service

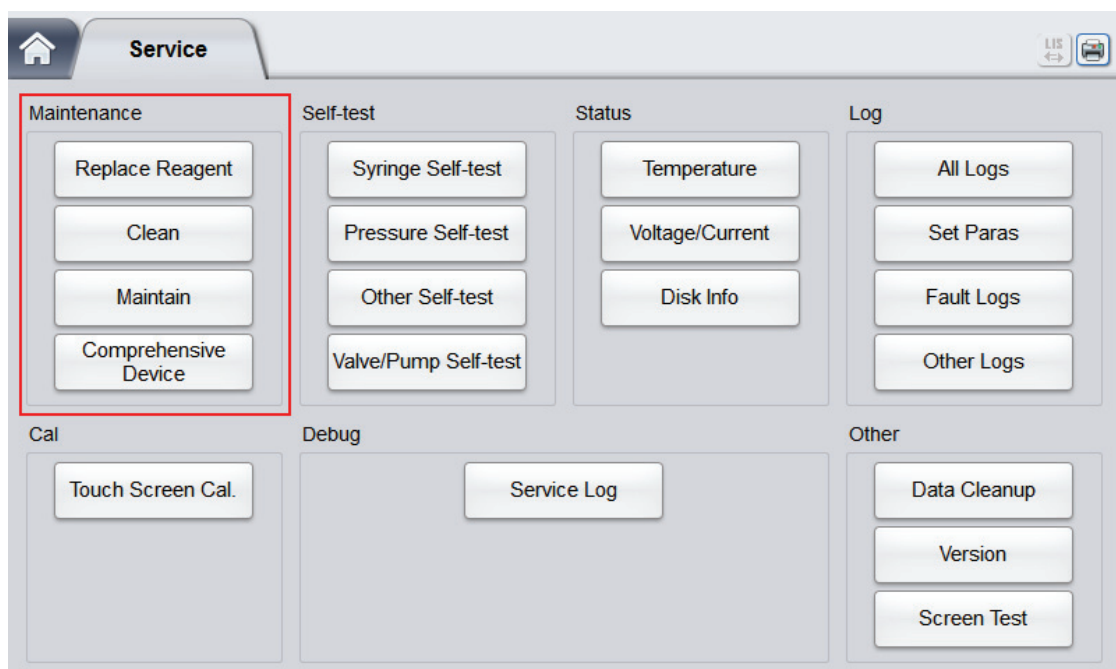

2. Click **Clean** in the **Maintenance** selection, an interface as shown in Figure 12-5 will pop up on the screen.

Figure 12-5 Cleaning

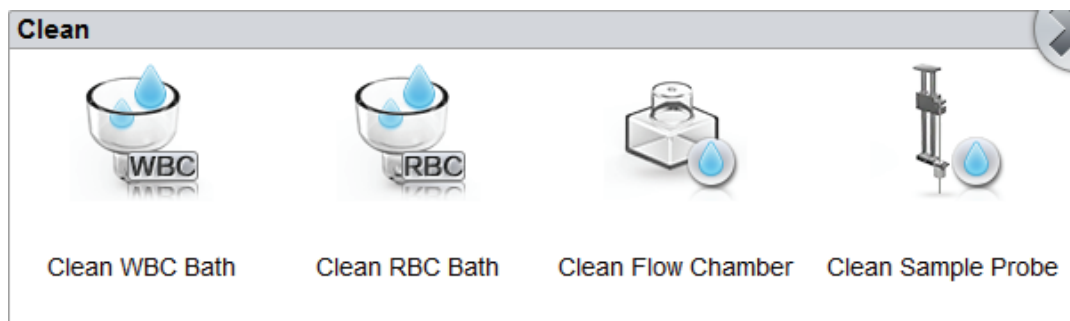

3. Click the icon of the part that needs to be cleaned, such as **Clean Sample Probe**.
When the system cleaning is complete, the message box will pop up to show that the cleaning is done.

Figure 12-6 Cleaning Done

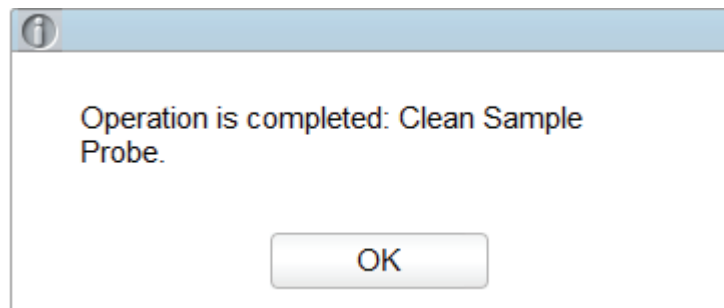

4. Click **OK** to close the message box.
5. Perform the above procedures to clean other components if necessary.

12.2.3 Maintenance

Maintenance of the analyzer includes: unclogging, cleanser soak, cleanser soak for WBC channel, and cleanser soak for RBC channel.

12.2.3.1 Unclogging

If clogging is found, or it is suspected that the counting results are not accurate due to aperture clogging, you can perform the unclogging operations.

The unclogging procedures are shown as follows:

1. Click the **Service** icon in the menu page to access the **Service** interface.

Figure 12-7 Service

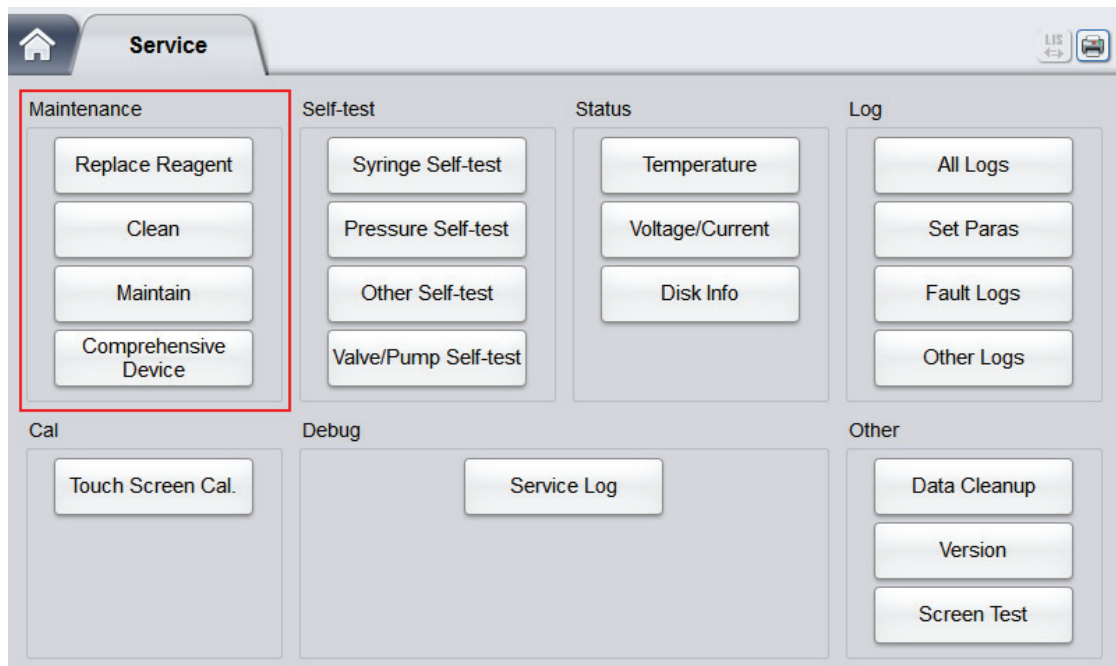

2. Click **Maintain** in the **Maintenance** selection.

The interface as shown in Figure 12-8 will pop up on the screen.

Figure 12-8 Maintenance



3. Click the **Unclog** icon.

The system will start clogging, and a message box will pop up. After the unclogging is completed, a message box will pop up to show that the clogging is done.

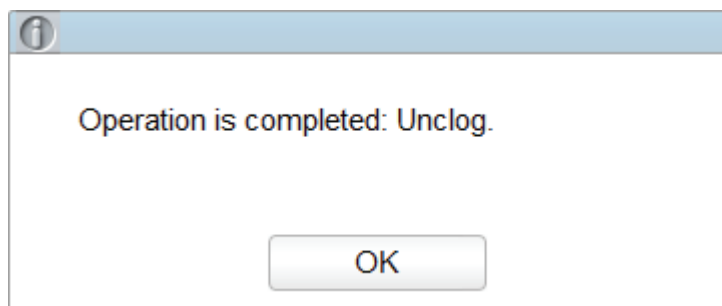

4. Click **OK** to close the message box.
5. Perform the above procedures to continue unclogging if necessary.

12.2.3.2 Cleanser Soak

The cleanser soak should be performed under the following circumstances:

- When the problems including the background results exceed the Ref. Range, bad differential of scattergram and clogging still exist after other maintenance procedures have been adopted.
- Analyzer has been running for more than 24 hours.

The cleanser soak procedures are shown as follows.

1. Click the **Service** icon in the menu page to access the **Service** interface.

Figure 12-9 Service

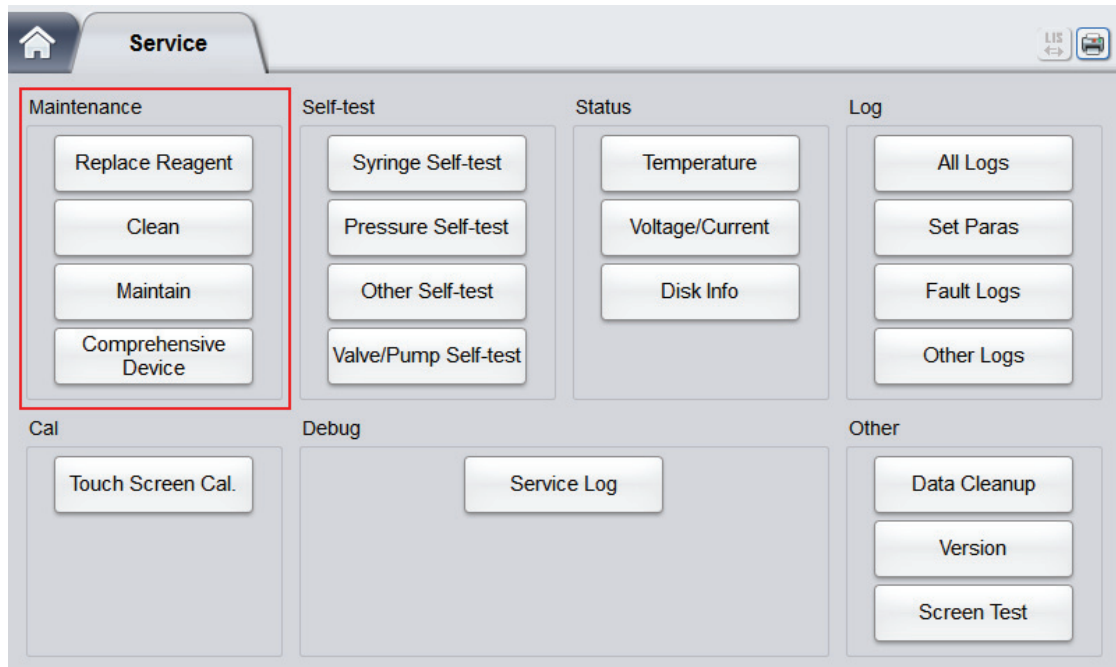

2. Click **Maintain** in the **Maintenance** selection.

The interface as shown in the following picture will pop up on the screen.



3. Click the icon of **Cleanser Soak**.

A dialog box as shown below will pop up.

Figure 12-10 Cleanser Soak

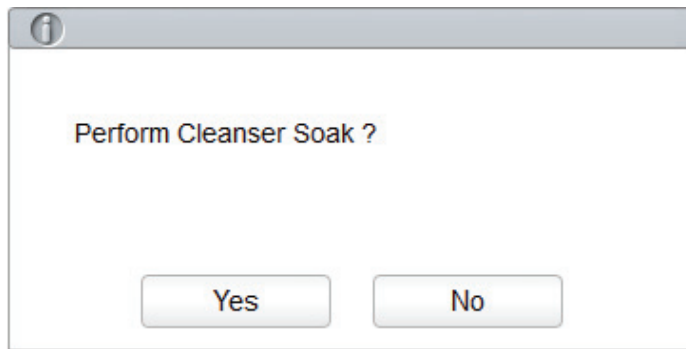

4. Click **Yes**.

A dialog box as shown below will pop up.

Figure 12-11 Cleanser Soak Prompt

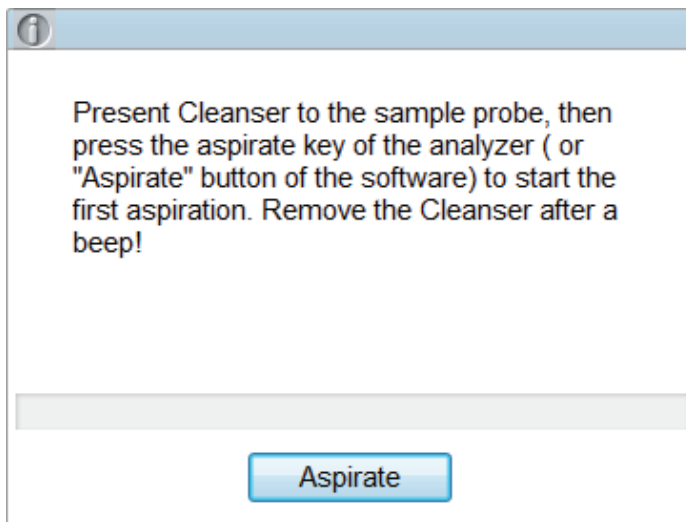

5. Present the cleanser to the sample probe as per the prompt, and press the aspirate key or click the **Aspirate** button.

Cleanser soaking... and the soaking time will appear as shown below. See Figure 12-12. After one minute of soaking, you can stop it manually.

Figure 12-12 Cleanser Soaking Process Prompt

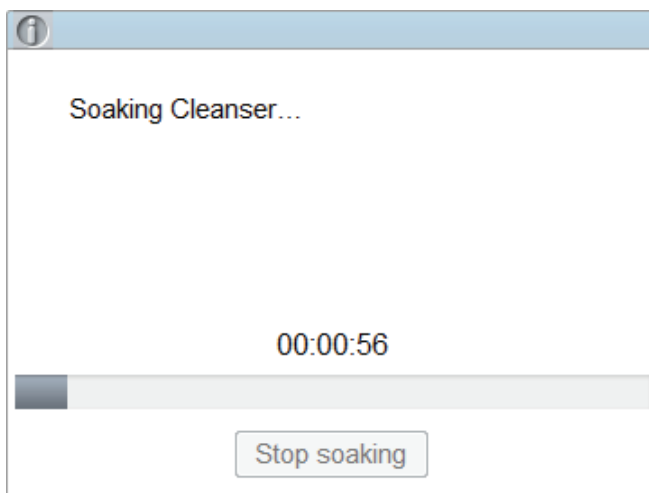

6. Click the **Stop soaking** button, or wait for 19 minutes until the automatic soaking is completed. After the soaking is completed, a prompt **Cleanser Maintenance done!** appears. See Figure 12-13.

Figure 12-13 Cleanser Maintenance Done

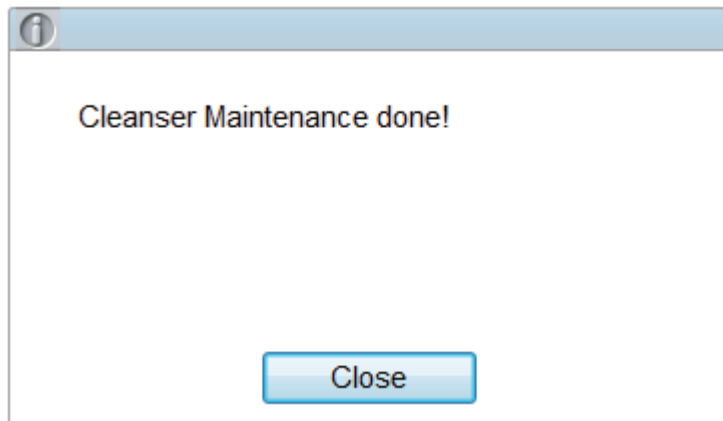

7. Click **Close**.
8. Perform the above procedures to perform the cleanser soak again if necessary.

12.2.3.3 Cleanser Soak for WBC Channel

Probe cleanser soaking for WBC channel can be used to remove the errors for aperture clogging or abnormal scattergram. Please refer to **12.2.3.2 Cleanser Soak** for performing the operations for cleanser soaking for WBC channel.

12.2.3.4 Cleanser Soak for RBC Channel

In case the RBC distribution histogram is abnormal or the clogging is believed to exist in the flow chamber, cleanser soak for RBC channel feature can be used as a means for troubleshooting. Please refer to **12.2.3.2 Cleanser Soak** for performing the operations for cleanser soaking for WBC channel.

12.2.4 Comprehensive Device Maintenance

The comprehensive device maintenance feature includes fluidics initialization, comprehensive device cleaning, emptying fluidics and preparing to ship.

12.2.4.1 Fluidics Initialization

After maintaining the fluidic system or replacing a main part of the analyzer, you should perform this procedure to initialize the fluidic system.

Do as follows to perform the fluidics initialization:

1. Click the **Service** icon in the menu page to access the **Service** interface.

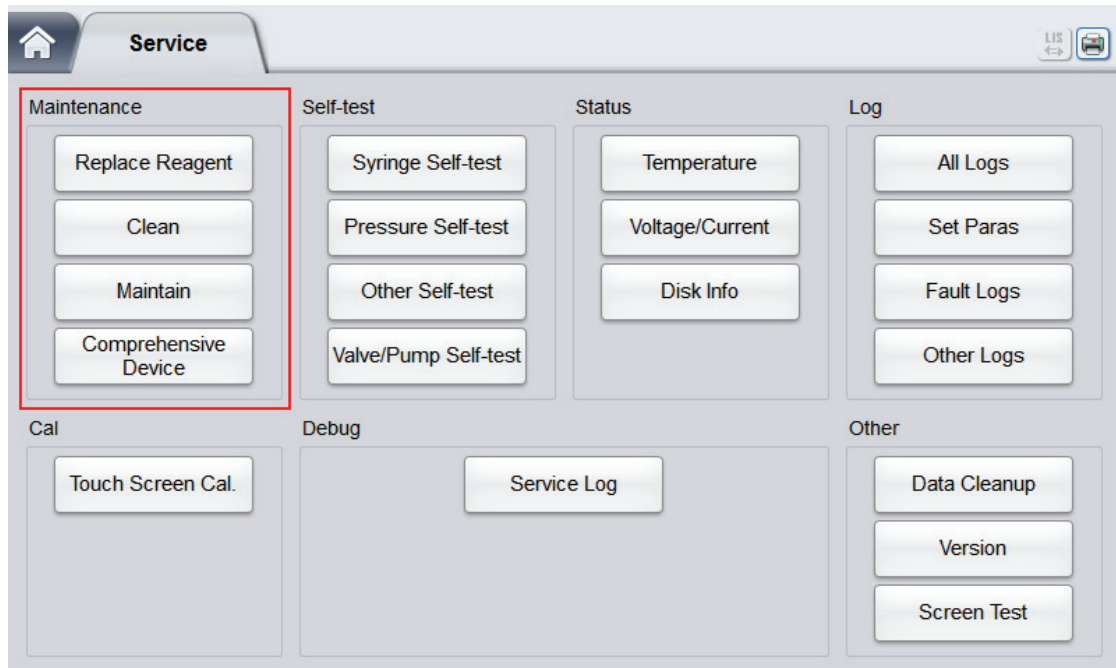

2. Click **Comprehensive Device** in the **Maintenance** selection.
The interface as shown below will pop up on the screen.

Figure 12-14 Comprehensive Device Maintenance

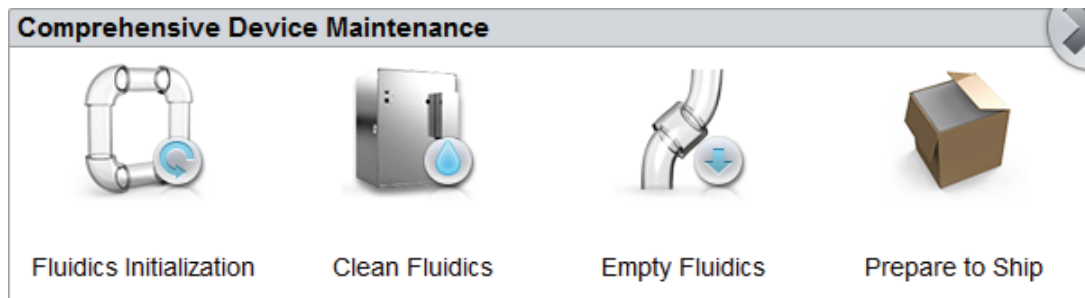

3. Click the icon of **Fluidics Initialization**.
The analyzer starts to perform the fluidics initialization procedure. After the initialization is complete, a message box will pop up.

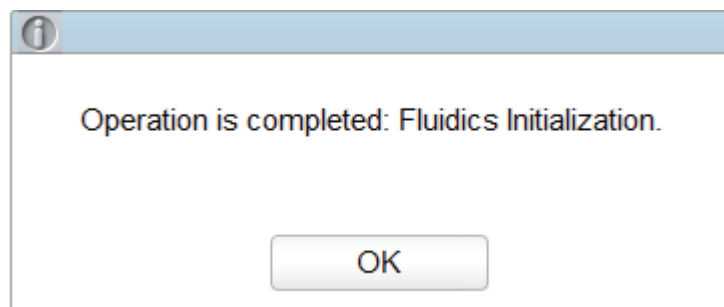

4. Click **OK**.

12.2.4.2 Clean Fluidics

If the background results of parameters are out of the background range, the comprehensive device cleaning should be cleansed.

Procedures for comprehensive device cleaning are shown as below:

1. Click the **Service** icon in the menu page to access the **Service** interface.
2. Click **Comprehensive Device** in the **Maintenance** selection.

The interface as shown below will pop up on the screen.

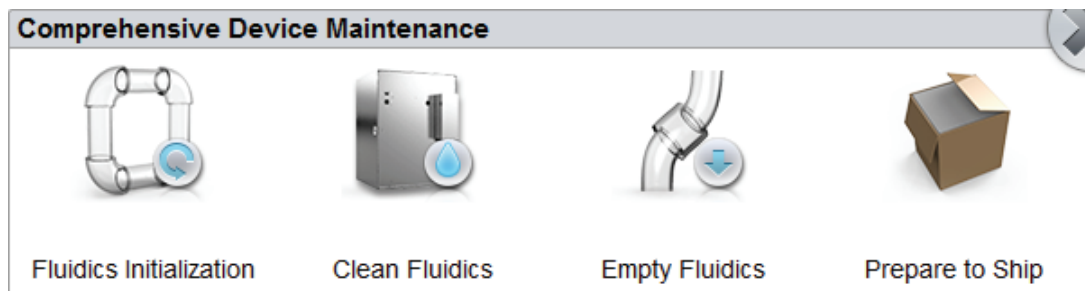

3. Click the icon of Clean Fluidics.

The analyzer starts to perform the fluidics cleaning procedure. After the cleaning is completed, the following message box will pop up.

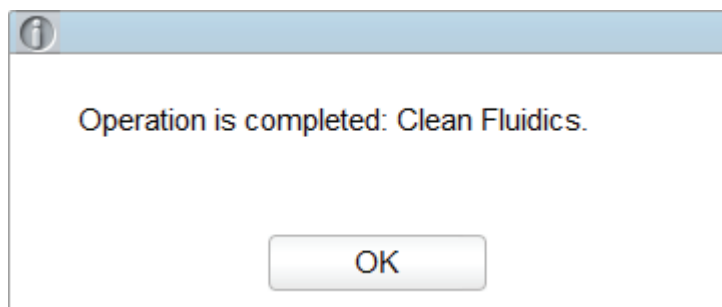

4. Click **OK**.

12.2.4.3 Empty Fluidics

This function enables the device to empty fluidics to prevent crystallization and maintain device performance when the device has not been used for more than one week.

Procedures for emptying fluidics are shown as below:

1. Click the **Service** icon in the menu page to access the **Service** interface.
2. Click **Comprehensive Device** in the **Maintenance** selection.

The interface as shown below will pop up on the screen.

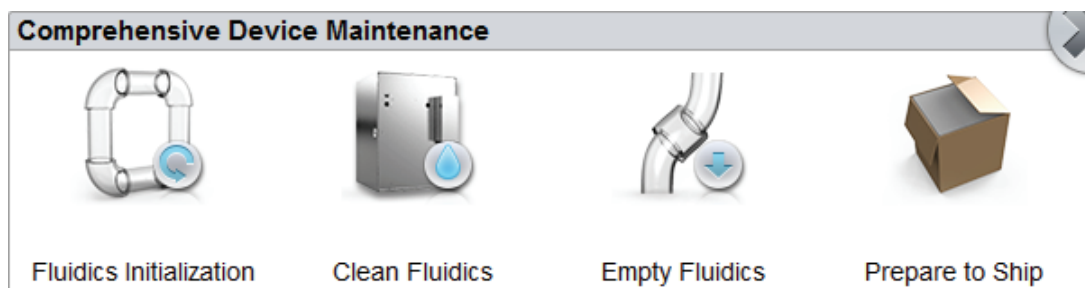

3. Click the icon of Empty Fluidics.

A dialog box will pop up as shown below.

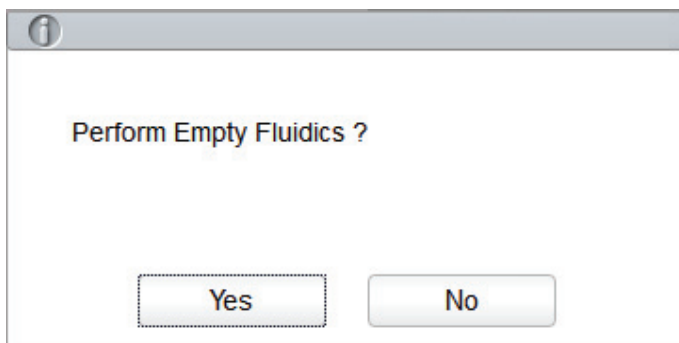

4. Click **Yes**.

A dialog box will pop up as shown below.

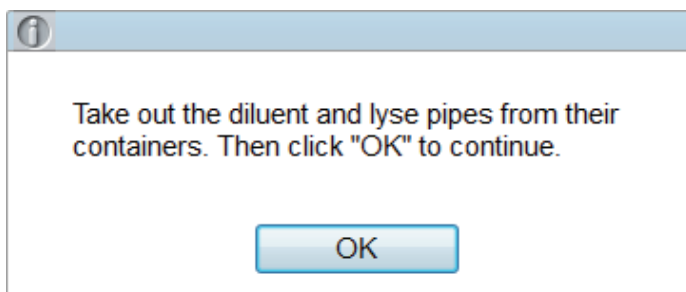

5. Remove all reagent pickup tube assemblies according to the prompt, and then click **OK** to start emptying the fluidic system.

After the emptying is complete, a message box will pop up.

Empty Fluidics done. Please power off the analyzer!

6. Place the [O/I] switch at the left side of the main unit in the [O] position.
7. After shutdown, empty the waste in the waste container, and dispose of it.

WARNING

Be sure to dispose of reagents, waste, samples, consumables, etc. according to local legislations and regulations.

12.2.4.4 Prepare to Ship

If the analyzer is not to be used for over two weeks or needs to be transported over a long distance (transporting time > 2h), you should perform this procedure.

Do as follows to perform the prepare-to-ship procedure:

1. Click the **Service** icon in the menu page to access the **Service** interface.
2. Click **Comprehensive Device** in the **Maintenance** selection.

The interface as shown below will pop up on the screen.

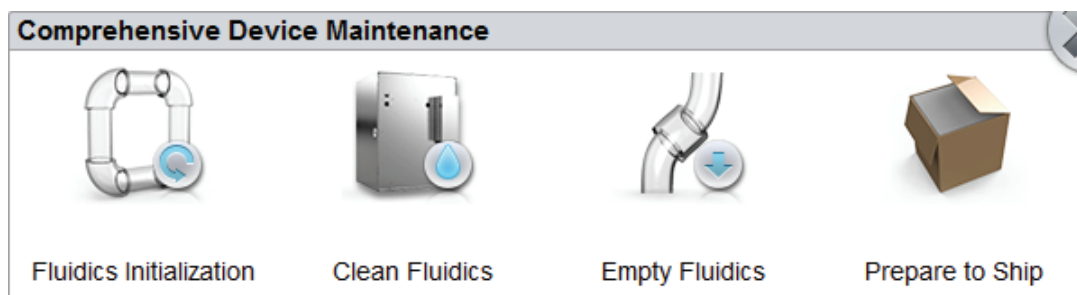

3. Click the icon of **Prepare to Ship**.

A dialog box will pop up as shown below.

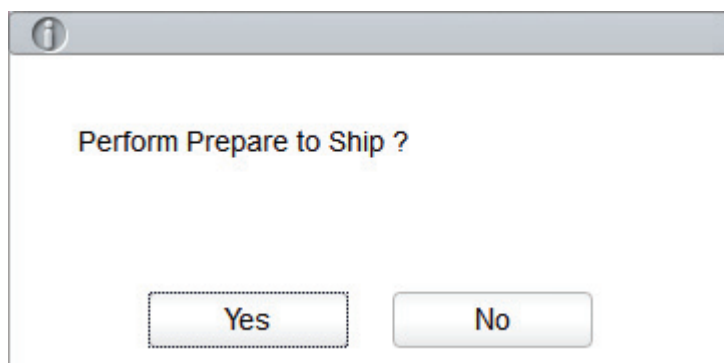

4. Click **Yes**.

The interface pops up a dialog box as shown below.

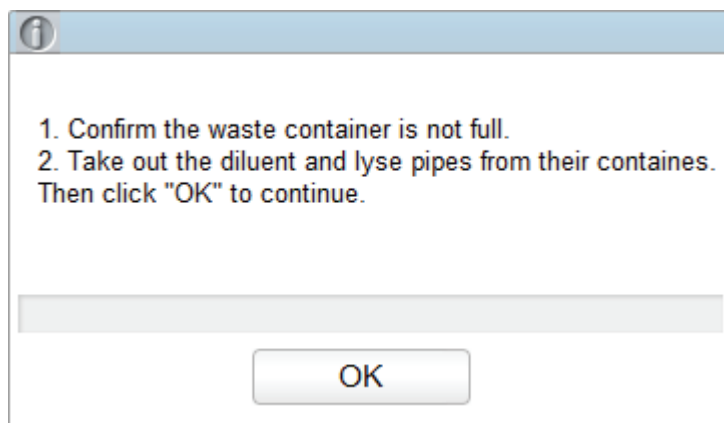

5. Remove all reagent pickup tube assemblies according to the prompt, and then click **OK** to start emptying the fluidic system.

After the emptying is complete, a message box will pop up.

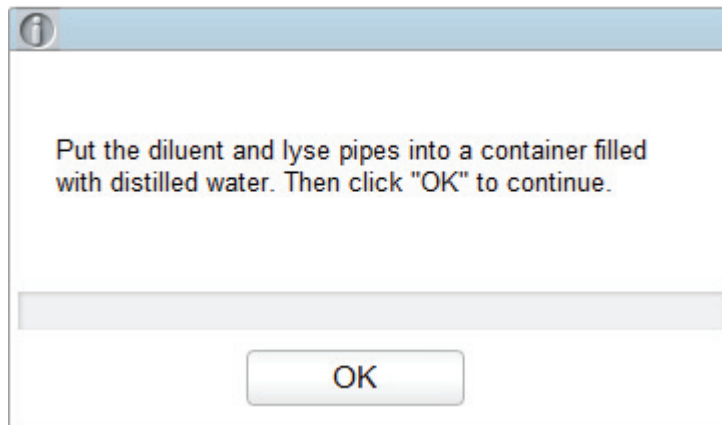

6. Place all reagent pickup tube assemblies into the distilled water, and then click **OK** to start priming.

NOTE

- Be sure to use distilled water in order to ensure the normal use of the device in the future. In addition, the beaker holding the distilled water needs to be cleaned thoroughly.
- The diluent pipe and lyse pipes should be stored separately in two beakers.

System performs the filling operation. After the filling is completed, the following dialog box will pop up.

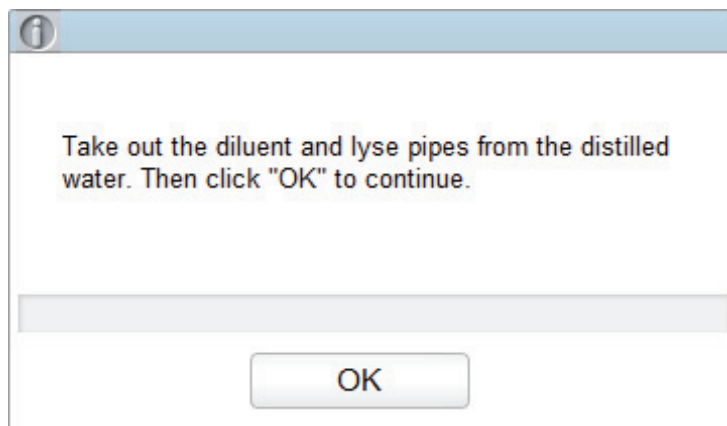

7. Take out the diluent and lyse pipes from the distilled water as per the prompt, then click **OK**. A dialog box will pop up to prompt you to power off the device.

Prepare to Ship done. Please power off the analyzer!

8. Place the [O/I] switch at the left side of the main unit in the [O] position.
9. After shutdown, empty the waste in the waste container, and dispose of it.

**WARNING**

Be sure to dispose of reagents, waste, samples, consumables, etc. according to local legislations and regulations.

12.2.5 Auto Clean

There will be a certain amount of contamination accumulated after running a certain amount of samples without shutting down the analyzer. When the sample count amounts to over 100, the analyzer will perform the cleaning procedure automatically once, and a prompt will be displayed on the screen.

In addition, the analyzer will perform the auto clean procedures if there has been no fluidics sequential operation for more than one hour.

NOTE

Once the auto clean is performed or the analyzer is shut down, the statistical data of auto clean will be cleared automatically.

12.2.6 Auto Prompt for Cleanser Soak

After the analyzer starts up and when the preset conditions for prompting auto maintenance are met, the system will prompt to perform cleanser soak immediately, so as to prevent the accumulation of contamination.

- If “Prompt according to the time” is set for the auto cleanser soak, when the preset prompt time is reached and cleanser soak has not been performed for the current day, the system will prompt to perform cleanser soak immediately.
- If “Prompt according to the sample numbers” is set for the auto cleanser soak, when the total number of samples in the system reaches the preset total number of samples or it has been 24 hours since the last cleanser soak, the system will prompt to perform cleanser soak immediately.

When the system prompts to perform cleanser soak immediately, you can choose to perform operation according to actual needs.

- Click **Yes**, then you can perform the cleanser maintenance as per the prompt and the description in **12.2.3.2 Cleanser Soak**.
- Click **No**, the cleanser maintenance will be cancelled temporarily. You will be reminded after 10 minutes and you can cancel 3 times at most. When the system reminds the fourth time, you must perform the maintenance, otherwise the normal operation of the analyzer may be affected.

NOTE

- For the auto prompt time and wait time of cleanser soak, please refer to 5.3.4 Auto Maintenance.
 - At the **Calibrator calibration** or **Fresh blood calibration** interface, the analyzer does not ask for confirmation to perform the cleanser soak.
 - If the analyzer is running or has problems when the conditions of auto prompt for cleanser soak is satisfied, the analyzer will prompt again after the current operation is completed or the problems are resolved.
 - If the analyzer is in the sleep mode when the conditions of auto prompt for cleanser soak are met, the analyzer will prompt after exiting the sleep mode.
 - After cleanser soak is completed, the accumulative count values will be cleared automatically. The time interval since the last cleanser soak will be cleared automatically.
 - Cleanser soak is an important step in comprehensive device maintenance. It is recommended not to stop soaking halfway.
-

12.2.7 Auto Sleep

When the fluidics system stops working for a specified waiting time for auto sleeping (30 minutes by default), the analyzer will enter the sleeping status automatically. You can change the waiting time for auto sleeping as needed, see **5.3.4 Auto Maintenance**.

When the analyzer is in the sleep mode, a prompt will be displayed on the screen. Touch the screen or press the aspirate key on the analyzer to wake it up.

NOTE

- If it is the time to auto sleep but the analyzer is error status, then only after the error is removed will auto sleep start accordingly.
 - Different maintenances will be performed by the analyzer automatically when exiting the sleep mode, and the exiting time depends on how long the analyzer was in the sleep mode.
 - If errors occur when you are trying to cancel the auto sleep of the analyzer, please refer to **13 Troubleshooting** for solving the problems.
-

12.3 Self-test

This feature is to test if some important components of the device can function properly or not, including syringe and sampling assembly self-test, pressure and vacuum self-test, valve self-test and other self-test.

NOTE

If the testing result is abnormal, you should try again for several times; if the abnormalities persist, please contact Dymind customer service department or your local agent.

12.3.1 Syringe and Sampling Mechanism

You can test the performance of all syringes and sampling mechanisms.

The self-inspection procedures are shown as below:

1. Click the **Service** icon in the menu page to access the **Service** interface.
2. Click **Syringe Self-test** in the **Self-test** selection.

The interface as shown in Figure 12-15 will pop up on the screen.

Figure 12-15 Syringe

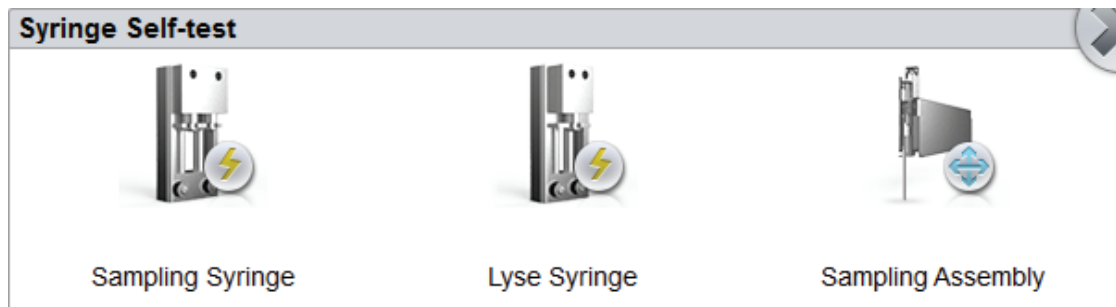

3. Click the part that needs to be tested, e.g. **Sampling Syringe**, and wait for the self-inspection results.

After the self-test is completed, a dialog box will pop up to show the self-test results.

Figure 12-16 Syringe Self-test Results

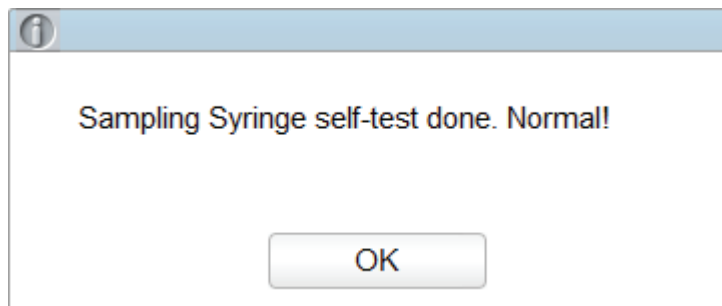

4. Click **OK** to close the message box.

12.3.2 Pressure and Vacuum

This feature is to test the pressure and vacuum inside the device.

Procedures for pressure (or vacuum) self-inspection are shown as below:

1. Click the **Service** icon in the menu page to access the **Service** interface.
2. Click **Pressure Self-test** in the **Self-test** selection.

The interface as shown in Figure 12-17 will pop up on the screen.

Figure 12-17 Pressure and Vacuum Self-inspection

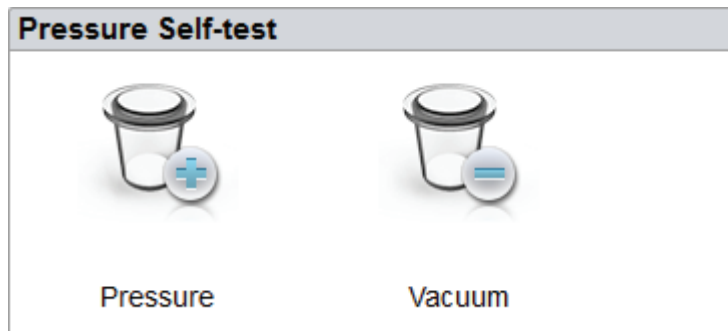

3. Click **Pressure** (or **Vacuum**).

The system will perform the corresponding self-test operations. After the self-test is completed, a dialog box will pop up to show the self-test results.

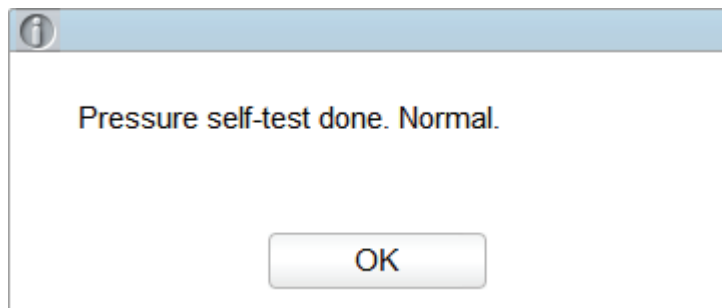

4. Click **OK** to close the message box.

12.3.3 Valve & Pump

When controlling the switches of different valves (pumps), you can judge if the valves (pumps) are operating properly by the sound of opening, closing or manually touching the corresponding valves (pumps).

The procedures for valve self-inspection are shown as follows:

1. Click the **Service** icon in the menu page to access the **Service** interface.
2. Click **Valve/Pump Self-test** in the **Self-test** selection.

The interface as shown in Figure 12-18 will pop up on the screen.

Figure 12-18 Valve/Pump Self-test

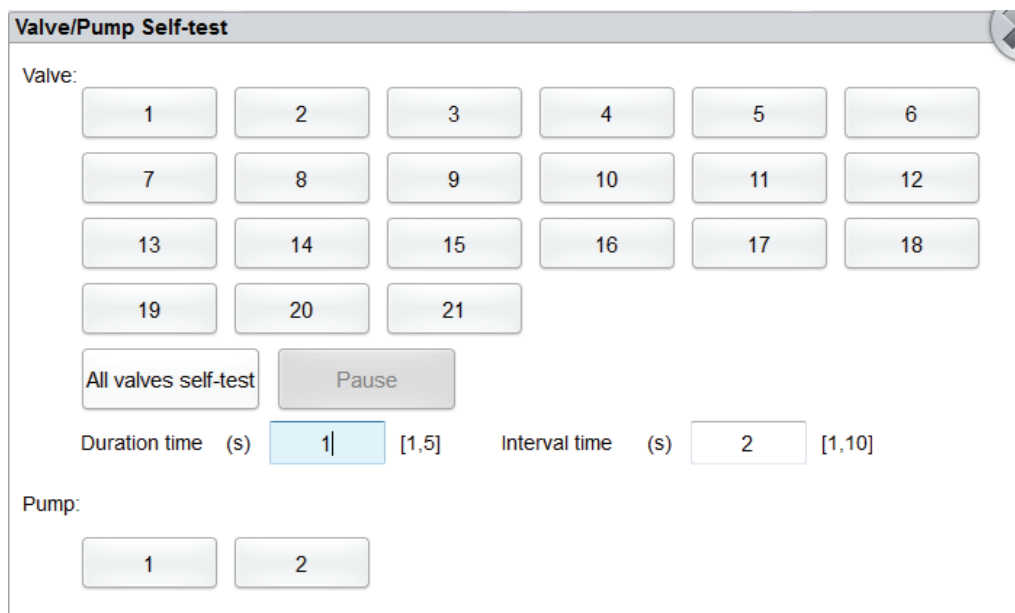

Single Valve/Pump Self-Test

Click the desired valve number (e.g. 1), then confirm whether it works properly by the sound of its opening and closing.

All Valves Self-Test

1. In the “Duration time” edit box, the administrator can set the time of opening and closing for the valve. The acceptable value ranges from 1s to 5s. The default value is 1s.
2. In the “Interval time” edit box, the administrator can set the interval time of valve self-test. The acceptable value ranges from 1s to 10s. The default value is 2s.
3. Click “All valves self-test”, all the valves will be automatically self-tested from small to large according to valve No.
4. During the self-test, click “Pause” and all the valves are closed; click “Restore” and the self-test operation for all the valves are restored.

12.3.4 Others

You can perform the self-test for RBC aperture voltage.

RBC Aperture Voltage

The self-test procedure of RBC aperture voltage is shown as below:

1. Click the **Service** icon in the menu page to access the **Service** interface.
2. Click **Other Self-test** in the **Self-test** selection.

The interface as shown in Figure 12-19 will pop up on the screen.

Figure 12-19 Other Self-test

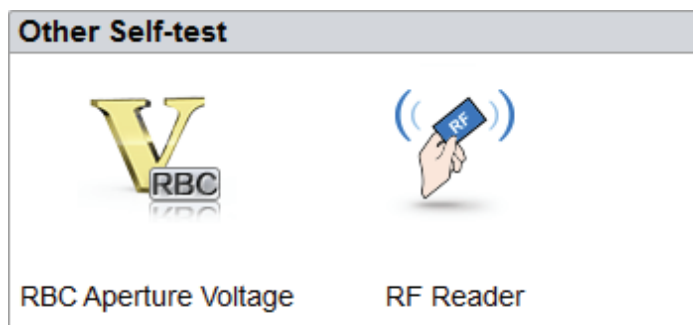

3. Click **RBC Aperture Voltage** to start self-test.

The system will perform the corresponding self-test operations. After the self-inspection is completed, a dialog box will pop up to show the self-inspection results.

RF Card Reader (for a closed system)

The self-test procedures of RF card reader are as follows:

1. Click the **Service** icon in the menu page to access the **Service** interface.
2. Click **Other Self-test** in the **Self-test** selection.
3. Click the icon of **RF Reader** to start self-test.

A dialog box will pop up as shown below.

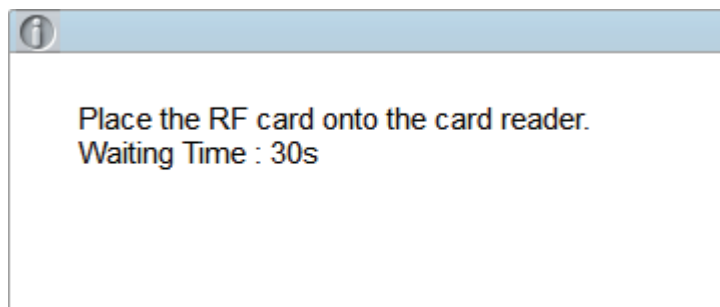

4. According to the interface prompt, put the RF card on the card reader in front of the analyzer.
The system will perform the corresponding self-test operations. After the self-inspection is completed, a dialog box will pop up to show the self-inspection results.
5. Click **OK** to close the message box.

12.4 System Status

You can view the current status information of the analyzer in the **Status** selection, including temperature, voltage and current, and version information.

12.4.1 Temperature

1. Click the **Service** icon in the menu page to access the **Service** interface.
2. Click **Temperature** in the **Status** selection.

The interface as shown in Figure 12-20 will pop up on the screen.

Figure 12-20 View Temperature Status

Temperature	
Preheating bath temperature	50.1 [48.5, 51.5]
Ambient Temperature	29.9 [15.0, 30.0]
Optical System Temperature	34.9 [30.0, 40.0]

User can view the current temperature information of the analyzer, including the temperature of preheating bath temperature, ambient temperature and the temperature of the optical system. If the results of the temperature testing exceed the normal range, they will be highlighted by the red background.

12.4.2 Voltage and Current

1. Click the **Service** icon in the menu page to access the **Service** interface.
2. Click **Voltage/Current** in the **Status** selection.

The interface as shown below will pop up on the screen.

Figure 12-21 Voltage and Current

Voltage/Current	
Voltage (V)	
P12V	P24V
12 [10.0, 15.0]	24 [20.0, 28.0]
A+12V	A-12V
12 [10.0, 15.0]	-12 [-15.0, -10.0]
Constant Current Source Voltage	HGB Blank Voltage:
56 [50.0, 75.0]	4.5 [4.2, 4.8]
Current (mA)	
Laser Diode Current	
24	

You can view the voltage and current information of the analyzer. The voltage or current value that exceeds the normal range will be displayed in a red background.

12.4.3 Disk Information

You can view the disk information of the analyzer, including disk name, capacity and used space. Specific steps are shown below.

1. Click the **Service** icon in the menu page to access the **Service** interface.
2. Click **Disk Info** in the **Status** selection.

The disk information interface displays. See Figure 12-22.

Figure 12-22 Disk Information

Item	Capacity	Used space
Flash	501.5M	0%
SD card	7.3G	6%

12.5 Log

In the Log interface, you can view the records of **Set Paras**, **Other Logs**, **Fault Logs** and **All Logs**.

NOTE

- If a new record is added when the log is full, the newest record will overwrite the oldest one automatically.
- The administrator can view both his/her own operation logs and the general users' operation logs, while the general users can only review their own operation logs.
- The log can keep records of up to 5 years.

12.5.1 All Logs

1. Click the **Service** icon in the menu page to access the **Service** interface.
2. Click **All Logs** in the **Log** selection.

You can view all logs (visible to the users of the current access level).

Figure 12-23 All Logs

All Logs

2022/11/04 -- 2022/11/04 All Logs

No.	Time	Summary Information	Details	Operator
1	2022/11/04 16:01:08	Report Error	0xb2004001 : Background abnor...	Administrator a...
2	2022/11/04 16:01:08	Run	Background Count mode countin...	Administrator a...
3	2022/11/04 16:01:05	Run	Background Count mode countin...	Administrator a...
4	2022/11/04 16:00:59	Startup	Startup	Administrator a...
5	2022/11/04 16:00:55	Login	admin(admin) Login	Administrator a...
6	2022/11/04 15:10:21	Report Error	0xb2004001 : Background abnor...	Administrator a...
7	2022/11/04 15:10:21	Run	Background Count mode countin...	Administrator a...
8	2022/11/04 15:10:18	Run	Background Count mode countin...	Administrator a...
9	2022/11/04 15:10:12	Startup	Startup	Administrator a...
10	2022/11/04 15:10:07	Login	admin(admin) Login	Administrator a...

Date and Time:2022/11/04 15:10:21
 Operator:Administrator admin (admin)
 Summary Information:Report Error
 Details:0xb2004001 : Background abnormal.

3. Select the dates in the two date textboxes, and then you can view the all logs within the date range, including operation time, log information and the operator.

NOTE

You can also click the drop-down list of log type on the right of the date edit box, and select **Reagent Logs** to review the log records for all the reagent replacement within the current date range.

12.5.2 Parameter Revision Logs

1. Click the **Service** icon in the menu page to access the **Service** interface.
2. Click **Set Paras** in the **Log** selection.

You can view the parameter revision logs (which can be viewed by the user with the current level of access) within a specified date range.

3. Select the dates in the two date textboxes, and then you can view the fault logs within the date range, including date and time when the faults occur, fault description and the operator.

12.5.4 Other Logs

1. Click the **Service** icon in the menu page to access the **Service** interface.
2. Click **Other Logs** in the **Log** selection.

You can view other logs besides parameter revision logs and fault logs.

Figure 12-26 Other Logs

Other Logs				
2018/10/22		2018/10/22		
No.	Time	Summary Information	Details	Operator
1	2018/10/22 10:45:36	Run	Background Count mode countin...	Administrator a...
2	2018/10/22 10:45:33	Run	Background Count mode countin...	Administrator a...
3	2018/10/22 10:45:27	Startup	Startup	Administrator a...
4	2018/10/22 10:45:21	Login	admin(admin) Login	Administrator a...
5	2018/10/22 10:15:01	Run	Background Count mode countin...	Administrator a...
6	2018/10/22 10:14:57	Run	Background Count mode countin...	Administrator a...
7	2018/10/22 10:14:52	Startup	Startup	Administrator a...
8	2018/10/22 10:14:47	Login	admin(admin) Login	Administrator a...
Date and Time:2018/10/22 10:45:36 Operator:Administrator admin (admin) Summary Information:Run Details:Background Count mode counting run successfully				

3. Select the dates in the two date textboxes to view the logs within the date range, including operation date and time, operation records and the operator.

12.6 Data Cleanup

You can clean up the data stored in the analyzer. Specific steps are shown below.

1. Click the **Service** icon in the menu page to access the **Service** interface.
2. Click **Data Cleanup** in the **Other** selection.

The data cleanup interface displays. See Figure 12-27.

Figure 12-27 Data Cleanup

Data Cleanup

Time range

Start Time: System installed date

End time: 2018/07/20

Data

Counting result Core files

L-J QC results Scattergram

X-B QC results

Log files

Apply OK Cancel

3. Click the **End time** combo box, set the date range of the data to be cleaned up in the popup dialog box.

yyyy/MM/dd

2018 07 20

OK Cancel

- The input sequence of the controls is the same with the date format on the top right corner of the dialog box. For example, if the data format is **yyyy/MM/dd**, you should input the data in the sequence of year, month, and date.
- Click ▲ or ▼ to select a date and time or enter the information in the textbox directly.
- Click  to clear the data and input again.

For example, If the **End time** is set to **2016/03/31**, the data generated from system installation date to 31 March 2016 will be cleared.

4. Click **OK** to save the settings and close the dialog box.
5. Select the data to be cleaned up.

You can clean up the following data:

- Counting results
- L-J QC results

- X-B QC results
 - Log files
 - Core files
 - Scattergram
6. Click **Apply** or **OK**.

The interface pops up a dialog box as shown below, indicating the cleanup is completed.

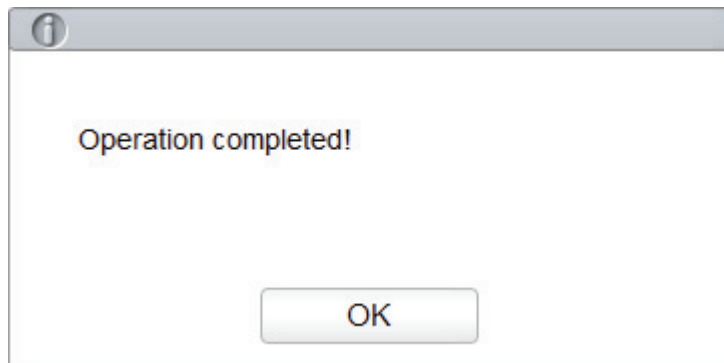

12.7 Version Information

You can view the current version information of all parts of the analyzer, and export the version information to a USB flash disk. Detailed steps are shown below:

1. Click the **Service** icon in the menu page to access the **Service** interface.
2. Click **Version** In the **Other** selection.

Version information interface will pop up on the screen. See Figure 12-28.

Figure 12-28 Version Information

Software Full Version	0.5.20.13902	Software Release Version	5
Technical File Version		Machine Type	1104
Application Software		Algorithm	1.4.21.20161110
Boot Software	0.11.9.0	MLO	0.11.9.0
MCU	0.0.0.0	FPGA	0.0.0.0
Fluidics Sequence	0.1.9.5	Operating System	3.2.0.0
LIBS		RF Reader MCU	0.0.0.0

Export

3. Insert a USB flash disk in the USB interface on the analyzer.
4. Click **Export**, and select the export path in the dialog box, and then enter the file name.
The file will be exported to the root directory of the USB flash disk (**/udisk/sda1**) by default as shown below.

Export

/udisk/sda1

SampleInfo.csv

Version_20150817_20150817.csv

Csv File(*.csv)

Save Cancel

5. Click **Save** to start exporting.

After Export is completed, the message box as shown below will pop up.

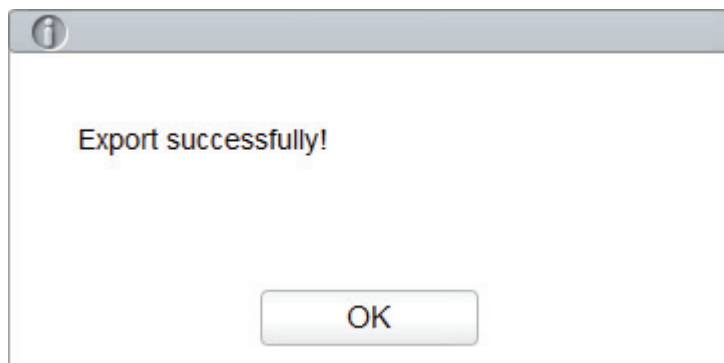

6. Click **OK** to exit.

12.8 Touch Screen Calibration

When the touch screen has offset, it needs to be recalibrated. Detailed steps are shown below:

1. Click the **Service** icon in the menu page to access the **Service** interface.
2. Click **Touch Screen Cal.** in the **Cal** selection.
3. Click the calibration point "+" on the screen in order.

When the calibration point disappears and the system return to the service screen, it indicates the completion of the calibration.

12.9 Screen Test

You can run a screen test to detect dead pixel or stuck pixel on the touch screen. Detailed steps are shown below:

1. Click the **Service** icon in the menu page to access the **Service** interface.
2. Click **Screen Test** in the **Other** selection to enter the touch screen test interface.



3. Find out if there are any dead pixels on the screen, touch the screen to change the color and continue to check.

When the interface disappears and returns to the **Service** interface, the screen test is complete. If there are dead pixels on the screen, contact our customer service department for maintenance and handling.

12.10 Downloading Service Logs

In the use of the analyzer, when errors occur and can not be removed, it's recommended that you export the service logs file to a USB flash disk and send the file to Dymind customer service engineer. Specific steps are shown below.

1. Insert a USB flash disk into the USB interface on the analyzer.
2. Click the **Service** icon in the menu page to access the **Service** interface.
3. Click **Service Log** in the **Debug** selection.
4. Select the data range of the logs to be exported in the pop-up dialog box. See Figure 12-29.

Figure 12-29 Downloading Service Logs

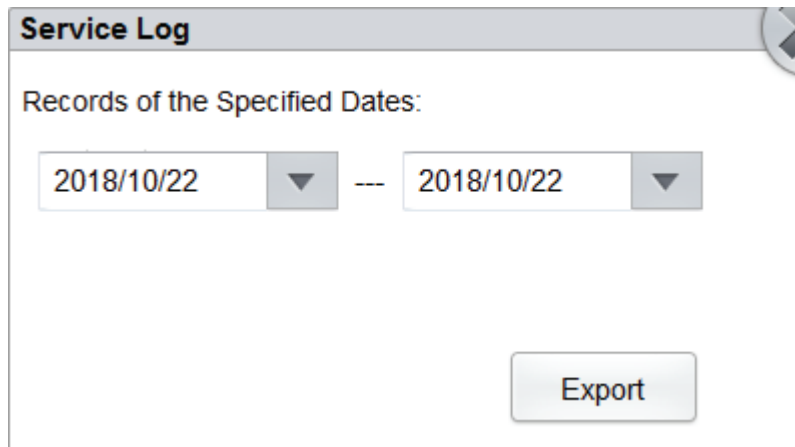

5. Click **Export**.

The **host_download.tar** file is exported to the root directory of the USB flash disk, and a message box is shown below.

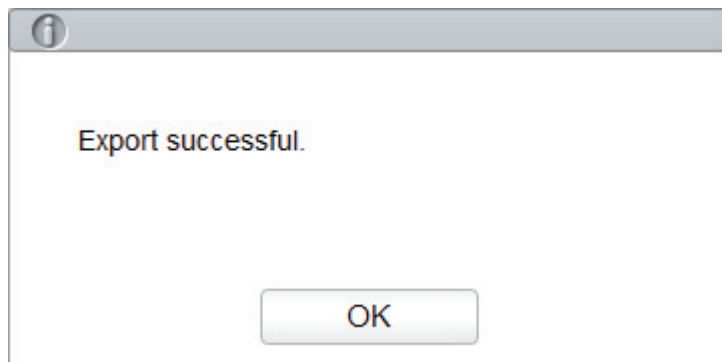

6. Send the **host_download.tar** file to our customer service engineer.

13 Troubleshooting

13.1 Introduction

This chapter contains information that is helpful in locating and resolving problems that may occur during the operation of your analyzer.

NOTE

This chapter is not a complete service manual and is limited to problems that are readily diagnosed and/or corrected by the user of the analyzer. If the recommended solution fails to solve the problem, contact Dymind customer service department or your local agent.

13.2 Dealing with Error Messages

In the use of the analyzer, when the software detects abnormalities, an error message will be displayed on the upper right of the screen as shown in Figure 13-1 and the main unit will sound an alarm.

Figure 13-1 Error Messages

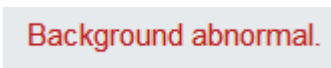
A screenshot of an error message displayed on a screen. The text "Background abnormal." is shown in a red font on a light gray rectangular background.

You can refer to the following steps to deal with the error messages.

1. Click the error message area.

As shown in Figure 13-2, the popup dialog box displays the error description and its help information. The error descriptions are displayed in the order of error occurrence.

Figure 13-2 Error Message Dialog Box

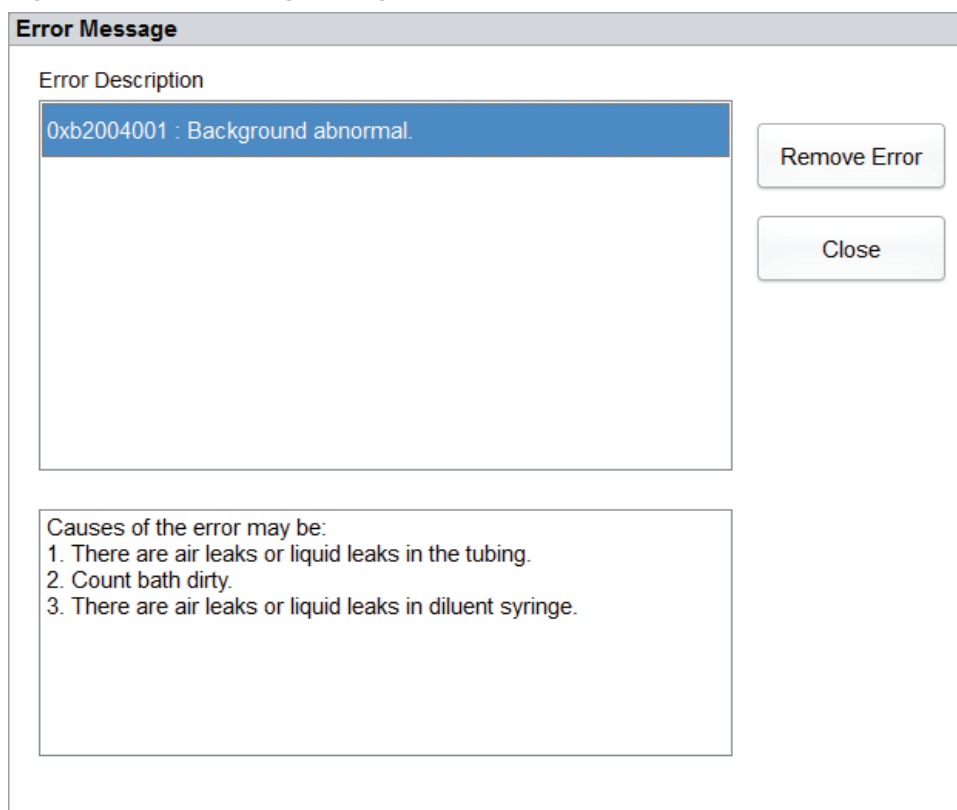

2. Touch the screen to disable the beep.
3. Click **Remove Error**.

Normally, the system will automatically remove the errors.

For errors which cannot be removed automatically, you can take appropriate actions by following the error help information or **13.3 Error Message Reference**.

13.3 Error Message Reference

Possible errors and the corresponding help information are shown in Table 13-1.

Table 13-1 Error Message Reference

Problem Name	Troubleshooting Information
Positive 12V power abnormal.	<ol style="list-style-type: none"> 1. Please turn off the analyzer power directly and restart later. 2. If the error still exists, contact our customer service department.
Optical assembly cover open.	<ol style="list-style-type: none"> 1. Close the optical assembly cover. 2. If the error still exists, contact our customer service department.
Constant current source voltage abnormal.	<ol style="list-style-type: none"> 1. Please turn off the analyzer power directly and restart later. 2. If the error still exists, contact our customer service department.
Laser current abnormal.	<ol style="list-style-type: none"> 1. Please turn off the analyzer power directly and restart later. 2. If the error still exists, contact our customer service department.

Problem Name	Troubleshooting Information
Startup process failed.	<ol style="list-style-type: none"> 1. Click the Remove Error button to remove this error. 2. If the error still exists, contact our customer service department.
Startup initialization not executed.	<ol style="list-style-type: none"> 1. Click the Remove Error button to remove this error. 2. If the error still exists, contact our customer service department.
The right-side door open.	<ol style="list-style-type: none"> 1. Close the right side door. 2. Click the Remove Error button to remove this error. 3. If the error still exists, contact our customer service department.
Positive 12V power abnormal.	<ol style="list-style-type: none"> 1. Please turn off the analyzer power directly and restart later. 2. If the error still exists, contact our customer service department.
DIL-C expired.	<ol style="list-style-type: none"> 1. Check if the DIL-C diluent is expired. If so, change a new container of DIL-C. 2. Click the Remove Error button, the Reagent Management screen will pop up. 3. Set the reagent information by referring to 11 Reagent Management. 4. If the error still exists after a new container of DIL-C is installed, contact our customer service department.
LYC-1 expired.	<ol style="list-style-type: none"> 1. Check if the LYC-1 lyse is expired. If so, change a new container of LYC-1. 2. Click the Remove Error button, the Reagent Management screen will pop up. 3. Set the reagent information by referring to 11 Reagent Management. 4. If the error still exists after a new container of LYC-1 is installed, contact our customer service department.
LYC-2 expired.	<ol style="list-style-type: none"> 1. Check if the LYC-2 lyse is expired. If so, change a new container of LYC-2. 2. Click the Remove Error button, the Reagent Management screen will pop up. 3. Set the reagent information by referring to 11 Reagent Management. 4. If the error still exists after a new container of LYC-2 is installed, contact our customer service department.
Preheating bath temperature out of working range.	<ol style="list-style-type: none"> 1. Click the Remove Error button to remove this error. 2. If the error still exists, contact our customer service department.
HGB background voltage abnormal.	<ol style="list-style-type: none"> 1. Adjust the HGB background voltage within the specified range (4.2V~4.8V), preferably 4.5V. Refer to 5.5.1 Gain Settings. 2. If the error still exists, contact our customer service department.
RBC aperture voltage abnormal.	<ol style="list-style-type: none"> 1. Click the Remove Error button to remove this error. 2. If the error still exists, contact our customer service department.

Problem Name	Troubleshooting Information
Background abnormal.	<ol style="list-style-type: none"> 1. Check whether the diluent is contaminated. 2. If not, click the Remove Error button to remove the error. 3. If the error still exists, contact our customer service department.
Failed to read sampling syringe parameter.	<ol style="list-style-type: none"> 1. Click the Remove Error button to remove this error. 2. If the error still exists, contact our customer service department.
Failed to configure sampling syringe parameter.	<ol style="list-style-type: none"> 1. Click the Remove Error button to remove this error. 2. If the error still exists, contact our customer service department.
Sampling syringe action overtime.	<ol style="list-style-type: none"> 1. Click the Remove Error button to remove this error. 2. If the error still exists, contact our customer service department.
Sampling syringe busy.	<ol style="list-style-type: none"> 1. Click the Remove Error button to remove this error. 2. If the error still exists, contact our customer service department.
Failed to read LYSE syringe parameter.	<ol style="list-style-type: none"> 1. Click the Remove Error button to remove this error. 2. If the error still exists, contact our customer service department.
Failed to configure LYSE syringe parameter.	<ol style="list-style-type: none"> 1. Click the Remove Error button to remove this error. 2. If the error still exists, contact our customer service department.
LYSE syringe action overtime.	<ol style="list-style-type: none"> 1. Click the Remove Error button to remove this error. 2. If the error still exists, contact our customer service department.
LYSE syringe busy.	<ol style="list-style-type: none"> 1. Click the Remove Error button to remove this error. 2. If the error still exists, contact our customer service department.
Vertical motor instruction parameter error.	<ol style="list-style-type: none"> 1. Click the Remove Error button to remove this error. 2. If the error still exists, contact our customer service department.
Failed to read vertical motor parameter.	<ol style="list-style-type: none"> 1. Click the Remove Error button to remove this error. 2. If the error still exists, contact our customer service department.
Vertical motor action overtime.	<ol style="list-style-type: none"> 1. Click the Remove Error button to remove this error. 2. If the error still exists, contact our customer service department.
Failed to read the remaining steps of vertical motor.	<ol style="list-style-type: none"> 1. Click the Remove Error button to remove this error. 2. If the error still exists, contact our customer service department.
Vertical motor busy.	<ol style="list-style-type: none"> 1. Click the Remove Error button to remove this error. 2. If the error still exists, contact our customer service department.
Failed to read preheating bath temperature.	<ol style="list-style-type: none"> 1. Make sure the temperature sensor is correctly installed. 2. If the error still exists, contact our customer service department.
Failed to read optical system temperature.	<ol style="list-style-type: none"> 1. Make sure the temperature sensor is correctly installed. 2. If the error still exists, contact our customer service department.

Problem Name	Troubleshooting Information
Failed to read ambient temperature.	<ol style="list-style-type: none"> 1. Make sure the temperature sensor is correctly installed. 2. If the error still exists, contact our customer service department.
Waste is full.	<ol style="list-style-type: none"> 1. Empty the waste container or install a new waste container. 2. Click the Remove Error button to remove this error. 3. If the error still exists, contact our customer service department.
The setting temperature of optical system out of range.	<ol style="list-style-type: none"> 1. Click the Remove Error button to remove this error. 2. If the error still exists, contact our customer service department.
Optical system temperature out of working range.	<ol style="list-style-type: none"> 1. Click the Remove Error button to remove this error. 2. If the error still exists, contact our customer service department.
Flow cell clog.	<ol style="list-style-type: none"> 1. Click the Remove Error button to remove this error. 2. If the error still exists, contact our customer service department.
Failed to read horizontal motor parameter.	<ol style="list-style-type: none"> 1. Click the Remove Error button to remove this error. 2. If the error still exists, contact our customer service department.
Failed to configure Horizontal motor parameter.	<ol style="list-style-type: none"> 1. Click the Remove Error button to remove this error. 2. If the error still exists, contact our customer service department.
Horizontal motor action overtime.	<ol style="list-style-type: none"> 1. Click the Remove Error button to remove this error. 2. If the error still exists, contact our customer service department.
Horizontal motor photocoupler abnormal.	<ol style="list-style-type: none"> 1. Click the Remove Error button to remove this error. 2. If the error still exists, contact our customer service department.
Horizontal motor busy.	<ol style="list-style-type: none"> 1. Click the Remove Error button to remove this error. 2. If the error still exists, contact our customer service department.
DIL-C running out.	<ol style="list-style-type: none"> 1. Check whether the DIL-C container is empty. If so, perform step 2. Or if there is still plenty of diluent, make sure the diluent float sensor is placed correctly, then perform step 3. 2. Install a new container of diluent. Then set the reagent information by referring to 11 Reagent Management. 3. Click the Remove Error button to remove the error. 4. If the error still exists, contact our customer service department.
LYC-1 running out or air bubbles in inlet tubing.	<ol style="list-style-type: none"> 1. Check whether the LYC-1 is running out or there are air bubbles in the inlet tubing of LYC-1. If so, perform step 2; or if there is still plenty of LYC-1, contact our customer service department. 2. Install a new container of LYC-1. Then click the Remove Error button to remove the error. 3. If the error still exists after a new container of LYC-1 is installed, contact our customer service department.

Problem Name	Troubleshooting Information
LYC-2 running out or air bubbles in inlet tubing.	<ol style="list-style-type: none"> 1. Check whether the LYC-2 is running out or there are air bubbles in the inlet tubing of LYC-2. If so, perform step 2; or if there is still plenty of LYC-2, contact our customer service department. 2. Install a new container of LYC-2. Then click the Remove Error button to remove the error. 3. If the error still exists after a new container of LYC-2 is installed, contact our customer service department.
DIL-C not replaced.	<ol style="list-style-type: none"> 1. Click the Remove Error button to remove this error. 2. If the error still exists, contact our customer service department.
LYC-1 not replaced.	<ol style="list-style-type: none"> 1. Click the Remove Error button to remove this error. 2. If the error still exists, contact our customer service department.
LYC-2 not replaced.	<ol style="list-style-type: none"> 1. Click the Remove Error button to remove this error. 2. If the error still exists, contact our customer service department.
Abnormal 12V driving power supply.	<ol style="list-style-type: none"> 1. Please turn off the analyzer power directly and restart later. 2. If the error still exists, contact our customer service department.
Abnormal 24V driving power supply.	<ol style="list-style-type: none"> 1. Please turn off the analyzer power directly and restart later. 2. If the error still exists, contact our customer service department.
DIL-C not enough.	<ol style="list-style-type: none"> 1. Enter Reagent Management to modify the reagent information as instructed in 11 Reagent Management. 2. Click the Remove Error button to remove this error. 3. If the error still exists, contact our customer service department.
LYC-1 not enough.	<ol style="list-style-type: none"> 1. Enter Reagent Management to modify the reagent information as instructed in 11 Reagent Management. 2. Click the Remove Error button to remove this error. 3. If the error still exists, contact our customer service department.
LYC-2 not enough.	<ol style="list-style-type: none"> 1. Enter Reagent Management to modify the reagent information as instructed in 11 Reagent Management. 2. Click the Remove Error button to remove this error. 3. If the error still exists, contact our customer service department.

Appendix A Specifications

A.1 Classification

According to the CE classification, the Auto Hematology Analyzer belongs to in vitro diagnostic medical devices, rather than those covered by Annex II and devices for performance evaluation.

A.2 Reagents

Reagent Type	Reagent Name
Diluent	DIL-C Diluent
Lyse	LYC-2 Lyse
	LYC-1 Lyse
Medical cleanser	Cleanser

A.3 Parameters

Parameter	Abbreviation	Default Unit
White Blood Cell count	WBC	10 ⁹ /L
Number of Neutrophils	Neu#	10 ⁹ /L
Number of lymphocytes	Lym#	10 ⁹ /L
Number of Monocytes	Mon#	10 ⁹ /L
Number of Eosinophils	Eos#	10 ⁹ /L
Number of Basophils	Bas#	10 ⁹ /L
Number of Abnormal Lymphocytes	ALY# (RUO)	10 ⁹ /L
Number of Large Immature Cells	LIC# (RUO)	10 ⁹ /L
Number of Nucleated Red Cells	NRBC# (RUO)	10 ⁹ /L
Percentage of Neutrophils	Neu%	%
Percentage of Lymphocytes	Lym%	%
Percentage of Monocytes	Mon%	%
Percentage of Eosinophils	Eos%	%

Parameter	Abbreviation	Default Unit
Percentage of Basophils	Bas%	%
Percentage of Abnormal Lymphocytes	ALY% (RUO)	%
Percentage of Large Immature Cells	LIC% (RUO)	%
Percentage of Nucleated Red Cells	NRBC% (RUO)	%
Red Blood Cell count	RBC	10 ¹² /L
Hemoglobin Concentration	HGB	g/L
Hematocrit	HCT	%
Mean Corpuscular Volume	MCV	fL
Mean Corpuscular Hemoglobin	MCH	pg
Mean Corpuscular Hemoglobin Concentration	MCHC	g/L
Red Blood Cell Distribution Width - Standard Deviation (RDW-SD)	RDW-SD	fL
Red Blood Cell Distribution Width - Coefficient of Variation (RDW-CV)	RDW-CV	%
Platelet count	PLT	10 ⁹ /L
Mean Platelet Volume	MPV	fL
Platelet Distribution Width	PDW	None
Plateletcrit	PCT	%
Platelet-large cell count	P-LCC	10 ⁹ /L
Platelet-large cell ratio	P-LCR	%
White Blood Cell Histogram	WBC Histogram	None
Red Blood Cell Histogram	RBC Histogram	None
Platelet Histogram	PLT Histogram	None
Basophils Scattergram	BASO Scattergram	None
DIFF Scattergram	DIFF Scattergram	None

NOTE

The NRBC#, NRBC%, P-LCR and P-LCC are parameters for DF52, DF55 and DF56 only.

A.4 Performance Specifications

A.4.1 Display Range

Parameter	Linearity Range	Display Range
WBC	$(0\sim 300) \times 10^9/L$	$(0\sim 999) \times 10^9/L$
RBC	$(0.00\sim 8.50) \times 10^{12}/L$	$(0\sim 18.00) \times 10^{12}/L$
HGB	$(0\sim 250) \text{ g/L}$	$(0\sim 300) \text{ g/L}$
PLT	$(0\sim 3000) \times 10^9/L$	$(0\sim 5000) \times 10^9/L$
HCT	0%~67%	0%~80%

A.4.2 Normal Background

Parameter	Normal Background
WBC	$\leq 0.2 \times 10^9/L$
RBC	$\leq 0.02 \times 10^{12}/L$
HGB	$\leq 1 \text{ g/L}$
PLT	$\leq 10 \times 10^9/L$
HCT	$\leq 0.5\%$

A.4.3 Linearity Range

Parameter	Linearity range	Deviation range (Whole blood mode)
WBC	$(0.00\sim 100.00) \times 10^9/L$	$\pm 0.30 \times 10^9/L$ or $\pm 5\%$
	$(100.01\sim 300.00) \times 10^9/L$	$\pm 10\%$
RBC	$(0.00\sim 8.50) \times 10^{12}/L$	$\pm 0.05 \times 10^{12}/L$ or $\pm 5\%$
HGB	$(0\sim 250) \text{ g/L}$	$\pm 2 \text{ g/L}$ or $\pm 2\%$
PLT	$(0\sim 1000) \times 10^9/L$ (RBC ≤ 7.0)	$\pm 10 \times 10^9/L$ or $\pm 8\%$
	$(1001\sim 3000) \times 10^9/L$ (RBC ≤ 7.0)	$\pm 12\%$
HCT	0%~67%	$\pm 2\%$ (HCT value) or $\pm 3\%$ (deviation percent)

A.4.4 Repeatability

These repeatability requirements apply only to the situation in which a qualified sample has been run for 10 times and the results are used to calculate the repeatabilities.

Parameter	Condition	Whole Blood Repeatability (CV%/absolute deviation d*)
WBC	$(4.0\sim 15.0) \times 10^9/L$	$\leq 2.0\%$
Neu%	50.0%~60.0%	± 4.0 (absolute deviation)
Lym%	25.0%~35.0%	± 3.0 (absolute deviation)
Mon%	5.0%~10.0%	± 2.0 (absolute deviation)
Eos%	2.0%~5.0%	± 1.5 (absolute deviation)
Bas%	0.5%~1.5%	± 0.8 (absolute deviation)
RBC	$(3.50\sim 6.00) \times 10^{12}/L$	$\leq 1.5\%$
HGB	(110~180) g/L	$\leq 1.5\%$
PLT	$(100\sim 149) \times 10^9/L$	$\leq 6.0\%$
	$(150\sim 500) \times 10^9/L$	$\leq 4.0\%$
MCV	(70~120) fL	$\leq 1.0\%$
MPV	-	$\leq 4.0\%$

*: Absolute deviation d = analysis result - average of analysis results

A.4.5 Carryover

Parameter	Carryover
WBC	$\leq 0.5\%$
RBC	$\leq 0.5\%$
HGB	$\leq 0.5\%$
PLT	$\leq 1.0\%$
HCT	$\leq 0.5\%$

A.5 Sample Interference

If there is sample interference, the analysis results of the sample may be affected. See the table below.

Parameter	Analysis Results	Interference Source
WBC	Low WBC count	Leukoagglutination

Parameter	Analysis Results	Interference Source
	High WBC count	<ul style="list-style-type: none"> • Possible Platelet agglutination • Cool insoluble protein • Cryoglobulins • Fibrin • Excessive numbers of giant platelets (platelets > 1000 × 10⁹/L) • Nucleated red blood cells
RBC	Low RBC count	<ul style="list-style-type: none"> • Agglutinated RBCs (Cold agglutinins) • Microcythemia • Schistocytes
	High RBC count	<ul style="list-style-type: none"> • Leukocytosis (>100 × 10⁹/L) • Excessive numbers of giant platelets (platelets > 1000 × 10⁹/L)
HGB	High HGB count	<ul style="list-style-type: none"> • Leukocytosis (>100 × 10⁹/L) • Chylaemia • Jaundice • Paraprotein
HCT	Low HCT value	<ul style="list-style-type: none"> • Agglutinated RBCs (Cold agglutinins) • Microcytes • Schistocytes
	High HCT value	<ul style="list-style-type: none"> • Leukocytosis (>100 × 10⁹/L) • Severe diabetes • Uremia • Spherocytes
PLT	Low PLT count	<ul style="list-style-type: none"> • Possible Platelet agglutination • pseudothrombocytopenia • Giant platelets
	High PLT count	<ul style="list-style-type: none"> • Microcytes • Schistocytes • WBC fragments • Cool insoluble protein • Cryoglobulins

A.6 Input/output Device



WARNING

- Accessory equipment connected to the analogue and digital interfaces must comply with the relevant Safety and EMC standards (e.g., IEC 60950 Safety of Information Technology Equipment Standard and CISPR 22 EMC of Information Technology Equipment Standard (CLASS B)). Anyone who connects additional equipment to the signal input or output ports and configures an IVD system is responsible for ensuring that the system works properly and complies with the safety and EMC requirements. If you have any problem, consult the technical services department of your local agent.
 - Be sure to use specified fuse only.
-
- Analyzer
 - Touch screen: 10.4 inches embedded touch screen with a resolution of 800×600
 - One LAN interface
 - 4 USB interfaces
 - Thermal printer (for DF52, DF55 and DF56 only)
 - Power
 - Voltage: A.C 100V~240V
 - Input power: ≤200VA
 - Frequency: 50/60 Hz
 - Fuse: T6.3AL 250V
 - Keyboard (Optional, USB)
 - Mouse (Optional, USB)
 - External barcode scanner (optional, USB)
 - External printer (optional, USB)
 - USB flash disk (optional, USB)

A.7 EMC Description

This equipment complies with the emission and immunity requirements of the IEC 61326-1:2012, EN 61326-1:2013, IEC 61326-6-2-6:2012 and EN 61326-2-6:2013. This equipment has been designed and tested to CISPR 11 Class B. In a domestic environment it may cause radio interference, in which case, you may need to take measures to mitigate the interference.

The test items, standards and requirements on electromagnetic compatibility for the environment are shown in the table below.

Test Item	Test Standard	Test Requirement
Conducted Disturbance	EN 61326-1:2013 EN 61326-2-6:2013	1Mode-Class B
Radiated Disturbance	EN 61326-1:2013 EN 61326-2-6:2013	1Mode-Class B

Test Item	Test Standard	Test Requirement
Harmonic Current	EN 61326-1:2013 EN 61326-2-6:2013	Class A
Voltage Fluctuation and Flicker	EN 61326-1:2013 EN 61326-2-6:2013	/
ESD Immunity	EN 61326-1:2013 EN 61326-2-6:2013	air discharge: $\pm 2, \pm 4, \pm 8$ kV contact discharge: $\pm 2, \pm 4$ kV
Radiated Electromagnetic Field Immunity	EN 61326-1:2013 EN 61326-2-6:2013	80MHz-1GHz, 1.4GHz-2GHz 3V/m 80%AM(1kHz); 2GHz-2.7GHz 1V/m 80%AM(1kHz)
EFT Immunity	EN 61326-1:2013 EN 61326-2-6:2013	1kV 5/50 ns Tr/Th 5kHz repetition frequency
Surge Immunity	EN 61326-1:2013 EN 61326-2-6:2013	1.2/50(8/20) μ s Tr/Th 1kV L-N 2kV L-PE, N-PE
Conducted Immunity	EN 61326-1:2013 EN 61326-2-6:2013	0.15MHZ~80MHZ 3V(r.m.s)(unmodulated)
Voltage Dips and Interruptions Immunity	EN 61326-1:2013 EN 61326-2-6:2013	Voltage dips: 0%UT, 1cycle 40%UT, 5cycle 70%UT, 25cycle Voltage interruption: <5%UT, 250cycle

A.8 Environment Conditions

NOTE

Be sure to use and store the analyzer in the specified environment.

Environment Conditions	Operating Environment	Storage Environment	Running Environment
Ambient temperature	15°C~30°C	-10°C~40°C	5°C~40°C
Relative humidity	20%~90%	10%~90%	10%~90%
Atmospheric pressure	70kPa~106kPa	50kPa~106kPa	70kPa~106kPa

A.9 Dimensions and Weight

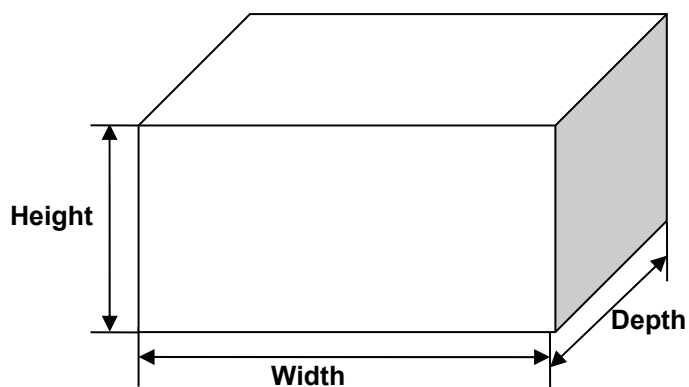

Analyzer	Dimensions and Weight
Width (mm)	364
Height (mm)	498
Depth (mm)	431
Weight (kg)	28

A.10 Expected Service Life

8 years.

A.11 Contraindications

None

Appendix B Terms and Abbreviations

CWB	Capillary Whole Blood
PD	Predilute
VWB	Venous Whole Blood

Appendix C Packing List

For details, see the packing list file shipped with the device.

CE



Shenzhen Dymind Biotechnology Co.,Ltd.

10th Floor, Building B, High-tech Park, Guangqiao Road, Tianliao Community, Yutang Street,
Guangming District, Shenzhen 518107, P. R. China

Fax: (86-755)26746162

Website: <http://www.dymind.com>

Tel: (86-755)26989825

Email: intl@dymind.com

