



ADDRA Smart Water Solution

Quick Start Guide



Contents

HISTORY OF CHANGES.....	3
TERMS AND ABBREVIATIONS	3
1 PURPOSE	4
2 UNPACKING AND INSPECTION	4
3 GENERAL INFORMATION	4
3.1 WATER METER GENERAL INFORMATION.....	4
3.2 WATER VALVE GENERAL INFORMATION.....	6
4 GENERAL VIEW AND OVERALL DIMENSIONS.....	7
4.1 WATER METER GENERAL VIEW AND OVERALL DIMENSIONS	7
4.2 WATER VALVE GENERAL VIEW AND OVERALL DIMENSIONS	8
5 DEVICES NAMEPLATES	9
5.1 WATER METER NAMEPLATE	9
5.2 WATER VALVE NAMEPLATE	10
6 RECOMMENDED SOFTWARE TOOLS.....	10
7 SAFETY PRECAUTIONS	10
8 <i>INSTALLATION PREREQUISITES</i>	11
9 INSTALLATION.....	11
10 COMMISSIONING.....	13
11 WATER METER STATES AND DISPLAY	13
12 CHECKING WM AND WV BY ADDRA CT APPLICATION	15
13 REFERENCES	15

History of changes

Version	Date	Author	Comment
<i>1.0</i>	<i>16.04.2021</i>	<i>Sergei Budigai</i>	
<i>1.1</i>	<i>15.03.2022</i>	<i>Valentin Acbiic Olga Keloglu</i>	

Terms and abbreviations

Abbreviation	Description
<i>BLE</i>	Bluetooth Low Energy
<i>DN</i>	Diameter Nominal
<i>HES</i>	Head-End System
<i>LCD</i>	Liquid Crystal Display
<i>PN</i>	Pressure Nominal
<i>WAN</i>	Wide Area Network
<i>WM</i>	Water Meter
<i>WV</i>	Water Valve

1 Purpose

The quick start guide (hereinafter referred to as guide) describes the installation and initial testing process of the ADDRA devices operability.

ADDRA devices being a part of ADDRA Smart Water Solution include Water Meter (WM) for water metering and ADDRA Water Valve (WV) to control water flow.

Read this guide carefully before devices installation or operation. Keep the guide accessible for future reference.

2 Unpacking and inspection

Upon receipt of devices, do the following:

1. Carefully inspect the packing box for any possible external damage. Note that the group shipment with use of a many-placed packing box is allowed.
2. Carefully open the packing box, remove all packing materials, and pull out devices from the box.
 - 2.1. Note: Please, keep the packing box and all packing materials in case if devices need to be returned to the manufacturer (according to the contract).
3. Make sure that the delivery set is complete. The delivery set includes the following:
 - 3.1. WM - 1 piece;
 - 3.2. WV - 1 piece;
 - 3.3. User's manual – 1 piece. The delivery of one user's manual for group packing is allowed;
 - 3.4. Mounting pieces set – 1 set. The mounting pieces set is delivered as agreed, and can include fittings, for example, reducing bushes and nipples;
 - 3.5. Calibration description for WM – 1 copy. It is sent on request of organizations, making adjustment and calibration;
4. Visually inspect devices for any physical damages such as cracks, broken parts or any other signs of damage that may have occurred during shipment. Please, report any transport damage immediately.
5. NEVER install damaged devices, that is, if there are any signs of shipping damage to any section of its enclosure (and assembling parts).
6. Do not remove any seal from the WM, and do not open devices. It will invalidate the guarantee of devices and maybe the metrological approval of the WM.

Note that water meter is delivered with associated water valve paired during production.

3 General information

3.1 Water meter general information

The WM is based on ultrasonic principle and intended for cold water consumption metering. The WM with has no moving parts, requires no maintenance, and can be remotely read. The WM specifications are presented in the following table 1.

Table 1.

Parameter	Value		
Model	<i>WMP15</i>	<i>WMP20</i>	<i>WMP25</i>
Nominal diameter	<i>DN15</i>	<i>DN20</i>	<i>DN25</i>
Permanent flow rate, Q3 (m ³ /h)	<i>1.6</i> <i>2.5</i>	<i>2.5</i> <i>4</i>	<i>4</i> <i>6.3</i>
Thread	<i>G3/4"</i>	<i>G1"</i>	<i>G1¼"</i>
Dynamic range Q3/Q1	<i>R250</i> <i>R400</i>		
Installation sensitivity class	<i>U0/D0</i>		
Sensitivity threshold (l/h)	<i>2</i>		
Temperature class	<i>T50 (0.1 – 50 °C)</i>		
Storage temperature	<i>From (-25 °C) to (+70 °C)</i>		
Metrological class	<i>Class 2</i>		
Maximum operation pressure	<i>1.6 MPa</i>		
Pressure loss	<i>Δp40</i>		
Ingress Protection code	<i>IP68</i>		
Environmental class	<i>E1, M1</i>		
Installation	<i>Horizontal or vertical</i>		
Battery	<i>Lithium battery, up to 16 years lifetime in case of meter reading once per day</i>		
Interfaces	<i>Bluetooth</i>		
WAN Communication	<i>WM-BUS / LoRa</i> <i>LoRaWAN Channel plans by country:</i> <i>EU863-870, US902-928, AU915-928, AS923,</i> <i>IN865-867, RU863-870</i>		
Metrological LED	<i>10 000 imp/m³</i>		
Display	<i>LCD 8 digits</i>		

In order to avoid formation of air bubbles or vapour in the WM (cavitation) – and to ensure correct measurement under all normal circumstances – the operating pressure in the pipe

installation must observe the test conditions of OIML R49, which means that the static pressure downstream, immediately after the WM (the downstream) must always be minimum 0.03 MPa (0.3 bar).

3.2 Water valve general information

The WV is used to manage the water supply remotely from HES via the associated WM. The WM can be supplied with the WV on request.

The WV specifications are presented in the table 2.

Table 2.

Parameter	Value (VW15)
Type	Two-way, modulating
Pipe diameter	DN15, DN20, DN25
Port	Reduced port
Voltage supply	Lithium battery
Power consumption	0.1 W
Torque	$\leq 1.5 \text{ N}\cdot\text{m}$
Cycle time	20 seconds per 90° rotation
Frequency	50 Hz
Temperature class	T50
Ambient temperature	From 5 °C to 55 °C
Storage and transportation temperature	From -20 °C to +60 °C
Service life	>1000 times
Mean lifetime, not less than	16 years
IP rating	IP68
Pressure rating	PN16
Dimensions, L×W×H	64×80×78, mm
Interfaces with the WM	BLE 5.0
Indicators	One multi-purpose bicolor LED
Actuator protection	Limiting switches
Manual override	Not available

4 General view and overall dimensions

4.1 Water meter general view and overall dimensions

The overall view of the WMP:

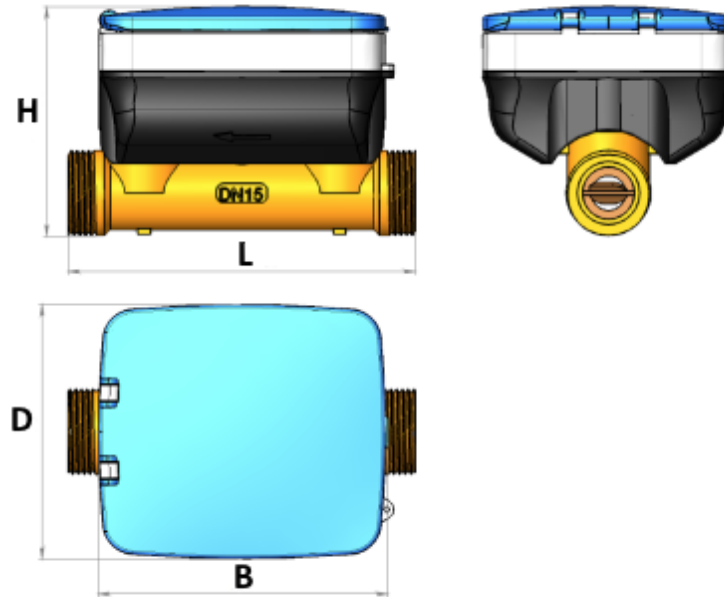

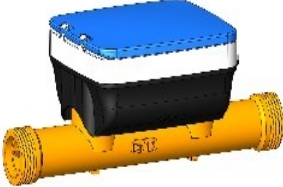



Fig.1. Overall dimensions of water meter WVPxx

Table 3.

Pipe diameter	Character	Short brass pipe, mm	Long brass pipe, mm
			
			
D15	L	110	165
	H	71	71
	D	80	80
	B	91	91
D20	L	130	195
	H	77	77

	D	80	80
	B	91	91
D25	L	190	225
	H	85	85
	D	80	80
	B	109	109

4.2 Water valve general view and overall dimensions

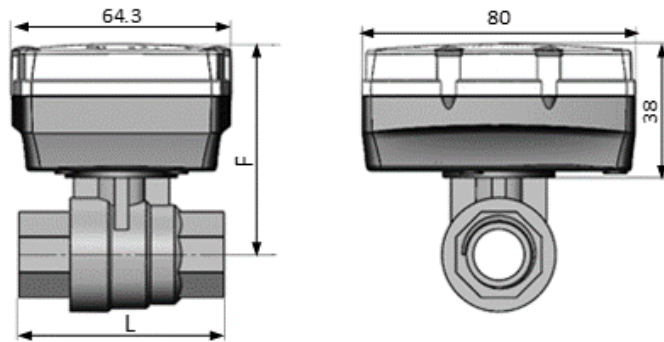

Dimensions	D15	D20	D25
L, mm	60	65.5	75
F, mm	61.5	69	72.5

Fig.2. General view and overall dimensions of flow control valve WVxx

5 Devices nameplates

5.1 Water meter nameplate

The WM basic parameters are placed on the face surface as illustrated below:

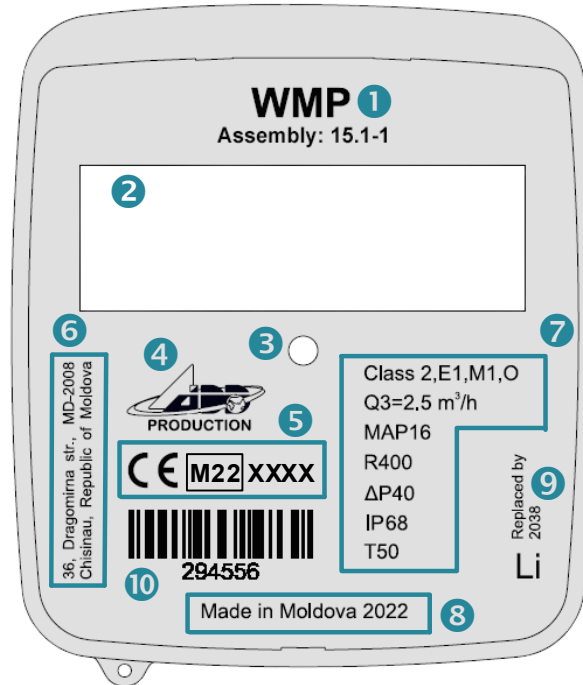

Table 4.

1	Meter model: Water Meter Potable
2	Display to view consumption data and states
3	Metrological LED
4	Meter manufacturer
5	CE mark accompanied with the last two digits of the year of manufacture (YY after M sign) and identification number of the notified body XXXX
6	Manufacturer's postal address
7	Technical parameters
8	Place of manufacturing and date
9	Battery expiry date
10	Barcode with serial number

5.2 Water valve nameplate



Table 5

1	Valve model: WV25.1-1 as an example
2	ADDRA technology logo
3	Meter manufacturer
4	Technical parameters
5	Li battery mark
6	CE mark
7	BLE logo
8	Place of manufacturing and date
9	Bicolor LED (red and green) to indicate the valve status at start and upon receipt of the special command.

6 Recommended software tools

Devices functionality correctness can be verified:

- **Locally** - using ADDRA Control Tool for consumers and COSEM Client application for service purposes. For more information, see [Reference 1](#);
- **Remotely** - from LoRa WAN Server, using Web-interface.

7 Safety precautions

The following precautions should be taken for a successful installation of the devices:

1. Devices must be installed and commissioned in accordance with the local regulations and standards that are in force.
2. Devices installation and removing should be carried out only by technically qualified, appropriately trained and authorized personnel, and only after entire reading of this guide.
3. The successful operation of devices depends on proper installation.
4. Note that neglect of installation requirements may lead to injury as well as damage of meter or other property.
5. Most activities in the process are executed by personnel on-site.
6. When installation is finished, the WM can be sealed up by the representatives of the authorized organization.

8 *Installation prerequisites*

Consider the following prerequisites, before starting the installation process:

1. Check the local regulations for installation. Examples of some local regulations:
 - 1.1. Mandatory installation of the additional equipment, for example, strainer (filter), non-return valve, drain off valve, and turnoff valves before and after devices.
 - 1.2. Minimum spacing requirements, for example, between devices and other objects and surfaces.
 - 1.3. Contact ADD GRUP company in case local regulations conflict with any of the following instructions.
2. Locate the place for the devices installation.
 - 2.1. Both devices can be installed in heated and in non-heated indoors as well.
 - 2.2. The location conditions should be within the ingress protection (IP) class and operating temperature range of the devices.
 - 2.3. Both devices are intended to be installed in a mechanical environment M1, with shock and vibrations of low significance.
 - 2.4. All parts of the devices must be easily accessible. Leave enough space for installation.
 - 2.5. Nameplates of both devices and display of the WM should be easily read.
3. Prepare the necessary tools and materials according to the type of the water supply pipe (copper, iron or plastic).
4. Prepare the pipe thread sealant: plumbers hemp/flax, thread seal tape or anaerobic sealant compound.
5. Find the water supply pipe and locate the water main turnoff valve.
6. If pressure in the piping system is too high pressure, then install a pressure regulator. If it is already installed, then make sure that it works and is adjusted correctly.
7. Check the devices compatibility and functionality.
 - 7.1. This may be the diameter of the holes of the pipes and the diameter of the holes of devices. The adapters for different diameters of the pipe may be needed.
 - 7.2. Use the ADDRA Control Tool to check the devices functionality. Get information for the WM and connect/disconnect the WV.
8. Note that prior to installation of devices, repair the piping system if pipes are corroded or damaged, and flush the upstream and downstream piping.
9. Make sure that the length of devices threads will not prevent sufficient tightening of the sealing surface, and make sure that the relevant couplers are used.
10. The Ethylene Propylene Diene Monomer (EPDM) gaskets for the cold water installations are recommended. The coupling's sealing surface and the gaskets must be clean and even. Always use new gaskets.

9 *Installation*

Before installing devices, make sure that the planning steps are completed and prerequisites are met.

1. Turn the main valve on the water supply pipe clockwise to shut off the water. Make sure that the water is shut off.

2. To depressurize the system, open a tap (faucet) and wait until water flow stops.
3. Choose the correct position for the WM installation. The WM can be installed both vertically and horizontally.
4. Ensure that the installed devices will be easily accessible for reading, inspection, and service.
5. If installing new devices skip to step 8.
6. When replacing existing devices, loosen couplings and remove devices and the old gaskets in the coupling nuts.
7. Clean the coupling nuts, removing any pipe thread sealant or dirt from the threads.
8. Verify the existing setting for proper alignment and spacing. Correct any misalignment and spacing in the setting.
9. Place the connection gaskets inside the connection coupling nuts. Note that depending on the couplings types, additional pipe thread sealants can be used.
10. Set the WM between the coupling nuts, properly positioned so that the flow indication/arrow on the WM housing points in the direction of flow.
11. Start the coupling nuts at the threaded WM ends. Verify that the coupling nuts are properly aligned to avoid cross threading damage (stripping) to the WM ends.
12. Tighten the couplings using an adjustable wrench, but do not overtighten.
13. Repeat the same actions for the WV. The WV should be installed on the WM outlet (along with the water flow) at a distance not more than 15 meters.
14. Make visual inspection of both devices installation.



Special fittings can be used to provide proper alignment to the pipe diameter. In the following figure the reducing brush is used between the WM and WV, and male nipple is used to connect the WV to the pipe system.

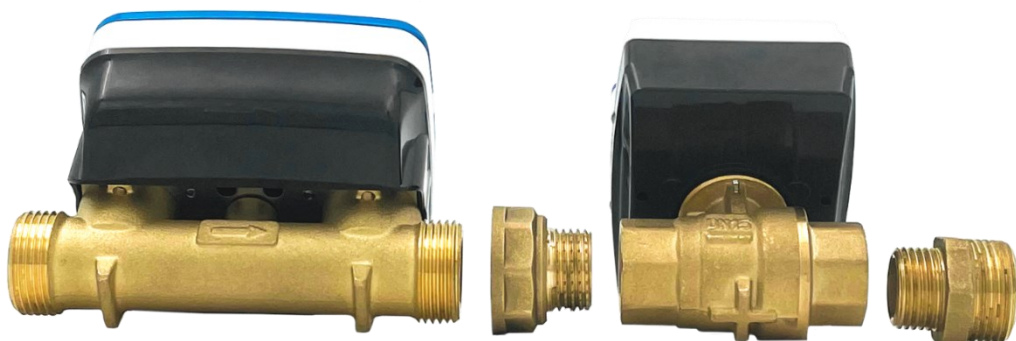

10 Commissioning

After successful installation, check again the correctness of devices installation, and then test them in the following way:

1. Check the WM display. Taking into consideration the fact that the water system has been depressurized, make sure that the DRY alarm is displayed.
2. Perform the tightness testing by opening the water main turnoff valve slowly, and filling the water supply pipe.
3. Visually check pipes for leaks. Note that for successful check, the pressure in the water supply pipe should be at least 0.03 MPa;
4. Check the WM display. The DRY alarm should disappear.
5. Open the water tap (faucet).
6. Wait for a while, and then check the WM display. Make sure that the flow rate (m³/h), volume (liters), and temperature values are recorded and displayed correctly.
7. Check the WV. The external sign (see table 5) on the paired WM should be presented.

In case of any leakages and errors presence, devices should be removed and installed again in the proper way.

11 Water meter states and display

The WM can be in one of the following states:

- Off - the WM is not powered.
- Active – the WM is powered. It measures and displays the current parameter on the LCD, and can exchange data via BLE and WAN modems.

The meter features easily readable LCD to visualize, for example, measurement data, states, and info codes:

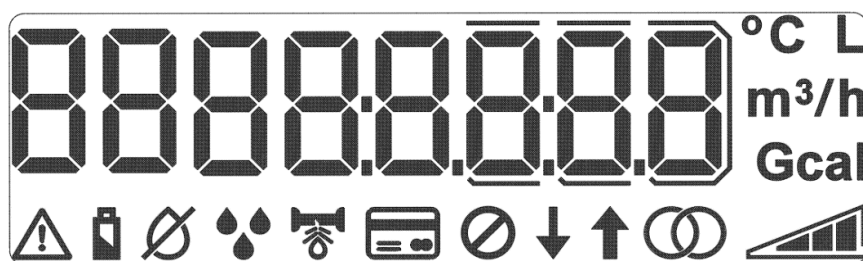

Each measurement value  is accompanied by its measurement unit.

The number of decimals is configurable. The volume resolution is 0.000001 m³. Almost all the data (both screens and state symbols) are defined by legally relevant firmware. Display icons are described in Table 8. The symbols managed by legally non-relevant firmware are marked with an asterisk.

The info codes switch off automatically when the conditions that activated them have been removed.

The number of m³ is displayed by the left five digits.

A number of info codes at the bottom of the display indicate extraordinary water consumption conditions.

An active info code in the form of one of the following words flashes: TAMPER, LOWBAT, DRY, LEAK, BURST, and REVERSE.

Table 6

















Icon	Description
	<p>TAMPER alarm: attempted fraud or tampering, for example, the WM cover opening, magnetic field detection. The WM is no longer valid for billing purposes.</p> <p>The alarm remains ON if there has been a tampering attempt.</p>
	<p>LOWBAT alarm: low battery.</p>
	<p>DRY alarm: the WM is not filled with water.</p> <p>The alarm disappears when the WM is filled with water.</p>
	<p>LEAK alarm: possible water leakage. During the latest 24 hours the water in the WM has not been stagnant for minimum one continuous hour. This could indicate an untighten faucet or a running toilet cistern.</p> <p>The alarm disappears when the water has been stagnant for an hour.</p>
	<p>BURST alarm: possible breakthrough pipe. The water flow has exceeded a preprogrammed limit for minimum 30 minutes which indicates a pipe burst.</p> <p>The alarm disappears when the consumption falls to normal level.</p>
 *	<p>CREDIT alarm: It is displayed when the threshold is reached in prepay-mode (credit is too small, the account should be replenished).</p>
 *	<p>CLOSED alarm: It is displayed when the water supply WV is closed, for example, credit is over in prepay-mode.</p>
	<p>REVERSE alarm: the water flows in the reverse direction through the WM.</p> <p>The alarm disappears when the water flows in the right direction.</p>
	<p>ABOVE: the flow rate of water above the sensitivity threshold of the WM is detected. The icon blinks in proportion to the flow rate (at least four distinct blink frequencies).</p>
 *	<p>EXTERNAL: Appears when connected to an external valve via BLE.</p>
 *	<p>COMMUNICATION INDICATOR: Displays the status and level of the WAN channel signal (see details in the following table)</p>

Table 7

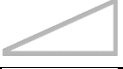
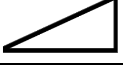
Communication indicator		LoRaWAN 2G/3G/LTE
WAN symbol not displayed		WAN channel disabled (not configured)
Blinking empty frame		WAN modem hardware error
Empty frame		Not registered in the network
Frame and 1 segment		Registered in the network, signal level is low
Frame and 2 segments		Registered in the network, signal level is good
Frame and 3 segments		Registered in the network, signal level is high
Frame and 3 blinking segments		Data exchange with Control system in progress
Blinking frame and 3 segments		WAN modem configuration error

12 Checking WM and WV by ADDRA CT application

Start the ADDRA CT application. Make sure that the meter and mobile device are in range of each other with BLE turned on. Check the WM general information.

- 1) **Firmware Revision** – the WM firmware version, for example, v.1.2.0.9.
- 2) **Serial Number** – the WM serial number, for example, 295367.
- 3) **Volume Consumed** – the consumed volume of WM, in cubic meters with three decimal places, for example, 40.530 m³.
- 4) **Request Date** – the date when the displayed information has been requested and received, for example, 2022.03.14 11:03.

Check valve state:

- a) **ValveState** – the WV state should be connected.
- b) **ValveConnectionError** – connection with WV errors should be **No**.

13 References

1. ADDRA Control Tool App. User Manual