

THE NETHERLANDS
(N E D E R L A N D)**COMMUNICATION**Concerning ⁽¹⁾:

- ~~approval granted~~
- approval extended
- ~~approval refused~~
- ~~approval withdrawn~~
- ~~production definitely discontinued~~

of a type of tyre for motor vehicles pursuant to Regulation number 30.

Approval number: E4-30R-02104182**Extension number: 02**

1. Manufacturer's name and address : Shandong Longyue Rubber Co., Ltd.
The South of Yalujiang Road, Wenzhuang
Village Qinghe Agency of Cao County, Heze
City, Shandong Province 274400 China (PROC)
2. Tyre type designation ⁽²⁾
 - 2.1. Brand-name(s)/trademark(s) : GRENLANDER; ARIVO; CONSTANCY;
ILINK; LUXXAN; RHINO; CRYSTAL; T
TYRE; ROCKBLADE; FRONWAY; SAILWIN;
XBRI;ROADMARCH;

- 2.2. Trade description(s)/Commercial name(s) : MAHO 77; TOPOWER 87 H/T; TERRANO ARV H/T; POWERCITY 77; ROADPOWER H/T; FORZA A/T2; ROADKING H/T; FORZA H/T2; INSPIRER F4; ROCK 717 H/T; MAGA A/T ONE; FORZA A/T; TERRA MAX LSR1 A/T; TERRA XPLOER C1 A/T; TERRAMAX ARV A/T; ROCKBLADE A/T I; GLADIATAX A/T I; INSPIRER A/T I; LY788; TOUGH TRAC A/T I; ROCK 727 A/T; LY969; MAGA A/T TWO; TERRA MAX LSR2 A/T; TERRA XPLOER C2 A/T; GLADIATAX A/T II; TERRAMAX ARV PRO A/T; INSPIRER A/T II; ROCKBLADE A/T II; TOUGH TRAC A/T II; ROCK 737 A/T; L-FINDER78; HIGHROAD H/T 78; SPEEDROAD H/T 78; FORZA H/T; INSPIRER F2; GP1000; Rapid; ROCK 788; L-SNOW99; ROCK 919S; ICEPOWER 99; ICEWINNER 99; INSPIRER W8; WINTERCROSS ARW7; COLO H01; PREMIO ARZ1; THREE; L-GRIP66; LY168; ECOGREEN 66; VENUSATR 66; ECOLOGY; INSPIRER C4; ROCK 515; Energize; PRIMESTAR 66; GREENWING A/S; MULTIMATCH A/S; PRIME A/S; FRONWING A/S; FREIMATCH A/S; FORTY ONE; Carlorful A/S; INSPIRER A/S 1; ROCK A/S ONE; Winter GL868; WINMASTER ARW2; LY868; Winter IL868; SNOWROVER 868; ICEWINNER 868; ROCK 868S; ICEPOWER 868; THIRTY TWO; INSPIRER W20; TWENTY TWO; Maxim; PRIMEMARCH H/T 77; PRIMEMAX A/T II; PRIMEMAX A/T I;
3. If applicable, name and address of the manufacturer's representative : ---
4. Summarised description :
- 4.1. Tyre size designation : 225/70R16
- 4.2. Category of use : ~~normal~~/snow/~~special use~~/temporary use⁽¹⁾
- 4.3. Structure : ~~diagonal/bias belted~~/radial/~~run flat~~ tyre⁽¹⁾
- 4.4. Speed category symbol : H
- 4.5. Load-capacity index : 103



5. Technical service and, where applicable, test laboratory approved for purposes of approval or of verification of conformity : CSI S.p.A.
v.le Lombardia 20
20021 Bollate (MI)
Italy
6. Date of report issued by that service : 15/10/2018
26/06/2019
7. Number of report issued by that service : 86-R30-3505/18-00
0124\ISP\OMLS\19_101
8. Reason(s) of extension (if applicable) : Addition of Brand-names
Deletion of Brand-names
Addition of Trade descriptions
Deletion of Trade descriptions
9. Any remarks : Change of Technical Service
10. Place : Zoetermeer
11. Date : 16 July 2019
12. Signature :



T. Ploshchansky

13. The list of documents in the approval file which are deposited at the administrative service having delivered the approval and which can be obtained upon request.
- Application form relating to ECE approval for a pneumatic tyre pursuant to Regulation number 30.
 - The drawing of the tyre's sidewalls, tread and dimensioned cross-section.
 - The test report as mentioned in item 7.

⁽¹⁾ Strike out what does not apply.

⁽²⁾ A list of Brand name(s)/trademark(s) or Trade description(s)/ Commercial name(s) may be annexed to this communication

RAPPORTO DI PROVA / TEST REPORT

NUMBER

0124\ISP\OMLS\19_101

ISSUE DATE

26/06/2019

DIVISION

AUTOMOTIVE

LABORATORY

Homologation

SPECIMEN DESCRIPTION

Tyre Size

225/70R16**APPROVAL EXTENSION TESTS****MANUFACTURER****Shandong Longyue Rubber Co., Ltd.**

The South of Yalujiang Road, Wenzhuang Village Qinghe Agency of Cao County
Heze City, Shandong Province 274400 China(PROC)

REFERENCE STANDARD**Regulation 30/02**

Supplement 20

(E/ECE/324/ Rev.1/Add.29/Rev.3/Amend.6 – E/ECE/TRANS/505/ Rev.1/Add.29/Rev.3/Amend.6)

GENERAL DATA

Test date:	N/A
Test site:	N/A
Sampling:	N/A
Deviation from test methods:	N/A

DECLARATIONS

Test results contained in this test report pertain exclusively to the tested specimen.

This test report cannot be reproduced partially without the consent of the test center managing director.



PRODUCT IDENTIFICATION

<p>Manufacturer's name and address</p>	<p>Shandong Longyue Rubber Co., Ltd. The South of Yalujiang Road, Wenzhuang Village Qinghe Agency of Cao County, Heze City, Shandong Province 274400 China (PROC)</p>
<p>Brand-name(s) / trademark(s)</p>	<p>GRENLANDER; ARIVO; CONSTANCY; ILINK; LUXXAN; RHINO; CRYSTAL; T TYRE; ROCKBLADE; FRONWAY; SAILWIN; XBRI;<u>ROADMARCH;</u></p>
<p>Trade description(s) / Commercial name(s)</p>	<p>MAHO 77; TOPOWER 87 H/T; TERRANO ARV H/T; POWERCITY 77; ROADPOWER H/T; FORZA A/T2; ROADKING H/T; FORZA H/T2; INSPIRER F4; ROCK 717 H/T;MAGA A/T ONE; FORZA A/T; TERRA MAX LSR1 A/T; TERRA XPLOER C1 A/T; TERRAMAX ARV A/T; ROCKBLADE A/T I; GLADIATAX A/T I; INSPIRER A/T I; LY788; TOUGH TRAC A/T I; ROCK 727 A/T;LY969;MAGA A/T TWO; TERRA MAX LSR2 A/T; TERRA XPLOER C2 A/T; GLADIATAX A/T II; TERRAMAX ARV PRO A/T; INSPIRER A/T II; ROCKBLADE A/T II;TOUGH TRAC A/T II; ROCK 737 A/T;L-FINDER78; HIGHROAD H/T 78; SPEEDROAD H/T 78; FORZA H/T; INSPIRER F2; GP1000; Rapid; ROCK 788; L-SNOW99;ROCK 919S; ICEPOWER 99; ICEWINNER 99; INSPIRER W8; WINTERCROSS ARW7; <u>COLO H01; PREMIO ARZ1; THREE; L-GRIP66;</u> <u>LY168;ECOGREEN 66; VENUSATR 66; ECOLOGY;</u> <u>INSPIRER C4;ROCK 515; Energize; PRIMESTAR 66;</u> <u>GREENWING A/S; MULTIMATCH A/S;PRIME A/S;</u> <u>FRONWING A/S;FREIMATCH A/S;FORTY ONE;</u> <u>Carlorful A/S;INSPIRER A/S 1;ROCK A/S ONE;</u> <u>Winter GL868;WINMASTER ARW2;LY868;</u> <u>Winter IL868;SNOWROVER 868;ICEWINNER 868;</u> <u>ROCK 868S;ICEPOWER 868;THIRTY TWO;</u> <u>INSPIRER W20;TWENTY TWO; Maxim; PRIMEMARCH H/T</u> <u>77; PRIMEMAX A/T II;PRIMEMAX A/T I;</u></p>



Tyre size designation	225/70R16
Category of use	Snow
Tyre structure	Radial
Speed category symbol	H
Load capacity index	103

TYRE MAIN FEATURES

See attached Technical Sheet.



APPROVAL STATUS

Approval Number: E4-30R-02104182 Ext.01 Last amended on: 05/11/2018

For details, see test reports:

- 86-R30-3505/18-00 issued on 15/10/2018 by TUV Rheinland Kraffahrt GmbH

REASON FOR EXTENSION

- Addition of Brand-names
- Deletion of Brand-names
- Addition of Trade descriptions
- Deletion of Trade descriptions



SUMMARY OF TEST RESULTS

The results of the previous tests are still valid as no difference can affect tests already performed and all new variant/versions fulfil the requirements of Regulation ECE 30/02.

Tests and verification		PASS	FAIL	N/A	R
1	Test tyre details	<input checked="" type="checkbox"/>	<input type="checkbox"/>	<input type="checkbox"/>	
2	Test results	<input checked="" type="checkbox"/>	<input type="checkbox"/>	<input type="checkbox"/>	



RESULTS

Following verification and tests performed, we declare that the products submitted for approval comply with all technical requirements of UNECE Regulation 30/02.

DATA
Date

26/06/2019

Settore Omologazioni
Test Engineer

Luca Bolgiani

**Area Omologazioni**
Homologation Area

Ing. Daniele Gervasini



Il documento è firmato digitalmente ai sensi del D.Lgs. 82/2005 s.m.i. e norme collegate e sostituisce il documento cartaceo e la firma autografa / The document is digitally signed in accordance with Legislative Decree n. 82/2005 as amended and replaces the paper document and the handwritten signature.



APPLICATION FOR APPROVAL OF A TYPE OF PNEUMATIC TYRE ACCORDING TO ECE
REGULATION No. 30, 02 SERIES OF AMENDMENTS

1. The Brand name(s) or trademark(s) ⁽²⁾ : GRENLANDER; ARIVO; CONSTANCY; ILINK;
LUXXAN; RHINO; CRYSTAL; T TYRE;
ROCKBLADE; FRONWAY; SAILWIN;
XBRI;ROADMARCH;
2. Trade description(s) or Commercial name(s) ⁽²⁾ : MAHO 77; TOPOWER 87 H/T; TERRANO ARV H/T;
POWERCITY 77; ROADPOWER H/T; FORZA A/T2;
ROADKING H/T; FORZA H/T2; INSPIRER F4;
ROCK 717 H/T;MAGA A/T ONE; FORZA A/T;
TERRA MAX LSR1 A/T; TERRA XPLOER C1 A/T;
TERRAMAX ARV A/T; ROCKBLADE A/T I;
GLADIATAX A/T I; INSPIRER A/T I; LY788;
TOUGH TRAC A/T I; ROCK 727 A/T;LY969;
MAGA A/T TWO; TERRA MAX LSR2 A/T;
TERRA XPLOER C2 A/T; GLADIATAX A/T II;
TERRAMAX ARV PRO A/T; INSPIRER A/T II;
ROCKBLADE A/T II;TOUGH TRAC A/T II;
ROCK 737 A/T;L-FINDER78; HIGHROAD H/T 78;
SPEEDROAD H/T 78; FORZA H/T; INSPIRER F2;
GP1000; Rapid; ROCK 788; L-SNOW99;ROCK 919S;
ICEPOWER 99; ICEWINNER 99; INSPIRER W8;
WINTERCROSS ARW7;
COLO H01; PREMIO ARZ1; THREE; L-GRIP66;
LY168;ECOGREEN 66; VENUSATR 66; ECOLOGY;
INSPIRER C4;ROCK 515; Energize; PRIMESTAR 66;
GREENWING A/S; MULTIMATCH A/S;PRIME A/S;
FRONWING A/S;FREIMATCH A/S;FORTY ONE;
Carlorful A/S;INSPIRER A/S 1;ROCK A/S ONE;
Winter GL868;WINMASTER ARW2;LY868;
Winter IL868;SNOWROVER 868;ICEWINNER 868;
ROCK 868S;ICEPOWER 868;THIRTY TWO;
INSPIRER W20;TWENTY TWO; Maxim;
PRIMEMARCH H/T 77; PRIMEMAX A/T II;
PRIMEMAX A/T I;
3. Manufacturer's name and address : Shandong Longyue Rubber Co., Ltd.
The South of Yalujiang Road, Wenzhuang Village Qinghe
Agency of Cao County, Heze City, Shandong Province
274400 China (PROC)
4. If applicable, name and address of the manufacturer's representative : N.A.
5. Summarized description
- 5.1. Tyre size designation : 225/70R16
- 5.2. Category of use : ~~normal~~/snow/~~special use~~/~~temporary use~~ ⁽¹⁾
- 5.3. Structure : ~~diagonal~~/~~bias belted~~/radial/~~run flat~~ tyre ⁽¹⁾
- 5.4. Speed category symbol : H
- 5.5. Load-capacity index : 103

(1) Strike out what does not apply.

(2) Modified points are underlined for extension.



- | | | |
|-----|---------------------------------------|---|
| 6. | Overall dimensions | : Calculated/ Annex 5 ⁽¹⁾ |
| | overall section width | : 227 |
| | outer diameter | : 719 |
| 7. | Factor 'x' | : 0.7 |
| 8. | Rims on which the tyre can be mounted | : 6½J |
| 9. | Measuring rim and test rim | : See attached test report |
| 10. | State whether the tyre is | : Tubeless / tube type ⁽¹⁾ |
| 11. | State whether the tyre is | : Standard / reinforced ⁽¹⁾ |
| 12. | State if special use tyre | : n.a. |
| | Professional Off-Road | : Yes / no ⁽¹⁾ |
| | Tread depth | : n.a. |
| | Void to fill ratio | : n.a. |
| 13. | Submitted for approval on (date) | : April 11 , 2019 |

We herewith declare that we have not applied and will not apply for approval with another Contracting Party of the ECE for the same type of product.

MANUFACTURER'S STAMP

Signature :

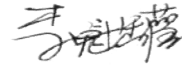

Name: Li Kuiguan

THIS APPLICATION IS ACCOMPANIED BY:

- A drawing of the tyre's side wall, tread and dimensioned cross section.
- The test report.

(1) Strike out what does not apply.

(2) Modified points are underlined for extension.



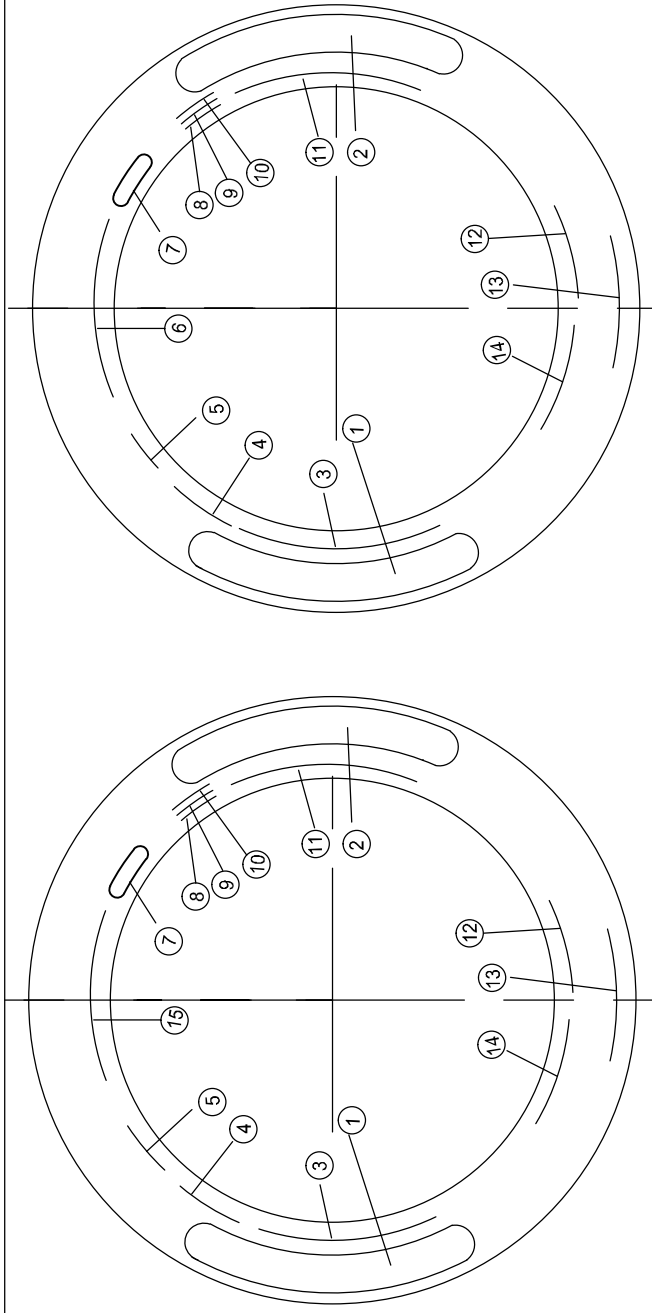
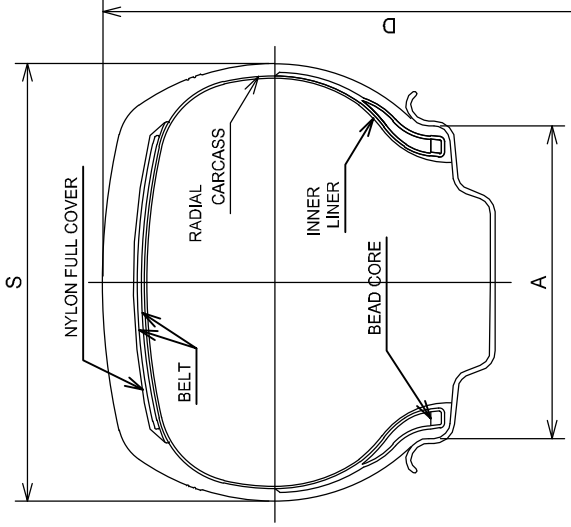

TREAD PATTERNS

REFER TO ATTACHMENT NO.11

1	GRENLANDER; ARIVD; CONSTANCY; ILINK; LUXXAN; RHINO; CRYSTAL; T TYRE; ROCKBLADE; FRONWAY; SAILWIN; XBRI;ROADMARCH;	9	MOLD No.
2	MAHO 77; TDPOWER 87 H/T; TERRANO ARV H/T; POWERCITY 77; ROADPOWER H/T; ROADKING H/T; FORZA H/T2 ; INSPIRER F4; ROCK 717 H/T; TWENTY TWO; Maxims; PRIMEMARCH H/T Z7.	10	RIM: 6½J
3	225/70R16 103H	11	SAFETY WARNING
4	RADIAL TUBELESS	12	PLIES:TREAD 2POLYESTER 25STEEL 1NYLON SIDEWALL 2POLYESTER
5	M+S	13	TREADWEAR 460 TRACTION A TEMPERATURE A
6	DOT 17B KMEKPA XXXX (DATE CODE)	14	MAX. LOAD 875kg (1929 LBS) AT 300 kPa (44 PSI) COLD
7	ECE APPROVAL MARK	15	DOT 17B KMEKPA
8	MADE IN CHINA	16	



TIRE SIZE	D(mm)	S(mm)	A(mm)	LOAD INDEX	SPEED CODE	REMARK
225/70R16	722	228	165	103H		

SCALE : FREE	DATE : 2019.4.11	DESIGNED BY	CHECKED BY	APPROVED BY	DRAWING NO.
SHANDONG LONGYUE RUBBER CO., LTD.		Cheng Yongchao	Xie Baoshan	Shen Maoqiao	
			TITLE		225/70R16 103H

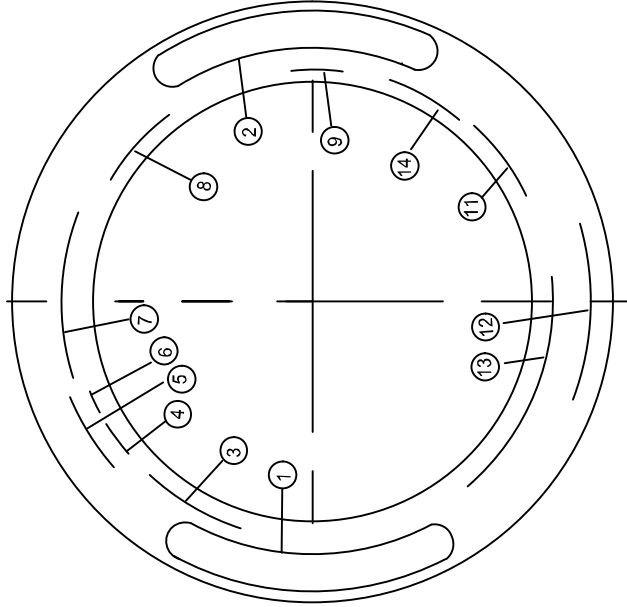
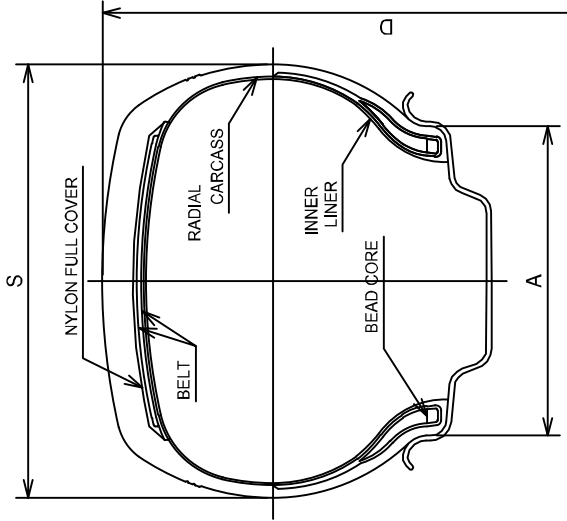

UPPER

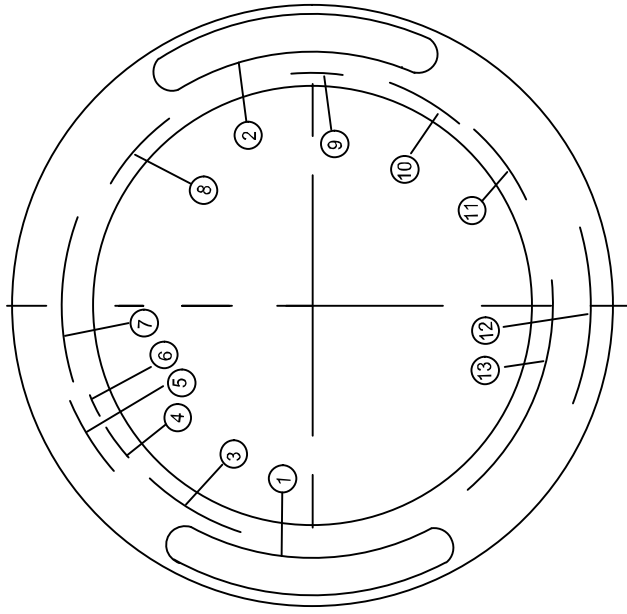

LOWER

TREAD PATTERNS
REFER TO ATTACHMENT NO.11

1	GRENLANDER; ARTIVO; CONSTANCY; ILINK; LUXXAN; RHINO; CRYSTAL; T TYRE; ROCKBLADE; FRONWAY; SAILWIN; XBRIDROADMARCHI	8	MAX. LOAD 875kg (1929 LBS) MAX. PRESS. 300KPa (44PSI)
2	MAGA A/T ONE; TERRA MAX LSRT A/T; TERRA XPLORER C1 A/T; TERRAMAX ARV A/T; ROCKBLADE A/T; GLADIATAX A/T; FORZA A/T; INSPIRER A/T; TOUGH TRAC A/T; ROCK 727 A/T; PRIMEMAX A/T	9	MADE IN CHINA
3	PLIES: TREAD 2POLYESTER+2STEEL+NYLON SIDEWALL 2POLYESTER	10	DOT 17B XXXXXX XXXX (DATE CODE)
4	RIM: 6% α	11	ECE APPROVAL MARK
5	RADIAL TUBELESS	12	TREADWEAR XXX TRACTION X TEMPERATURE X
6	MOLD No.	13	SAFETY WARNING
7	225/70R16 103H M+S	14	DOT 17B XXXXXX

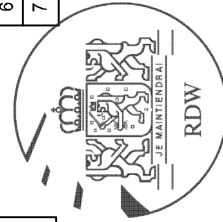

TIRE SIZE	D(mm)	S(mm)	A(mm)	LOAD INDEX	SPEED CODE	REMARK
225/70R16	722	228	165	103H	103H	

SCALE: FREE	DATE: 2019.4.11	DESIGNED BY Cheng Yongchao	CHECKED BY Xie Baoshan	APPROVED BY Shen Maoqiao	DRAWING NO. TITLE 225/70R16 103H
SHANDONG LONGYUE RUBBER CO., LTD.					

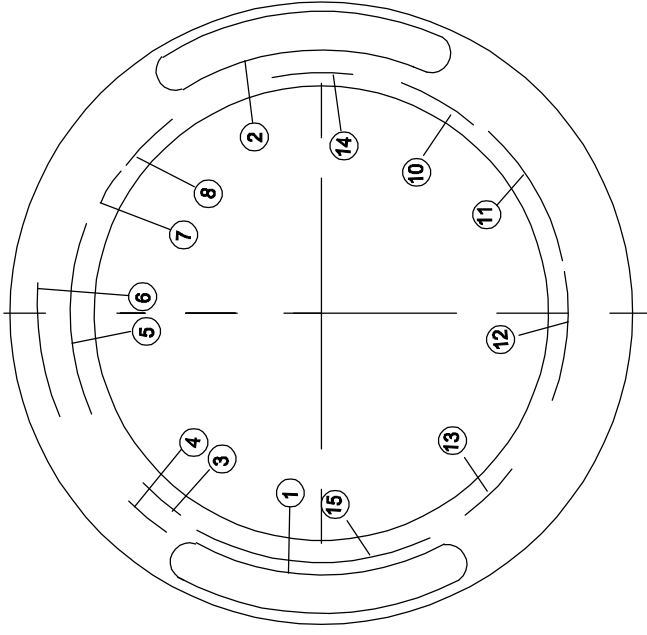
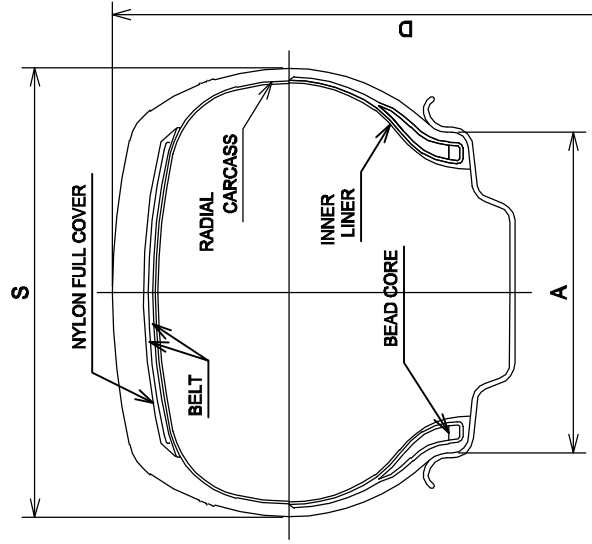

UPPER

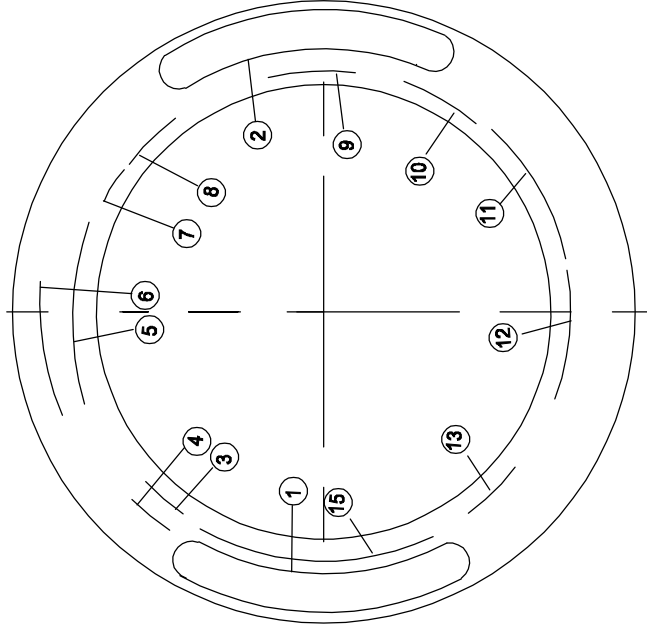

LOWER

TREAD PATTERNS
REFER TO ATTACHMENT NO.11

1	GRENLANDER; ARIVD; CONSTANCY; ILINK; LUXXAN; RHIND; CRYSTAL; T TYRE; ROCKBLADE; FRONWAY; SAIL WIN; XBRI; ROADMARCH I	9	DOT 17B KMEEPA XXXX (DATE CODE)
2	MAGA A/T TWO; TERRA MAX LSR2 A/T; TERRA XPLORER C2 A/T; TERRAMAX ARV PRO A/T; ROCKBLADE A/T II; GLADIATOR A/T II; FORZA A/T2; INSPIRER A/T II; TOUGH TRAC A/T II; ROCK 737 A/T; PRIMEMAX A/T II	10	RADIAL
3	RIM:614J	11	PLIES:TREAD 2POLYESTER+2STEEL+1NYLON SIDEWALL 2POLYESTER
4	MOLD No.	12	MAX. LOAD 875kg (1929 LBS) MAX. PRESS. 300kPa (44PSI)
5	225/70R16 103H M+S	13	ECE APPROVAL MARK
6	TREADWEAR 400 TRACTION A TEMPERATURE A	14	DOT 17B KMEEPA
7	TUBELESS	15	SAFETY WARNING
8	MADE IN CHINA		

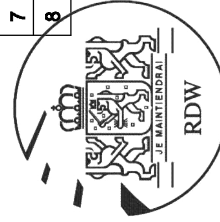

TIRE SIZE	D(mm)	S(mm)	A(mm)	LOAD INDEX SPEED CODE	REMARK
225/70R16	722	228	165	103H	

SCALE : FREE	DATE : 2019.4.11	DESIGNED BY Cheng Yongchao	CHECKED BY Xie Baoshan	APPROVED BY Shen Maoqiao	DRAWING NO.
SHANDONG LONGYUE RUBBER CO., LTD.			TITLE 225/70R16 103H		

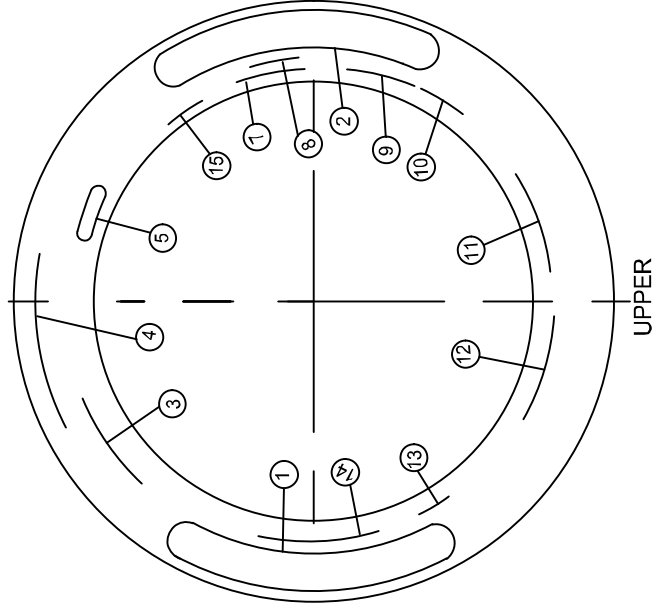
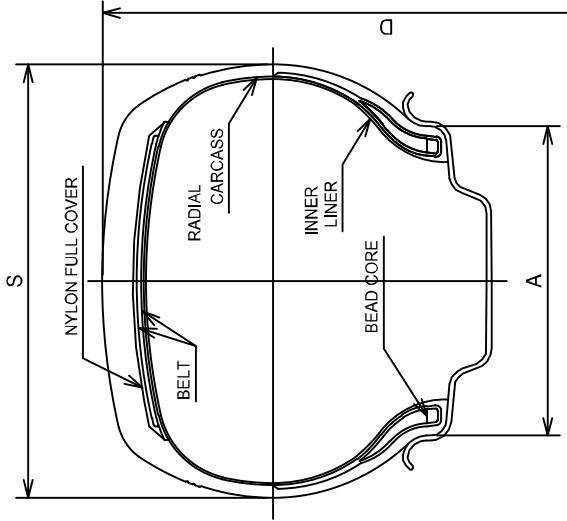

UPPER

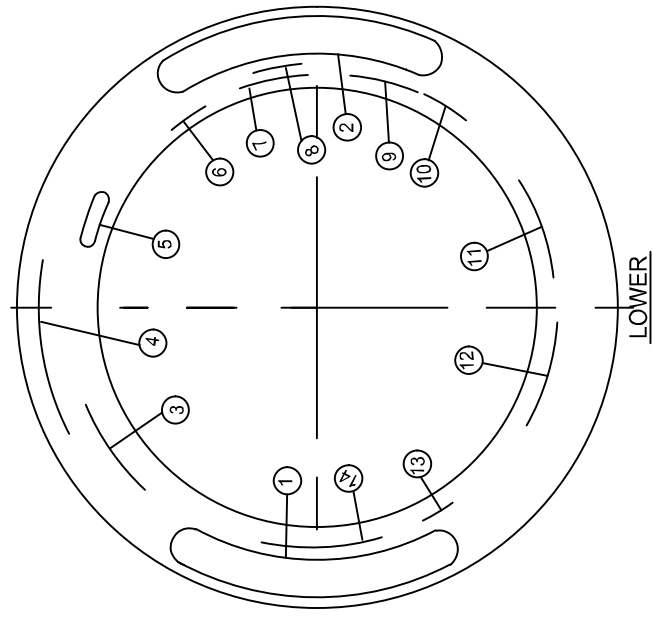

LOWER

TREAD PATTERNS
REFER TO ATTACHMENT NO.11

1	GRENLANDER; ARVID; CONSTANCY; ILINK; LUXIAN; RHINO; CRYSTAL; T TYRE; ROCKBLADE; FRONWAY; SAIL WIN; XBR; ROADMARCH;	9	STEEL BELTED	TUBELESS	RADIAL
2	L788; L-FINDER78; HIGHROAD H/T 78; SPEEDROAD H/T 78; FORZA H/T; INSPIRER F2; GP1000; Rapid; ROCK 788;	10	MADE IN CHINA		
3	SAFETY WARNING	11	PLIES: SIDEWALL 2 POLYESTER TREAD: 2 POLYESTER 2 STEEL+1 POLYAMIDE		
4	TREADWEAR 420 TRACTION A TEMPERATURE A	12	MAX. LOAD 875kg (1929 LBS) MAX. PRESS. 300KPa (44PSI)		
5	ECE APPROVAL MARK	13	M+S		
6	DOT 7BDA BF5 XXXX (DATE CODE)	14	225/70R16 103H		
7	MOLD No.	15	DOT 7BDA BF5		
8	STANDARD RIM: 6 1/2J	16			

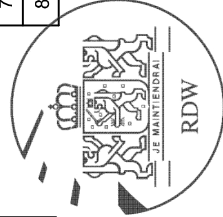

TIRE SIZE	D(mm)	S(mm)	A(mm)	LOAD INDEX	SPEED CODE	REMARK
225/70R16	722	228	165	103H	103H	

SCALE : FREE	DATE : 2019.4.11	DESIGNED BY Cheng Yongchao	CHECKED BY Xie Baoshan	APPROVED BY Shen Maoqiao	DRAWING NO.
SHANDONG LONGYUE RUBBER CO., LTD.			TITLE 225/70R16 103H		

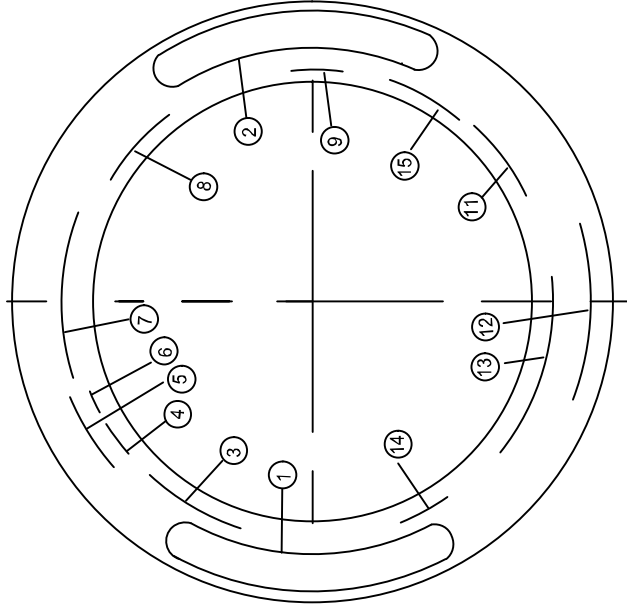
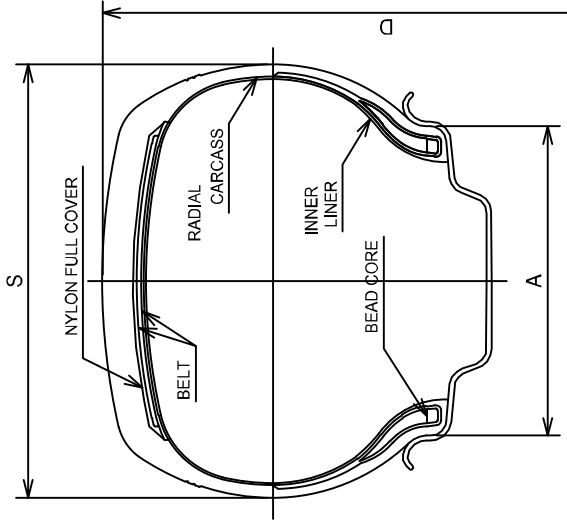

UPPER

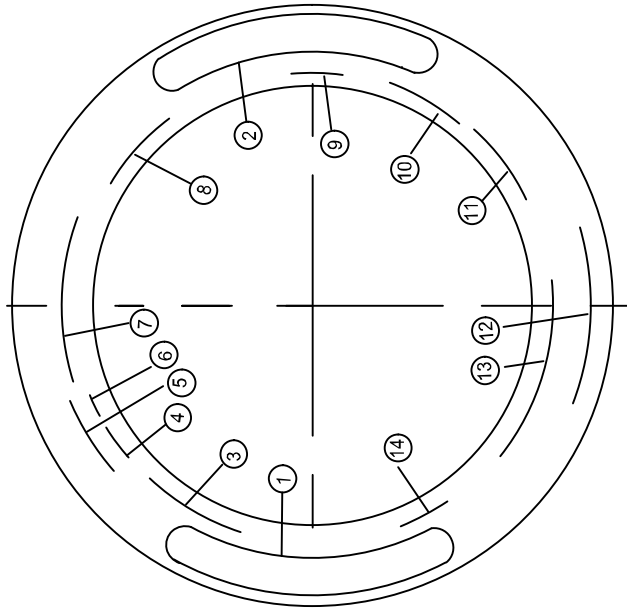

LOWER

TREAD PATTERNS
REFER TO ATTACHMENT NO.11

1	GRENLANDER; ARVID; CONSTANCY; ILINK; LUXXAN; RHIND; CRYSTAL; T TYRE; ROCKBLADE; FRONWAY; SAILWIN; XBR; ROADMARCH;	8	MAX. LOAD 875kg (1929 LBS) MAX. PRESS. 300KPa (44PSI)
2	LY969; L-SNOW99; ICEPOWER 99; ICEWINNER 99; WINTERCROSS ARW7; INSPIRER W8; ROCK 919S;	9	MADE IN CHINA
3	PLIES: TREAD 2POLYESTER+2STEEL+NYLON SIDEWALL 2POLYESTER	10	DOT 17B XXXXX XXXX (DATE CODE)
4	RIM 6 1/2 J	11	ECE APPROVAL MARK
5	RADIAL TUBELESS	12	ROTATION
6	MOLD No.	13	SAFETY WARNING
7	225/70R16 103HM+S	14	
		15	DOT 17B XXXXX

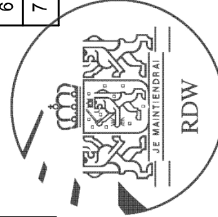

TIRE SIZE	D(mm)	S(mm)	A(mm)	LOAD INDEX	SPEED CODE	REMARK
225/70R16	722	228	165		103H	

SCALE : FREE	DATE : 2019.4.11	DESIGNED BY Cheng Yongchao	CHECKED BY Xie Baoshan	APPROVED BY Shen Maoqiao	DRAWING NO.
SHANDONG LONGYUE RUBBER CO., LTD.			TITLE 225/70R16 103H		

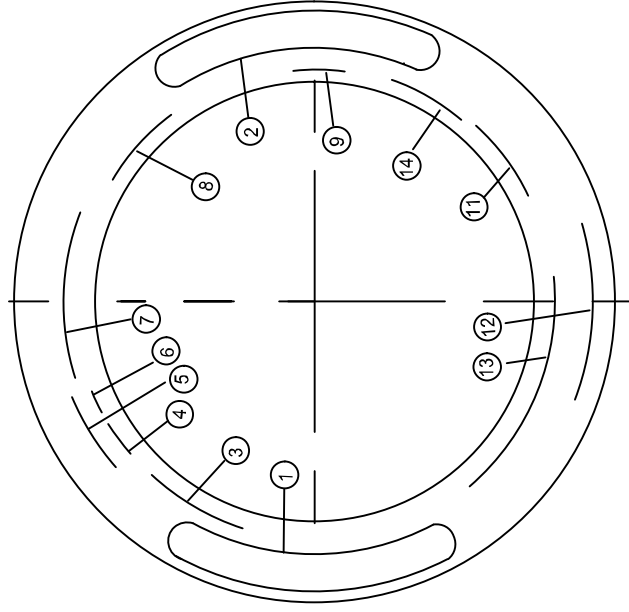
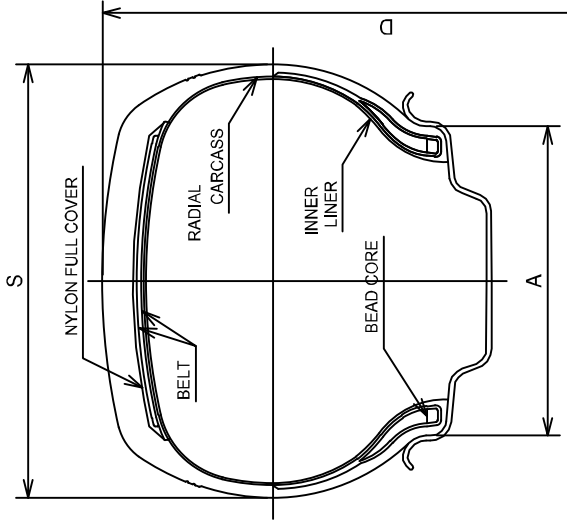

UPPER

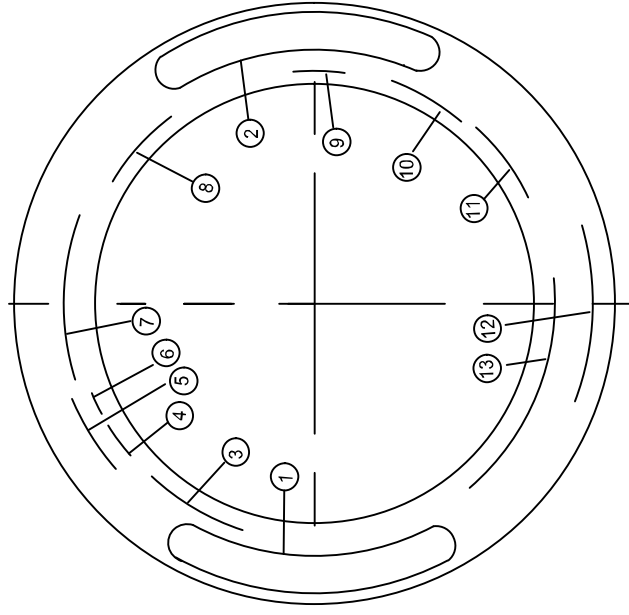

LOWER

TREAD PATTERNS

REFER TO ATTACHMENT ND.11

1	GRENLANDER; ARVID; CONSTANCY; ILINK; LUXXAN; RHIND; CRYSTAL; T TYRE; ROCKBLADE; FRONWAY; SAIL WIN; XBRJ;ROADMARCH;	8	MAX. LOAD 875kg (1929 LBS) MAX. PRESS. 300KPa (44PSI)
2	COLO H01; PREMIO ARZ1; THREE; L-GRIP66; LY168; ECOGREEN 66; VENUSAIR 66; ECOLOGY; INSPIRER C4; ROCK 515; Energize; PRIMESTAR 66;	9	MADE IN CHINA
3	PLIES:TREAD 2POLYESTER+2STEEL+NYLON SIDEWALL 2POLYESTER	10	DOT 17B XXXXXX XXXX (DATE CODE)
4	RIM:6½J	11	ECE APPROVAL MARK
5	RADIAL TUBELESS	12	TREADWEAR 420 TRACTION A TEMPERATURE A
6	MOLD No.	13	SAFETY WARNING
7	225/70R16 103H M+S	14	DOT 17B XXXXXX

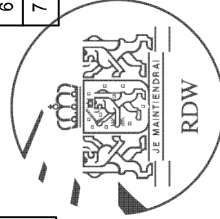

TIRE SIZE	D(mm)	S(mm)	A(mm)	LOAD INDEX	SPEED CODE	REMARK
225/70R16	722	228	165	103H	103H	

SCALE : FREE	DATE : 2019.4.11	DESIGNED BY	CHECKED BY	APPROVED BY	DRAWING NO.
SHANDONG LONGYUE RUBBER CO., LTD.		Cheng Yongchao	Xie Baoshan	Shen Maoqiao	
			TITLE		225/70R16 103H

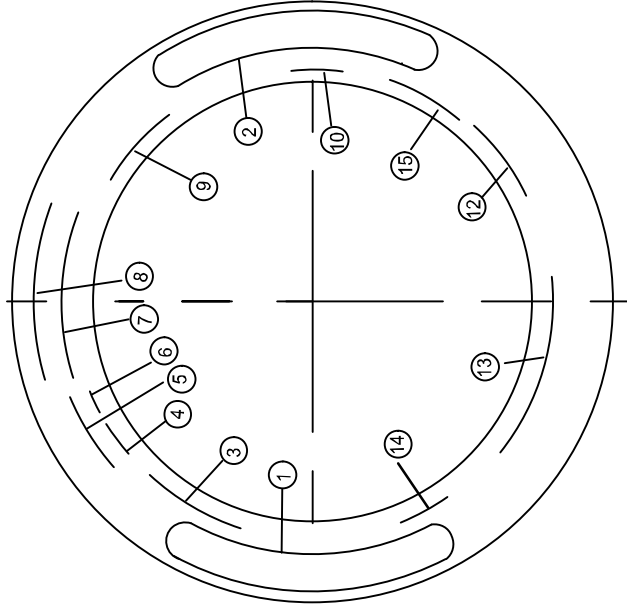
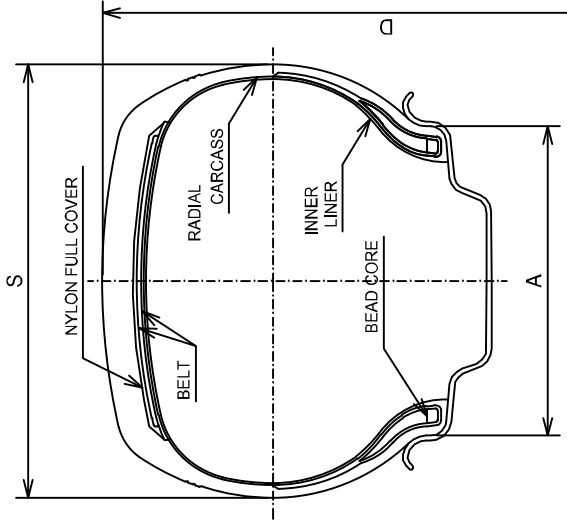

UPPER

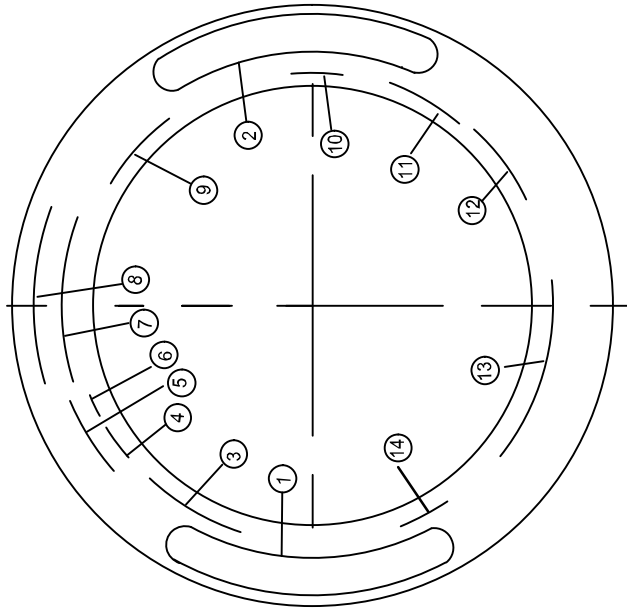

LOWER

TREAD PATTERNS

REFER TO ATTACHMENT NO.11

1	GRENLANDER; ARVID; CONSTANCY; ILINK; LUXAN; RHINO; CRYSTAL; T TYRE; ROCKBLADE; FROWNAY; SAIL WIN; XBR; ROADMARCH;	8	ROTATION
2	GREENWING A/S; MULTIMATCH A/S; FROWNING A/S; EREMATCH A/S; SICAPLORFUL A/S; SPRIME A/S; INSPIRER A/S; JIFORTY ONE; ROCK A/S; ONEEL	9	MAX. LOAD 875kg (1929 LBS) MAX. PRESS. 300KPa (44PSI)
3	PLIES: TREAD 2POLYESTER+2STEEL+1NYLON SIDEWALL 2POLYESTER	10	MADE IN CHINA
4	RIM: 6 $\frac{1}{2}$	11	DOT 17B XXXXX XXXX (DATE CODE)
5	RADIAL TUBELESS	12	ECE APPROVAL MARK
6	MOLD No.	13	SAFETY WARNING
7	225/70R16 103H M+S	14	ALL SEASONS
		15	DOT 17B XXXXX

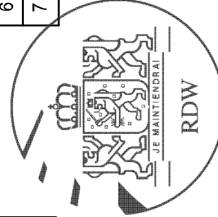

TIRE SIZE	D(mm)	S(mm)	A(mm)	LOAD INDEX	SPEED CODE	REMARK
225/70R16	722	228	165	103H	103H	

SCALE : FREE	DATE : 2019.4.11	DESIGNED BY	CHECKED BY	APPROVED BY	DRAWING NO.
SHANDONG LONGYUE RUBBER CO., LTD.		Cheng Yongchao	Xie Baoshan	Shen Maoqiao	
			TITLE	225/70R16 103H	

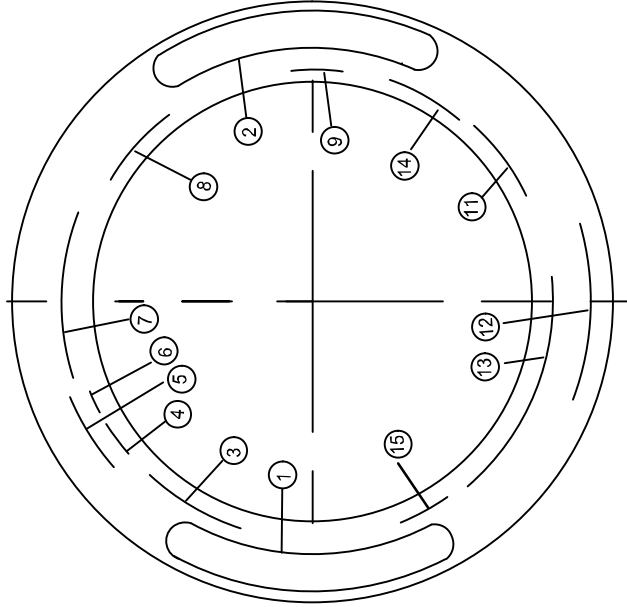
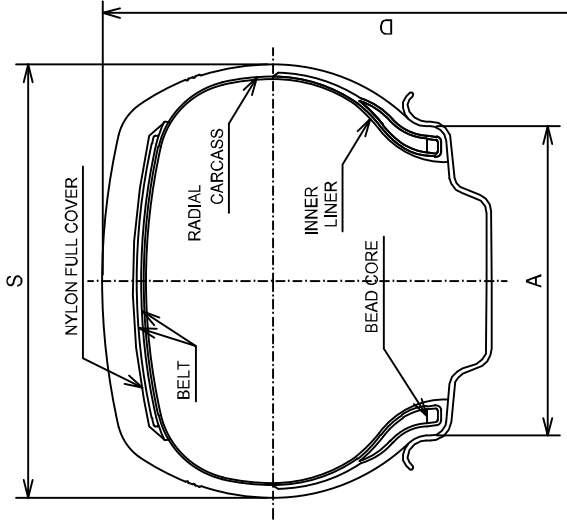

UPPER

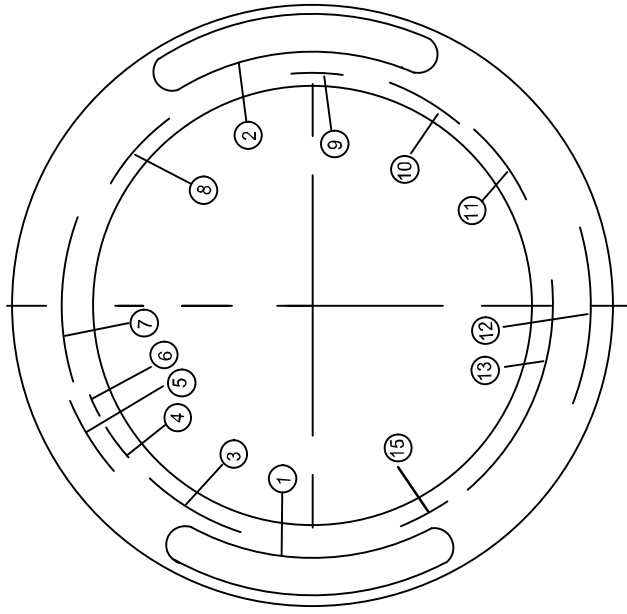

LOWER

TREAD PATTERNS

REFER TO ATTACHMENT NO.11

1	GRENLANDER; ARVID; CONSTANCY; ILINK; LUXXAN; RHINO; CRYSTAL; T TYRE; ROCKBLADE; FRONWAY; SAIL WIN; XBR; ROADMARCH;	8	MAX. LOAD 875kg (1929 LBS) MAX. PRESS. 300KPa (44PSI)
2	Winter Gl 868; WINMASTER ARW2; LY868; Winter IL868; SNOWROVER 868; ROCK 868; SICEPOWVER 868; ICEWINNER 868; INSPIRER W20THIRTY TWJ	9	MADE IN CHINA
3	PLIES: TREAD 2POLYESTER+2STEEL+1NYLON SIDEWALL 2POLYESTER	10	DOT 17B XXXXX XXXX (DATE CODE)
4	RIM: 6½"	11	ECE APPROVAL MARK
5	RADIAL TUBELESS	12	OUTSIDE(LOWER)/INSIDE(UPPER)
6	MOLD No.	13	SAFETY WARNING
7	225/70R16 103H M+S	14	DOT 17B XXXXX
		15	

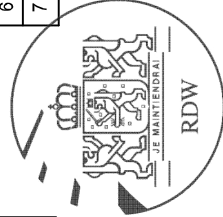

TIRE SIZE	D(mm)	S(mm)	A(mm)	LOAD INDEX	REMARK
225/70R16	722	228	165	103H	

SCALE : FREE	DATE : 2019.4.11	DESIGNED BY	CHECKED BY	APPROVED BY	DRAWING NO.
SHANDONG LONGYUE RUBBER CO., LTD.		Cheng Yongchao	Xie Baoshan	Shen Maoqiao	
			TITLE	225/70R16 103H	

TIRE SIZE 225/70R16 103H

ATTACHMENT NO.11

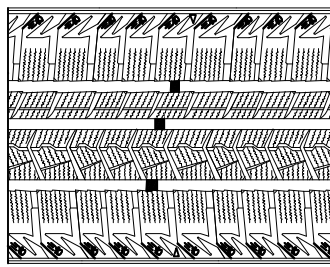
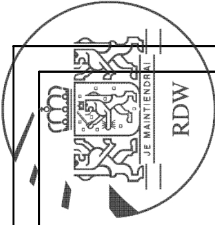

Winter GL868Winter L868;
LY868ICEPOWER 868
ICEWINNER 868WINMASTER ARW2
ROCK 868S THIRTY TWD;
SNOWDRIVER 868;
INSPIRER V20

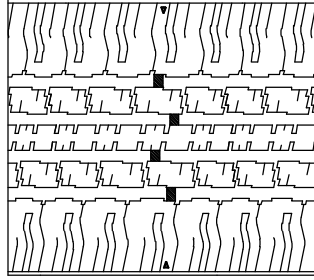

LY789L-FINDER78;
FORZA H/T JGP1000;
HIGHROAD H/T 78;
SPEEDROAD H/T 78;
INSPIRER F2Rapidi
ROCK 788

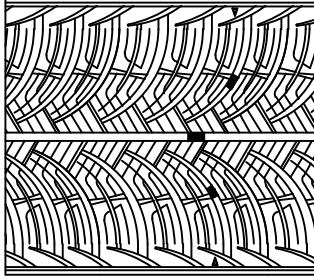

GREENING A/S;
MULTIMATCH A/S;
FRONVING A/S;
FREIMATCH A/S;
Carlor-Ful A/S/PRIME
A/S;
INSPIRER A/S Ij
FORTY DNE;
ROCK A/S DNE

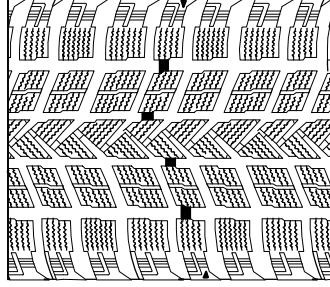

LY969L-SNOW99;
VINTERCROSS ARW7;
INSPIRER V8;
ICEPOWER 99;
ICEWINNER 99ROCK 919S

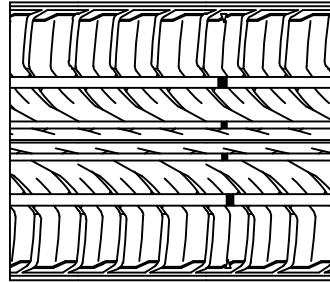

GOLD HOUL-GRIP66;
LY168ECCOGREEN 66;
VENUSATR 66EnerGzej
PREMID ARZIECLOGY;
INSPIRER C4THREE;
ROCK 515PRIMESTAR 66

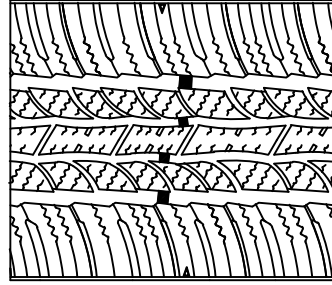

MAHO 77POWERCITY 77;
TOPOVER B7 H/T;
ROADPOWER H/T;
ROADKING H/TMaxim;
TERRAND ARV H/T;
FORZA H/T2 ;
INSPIRER F4TWENTY TWD;
ROCK 717 H/T;
PRIMEWARCH H/T 77

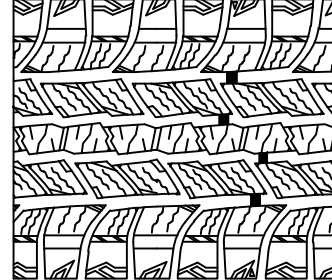

MAGA A/T DNEFORZA A/T;
TERRA MAX LSR1 A/T;
TERRA XPLORER C1 A/T;
GLADIATAX A/T Ij
ROCKBLADE A/T Ij
TERRAMAX ARV A/T;
INSPIRER A/T Ij
TOUGH TRAC A/T Ij
ROCK 727 A/T;
PRIMEWARCH A/T I

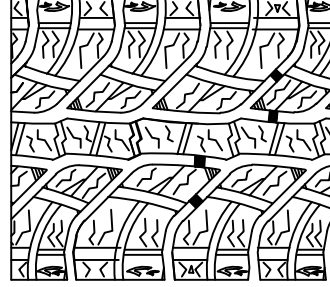

MAGA A/T TWDFORZA A/T2;
TERRA MAX LSR2 A/T;
TERRA XPLORER C2 A/T;
GLADIATAX A/T II;
ROCKBLADE A/T II;
TERRAMAX ARV PRO A/T;
INSPIRER A/T II;
TOUGH TRAC A/T II;
ROCK 737 A/T;
PRIMEWARCH A/T II

6 TREAD WEAR INDICATORS EQUALLY SPACED

DRAWN BY

Cheng Yongchao

CHECKED BY

Xie Baoshan

APPROVED BY

Shen Maoqiao

SHANDONG LONGYUE RUBBER TYRE CO.,LTD.