

# BACKHOE BHSM Series

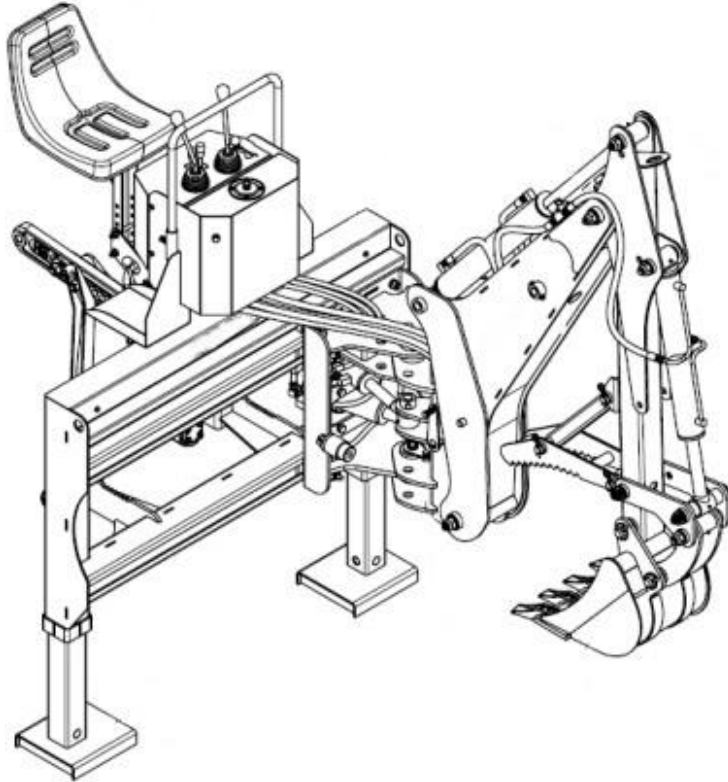

---

# TABLE OF CONTENTS

	PAGE
<b>GENERAL INFORMATION</b>	4
<b>CHAPTER 1. SAFETY PRECAUTIONS</b>	5
1.1 SAFETY	5
1.2 SAFETY PRECAUTIONS	6
<b>CHAPTER 2. SAFETY DECALS</b>	8
<b>CHAPTER 3. BACKHOE SPECIFICATIONS</b>	11
3.1 DIGGING DIAGRAM	12
3.2 HYDRAULIC SYSTEM MAIN COMPONENT	13
3.3 BACKHOE MAIN COMPONENTS	14
<b>CHAPTER 4. ASSEMBLY INSTRUCTIONS</b>	15
<b>CHAPTER 5. TRACTOR PREPARATION</b>	35
5.1 HYDRAULIC SYSTEM	35
5.2 TYRE INFLATION	35
5.3 WHEEL TREAD SETTINGS	35
5.4 ATTACHMENT	36
5.5 COUNTER WEIGHT	36
<b>CHAPTER 6. BACKHOE OPERATION</b>	37
6.1 PRECAUTIONARY NOTE	37
6.2 INITIAL BACKHOE OPERATION	39
6.4 BACKHOE HYDRAULIC CONTROLS	40

<b>6.5 STABILIZER CLIPS</b>	<b>41</b>
<b>6.6 OPERATING HYDRAULIC SIDE SHIFT</b>	<b>41</b>
<b>CHAPTER 7. MAINTENANCE</b>	<b>44</b>
<b>CHAPTER 8. TROUBLE SHOOTING</b>	<b>47</b>
<b>CHAPTER 9. PARTS CATALOGUE</b>	<b>53</b>
<b>9.1 FRONT ARM</b>	<b>54</b>
<b>9.2 MAIN BOOM</b>	<b>56</b>
<b>9.3 SWING JOINT</b>	<b>57</b>
<b>9.4 MAIN FRAME</b>	<b>60</b>
<b>9.5 SUPPORTING LEG</b>	<b>63</b>
<b>9.6 SEAT</b>	<b>64</b>
<b>9.7 HYDRAULIC UNIT</b>	<b>65</b>
<b>9.8 CONTROL VALVE</b>	<b>69</b>
<b>9.9 PTO CONNECTION</b>	<b>70</b>



---

# GENERAL INFORMATION

---

## **INTRODUCTION:**

The purpose of this manual is to assist you in maintaining and operating your backhoe. Read it carefully, it provides information and instructions that will help you achieve years of reliable performance. Some information may be general in nature due to unknown and varying conditions. However, through experience and these instructions, you should be able to develop operating procedures suitable to your particular situation.

“Right” and “Left” as used throughout this manual are determined by position operator is facing when in use.

The photos, illustrations and data used in this manual are current at the time of printing, but due to possible in-line production changes, your machine may vary slightly in detail. The manufacturer reserves the right to redesign the machine as may be necessary without notification.

### **Important:**

Illustrations used in this manual may not show all safety equipment that is recommended to ensure safe operation of tractor and backhoe. Refer to the Safety Precautions section of this manual for information concerning safety, consult your dealer for further information.

---

# 1 Safety Precautions

---

## 1.1 SAFETY

Understand that your safety and the safety of other persons is measured by how you service and operate this Backhoe.

Know the position and operations of all controls before you they operate. Make sure you check all controls in safe area before starting.

Read this manual completely and thoroughly and make sure you understand all controls. All equipment has a limit. Make sure you are aware of the stability and load characteristics of this Backhoe before you begin operation.

The Safety Information given in this manual does not replace any safety codes, insurance needs, federal, state and local laws. Make sure your machine has the correct equipment required by your local laws and regulations.



This safety alert symbol indicates important safety message in this manual. When you see this symbol, carefully read the message that followings and be alert to the possibility of personal injury or death.



## 1.2 SAFETY Precautions



Before starting the engine of your tractor, make sure all operation controls are in park lock or neutral position.

Operate controls only when seated in the operator's seat.

See your tractor operator's manual for correct usage.

A frequent cause of personal injury or death is persons falling off and being run over. Do not permit others to ride on your tractor. Only one person, the operator, should be on the machine when it is in operation.

Before leaving the tractor, stop the engine, put all controls in neutral, engage the parking brake and remove the key from the ignition.

Operate the backhoe smoothly when lowering or lifting loads.

Stay off of slopes too steep for safe operation. Shift down before you start up or down a hill with heavy load. Avoid "free wheeling"

Travel speed should be such that complete control and machine stability is maintained at all times. Where possible, avoid operation near ditches, embankments and holes. Reduce speed when turning, crossing slopes, and on rough, slick or muddy surfaces.

Never use your hand to check for suspected leaks under pressure. Use a piece of cardboard or wood for this purpose. Escaping hydraulic oil or diesel fuel leaking under pressure can have sufficient force to penetrate the skin and cause infection or other injuries. If this happens seek medical attention immediately.

To prevent personal injury, relieve all pressure before disconnecting fluid lines.

Before applying hydraulic pressure, make sure all hydraulic connections are tight and components are in good condition.

Contact with overhead power lines can cause severe electrical burn or electrocution.

Make sure there is enough clearance between raised equipment and overhead power lines.

Add water to rear tires or rear wheel weights for increased stability.

---

A backhoe attachment should be transported in a low position at slow ground speeds. Make turns slowly and use the tractor brakes cautiously. A loaded attachment in the raised position alters the center of gravity location of the machine and increases the possibility of mishaps.

Do not stand, walk or work under a raised backhoe attachment unless it is securely blocked or mechanically in position. Accidental movement of a control lever or leak in the hydraulic system could cause the backhoe to drop, or attachment to dump, causing severe injury.

Make sure all parked backhoe on stands are on a hard level surface with all safety devices engaged to prevent backhoe from falling and being damaged or injuring someone.

When using a backhoe, be alert of bucket, boom and arm position at all times.

Only operators who have been specially trained in backhoe operation and fully understand this manual can operate the backhoe.

Keep hands, feet and clothing away from all moving parts. Wear close fitting clothing and appropriate safety equipment (Which includes, steel cap shoes, protective gloves, hard hat, safety glasses and dusk mask). Prolonged exposure to loud noise can damage hearing. Wear suitable approved hearing protection such as ear muffs or plugs. Operating equipment safely requires your full attention. Do not wear radio or music headphones. Secure hair above shoulder length.

You must be in good physical and mental health to operate the backhoe safely. Do not operate the backhoe when you are ill, fatigued or under the influence of any substance or medication that could affect your vision, co-ordination or judgment.



---

## 2 Safety Decals

---

### Safety Decals

- Keep safety decals clean and free of obstructing material
- Replace damaged or missing safety decals with new decals from your dealer.
- If a component with a safety decal(s) affixed is replaced with a new part, ensure new safety decal(s) are attached in the same locations on the replacement components.

Refer below for summary of decals. Note decals appear on both sides of backhoe.



6.



7.



8.

## Warning! High Pressure Fluid

**HIGH PRESSURE FLUID HAZARD**

- Relieve pressure on hydraulic system before servicing or disconnection hoses.
- Wear proper hand & eye protection when searching for leaks. Use wood or cardboard instead of hands.
- Keep all components in good repair.

9.

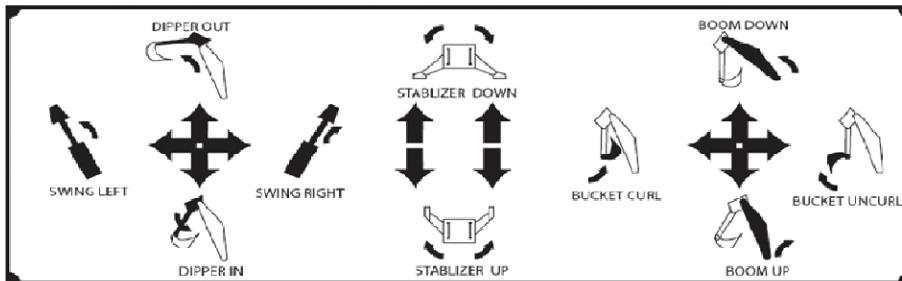

10.



11.



12.



13.



14.



15.



---

## 3 Backhoe Specifications

---

<b>Model</b>	<b>BHSM 175</b>	<b>BHSM 195</b>	<b>BHSM 225</b>
Dimension (LxWxH) (mm)			
Structure weight (kg)	520	550	750
Max digging depth (m) A	2.6	2.9	3.3
Max digging radius (m) B	1.75	1.85	2.25
Max height (m) C	3.12	3.17	3.45
Max unloading height (m) D	1.8	2	2.3
Stabilizer width (m)	1.7	1.7	1.7
Swing angle for boom	180	180	180
Bucket turning angle	195	195	203
Bucket capacity of standard bucket (m <sup>3</sup> )	0.02	0.025	0.035
Bucket width (mm)	300	400	500
Bucket Digging Force (kg)	1100	1100	1700
Dipper Arm Digging Force (kg)	850	850	1100

### 3.1 DIGGING DIAGRAM

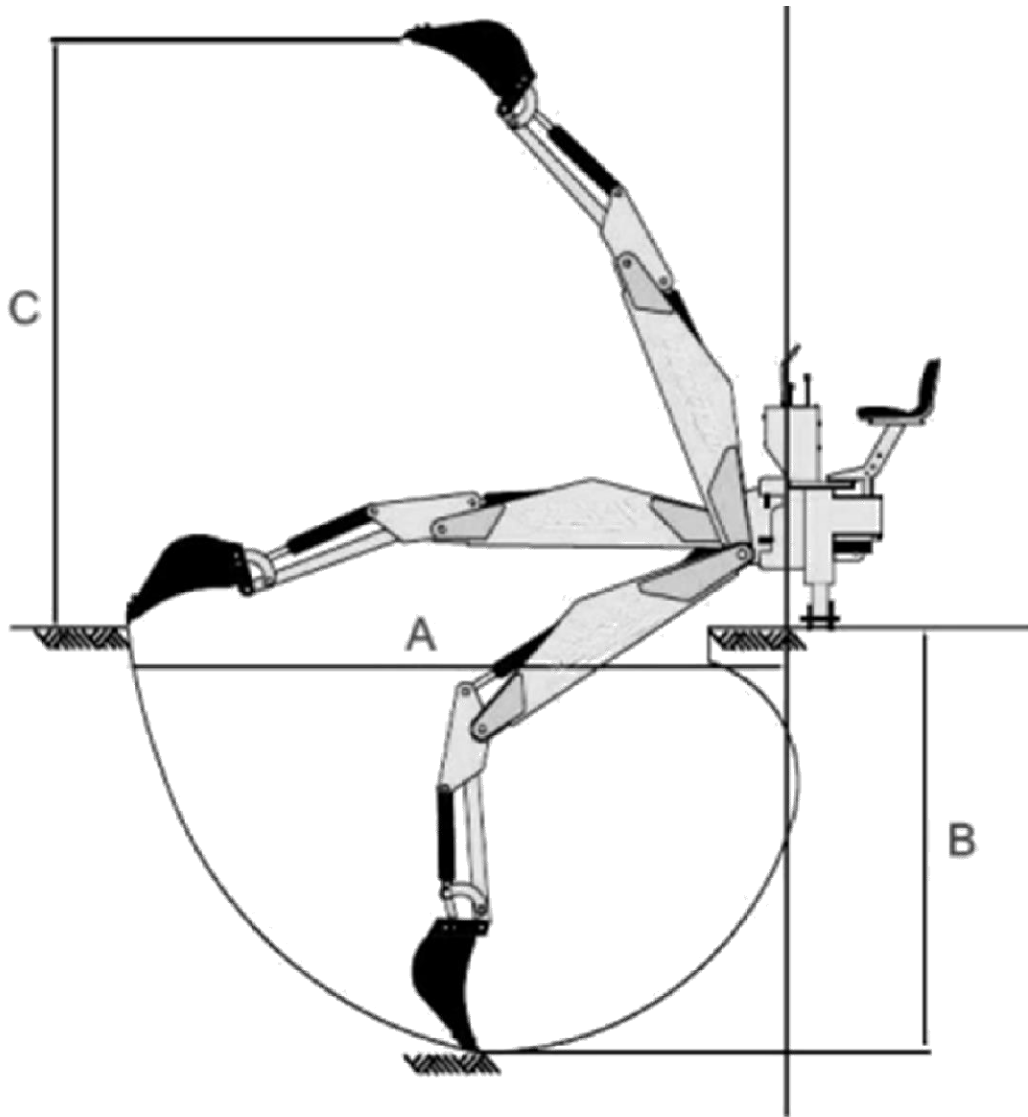

### 3.2 HYDRAULIC SYSTEM MAIN COMPONENT

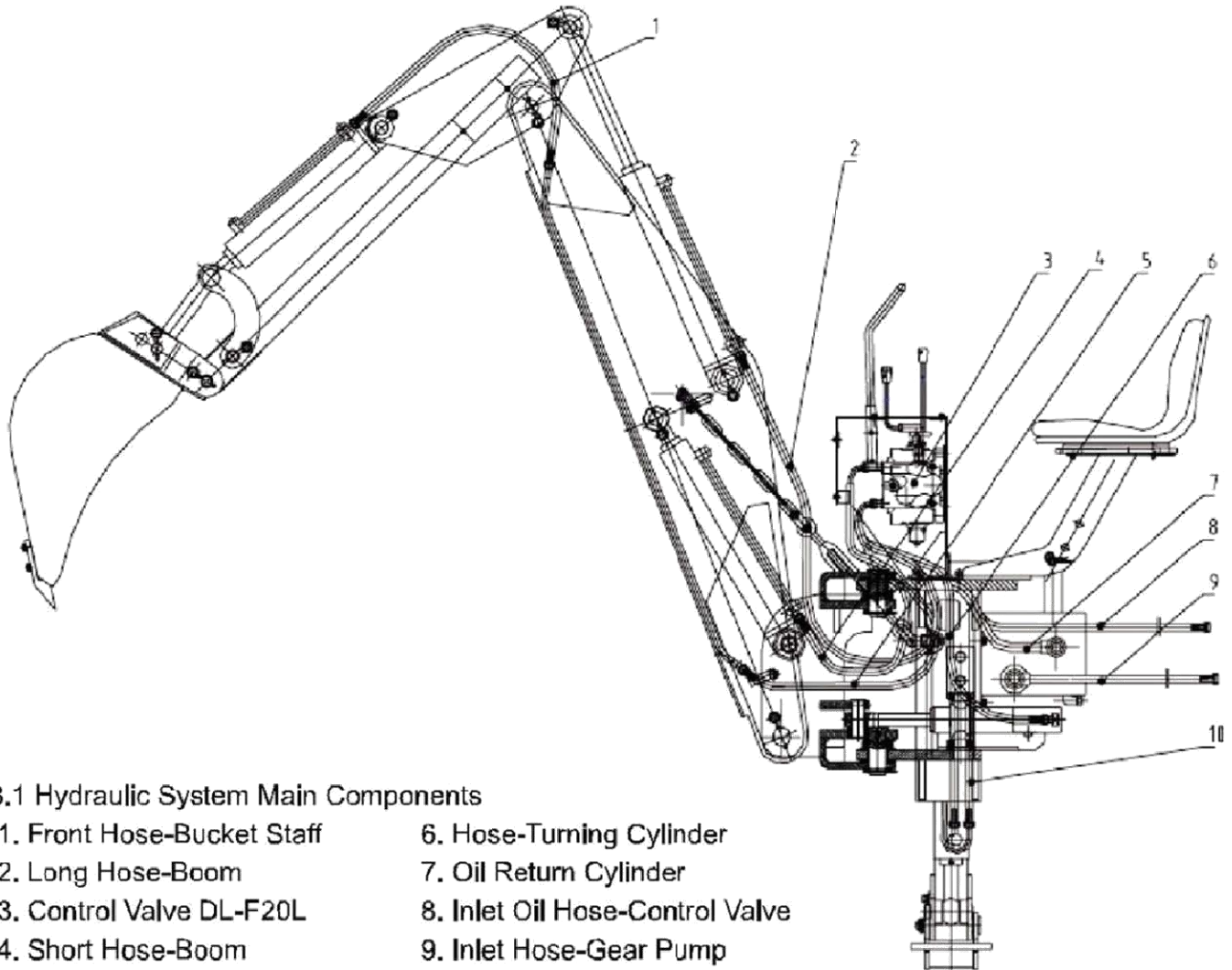

#### 3.1 Hydraulic System Main Components

- |                            |                                 |
|----------------------------|---------------------------------|
| 1. Front Hose-Bucket Staff | 6. Hose-Turning Cylinder        |
| 2. Long Hose-Boom          | 7. Oil Return Cylinder          |
| 3. Control Valve DL-F20L   | 8. Inlet Oil Hose-Control Valve |
| 4. Short Hose-Boom         | 9. Inlet Hose-Gear Pump         |
| 5. Rear Hose-Bucket Staff  | 10. Hose-Stabilizer             |

### 3.3 BACKHOE MAIN COMPONENTS

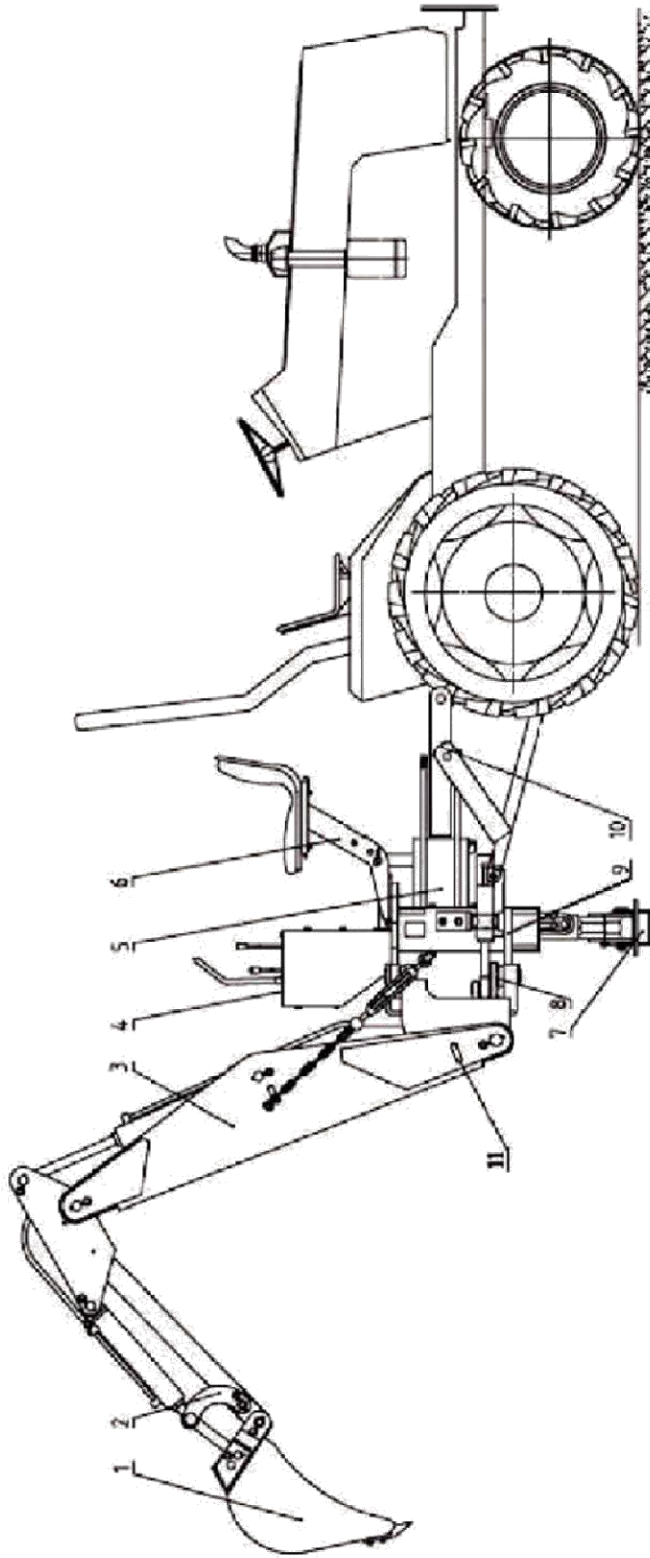

#### 3.2 Backhoe Main Components

- |                        |                     |
|------------------------|---------------------|
| 1. Bucket              | 7. Stabilizer       |
| 2. Bucket Staff        | 8. Swing Post       |
| 3. Boom                | 9. Bottom Seat      |
| 4. Bracket for Control | 10. Sub A Frame     |
| 5. Tank                | 11. Safety Lock Pin |
| 6. Seat                |                     |

## 4 Assembly instructions

Read and ensure you understand the **full** assembly instructions **before** you begin construction. Only remove the transport frame when the assembly instructions say to do so.

The machine is delivered from the factory in transport configuration. Always use suitably sized tools, appliances and lifting equipment with adequate power for assembly. Two people are always required for lifting, moving and assembling the machine. Wear suitable protective clothing such as safety shoes and protective gloves. Check that all screws and nuts are fitted correctly when assembling the machine. Take care when opening the accompanying boxes as hard additional parts are inside.

Before starting to assemble the machine, please observe the following instructions:

- Clear the area beforehand of people standing in the vicinity, particularly children.
- Use a forklift truck to move or lift the palette/machine.
- Keep the load close to the ground.
- Move the machine to the assembly site
- Ensure there is enough room to safely assemble the machine and access the machine from all sides.

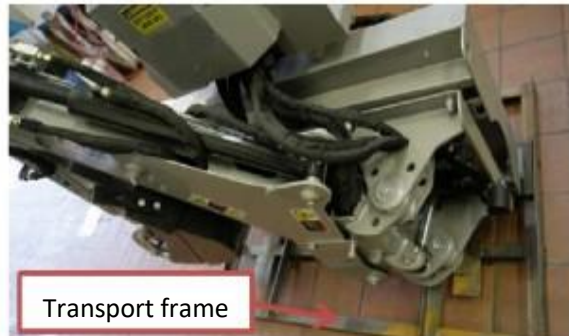

Fig.1 Rear digger transport configuration



Fig.2 Rear digger transport configuration



Fig.3 Accessories and fasteners



Fig. 4 Fasteners



**Important notices:**

**Before** beginning assembly, read the **full assembly instructions** through and familiarise yourself with the individual stages of assembly **in advance**. This is **very** necessary as the assembly stages build on each other logically and failing to follow the order that the steps go in can lead to components of the rear digger being damaged.

Make sure that the rear digger is standing securely at all times during assembly. This applies especially if the rear digger has not yet been attached to the tractor's 3-point chassis.

**Important:** Only loosen the screws on the transport frame when the assembly instructions say to do so!

The rear digger is delivered **without hydraulic fluid**. Further information on the necessary advance filling and monitoring of the hydraulic fluid level is given later in these operating instructions. Never operate the rear digger without enough hydraulic fluid.

In rare cases you may find that the control directions on the operating unit label are **not** in compliance with the actual directions for hydraulic movements when operating the digger.

When you first operate the digger, move the lever very slowly and keep constant control of the directions of movement. This also applies to the first removal and fixing of the transport frame to manoeuvre the rear digger to a safe assembly position during

initial assembly.

Always secure the rear digger with the transport frame between different places of use to avoid accidents.

Remember not to remove the lower transport frame before the instructions say to do so to categorically rule out the chance of the rear digger falling over and thereby avoid serious injuries and accidents.



Fig.5 Left side of safety frame



Fig.6 Right side of safety frame

## Assembly

### 1. Testing

Check all of the hydraulic pipes for correct assembly, leakage and correct position. Check all screws for correct and secure positioning.

### 2. Filling and monitoring hydraulic fluid

Fill up the hydraulic fluid and check that it is at the correct level in the viewing glass. Figure 7 shows the unscrewed inward screws with valve. If possible, fill the hydraulic fluid up in this way. If the openings are too small, unscrew the cover as shown in Figure 8 and fill the oil up to the correct level on the viewing glass. Put the screws to one side so that they do not accidentally fall into the tank.

### 3. Remove the retaining strap

Remove the retaining strap, where available, from the excavator arm (Figure 10).

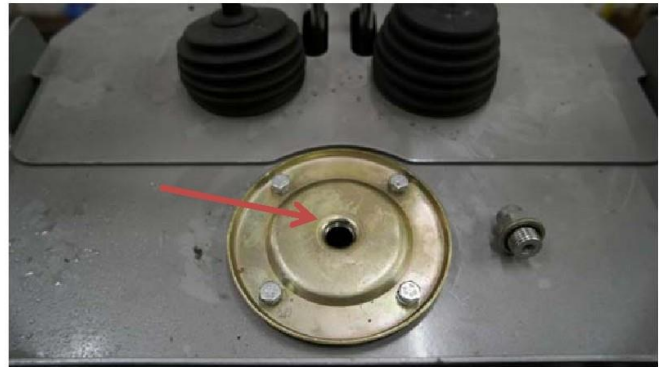

Fig.7 Filling hole



Fig.8 Filling hole (alternative)



Fig.9 Hydraulic fluid level viewing glass



Fig.10 Retaining strap

#### 4. Lubricate the universal joint

Lubricate the lubrication nipple of the universal joint on both sides (Figure 11).

#### 5. Secure the weighing frame

Secure the protector for the universal joint to the digger. To do this, loosen the screws on the hydraulic pump as far as enables the protector to be pulled away (Figures 12 to 14). Then tighten the screws again.



Fig.11 Lubricating the universal joint



Fig. 12 Weighing frame universal joint on the digger



Fig. 13 Hydraulic pump shaft on the digger

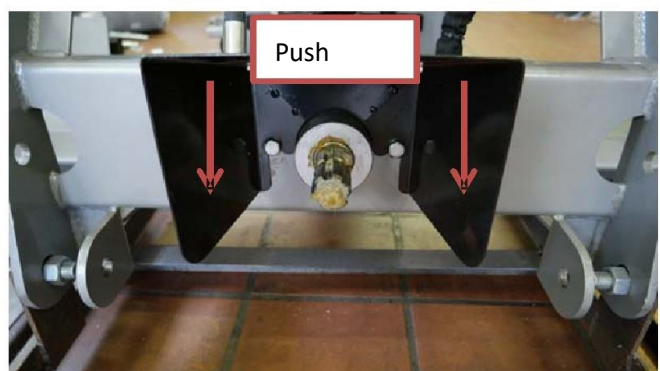

Fig. 14 PTO cover attached to the digger

---

## 6. Connecting and securing the universal joint

Fix the universal joint to the hydraulic pump shaft. Secure the universal joint protector with the chain (Figure 15). Slowly drive the tractor up to the rear digger and fix the universal joint and safety chain to the tractor. Run the universal joint carefully without using the accelerator. Take care to meet all of the tractor's relevant safety requirements and follow its operating instructions.



Fig.15 Universal joint with safety chains

7. Prepare the transport supports for digger operation.

**Warning:** Only adjust the transport frame on both sides of the excavator arm if you understand the functions on the label (Figure 17) and operating unit (Figure 16). The excavator arm must be raised very slightly for correct adjustment of the transport frame. **Do not lower the excavator arm** as otherwise the frame will be destroyed. Complete this step with 2 people to ensure that you can always keep an eye on the transport frame. You **may** also find that the excavator arm is secured with heavy loop bolts for transport. Remove these before using the operating unit.

- Lift the excavator arm very slightly to release the transport frame (Figure 18).
- Then switch the frame to operational mode as shown in Figure 19.

**Important:** There are 2 transport frames, one on each side of the digger. Check whether the other frame is still in a secured position. If so, carry on exactly as shown in Figures 18 and 19 for the side that is left of the digger when driving.



Fig.16 Control unit

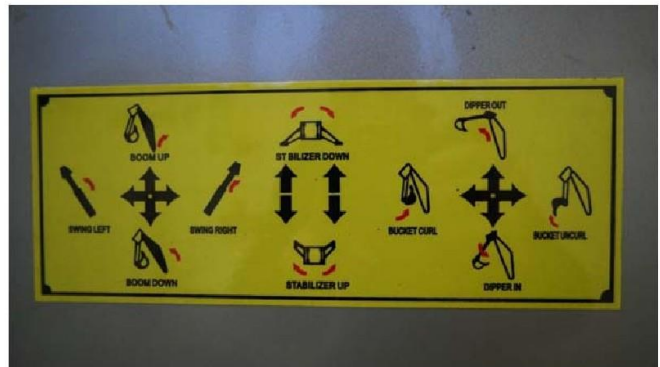

Fig.17 Functional label (example)

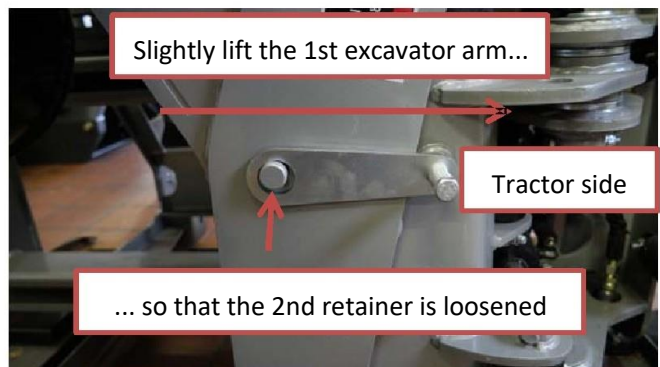

Fig.18 Frame in transport configuration

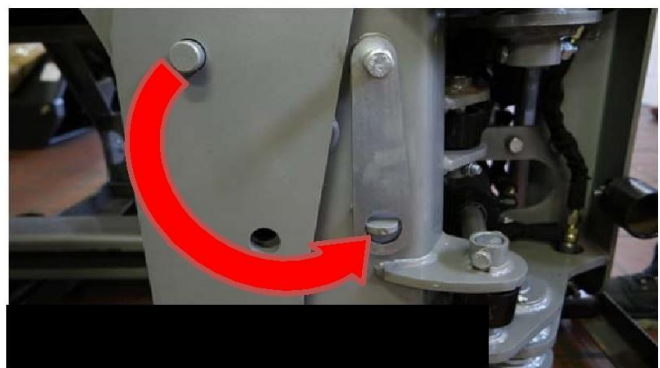

Fig.19 Frame in operational configuration

8. Aligning the excavator arm centrally and safely setting it up

- Then remove the protective sleeves for the hydraulic cylinder (Fig.20).

-Then switch on the hydraulic lateral displacement by moving the lever to the right (Figure 22).

- Align the digger centrally

- Switch the hydraulic lateral displacement off (Figure 21).

- Drive the scoop out and settle it on a safe load-bearing base so as to ensure there is a secure base for further assembly as shown in Figure 24.



Fig.20 Removing the protective sleeves

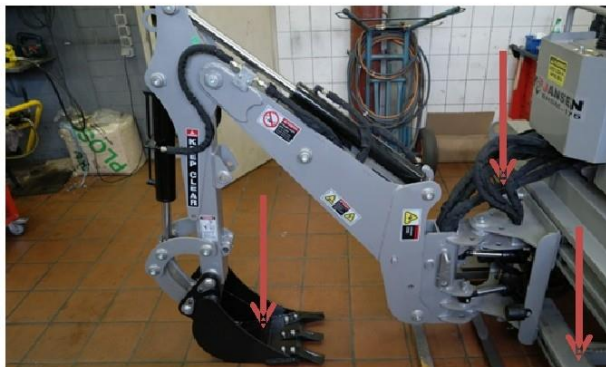

Fig.21 Hydraulic lateral displacement out



Fig.22 Hydraulic lateral displacement in

Fig.24 Stable base for the digger



- Then switch the tractor off and remove the universal joint to assemble the remaining parts.

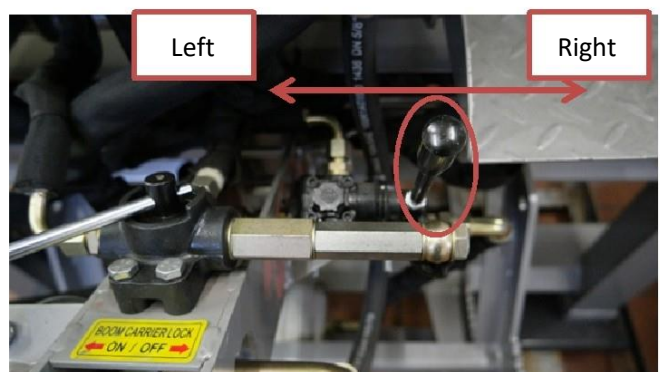

Fig. 23 Lever for lateral displacement

---

## 9. Fixing the rubber pads

Assemble the rubber pads as shown in Figures 25 - 27.

Do this on both sides.



Fig.25 Rubber pads



Fig.26 Stop sleeve



Fig. 27 Assembled rubber pad

## 10. Assembling the driving seat

Put the materials to one side where you can see them as shown in Figure 28.

- Only secure the seat rods as shown in Figure 30 on the third drill hole of the perch. Put the rest of the securing materials to one side.

Arrange the materials for the seat as shown in Figure 31.



Fig.28 Seat rods with screws



Fig. 29 Holes for seat rods



Fig.30 Partially assembled seat rods



Fig.31 Seat with rails and screws



Arrange the materials as shown in Figure 32. Be sure that the right guide rail for horizontal geared seat adjustment is present.

Assemble the guide rails on the panel with the 4 holes (Figure 34)

Place the seat on the guide rails as shown in Figure 35. Use the lever on the side of the seat to help you do this and release the locking function.



Fig. 32 Guide rails

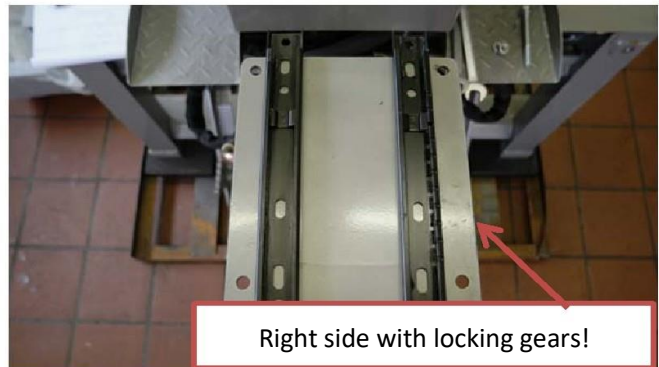

Fig. 33 Seat mounting plate with holes



Fig. 34 Bolted on guide rails

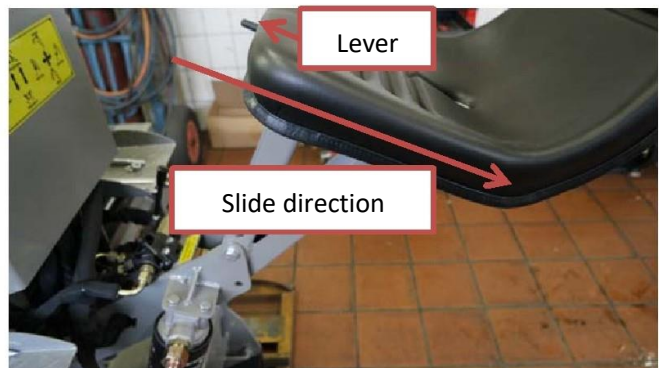

Fig.35 Suspended seat

Now place the seat vertically and screw the screws you set aside earlier in as shown in Figure 36.

The other drill holes can be used for the vertical height adjustment of the seat if this is needed.



Fig.36 Seat with height adjustment

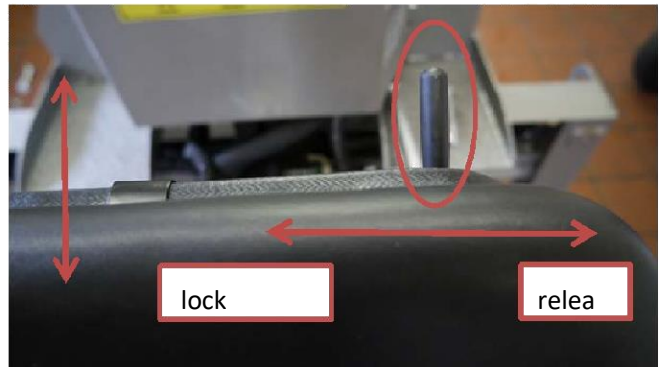

Fig.37 Lock lever for seat adjustment

Figure 37 explains the releasing and stopping of the horizontal seat adjustment process.

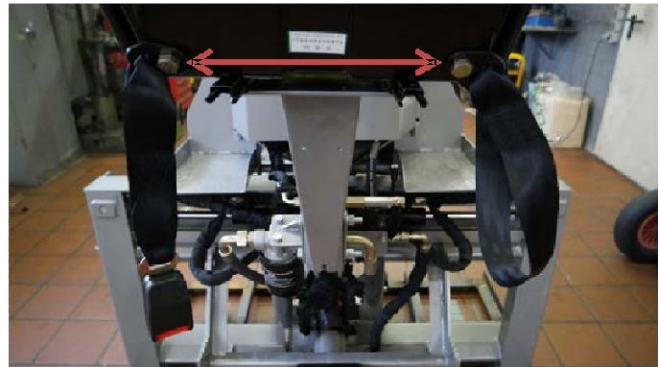

Fig.38 Securing the belt

Then clearly secure the belt as shown in Figure 38 and 39.



Fig.39 Locking the belt on the seat

## 11. Safety bracket

Assemble the safety bracket to the hydraulic tank as shown in Figures 40 to 42.

Use the steps for climbing onto or off of the digger seat (Figure 43).



Fig. 40 Securing left



Fig.41 Securing right



Fig.42 Safety bracket

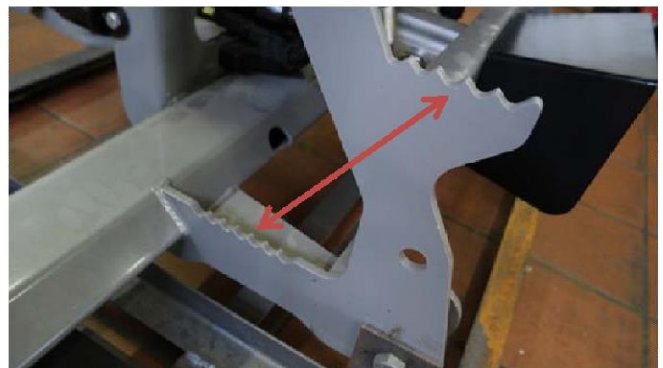

Fig.43 Steps

## 12. Lubricating the gear rack

Loosen both screws as shown in Figure 44 and remove the protective cover.

Lubricate the gear wheel and the gear rack with the lubrication gun (Figure 45).

Secure the protective cover with the two screws again.

### Information:

Lubricating the lubrication nipple is explained later in these assembly instructions.



Fig.44 Protective cover

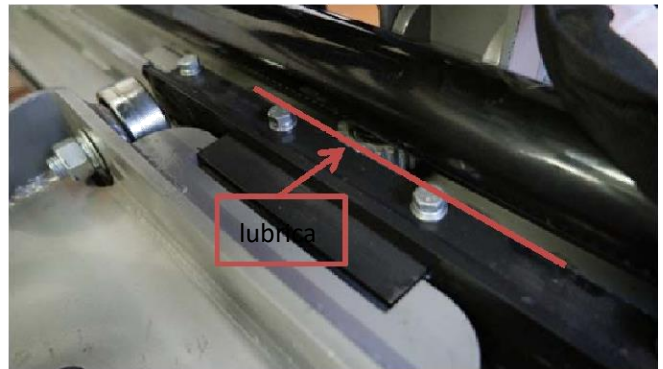

Fig.45 Gear wheel and gear rack

13. Assembling and securing the variable connecting rod / top link

Arrange the materials as shown in Figure 46.

You can vary the connecting rods to correctly connect the top link to the tractor. The digger must be aligned horizontally to lift it later with the 3 point suspension.

Assemble the upper traverse link as shown in Figures 47 and 48. Don't forget the washer and retaining nut.

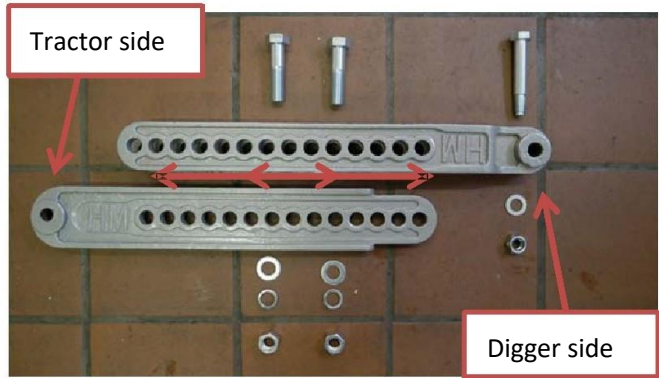

Fig.46 Connecting rods / top links



Fig. 47 Holes for top links on the digger



Fig. 48 Top link assembly on the digger



Fig. 49 Assembled variable connecting rods

#### 14. Assembly on the tractor

##### **Attention!!!**

Observe the safety notices when securing the digger to the 3 point suspension of a tractor. A certain amount of experience is absolutely necessary for this. If you are not familiar with it, always seek help and advice. Adjust the universal joint to the correct size. Observe the corresponding intersection to guarantee error-free operation and the correct transfer of power to the universal joint. Drive the tractor up to the digger and connect the universal joint. Secure the chain of the universal joint protector. Also be aware of the connecting rod assembled in stage 13 to avoid accidents. The connecting rod may need to be secured upwards with a securing material (tensioning strap etc.) to prevent it from unintentionally falling down. Consider the fact that the connecting rod is made from cast iron and weighs over 20 kg.

Now loosen the transport supports and lift the digger carefully and **slightly** with the digger hydraulics so that you can ensure it is **stable** and you can safely insert the two lower securing bolts on the 3-point suspension.

Loosen and remove the universal joint and drive the tractor to the side.



Fig.50 Securing for transport left side



Fig.51 Securing for transport completed



Fig. 52 Bolts are replaceable



Fig. 53 Bolts and splints for lower link

Drive the tractor so that the bolts on both sides can be inserted in the lower link. Don't forget to insert the bolts' splints to avoid the bolts accidentally slipping out.

Then secure the top links to the tractor's suspension (the tractor's bolts are needed for this). When doing this be aware of the horizontal alignment of the rear digger.

Attach the universal joint to the tractor and the rear digger.

Lift the rear digger slightly with the tractor's 3-point suspension and remove the transport frame.

Be very careful not to be crushed by moving parts.



Fig. 54 Bolts and lower traverse link



Fig.55 Left side of the lower traverse link secured with bolts and splints



Fig.56 Right side of the lower traverse link secured with bolts and splints

15. Lubricate the axels and bolts on the digger

Drive the excavator arm out and settle the scoop carefully on a secure base. Carefully drive the two supports out. Turn off the hydraulics and the tractor and secure it against rolling away. Lubricate all 20 lubrication nipples with a lubrication gun. You may find that the excavator arm needs to be moved slightly to reach and lubricate all of the lubrication nipples. You can also lubricate the two supports (Figure 57)

The order of the lubrication nipples in Figures 58 to 77 is shown continuously from the scoop to the drive shaft.

Scoop > Scoop arm > Primary excavator arm > Swivel joint > Drive shaft



Fig.57 Left supports

**Lubrication nipples 1 to 20:**

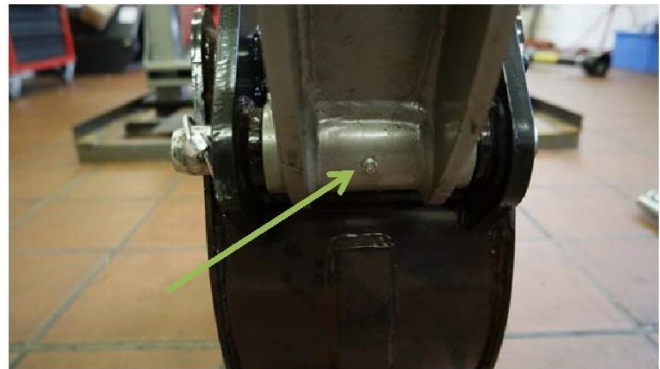

Fig.58 Scoop 1

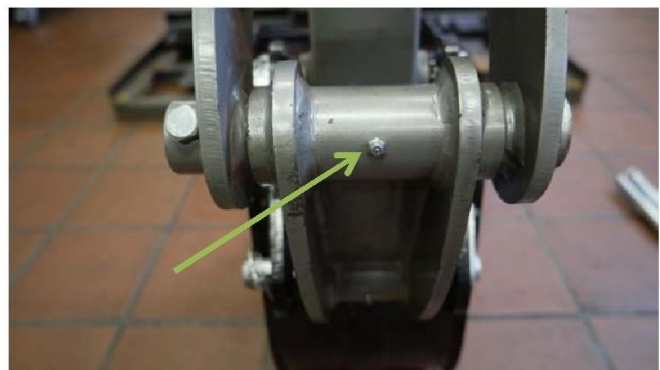

Fig.59 Scoop 2

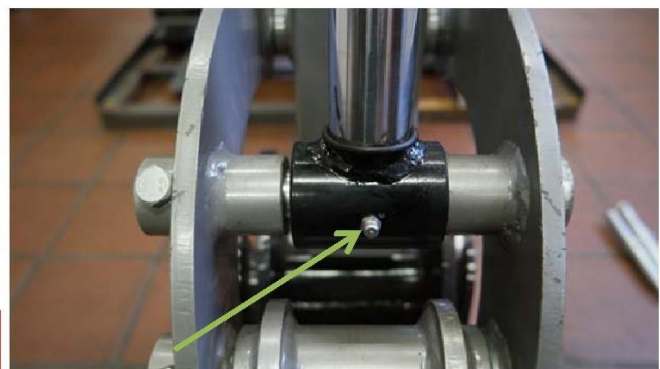

Fig.60 Scoop 3

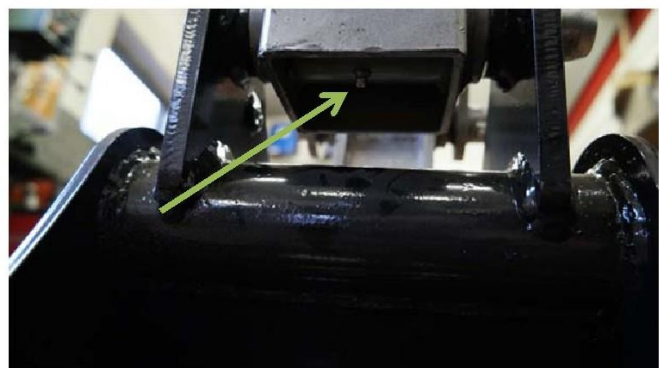

Fig.61 Scoop 4





Fig.62 Scoop 5

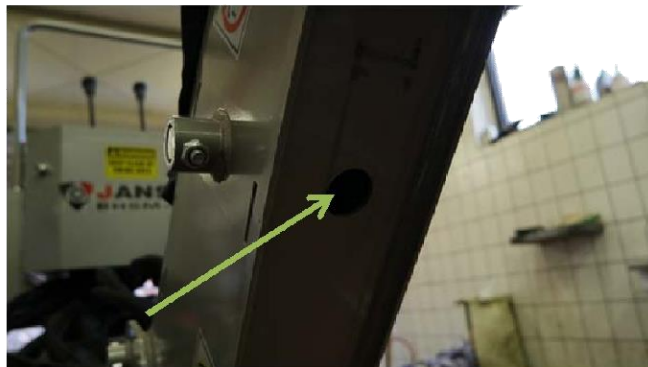

Fig.66 Excavator arm 9



Fig.63 Excavator arm 6

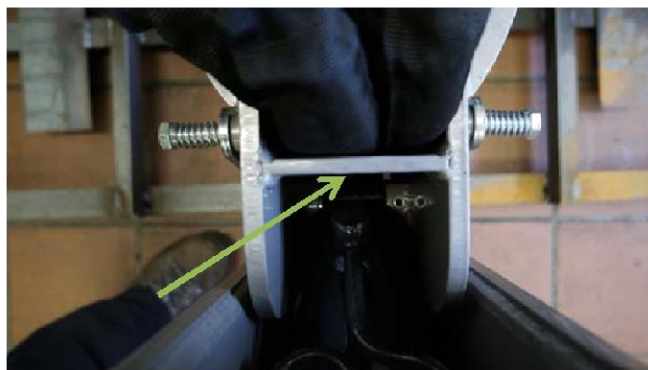

Fig.67 Excavator arm 10



Fig.64 Excavator arm 7



Fig.68 Excavator arm 11

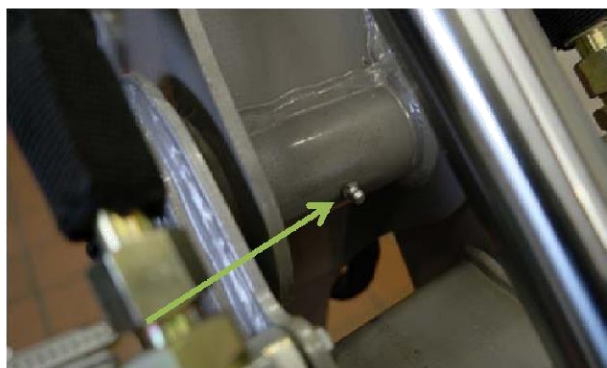

Fig.65 Excavator arm 8

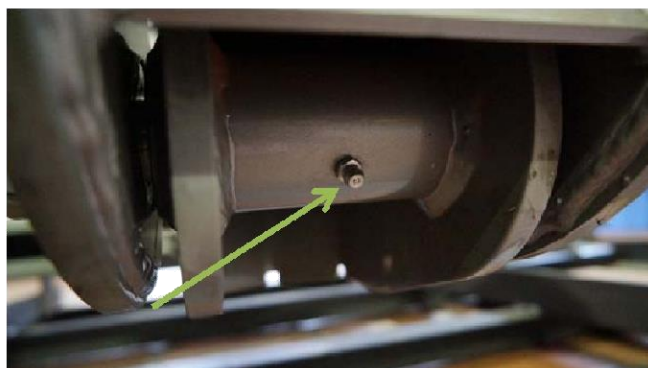

Fig.69 Excavator arm 12



Fig. 70 Cylinder from swivel joint 13



Fig. 74 Cylinder axel 17

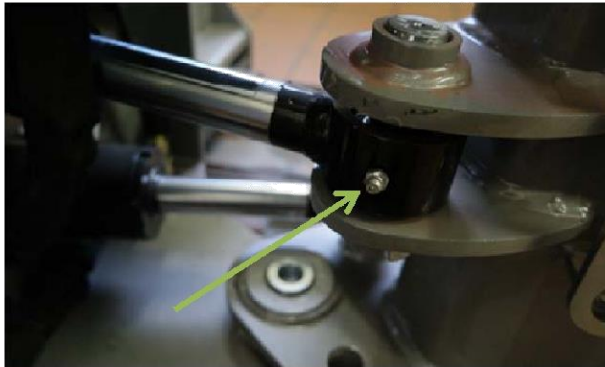

Fig. 71 Cylinder from swivel joint 14



Fig. 75 Cylinder axel 18

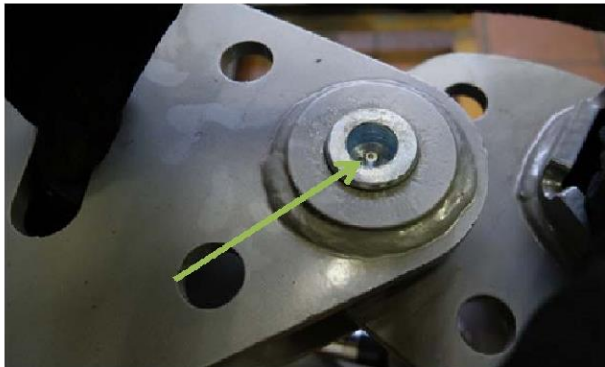

Fig. 72 Swivel joint 15



Fig. 76 Cylinder axel 19



Fig. 73 Swivel joint 16

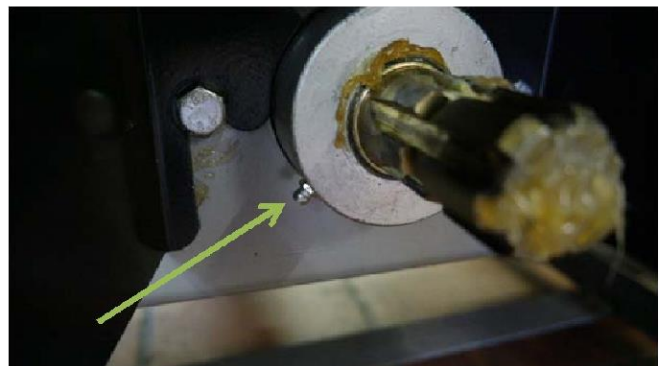

Fig. 77 Hydraulic pump shaft 20

---

16. Testing the hydraulic fluid and correcting the oil level

Before you use the digger, check all the hydraulic pipes for leaks and ease of movement. Be careful not to crush or damage the hydraulic pipes when operating the digger. Sit the rear digger horizontally straight to enable the oil level to be correctly filled up.

Run through all of the functions of all hydraulic components of the digger (drive it all the way in and all the way out). Do this three times for each function of the digger (scoops, excavator arms, lateral displacement, support) to completely fill the hydraulic circuit with fluid.

Then check the hydraulic fluid level of the hydraulic fluid tank and, if necessary, fill as described in step 2 of these assembly instructions.

---

# 5 Tractor Preparation

---



**Caution: Do not exceed the manufacturer's rating for maximum gross vehicle weight. Refer to Operator's Manual provided with tractor.**



**Caution: Certain Specific conditions may not permit safe use of backhoe at backhoe rating or may require more careful restricted operation at the rated load.**

## 5.1 Hydraulic System

Models BHM / BHSM Series

These Models are driven by the tractors Power Take Off, and are fitted with an in-built Hydraulic pump and tank. Check fluid level daily, ensure PTO shaft is greased and change hydraulic filter.



**Caution: The tractor / backhoe must only be operated with all safety equipment properly installed**

## 5.2 Tyre Inflation

Front Tyres must be maintained at the maximum recommended inflation to maintain normal tyre profile with the added weight of backhoe/material.

## 5.3 Wheel Tread Settings

Tractor front wheel tread setting must be restricted to wheel tread spacing recommended in the tractor Operator's Manual.

---

## 5.4 Attachment

Ensure your tractor's 3 point linkage system is fitted with sway chains before attaching the backhoe.

Failure to do so can cause the backhoe to swing when travelling potentially causing bodily injury or machine failure.

Inspect for any worn or damaged parts that are part of the connection between the tractor and backhoe. Replace if necessary with parts of suitable strength and quality.

## 5.5 Counter Weight

Add recommended ballast (either front weights or front end loader) in tractor's front-end for increased stability. Refer to tractor operator's manual for specific recommendations on counter weighting tractor.

**CAUTION: The tractor/backhoe should only be operated with all safety equipment properly installed. Keep assistants or bystanders a safe distance from the equipment operating area.**

---

## 6 Backhoe Operation

---



**CAUTION:** The tractor/backhoe should only be operated with all safety equipment properly installed. Keep assistants or bystanders a safe distance from the equipment operating area.

### 6.1 Precautionary Note

- Read and understand this manual to avoid accidents.
- Check the hydraulic fitting lines to be correct and set tightly.
- Maintain and repair (if it is needed) the parts or assemblies, check bolts and pins to be sure they are positioned tightly.
- Check tractor with the tractor operator's manual that it can prepared for operating.
- Warm up and operate the tractor and backhoe carefully. Purge any air in the hydraulic lines and cylinders by fully cycling all cylinders several times.
- Check hydraulic level in the tank to the specified level.
- Do not operate the hydraulics when not seated in the backhoe operator's seat
- Keep all assistants out of area of operation.
- Do not operate rapidly.
- Do not allow riders other than the operator to be on the tractor while operating.

### **Important**

Use tractor engine speed that your experience permits. At first set PTO RPM of the tractor to slow.

Do not use the boom, dipper arm, swing and stabilizers to lift, push or pull objects. Use only to maneuver and operate the bucket.

### **Important**

Practice quickly turning off the engine or stopping the backhoe immediately in case of an emergency situation.

---

## Important

Do not operate while the rear tractor wheels are off the ground by stabilizer. It is dangerous to operate the backhoe while rear wheels are off the ground.

Position vehicle so that the backhoe is as near as possible and in such a direction as to minimize the amount of backhoe turning required to dump.

Keep the unit clean and perform regular service.

We urge you to follow this advice:

1. Read and understand this manual as well as the Tractor Operator's Manual.
2. Remember and observe the safety Precautions brought to your attention in this manual, the tractor manual and on the machinery itself.
3. Use good common sense in the everyday operation of this unit. Safety recommendations can never be all-inclusive and you are responsible for watching out for and avoiding unsafe conditions.
4. Never exceed the limits of a piece of machinery. If its ability to do a job, or to do so safely, is in question, don't try it.
5. Don't hurry the learning process or take the unit for granted. Ease into it and become familiar with your new backhoe and tractor.



**Caution: When lowering a heavy load, ease it downward slowly. Never drop a loaded attachment and “catch it hydraulically”. Stopping a load after it has gained downward momentum places undue strain on the unit and may cause unnecessary damage to the backhoe or tractor or even worse, personal injury.**



**Caution: Before disconnecting hydraulic lines, relieve all hydraulic pressure. Escaping hydraulic oil under pressure can have sufficient force to penetrate the skin causing serious personal injury. If injured by escaping hydraulic oil, seek medical attention immediately.**



**Caution: Do not operate the backhoe if the fittings are leaking or if the hoses are damaged. A sudden line burst would cause the boom, or dipper arm bucket to drop suddenly, causing damage to the tractor or backhoe or injury to personnel.**

---

## 6.2 Initial Backhoe Operation

Before operating the backhoe, fully raise and lower the boom, arm, swing and hydraulic stabilizers two or three times. Then raise the bucket above the ground and cycle the bucket cylinders three times. Lower the bucket to the ground. Check the tractor hydraulic oil and the correct oil level.



**Caution: Before leaving the machine, stop the engine, remove the key. Place all controls in neutral, and either set the parking brake or place tractor in park as equipped.**

Always keep cylinders in a retracted position when the backhoe is not in use to guard against rust and contamination which may cause damage to the cylinder rods or hydraulic system. Also, lock the swing and boom while tractor is moving and storing for an extended period of time.

## 6.3 Cold Weather Operation

For smooth operation in cold weather, let the tractor warm up. Slowly cycle all of the cylinders several times to warm the oil in the hydraulic system. The backhoe may operate erratically until the hydraulic oil has warmed to operating temperatures.



**CAUTION: Operate controls only when seated in the operator's seat with seat belt on.**



## 6.4 Backhoe Hydraulic Controls

The backhoe hydraulic valve features 4 control levers. Refer to the diagram below for backhoe control functions. "Left" and "Right" are determined by the direction the operator is facing when seated in the backhoe.

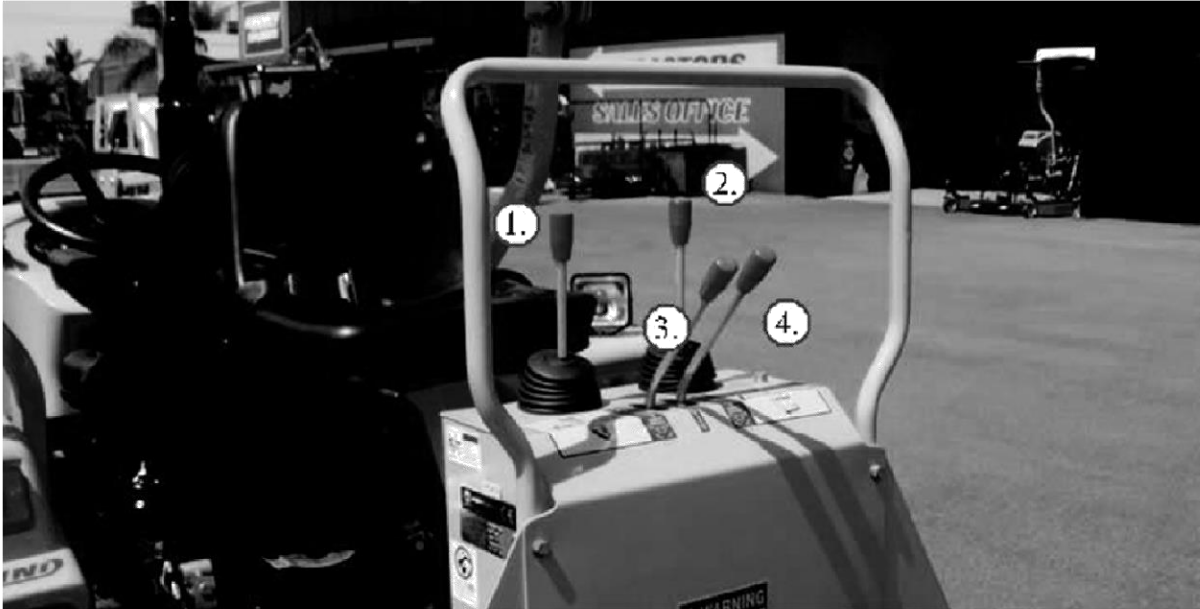

1. Dipper Arm / Bucket

2. Boom / Swing

3. Right Stabilize

Left Stabilizer

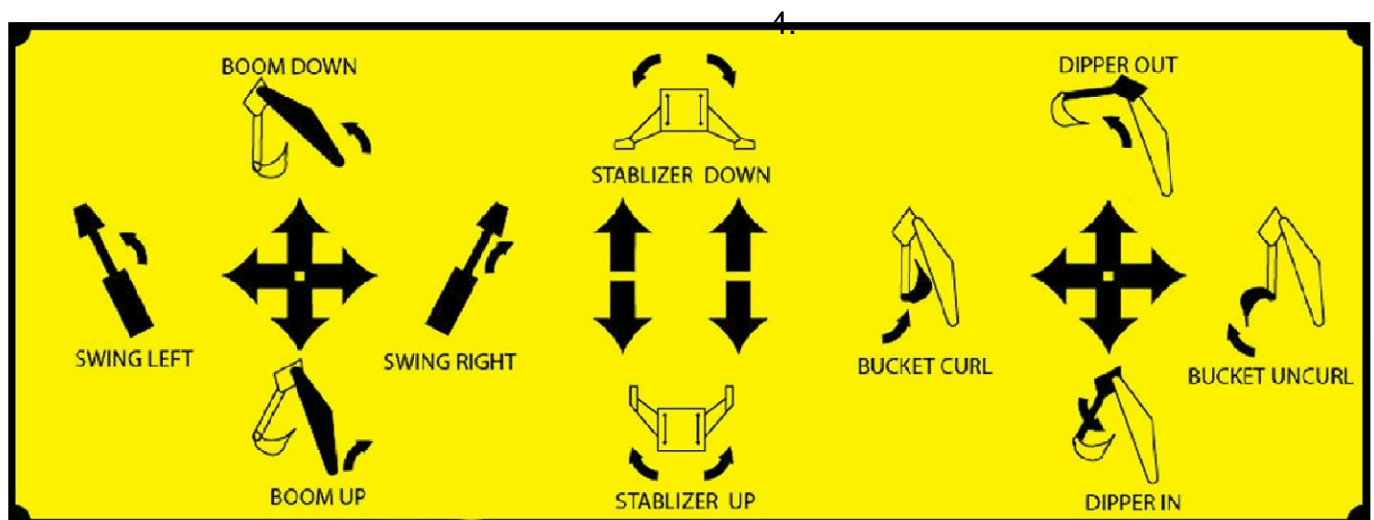

The two levers provide four simultaneous operations. Both experience and practice are needed to eliminate excess motion and increase operating efficiency.

Do not dig near the stabilizers to avoid possible accident

---

## 6.5 STABILIZER CLIPS

Stabilizer clips are to be used for transporting and dismounting backhoe. When locking or unlocking the clips move hydraulic very carefully in the right direction in order to prevent damage of clips.



## 6.6 Operating hydraulic Side shift

Prior to side shifting boom carrier, centralise and retract the boom, dipper arm and bucket.

Switch off the boom carrier lock for activating the hydraulic sideshift:



Now operate the lever for the hydraulic sideshift:

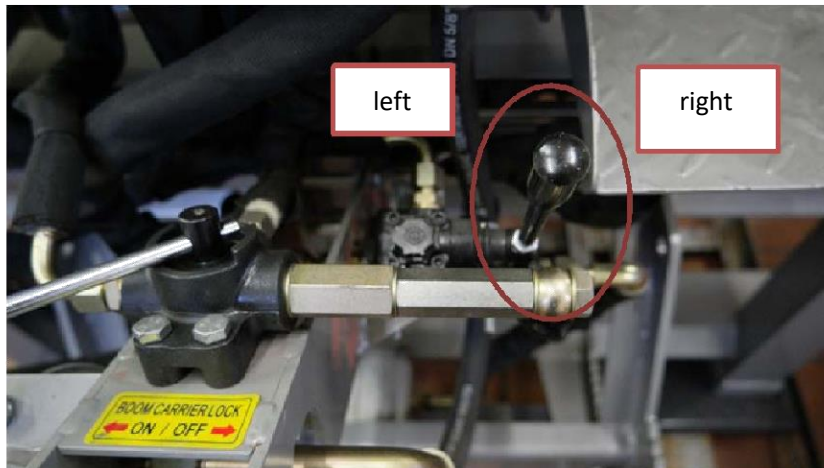

Switch on the boom carrier lock again when backhoe is in right position:



Observe the following safety warnings when working with your new backhoe / tractor.



**CAUTION:** Boom Carrier must be locked prior to operation.



**CAUTION:** When using a backhoe, be aware of bucket and boom location at all times. When raising A arm (Dipper) with bucket rolled forward, material can spill onto non target area causing injury to assistant or damage other objects.



**WARNING:** Do not side shift Boom Carrier unless the boom, dipper arm and bucket are centralised and retracted.



**WARNING: Do not dig near stabilizers. Ground under stabilizers could collapse.**

**Make all movements slow and gradual when practicing operation.**



**CAUTION: Operate from backhoe operators seat only. Pay attention, be ready to stop immediately in case of emergency.**



**CAUTION: To help prevent roll-over, adjust the rear wheels to their widest setting to maximize stability. Refer to your tractor Operator's Manual for recommendations.**

---

## 7 Maintenance

---

Item	Service	Service Interval
Hydraulic System Oil Level	Check	Daily / 10 Hours
Hydraulic System Oil / Filter	Replace	Every 50 Hours
Tyre Inflation	Check	Weekly / 50 Hours
Backhoe Pivot Points	Lubricate / Grease	Daily / 10 Hours
Backhoe Hydraulic Lines, Hoses, Connections	Check for leaks, wear	Daily / 10 Hours
Boom, Arm, Swing and Bucket cylinder rod packings	Check for seepage, service as needed	Daily / 10 Hours
Pivot Pin Bolts and Dust Covers	Check, replace if missing	Daily / 10 Hours
Pin Wear	Check, replace if necessary	Daily / 10 Hours
Backhoe Mount Hardware	Check visually	Daily / 10 Hours
Bolt and Nut Release	Re-torque	Every 25 Hours
Grease nipples	Lubricate	regularly



**CAUTION:** Do not perform service or maintenance operations with backhoe raised off the ground. For additional access to tractor and/or backhoe components remove backhoe.

---

## Important

Lower the backhoe to the ground and relieve pressure in backhoe hydraulic lines prior to performing any service or maintenance operations on the tractor or backhoe.



**CAUTION:** Escaping fluid under pressure can have sufficient force to penetrate the skin, causing serious injury, before disconnecting lines, be sure to relieve all pressure. Before applying pressure to the system, be sure all connections are tight and that lines, pipes and hoses are not damaged. Fluid escaping from a very small hole can be almost invisible. Use a piece of cardboard or wood rather than your hands to sear for suspected leaks. If injured by escaping fluid, seek medical attention immediately. Serious infection or reaction can develop if correct medical treatment is not administered immediately.

Refer to “lubrication and Maintenance Chart” for quick reference to Maintenance Operations.



**CAUTION:** Do not operate the backhoe if the fittings are leaking or if the hoses are damaged. A sudden line burst could cause the boom, dipper arm or bucket to drop suddenly, causing damage to the tractor or backhoe or injury to personnel.



**CAUTION:** Operate the backhoe from the operator seat only.



**CAUTION:** Do not stand or walk under a raised backhoe. Accidental movement of control lever or leak in hydraulic system could cause boom or dipper arm to drop, causing severe injury.



**CAUTION:** Operate from backhoe operators seat only. Pay attention, be ready to stop immediately in case of emergency.



**CAUTION:** To help prevent roll-over, adjust the rear wheels to their widest setting to maximize stability. Refer to your tractor Operator’s Manual for recommendations.

---

Note: when checking hydraulic system oil level, the backhoe should be on the ground and bucket fully retracted (all cylinders in retracted position).

Grease all backhoe pivot points daily (10Hours).

Inspect hydraulic hoses, connections, control valve and cylinders for evidence of leakage.

Tractor tyres should be maintained at maximum recommended inflation to maintain normal tyre profile with added weight of backhoe/material. Unequal rear tyre inflation can result in bucket not being level to the ground.

## 8 Trouble Shooting

This Trouble Shooting Chart is provided for reference to possible backhoe operational problems.

Determine the problem that best describes the operational problem being experience and eliminate the possible causes as listed by following the correction procedures

PROBLEM	Possible Cause	Correction
Swing, Boom, Dipper Arm	Low hydraulic fluid level	Check and replenish hydraulic fluid.
	Hydraulic hoses connected improperly	Check and correct hydraulic hose connections.
	Hydraulic hoses to / from control valve blocked	Check for damage (kinked) hoses, etc.
	Backhoe control valve or tractor main relief valve stuck open	Check system pressure, Repair or replace relief valve. Refer to the Tractor Operator's Manual.
	Low system pressure supplied from hydraulic pump	Check system pressure. Repair or replace pump.
	Control valve linkage broken	Inspect. Repair as required.
	Quick disconnect coupler(s) are not fully connected or "Flow Check"	Check coupler connections. Replace coupler(s) if necessary.
	Hydraulic Hose or tube line blockage	Check for evidence of damage to hoses or tube lines that



		would block flow of oil between cylinders and control valve.
	Cylinder piston assembly defective (not sealing)	Check cylinders for internal leakage as described in service section under cylinder leakage tests.
	Control Valve blockage	Inspect for blockage.
	Disassemble valve if necessary.	
	Safety lock pins (2) not removed	Remove and store safety pins.
	Stabilizer legs safety clip not released	Release the clips.
Cylinders operate in wrong direction relative to control valve lever position.	Hydraulic Hoses connected incorrectly.	Correct hydraulic hoses connections.
	Low hydraulic fluid level	Check and replenish hydraulic fluid.
	Cold hydraulic fluid	Allow hydraulic system to warm up to operating temperature
	Hydraulic oil viscosity too heavy or Incorrect oil	Check oil number and viscosity, refill correct hydraulic oil.



Slow or erratic move of cylinder	Engine R.P.M too slow  (hydraulic pump R.P.M too slow).	Increase engine speed to obtain satisfactory backhoe operation.
	Excessive weight in bucket.  Material weight exceeds maximum specified backhoe capacity.	Reduce material load. (Digging load)
	Control valve linkage binding / defective -	Check control valve linkage and repair if defective.
	Quick disconnect coupler restriction or coupler "Flow checks"	Check coupler connections.  Repair or replace.
	Hydraulic hose or tube line restriction hoses / Tube line)  Kinked or pinched	Check hoses and tubelines for evidence of restriction.
	Boom, Dipper arm or Bucket cylinder piston assembly leakage.	Check cylinders for leakage.  Repair as needed.
	Relief valve erratic or set below specifications	Check and reset relief valve.  Setting as needed.
	Control valve leaking internally. (bypassing fluid within valve).	Replace control valve and recheck operation.



<b>PROBLEM</b>	<b>Possible Cause</b>	<b>Correction</b>
Inadequate lifting capacity	Engine R.P.M too slow	Increase engine R.P.M
	Excessive load. Material loading exceeds specified backhoe capacity.	Reduce Load
	Relief valve setting below specifications	Check and reset relief valve setting as needed.
	Bucket, Boom and Dipper arm cylinder piston assembly leakage	Check Cylinders for leakage. Repair as needed.
	Control Valve leaking internally	Replace control valve and recheck operation.
	Hydraulic pump defective	Refer to "Hydraulic Pump Capacity Inadequate"
Aeration of Hydraulic Fluid	Low Hydraulic fluid level	Check and refill hydraulic system to proper level.
	Air lying into suction side of hydraulic pump	Check for loose or defective connections between reservoir and hydraulic pump.
	Cold Hydraulic Fluid	Allow hydraulic fluid to warm up to operating temperature.
	Hydraulic Oil viscosity too heavy or Incorrect Oil	Check Oil Number and Viscosity, refill correct hydraulic oil

System relieve valve squeals	Excessive load in bucket. Loading exceeds specified backhoe capacity	Reduce Load
	Relief Valve setting below specifications.	Check and reset valve setting as needed.
	Hydraulic hose, tube line	Check for evidence of restrictions in the hydraulic oil flow. Repair or replace defective components.
Backhoe Drops with valve spool in "centred" position  (no external oil leakage evident). Note: A gradual drop over an extended period of time is a normal condition.	Cylinder piston assembly leakage	Check cylinders for leakage
	Control valve internal leakage	Replace control valve and recheck
Control Valve spool(s) will not return to centered position	Control lever linkage binding	Determine origin of binding and repair
	Control valve spool centering is broken	Replace Centering Spring
	Control valve spool binding in valve body spool bore	Disassemble valve for inspection and repair.
	Loose Hydraulic connection	Tighten loose connections
	Defective hydraulic hose, tube line, adapter fitting or	Check for origin of oil leak and replace defective part.

External Hydraulic fluid Leakage	adapter fitting o-ring.	
	Control valve o-ring defective	Replace defective o-rings
	Control valve spool or body damaged or worn	Replace control valve
	Cylinder rod packing set leakage	Check cylinders for leakage. Repair as needed.
Hydraulic pump capacity inadequate	Cold Hydraulic fluid	Allow hydraulic fluid to warm up to operating temperature.
	Engine R.P.M too slow	Increase engine R.P.M
	Low hydraulic fluid supply	Refer to Tractor Operator's Manual for service recommendations.
	Hydraulic hose restriction	Check for evidence of restriction in hydraulic hoses.
	Hydraulic pump defective	Refer to Tractor Operator's Manual for recommended service procedures.
	Replace hydraulic pump if determined to be defective	
Cylinder Rod bend when cylinders extended	Excessive shock load on cylinders during transport	Replace defective parts. Review and observe proper and safe operational practices.



## 9 Parts Catalogue

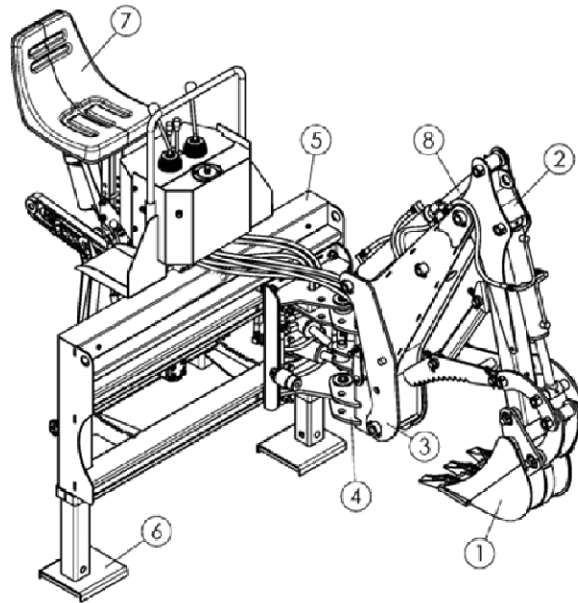

Item	ERP No.	Parts No.	Name	QTY
1	802910370	MBH-6.01.001A-30	bucket assembly	1
2-1	802910378	MBH-6.02.001	175 small arm assembly	1
2-2	802920400	MBH-7.02.001	195 small arm assembly	1
3-1	802910379	MBH-6.03.001	175 big arm assembly	1
3-2	802920401	MBH-7.03.001	195 big arm assembly	1
4-1	802910380	MBH-6.04.001	swivel	1
4-2	802920402	MBH-7.04.001	195 swivel	1
5	802910381	MBH-6.05.001T	base seat	1
6	802910382	MBH-6.06.001	support leg	2
7	802900137	MBH-5.07.001	seat	1
8-1	802910383	MBH-6.08.001T	175 hydraulic assembly	1
8-2	802920403	MBH-7.08.001T	195 hydraulic assembly	1

## 9.1 FRONT ARM

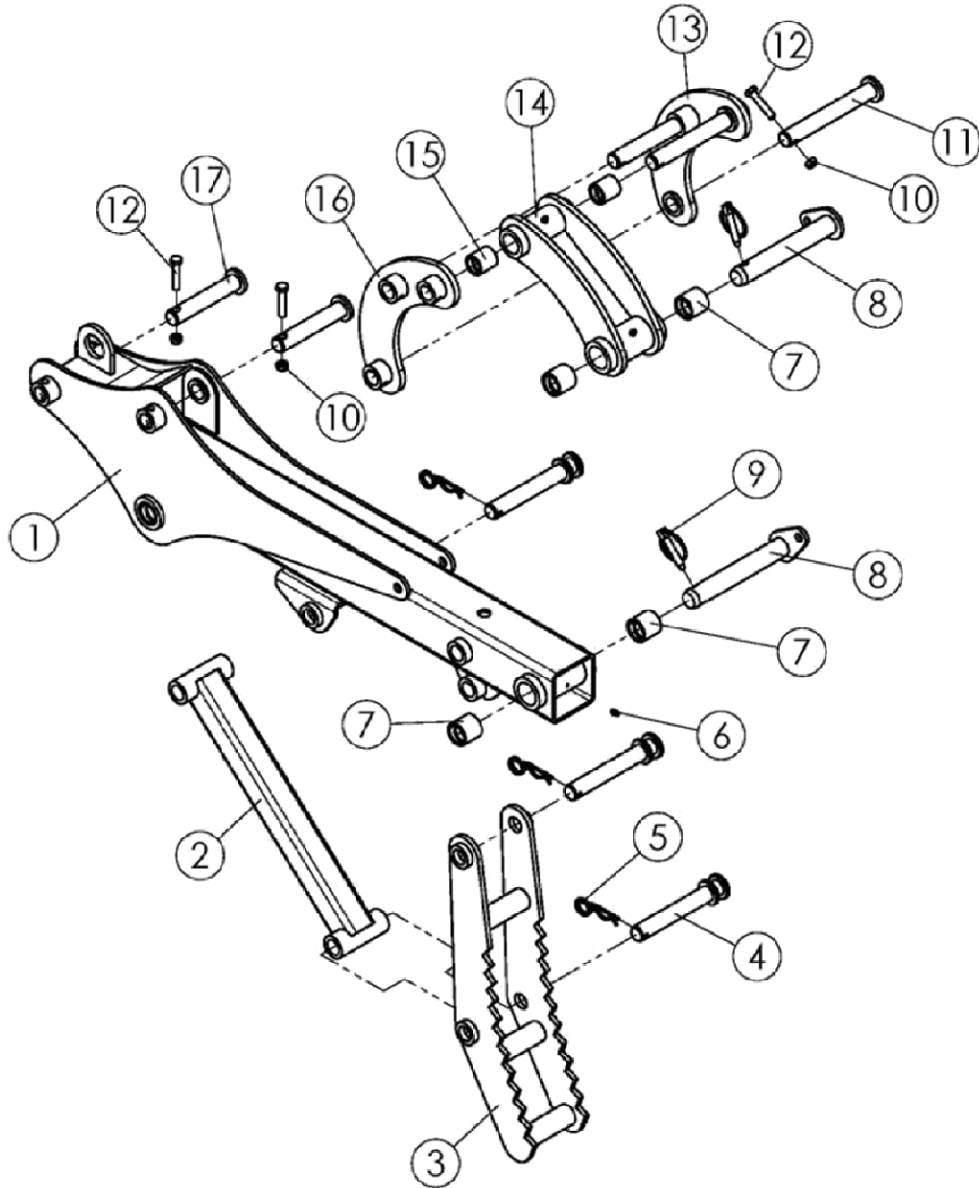

Item	ERP No.	Parts No.	Name	QTY
1-1	802910197	MBH-6.02.011A	small arm weldment	1
1-2	802920372	MBH-7.02.011A	Model-195 small arm weldment	1
2	802910227	MBH-6.02.023	support rod	1
3	802910224	MBH-6.02.022	thumb structure	1
4	702830118	ZL-FT254.202	lock pin	3
5	703340017	ZL-25.104	R pin	3
6	509010007	GB1152-M6	oil cup	5
7	702910195	MBH-6.02.101-1	bushing	6
8	802910218	MBH-6.02.015A	pin shaft assembly	2
9	700080010	200.56.011	lock pin assembly	2
10	503010762	DIN985-M10	nut	5
11	802910220	MBH-6.02.016	pin shaft	3
12	501010747	GB5782-M10X50	bolt	5
13	802910212	MBH-6.02.013	left swing arm weldment	1
14	802910214	MBH-6.02.014A	connecting bucket rod weldment	1
15	702910196	MBH-6.02.102-1	bushing	2
16	802910209	MBH-6.02.012	right swing arm weldment	1
17	802910222	MBH-6.02.017	pin shaft assembly	2



## 9.2 MAIN BOOM

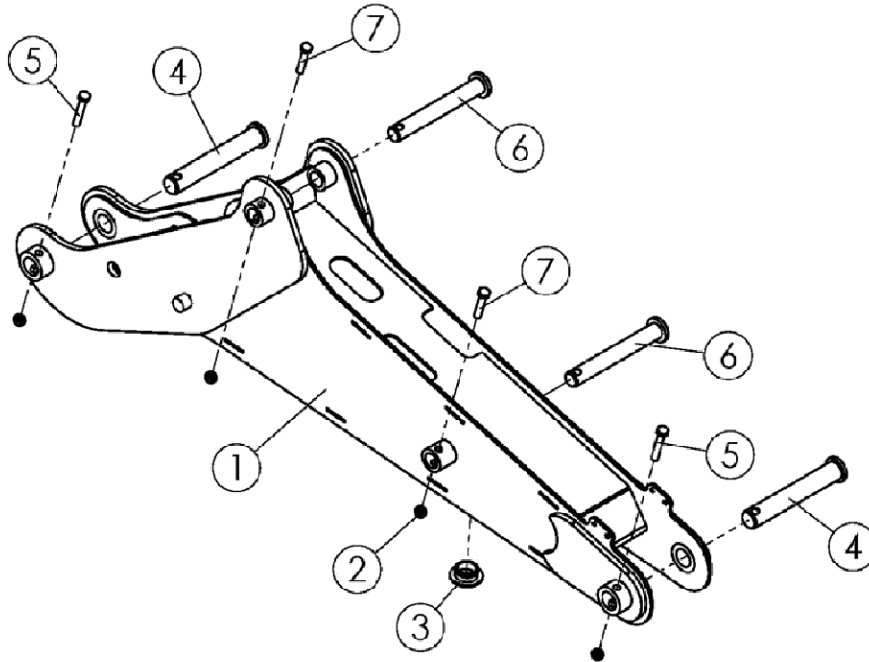

Item	ERP No.	Parts No.	Name	QTY
1-1	802910230	MBH-6.03.011-1	Model-175 big arm weldment	1
1-2	802920378	MBH-7.03.011-1	Model-195 195 big arm weldment	1
2	503010762	DIN985-M10	nut	4
3	702110077	FM120.00.110-2	rubber cover	1
4	802910241	MBH-6.03.012	pin shaft	2
5	501010749	GB5782-M10X60	bolt	2
6	802910220	MBH-6.02.016	pin shaft	2
7	501010747	GB5782-M10X50	bolt	2

### 9.3 SWING JOINT

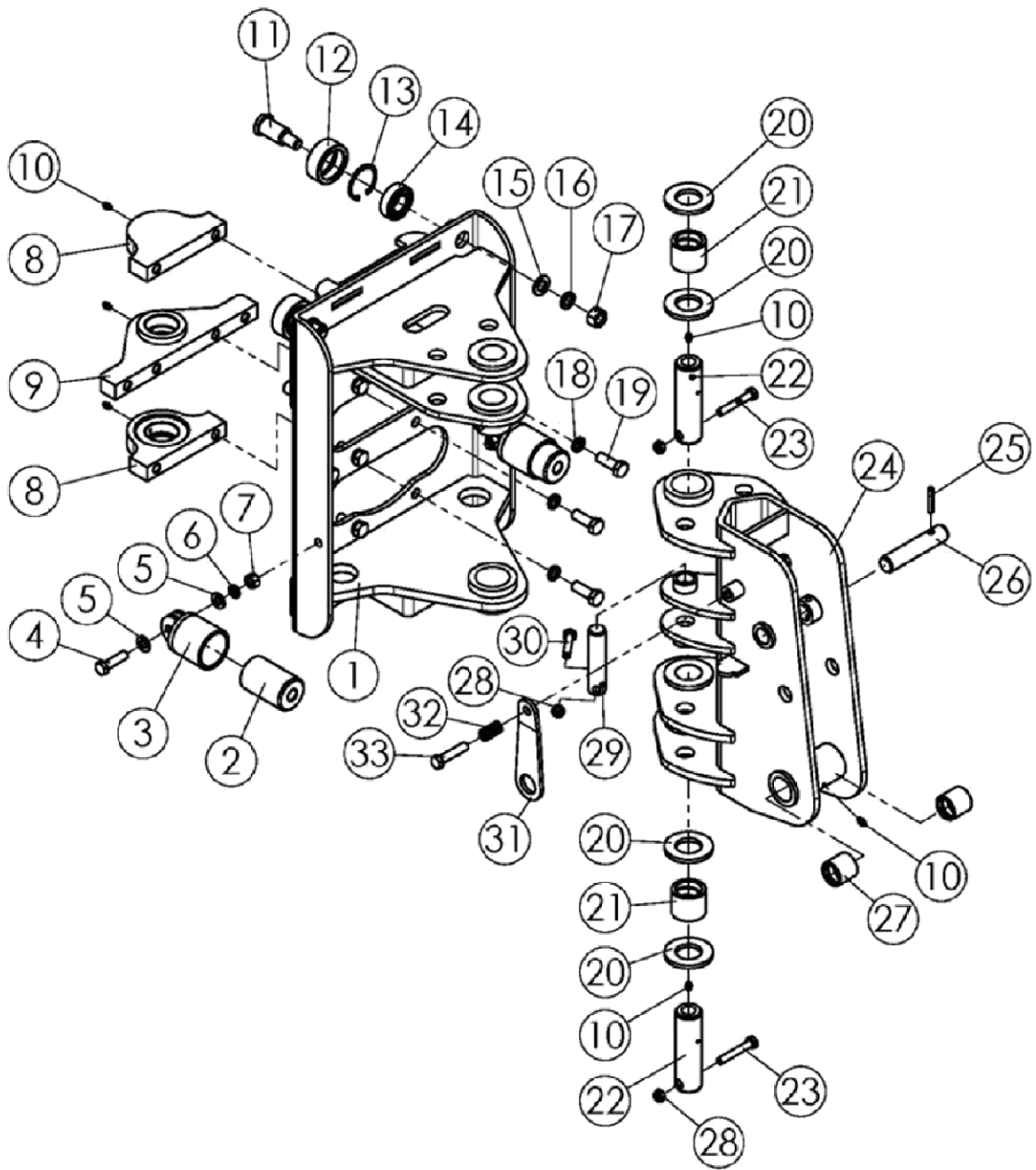

Item	ERP No.	Parts No.	Name	QTY
1	802910255	MBH-6.04.012-1	moving frame	1
2	702900051	MBH-5.04.104	pin shaft	2
3	802910264	MBH-6.04.014	bumper block seat	2
4	501010755	GB5782-M12X45	bolt	2
5	506010057	GB97.1-12	flat washer	4
6	506030037	GB93-12	spring washer	2
7	503010047	GB6170-M12	nut	2
8	702900053	MBH-5.04.108	turning cylinder seat	2
9	802900074	MBH-5.04.013	turning cylinder seat	1
10	509010007	GB1152-M6	oil cup	6
11	702910245	MBH-6.04.102	wheel axle	2
12	702910246	MBH-6.04.150	bearing ferrule	2
13	506060178	GB893.1-52	check ring	2
14	511021662	GB276-6205-2Z	deep groove ball bearing	2
15	506010059	GB97.1-16	flat washer	2
16	506030039	GB93-16	spring washer	2
17	503010049	GB6170-M16	nut	2

Item	ERP No.	Parts No.	Name	QTY
18	506030038	GB93-14	spring washer	8
19	501011142	GB5783-M14X40	bolt	8
20	702900052	MBH-5.04.105	cushion	4
21	702900055	MBH-5.04.119-1	bushing	2
22	702900050	MBH-5.04.103	knuckle shaft	2
23	501010750	GB5782-M10X65	bolt	2
24-1	802910247	MBH-6.04.011-1	Modeo-175 knuckle	1
24-2	802920387	MBH-7.04.011-1	Model-195 knuckle	1
25	508011566	GB879.1-8X40	elastic cylindrical pin	1
26	702910244	MBH-6.04.101	25X118 pin shaft	1
27	702910195	MBH-6.02.101-1	bushing	2
28	503010762	DIN985-M10	nut	4
29	702770068	AM60.03.104	bumper limited block	2
30	501010747	GB5782-M10X50	bolt	2
31	702930472	MBH-8.04.106	lock plate	2
32	702830014	BH-6.05.107	spring washer	2
33	501010759	GB5782-M12X65	bolt	2

## 9.4 MAIN FRAME

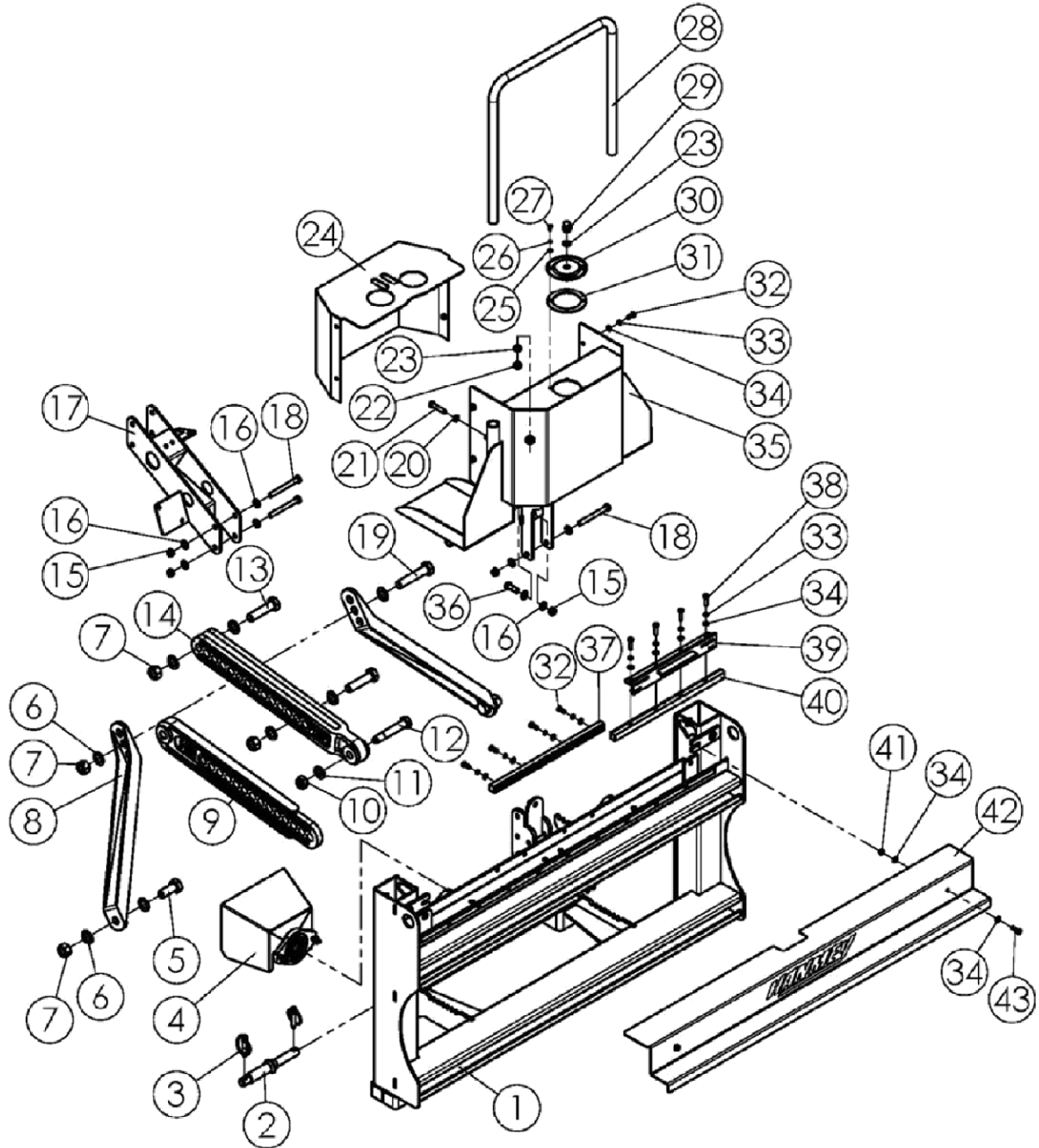

Item	ERP No.	Parts No.	Name	QTY
1	802910275	MBH-6.05.011-2	portal frame	1
2	702830020	BH-6.05.105	down pull rod connecting shaft	2
3	700080010	200.56.011	lock pin	4
4	802900135	MBH-6.05.019	IPT assembly	1
5	501011215	GB5783-M22X55	bolt	2
6	506010062	GB97.1-22	flat washer	10
7	503010052	GB6170-M22	nut	5
8	702830027	BH-6.05.216	inclined bracing	2
9	702930503	MBH-8.05.201-1	upper pull rod	1
10	503010767	DIN985-M20	nut	1
11	506010061	GB97.1-20	flat washer	2
12	501014282	GB27-M20X120	bolt	1
13	501010818	GB5782-M22X90	bolt	2
14	702930504	MBH-8.05.202	pull rod fork	1
15	503010763	DIN985-M12	nut	4
16	506010057	GB97.1-12	flat washer	8
17	802900096	MBH-5.05.016Y	frame weldment	1
18	501010764	GB5782-M12X110	bolt	3
19	501010820	GB5782-M22X110	bolt	1
20	503010099	GB6172.1-M10	nut	2
21	501011117	GB5783-M10X50	bolt	2
22	509010010	JB7941.2-M16X1.5	oil leveler	1
23	510015240	JB982-16	M16 washer	2

24	802910302	MBH-6.05.015T	rear hood	1
25	506010054	GB97.1-6	flat washer	4
26	506030034	GB93-6	spring washer	4
27	501011087	GB5783-M6X12	bolt	4
28	702910272	MBH-6.05.106	protection rod	1
29	703070084	CBW-00-011	M16X1.5 air plug	1
30	702930505	MBH-8.08.117	oil tank cap	1
31	702930506	MBH-8.08.118	sealing cushion	1
32	501011099	GB5783-M8X20	bolt	8
33	506030035	GB93-8	spring washer	12
34	506010055	GB97.1-8	flat washer	16
35	802910291	MBH-6.05.014T	control box weldment	1
36	501011127	GB5783-M12X35	bolt	1
37	702910273	MBH-6.05.126	rack	1
38	501011101	GB5783-M8X30	bolt	4
39	802910308	MBH-6.05.020	rack frame	1
40	702910274	MBH-6.05.127	rack	1
41	503010761	DIN985-M8	nut	2
42	702910271	MBH-6.05.102-2	hood	1
43	501011100	GB5783-M8X25	bolt	2

## 9.5 SUPPORTING LEG

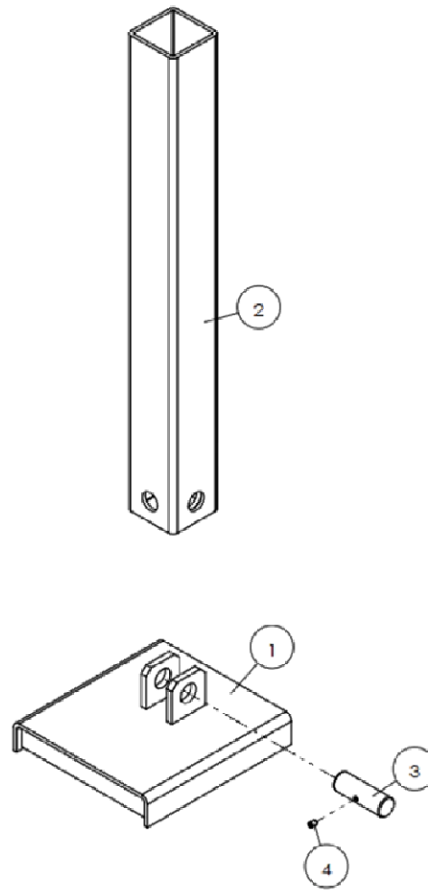

Item	ERP No.	Parts No.	Name	QTY
1	802910313	MBH-6.06.011	support leg	1
2	802910317	MBH-6.06.012	landing leg	1
3	702910324	MBH-6.08.104	pin shaft	1
4	505021124	GB78-M8x1x12	set screw	1



## 9.6 SEAT

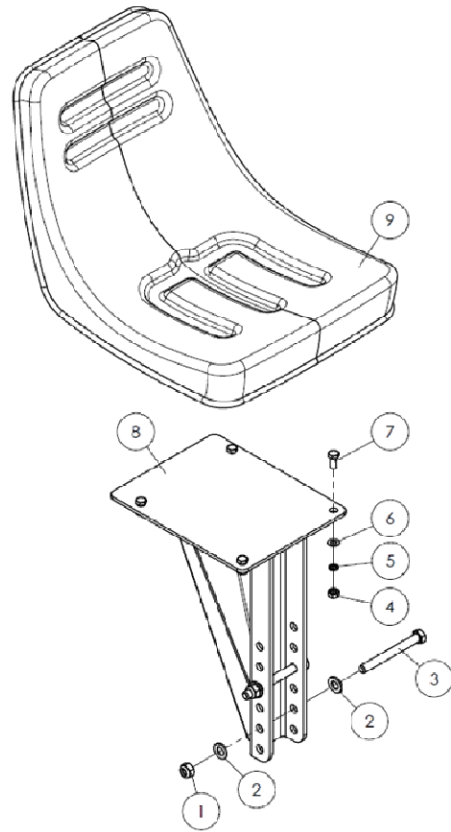

Item	ERP No.	Parts No.	Name	QTY
1	503010763	DIN985-M12	nut	2
2	506010057	GB97.1-12	flat washer	4
3	501010764	GB5782-M12X110	bolt	2
4	503010045	GB6170-M8	nut	4
5	506030035	GB93-8	spring washer	4
6	506010055	GB97.1-8	flat washer	4
7	501011099	GB5783-M8X20	bolt	4
8	802900118	MBH-5.07.011-1	seat frame	1
9	706040001	LW-7.06.101	seat	1

## 9.7 HYDRAULIC UNIT

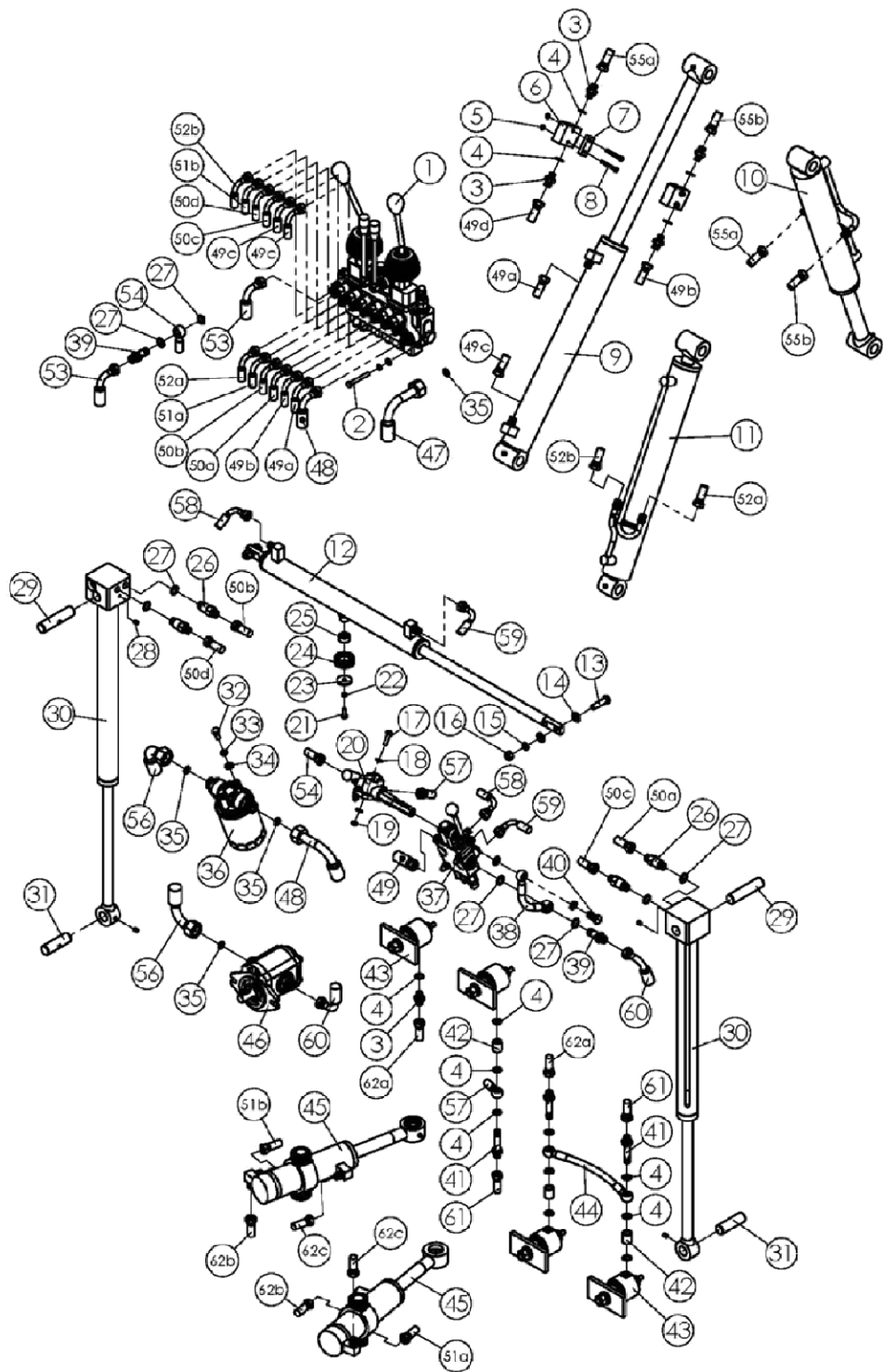

Item	ERP No.	Parts No.	Name	QTY
1	802900139	MBH-6.08.014T	multiple way valve	1
2	501010742	GB5782-M8X65	bolt	5
3	702930541	MBH-8.08.308Y	connector	5
4	510015239	JB982-14	14.7X22X1.5 washer	16
5	503010759	DIN985-M6	nut	4
6	702900139	MBH-5.08.133	transition block	2
7	702910100	MBH-6.08.132	cushion plate	2
8	501010733	GB5782-M6X50	bolt	4
9-1	702910328	MBH-6.08.012-1	175 cylinder	1
9-2	702920390	MBH-7.08.012-1	195 cylinder	1
10	702910327	MBH-6.08.011-1	cylinder	1
11-1	702910329	MBH-6.08.013-1	175 cylinder	1
11-2	702920391	MBH-7.08.013-1	195 cylinder	1
12	702910354	MBH-6.08.041-3	cylinder	1
13	501010755	GB5782-M12X45	bolt	2
14	506010057	GB97.1-12	flat washer	4
15	506030037	GB93-12	spring washer	2
16	503010047	GB6170-M12	nut	2
17	501011101	GB5783-M8X30	bolt	2
18	506010055	GB97.1-8	flat washer	12
19	503010761	DIN985-M8	nut	4
20	802900141	MBH-6.08.045	clamping control valve	1

21	501011099	GB5783-M8X20	bolt	2
22	506030035	GB93-8	spring washer	5
23	702910324	MBH-6.08.105	check ring	1
24	702900135	MBH-5.08.102-1	(22) gears	1
25	511010501	GB290-HK-2014	HK rolling bearing	1
26	702930538	MBH-8.08.301Y	connector	4
27	700050008	G3/8	17.28X23.80X2.03 washer	8
28	505021124	GB78-M8X1X12	set screw	4
29	702910322	MBH-6.08.101	pin shaft	2
30	702910339	MBH-6.08.019-1	cylinder	2
31	702910323	MBH-6.08.104	pin shaft	2
32	501011112	GB5783-M10X25	bolt	2
33	506030036	GB93-10	spring washer	2
34	506010056	GB97.1-10	flat washer	2
35	510013126	GB3452.1-G-14X2.65	O seal ring	4
36	802850146	MBH-6.08.018	oil filter	1
37	802900140	MBH-6.08.044Y	moving control valve	1
38	702900126	MBH-5.08.018Y	pipeline	1
39	702910326	MBH-6.08.303T	connector	2
40	501014707	GB3541-M14X1.5	bolt	1
41	702930540	MBH-8.08.307Y	connector	3
42	702930536	MBH-8.08.106	space bushing	3
43	702900132	MBH-5.08.040-1	cylinder	4
44	702910353	MBH-6.08.038	pipeline	1

45	702910344	MBH-6.08.023	cylinder	2
46	802830134	BH-6.08.022	oil pump	1
47	702910341	MBH-6.08.021	pipeline	1
48	702910342	MBH-6.08.022T	pipeline	1
49	702910348	MBH-6.08.029	pipeline	4
50	702910345	MBH-6.08.026	pipeline	4
51	702910346	MBH-6.08.027	pipeline	2
52	702910347	MBH-6.08.028	pipeline	2
53	702910337	MBH-6.08.016	pipeline	1
54	702900125	MBH-5.08.017	pipeline	1
55	702910349	MBH-6.08.030	pipeline	2
56	702910340	MBH-6.08.020	pipeline	1
57	702910350	MBH-6.08.036T	pipeline	1
58	702910356	MBH-6.08.043	pipeline	1
59	702910355	MBH-6.08.042	pipeline	1
60	702910336	MBH-6.08.015	pipeline	1
61	702910352	MBH-6.08.037	I pipeline	1
62	702930526	MBH-8.08.037	I pipeline	3

## 9.8 CONTROL VALVE

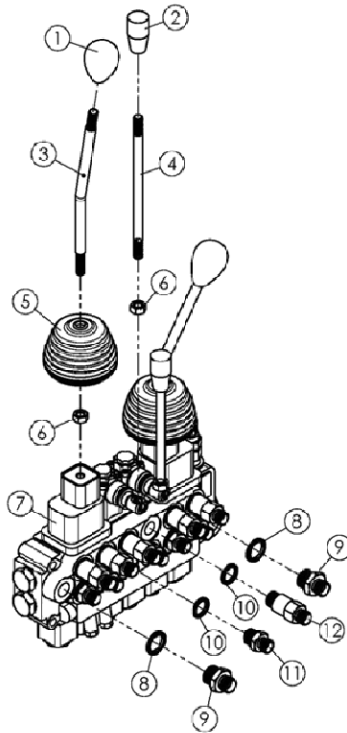

Item	ERP No.	Parts No.	Name	QTY
1	702830120	BH-6.07.090	handshank	2
2	702830121	BH-6.07.091	handshank	2
3	702900140	MBH-5.08.107	joystick	2
4	702910334	MBH-6.08.107	joystick	2
5	702830088	BH-6.08.105	rubber cover	2
6	503010046	GB6170-M10	nut	4
7	702820211	ZT6-F15-T/60-5	control valve	1
8	510015243	JB982-22	22.7X30X2.0 washer	2
9	702910333	MBH-6.08.304T	connector	2
10	510015241	JB982-18	18.7X26X1.5 washer	12
11	702910332	MBH-6.08.302T	connector	6
12	702910331	MBH-6.08.301T	connector	6

## 9.9 PTO CONNECTION

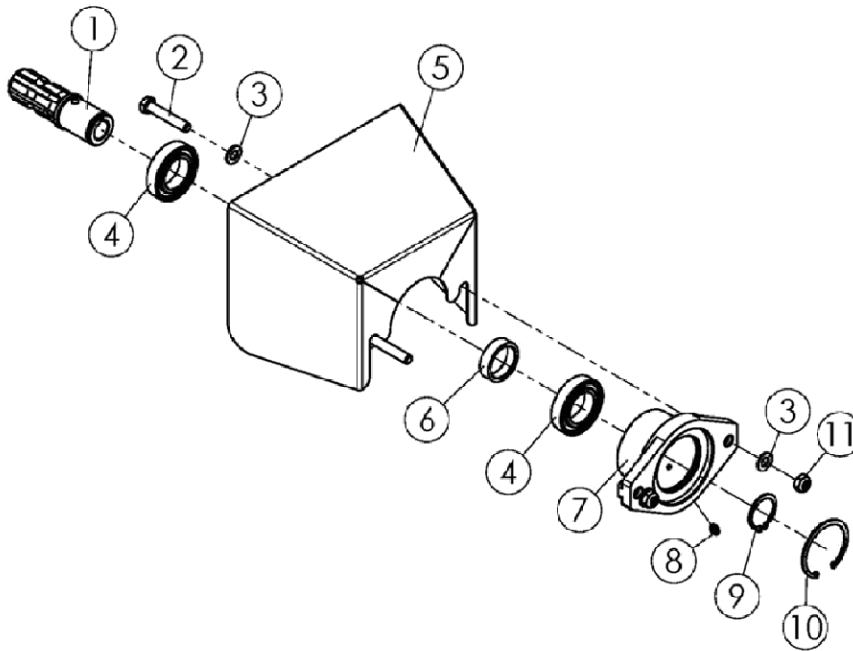

Item	ERP No.	Parts No.	Name	QTY
1	702830058	BH-6.05.143	power input shaft	1
2	501011118	GB5783-M10X55	bolt	2
3	506010056	GB97.1-10	flat washer	4
4	511022073	GB276-6007-Z	deep groove ball bearing	2
5	702910307	MBH-6.00.102	PTO protection cover	1
6	702830059	BH-6.05.144	space bushing	1
7	702830057	BH-6.05.142	bearing seat	1
8	509010007	GB1152-M6	oil cup	1
9	506060317	GB894.1-35	check ring	1
10	506060183	GB893.1-62	check ring	1
11	503010762	DIN985-M10	nut	2





---