

# Agilent Vac Elut 12 and 20 Position Manifold Instructions

## The Agilent 12- and 20-position extraction manifold features:

- 12- or 20-place positions for luer tip SPE cartridges
- Simple tip design allows for easy use of stopcocks or disposable needle tips
- Vacuum gauge with control and release valves for monitoring and adjustment of vacuum level
- A choice of four racks to accommodate a variety of collection vessels
- Three-point interlocking system to ensure proper orientation of racks, keying cartridge position to corresponding collection vessel
- Chemically resistant, non-contaminating construction of glass, polyethylene, polypropylene, and Delrin components
- Individually controlled, needle-tipped valves (stopcocks) permit flow control of each position

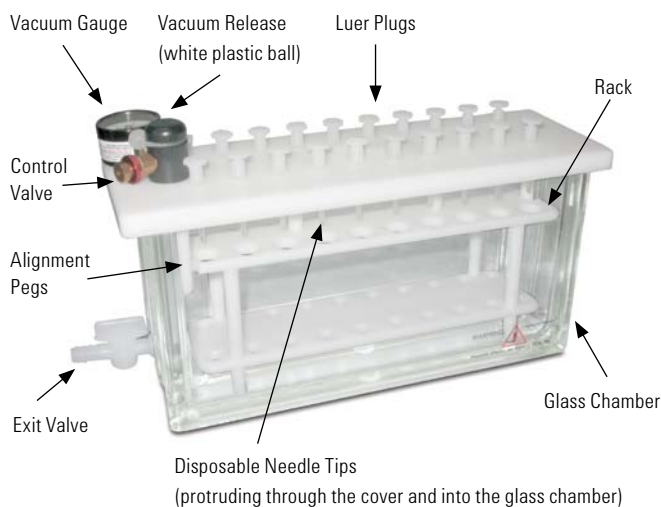

**Figure 1.** Vac Elut 20-position unit.

## Identifying Parts

Before assembling the extraction manifold, ensure that you have these parts, pictured in Figure 1.

- Glass chamber with exit valve installed
- White Delrin cover\* with polyethylene gasket, vacuum gauge, control and release valves installed
- Disposable needle tips, long (polypropylene)
- Stopcock valves
- Luer plugs, male
- Ejector tool
- Rack, 12- or 20- position, as specified

\*The three posts on the underside of the cover serve as elevated feet so the cover can be set down without damaging the needle tips. They also maintain specific alignment of sample cartridge and collection vessel.

## Using the Extraction Manifold

A typical solid phase extraction (SPE) procedure consists of the following steps:

1. Condition / equilibrate the SPE column bed.
2. Load the sample.
3. Wash off interferences.
4. Elute analyte(s) of interest.

The Agilent extraction manifold permits these steps to be carried out on up to twenty cartridges in parallel.

When sending all the eluents to waste, a rack is not necessary. This is usually the case for a typical SPE protocol when performing steps 1 through 3 above. In these cases waste is typically drawn into a liquid trap through the manifold's exit valve located at the base of the glass chamber. When optimizing or troubleshooting an SPE protocol, the waste from these steps can be collected in tubes located in the racks for individual analysis.



## Set up a vacuum system

1. Connect the outlet side of a liquid trap to a vacuum source using vacuum tubing.

**CAUTION:** Make certain that the liquid trap is compatible with, and has sufficient capacity to collect all the waste that will be generated in your SPE procedure. If the trap capacity is too small, waste may contaminate and /or damage the vacuum pump.

2. Connect the manifold's exit valve at the base of the glass chamber to the trap inlet using 3/8 in id vacuum tubing.
3. Put the cover top on the glass chamber. Do not install a rack at this time unless the needle tips and stopcocks required for your protocol are securely mounted in the top cover.

## Installing needle tips and stopcock valves

Install a stopcock with the valve handle pointing outward or a disposable needle tip in each of the top cover ports as detailed in this procedure and as shown in Figure 1. This makes the valve accessible for operation. The tips of the needles and stopcocks will extend into collection tubes mounted in a rack inside the manifold.

**CAUTION:** You must follow this procedure to obtain proper sealing of components mounted in the top cover. Failure to follow this procedure will cause joint leaks resulting in vacuum loss.

1. If installed, remove the rack from the manifold.
2. Place the top cover on the manifold and be sure it is properly seated on the edge of the glass chamber.

**CAUTION:** Damage to the top cover or rack may result if the rack is left in the manifold and the three alignment posts are resting on the rack when pressure is applied to the top cover. If the rack must be left in the manifold, verify the top cover is resting on the glass chamber and not on the rack before proceeding.

3. Insert a needle tip into a hexagonal hole and lightly wiggle the needle while pushing it down inside the hexagonal hole. Using your thumb, push the needle as far as it can go. Repeat this step for the rest of the needle tips. Use this same method to install stopcocks.
4. Place an ejector handle horizontally on top of two needles and press down hard on it. Repeat this procedure on all of the needles. Also use this procedure to seal the stopcock joint to the top cover.
5. For needle tips that are not in use, install a luer plug by pushing it down in the needle tip's inlet hole. The luer plug is used only with needle tips.  
**DO NOT INSTALL LUER PLUGS DIRECTLY ON THE COVER!**

## Removing items from the top cover

1. Remove all liquid from the columns.
2. To remove a luer plug or column, first twist it to break the friction joint. When the part turns freely, lift it out.

**CAUTION:** Do not pull a plug or column with a tight connection straight upward. This force can cause the joint between the top cover and the needle tip or stopcock to loosen, resulting in a loss of vacuum.

3. To remove a needle tip and/or stopcock valve, pry it out carefully with the ejector tool.

**CAUTION:** Push the ejector tool down slowly to prevent the launching of the needle tip.

Ball ring, unseat to break vacuum



**Figure 2.** Breaking the vacuum.

## Remove or install a rack of collection tubes

1. Close the exit valve or, alternatively, turn off the vacuum pump.
2. Break the vacuum in the manifold chamber by slightly offsetting the white ball from its seat (see Figure 2).
3. Remove the cover when the vacuum gauge reads atmospheric pressure.
4. Install or remove a rack of tubes.
5. Replace the top cover. If a rack is installed, carefully align the three posts on the bottom of the cover with the corresponding notches on the top plate of the rack.

## Manifold setup for protocol

1. Install the needle tips and stopcocks required by the protocol.
2. If required, remove or install a rack of tubes.
3. Put an extraction cartridge into each valve hub and seat it firmly.
4. Close all valves by turning the handles until each indicator shows that the valve is in the closed position.
5. Set up the vacuum system and turn on the vacuum pump. Adjust the check valve to set the desired vacuum level.
6. Follow the SPE protocol recommended for the type of column used and the application. Add fluid into the reservoirs before opening the stopcocks to start or resume flow.
7. Open each column's stopcock valve to evacuate the liquid as required by the protocol.

Lightly wiggle the needle tip while pushing it down in the hole. Press it with your thumb and then using the ejector handle push it hard against the hole to assure a good contact.

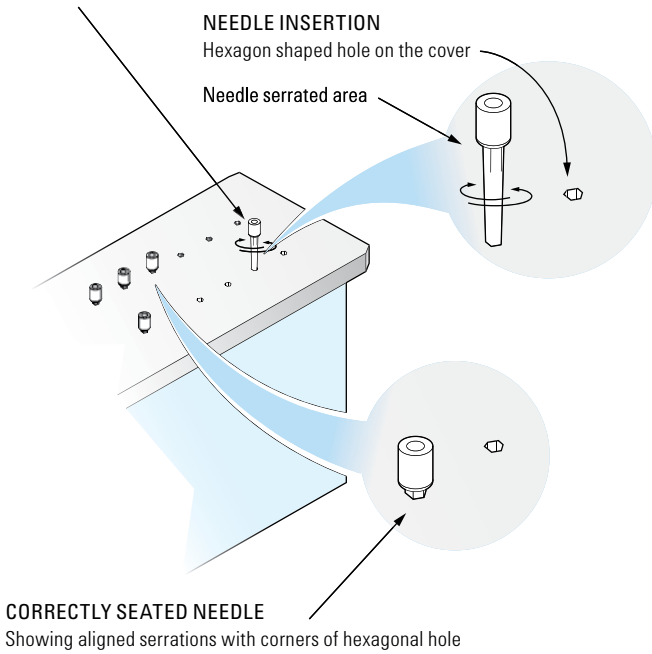

**Figure 3.**

Place ejector (handle portion) horizontally or diagonally across two needles and press down to assure proper vacuum seal.

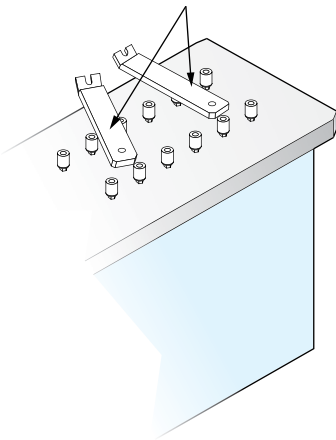

**Figure 4.**

**TO REMOVE LUER PLUG:**

Slowly twist the plug to break the contact, when it is loosened pull the plug away.

**TO INSTALL LUER PLUG:**

Push it in the needle tip hole(s).

**NOTE:**

Luer plug is only to be used on the needle tip, do not install plugs directly on the cover!

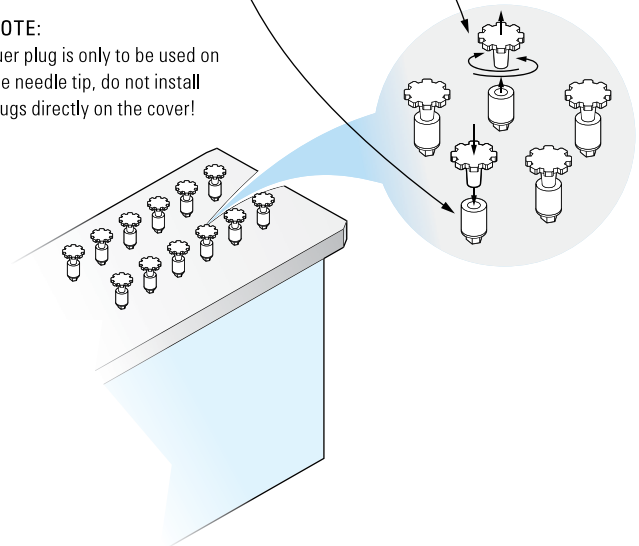

**WARNING:**

When removing plug(s), do not pull the plug straight upward, doing so can disengage the needle tip.

**Figure 5.**

**TO REMOVE CARTRIDGES:**

Empty cartridge! Twist cartridge to break off contact, and then pull upward. Pulling directly upward without twisting is not recommended and can cause the needle tip to disengage from the cover.

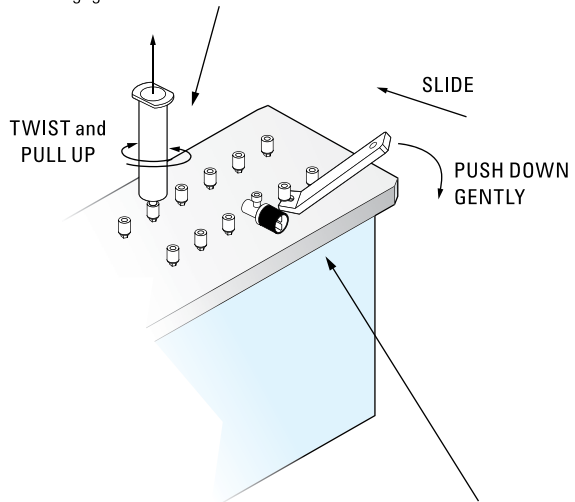

**TO REMOVE ANY OF THE NEEDLES / STOPCOCK VALVES (IF USED):**

Slide ejector under the needle tip or stopcock valve and push ejector down.

**CAUTION:**

Push down gently; pushing the ejector down too fast or too hard will cause the part to bounce off in the air.

**Figure 6.**

Note: Pictures shown are for illustration purposes only

## Ordering Information

Description	Part No.
<b>Standard Vac Elut 20 Manifold</b>	
Vac Elut manifold with collection rack for 10 x 75 mm test tubes	12234105
Vac Elut manifold with collection rack for 13 x 75 mm test tubes	12234100
Vac Elut manifold with collection rack for 13 x 100 mm test tubes	12234101
Vac Elut manifold with collection rack for 16 x 75 mm test tubes	12234102
Vac Elut manifold with collection rack for 16 x 100 mm test tubes	12234103
<b>Racks and replacement parts for Standard Vac Elut 20 Manifold</b>	
Standard glass basin	12234505
20-port collection rack for 13 x 75 mm test tubes	12234507
20-port collection rack for 13 x 100 mm test tubes	12234508
20-port collection rack for 16 x 75 mm test tubes	12234509
20-port collection rack for 16 x 100 mm test tubes	12234510
Replacement lid gasket	12234502
Vac Elut 20 lid cover	12234501
<b>Tall Vac Elut 20 Manifold</b>	
Vac Elut 20 manifold with tall glass basin and collection rack for 16 x 150 mm test tubes, complete system	12234104
20-port Collection rack for 10 x 75 mm test tubes	12234517
Tall glass basin	12234512

Description	Part No.
<b>Vac Elut 12 Manifold</b>	
12-port vacuum manifold processing station and collection rack for 16 x 100 mm test tubes	5982-9110
<b>Racks and replacement parts for Vac Elut 12 Manifolds</b>	
Vac Elut 12 lid cover	5982-9111
Vac Elut 12 sealing gasket	5982-9112
Vac Elut 12 glass chamber	5982-9113
12-port collection rack for 13 x 75 mm test tubes	5982-9114
12-port collection rack for 13 x 100 mm test tubes	5982-9115
12-port collection rack for 16 x 75 mm test tubes	5982-9116
12-port collection rack for 16 x 100 mm test tubes	5982-9117

Description	Unit	Part No.
<b>Common parts and disposables for all Manifolds</b>		
Manifold needle tip ejector tool		5982-9105
Polypropylene delivery needles	25/pk	12234511
Manifold SS needle with polypropylene coating	25/pk	12234042
Stainless steel needle tip	25/pk	12234038
Replacement exit valve for glass basin		12234506
Manifold exit valve replacement kit		12234005
Vacuum gauge assembly		12234504
Manifold ball ring/vacuum quick release		12234013
Manifold short valve stopcock	15/pk	12131005
Manifold long valve stopcock	20/pk	12234520
Manifold male luer plugs	25/pk	12234518

**A portfolio of solutions designed to give you ultimate confidence in your results.**

Agilent sample preparation products improve the quality of your samples, so you improve the quality of your analysis. From solid phase extraction... to industry leading instruments... to quality columns, Agilent has all the solutions to give you greater confidence in your results.

**Learn more**

[www.agilent.com/chem/sampleprep](http://www.agilent.com/chem/sampleprep)

**Buy online**

[www.agilent.com/chem/store](http://www.agilent.com/chem/store)

**Find an Agilent office or authorized distributor**

[www.agilent.com/chem/contactus](http://www.agilent.com/chem/contactus)

**U.S. and Canada**

1-800-227-9770, [agilent\\_inquiries@agilent.com](mailto:agilent_inquiries@agilent.com)

**Europe**

[info\\_agilent@agilent.com](mailto:info_agilent@agilent.com)

**Asia Pacific**

[inquiry\\_lsca@agilent.com](mailto:inquiry_lsca@agilent.com)

**India**

[india-lsca\\_marketing@agilent.com](mailto:india-lsca_marketing@agilent.com)

Agilent shall not be liable for errors contained herein or for incidental or consequential damages in connection with the furnishing, performance, or use of this material.

Information, descriptions, and specifications in this publication are subject to change without notice.

© Agilent Technologies, Inc., 2012  
Published in the USA, January 24, 2012  
Edition Code 04100-06/11  
Part Number 7704100



**Agilent Technologies**