

Parametrii Tehnici

- Tip caroserie hatchback
- Tip motor turbo
- Injectie Injectie indirecta multipunct
- Cilindree (cm³) 999
- Numar cilindri / supape 3/12
- Carburant Benzina fara plumb
- Norma de poluare EURO 6
- Transmisie 4X2
- Putere maxima kw CEE (CP)/ regim (tr/min) 67 (90) / 4600-5000
- Cuplu maxim Nm CEE/ regim (tr/min) 160 / 2100-3750
- Stop & Start / Energy Smart Management
- Tip cutie de viteza manuala
- Numar de rapoarte 6
- Viteza maxima (km/h) 172
- PNEURI Dimensiuni omologate 205/60 R16
- Emisii CO₂ in ciclu mixt (g/km) WLTP 119 / 128
- Consum in ciclu Urban (l/100km) WLTP 6,1
- Consum in ciclu extra-urban (l/100km) WLTP 4,4
- Consum in ciclu mixt (l/100km) WLTP 5
- Tip omologare WLTP
- Capacitate utila rezervor (litri) 50
- Functie/Mod ECO
- Tip sistem directie asistata electric
- ABS + EBD (repartitie electronica forta de franare) + AFU (asistenta la franarea de urgenta)
- ESP (sistem de stabilitate electronica) + HSA (Hill Start Assist)
- Masa proprie vehicul maxima (la gol) 1136 kg
- Masa total maxim autorizata (MTMA) 1578 kg
- Sarcina utila (min-max) - cu sofer 75 kg 442/482
- Volum portbagaj (dm³, conform norma ISO 3832) 328 l
- Ampatament 2604 (mm)
- Lungime 4099(mm)
- Garda la sol (la gol) 201(mm)
- Inaltime cu bare de acoperis longitudinale 1587(mm)
- Latime vehicul fara/cu oglinzi laterale 1848 / 2007 (mm)

Dimensions (mm)

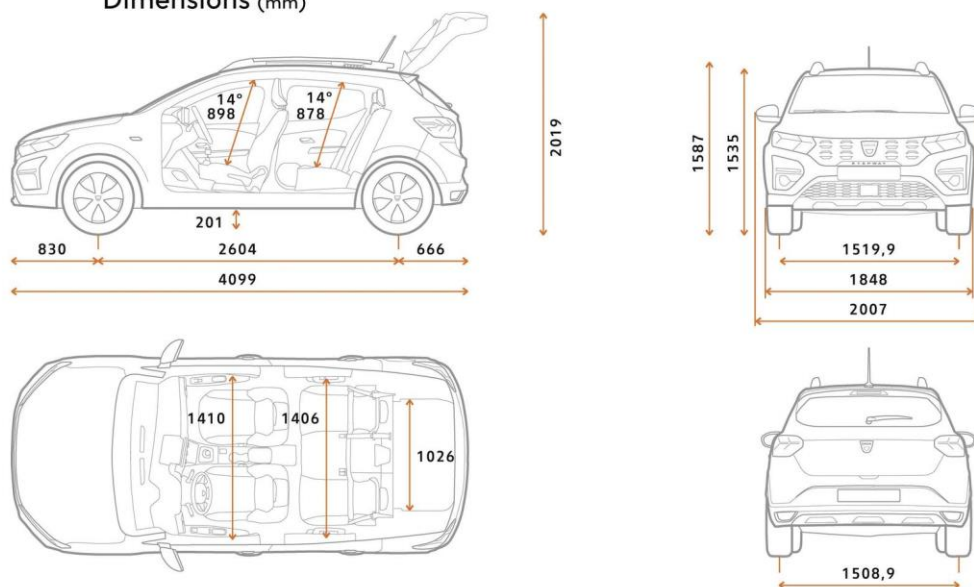

Poze sunt cu titlu de prezentare



