

# BUTTERFLY VALVE DOUBLE ECCENTRIC FLANGED FAF 3800



## Features

- Double Eccentric structure ensures low operating torques with zero leakage performance.
- Inner and outer surfaces of the valve are coated with average 250 microns thickness of fusion bonded epoxy. (FBE) min 300micron available upon request.
- Higher thicknesses are available upon request.
- Low moments are obtained by decreasing the friction through self-lubricating bushings.
- Can bear high stretching stresses on the pipeline through the ductile iron body and disc
- High impact resistance
- Reduces the pressure loss through the disc designed in accordance with the direction of flow
- Pressure loss is at minimum level by double shaft design
- Sealing gaskets made of EPDM (default), NBR or VITON supplied according to operating conditions and demand can be disassembled and replaced easily in field conditions
- With the o-rings on the bearing bushings, disc pin holes are protected against corrosion (Dry shaft)
- Retaining ring is assembled to the disc with imbus bolts, the disc is protected against corrosion by placing o-rings under the bolts.
- Through the gearbox assembled on top flange, it maintains opening/closing the valve with very low torques.
- Lifting lugs and feet ease the weight balance during transport and installation.
- With the stainless steel welding, in the valve will have higher sealing resistance.

## Temperature

- +130 °C EPDM
- +100 °C NBR
- +180 °C VITON

## PRODUCTION STANDARDS

DN100 → DN2000  
PN 10-16-25

Design	EN 593
Connection	EN 1092-2 ISO 7005-2 - Flanged
End Connection	EN 558 Series 14 DIN 3202 F4
Marking	EN 19
Tests	EN 12266-1
Corrosion Protection	Electrostatic Powder Epoxy WRAS Approved (Optional)

## Product Description

FAF3800 Double Eccentric Flanged Butterfly Valve; operating through the disc rotating with a quarter turn (90 degrees), ensures 100% sealing with the sealing "T" section ring fixed to the outer diameter of the disc fully facing the seat surface inside the body perimeter made of stainless steel welding. The WRAS approved epoxy coating is suitable for potable water systems.

## Versions

- Standard version with gearbox (IP67-optional) and handwheel
- Gearbox ready to install actuator
- With electrical actuator
- Custom production for specific orders

## Accessories

- Handwheel
- T-key + FAF7250
- Extension spindle, ST steel + FAF3790
- Surface box, cast iron + FAF3790K
- Flange adaptors + FAF3960
- Position indicator
- Dismantling joint + FAF3900
- Limit switch

## Scope of Application

- Chamber installation
- Installation in plants
- Pipelines
- Water treatment plants
- Pumping stations
- Tanks and reservoirs
- Seawater applications
- Power plants (cooling water pipelines)
- Industry

# BUTTERFLY VALVE DOUBLE ECCENTRIC FLANGED FAF 3800

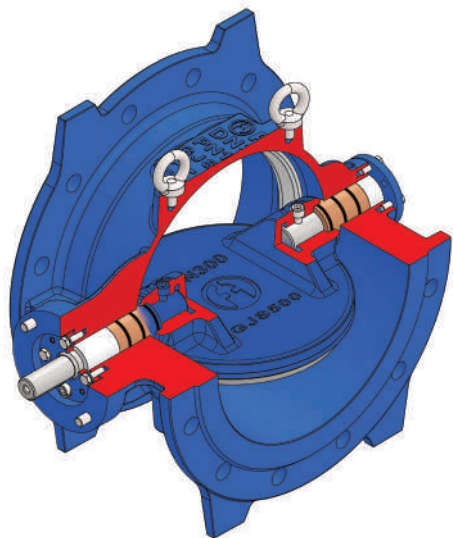

### MATERIAL SELECTION

Body	EN-GJS-500 Ductile Iron / GGG50
Disc	EN-GJS-500 Ductile Iron / GGG50
Stem	1.4021 - AISI 420 Stainless Steel (Default) 1.4301 - AISI 304 Stainless Steel (Optional) 1.4401 - AISI 316 Stainless Steel (Optional)
Sealing	EPDM ( NBR, VITON Optional )
Gearbox	EN GJL 250 - Enclosure Class - IP67
Retaining Ring	ST.37 Steel (Default) 1.4301 - AISI 304 Stainless Steel (Optional) 1.4401 - AISI 316 Stainless Steel (Optional)

### Standards

Criteria	Old Standards	New Standards
Design	EN 11341, DIN 3354, BS 5155	EN 593
End Connection	DIN 3202, BS 5155	EN 558-1 Series 14
Flange	DIN 2501, BS 4504	ISO 7005, EN 1092
Test	DIN 3230	EN 12266, EN 1074
Casting	GGG 40 - GGG 50	EN GJS 400-15, EN GJS 500-7
Stainless Steel	X20Cr13, AISI 420-AISI 304-AISI 316	1.4021-1.4301-1.4401

### General Information About Double Eccentric Flanged Butterfly Valves

- Valve sealing rate: EN 12266-1 / 2. Leakage is not allowed.
- Valve is designed to be leakproof and with anti blow out shaft system when driving component (lever, gear box, actuator) are removed.
- High flow rates are critical for Double Eccentric Flanged Butterfly Valves. Thus the flow rate of the network must conform to the following table.

PS BAR	Highest Flow Rate (m/s)	
	Liquid Fluid	Gas Fluid
up to 6	2,5	25
6<PS≤10	3	30
10<PS≤16	4	35
PS>16	5	40

### PRODUCTS MODEL CODES

FAF3800	BUTTERFLY VALVE - PN16
FAF3810	BUTTERFLY VALVE - PN10
FAF3825	BUTTERFLY VALVE - PN25

### Note

- For proper use and safety precautions please follow the installation and operating instructions.

### VALVE TEST PRESSURE (Bar)

MAX. OPERATING PRESSURE	BODY / SHELL TEST	SEAT TEST
10	15	11
16	24	17,6
25	37,5	27,5
40	60	44

100% of the valves are subjected to hydrostatic tests at FAF facilities.

# BUTTERFLY VALVE DOUBLE ECCENTRIC FLANGED FAF 3800



## Material List

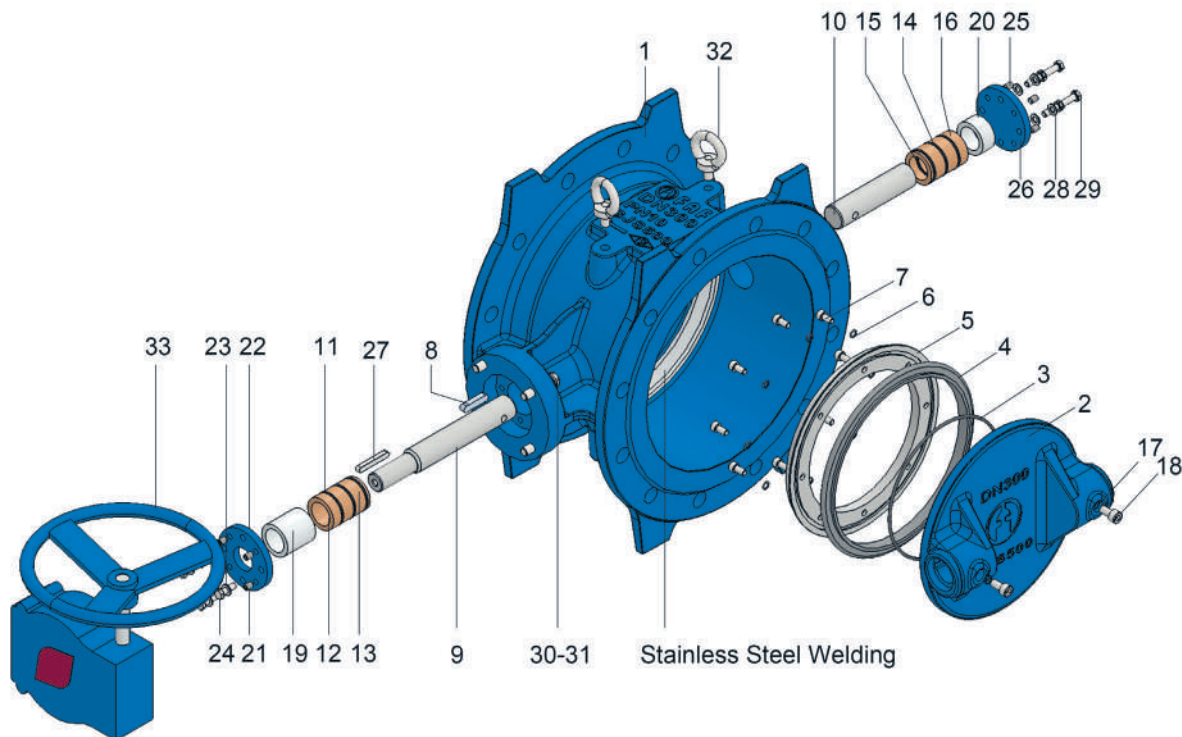

NO	ITEM	MATERIALS
1	BODY	EN GJS 500
2	DISC	EN GJS 500
3	O-RING	NBR / EPDM
4	SEALING RING	EPDM / NBR /VITON
5	RETAINING RING	STEEL ST 37
6	O RING	NBR / EPDM
7	IMBUS BOLT	STAINLESS STEEL A2
8	KEY	STEEL 1.0254
9	MAIN SHAFT	STAINLESS STEEL 1.4021
10	SUPPORT SHAFT	STAINLESS STEEL 1.4021
11	O-RING	NBR / EPDM
12	O-RING	NBR / EPDM
13	BUSHING	BRONZE
14	O-RING	NBR / EPDM
15	O-RING	NBR / EPDM
16	SUPPORT SHAFT BUSHING	BRONZE

NO	ITEM	MATERIALS
17	O RING	NBR / EPDM
18	IMBUS BOLT	STAINLESS STEEL A2
19	MAIN SHAFT BEARING	DELTRIN
20	SUPPORT SHAFT BEARING	DELTRIN
21	SETSCREW	STAINLESS STEEL A2
22	TOP COVER	STEEL 1.0254
23	WASHER	STAINLESS STEEL A2
24	HEXAGON BOLTS	STAINLESS STEEL A2
25	SETSCREW	STAINLESS STEEL A2
26	BOTTOM COVER	STEEL 1.0254
27	KEY	STEEL 1.0254
28	WASHER	STAINLESS STEEL
29	HEXAGON BOLTS	STAINLESS STEEL A2
30	WASHER	STAINLESS STEEL
31	HEXAGON BOLTS	STAINLESS STEEL A2
32	LIFTING LUGS	GALVANIZED STEEL
33	GEAR BOX	EN GJL 250 - ENCLOSURE CLASS (IP68 OPTIONAL)

# BUTTERFLY VALVE DOUBLE ECCENTRIC FLANGED FAF 3800



## Technical Details & Drawing, Dimensions

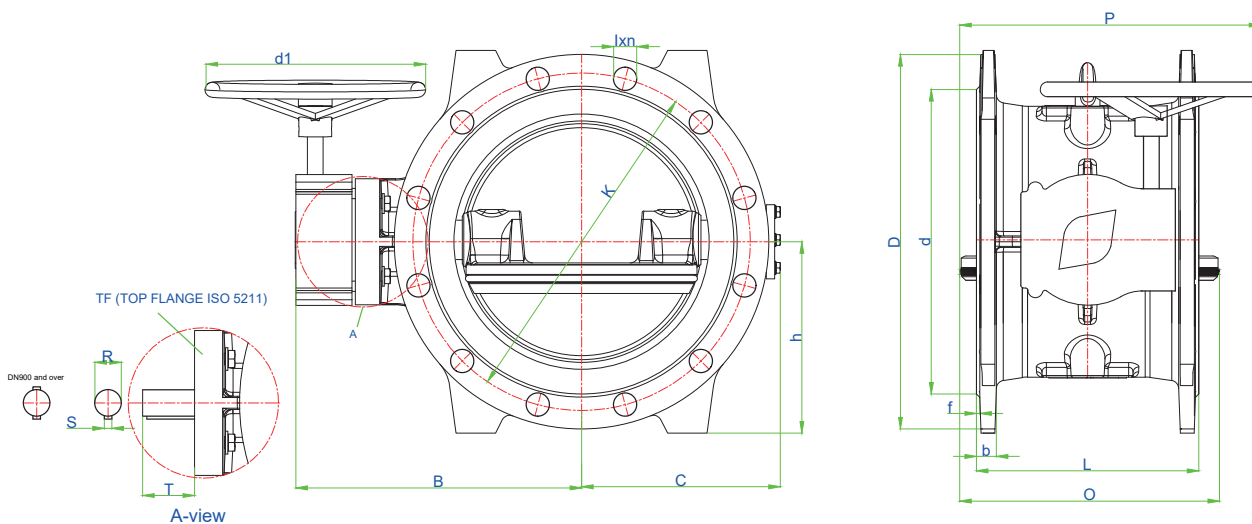

DIMENSIONS - PN16																	RATINGS			
DN (mm)	D	K	d	Ølxn	f	b	L	O	B	C	h	d1	P	R	S	T	TOP FL	VALVE TORQUE * (Nm)	Kv m <sup>3</sup> / h	Weight (kg)
100	220	180	156	19x8	3	19	190	101	183	119	110	100	141	21,7	8	45	F10	90	600	19
150	285	240	211	23x8	3	19	210	148	225	150	145	100	227	21,7	8	45	F10	240	1400	29
200	340	295	266	23x12	4	20	230	200	275	189	172	250	278	21,7	8	45	F10	260	2500	46
250	405	355	319	28x12	4	22	250	248	297	220	205	350	366	27,8	8	55	F12	280	4200	64
300	460	410	370	28x12	4	24,5	270	282	342	242	232	500	458	27,8	8	55	F12	750	5700	87
350	520	470	429	28x16	4	26,5	290	339	370	264	280	600	548	35,7	10	65	F14	1250	7800	132
400	580	525	480	31x16	4	28	310	385	431	310	292	700	634	41,7	12	65	F14	1760	13000	158
450	640	585	548	31x20	4	30	330	432	462	340	322	700	668	49,6	16	80	F16	2500	15000	217
500	715	650	609	34x20	4	31,5	350	481	524	379	360	700	641	59,6	18	80	F16	3200	19000	262
600	840	770	720	37x20	5	36	390	576	589	437	422	600	715	59,6	18	110	F25	5100	28000	370
700	910	840	794	37x24	5	39,5	430	675	663	480	458	500	724	79,7	22	110	F25	7200	38000	515
800	1025	950	901	41x24	5	43	470	780	728	548	517	500	776	79,7	22	110	F25	12000	50000	636
900	1125	1050	1001	41x28	5	46,5	510	872	845	614	570	500	940	99,8	28	130	F30	19000	67000	1025
1000	1255	1170	1112	44x28	5	50	550	970	905	665	634	600	989	119,7	32	130	F30	24000	90000	1351
1200	1485	1390	1328	50x32	5	57	630	1157	1025	800	750	600	1322	119,7	32	165	F35	26000	130000	1970

\*Valve torque safety factor is not included



## BUTTERFLY VALVE DOUBLE ECCENTRIC FLANGED FAF 3800



DIMENSIONS - PN10																		RATINGS		
DN (mm)	D	K	d	Øl x n	f	b	L	O	B	C	h	d1	P	R	S	T	TOP FL	VALVE TORQUE * (Nm)	Kv m <sup>3</sup> / h	Weight (kg)
100	220	180	156	19x8	3	19	190	101	183	119	110	100	141	21,7	8	45	F10	60	600	19
150	285	240	211	23x8	3	19	210	148	215	150	145	100	213	21,7	8	45	F10	200	1400	29
200	340	295	266	23x8	3	20	230	200	265	189	172	200	239	21,7	8	45	F10	230	2500	46
250	400	350	319	23x12	3	22	250	248	290	220	205	250	302	27,8	8	55	F12	240	4200	64
300	455	400	370	23x12	4	24,5	270	282	342	242	232	400	408	27,8	8	55	F12	600	5700	93
350	505	460	429	23x16	4	24,5	290	339	366	264	280	600	536	35,7	10	65	F14	900	7800	125
400	565	515	480	28x16	4	24,5	310	385	430	310	292	600	571	41,7	12	65	F14	1040	13000	146
450	615	565	530	28x20	4	25,5	330	432	447	340	322	700	658	49,6	16	80	F16	1800	15000	190
500	670	620	582	28x20	4	26,5	350	481	505	379	360	700	692	59,6	18	80	F16	2000	19000	236
600	780	725	682	31x20	5	30	390	576	584	437	422	600	638	59,6	18	110	F25	2880	28000	350
700	895	840	794	31x24	5	32,5	430	675	636	480	451	500	714	79,7	22	110	F25	4200	38000	515
800	1015	950	901	34x24	5	35	470	780	728	548	517	500	776	79,7	22	110	F25	8000	50000	635
900	1115	1050	1001	34x28	5	37,5	510	872	789	614	564	500	913	99,8	28	130	F30	13700	67000	965
1000	1230	1160	1112	37x28	5	40	550	970	905	665	634	600	989	119,7	32	130	F30	20400	90000	1200
1200	1455	1380	1328	41x32	5	45	630	1157	1025	800	735	600	1322	119,7	32	165	F35	22000	130000	1820

\*Valve torque safety factor is not included.

DIMENSIONS - PN25							
DN (mm)	D	K	d	Øl x n	f	b	L
100	235	190	156	23x8	3	19	190
150	300	250	211	28x8	3	20	210
200	360	310	274	28x12	4	22	230
250	425	370	330	31x12	4	24,5	250
300	485	430	389	31x16	4	27,5	270
350	555	490	448	34x16	4	30	290
400	620	550	503	37x16	4	32	310
450	670	600	548	37x20	4	34,5	330
500	730	660	609	37x20	4	36,5	350
600	845	770	720	41x20	5	42	390
700	960	875	820	44x24	5	46,5	430
800	1085	990	928	50x24	5	51	470
900	1185	1090	1028	50x28	5	55,5	510
1000	1320	1210	1140	57x28	5	60	550

# BUTTERFLY VALVE

## DOUBLE ECCENTRIC FLANGED

### FAF 3800



#### Double Eccentric Flanged Butterfly Valves can be classified according to various designs

1- According to disc design & seating of disc inside the body:

- Centric (Concentric)
- Eccentric
- Double Eccentric
- Triple Eccentric

2- According to drive type:

- Hand Lever
- Manual Gearbox
- Actuated (Electric or Pneumatic)

#### Advantages of Double Eccentric Flanged Butterfly Valve

- Has smaller dimensions and lower weight compared to other valve types.
- Ease of installation with small dimension and lower weight.
- Gearboxes ease opening and closing with low torque.
- No maintenance needed. When sealing ring damaged, can be replaced easily without the need for qualified personnel and special tools. Even, this operation can be done in big size valves without disassembling from the line

#### Points to be considered with Double Eccentric Flanged Butterfly Valve Operation;

- First point, the most appropriate valve needs to be chosen depending on the area of application and conditions.
- In general butterfly valves can be used for regulating and controlling the flow, but should not be used for the purpose of reducing the flow. The waterjets occurring from reduced flow damages the sealing rings and valves lose its sealing properties. In the case where reduced flow is needed, it should be explained clearly and an appropriate design should be arranged conforming this condition.
- Butterfly valves should not be used for discharge purposes. Due to hydrodynamic moments caused by high flow rate during discharge, opening and closing the valve above certain degrees will not be possible. For this kind of applications, conic valves or plunger valves should be used.
- Another point needs to be considered with the usage of butterfly valves is that; these valves are operated with high ratio gearboxes. At many fields, in order to maintain sealing, high forces are applied on the valves, closure is done by attaching an extension pipe to the handwheel. With a right size gearbox, there is no need for such applications. Valve can be opened or closed by one person. When worm gear equipped gearbox on a butterfly valve is closed, disc movement is stopped by the limit pins available on the gearboxes. Forcing beyond this level will not maintain higher sealing in contrary will damage the gearbox.
- In order to ease the installation of butterfly valves, position and place of gearbox can be changed. This point should be informed to our company by the client prior to manufacturing phase.
- Valves should not be used out of the operating pressure, operating temperature and type of fluid mentioned on the manual. In order to prevent the valve from the high pressure and distortion on the system, they should be installed with certain distances from bend and outlet points, this distance can be approximately; 3 to 5 times of valve diameter.
- At places where valves are rarely used, one open/close cycle should be done in every 3-4 months time.

#### Safety Manual for Maintenance, Inspection and Installation Works

For the trouble-free usage of butterfly valves, this manual should be reviewed carefully and information supplied should be applied continuously.

Not following the safety instructions will cause below issues.

- Personal injuries,
- Danger for both environment and valve,
- Malfunction of the major valve / facility functions,
- Failure of the projected maintenance and repair applications,
- Danger to people connected to electrical, mechanical and chemical effects.
- Damage to the environment caused by dangerous leakage,

No modifications or changes can be made to the products supplied by FAF Valve Company. FAF Valve Company shall not be liable for any damages or damages that may result from the failure to comply with the information given in this manual or modification without prior authorization.

Installation, use and maintenance of the butterfly valves should be done with professionally trained people. Although all FAF VANA products are manufactured in accordance with international regulations and standards, valves are potentially hazardous if not used properly or used for purposes other than their intended use.

All responsible personnel for the storage, installation, use, maintenance and disassembly of the valves should carefully read and well understand this document. All international and local safety instructions must be reviewed and understood before taking any action on the valve or pipeline. All necessary precautions must be taken.

If any repairs are to be made, there should be no pressure on the pipeline, and if necessary, all fluid should be drained and warning signs should be placed around the working area.

Devices that can be remotely controlled, such as actuators should be switched to off position. Precautions should be taken to prevent operation of those kind of devices working with stored energy such as compressed air, pressurized water, hydraulic uninterruptible power supply, etc. If a drain valve is to be repaired or uninstalled, precautions must be taken to ensure that the working zone is suddenly filled with water.

The use of original spare parts will ensure the operational safety of the products. The manufacturer can not be held responsible for damage caused by use of non-original parts or accessories.

If a valve needs to be removed, the pipeline should be discharged. The necessary precautions should be taken due to the remaining fluid which will flow freely after the valve has been removed.

Avoid sudden movements during the lifting, moving and lowering of the valve. Sudden movements may damage the valve and/or lifting equipment. The lifting must only be done from the lifting lugs located on the body.

The valve may move involuntarily aside during the lifting operation with a crane. Lifting by crane should be done by a specialist personnel and no one other than the operator should enter the working area during the operation.

Any operation on the actuated valve can be done after the actuator has been removed from the power supply. The procedure described in the operating instructions must be followed to switch off the actuator.

# BUTTERFLY VALVE DOUBLE ECCENTRIC FLANGED FAF 3800



- Before installing the valve, since any possible corrosion, welding particules, dirt and residue may casue deformation on the valve and may casue leakage, remove any such residue from the line by air or steam.
- The pipe centers to which the valve is to be installed must be at the same axis, the counter flanges should be perpendicular to the pipe axis, and the flange bolt holes must be on the same axis. Otherwise, due to axial misalignments, it would cause stress on the valve and would cause leakage!
- If the construction work will continue after the valve installation, the valve should be protected from external factors by placed under suitable protective material. Valve shoulnot be damaged with processes like excavation, paint application, concrete pouring.
- Care must be taken that the flanges connected to the pipeline are not pulled towards the valve when the bolts are tightened. Despite the tensile stresses that may occur, we recommend the use of dismantling joints together with the butterfly valves.
- Allow sufficient space for ease of use, maintenance, disassembly and cleaning of the valve in the chamber where the valve is located.
- Install the valve on the pipeline by using interflange gaskets along with the necessary installation equipments starting with the first side and then the second side without allowing the occurrence of pulling stress. Take out the loseness of bolts and nuts and tighten reciprocally at specified torque values.
- Donot close the valve before cleaning the residue inside the pipe.
- Perform the on/off operation in the directions indicated on the gearbox.
- Valve open and close limit switches on the gearbox are set during production. If necessary, can be readjusted through the setting screws located on the gearbox during comissioning.
- Taking into consideration the nominal pressure marked on the valve; it is necessary to carry out a leakage inspection with 1.1 times of this pressure.

### Replacing The Disc Sealing Ring

Make sure that there is no pressure on the line during disc sealing ring replacement. Attention should be paid to safety regulations.

The sealing ring can be replaced without removing the disc or removing the valve from the pipeline. However, at least the valve should be accessible by detaching it from one of the pipeline side.

Disc should be in fully opened position.

The bolts (7) and the retaining ring (5) should be removed by loosening the bolts reciprocally.

The sealing ring (4) and o-rings (3-6) should be removed.

The new sealing ring (4) and o-rings (3-6) should be assembled to their locations by gently lubricating with approved lubricant.

Bolts must be tightened reciprocally by the torque values specified on the table.

Torque values (Nm) for the disc sealing ring bolts

DN100 DN150	DN200-DN250 DN300	DN350 and DN1200 included
8.7	21.2	42

### Shaft Area O-Ring Replacement

Ensure that there is no pressure on the line. Attention should be paid to safety regulations.

The valve should be accessible by detaching it from one of the pipeline side.

The disc must be in the fully open position.

The gearbox (33) must be detached by removing the bolts and washers (30-31). The key (27) on the shaft should be removed.

The top cover (22) should by detached by removing the bolts (24-23). Remove the bolt(s) (18) on the disc and remove the o-rings(17).

With pulling the main shaft, the main shaft (9), the main shaft bearing (19), the upper bushing (13) should be taken out of the body (1) and the key (8) on the main shaft should not be dropped.

O-rings (11-12-17) should be replaced with new ones, lightly lubricated with approved lubricant and should be fitted in their places.

The reassembly must be followed in reverse order of disassembly, taking care that the top cover face-to-face alignment is well arranged together with the allen key area setscrews (21).

Make sure that the disc and gearbox position indicator match each other.

The bottom cover (22) should be detached by removing the bolts (28-29).

With pulling the support shaft, the support shaft (10), the support shaft bushing (16) and the support shaft bearing (20) should be taken out of the body (1).

O-rings (14-15) should be replaced with new ones, lightly lubricated with approved lubricant and should be fitted to their places.

The reassembly must be followed in reverse order of disassembly, taking care that the bottom cover (26) face-to-face alignment is well arranged together with the allen key area setscrews (25).

- After maintenance, if leakage occurs at closed position, the adjustment can be done with the setscrews (21-25) by loosening the bolts located at bottom and upper cover areas. Afterwards gearbox is assembled through tightening the bolts.

M6	M8	M10	M12	M16	M20	M24	M30
8.7	21.2	42	73	180	370	603	1300

# BUTTERFLY VALVE DOUBLE ECCENTRIC FLANGED FAF 3800



## Troubleshooting

All repair and service works must be carried out by qualified personnel using suitable tools and original spare parts

Problem	Cause	Remedial Action
Valve cannot be operated	Foreign material jammed inside the valve	Fully open the valve and take out the dirt inside the valve
	Gearbox blocked	The gearbox settings must be checked or the gearbox must be turned in the opposite direction
	Electric actuator problem	Check the electrical connection and settings of actuator
Leaks in the body seat	Valve not completely closed	Fully close the valve by checking the mechanical position indicator
	Valve sealing ring worn or damaged	Replace sealing ring
Leaks in valve pipe installation and body	Gaskets damaged	Replace gaskets
	Bolts/nuts are loose	Tighten according to mentioned torque values
Valve makes noise	Valve operating beyond its limits	Check the working conditions and design features. Change valve installation location or change the valve type suitable for the area of usage
	Wrong installation position. (Valve is too close to a reducer, elbow, control valve, etc.)	Change installation position
Torque value very high	Deposit (lime, sand, etc.) accumulation may happened on the body seat	Fully open the valve and clean the deposit
	Pipeline is dry, sealing ring is dry	Apply approved lubricant or silicone on body seat and sealing ring

## Associated Products for the Double Eccentric Flanged Butterfly Valve Range



3960  
FLANGE ADAPTOR

3970  
COUPLING

3900  
DISMANTLING JOINT

5000  
RUBBER  
EXPANSION JOINT

2280  
CHECK VALVE TILTING



3780  
ELECTRIC ACTUATOR



2500  
Y-TYPE STRAINER



7340  
KINETIC ARV



7330  
DYNAMIC ARV