

EC Certificate - Full Quality Assurance System

Directive 93/42/EEC on Medical Devices, Annex II excluding Section 4

No.**CE 615308**

Issued To:

AMPLITUDE**11 Cours Jacques OFFENBACH****ZA Mozart 2****VALENCE****26000****France**

In respect of:

Design, development and manufacture of: hip joint replacement and hemi-hip arthroplasty devices, knee joint replacement devices, osteosynthesis implants, and associated trial prostheses, instruments connecting to active devices and accessories; Computer assisted surgery systems.

on the basis of our examination of the quality assurance system under the requirements of Council Directive 93/42/EEC, Annex II excluding section 4. The quality assurance system meets the requirements of the directive. For the placing on the market of class III products an Annex II section 4 certificate is required.

For and on behalf of BSI, a Notified Body for the above Directive (Notified Body Number 0086):



Stewart Brain, Head of Compliance & Risk -
Medical Devices

First Issued: **2015-04-27**Date: **2018-03-15**Expiry Date: **2022-05-02**

...making excellence a habit.™

Page 1 of 1

Validity of this certificate is conditional on the quality system being maintained to the requirements of the Directive as demonstrated through the required surveillance activities of the Notified Body. This approval excludes all products designed and/or manufactured by a third party on behalf of the company named on this certificate, unless specifically agreed with BSI.
This certificate was issued electronically and is bound by the conditions of the contract.

EC Certificate - Full Quality Assurance System

Directive 93/42/EEC on Medical Devices, Annex II excluding Section 4

List of Significant Subcontractors

Recognised as being involved in services relating to the product covered by:

Certificate No: **CE 615308**
 Date: **2018-03-15**
 Issued To: **AMPLITUDE**
11 Cours Jacques OFFENBACH
ZA Mozart 2
VALENCE
26000
France

Subcontractor:	Service(s) supplied
Acnis International 220 Rue Léon Blum Villeurbanne 69100 France	Crucial Supplier
ATS SAS ZI de Bruèges Avenue Monge BP 80286 Ales Cedex 30106 France	Crucial Supplier Manufacture
Belmonte ZAC des couleurs Chemin du Pau Valence 26000 France	Manufacture

...making excellence a habit.™



EC Certificate - Full Quality Assurance System

Directive 93/42/EEC on Medical Devices, Annex II excluding Section 4

List of Significant Subcontractors

Recognised as being involved in services relating to the product covered by:

Certificate No: **CE 615308**
 Date: **2018-03-15**
 Issued To: **AMPLITUDE**
11 Cours Jacques OFFENBACH
ZA Mozart 2
VALENCE
26000
France

Subcontractor:	Service(s) supplied
Ceramtec CeramTec GmbH Medical Products Division CeramTec Platz 1-9 Plochingen 73207 Germany	Manufacture
DOT GmbH Charles-Darwin-Ring 1 a Rostock 18059 Germany	Other Critical Processes
ENTEGRIS 395, rue Louis Lépine MONTPELLIER 34000 France	Assembly Other Critical Processes Packaging

...making excellence a habit.™

EC Certificate - Full Quality Assurance System

Directive 93/42/EEC on Medical Devices, Annex II excluding Section 4

List of Significant Subcontractors

Recognised as being involved in services relating to the product covered by:

Certificate No: **CE 615308**
Date: **2018-03-15**
Issued To: **AMPLITUDE**
11 Cours Jacques OFFENBACH
ZA Mozart 2
VALENCE
26000
France

Subcontractor:	Service(s) supplied
Eurocoating Via al DOS De La Roda, 60 Pergine Valsugana 38057 Italy	Other Critical Processes Packaging
Firm Industrie ZA Blacheronde d'Etoile Etoile Sur Rhone 26800 France	Manufacture
HTI TECHNOLOGIES 49, Avenue Franklin Roosevelt DECINES 69150 France	Other Critical Processes

...making excellence a habit.™



EC Certificate - Full Quality Assurance System

Directive 93/42/EEC on Medical Devices, Annex II excluding Section 4

List of Significant Subcontractors

Recognised as being involved in services relating to the product covered by:

Certificate No: **CE 615308**
 Date: **2018-03-15**
 Issued To: **AMPLITUDE**
11 Cours Jacques OFFENBACH
ZA Mozart 2
VALENCE
26000
France

Subcontractor:	Service(s) supplied
Invibio Ltd. Invibio Technology Centre Hillhouse International Thornton-Cleveleys Lancashire FY5 4QD United Kingdom	Crucial Supplier
Marle ZI rue Lavoisier Nogent 52800 France	Crucial Supplier Manufacture
Marle Finishing SAS 22 rue de le Mollanche Sorbiers 42290 France	Manufacture Other Critical Processes Packaging

...making excellence a habit.™



EC Certificate - Full Quality Assurance System

Directive 93/42/EEC on Medical Devices, Annex II excluding Section 4

List of Significant Subcontractors

Recognised as being involved in services relating to the product covered by:

Certificate No: **CE 615308**
 Date: **2018-03-15**
 Issued To: **AMPLITUDE**
11 Cours Jacques OFFENBACH
ZA Mozart 2
VALENCE
26000
France

Subcontractor:	Service(s) supplied
Marle Finishing SAS 443 Rue René Cassin La Talaudière 42350 France	Manufacture
MediTECH Medical Polymers Division of Quandrant EPP 2710 American Way Ft. Wayne Indiana 46809 USA	Manufacture
Microweld Parc Altaïs, Rue Uranus CHAVANOD 74650 France	Other Critical Processes

...making excellence a habit.™



EC Certificate - Full Quality Assurance System

Directive 93/42/EEC on Medical Devices, Annex II excluding Section 4

List of Significant Subcontractors

Recognised as being involved in services relating to the product covered by:

Certificate No: **CE 615308**
 Date: **2018-03-15**
 Issued To: **AMPLITUDE**
11 Cours Jacques OFFENBACH
ZA Mozart 2
VALENCE
26000
France

Subcontractor:	Service(s) supplied
Poli Alpes 12, rue Laurent de Lavoisier Portes Les Valence 26800 France	Surface Treatment
Poli-Tech' ZA Blacheronde d'Etoile Etoile Sur Rhone 26800 France	Surface Treatment
Progress Silicones ZI des Bourguignons APT 84400 France	Crucial Supplier

...making excellence a habit.™



EC Certificate - Full Quality Assurance System

Directive 93/42/EEC on Medical Devices, Annex II excluding Section 4

List of Significant Subcontractors

Recognised as being involved in services relating to the product covered by:

Certificate No: **CE 615308**
 Date: **2018-03-15**
 Issued To: **AMPLITUDE**
11 Cours Jacques OFFENBACH
ZA Mozart 2
VALENCE
26000
France

Subcontractor:	Service(s) supplied
S.A.R.L. Devise 6 impasse Aulagnier Portes Les Valence 26800 France	Crucial Supplier
Serret Mecanique 185 Allee De L'Hermitage - Zone Industrielle SUD Bourg De Peage 26300 France	Crucial Supplier
Simagec 54 Avenue de la Plaine Rousset 13106 France	Assembly Other Critical Processes Packaging

...making excellence a habit.™



EC Certificate - Full Quality Assurance System

Directive 93/42/EEC on Medical Devices, Annex II excluding Section 4

List of Significant Subcontractors

Recognised as being involved in services relating to the product covered by:

Certificate No: **CE 615308**
 Date: **2018-03-15**
 Issued To: **AMPLITUDE**
11 Cours Jacques OFFENBACH
ZA Mozart 2
VALENCE
26000
France

Subcontractor:	Service(s) supplied
Societe Mecanique Pansu Quartier de Brezide Beaumont Les Valence 26760 France	Crucial Supplier
STAINLESS 4 rue Thalès Dannmarie-sur-Crete 25410 France	Crucial Supplier
SYNERGY HEALTH MARSEILLE Entrepot Min 712 Les Arnavaux MARSEILLE 13014 France	Gamma Sterilization

...making excellence a habit.™



EC Certificate - Full Quality Assurance System

Directive 93/42/EEC on Medical Devices, Annex II excluding Section 4

List of Significant Subcontractors

Recognised as being involved in services relating to the product covered by:

Certificate No: **CE 615308**
 Date: **2018-03-15**
 Issued To: **AMPLITUDE**
11 Cours Jacques OFFENBACH
ZA Mozart 2
VALENCE
26000
France

Subcontractor:	Service(s) supplied
UDT Meca ZI Les Auréas 5 allée Bernard Palissy Valence 26000 France	Crucial Supplier
VIT RESSORT ZA le Boutariq Rue du Pic de Bure Veynes 05400 France	Crucial Supplier
Westlake Plastics Europe SAS 159 rue de Rotterdam ZAC Ravannes les Francs Bondues 59910 France	Crucial Supplier

...making excellence a habit.™

EC Certificate - Full Quality Assurance System

Certificate History

Certificate No: **CE 615308**
 Date: **2018-03-15**
 Issued To: **AMPLITUDE**
11 Cours Jacques OFFENBACH
ZA Mozart 2
VALENCE
26000
France

Date	Reference number	Action
27 April 2015	8165223	First Issue - Transfer from another Notified Body
08 July 2015	8291732	Extension to scope to include the Trial Prostheses Class IIa devices
09 May 2017	8712742	Certificate Renewal Clarification of scope Addition of significant subcontractors and crucial suppliers: HTI Technologies, MediTECH Medical Polymers (Division of Quandrant EPP), Microweld, Progress Silicones, Stainless and Westlake Plastic Europe SAS Removal of significant subcontractors: MEDICAL Group CORP, MEDIMET and QUADRANT
Current	8906823	Addition of significant subcontractors and crucial suppliers: Poli-Tech', Belmonte, Firm Industrie, Marle Finishing SAS (22 Rue de la Mollanche & 443 Rue René Cassin), Poli Alpes, UDT Meca, Societe Mecanique Pansu, Serret Mecanique and S.A.R.L. Devise. Address changes to VIT RESSORT from 'Chemin de Vignes, Veynes, 05400, France' to 'ZA le Boutariq, Rue du Pic de Bure, 05400 Veynes, France' and to CeramTech from 'Fabrikstrasse 23-29, Plochingen, 73207, Germany' to 'CeramTec GmbH, Medical Products Division, CeramTec Platz 1-9, 73207 Plochingen, Germany'

...making excellence a habit.™

Page 1 of 1

Validity of this certificate is conditional on the quality system being maintained to the requirements of the Directive as demonstrated through the required surveillance activities of the Notified Body. This approval excludes all products designed and/or manufactured by a third party on behalf of the company named on this certificate, unless specifically agreed with BSI.
 This certificate was issued electronically and is bound by the conditions of the contract.

Information and Contact: BSI, Kitemark Court, Davy Avenue, Knowlhill, Milton Keynes MK5 8PP. Tel: +44 345 080 9000
 BSI Assurance UK Limited, registered in England under number 7805321 at 389 Chiswick High Road, London W4 4AL, UK.
 A member of BSI Group of Companies.



FREELINER[®]

Cementless cup

BIOLOX[®] delta ceramic liner

PEXEL-E[®] liner



- Cementless cup with screw
- Porous coating ensures primary stability
- Can be used with PE or ceramic liner
- Cup oversizing provides +1.26 mm to 1.66 mm press-fit
- Material: Titanium and dual coating of plasma-sprayed titanium (400–600 µm) and HA (80 µm)

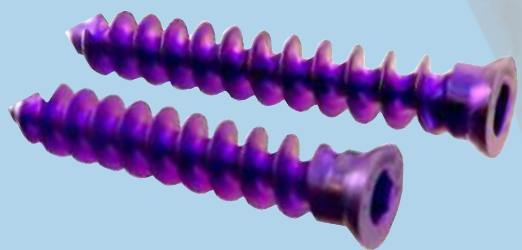

- Ø6 mm fixation screw (aligned towards roof of cup) to reinforce primary fixation
- Up to 4 screws can be added per cup
- 20° angular displacement in cup
- Material: Titanium

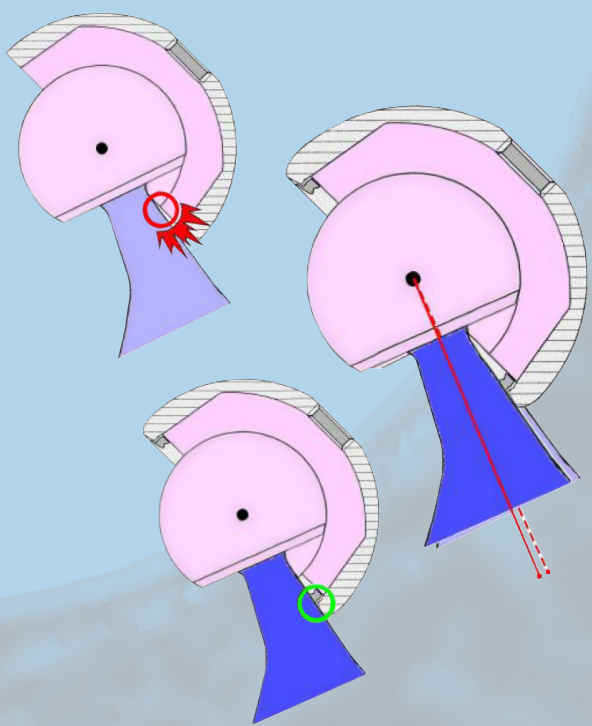

- Cup has a 2.6 mm equatorial rim that:
 - prevents contact between neck of stem and edge of ceramic liner
 - maintains PEXEL-E liner orientation
- Presence of rim results in stem losing only 2° angular displacement



- BIOLOX® delta liner for ceramic-on-ceramic bearing option
- Morse taper fixation with cup allows liner to be extracted by resonance
- Advantages of BIOLOX® delta ceramic:
 - improved strength due to reduced grain size and increased density⁽¹⁾
 - ceramic liner for Ø32 mm and Ø36 mm heads



- Vitamin E highly crosslinked PE liners (PEXEL-E®)
- Vitamin E prevents oxidation of highly crosslinked PE, thereby preventing premature wear⁽²⁾
- Peripheral 20° chamfer:
 - delays impingement
 - provides flat surface for neck contact
- Fixation using anti-rotation tabs that clip into cup rim
- Crosslinking obtained with 100 kGy gamma ray dose
- Polyethylene liners for Ø32 mm and Ø36 mm

⁽¹⁾ BIOLOX® Delta "Scientific Information and Performance Data", MT140034 - EN - 2.000 - 1501
⁽²⁾ "Future Bearing Surfaces in Total Hip Arthroplasty", Jun-Dong Chang, Clinics in Orthopedic Surgery 2014;6:110-116

FREELINER® Ti+HA press-fit cup Ø46 conical inside Ø40	H75 4640
FREELINER® Ti+HA press-fit cup Ø48 conical inside Ø40	H75 4840
FREELINER® Ti+HA press-fit cup Ø50 conical inside Ø44	H75 5044
FREELINER® Ti+HA press-fit cup Ø52 conical inside Ø44	H75 5244
FREELINER® Ti+HA press-fit cup Ø54 conical inside Ø48	H75 5448
FREELINER® Ti+HA press-fit cup Ø56 conical inside Ø48	H75 5648
FREELINER® Ti+HA press-fit cup Ø58 conical inside Ø50	H75 5850
FREELINER® Ti+HA press-fit cup Ø60 conical inside Ø50	H75 6050
FREELINER® Ti+HA press-fit cup Ø62 conical inside Ø54	H75 6254

FREELINER® ceramic liner 32/40 Z	H75 C4032
FREELINER® ceramic liner 36/44 Z	H75 C4436
FREELINER® ceramic liner 36/48 Z	H75 C4836
FREELINER® ceramic liner 36/50 Z	H75 C5036
FREELINER® ceramic liner 36/54 Z	H75 C5436

FREELINER® PEXEL-E liner 40/32	H75 XE4032
FREELINER® PEXEL-E liner 44/32	H75 XE4432
FREELINER® PEXEL-E liner 48/36	H75 XE4836
FREELINER® PEXEL-E liner 50/36	H75 XE5036
FREELINER® PEXEL-E liner 54/36	H75 XE5436

TA6V 6 mm Cancellous Screw, Lg 20 mm	H15 SB6020
TA6V 6 mm Cancellous Screw, Lg 25 mm	H15 SB6025
TA6V 6 mm Cancellous Screw, Lg 30 mm	H15 SB6030
TA6V 6 mm Cancellous Screw, Lg 35 mm	H15 SB6035
TA6V 6 mm Cancellous Screw, Lg 40 mm	H15 SB6040
TA6V 6 mm Cancellous Screw, Lg 45 mm	H15 SB6045
TA6V 6 mm Cancellous Screw, Lg 50 mm	H15 SB6050

Optional

FREELINER® Ti+HA press-fit cup Ø64 conical inside Ø54	H75 6454
FREELINER® Ti+HA press-fit cup Ø66 conical inside Ø 54	H75 6654
FREELINER® PEXEL-E liner 44/36	H75 XE4436

REPUBLICA



MOLDOVA

CERTIFICAT DE ÎNREGISTRARE

PRIN PREZENTUL SE CERTIFICĂ, CĂ ÎNTREPRINDEREA
MIXTĂ "GBG-MLD" S.R.L. ESTE ÎNREGISTRATĂ LA CAMERA
ÎNREGISTRĂRII DE STAT

Numărul de indentificare de stat - codul fiscal

1003600117582

Data înregistrării

06.01.1995

Data eliberării

21.12.2004

Iovu Galina, registrator de stat

*Funcția, numele, prenumele persoanei
care a eliberat certificatul*

G. Iovu
semnătura

MD 0006733





ALL CERT SYSTEMS

CERTIFICAT SERIA C Nr. 03304, rev. 0



QMS No 0102 A
EMS No 0037D
ISMS No 0010G
FSMS No 0010I

Membro degli Accordi di Mutuo Riconoscimento EA, IAF e ILAC

Signatory of EA, IAF and ILAC Mutual Recognition Agreements

se certifica Sistemul de Management al Calitatii stabilit, implementat si mentinut in cadrul

GBG-MLD S.R.L.

Sediu social: Str. Tighina, Nr. 65, Mun. Chisinau, Republica Moldova

cu urmatoarele sedii operative

Str. Tighina, Nr. 65, Mun. Chisinau, Republica Moldova

conform cu cerintele

SR EN ISO 9001: 2015 (ISO 9001:2015)

pentru urmatoarele activitati

comercializarea articolelor de tehnica medicala

Data acordarii: 27.02.2019

Emis la: Milano, Via Ferdinando Marescalchi, nr. 9,
CAP 20133, Italia
Sectoare IAF: 29

All Cert Systems este organism acreditat de Organismul de acreditare ACCREDIA pentru certificarea sistemului de management al calitatii conform certificatului nr. 102A si anexei insotitoare.

Scaneaza QR codul alaturat pentru a verifica validitatea prezentului certificat pe site-ul www.allcert.ro



**Eliberat de
Monica Pescaru
Director General
All Cert Systems**

Valabil pana la: 26.02.2022

Acest document este valabil insotit de Anexa si doar in conditiile finalizarii auditului de supraveghere si vizarii anuale a prezentului certificat.



Valid pana la:
26/02/2020



Valid pana la:
26/02/2021



Valid pana la:
26/02/2022

ANEXA LA CERTIFICATUL SERIA C NUMAR 03304, rev. 0

GBG-MLD S.R.L.

Sediul social: Str. Tighina, Nr. 65, Mun. Chisinau, Republica Moldova

Domeniu: comercializarea articolelor de tehnica medicala

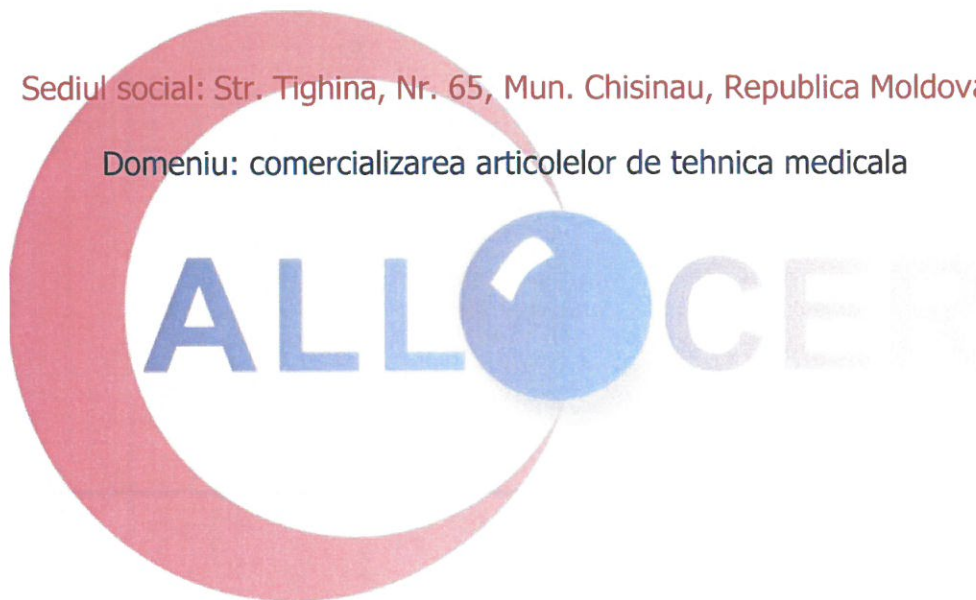

Data acordarii: 27.02.2019

Valabil până la: 26.02.2022

A handwritten signature in black ink, appearing to be 'Monica Pescaru', written over a faint circular stamp.



Valid pana la:
26/02/2020



Valid pana la:
26/02/2021



Valid pana la:
26/02/2022

Director General: Monica Pescaru



REPUBLICA MOLDOVA

LICENȚĂ

Seria A MMII

Nr. 048120

Denumirea autorității de licențiere

Camera de Licențiere

Denumirea, forma juridică de organizare, sediul (adresa juridică) a titularului de licență

Societatea cu Răspundere Limitată
„GBG-MLD”

mun. Chișinău, str. Tighina, 65

Data și numărul certificatului de înregistrare de stat a titularului de licență

02.03.2015

Numărul de înregistrare a întreprinderii sau IDNO

1003600117582

Codul fiscal

Genul de activitate, integral sau parțial, pentru a cărui desfășurare se eliberează licența

* Importul, comercializarea dispozitivelor medicale și opticii *

Data eliberării licenței

26 mai 2005

Valabilă pînă la
Prelungită pînă la: 26.05.2015
Prelungită pînă la: 25.05.2020

26 mai 2010

Semnătura conducătorului autorității de licențiere

Director al Camerei de Licențiere

Valentin GUZNAC



Notă: Licența este valabilă numai cu anexa autenticată de autoritatea de licențiere, în care sînt indicate condițiile de licențiere pentru genul de activitate specificat în licență.

ANEXĂ LA LICENȚA

Seria A MMII

Nr. 048120

Titular de licență Societatea cu Răspundere Limitată „GBG-MLD”

Titularul de licență este obligat să respecte următoarele condiții de licențiere pentru desfășurarea activității:
*** Importul, comercializarea dispozitivelor medicale și opticii ***

Reperfectată: 1)08.05.2014,2)10.03.2015

1. Desfășurarea activității licențiate în conformitate cu cadrul legislativ și normativ.
2. Asigurarea efectuării controlului metrologic legal a mijloacelor de măsurare, utilizate în domeniul sănătății și siguranței populației.
3. Indicarea la loc vizibil al prețurilor la mărfuri și a tarifelor pentru servicii într-o formă clară.
4. Deținerea autorizației sanitare, antiincendiare, ecologice și de securitate a muncii.
5. Disponerea de spații cu titlu de proprietate sau de locațiune pentru desfășurarea activității licențiate.
6. Disponerea de specialiști în domeniu (ingineri, bioingineri).

Activitatea licențiată se desfășoară pe adresa:

mun. Chișinău, str. Tighina, 65

Licența este valabilă cu următorul specialist - Ceaicovschi Tudor

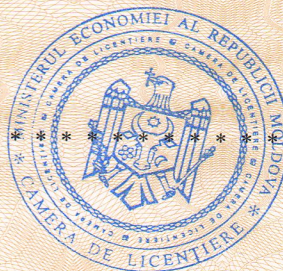

L.Ș.

Notă: Anexa și copiile ei sînt valabile numai cu ștampila originală a autorității de licențiere.

Certificate of Registration

QUALITY MANAGEMENT SYSTEM - ISO 13485:2016 & EN ISO 13485:2016

This is to certify that:

AMPLITUDE
11 Cours Jacques Offenbach
ZA Mozart 2
VALENCE
26000
France

Holds Certificate Number:

MD 615264

and operates a Quality Management System which complies with the requirements of ISO 13485:2016 & EN ISO 13485:2016 for the following scope:

Design, manufacturing and distribution of orthopaedic/joint implants, surgical instruments and computer assisted surgery systems.

Previous certificate expires on 28/02/2019.
Transition audit ended 28/11/2018.



For and on behalf of BSI:

Stewart Brain, Head of Compliance & Risk - Medical Devices

Original Registration Date: 2015-04-25

Latest Revision Date: 2019-02-28

Effective Date: 2019-02-28

Expiry Date: 2022-02-27

Page: 1 of 1



003

...making excellence a habit.™

EVOK®

Straight Cementless
Femoral Stem



AMPLITUDE®

EVOK[®] Main Features

- **Straight stem**
Cementless version
- Three versions: **Standard, Lateralized, High Offset**
Collared stems available for Standard and Lateralized versions
- Double wedge taper stem
- **Quadrangular** cross-section with rounded edges

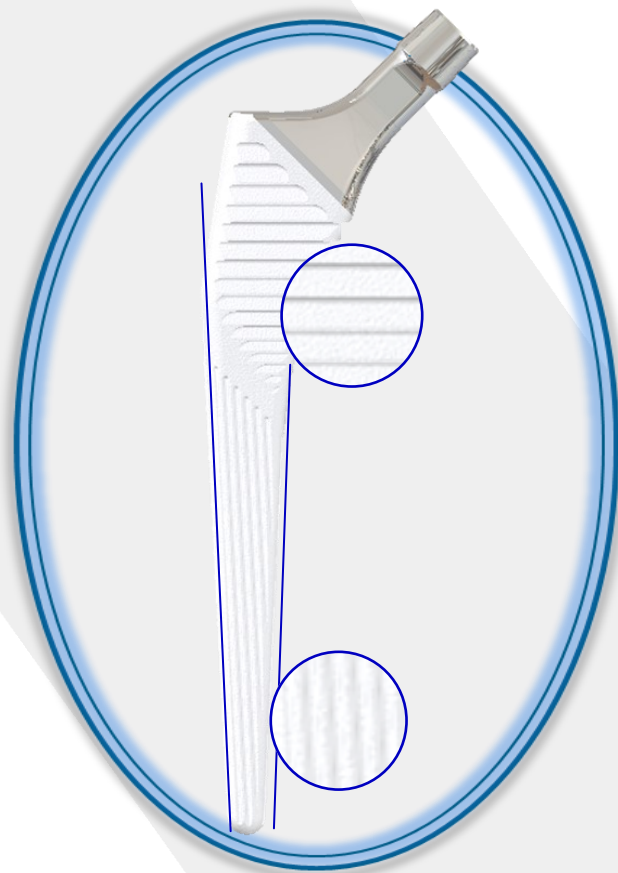
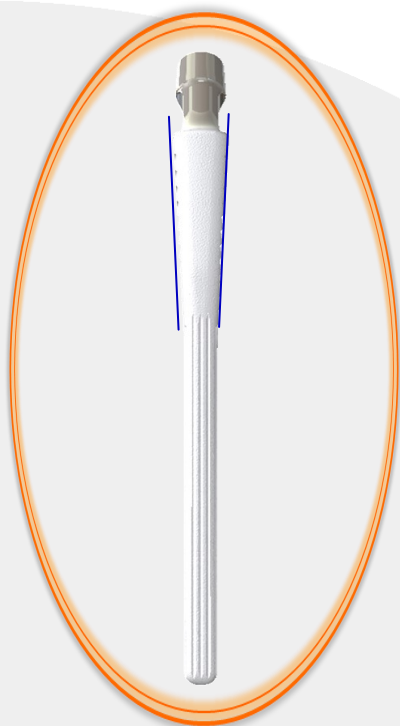

- Reduced lateral flange for ease of insertion
- Proximal horizontal grooves and distal vertical grooves increasing contact area with bone.
- **Material:** Titanium alloy TA6V
- **Coating:** HA 155 μm
Full HA coating on intra-medullary part

- **CCD angles:**
 - Standard version: 135°
 - High Offset version: 135°
 - Lateralized version: evolves from 126,2° to 129,9°
- **Flat surface on under-taper area:** +10° range of motion compared to a cylindrical shape
- Collar starting in the distal internal axis of stem
- **12/14 taper**



8 to 12 sizes depending on version

Standard stem:

L = 91 to 171 mm
 C = 38,5 mm
 CCD angle = 135°

H = 35,9 mm
 O = 37,5 to 45,9 mm

Lateralized stem:

L = 96 to 171 mm
 C = 41,3 to 45,1 mm
 CCD angle = 126,2° to 129,9°

H = 31,4 to 35,9 mm
 O = 45,9 to 54,9 mm

High Offset stem:

L = 111 to 151 mm
 C = 43,2 mm
 CCD angle = 135°

H = 35,9 mm
 O = 45,8 to 50,3 mm

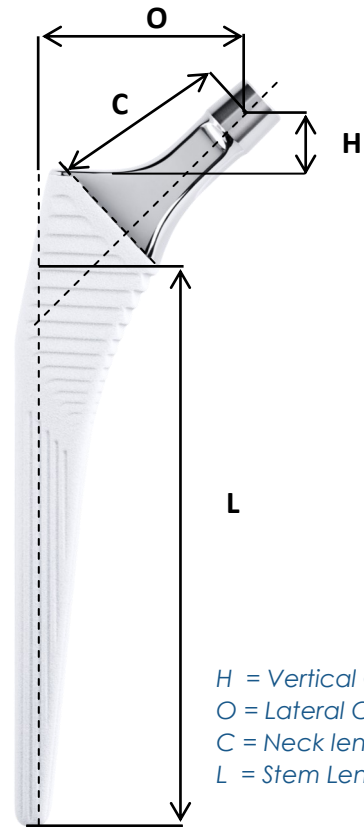

Links between options:

Standard versus High Offset

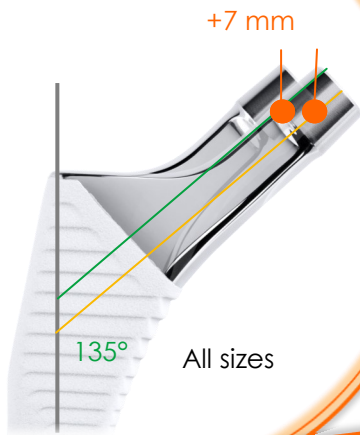

Standard versus Lateralized

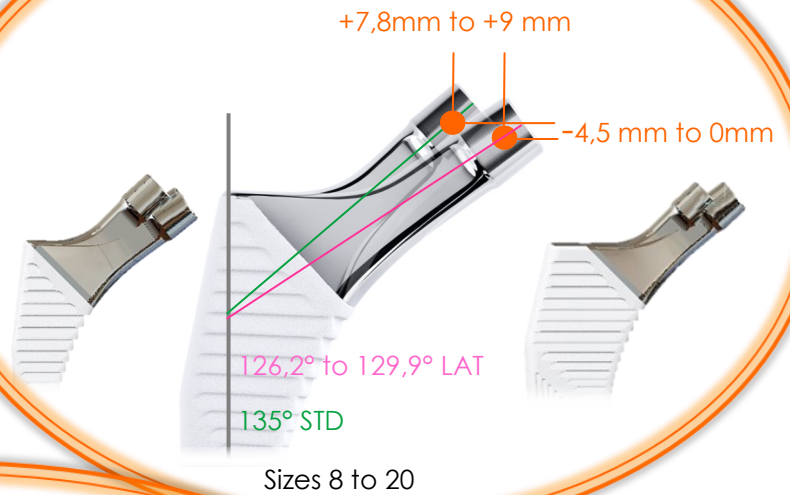

High Offset versus Lateralized

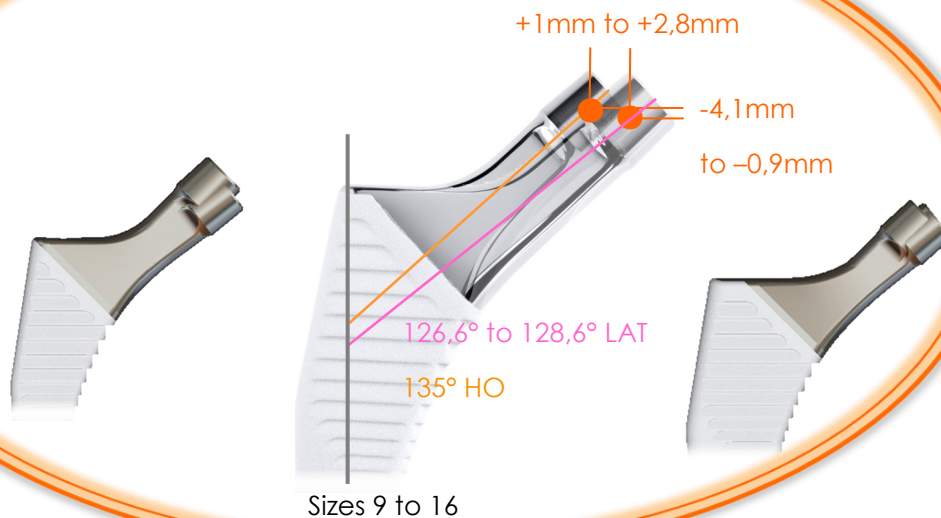

EVOK® Standard

Femoral stem EVOK® 12/14 standard Collarless	1-0192007	Femoral stem EVOK® 12/14 standard Collared	1-0192107
Femoral stem EVOK® 12/14 standard Collarless	1-0192008	Femoral stem EVOK® 12/14 standard Collared	1-0192108
Femoral stem EVOK® 12/14 standard Collarless	1-0192009	Femoral stem EVOK® 12/14 standard Collared	1-0192109
Femoral stem EVOK® 12/14 standard Collarless	1-0192010	Femoral stem EVOK® 12/14 standard Collared	1-0192110
Femoral stem EVOK® 12/14 standard Collarless	1-0192011	Femoral stem EVOK® 12/14 standard Collared	1-0192111
Femoral stem EVOK® 12/14 standard Collarless	1-0192012	Femoral stem EVOK® 12/14 standard Collared	1-0192112
Femoral stem EVOK® 12/14 standard Collarless	1-0192013	Femoral stem EVOK® 12/14 standard Collared	1-0192113
Femoral stem EVOK® 12/14 standard Collarless	1-0192014	Femoral stem EVOK® 12/14 standard Collared	1-0192114
Femoral stem EVOK® 12/14 standard Collarless	1-0192015	Femoral stem EVOK® 12/14 standard Collared	1-0192115
Femoral stem EVOK® 12/14 standard Collarless	1-0192016	Femoral stem EVOK® 12/14 standard Collared	1-0192116
Femoral stem EVOK® 12/14 standard Collarless	1-0192018	Femoral stem EVOK® 12/14 standard Collared	1-0192118
Femoral stem EVOK® 12/14 standard Collarless	1-0192020	Femoral stem EVOK® 12/14 standard Collared	1-0192120

EVOK® Lateralized

Femoral stem EVOK® 12/14 Lateralized Collarless	1-0192208	Femoral stem EVOK® 12/14 Lateralized Collared	1-0192308
Femoral stem EVOK® 12/14 Lateralized Collarless	1-0192209	Femoral stem EVOK® 12/14 Lateralized Collared	1-0192309
Femoral stem EVOK® 12/14 Lateralized Collarless	1-0192210	Femoral stem EVOK® 12/14 Lateralized Collared	1-0192310
Femoral stem EVOK® 12/14 Lateralized Collarless	1-0192211	Femoral stem EVOK® 12/14 Lateralized Collared	1-0192311
Femoral stem EVOK® 12/14 Lateralized Collarless	1-0192212	Femoral stem EVOK® 12/14 Lateralized Collared	1-0192312
Femoral stem EVOK® 12/14 Lateralized Collarless	1-0192213	Femoral stem EVOK® 12/14 Lateralized Collared	1-0192313
Femoral stem EVOK® 12/14 Lateralized Collarless	1-0192214	Femoral stem EVOK® 12/14 Lateralized Collared	1-0192314
Femoral stem EVOK® 12/14 Lateralized Collarless	1-0192215	Femoral stem EVOK® 12/14 Lateralized Collared	1-0192315
Femoral stem EVOK® 12/14 Lateralized Collarless	1-0192216	Femoral stem EVOK® 12/14 Lateralized Collared	1-0192316
Femoral stem EVOK® 12/14 Lateralized Collarless	1-0192218	Femoral stem EVOK® 12/14 Lateralized Collared	1-0192318
Femoral stem EVOK® 12/14 Lateralized Collarless	1-0192220	Femoral stem EVOK® 12/14 Lateralized Collared	1-0192320

EVOK® High Offset

Femoral stem EVOK® 12/14 high offset Collarless	1-0194709	Femoral stem EVOK® 12/14 high offset Collarless	1-0194713
Femoral stem EVOK® 12/14 high offset Collarless	1-0194710	Femoral stem EVOK® 12/14 high offset Collarless	1-0194714
Femoral stem EVOK® 12/14 high offset Collarless	1-0194711	Femoral stem EVOK® 12/14 high offset Collarless	1-0194715
Femoral stem EVOK® 12/14 high offset Collarless	1-0194712	Femoral stem EVOK® 12/14 high offset Collarless	1-0194716

	Short neck	Medium neck	Long neck	Extra-long neck
Metallic femoral head M30NW—Taper 12/14—Ø22,2 mm	1-0190701	1-0190702	1-0190703	-
Metallic femoral head M30NW—Taper 12/14—Ø28 mm	1-0190711	1-0190712	1-0190713	1-0190714
Metallic femoral head M30NW—Taper 12/14—Ø32 mm	1-0190721	1-0190722	1-0190723	1-0190724
Ceramic femoral head —Taper 12/14—Ø28 mm	1-0190911	1-0190912	1-0190913	-
Ceramic femoral head —Taper 12/14—Ø32 mm	1-0190921	1-0190922	1-0190923	1-0190924
Ceramic femoral head —Taper 12/14—Ø36 mm	1-0190931	1-0190932	1-0190933	1-0190934

Creation date : September 2017 – Legal manufacturer : AMPLITUDE, 11 cours Jacques Offenbach, 26000 Valence, France - Destination : replacement of hip joint in association with an acetabular component

Service Clients-France :

Porte du Grand Lyon,
01700 Neyron, France
Tel. : +33 (0)4 37 85 19 19
Fax : +33 (0)4 37 85 19 18

Customer Service-Export :

11, cours Jacques Offenbach. Zone Mozart 2,
26000 Valence, France
Tel. : +33 (0)4 75 41 87 41
Fax : +33 (0)4 75 41 87 42

E-mail : amplitude@amplitude-ortho.com

Internet : www.amplitude-ortho.com

AMPLIFIX 1 AMPLIFIX 3

AMPLIFIX 1
GENTAMICINE

CIMENT CHIRURGICAL AVEC ANTIBIOTIQUE
VISCOSITÉ STANDARD - Mode d'application : Manuelle
RADIO-OPAQUE

BONE CEMENT WITH ANTIBIOTIC
STANDARD VISCOSITY - Digital use
RADIOPAQUE

CEMENTO QUIRÚRGICO CON ANTIBIÓTICO
VISCOSIDAD ESTÁNDAR - Modo de aplicación : Manual
RADIO-OPACA

CHIRURGISCHER ZEMENT MIT ANTIBIOTIKUM
STANDARD VISKOSITÄT - Anwendungsweise : manuell
RÖNTGENPOSITIV

CEMENTO CHIRURGICO CON ANTIBIOTICO
VISCOSITA' STANDARD
Modo d'applicazione : manuale
RADIO-OPACO

AMPLITUDE  **STERILE**

AMPLIFIX 3
GENTAMICINE

CIMENT CHIRURGICAL AVEC ANTIBIOTIQUE
BASSE VISCOSITÉ - Mode d'application : Seringue
RADIO-OPAQUE

BONE CEMENT WITH ANTIBIOTIC
LOW VISCOSITY - syringe use
RADIOPAQUE

CEMENTO QUIRÚRGICO CON ANTIBIÓTICO
BAJA VISCOSIDAD - Modo de aplicación : Seringuilla
RADIO-OPACA

CHIRURGISCHER ZEMENT MIT ANTIBIOTIKUM
NIEDRIGE VISKOSITÄT - Anwendungsweise : Spritze
RÖNTGENPOSITIV

CEMENTO CHIRURGICO CON ANTIBIOTICO
BASSA VISCOSITA'
Modo d'applicazione : siringa
RADIO-OPACO

AMPLITUDE  **STERILE**



AMPLIFIX 1 and 3
AMPLIFIX 1 and 3 with
Gentamicin
Surgical cement

AMPLIFIX 1 and 3

CE 0086

fabricant Teknimed sa

Amplifix 1
Amplifix 3

Surgical cement - Standard Viscosity
Surgical cement - Low Viscosity

1-0400101
1-0400103

AMPLIFIX 1 and 3 Gentamicin

Amplifix 1 gentamicin
Amplifix 3 gentamicin

Surgical cement with gentamicin - Standard Viscosity
Surgical cement with gentamicin - Low Viscosity

1-0400201
1-0400203

Packaging

- MONOMER : sterile liquid ampoule
- POLYMER : sterile bag powder (40 grams)

Protected by a double-sterile bag

- STORAGE : maximum temperature of 25 °C

Accessories

Cup
Syringe

non-sterile disposable
non-sterile disposable

To60404
To60402

Distributed by :

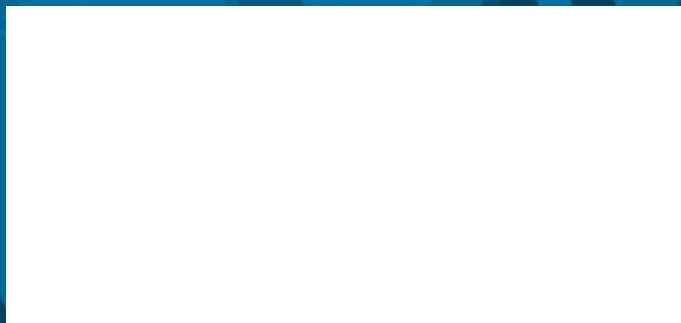

AMPLITUDE 

Customer Service — France: Porte du Grand Lyon, 01700 Neyron — France — Tel.: +33 (0)4 37 85 19 19, Fax: +33 (0)4 37 85 19 18

Customer Service — Export: 11, cours Jacques Offenbach, Zone Mozart 2, 26000 Valence — France — Tel.: +33 (0)4 75 41 87 41, Fax: +33 (0)4 75 41 87 42

E-mail: amplitude@amplitude-ortho.com

Internet: www.amplitude-ortho.com

Gamme de tiges EVOK®

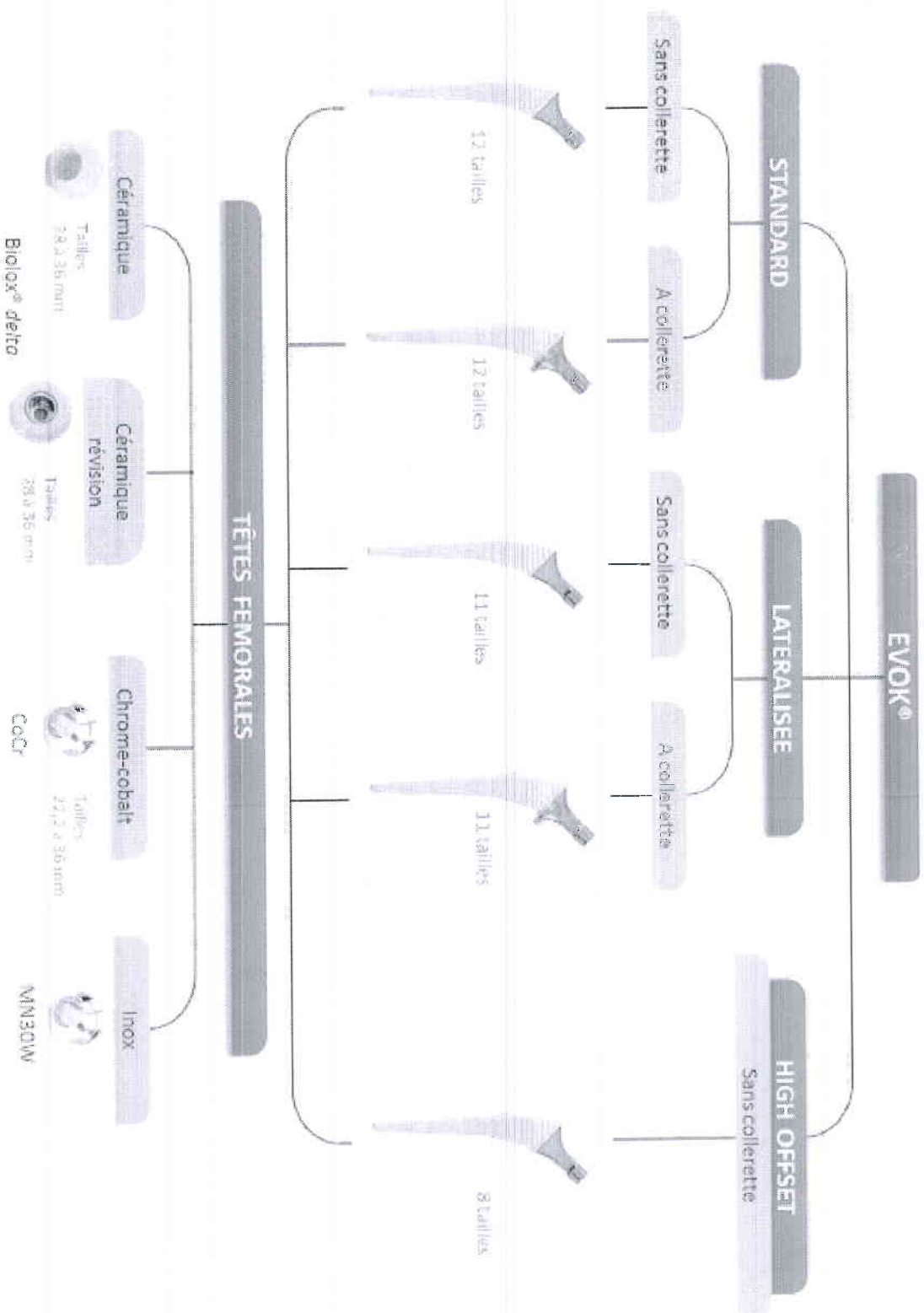

" 26.03.19 20 "

Data primirii



Anexe la SNC
 "Prezentarea situatiilor financiare"
 Aprobata de Ministerul Finantelor
 al Republicii Moldova

SITUAȚIILE FINANCIARE

pentru perioada 01 ianuarie 2018 - 31 decembrie 2018

Entitatea <u>GBG-MLD SRL</u> (Denumirea completa) Sediul: <u>MD2001, mun. Chisinau, str. Tighina 65, RM</u> Cod postal, Raionul (mun, UTA); Localitatea, strada, nr, bl. Activitatea principala <u>Comert</u> Forma de proprietate <u>PRIVATA</u> Forma organizatorico-juridica <u>Societate cu Raspundere Limitata</u> Date de contact: <u>Tel. (022) 54-73-73; e-mail: angels@gbg.md</u> WEB_	<table border="0" style="width: 100%;"> <tr> <td style="width: 30%;">Cod CUIIO</td> <td style="text-align: right;">37421920</td> </tr> <tr> <td>Cod IDNO</td> <td style="text-align: right;">1003600117582</td> </tr> <tr> <td>Cod CUATM</td> <td style="text-align: right;">0130</td> </tr> <tr> <td>Cod CAEM, rev.2</td> <td style="text-align: right;">G4646</td> </tr> <tr> <td>Cod CAEM, editia 2004</td> <td style="text-align: right;">51460</td> </tr> <tr> <td>Cod CFP</td> <td style="text-align: right;">15</td> </tr> <tr> <td>Cod CFOJ</td> <td style="text-align: right;">530</td> </tr> </table>	Cod CUIIO	37421920	Cod IDNO	1003600117582	Cod CUATM	0130	Cod CAEM, rev.2	G4646	Cod CAEM, editia 2004	51460	Cod CFP	15	Cod CFOJ	530
Cod CUIIO	37421920														
Cod IDNO	1003600117582														
Cod CUATM	0130														
Cod CAEM, rev.2	G4646														
Cod CAEM, editia 2004	51460														
Cod CFP	15														
Cod CFOJ	530														

Numele și coordonatele al contabilului-Sef: Dl (dna) **Munteanu Angela**
 Tel.: **078053310**

Unitatea de masura: leu

Anexa 8

Nota informativa privind veniturile si cheltuielile clasificate dupa natura

Indicatori	Cod rd.	Perioada de gestiune	
		precedenta	curenta
1	2	3	4
Venituri din vinzari	010	126 318 597	114 222 442
Alte venituri din activitatea operationala	020	1 447 184	502 592
Venituri din alte activitati	030	1 912 269	1 248 636
Total venituri (rd.010 + rd.020 + rd.030)	040	129 678 050	115 973 670
Variatia stocurilor	050		
Costul vinzarilor marfurilor vindute	060	91 486 732	88 230 050
Cheltuieli privind stocurile	070		
Cheltuieli cu personalul privind remunerarea muncii	080	4 925 496	4 860 528
Contributii de asigurari sociale de stat obligatorii si prime de asigurare obligatorie de asistenta medicala	090	1 344 482	1 037 634
Cheltuieli cu amortizarea si deprecierea activelor imobilizate	100	782 580	914 436
Alte cheltuieli	110		
Cheltuieli din alte activitati	120	6 040 046	6 641 198
Total cheltuieli (rd.050 + rd.060 + rd.070 + rd.080 + rd.090 + rd.100 + rd.110 + rd.120)	130	106 418 000	102 897 481
Profit (pierdere) pina la impozitare (rd.040 - rd.130)	140	23 260 050	13 076 189
Cheltuieli privind impozitul pe venit	150	3 112 701	1 924 619
Profit (pierdere) net al perioadei de gestiune (rd.140 - rd.150)	160	20 147 349	11 151 570

BILANȚUL
la 31 decembrie 2018

Anexa 1

ACTIV	Cod rd.	Sold la	
		Inceputul perioadei de gestiune	Sfirsitul perioadei de gestiune
2	3	4	5
Active imobilizate			
Imobilizari necorporale	010	123 695	106 570
Imobilizari corporale in curs de executie	020		
Terenuri	030		
Mijloace fixe	040	3 011 265	4 455 283
Resurse minerale	050		
Active biologice imobilizate	060		
neafiliate	070		
Investitii financiare pe termen lung in parti afiliate	080		
Investitii imobiliare	090		
Creante pe termen lung	100		
Avansuri acordate pe termen lung	110		
Alte active imobilizate	120		
Total active imobilizate (rd.010 + rd.020 + rd.030 + rd.040 + rd.050 + rd.060 + rd.070 + rd.080 + rd.090 + rd.100 + rd.110 + rd.120)	130	3 134 960	4 561 853
Active circulante			
Materiale	140	8 453	12 720
Active biologice circulante	150		
Obiecte de mica valoare Si scurta durata	160	47 386	50 517
Productia in curs de executie Si produse	170		
Marfuri	180	22 143 505	20 425 496
Creante comerciale	190	65 493 799	59 654 200
Creante ale partilor afiliate	200		
Avansuri acordate curente	210	610 670	3 244 618
Creante ale bugetului	220	60 434	130 482
Creante ale personalului	230	1 912	
Alte creante curente	240		
Numerar in casierie si la conturi curente	250	1 001 169	2 298 556
Alte elemente de numerar	260	4 603	9 214
Investitii financiare curente in parti neafiliate	270		
Investitii financiare curente in parti afiliate	280		
Alte active circulante	290	59 769	65 904
Total active circulante (rd.140 + rd.150 + rd.160 + rd.170 + rd.180 + rd.190 + rd.200 + rd.210 + rd.220 + rd.230 + rd.240 + rd.250 + rd.260 + rd.270 + rd.280 + rd.290)	300	89 431 700	85 891 707
Total active (rd.130 + rd.300)	310	92 566 660	90 453 560

P A S I V	Cod rd.	Sold la	
		Inceputul perioadei de gestiune	Sfârșitul perioadei de gestiune
2	3	4	5
Capital propriu			
Capital social și suplimentar	320	5 400	5 400
Rezerve	330	803 868	803 868
Corectii ale rezultatelor anilor precedent	340		
Profit nerepartizat (pierdere neacoperita) al anilor precedent	350	33 964 874	33 964 874
Profit net (pierdere neta) al perioadei de gestiune	360		11 151 570
Profit utilizat al perioadei de gestiune	370		
Alte elemente de capital propriu	380		
Total capital propriu (rd.320 + rd.330 + rd.340 + rd.350 + rd.360 - rd.370 + rd.380)	390	34 774 142	45 925 712
Datorii pe termen lung			
Credite bancare pe termen lung	400		
Imprumuturi pe termen lung	410		
Datorii pe termen lung privind leasingul financiar	420		
Alte datorii pe termen lung	430		
Total datorii pe termen lung (rd.400 + rd.410 + rd.420 + rd.430)	440		
Datorii curente			
Credite bancare pe termen scurt	450		
Imprumuturi pe termen scurt	460	1 356 000	
Datorii comerciale	470	13 234 389	12 015 004
Datorii fata de partile afiliate	480		
Avansuri primite curente	490	578 815	72 088
Datorii fata de personal	500		
Datorii privind asigurarile sociale si medicale	510		
Datorii fata de buget	520	2 390 651	223 650
Venituri anticipate curente	530		
Datorii fata de proprietari	540	40 133 470	32 162 265
Finantari și incasari cu destinatie speciala curente	550		
Provizioane curente	560		
Alte datorii curente	570	99 193	54 841
Total datorii curente (rd.450 + rd.460 + rd.470 + rd.480 + rd.490 + rd.500 + rd.510 + rd.520 + rd.530 + rd.540 + rd.550 + rd.560 + rd.570)	580	57 792 518	44 527 848
Total pasive (rd.390 + rd.440 + rd.580)	590	92 566 660	90 453 560

SITUAȚIA DE PROFIT ȘI PIERDERE
de la 01 ianuarie pînă 31 decembrie 2018

DIRECȚIA GENERALĂ
PENTRU STATISTICĂ

26. MAR. 2019

Anexa 2

MUNICIPIULUI CHIȘINĂU

Indicatori	Cod rd.	Perioada de gestiune	
		precedenta	curenta
1	2	3	4
Venturi din vânzări	010	126 318 597	114 222 442
Costul vânzării	020	91 486 732	88 230 050
Profit brut (pierdere brută) (rd.010 - rd.020)	030	34 831 865	25 992 392
Alte venituri din activitatea operațională	040	1 447 184	502 592
Cheltuieli de distribuție	050	1 303 019	1 086 195
Cheltuieli administrative	060	10 195 119	10 453 985
Alte cheltuieli din activitatea operațională	070	1 594 467	1 913 617
Rezultatul din activitatea operațională: profit (pierdere) (rd.030 + rd.040 - rd.050 - rd.060 - rd.070)	080	23 186 444	13 041 187
Rezultatul din alte activități: profit (pierdere)	090	73 606	35 002
Profit (pierdere) pînă la impozitare (rd.080 + rd.090)	100	23 260 050	13 076 189
Cheltuieli privind impozitul pe venit	110	3 112 701	1 924 619
Profit net (pierdere netă) al perioadei de gestiune (rd.100 - rd.110)	120	20 147 349	11 151 570

SITUAȚIA MODIFICĂRILOR CAPITALULUI PROPRIU
de la 01 ianuarie pînă la 31 decembrie 2018

Anexa 3

Indicatori	Cod rd.	Sold la începutul perioadei de gestiune	Majorări	Diminuări	Sold la sfîrșitul perioadei de gestiune
2	3	4	5	6	7
Capital social și suplimentar					
Capital social	010	5 400			5 400
Capital suplimentar	020				0
Capital neversat	030	()	()	()	()
Capital neînregistrat	040				
Capital retras	050	()	()	()	()
Total capital social și suplimentar (rd.010 + rd.020 + rd.030 + rd.040 + rd.050)	060	5 400	0	0	5 400
Rezerve					
Capital de rezerva	070	801 621			801 621
Rezerve statutare	080	2 247			2 247
Alte rezerve	090				
Total rezerve (rd.070 + rd.080 + rd.090)	100	803 868	0	0	803 868
Profit nerepartizat (pierdere neacoperită)					
Corecții ale rezultatelor anilor precedenți	110				
Profit nerepartizat (pierdere neacoperită) al anilor precedenți	120	33 964 874			33 964 874
Profit net (pierdere netă) al perioadei de gestiune	130	x	11 151 570	0	11 151 570
Profit utilizat al perioadei de gestiune	140	x	()	()	()
Rezultatul din tranziția la noile reglementări contabile	150				
Total profit nerepartizat (pierdere neacoperită) (rd.110 + rd.120 + rd.130 + rd.140 + rd.150)	160	33 964 874	11 151 570	0	45 116 444
Alte elemente de capital propriu, din care	170				
Diferențe din reevaluare	171				
Subvenții entităților cu proprietate publică	172				
Total capital propriu (rd.060 + rd.100 + rd.160 + rd.170)	180	34 774 142	11 151 570	0	45 925 712