

Endoscope

OPERATION MANUAL

Duodenoscope

ED-580XT

Introduction

1 Precautions

2 Product Overview

3 Workflow

4 Preparation and Inspection

5 How to Use

6 Troubleshooting

7 Service

Appendix

This Operation Manual provides details on how to prepare and operate the endoscope and describes cautions to be observed. Please read this manual thoroughly before operating the endoscope.

After reading this manual, store it nearby the endoscope so that you can review it whenever necessary.



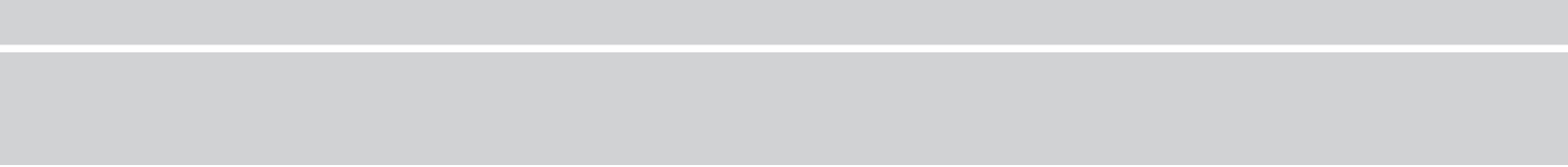

Contents at a Glance

Introduction

This chapter explains about this manual.

Chapter 1 Precautions

Before using this product, read this chapter carefully so that you can operate it correctly. This chapter describes the warnings and cautions for safe operation of the endoscope.

Chapter 2 Product Overview

This chapter describes details on the accessories supplied with this product, the nomenclature and functions of the endoscope, and related equipment connected to this product.

Chapter 3 Workflow

This chapter describes the workflow of endoscopy, which differs depending on the type of endoscope and accessories to be used.

Chapter 4 Preparation and Inspection

This chapter describes the inspection and preparation methods to be performed before using the endoscope, its accessories and related equipment.

Chapter 5 How to Use

This chapter describes the basic operation procedures of this product and precautions to observe.

Chapter 6 Troubleshooting

This chapter describes actions which should be taken if problems or questions occur while inspecting or using the endoscope.

Chapter 7 Service

This chapter explains the services regarding this product.

Appendix

This chapter describes main specifications, related equipment used in combination with this product, electromagnetic compatibility (EMC), etc.

Contents

Contents at a Glance	iii
Introduction	1
About This Manual	1
◆ Endoscope Operation Manuals	2
How to Read This Manual	3
◆ Terms	3
◆ Conventions Used in This Manual	3
Chapter 1 Precautions	1-1
1.1 Intended Use	1-1
1.2 Applicability of Endoscopy and Endoscopic Treatment	1-1
1.3 User Qualifications	1-2
1.4 Prohibition of Modification and Improper Repair	1-2
1.5 Reprocessing Before the First Use/Reprocessing and Storage After Use	1-3
1.5.1 Reprocessing Before the First Use/Reprocessing After Use	1-3
1.5.2 Storage After Use	1-4
1.5.3 Disposal	1-4
1.6 For Safe Operation	1-4
1.7 Maintenance	1-4
1.8 Symbols	1-5
1.9 Precautions for Transportation	1-6
1.10 Precautions Against Electric Shock	1-6
1.11 Electromagnetic Compatibility (EMC)	1-7
1.12 General Warnings and Cautions	1-8
1.12.1 Precautions for Inspection Before Use	1-8
1.12.2 Handling Precautions	1-9
1.12.3 Abnormalities during Use of This Product	1-14
1.12.4 Precautions for Distal Elevator/Recess	1-14
1.13 Precautions for Equipment Used in Combination	1-15
1.13.1 Precautions for High-Frequency Treatment	1-17
1.13.2 Precautions for Endotherapy Device and Syringe	1-18
Chapter 2 Product Overview	2-1
2.1 Checking Package Contents	2-1
2.1.1 Endoscope	2-1
2.1.2 Accessories	2-2
◆ Accessories Common to All Models	2-2

2.2	Nomenclature and Functions of Endoscope.....	2-4
	◆ LG Connector	2-6
	◆ Video Connector.....	2-6
	◆ LG Flexible Portion.....	2-6
	◆ Interconnect Cable	2-6
	◆ Control Portion (G7 control portion)	2-7
	◆ Boot.....	2-8
	◆ Insertion Portion (Applied Part)	2-8
2.3	Nomenclature and Functions of Distal End of Endoscope	2-9
2.4	Location of Each Label	2-10
2.4.1	Location of Labels	2-10
2.5	System Configuration	2-11
Chapter 3	Workflow	3-1
3.1	When Using Standard Functions.....	3-2
Chapter 4	Preparation and Inspection	4-1
4.1	Preparation of the Equipment.....	4-2
	◆ Endoscope	4-2
	◆ Accessories	4-2
	◆ Related Equipment (Essential).....	4-3
	◆ Related Equipment (To be Prepared when Necessary).....	4-3
	◆ Personal Protective Equipment	4-4
	◆ Others.....	4-4
4.2	Transporting Endoscope.....	4-5
4.3	Inspecting Endoscope	4-6
4.3.1	Inspecting Control Portion	4-6
4.3.2	Inspecting Insertion Portion	4-6
4.3.3	Inspecting Distal End.....	4-7
4.3.4	Inspecting Bending Section	4-8
	◆ Inspection for Smooth Operation.....	4-8
	◆ Inspecting Up/Down Angulation	4-9
	◆ Inspecting Left/Right Angulation.....	4-10
4.3.5	Inspecting Forceps Elevator Mechanism.....	4-11
4.3.6	Inspecting LG Connector.....	4-11
4.3.7	Inspecting Video Connector	4-12
4.4	Inspecting and Attaching Accessories	4-13
4.4.1	Forceps Valve.....	4-13
4.4.2	Suction Valve.....	4-14
4.4.3	Air/Water Valve.....	4-16

4.4.4	Distal End Cap.....	4-18
4.5	Preparing Related Equipment.....	4-20
4.5.1	Inspecting Related Equipment.....	4-20
4.5.2	Preparing System.....	4-20
4.6	Connecting Endoscope to Light Source, Processor and Related Equipment.....	4-22
4.6.1	Connecting to Light Source.....	4-22
4.6.2	Connecting to Processor.....	4-23
4.6.3	Attaching Water Tank.....	4-24
4.6.4	Attaching Suction Unit.....	4-25
4.7	Inspecting Functions Used in Combination with Related Equipment.....	4-26
4.7.1	Inspecting Endoscopic Images.....	4-26
4.7.2	Inspecting Scope Switch.....	4-27
4.7.3	Inspecting Air/Water Supply Function.....	4-28
4.7.4	Inspecting Suction Function.....	4-29
Chapter 5 How to Use		5-1
5.1	Preparation.....	5-3
5.1.1	Preparing Related Equipment.....	5-3
5.1.2	Pretreatment of Patient.....	5-3
5.1.3	Preparing Mouthpiece.....	5-3
5.2	Insertion and Observation.....	5-4
5.2.1	Insertion.....	5-4
5.2.2	Observing Endoscopic Image.....	5-6
5.2.3	Operating Scope Switch.....	5-7
5.2.4	Bending Operation.....	5-7
5.2.5	Operating Air/Water Valve.....	5-9
5.2.6	Operating Suction Valve.....	5-10
5.3	Injecting Fluids from Instrument Channel Inlet.....	5-11
5.4	ERCP.....	5-12
5.5	Treatment.....	5-14
5.5.1	Using Endotherapy Devices.....	5-14
5.5.2	Use of Non-Flammable Gases.....	5-16
5.5.3	High-Frequency Treatment.....	5-16
5.6	Endoscope Withdrawal.....	5-18
5.7	Detaching Distal End Cap.....	5-19
5.8	Reprocessing Endoscope.....	5-20
Chapter 6 Troubleshooting		6-1
6.1	Troubleshooting.....	6-2
6.1.1	Problem with Displayed Images.....	6-2

6.1.2	Problem with Scope Switch	6-3
6.1.3	Problem with Bending Section.....	6-3
6.1.4	Problem with Air/Water Supply.....	6-4
6.1.5	Problem with Suction.....	6-4
6.1.6	Problem with Related Equipment.....	6-5
	◆ Problem with Endotherapy Devices	6-5
	◆ Problem with Image Recorder.....	6-6
6.2	Withdrawal of Endoscope with Abnormality.....	6-7
6.2.1	When Endoscopic Images Appear on the Monitor	6-7
6.2.2	When Endoscopic Images Do Not Appear on the Monitor or a Frozen Image Cannot be Restored	6-8
6.3	Handling of Endoscope with Abnormality	6-9
6.3.1	When Suction Valve Does Not Return to Its Original Position	6-9
6.4	Returning Endoscope for Repair	6-11
Chapter 7	Service	7-1
7.1	Service.....	7-1
7.2	After-Sales Service	7-1
	◆ Repairs during the warranty period	7-1
	◆ Repairs after the warranty period	7-1
Appendix	Appendix-1	Appendix-1
	Main Specification.....	Appendix-1
	◆ Classification of Medical Electrical Equipment.....	Appendix-1
	◆ Electromagnetic Compatibility (EMC) Related Standard.....	Appendix-1
	◆ Applied Part.....	Appendix-1
	◆ Specifications	Appendix-2
	Operating Environment, Transport Environment and Storage Environment.....	Appendix-3
	◆ Operating Environment	Appendix-3
	◆ Transport Environment.....	Appendix-3
	◆ Storage Environment.....	Appendix-3
	◆ Term of Validity/Period for Use (Durability).....	Appendix-3
	Accessories.....	Appendix-4
	Related Equipment Used in Combination	Appendix-5
	◆ Compatible Processor and Light Source.....	Appendix-5
	◆ Water Tank.....	Appendix-5
	◆ Suction Unit	Appendix-5
	◆ Endoscopic CO2 Regulator and Accessories	Appendix-5
	◆ Electrosurgical Unit	Appendix-6
	◆ Air Leak Tester	Appendix-6

◆ Mouthpiece	Appendix-6
◆ Compatible Endotherapy Devices	Appendix-6
Electromagnetic Compatibility (EMC) Information	Appendix-7
Disposal of Electric and Electronic Equipment	Appendix-11
Index	Appendix-12

Introduction

This chapter explains about this manual.

About This Manual

This manual provides necessary information for using this product, such as the equipment overview, operation procedures and precautions to observe. In addition, the Reprocessing Manual supplied with this product describes the reprocessing and storage methods for the endoscope. This manual does not provide information about procedures or any aspects of endoscopic techniques.

Before using this product, thoroughly read and understand this manual, the Reprocessing Manual and the manual of related equipment and use this product as instructed.

Also, after reading this manual, store it close to this product for future reference to keep this product in optimum working condition.

If you have any questions or comments about any information in this manual, contact your local FUJIFILM dealer.

This manual may not be reproduced in whole or in part in any form without prior permission.
The information contained in this manual may be subject to change without prior notice.

Trademarks

The company names and product names described in this manual are trademarks or registered trademarks of FUJIFILM Corporation or its subsidiaries.

Other holders' trademarks

All other company names and product names described in this manual are trademarks or registered trademarks of their respective owners.

Copyright © 2018 FUJIFILM Corporation. All rights reserved.

◆ Endoscope Operation Manuals

Manage and store “Operation Manual” and “Reprocessing Manual” together as a set.

Endoscope Operation Manual

Model: ED-580XT

⇒ This manual provides necessary information for using the endoscope such as the equipment overview, operation procedures and precautions to observe.

Endoscope Reprocessing Manual

Model: ED-580XT

⇒ This manual describes the reprocessing and storage methods of the endoscope.

Note In this manual, the Endoscope Operation Manual is referred to as “this manual”, and the Endoscope Reprocessing Manual as “the Reprocessing Manual.”

How to Read This Manual

◆ Terms

Term	Description
Reprocessing	It refers to disinfection or sterilization performed after the manual cleaning of the endoscope and its accessories according to the Reprocessing Manual supplied with this product.
This product	It refers to the endoscope with or without attached accessories.
Standard accessory	It refers to the parts and devices included in the package or supplied with this product.
Accessory	It refers to the parts and devices directly attached to or used with the endoscope.
Related equipment	It refers to the devices directly or indirectly connected to or used with this product during a procedure.
Consumable item	It refers to parts and products whose life expectancy is limited and which require replacement once they show signs of wear or irregularity. Such parts and products cannot be repaired or refurbished and should be replaced after any irregularity (described in "Section 4.4 Inspecting and Attaching Accessories") is observed.

◆ Conventions Used in This Manual

This manual uses the following conventions for easier understanding.

Convention	Description
WARNING	Explains dangerous situations that may cause death or serious injury if not avoided.
CAUTION	Explains situations that may cause injury if not avoided. Explains situations that may cause damage to equipment if not avoided.
(1), (2), (3), ...	Indicates consecutive numbers in operating procedures for the order in which successive steps in the procedure should be taken.
Note	Indicates a comment or supplementary information.
→	Indicates a reference.

Chapter 1 Precautions

Before using this product, read this chapter carefully so that you can operate it correctly. This chapter describes the warnings and cautions for safe operation of the endoscope.

1.1 Intended Use

FUJIFILM Endoscope Model ED-580XT is intended for the observation, diagnosis and endoscopic treatment of the esophagus, stomach and duodenum at medical facilities under the management of physicians.

Never use this product for any other purposes.

WARNING

- Never use this product for any other purposes. It may cause severe harm to patient and/or end-users.

1.2 Applicability of Endoscopy and Endoscopic Treatment

Proper clinical judgment should be exercised for the applicability of endoscopy and endoscopic treatment. If there are official standards on the applicability of endoscopy and endoscopic treatment that are defined by the hospital's administrators or other official institutions, such as academic societies on endoscopy, follow those standards.

Perform endoscopy and endoscopic treatment only when the benefits outweigh the risks.

1.3 User Qualifications

WARNING

- The healthcare facilities owning this product are responsible for the use and maintenance of this product. If this product is not used or maintained properly, it may cause severe harm to patient or end-users.
- This product is intended for use by medical professionals who have received proper training in endoscopic procedures. This manual does not provide information about procedures or any aspects of endoscopic techniques. Not following the recommendations may cause severe harm to patient or end-users.

If there are official standards for user qualifications for performing endoscopy and endoscopic treatment that are defined by the hospital's medical administrators or other official institutions such as academic societies on endoscopy, follow those standards.

The physician should be capable of safely performing the planned endoscopy and endoscopic treatment following guidelines set by the academic societies on endoscopy, etc., and considering the difficulty of endoscopy and endoscopic treatment.

1.4 Prohibition of Modification and Improper Repair

Do not modify this product or its components, and do not disassemble, repair or in any other way reverse-engineer these products. Even if you find a defect, do not attempt to repair these products yourself. FUJIFILM Corporation shall not be liable for any defects, adverse events or device failures caused by such modifications, disassembly, repairs or reverse-engineering.

FUJIFILM Corporation shall not be liable for malfunctions, adverse events or damages caused by remodeling, maintenance, and repair using repair parts other than those authorized by FUJIFILM Corporation.

FUJIFILM Corporation shall not be liable for malfunctions, adverse events or damages caused by installation, relocation, remodeling, maintenance, and repair not performed by FUJIFILM Corporation or by dealers authorized by FUJIFILM Corporation.

WARNING

- Do not disassemble or modify this product. Do not perform unauthorized repairs. If any disassembly, modification or improper repair is performed, it may cause severe harm to patient or end-users.

CAUTION

- Do not disassemble or modify this product. Do not perform unauthorized repairs. If any disassembly, modification or improper repair is performed, it may cause equipment failure.

1.5 Reprocessing Before the First Use/Reprocessing and Storage After Use

1.5.1 Reprocessing Before the First Use/Reprocessing After Use

This product has not been reprocessed. The endoscope and its accessories must be reprocessed prior to first use as per instructions provided in the Reprocessing Manual.

After using the endoscope and its accessories, reprocess and store them according to the instructions provided in the Reprocessing Manual.

Note Delayed reprocessing of endoscopes, particularly duodenoscopes, is not recommended.

WARNING

- The entire surface and each channel of the endoscope and the accessories must be reprocessed prior to first use, after any servicing, after any subsequent use, and after storage as per instructions provided in the Reprocessing Manual, even if the accessories were not used during a procedure. In addition, store this product as per instructions provided in the Reprocessing Manual. Inadequate reprocessing or storage may cause infection.
- When using this product for a patient with Creutzfeldt-Jakob disease (especially variant Creutzfeldt-Jakob disease), use it exclusively for a patient with the same disease, or properly discard this product after use. Since the cleaning, disinfection and sterilization methods described in the Reprocessing Manual of this product cannot eliminate the causal agents of Creutzfeldt-Jakob disease, the product could be a source of infection. For the treatment of Creutzfeldt-Jakob disease, refer to local guidelines.
- Immediately upon completion of the procedure, it is imperative that pre-cleaning is performed as per instructions provided in the Reprocessing Manual. Otherwise, residual organic debris may begin to dry and solidify and hinder effective removal and reprocessing, causing infection.

CAUTION

- The entire surface and each channel of the endoscope and the accessories must be reprocessed prior to first use, after any servicing, after any subsequent use, and after storage as per instructions provided in the Reprocessing Manual. In addition, store this product as per instructions provided in the Reprocessing Manual. Inadequate reprocessing or storage may cause equipment damage, or reduce performance.
- Do not forcibly twist or bend the insertion tube of the endoscope. It could damage the endoscope.

1.5.2 Storage After Use

Store this product after reprocessing. For details on the reprocessing and storage of the endoscope, refer to the Reprocessing Manual.

1.5.3 Disposal

For details on the disposal of the endoscope and accessories, refer to the Reprocessing Manual.

1.6 For Safe Operation

Be sure to prepare a spare endoscope for unexpected events such as the failure of this product. Otherwise, you may not be able to continue the endoscopic procedure. If the spare endoscope is not available, prepare other alternative means such as abdominal surgery.

- Note**
- It is highly recommended that spare or back-up equipment be available to complete procedures due to unforeseen circumstances including but not limited to interruption or loss of a clear endoscopic image, equipment failure, etc.
 - If an endoscopic image is lost or compromised during a therapeutic procedure, immediately stop treatment and withdraw the endotherapy device together with the endoscope. Use back-up equipment to complete the procedure as necessary.

1.7 Maintenance

WARNING

- Deterioration or degradation of the endoscope components or its accessories may occur due to factors such as long-term use, procedures, routine handling and repeated reprocessing. Have this product checked by service personnel once every six months or once every 100 cases, whichever comes first. Use of nonfunctional equipment may cause severe harm to patient or end-users.















This product should not be subjected to any type of repair or maintenance procedure while it is being clinically used on a patient (or while it is being reprocessed).

The more the product is used, the greater the probability of failure of the endoscope and its accessories. Do not use the endoscope that shows any sign of abnormality or irregularity. Take appropriate measures by following “Chapter 6 Troubleshooting.” If the irregularity is still observed after inspection, contact your local FUJIFILM dealer.

- Note**
- This duodenoscope must be returned to a FUJIFILM service facility at least on an annual basis to replace its distal elevator o-ring.

1.8 Symbols

This section explains the safety signs used in this product.

Symbol	Description
	Do not re-use / Single patient use only
	Lot number
	Serial number
	Year of manufacture
	Manufacturer
	Authorized representative in the European Community
	Temperature limitation
	Keep dry
	Non-sterile
	CE marking
	Type BF applied part
	WEEE marking *
	Humidity limitation
	Atmospheric pressure limitation
	Minimum diameter of the instrument channel: 4.2 mm

* This product shall not be treated as household waste.

1.9 Precautions for Transportation

WARNING

- Carry a reprocessed endoscope in a clean manner. If personal protective equipment such as gloves is contaminated, the contaminants adhere to the endoscope and it can be a source of infection.
- Contact your local FUJIFILM dealer when this product is returned for repair. Be sure to reprocess this product before returning for repair. If a product which is not reprocessed is returned, it can create a risk of infection to users, service personnel or other persons in contact with it.

CAUTION

- When transporting a reprocessed endoscope, firmly grasp the control portion and LG connector. If only the LG flexible portion or the boot is grasped, it may damage the endoscope.
- When transporting a reprocessed endoscope, do not coil the insertion tube or the LG flexible portion of the endoscope with a small diameter. Doing so may cause endoscope failure.
- When transporting the endoscope to the outside of the hospital, store the endoscope in a FUJIFILM-specified carrying case. Not doing so may cause product failure.

1.10 Precautions Against Electric Shock

WARNING

- Connect the power plug of related equipment to be used to the protective earth receptacle. Not doing so may cause an electric shock.

CAUTION

- Do not use related equipment which is not described in this manual. If the endoscope is used in combination with endoscopic accessories connected to other medical devices, it may cause an electric shock due to an increase in patient leakage current.

1.11 Electromagnetic Compatibility (EMC)

This product generates, uses and can radiate radio frequency energy. To prevent electromagnetic interference within the vicinity of this product, read the following precautions and properly handle this product and other devices in the vicinity.

WARNING

- Do not place any objects that emit strong electromagnetic waves near this product. Otherwise, malfunction of this product may occur.

CAUTION

- Noise may appear on the monitor of this product due to the effect of electromagnetic interference. In this case, turn off the device emitting the electromagnetic waves or move the device away from the monitor.

This product may receive electromagnetic interference even if related equipment conforming to EN 55011 is used.

Use of this product may cause electromagnetic interference. Depending upon the strength of electromagnetic interference within the vicinity of this product, malfunction of this product or peripherals may occur. If this product does cause harmful electromagnetic interference to other devices, or if this product receives electromagnetic interference from other devices, we recommend that you may try to correct the interference by one or more of the following measures:

- Change the orientation or position of any affected device.
- Increase the spacing between devices.
- Connect the product into an outlet on a circuit different from that to which the other device(s) are connected.
- Take mitigation measures such as shielding the installation location of any affected device.

If the problem cannot be solved with the above measures, stop using this product and consult the manufacturer or your local FUJIFILM dealer for help.

Electromagnetic interference may occur in the vicinity of equipment marked with the following symbol or other portable and mobile RF (radio frequency) communications equipment, such as cellular phones.



1.12 General Warnings and Cautions

Observe the following cautions when handling this product. Also, there are same cautions in each chapter.

1.12.1 Precautions for Inspection Before Use

WARNING

- Make sure to inspect the endoscope and accessories before use according to the procedures provided in this manual. Do not use the equipment that shows any signs of abnormality or irregularity. Use of abnormal equipment may lead to misdiagnosis or increase risks to patient safety.
- Make sure to check the forceps valve before use. If the inspection result shows any sign of abnormality or irregularity, replace the forceps valve with a new one already reprocessed. Use of an abnormal forceps valve may cause the leakage of body fluid, posing an infection risk.
- Make sure to check the distal end cap before use. If the inspection result shows any sign of abnormality or irregularity, replace the distal end cap with a new one already reprocessed. Use of an abnormal distal end cap can pose a risk of infection.
- Turn the up/down and left/right angulation knobs slowly in each direction until they stop. Repeat this operation several times to confirm that the bending section angulates smoothly and correctly. If the endoscope with an abnormal angulation knob is used, the bending section does not return to its neutral position, causing patient injury.
- If water leaks from the forceps valve or suction valve during the inspection of the suction function, replace it with a new one already reprocessed. A leaking forceps valve or suction valve may cause backflow of body fluid, posing an infection control risk.
- If water leaks from the air/water valve during the inspection of the air/water supply function, replace it with a new one already reprocessed. A leaking air/water valve may cause backflow of body fluid, posing an infection control risk.
- Turn off the light of the light source before inspecting the objective lens. Viewing the light from the light guide directly may damage your eyes.

CAUTION

- Make sure to inspect the endoscope and accessories before use according to the procedures provided in this manual. Do not use the equipment that shows any signs of abnormality or irregularity. Use of abnormal equipment may cause equipment malfunction.
- Do not forcibly turn the angulation knob further after turning the knob until it stops. If the angulation knob is forcibly turned, it may cause malfunction of the endoscope.
- Make sure that no moisture or foreign matter (such as dust, gauze fibers, metallic fragments) adheres to the LG connector before connecting it to the light source. If the LG connector with moisture or foreign matter (such as dust, gauze fibers, metallic fragments) is connected, it may cause malfunction or failure of the devices.

CAUTION

- Do not touch the light guide cover glass. A dirty light guide cover glass may result in the reduction of light intensity.
- If abnormalities and/or material changes including but not limited to cracking, flaking, pitting, corrosion, etc. which can create sharp edges, compromise sealed surfaces and/or negatively affect device functionality are found, contact your local FUJIFILM dealer.

1.12.2 Handling Precautions

WARNING

- Wear personal protective equipment (such as goggles, facemask, chemical-resistant and waterproof gloves, antifouling protective clothing, cap and shoe covers) during a procedure as well as during reprocessing to protect your eye and skin and to prevent infection. Not doing so may cause infection.
- If you encounter any resistance during a procedure, insert the endoscope slowly. Do not force it in. Do not insert or bend the endoscope without securing the view on the monitor. Not following the recommendations above may cause injury to tissues in the body cavity, bleeding or perforation.
- The forceps valve is intended for single use. Discard it after use. If a deteriorated forceps valve is used, body fluids may leak, causing infection.
- Reprocess the forceps valve before use. Use of an improperly reprocessed forceps valve can create a risk of infection.
- Use a reprocessed forceps valve, air/water valve, suction valve, mouthpiece and distal end cap. Insufficient reprocessing could be a source of infection.
- Ensure that the forceps valve is properly attached to the instrument channel inlet. If this product is used without the forceps valve attached, body fluid may leak and it could be a source of infection.
- The lid of the forceps valve must be closed when using the endoscope. Not doing so may cause leak of body fluids and increase a risk of infection.
- When the lid of the forceps valve needs to be opened during a procedure, place a piece of gauze, etc. over it to prevent leakage. Otherwise, body fluids may leak or splash from the forceps valve, posing an infection control risk to the patient or end-user.
- The distal end cap is intended for single use. Discard it after use. Use of a deteriorated distal end cap can pose a risk of infection.
- Reprocess the distal end cap before use. Use of an improperly reprocessed distal end cap can pose a risk of infection.
- Make sure to check the distal end cap before use. If the inspection result shows any sign of abnormality or irregularity, replace the distal end cap with a new one already reprocessed. Use of an abnormal distal end cap can pose a risk of infection.
- Attach the distal end cap before inserting the endoscope. Not doing so may cause injury to tissues in the body cavity, bleeding and/or perforation.

WARNING

- During an inspection or procedure, use sterile water. If sterile water is not used, it can create a risk of infection.
- Do not quickly release one's finger from the suction valve during aspiration. Doing so may cause a splattering of body fluids from the suction valve and increase a risk of infection.
- Do not supply an excessive amount of air or gas during a procedure. Doing so may cause patient pain, injury to tissues in the body cavity, bleeding, perforation and/or embolism.
- Never use endotherapy devices, operate, insert or withdraw the endoscope, perform bending, air supply or suction, or operate the related equipment while viewing an enlarged endoscopic image on the monitor. Otherwise, injury to tissues in the body cavity, bleeding and/or perforation may result.
- Never use endotherapy devices, operate, insert or withdraw the endoscope, or operate the related equipment without viewing or while freezing the endoscopic image on the monitor. Otherwise, injury to tissues in the body cavity, bleeding and/or perforation may result.
- Do not use endotherapy devices, operate, insert or withdraw the endoscope, perform bending, air supply or suction, or operate the related equipment whenever the endoscopic image is compromised, unclear, blurry, etc. due to any reason or condition including loss of image, power interruption, water droplets or dirt/debris adhering to the objective lens, etc. Doing so may cause injury to tissues in the body cavity, bleeding and/or perforation.
- If a patient sneezes or moves abruptly during the procedure, malfunction of the endoscope and patient bleeding or trauma may occur. Depending on the degree of malfunction, safe endoscope withdrawal may be difficult or impossible, causing severe harm to patient and/or end-users.
- Do not perform retroflexed observation forcibly. Performing retroflexed observation in a narrow lumen may make it impossible to straighten the angle of the bending section and/or withdraw the endoscope from the patient.
- When this product is used for a patient with an active implantable medical device such as a pacemaker, consult a cardiovascular specialist and the manufacturer of the active implantable medical device to ensure patient safety. The radio waves radiated from this product may cause medical devices such as a pacemaker to malfunction or break down, seriously affecting patient safety.
- Do not look directly into the light coming from the light guide at the distal end of the endoscope. Viewing the light from the light guide directly may damage your eyes.
- Do not apply excessive force of the endoscope or endotherapy device against mucosal surfaces. Doing so may cause injury to tissues in the body cavity, bleeding and/or perforation.
- Do not bend or insert the endoscope while an endotherapy device protrudes from the distal end. Excessive force of the endotherapy device may be unintentionally applied against mucosal surfaces, causing injury to tissues in the body cavity, bleeding and/or perforation.
- Use the air/water channel cleaning adapter only for pre-cleaning of the air/water channel. If it is used during a procedure, continuous air supply may occur and cause patient injury.

WARNING

- Do not forcibly advance or withdraw the endoscope into/from the patient, angulate the bending section forcibly or operate it quickly. It may cause patient injury, bleeding or perforation.
- Insert the endoscope while observing the endoscopic image to secure patient safety. Not doing so may cause patient pain, injury, bleeding and/or perforation.
- Do not forcibly turn the angulation knob further after turning the knob until it stops. If the angulation knob is forcibly turned, the angulation mechanism may malfunction and the bending section may not return to its neutral position, making it difficult to withdraw the endoscope.
- If the bending section does not return to its neutral position during a procedure, do not withdraw the endoscope forcibly. Consult your local FUJIFILM dealer. If the endoscope is withdrawn forcibly, injury to tissues in the body cavity, bleeding and/or perforation may result.
- Be extremely careful when performing retroflexed observation in a narrow lumen. Do not perform retroflexed observation forcibly. Otherwise, it may become impossible to straighten the angle of the bending section and/or withdraw the endoscope from the patient.
- Avoid aspirating solid materials or thick fluids. If the suction valve does not return to its original position, stop aspiration immediately and slowly withdraw the endoscope. If any solid materials or thick fluids adhere to or clog the suction valve, suction may not stop, causing damage to mucous membrane.
- When injecting fluids by attaching a syringe to the forceps valve, open the lid of the forceps valve and insert the syringe straight into the forceps valve. Otherwise, the forceps valve may be damaged or the syringe may be accidentally detached during fluid injection and body fluids may leak or splash from the forceps valve, posing an infection control risk to the patient or end-user.
- Do not strongly press the endotherapy device against tissues in the body cavity. Otherwise, injury to tissues in the body cavity, bleeding and/or perforation may result.
- Unless the endoscope's bending section is in a neutral position (essentially "straight"), do not withdraw the endoscope whenever the endoscopic image is compromised, unclear, blurry, etc. due to any reason or condition including loss of image, power interruption, water droplets or dirt/debris adhering to the objective lens, etc. Doing so may cause injury to tissues in the body cavity, bleeding and/or perforation.
- Firmly connect the LG connector of the endoscope and the light source as well as the video connector and the processor. If the LG connector is not connected properly, the endoscopic image may flicker or be lost, which may cause patient injury, bleeding and/or perforation.
- Firmly connect the video connector of the endoscope and the processor. If the video connector is not connected properly, the endoscopic image may flicker or be lost, which may cause patient injury, bleeding and/or perforation.

CAUTION

- Do not use this product outside the operating environment specified in “Main Specification.” Otherwise, it can cause product malfunction or failure.
- Do not apply unnatural force or impact on the insertion portion, bending section, control portion, LG flexible portion, LG connector or video connector. Doing so may cause malfunction of the endoscope.
- When holding the endoscope, hold it by the control portion. Handling it up by the insertion portion or LG flexible portion is difficult to hold and may exert an unnatural force, resulting in instrument failure.
- During an observation, do not perform close observation for an extended period of time. Use the endoscope with a minimum necessary amount of brightness and time while maintaining an appropriate distance. Thermal energy created by illumination may cause burn injury.
- Immediately after detaching the LG connector from the light source, do not touch the light guide prong with hands since it may be extremely hot. There is a risk of burn injury.
- If the brightness level of the light source or processor is high, the surface temperature at and around the distal end of the endoscope may exceed 41°C. Do not allow the distal end to remain in contact with the same site for an extended period of time. It may cause burn injury.
- Do not use a mouthpiece that is damaged, deformed, or reveals other irregularities. Doing so may cause injury in the oral cavity and/or equipment failure.
- Do not directly apply Xylocaine spray to the insertion portion. Do not use olive oil as a lubricant for insertion. It may cause deterioration of the outer surface.
- Avoid forcible or excessive angulation as this may impose a severely heavy load on the wire controlling the bending section. This may cause stretching or tearing of the wire.
- The lid of the forceps valve must be closed when using the endoscope. Not doing so can reduce the efficacy of the endoscope’s suction system, making it impossible to perform aspiration.
- Do not hold the bending portion tightly when attaching or detaching the distal end cap. There is a risk of damaging the endoscope.
- Securely attach the distal end cap to the distal end of the endoscope before use. If the distal end cap is not attached securely, the distal end cap may fall off during use.
- Use this product in combination with the distal end cap DC-07D. If another type of distal end cap is used in combination with this product, the distal end cap may fall off during use.
- If the distal end cap becomes misaligned or falls off during a procedure, stop the procedure immediately and slowly withdraw the endoscope. Otherwise, it may cause injury to tissues in the body cavity.
- Insert the endotherapy device slowly. The endotherapy device may bend if it is inserted quickly.
- When inserting an endotherapy device, close the lid of the forceps valve. If the lid is open, it can reduce the efficacy of the endoscope’s suction system, making it impossible to perform aspiration.

CAUTION

- When attaching the suction valve to the suction valve cylinder of the endoscope, align the recessed and projecting portions and slowly insert the suction valve straight into the suction valve cylinder of the endoscope. If the suction valve is attached forcibly, it may be damaged.
- Do not use any lubricants (except sterile water) to the air/water valve. It may impair the functionality of the valve or may clog the channel, diminishing functionality of air/water supply.
- Slowly insert the air/water valve straight into the air/water valve cylinder of the endoscope. If the air/water valve is attached forcibly, it may be damaged.
- Firmly connect the LG connector of the endoscope and the light source. Do not look into the connecting part between the endoscope and the light source. Light leaking from the connecting part may cause damage to the eyes.
- If you encounter any resistance during a procedure, insert the endoscope slowly. Do not force it in. Do not insert or bend the endoscope without securing the view on the monitor. Not following the recommendations above may cause endoscope failure or patient injury.
- When the shutter speed is set to "HIGH", take care not to set the brightness level too high. Thermal energy created by illumination may cause burn injury.
- Do not push the boot of the control portion against the bed, etc. during a procedure. Doing so may cause endoscope failure.

1.12.3 Abnormalities during Use of This Product

WARNING

- If any abnormality occurs during use, carry out safety checks such as checking the patient's condition and discontinue use immediately. Not doing so may seriously affect patient safety.
- If an abnormality occurs during a treatment, stop the treatment immediately and slowly pull out the endotherapy device from the endoscope. If the endotherapy device cannot be pulled out from the endoscope, withdraw the tip of the endotherapy device to the instrument channel outlet of the endoscope, and then slowly pull out the endoscope and endotherapy device together. If the treatment is not stopped or the endotherapy device is forcibly pulled out, it may cause injury to tissues in the patient's body cavity, bleeding and/or perforation.
- During a procedure, if any abnormality (loss of image, dark image, bright image, etc.) is found in the endoscopic image, the imaging section may malfunction. If this happens, stop the treatment immediately and slowly pull out the endoscope. If the endoscope is used as it is, it may cause overheating of the distal end, possibly resulting in mucosal burns or other injury.
- If it is necessary to supply air or water from the suction connector when an abnormality is found in the suction valve during a procedure, do so while pressing the suction valve. If air or water is supplied without pressing the suction valve, body fluids may leak or splash from the suction valve, posing an infection control risk.

Note If any abnormality occurs with this product, refer to "Chapter 6 Troubleshooting." Should any safety concerns arise with this product, contact your local FUJIFILM dealer.

1.12.4 Precautions for Distal Elevator/Recess

CAUTION

- Lower the forceps elevator before inserting or withdrawing the endoscope. Not doing so may cause patient injury.

1.13 Precautions for Equipment Used in Combination

Use this product in combination with related equipment described in this manual.

→ “Appendix - Related Equipment Used in Combination”

Using related equipment not described in this manual can result in not only abnormal operations but also equipment damage and/or patient or end-user injury.

This instrument complies with the EMC standard for medical electrical equipment, Edition 3 (EN 60601-1-2:2007). However, when connected with an instrument that complies with the EMC standard for medical electrical equipment, Edition 1 (EN 60601-1-2:1993), the whole system complies with Edition 1.

In addition, when connected with an instrument that complies with the EMC standard for medical electrical equipment, Edition 2 (EN 60601-1-2:2001), the whole system complies with Edition 2. For details, see “Electromagnetic Compatibility (EMC) Information” in Appendix.

→ “Appendix - Electromagnetic Compatibility (EMC) Information”

WARNING

- Use this product only in combination with related equipment described in this manual. Otherwise, it is unable to ensure its functionality, and may cause severe harm to patient or end-users.
- Set the suction pressure between 40 and 53 kPa. If the suction pressure is too high, patient debris or fluids may leak or splash from the forceps valve, posing infection control risks to patient or operator.
- Wear protective clothing when detaching the distal end cap from the distal end of the endoscope. Otherwise, it may pose an infection risk.
- Firmly connect the suction tube from the suction unit to the suction connector on the LG connector. If the suction tube is not attached properly, body fluid may drip from the tube and can pose an infection control risk.

CAUTION

- Turn off the light of the light source except during an inspection, procedure, etc., when necessary. If the light of the light source is left on, the distal end of the endoscope and its surroundings may become hot, causing burn injury to the patient or end-user.
- When turning off the processor, also turn off the light source. If the light source remains on after turning off the processor, the ALC (automatic light control) does not function and the maximum amount of light is emitted. As a result, the distal end of the endoscope and its surroundings may become hot, causing burn injury to the patient or end-user.

CAUTION

- Use this product only in combination with related equipment described in this manual. Otherwise, it creates a risk of equipment malfunction.
- Use the endoscopic CO₂ regulator described in this manual. If another insufflation device is connected, the air/water supply function lessens and may result in improper cleaning of the lens.
- Set the suction pressure between 40 and 53 kPa. If the suction pressure is too high, the endoscope may adhere to mucous membrane, resulting in damage to the mucous membrane.
- Do not grasp the bending section forcefully when attaching or detaching the distal end cap. It may cause malfunction of the endoscope.
- Do not subject the video connector or the LG connector to strong impact. Install the processor and the light source away from obstacles to prevent the video connector connected to the processor and the LG connector connected to the light source from accidental impact damage. During the operation of an electric bed, etc., ensure that the video connector connected to the processor or the LG connector connected to the light source does not hit the bed. Otherwise, the endoscope's video connector and LG connector, processor and light source may malfunction.
- With regard to the amount of sterile water in the water tank, follow the instructions provided in the operation manual of the water tank. If the amount of sterile water in the water tank exceeds the limit, the air/water supply function may be disabled or it may cause equipment failure due to contact with leaked sterile water.
- Attach the water tank to the specified position of the cart or light source. Otherwise, fluid may leak from the connector of the water tank and it may come into contact with related equipment, causing equipment failure.
- Firmly connect the suction tube from the suction unit to the suction connector on the LG connector. If the suction tube is not attached properly, body fluid may drip from the tube and come into contact with related equipment, causing equipment failure.

- Note**
- For details on how to use related equipment, refer to the operation manual of related equipment.
 - Before using this product, thoroughly read the operation manual of related equipment used in combination with this product.

1.13.1 Precautions for High-Frequency Treatment

WARNING

- Set the minimum required output power of the electrosurgical unit and high-frequency endotherapy device within the specified output range as per instructions provided in the operation manual of the electrosurgical unit and high-frequency endotherapy device. If the output power is inappropriate, it may cause injury to tissues in the body cavity, thermal injury, bleeding or perforation.
- If the intestines contain a flammable gas, replace it with air or a non-flammable gas such as air or CO₂ before performing high-frequency treatment. Performing high-frequency treatment while the intestines are filled with a flammable gas could result in an explosion and/or fire.
- Wear chemical-resistant and waterproof gloves when performing high-frequency treatment. If not worn, there is a risk of thermal injury or electric shock.
- Always keep pacemaker users away from the electrosurgical unit. The pacemaker may malfunction.
- When performing high-frequency treatment, maintain enough distance between the distal end of endoscope and the tip of the electrosurgical unit. Energize the electrosurgical unit after bringing the tip of the endotherapy device into the field of view. When the high-frequency endotherapy device or energizing part makes contact with the distal end of the endoscope, do not energize the electrosurgical unit. When performing high-frequency treatment, suck mucus adhering to the tissues in the body cavity first and then energize the electrosurgical unit. If the unit is energized when the endotherapy device in contact with the distal end of the endoscope or mucus, it may cause thermal injury.
- Before performing high-frequency treatment, basic in vitro experiments must be performed sufficiently by the user to acquire the skills necessary for high-frequency treatment.
- Use an electrosurgical unit conforming to EN 60601-2-2 (IEC 60601-2-2). If any other electrosurgical unit is used, it may cause severe harm to patient and/or end-users.
- Use the electrosurgical unit and related endotherapy devices per instructions provided in the operation manual for each respective device. Otherwise, device failure, electric shock and/or burns may occur.
- This product is not intended for use with the laser cauterization system. Do not use this product in combination with the laser cauterization system.

CAUTION

- Prevent patient's body from touching electric conductor such as metal part of bed while performing high-frequency treatment. It could cause thermal injury to a patient due to energization via the conductive part.
- When performing high-frequency treatment, take care that patient's vomitus or body fluids do not make contact with the conductive parts such as a metal part of the bed. It could cause thermal injury to a patient due to energization via vomitus or body fluids.
- While performing high-frequency treatment, ensure that the end-user does not touch the patient. It could cause thermal injury to a patient and/or end-user.
- Operate the electrosurgical unit within specified output range as per instructions provided in the operation manual of the electrosurgical unit. Leakage current may cause thermal injury.
- Do not energize the electrosurgical unit when the high-frequency endotherapy device or electrically active portion is in contact with the distal end of endoscope. Thermal injury to a patient or endoscope failure may occur.
- Do not apply the current under the circumstance that patient's clothing is wet when performing high-frequency treatment. Doing so may cause thermal injury.

1.13.2 Precautions for Endotherapy Device and Syringe**WARNING**

- When inserting an endotherapy device into the endoscope, or when injecting fluids by attaching a syringe to the instrument channel inlet, slowly insert the endotherapy device or syringe straight into the endoscope. Also, when withdrawing it, slowly pull straight out. If an endotherapy device or syringe is inserted or withdrawn quickly, or if it is inserted or withdrawn obliquely against the forceps valve, the forceps valve may be damaged or accidentally detached, or a clearance may be generated between the lid and the main body of the forceps valve. As a result, body fluid may be splattered around leading to infection to the patient or end-user.
- Do not perform a procedure with an endotherapy device hung over the forceps valve. Doing so may cause leakage of body fluids and increase a risk of infection.
- Use sterile or reprocessed endotherapy devices. Non-sterile or inadequately reprocessed endotherapy devices may pose an infection risk.

CAUTION

- If resistance is encountered while advancing an endotherapy device within the instrument channel, do not forcibly advance the endotherapy device. Otherwise, it may cause malfunction of the endoscope.

Chapter 2 Product Overview

This chapter describes details on the accessories supplied with this product, the nomenclature and functions of the endoscope, and related equipment connected to this product.

2.1 Checking Package Contents

Check the endoscope and other components in the package against the items shown in the figures below. Inspect the endoscope and each component for damage. If the endoscope or a component is damaged, or if a component is missing, contact your local FUJIFILM dealer.

2.1.1 Endoscope



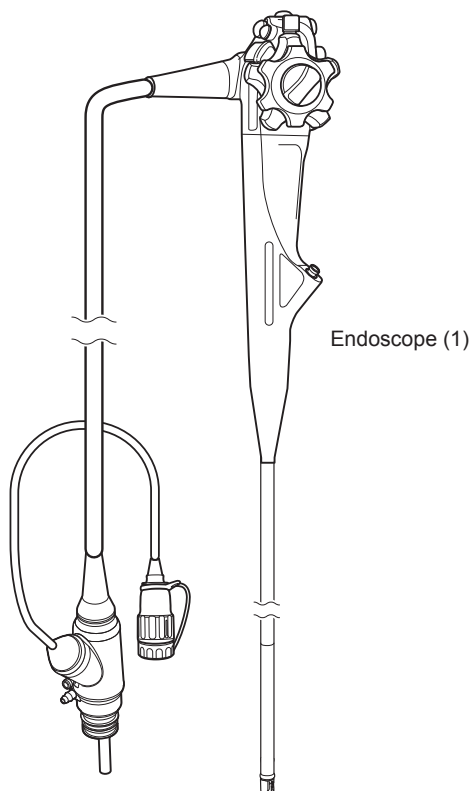



Note Figures in parentheses indicate the number of articles.

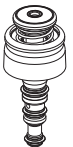

2.1.2 Accessories

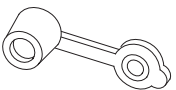
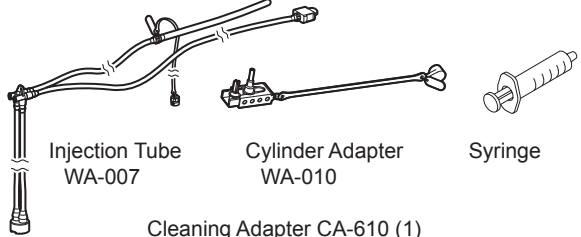
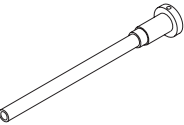
Note Figures in parentheses indicate the number of articles.

◆ Accessories Common to All Models

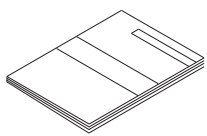
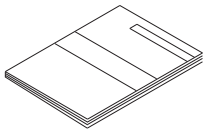
 <p>Suction Valve *1 SB-605 (1)</p>	 <p>Air/Water Valve *1 AW-603 (1)</p>	 <p>Air/Water Channel Cleaning Adapter CA-611 (1)</p>	 <p>Forceps Valve *1 FOV-DV7 (11)</p>	
 <p>Injection Tube WA-007 Cylinder Adapter WA-010 Syringe</p> <p>Cleaning Adapter CA-610 (1)</p>			 <p>Ventilation Adapter AD-7 (1)</p>	 <p>Cylinder/Inlet brush WB11003DV (3)</p>
 <p>Suction Channel Brush WB7025DC (3)</p>	 <p>Distal End Brush WB1318DE (3)</p>	 <p>Distal End Cap *1 DC-07D (11)</p>	 <p>Operation Manual (1)</p>	
 <p>Reprocessing Manual (1)</p>				

*1 This accessory is attached to the endoscope at the time of shipment.

<Carrying Case>

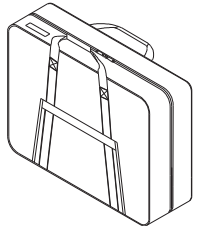
 <p>Carrying Case</p>			
--	--	--	--

2.2 Nomenclature and Functions of Endoscope

This product consists of the following parts.

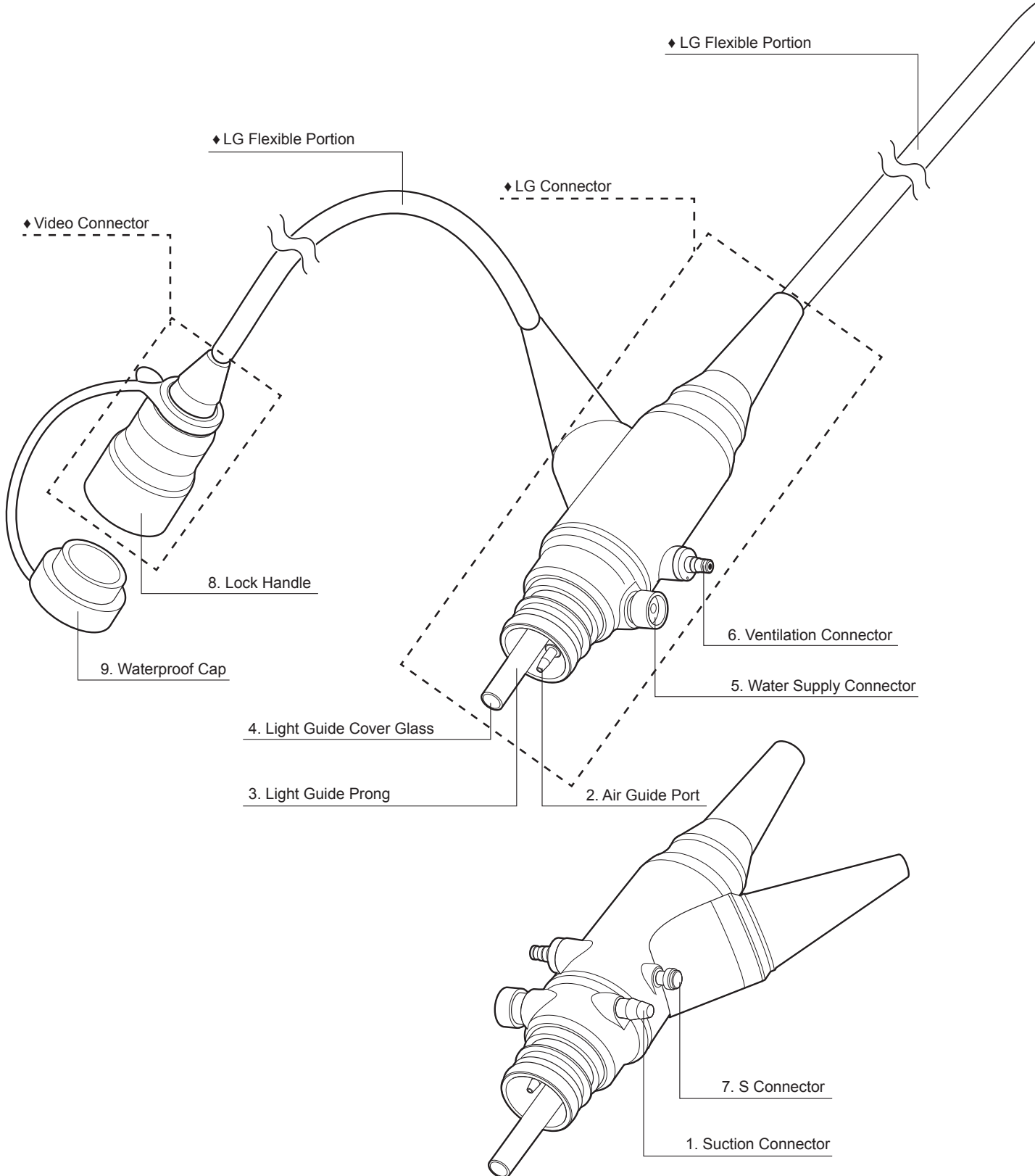

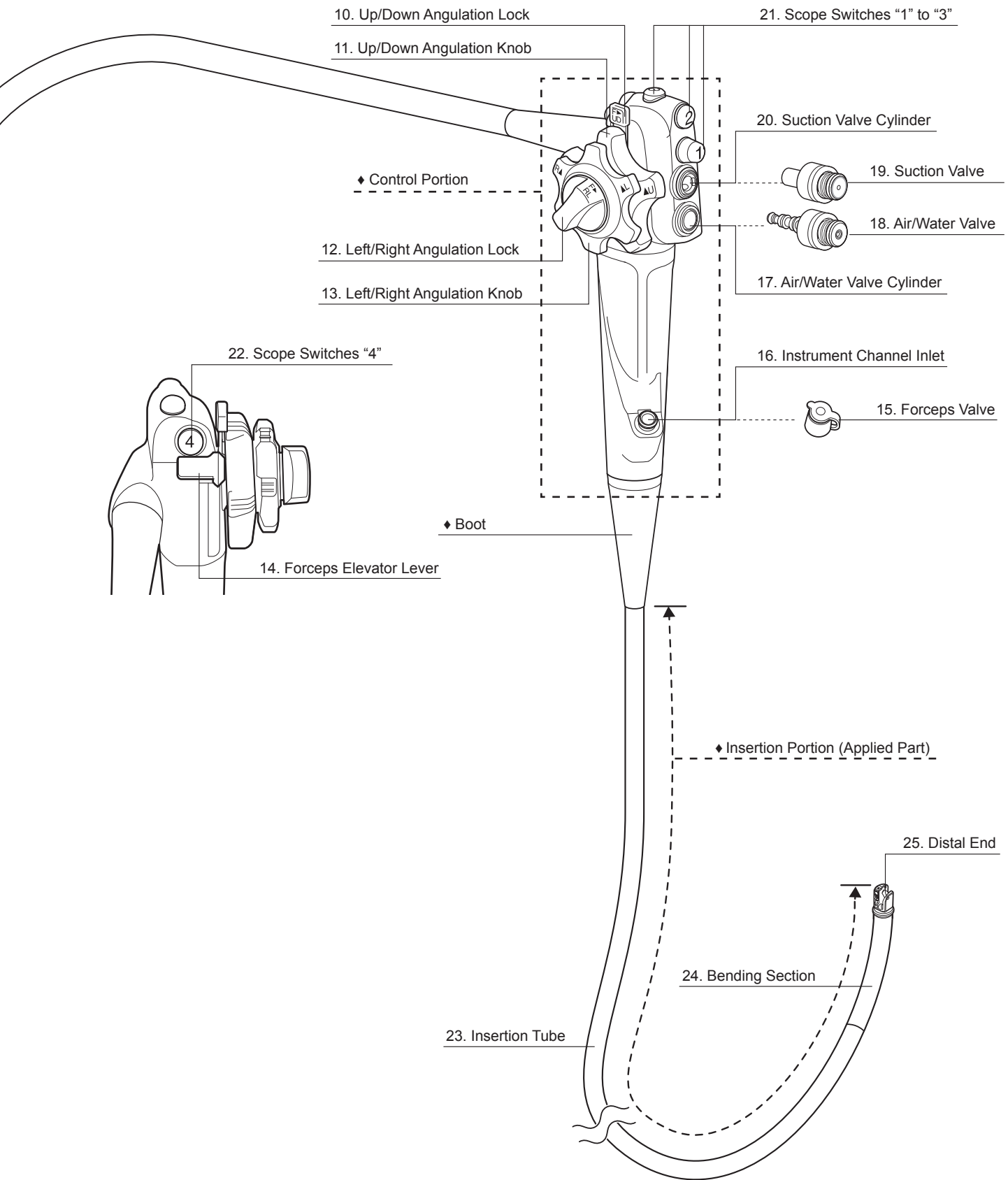

◆ LG Connector

The LG connector is connected to the light source.

No.	Name	Function
1	Suction Connector	Accepts the tube from the suction unit.
2	Air Guide Port	Supplies air from the pump of the light source to the endoscope.
3	Light Guide Prong	Transmits the light from the light source to the distal end.
4	Light Guide Cover Glass	
5	Water Supply Connector	Connects to the water tank.
6	Ventilation Connector	Connects to the air leak tester or ventilation adapter.
7	S Connector	Accepts the S-cord when using an electrosurgical unit.

◆ Video Connector

The video connector is connected to the processor.

No.	Name	Function
8	Lock Handle	Secures the video connector to the processor.
9	Waterproof Cap	Shields the electric contacts from the exposure to fluids.

◆ LG Flexible Portion

The LG flexible portion connects the LG connector and the control portion. This portion contains various internal channels, electrical wires and light guide.

◆ Interconnect Cable

The interconnect cable connects the video connector and the LG connector.

◆ Control Portion (G7 control portion)

The control portion is used for operating each function of the endoscope. Hold this portion during a procedure.

No.	Name	Function
10	Up/Down Angulation Lock	Maintains the up/down angle of the bending section. Moving this lock in the direction of F (Free) unlocks the up/down movement of the bending section, allowing external force to angulate the bending section freely. Moving this lock in the direction opposite to F locks the up/down movement and maintains the up/down angle of the bending section.
11	Up/Down Angulation Knob	Angulates the bending section upward or downward. Turning this knob in the direction of U angulates the bending section upward. Turning this knob in the direction of D angulates the bending section downward.
12	Left/Right Angulation Lock	Maintains the right/left angle of the bending section. Moving this lock in the direction of F (Free) unlocks the left/right movement of the bending section, allowing external force to angulate the bending section freely. Moving this lock in the direction opposite to F locks the right/left movement and maintains the right/left angle of the bending section.
13	Left/Right Angulation Knob	Angulates the bending section to the right or left. Turning this knob in the direction of L angulates the bending section to the left. Turning this knob in the direction of R angulates the bending section to the right.
14	Forceps Elevator Lever	Raises or lowers the forceps elevator. Turning this lever in the direction of U raises the forceps elevator. Turning this lever in the direction opposite to U lowers the forceps elevator.
15	Forceps Valve	One of the accessories for the endoscope. This valve is attached to the instrument channel inlet to prevent leak or backflow of air and/or fluids. In addition, an endotherapy device is inserted into or a syringe is attached to this valve.
16	Instrument Channel Inlet	Each endotherapy device is inserted from this inlet. An endotherapy device or fluid injected with a syringe passes through the instrument channel and comes out of the instrument channel outlet in the distal end of endoscope.
17	Air/Water Valve Cylinder	The air/water valve is attached to this cylinder.

No.	Name	Function
18	Air/Water Valve	One of the accessories for the endoscope. Pressing this valve supplies water and covering the hole in this valve with one's finger supplies air to the air/water nozzle in the distal end of the endoscope.
19	Suction Valve	One of the accessories for the endoscope. When this valve is pressed, suction is performed from the instrument channel outlet at the distal end through the instrument channel.
20	Suction Valve Cylinder	The suction valve is attached to this cylinder.
21 22	Scope Switches "1" to "4"	Functions of the processor are assigned to these switches. Use the processor to assign functions to these switches. → Operation Manual of the processor

◆ Boot

This portion connects the control portion and the insertion portion.

◆ Insertion Portion (Applied Part)

The insertion portion contains various components of the angulation system, internal channels, optical and illumination systems. The endoscope can be inserted into the body cavity up to the boot.

No.	Name	Function
23	Insertion Tube	Connects the bending section and the control portion. The index showing the distance from the distal end (Insertion Scale mark) is printed.
24	Bending Section	This section is bendable in any of the up, down, left and right directions by operating the up/down and left/right angulation knobs on the control portion. The distal end can be directed in any direction by moving this section.
25	Distal End	Contains the objective lens, light guide, air/water nozzle, instrument channel outlet, etc. → "2.3 Nomenclature and Functions of Distal End of Endoscope"

2.3 Nomenclature and Functions of Distal End of Endoscope

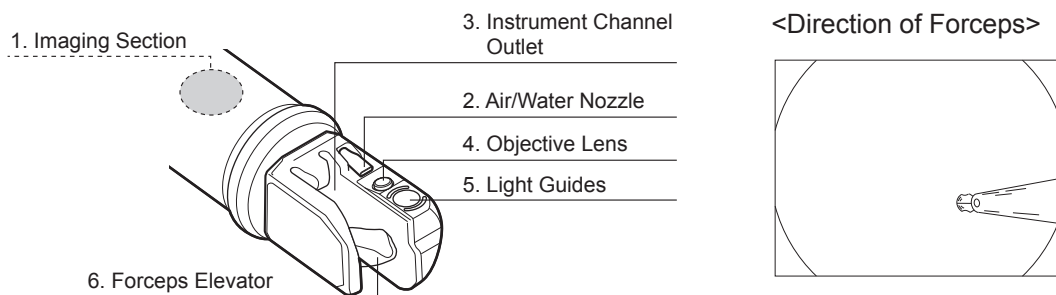

No.	Name	Function
1	Imaging Section	This section receives an image focused on its surface by the distal objective lens. This sensor is actually located within the distal portion of the endoscope in the illustrated position.
2	Air/Water Nozzle	This nozzle directs air or water onto the objective lens with the air/water valve operation.
3	Instrument Channel Outlet	Endotherapy devices exit from this opening when inserted from the instrument channel inlet. During operation of the suction valve, this opening serves as an entrance for suctioning of fluids into the instrument/suction channel.
4	Objective Lens	This lens focuses an image onto the imaging section which in turn is displayed on the monitor.
5	Light Guides	The light from the light guide cover glass is emitted from these windows.
6	Forceps Elevator	When the forceps elevator lever is operated, an endotherapy device is raised or lowered with this mechanism.

2.4 Location of Each Label

The positions where the labels are affixed on this product are shown below.

2.4.1 Location of Labels

<Control Portion>

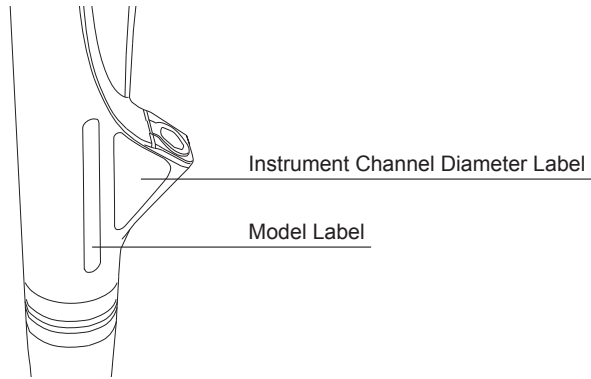

<LG Connector>

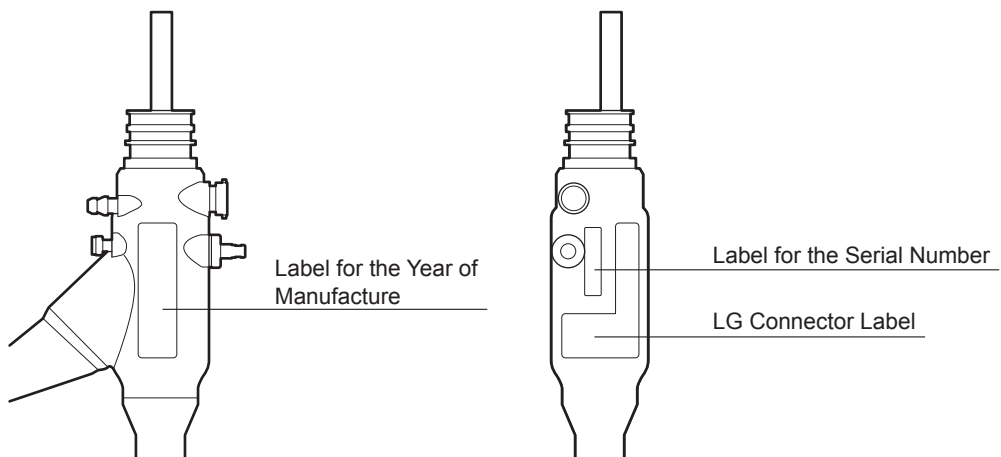

2.5 System Configuration

This product is used in combination with related equipment. The recommended combination of related equipment that can be used with this product is listed below. Related equipment is optional.

WARNING

- Use this product only in combination with related equipment described in this manual. Otherwise, it is unable to ensure its functionality, and may cause severe harm to patient or end-users.

CAUTION

- Use this product only in combination with related equipment described in this manual. Otherwise, it creates a risk of equipment malfunction.

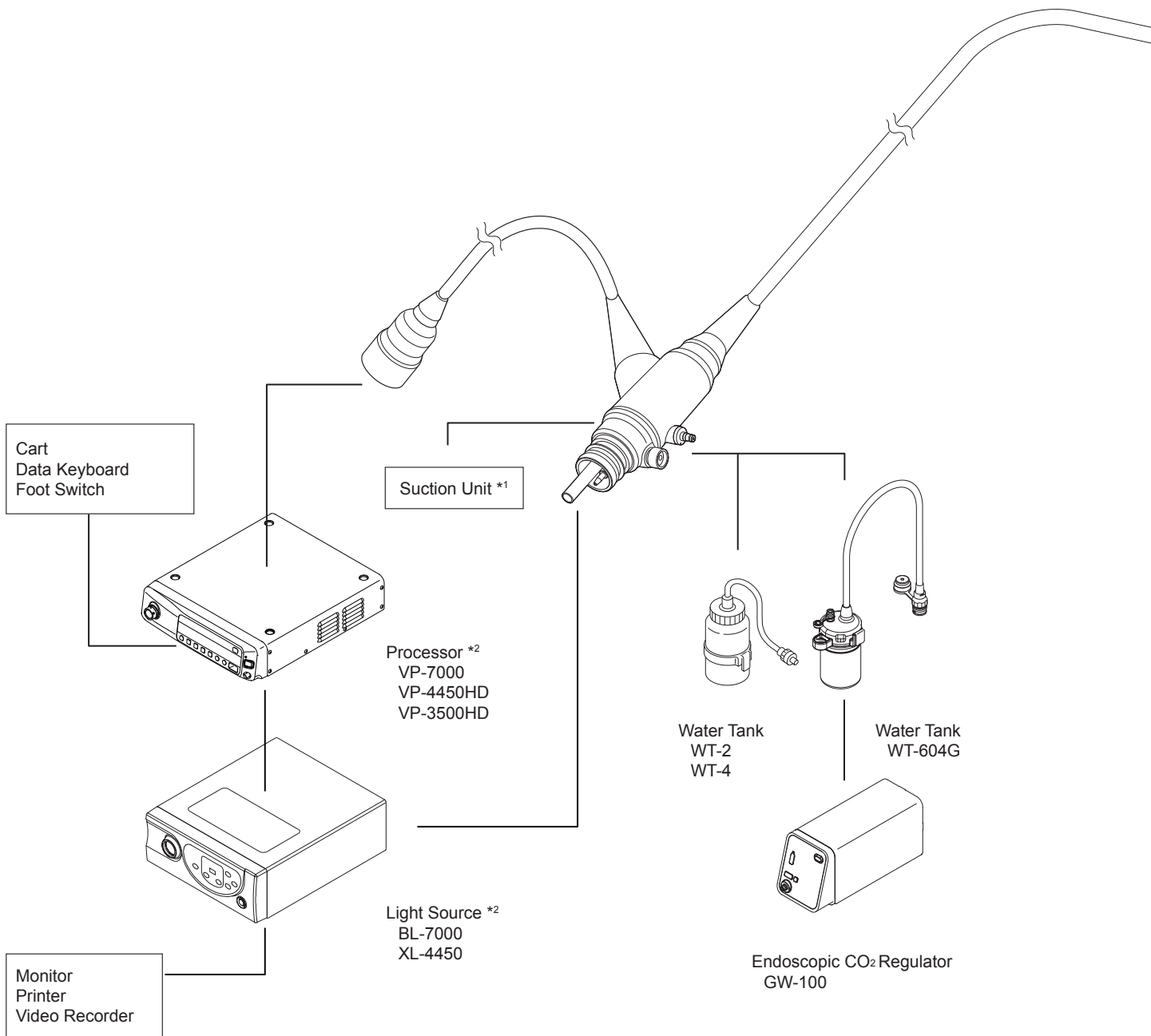

*1 Use a suction unit which complies with EN 60601-1 (IEC 60601-1) and can set suction pressure to 40 to 53 kPa.
 *2 The VP-7000 can only be used in combination with the BL-7000, and the BL-7000 with the VP-7000.

Note In addition to the related equipment described here, products that can be used in combination with this product may be added. In addition, the related equipment described here may have already been discontinued or not marketed depending on the country or region. For details on the devices used in combination with this product, contact your local FUJIFILM dealer.

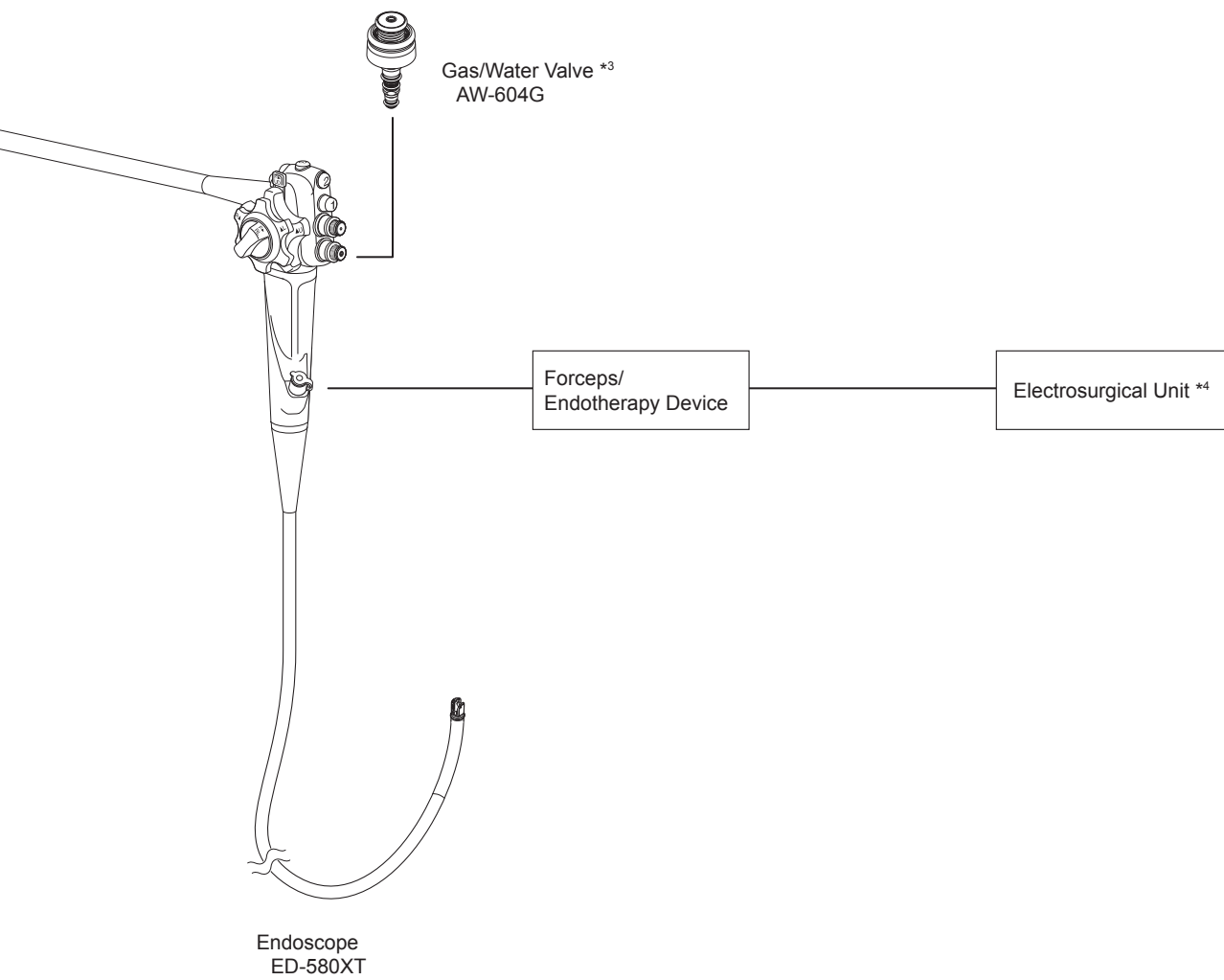

*3 Used in combination with the endoscopic CO₂ regulator GW-100.
*4 For details, refer to the manual of the electrosurgical unit.

Chapter **3** Workflow

This chapter describes the workflow of endoscopy, which differs depending on the type of endoscope and accessories to be used.

Have an understanding about the workflow and read the relevant sections thoroughly before use.

3.1 When Using Standard Functions

Inspecting Endoscope	Inspecting and Attaching Accessories	Connecting Related Equipment	Inspecting Each Function	
4.3.1 Inspecting Control Portion	4.4.1 Forceps Valve	4.5 Preparing Related Equipment	4.7.1 Inspecting Endoscopic Images	
4.3.2 Inspecting Insertion Portion	4.4.2 Suction Valve	4.6.1 Connecting to Light Source	4.7.2 Inspecting Scope Switch	
4.3.3 Inspecting Distal End	4.4.3 Air/Water Valve	4.6.2 Connecting to Processor	4.7.3 Inspecting Air/Water Supply Function	
4.3.4 Inspecting Bending Section	4.4.4 Distal End Cap	4.6.3 Attaching Water Tank	4.7.4 Inspecting Suction Function	
4.3.5 Inspecting Forceps Elevator Mechanism		4.6.4 Attaching Suction Unit		
4.3.6 Inspecting LG Connector				
4.3.7 Inspecting Video Connector				

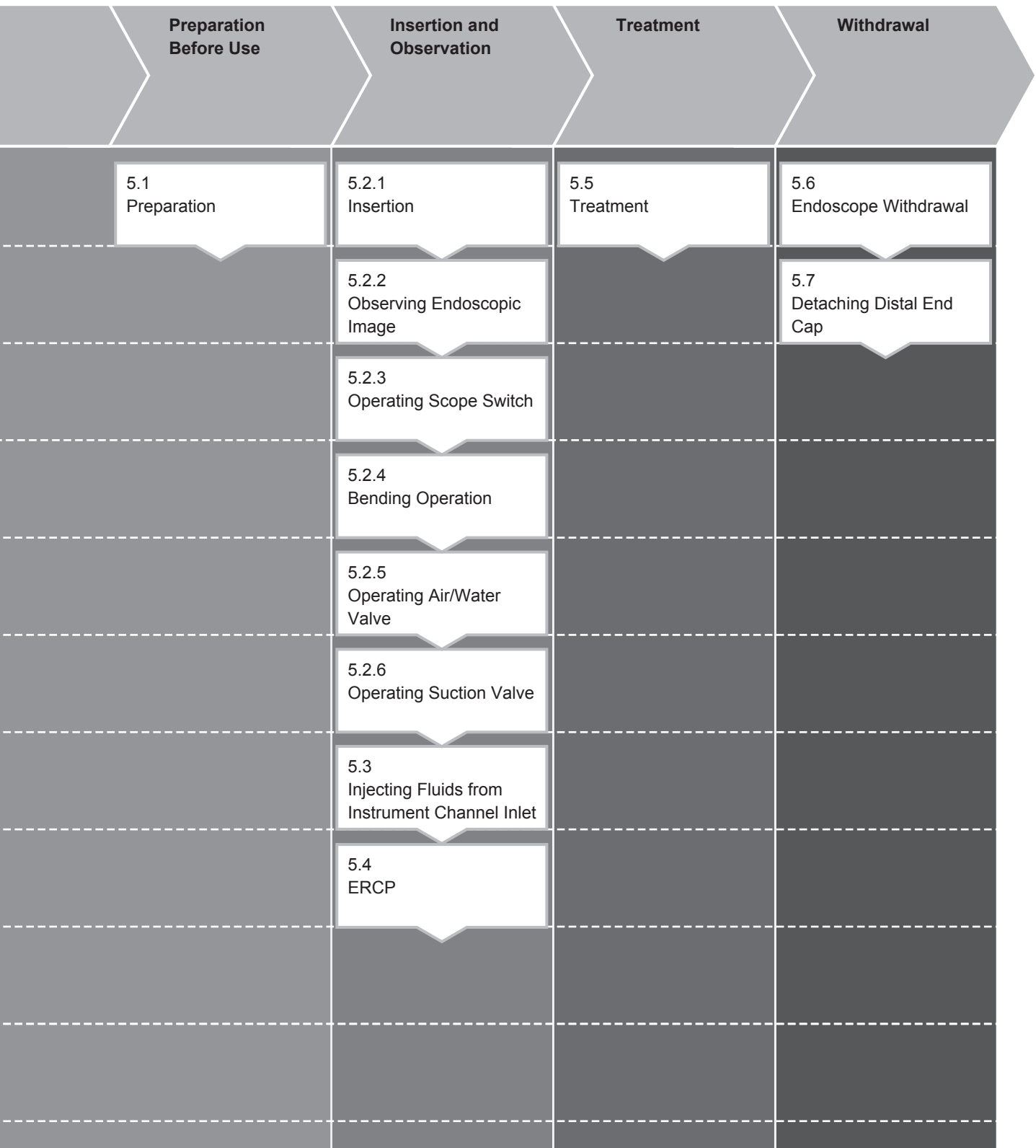

4 Preparation and Inspection

This chapter describes the inspection and preparation methods to be performed before using the endoscope, its accessories and related equipment.

Before using this product, perform preparation and inspection as per instructions provided in this chapter. In addition, inspect related products used in combination with this product as per instructions provided in respective operation manuals. If the inspection result shows any abnormality, refer to “Chapter 6 Troubleshooting.” If the problem persists, or if any failure is found, stop using the equipment and return it for repair according to “6.4 Returning Endoscope for Repair.”

WARNING

- The entire surface and each channel of the endoscope and the accessories must be reprocessed prior to first use, after any servicing, after any subsequent use, and after storage as per instructions provided in the Reprocessing Manual, even if the accessories were not used during a procedure. In addition, store this product as per instructions provided in the Reprocessing Manual. Inadequate reprocessing or storage may cause infection.
- Make sure to inspect the endoscope and accessories before use according to the procedures provided in this manual. Do not use the equipment that shows any signs of abnormality or irregularity. Use of abnormal equipment may lead to misdiagnosis or increase risks to patient safety.
- During an inspection or procedure, use sterile water. If sterile water is not used, it can create a risk of infection.

CAUTION

- Make sure to inspect the endoscope and accessories before use according to the procedures provided in this manual. Do not use the equipment that shows any signs of abnormality or irregularity. Use of abnormal equipment may cause equipment malfunction.
- If abnormalities and/or material changes including but not limited to cracking, flaking, pitting, corrosion, etc. which can create rough surfaces or sharp edges, holes/depressions, compromise sealed surfaces and/or negatively affect device functionality are found, contact your local FUJIFILM dealer.

Note The endoscope and accessories are not reprocessed before shipping from FUJIFILM. Reprocess them according to the instructions given in the Reprocessing Manual before using them in a procedure.

4.1 Preparation of the Equipment

Prepare the endoscope, accessories, related equipment and personal protective equipment. Related equipment not supplied with this product is optional. Also refer to the operation manual of related equipment and personal protective equipment.

◆ Endoscope

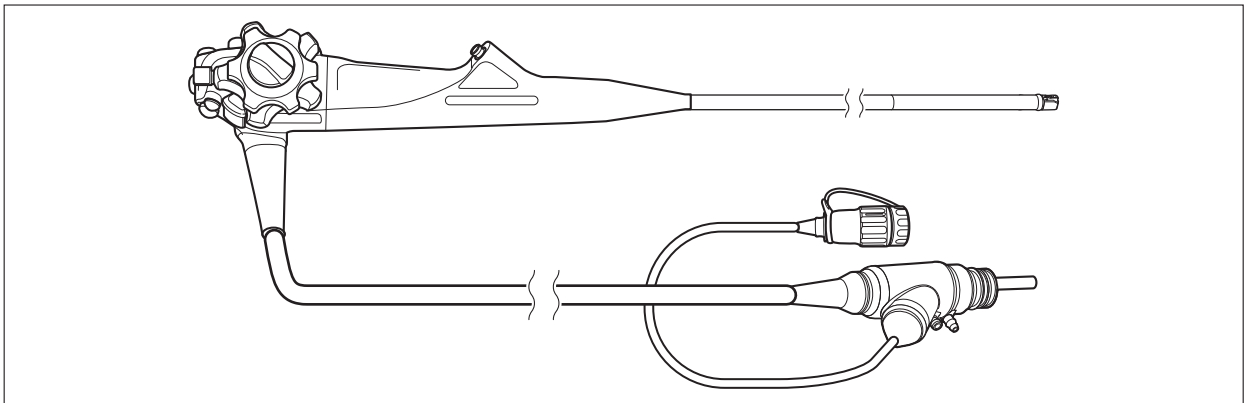

Note Prepare the endoscope that has been reprocessed as per instructions provided in the Reprocessing Manual.

◆ Accessories

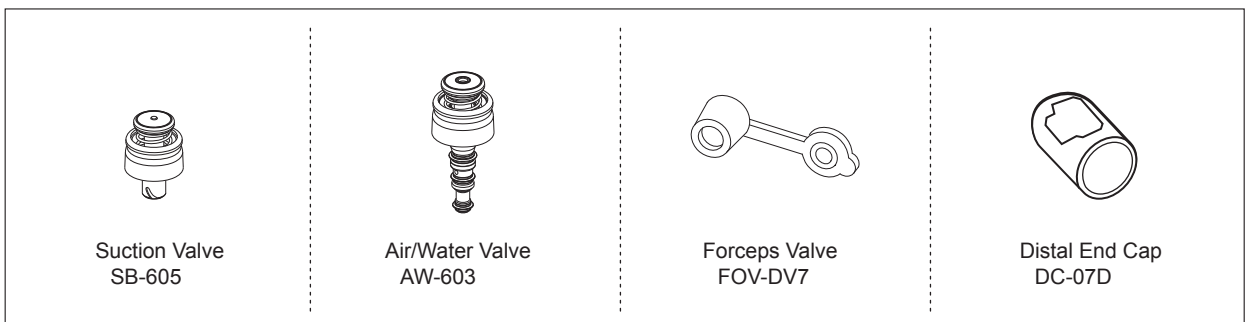

Note Prepare accessories that have been reprocessed as per instructions provided in the Reprocessing Manual.

◆ Related Equipment (Essential)

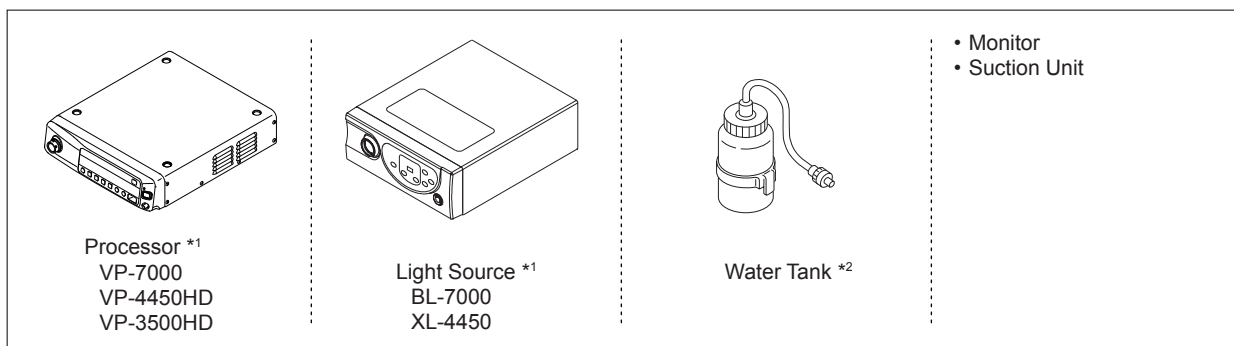

*1 The VP-7000 can only be used in combination with the BL-7000, and the BL-7000 with the VP-7000.

*2 Prepare the water tank that has been reprocessed as per instructions provided in the operation manual of the water tank.

◆ Related Equipment (To be Prepared when Necessary)

Note In addition to the devices described here, products that can be used in combination with this product may be added. In addition, the devices described here may have already been discontinued or not marketed depending on the country or region. For details on the devices used in combination with this product, contact your local FUJIFILM dealer.

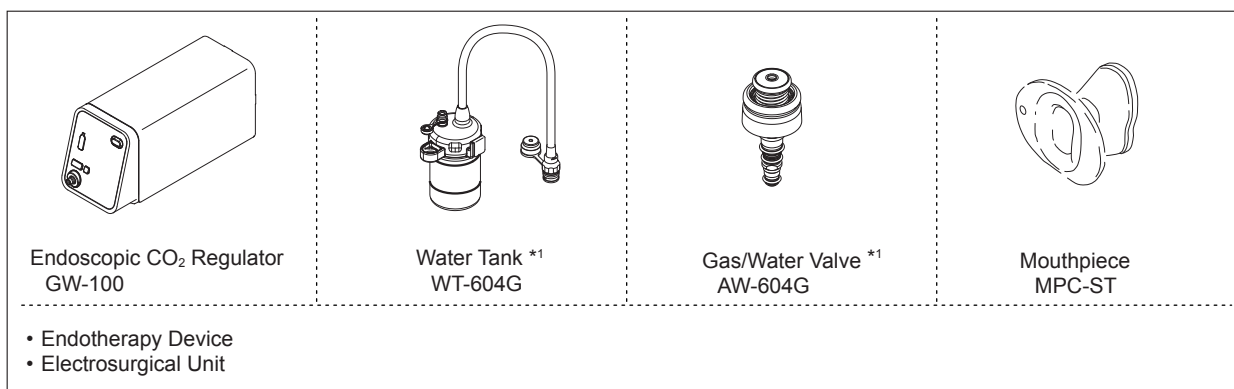

*1 Used in combination with the endoscopic CO₂ regulator GW-100.

Note Prepare related equipment that has been reprocessed as per instructions provided in the operation manual of related equipment.

◆ **Personal Protective Equipment**

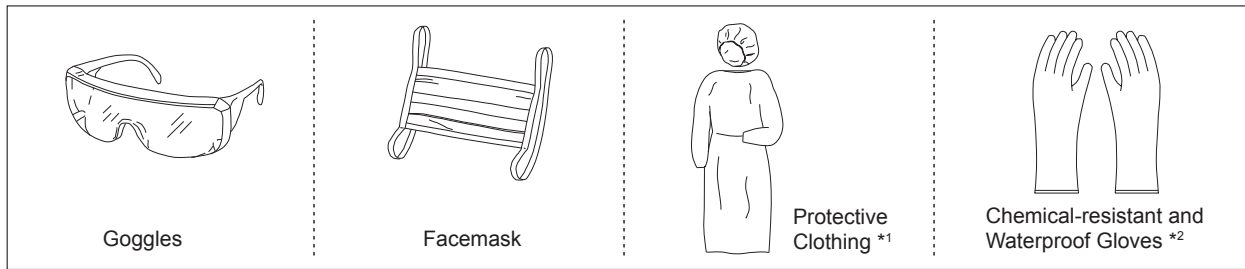

*1 It is also recommended to use shoes that can be disinfected and/or a single-use shoes cover.

*2 Chemical-resistant and waterproof gloves are recommended to be long enough to prevent your skin from being exposed.

◆ **Others**

- Sterile gauze
- Sterile water
- Sterile basin

4.2 Transporting Endoscope

This section explains how to transport the reprocessed endoscope. When transporting the endoscope that has been pre-cleaned after use, refer to the Reprocessing Manual.

→ “Reprocessing Manual”

WARNING

- Carry a reprocessed endoscope in a clean manner. If personal protective equipment such as gloves is contaminated, the contaminants adhere to the endoscope and it can be a source of infection.

CAUTION

- When transporting a reprocessed endoscope, firmly grasp the control portion and LG connector. If only the LG flexible portion or the boot is grasped, it may damage the endoscope.
- When transporting a reprocessed endoscope, do not coil the insertion tube or the LG flexible portion of the endoscope with a small diameter. Doing so may cause endoscope failure.

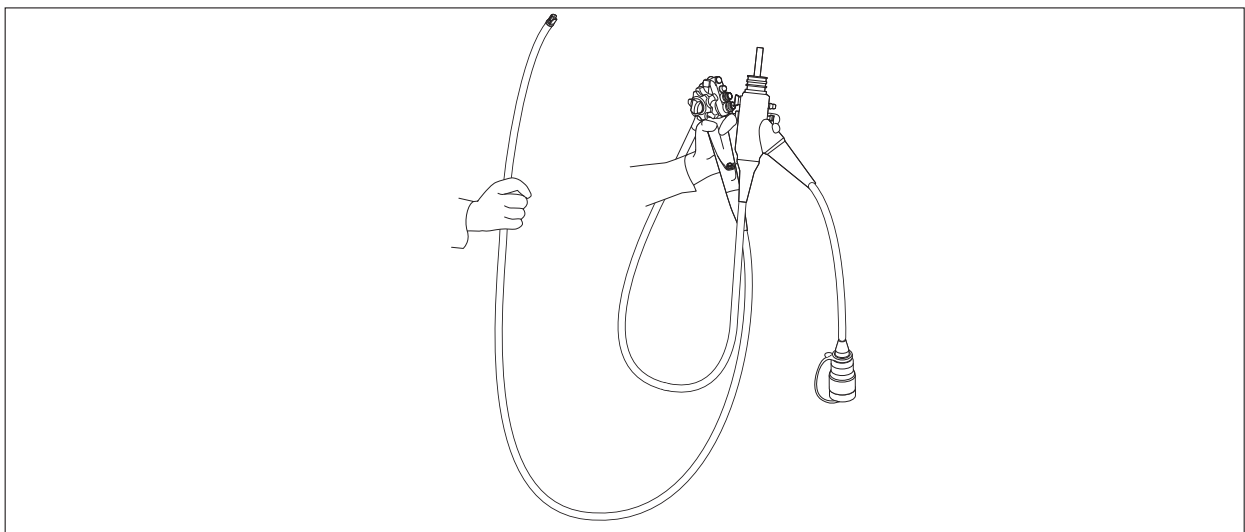

- (1) Prepare a reprocessed endoscope for transportation.
- (2) When carrying the endoscope by hand, loop the LG flexible portion, hold the LG connector with the control portion in one hand, and hold the distal end of the insertion tube gently in the other hand.

4.3 Inspecting Endoscope

Prior to inspection, make sure that dirt does not adhere to the endoscope. If dirt adheres to the endoscope, reprocess it according to the instructions given in the Reprocessing Manual.

4.3.1 Inspecting Control Portion

- (1) Visually and manually inspect the control portion for excessive scratches, deformation, cracks, residue, loose parts, or other irregularities.

4.3.2 Inspecting Insertion Portion

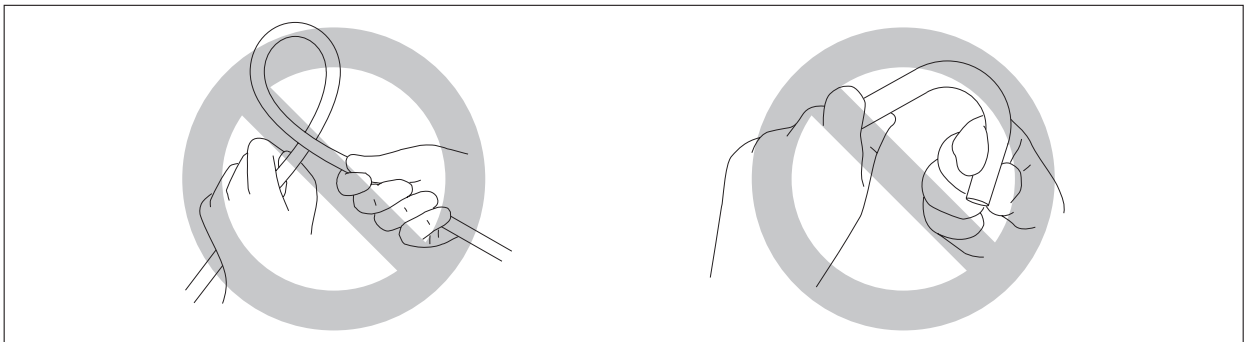

CAUTION

- Do not forcibly twist or bend the insertion tube of the endoscope. It could damage the endoscope.

- (1) Visually inspect the boot and the insertion portion near the boot for bends, twists, swelling or other irregularities.

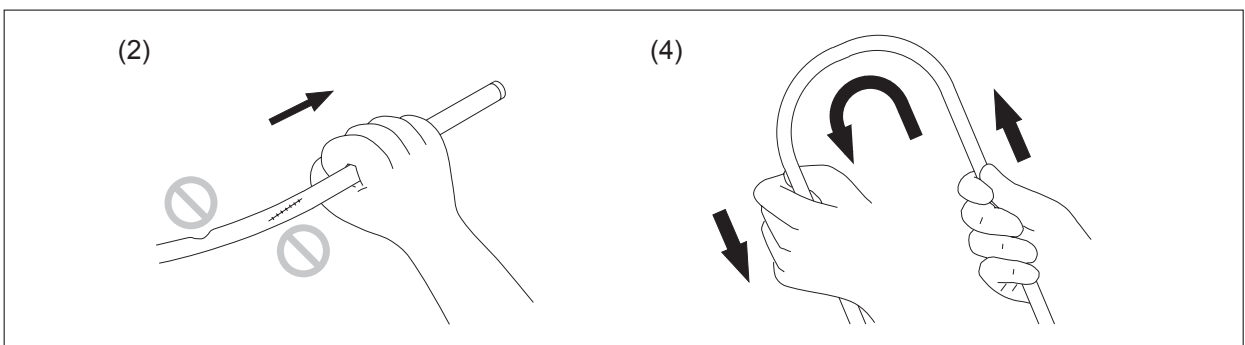

- (2) Visually and manually check the insertion portion (distal end, bending section and insertion tube) for abnormalities such as indentations, bumps, peeling, sharp edges or protrusions, etc. In addition, confirm that the insertion tube is not abnormally rigid.
- (3) Visually and manually check the bending section sheath and adhesives at each end of the bending section for abnormalities such as missing epoxy, roughness, pitting or flaking.

- (4) Hold the insertion tube with both hands to make a semicircle with a diameter of approximately 200 mm. Then, move the apex of semicircle sliding insertion tube for full length. Check that the tube bends fully and there are no areas of excessive rigidity or stiffness.

4.3.3 Inspecting Distal End

WARNING

- Turn off the light of the light source before inspecting the objective lens. Viewing the light from the light guide directly may damage your eyes.

- (1) Make sure that the light of the light source is turned off.
- (2) Visually and manually check the following points.
 - The objective lens is free from scratches, cracks or disengagement.
 - The areas around the objective lens are free from cracks or gaps.
 - The light guides are free from scratches, cracks or disengagement.
 - The areas around the light guides are free from abnormalities such as gaps.
 - The air/water nozzle is free from abnormalities such as cracks, abnormal protrusion, disengagement, crushes, dents or deformation.
 - The side surface of the distal end is free from abnormalities such as scratches, peeling or abnormal bulging.
 - The distal adhesives are free from abnormalities such as loss, peeling or deterioration.
 - All distal end surfaces are free from foreign residues, debris or sharp edges.

4.3.4 Inspecting Bending Section

WARNING

- Turn the up/down and left/right angulation knobs slowly in each direction until they stop. Repeat this operation several times to confirm that the bending section angulates smoothly and correctly. If the endoscope with an abnormal angulation knob is used, the bending section does not return to its neutral position, causing patient injury.

CAUTION

- Do not forcibly turn the angulation knob further after turning the knob until it stops. If the angulation knob is forcibly turned, it may cause malfunction of the endoscope.

◆ Inspection for Smooth Operation

- (1) Straighten the bending section.
- (2) Turn the up/down and left/right angulation locks in the direction of F (Free) until they stop to unlock the up/down and left/right angulation knobs and confirm that the up/down and left/right angulation knobs move smoothly.

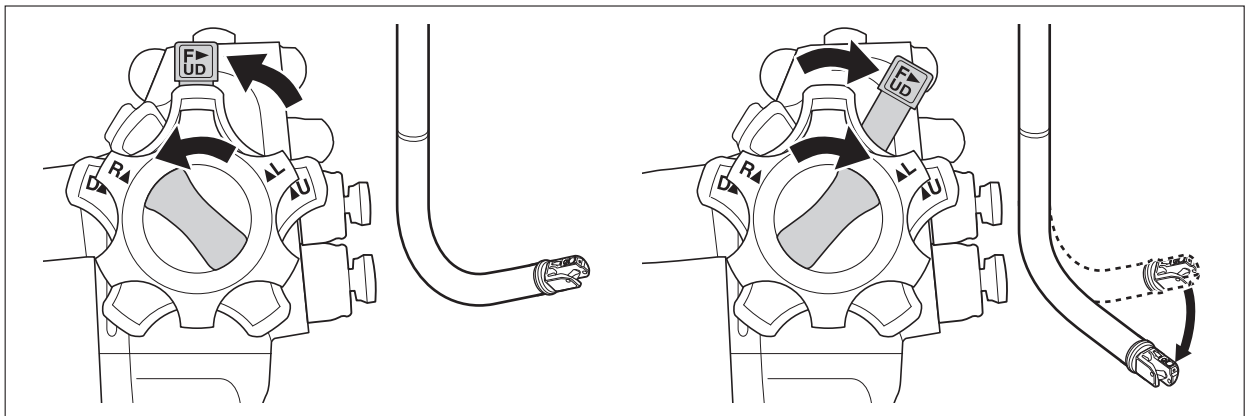

- (3) Slowly turn the up/down angulation knob in the directions of U and D and the left/right angulation knob in the directions of L and R. Ensure the distal tip moves to the desired direction, and then return them to their neutral position. Repeat this operation several times to confirm that the bending section angulates and returns to its neutral position smoothly and correctly.

<When the up/down and left/right angulation knobs are in the neutral positions>

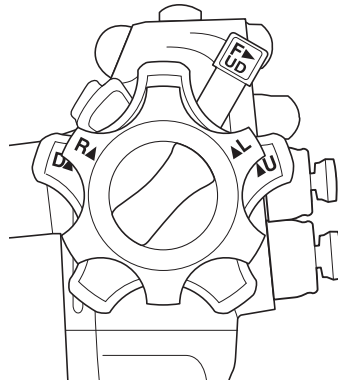

- (4) When the up/down and left/right angulation knobs are turned to their respective neutral positions, visually check that the bending section returns smoothly to an approximately straight condition.

◆ Inspecting Up/Down Angulation

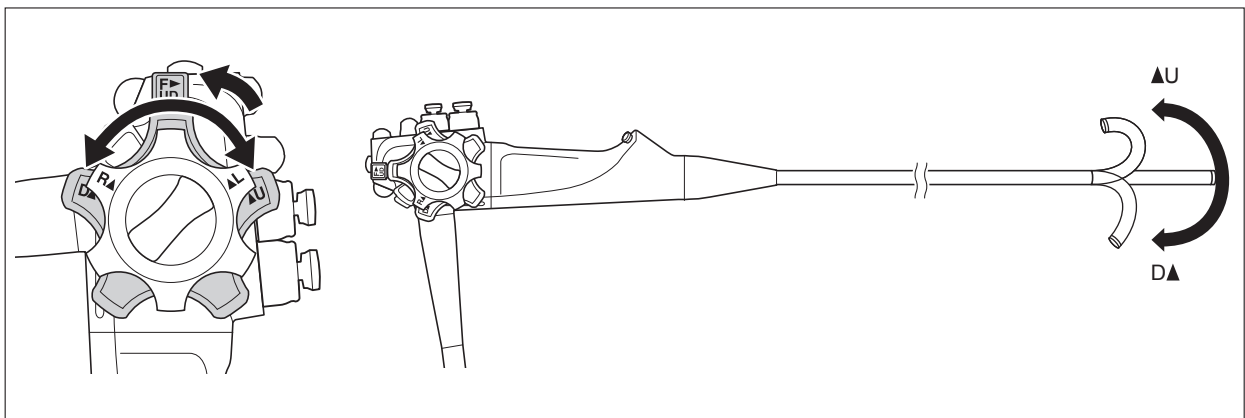

- (1) Move the up/down angulation lock all the way in the opposite direction of F (Free) to lock the up/down angulation knob.

Note When the up/down or left/right angulation lock is moved in the opposite direction of F (Free), the rotation of the up/down or left/right angulation knob becomes harder, and even when fully locked the angulation knob and the distal bending section still can be moved.

- (2) Turn the up/down angulation knob in the directions of U and D until it stops. Confirm that the angle of the bending section is roughly stabilized when the up/down angulation knob is released.
- (3) Move the up/down angulation lock all the way in the direction of F (Free) to unlock the up/down angulation knob. Confirm that the bending section moves back toward its neutral position when the up/down angulation knob is released.

◆ Inspecting Left/Right Angulation

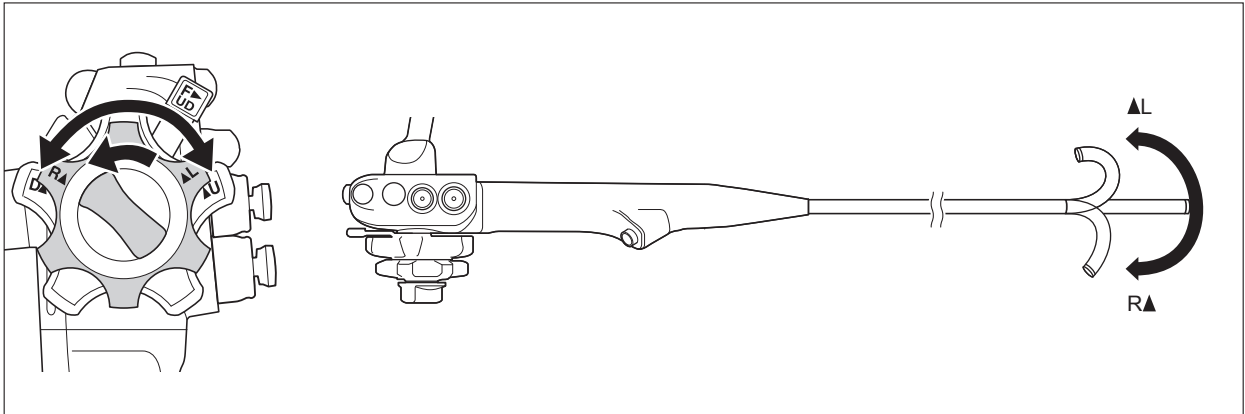

- (1) Move the left/right angulation lock all the way in the opposite direction of F (Free) to lock the left/right angulation knob.

Note When the up/down or left/right angulation lock is moved in the opposite direction of F (Free), the rotation of the up/down or left/right angulation knob becomes harder, and even when fully locked the angulation knob and the distal bending section still can be moved.

- (2) Turn the left/right angulation knob in the directions of L and R until it stops.
Confirm that the angle of the bending section is roughly stabilized when the left/right angulation knob is released.
- (3) Move the left/right angulation lock all the way in the direction of F (Free) to unlock the left/right angulation knob.
Confirm that the bending section moves back toward its neutral position when the left/right angulation knob is released.

4.3.5 Inspecting Forceps Elevator Mechanism

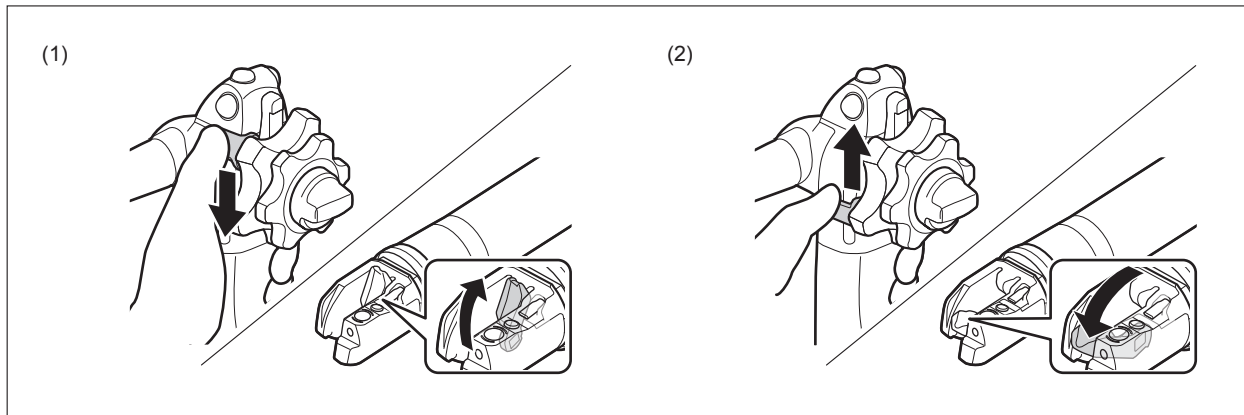

- (1) Lower the forceps elevator lever to raise the forceps elevator.
- (2) Raise the forceps elevator lever to lower the forceps elevator.

4.3.6 Inspecting LG Connector

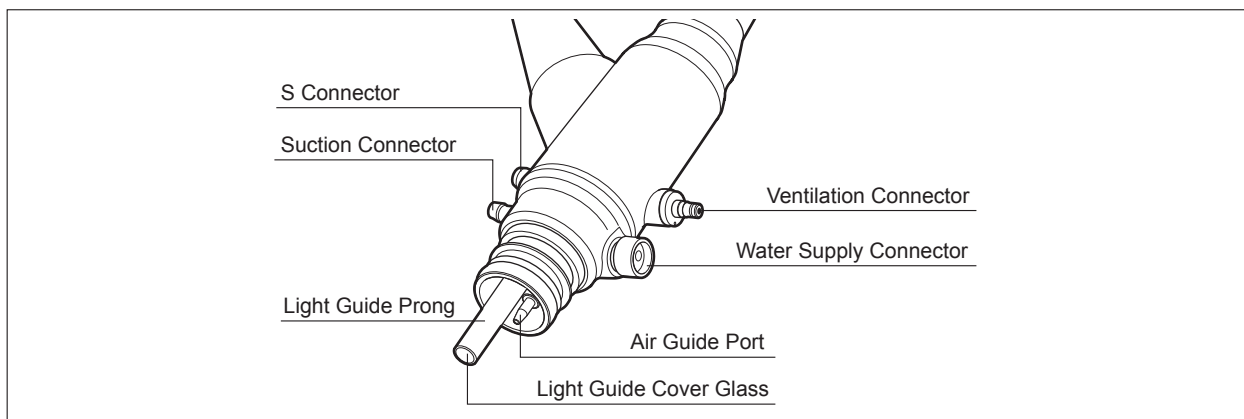

CAUTION

- Make sure that no moisture or foreign matter (such as dust, gauze fibers, metallic fragments) adheres to the LG connector before connecting it to the light source. If the LG connector with moisture or foreign matter (such as dust, gauze fibers, metallic fragments) is connected, it may cause malfunction or failure of the devices.
- Do not touch the light guide cover glass. A dirty light guide cover glass may result in the reduction of light intensity.

- (1) Visually and manually inspect the LG connector for abnormalities such as excessive scratching, dents, deformation or loose parts.
- (2) Before attaching the LG connector to the light source, make sure that no moisture or foreign matter (such as dust, gauze fibers) adheres to the light guide cover glass, air guide port, ventilation connector, water supply connector or suction connector of the LG connector. If any foreign matter is found, wipe it off with soft, sterile gauze moistened with alcohol.

4.3.7 Inspecting Video Connector

- (1) Visually and manually inspect the video connector for abnormalities such as dirt on the pin, broken or bent pin, excessive scratches, dents, deformation or loose parts.

4.4 Inspecting and Attaching Accessories

Prior to inspection, make sure that dirt does not adhere to the accessories. If dirt adheres to the accessories, reprocess them according to the instructions given in the Reprocessing Manual.

4.4.1 Forceps Valve

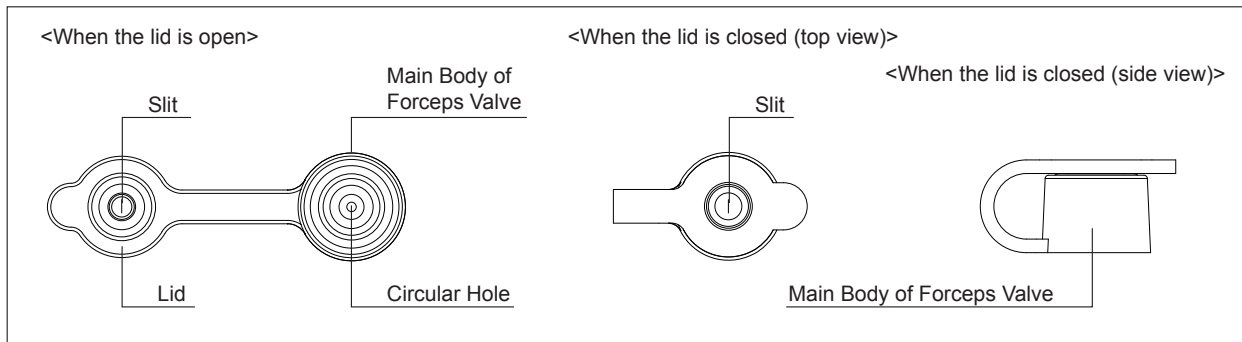

WARNING

- The forceps valve is intended for single use. Discard it after use. If a deteriorated forceps valve is used, body fluids may leak, causing infection.
- Reprocess the forceps valve before use. Use of an improperly reprocessed forceps valve can create a risk of infection.
- Make sure to check the forceps valve before use. If the inspection result shows any sign of abnormality or irregularity, replace the forceps valve with a new one already reprocessed. Use of an abnormal forceps valve may cause the leakage of body fluid, posing an infection risk.
- Ensure that the forceps valve is properly attached to the instrument channel inlet. If this product is used without the forceps valve attached, body fluid may leak and it could be a source of infection.

<Preparation>

The forceps valve is not reprocessed before shipping from FUJIFILM. Reprocess it according to the instructions given in the Reprocessing Manual before using it in a procedure.

→ Reprocessing Manual

<Inspection>

- (1) Confirm that the slit and circular hole on the forceps valve are free from abnormalities such as splits, cracks, deformations or discoloration.
- (2) Close the lid and visually check that there is no clearance between the lid and the main body of the forceps valve.

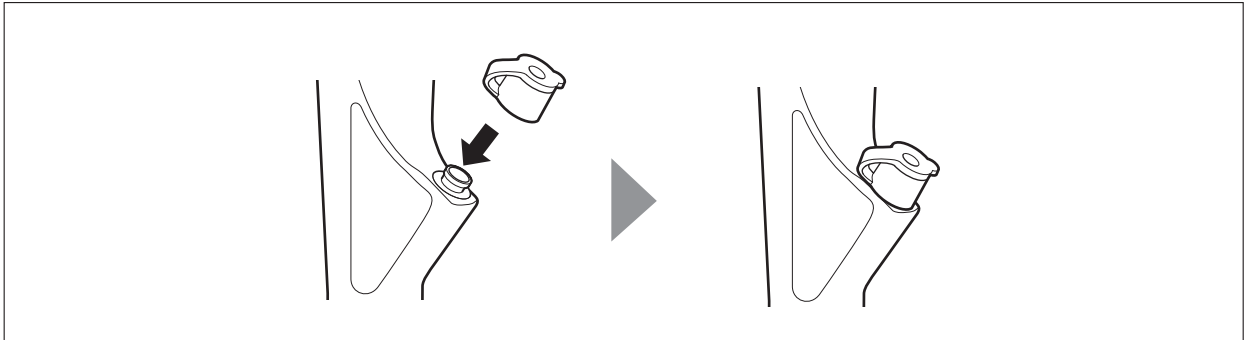
<Attachment>

- (1) Attach the forceps valve to the instrument channel inlet of the endoscope.

4.4.2 Suction Valve

Suction Valve (SB-605)

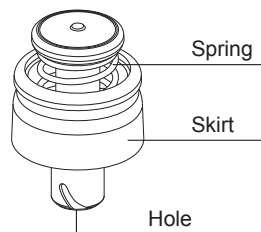
**WARNING**

- Use a properly reprocessed suction valve. Use of an improperly reprocessed suction valve could be a source of infection.

CAUTION

- When attaching the suction valve to the suction valve cylinder of the endoscope, align the recessed and projecting portions and slowly insert the suction valve straight into the suction valve cylinder of the endoscope. If the suction valve is attached forcibly, it may be damaged.

<Preparation>

The suction valve is not reprocessed before shipping from FUJIFILM. Reprocess it according to the instructions given in the Reprocessing Manual before using it in a procedure.

→ Reprocessing Manual

<Inspection>

Visually check that the suction valve is free from abnormalities such as tears, distortions, cracks, indentations, etc.

Note The suction valve is a consumable item. If any abnormality is found, use a new reprocessed valve.

<Attachment>

Note The suction valve and the suction valve cylinder have an orange marking. Check the marking on the suction valve and that on the suction valve cylinder to prevent an error in attachment.

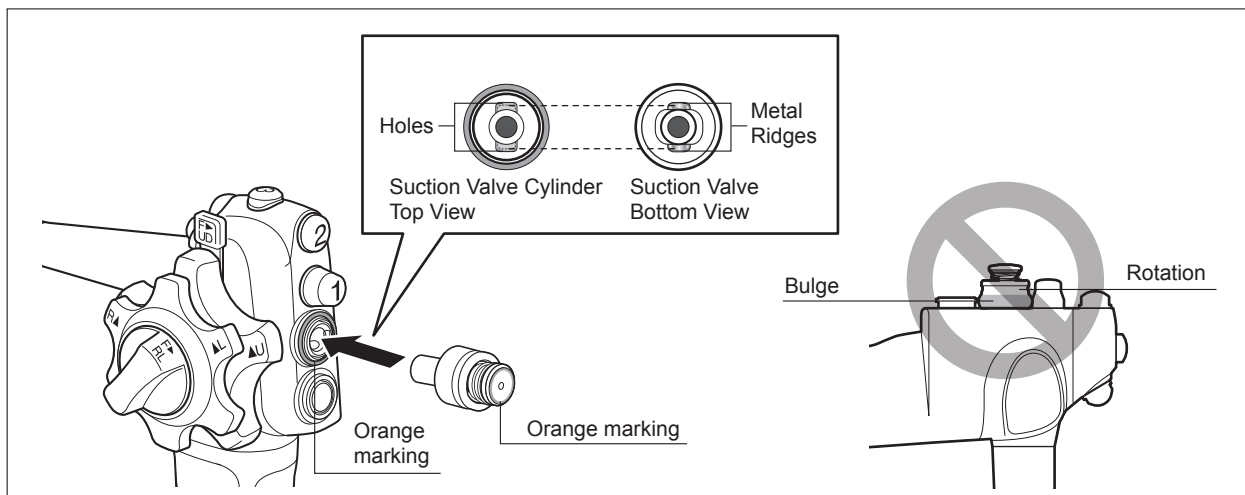

- (1) Attach the suction valve to the endoscope's suction valve cylinder, align the two metal ridges of the suction valve with the two holes in the suction valve cylinder, and push in the valve firmly.
- (2) Visually and manually check that the valve fits properly without any bulging of the skirt. Also confirm that the valve cannot be rotated.

4.4.3 Air/Water Valve

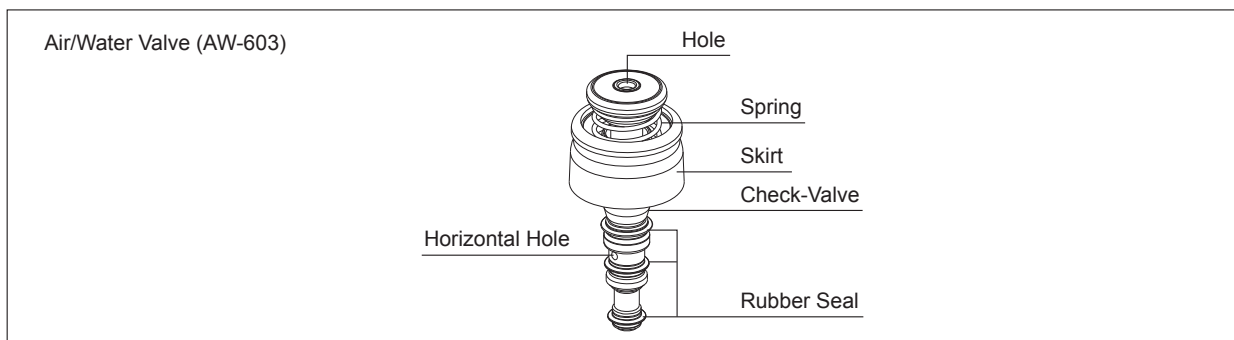

WARNING

- Use a properly reprocessed air/water valve. Use of an improperly reprocessed air/water valve could be a source of infection.
- Use the air/water channel cleaning adapter only for pre-cleaning of the air/water channel. If it is used during a procedure, continuous air supply may occur and cause patient injury.

CAUTION

- Do not use any lubricants (except sterile water) to the air/water valve. It may impair the functionality of the valve or may clog the channel, diminishing functionality of air/water supply.

<Preparation>

The air/water valve is not reprocessed before shipping from FUJIFILM. Reprocess it according to the instructions given in the Reprocessing Manual before using it in a procedure.

→ Reprocessing Manual

<Inspection>

- (1) Visually check that the hole of the air/water valve is not blocked.
- (2) Visually check that the air/water valve is not deformed or cracked.

Note The air/water valve is a consumable item. If any abnormality is found, use a new reprocessed valve.

- (3) Visually check the air/water valve for excessive scratching or tears in the valve's seals.

<Attachment>

CAUTION

- Slowly insert the air/water valve straight into the air/water valve cylinder of the endoscope. If the air/water valve is attached forcibly, it may be damaged.

Note The air/water valve and the air/water valve cylinder have a blue marking. Check the marking on the air/water valve and that on the air/water valve cylinder to prevent an error in attachment.

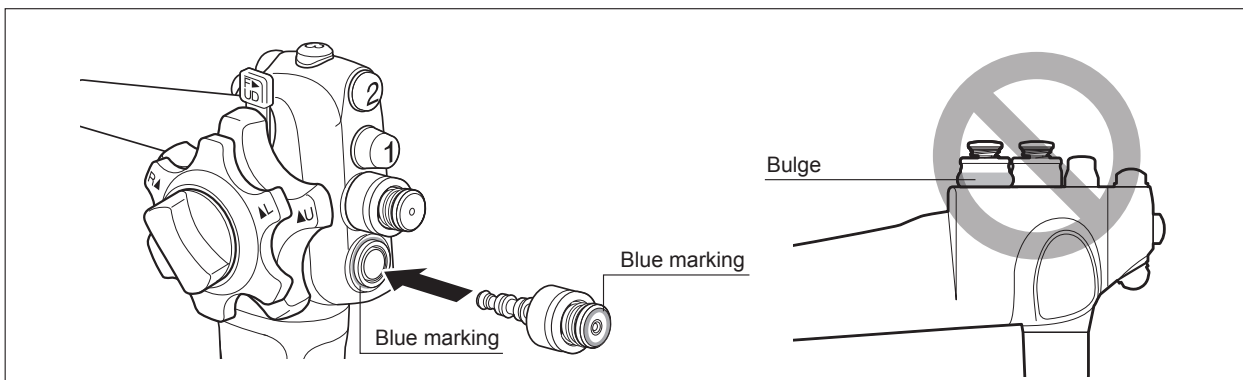

- (1) Attach the air/water valve to the endoscope's air/water valve cylinder, and push in the valve firmly.
- (2) Visually and manually check that the valve fits properly without any bulging of the skirt.

4.4.4 Distal End Cap

Distal End Cap (DC-07D)

**WARNING**

- The distal end cap is intended for single use. Discard it after use. Use of a deteriorated distal end cap can pose a risk of infection.
- Reprocess the distal end cap before use. Use of an improperly reprocessed distal end cap can pose a risk of infection.
- Make sure to check the distal end cap before use. If the inspection result shows any sign of abnormality or irregularity, replace the distal end cap with a new one already reprocessed. Use of an abnormal distal end cap can pose a risk of infection.
- Attach the distal end cap before inserting the endoscope. Not doing so may cause injury to tissues in the body cavity, bleeding and/or perforation.

CAUTION

- Do not hold the bending portion tightly when attaching or detaching the distal end cap. There is a risk of damaging the endoscope.

<Preparation>

The distal end cap is not reprocessed before shipping from FUJIFILM. Reprocess it according to the instructions given in the Reprocessing Manual before using it in a procedure.

→ Reprocessing Manual

<Inspection>

Visually check that the distal end cap is free from abnormalities such as adhesion of foreign substances, tears, distortions, cracks, indentations, etc.

Note The distal end cap is a consumable item. If any abnormality is found, use a new reprocessed cap.

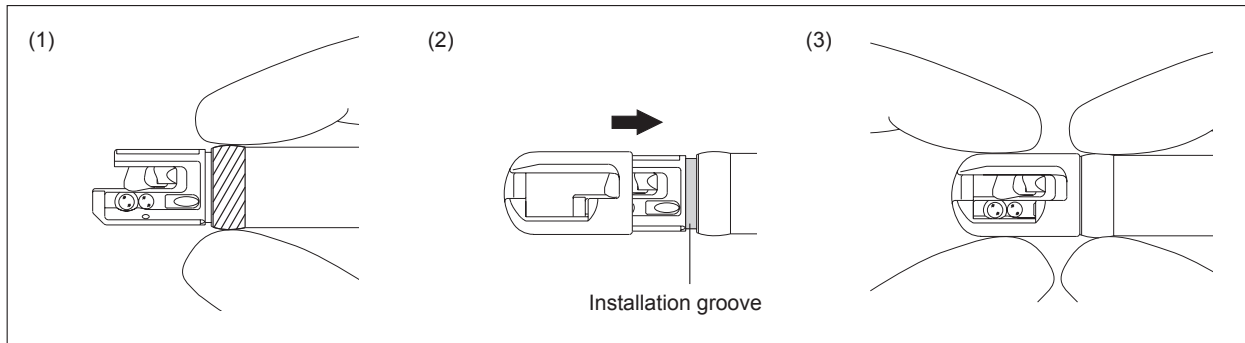
<Attachment>

- (1) Hold the bending section (hard portion).
- (2) Cover the distal end cap until the installation groove of the distal end is hidden completely.
- (3) Embed the distal end cap into the installation groove by pushing the edge of the cap with one's finger.

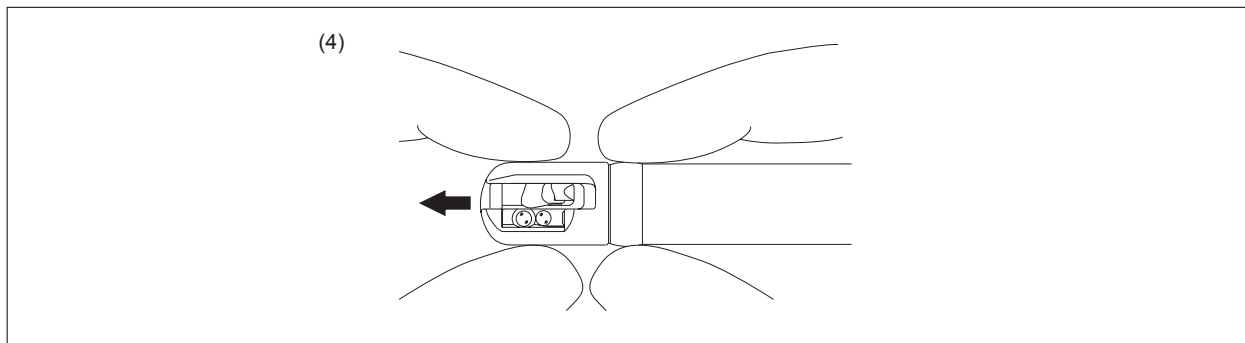

- (4) Make sure that the distal end cap is attached tightly by pulling it straight.

4.5 Preparing Related Equipment

Prepare related equipment such as the following as per instructions provided in each operation manual.

- Light source
- Processor
- Monitor
- Water tank
- Suction unit
- Endotherapy device
- Mouthpiece
- Endoscopic CO₂ Regulator
- Electrosurgical unit

4.5.1 Inspecting Related Equipment

Inspect related equipment as per instructions provided in each operation manual.

Note Some pieces of related equipment are not reprocessed before shipping from FUJIFILM or the manufacturer. Reprocess them for the first time prior to use as per instructions provided in respective operation manuals.

4.5.2 Preparing System

CAUTION

- With regard to the amount of sterile water in the water tank, follow the instructions provided in the operation manual of the water tank. If the amount of sterile water in the water tank exceeds the limit, the air/water supply function may be disabled or it may cause equipment failure due to contact with spilled water.
- Use the endoscopic CO₂ regulator described in this manual. If another insufflation device is connected, the air/water supply function lessens and may result in improper cleaning of the lens.

- (1) Move the cart with the processor, light source and other related equipment to the place where endoscope is to be used.

Note

- Refer to the Operation Manual of the processor/light source to install related equipment onto the cart.
- When multiple foot switches are used, check the position of the corresponding foot switch in advance, so as not to use the wrong foot switch by mistake.

- (2) After turning the main switch on the cart to OFF position, insert the AC plug of the cart into a hospital grade receptacle.

- (3) Prepare the suction unit.

Note For details on the suction unit, refer to the “manual” of the suction unit.

- (4) Mount the water tank, 80% filled with sterile water, on the cart or light source.

Note

- The water in the water tank should be changed at least daily using sterile water.
- Use a reprocessed water tank.
- FUJIFILM water tanks must be reprocessed at least daily. These water containers are 24-hour multiple patient use devices which should not be used longer than 24 hours without additional reprocessing.

4.6 Connecting Endoscope to Light Source, Processor and Related Equipment

This section explains how to connect the endoscope to the light source, processor and related equipment.

4.6.1 Connecting to Light Source

WARNING

- Firmly connect the LG connector of the endoscope and the light source as well as the video connector and the processor. If the LG connector is not connected properly, the endoscopic image may flicker or be lost, which may cause patient injury, bleeding and/or perforation.

CAUTION

- Firmly connect the LG connector of the endoscope and the light source. Do not look into the connecting part between the endoscope and the light source. Light leaking from the connecting part may cause damage to the eyes.
- Immediately after detaching the LG connector from the light source, do not touch the light guide prong with hands since it may be extremely hot. There is a risk of burn injury.

- (1) Make sure that the light source, processor and related equipment are turned off.

Note The endoscope can be connected or disconnected when the EXAM. indicator lamp on the processor is set to "STANDBY." For details, refer to the operation manual of the processor.

- (2) Make sure that no moisture or foreign matter (such as dust, gauze fibers, metallic fragments) adheres to the light guide prong of the LG connector.

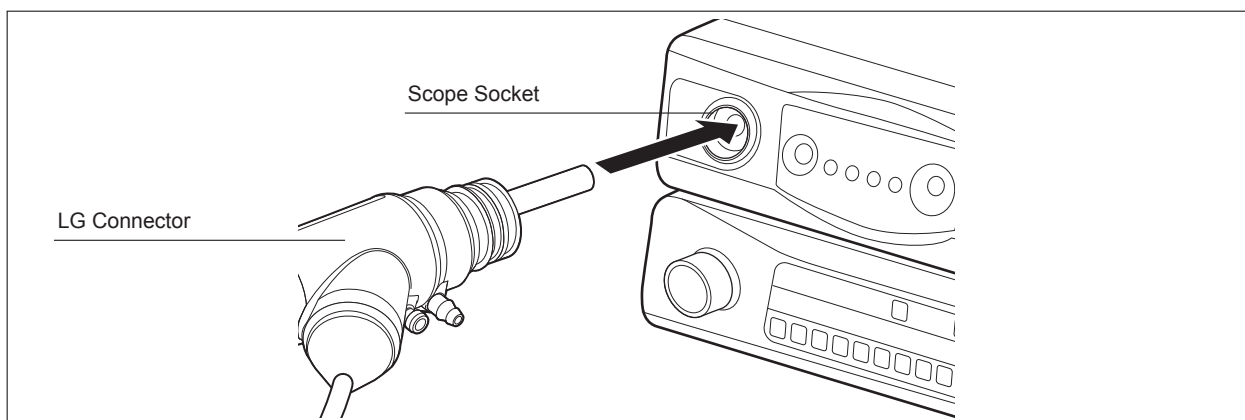

- (3) Insert the LG connector straight into the scope socket of the light source until it stops.
- (4) Visually check that the LG connector is fully inserted.

4.6.2 Connecting to Processor

WARNING

- Firmly connect the video connector of the endoscope and the processor. If the video connector is not connected properly, the endoscopic image may flicker or be lost, which may cause patient injury, bleeding and/or perforation.

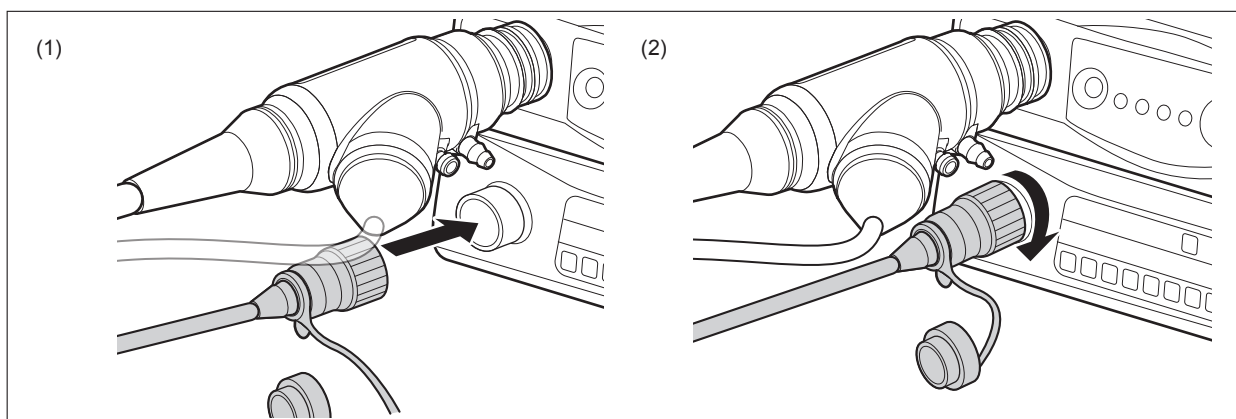

- (1) Align the index on the video connector and that on the 500 system connector socket of the processor, and insert the video connector into the processor.
- (2) Rotate the lock handle clockwise while pressing the video connector further into the processor to secure the connector.
- (3) Attach a dedicated connector cap to the connector socket that is not in use.

4.6.3 Attaching Water Tank

CAUTION

- Attach the water tank to the specified position of the cart or light source. Otherwise, fluid may leak from the connector of the water tank and it may come into contact with related equipment, causing equipment failure.

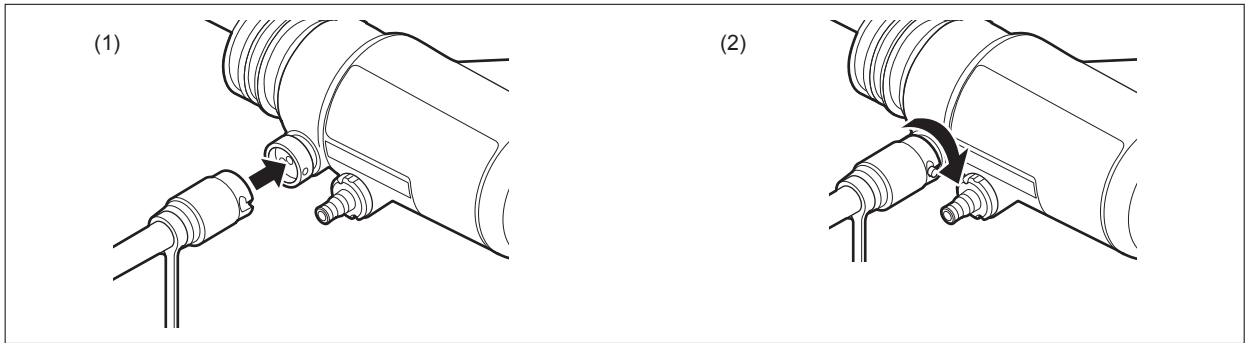

- (1) Align the pin of the water supply connector of the endoscope to the groove in the connector of the water tank.
- (2) Insert the connector of the water tank straight into the water supply connector and attach it firmly by turning the connector clockwise until it stops.
- (3) Visually check that the water supply connector of the endoscope and the connector of the water tank are connected properly.

4.6.4 Attaching Suction Unit

WARNING

- Firmly connect the suction tube from the suction unit to the suction connector on the LG connector. If the suction tube is not attached properly, body fluid may drip from the tube and can pose an infection control risk.

CAUTION

- Firmly connect the suction tube from the suction unit to the suction connector on the LG connector. If the suction tube is not attached properly, body fluid may drip from the tube and come into contact with related equipment, causing equipment failure.

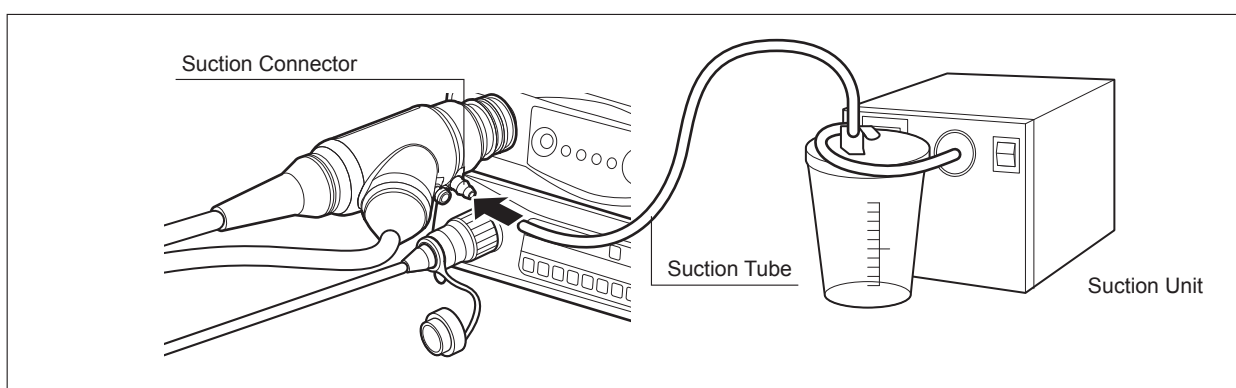

- (1) Firmly connect the suction tube from the suction unit to the suction connector of the endoscope.

4.7 Inspecting Functions Used in Combination with Related Equipment

4.7.1 Inspecting Endoscopic Images

Confirm that endoscopic images are normally displayed on the monitor and that the images are clear, sharp, of appropriate color and accuracy of observed target sites.

WARNING

- Do not look directly into the light coming from the light guide at the distal end of the endoscope. Viewing the light from the light guide directly may damage your eyes.

CAUTION

- When turning off the processor, also turn off the light source. If the light source remains on after turning off the processor, the ALC (automatic light control) does not function and the maximum amount of light is emitted. As a result, the distal end of the endoscope and its surroundings may become hot, causing burn injury to the patient or end-user.
- Turn off the light of the light source except during an inspection or procedure, etc., when necessary. If the light of the light source is left on, the distal end of the endoscope and its surroundings may become hot, causing burn injury to the patient or end-user.

Note Use the processor to assign functions on each scope switch. For details, see the operation manual of the processor.

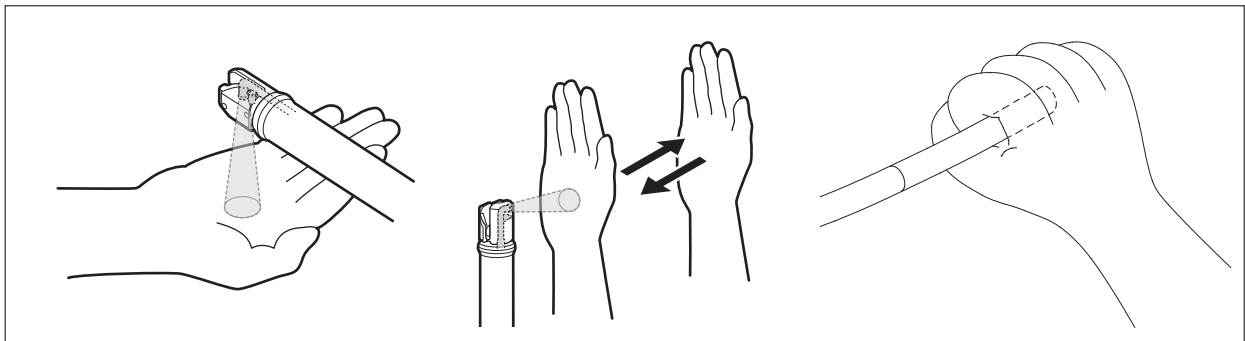

- (1) Turn on the cart, processor, light source and monitor.
- (2) Turn on the light of the light source and make sure that the light is emitted from the light guide of the distal end.
- (3) Observe the endoscopic image while moving your palm toward and away from the objective lens or lightly grasping the distal end. Confirm that the endoscopic image is free from noise, blur, fog, or other irregularities.

Note If the endoscopic image cannot be seen clearly, wipe the objective lens with sterile gauze moistened with alcohol.

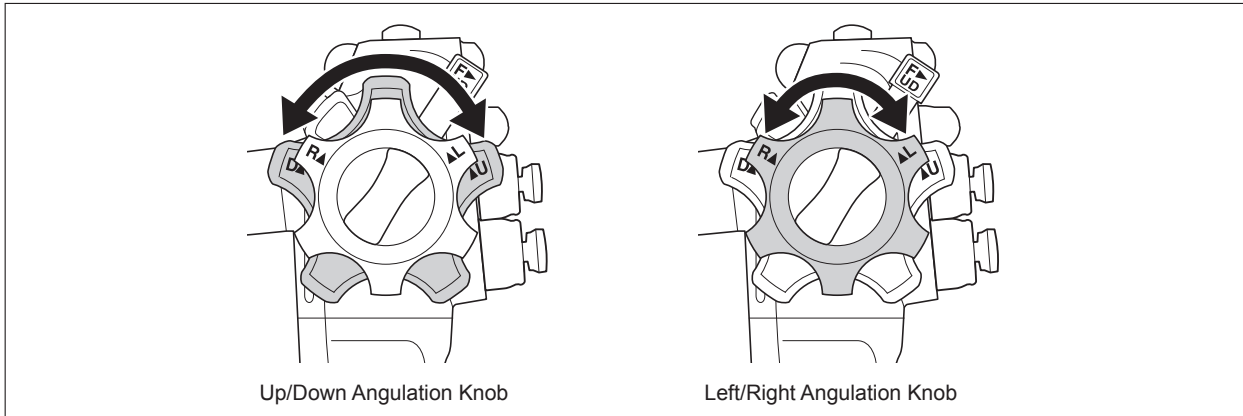

- (4) Angulate the bending section by operating the up/down or left/right angulation knob of the endoscope and confirm that the endoscopic image is free from momentary disappearing or other irregularities.

4.7.2 Inspecting Scope Switch

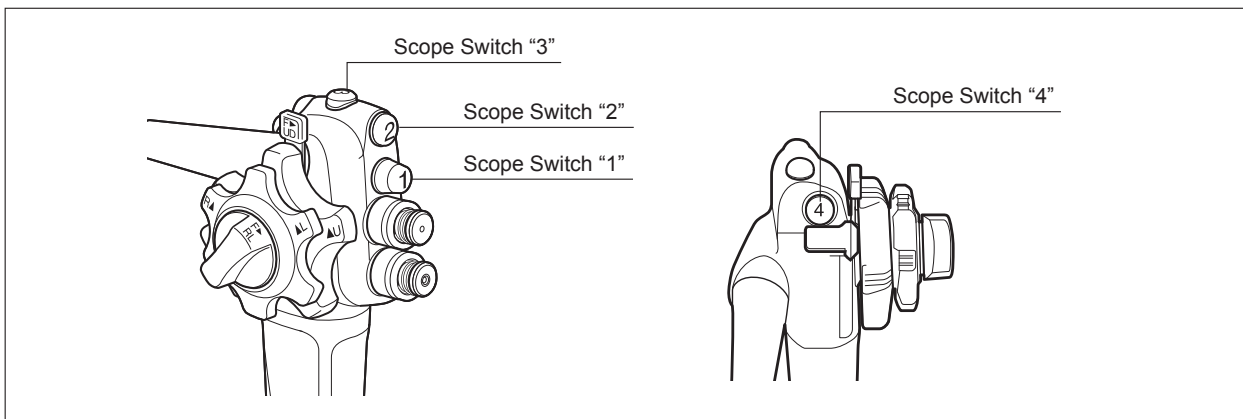

- (1) Confirm that the assigned function is executed by pressing each scope switch.

Note Use the processor to assign functions on each scope switch. For details, see the operation manual of the processor.

4.7.3 Inspecting Air/Water Supply Function

WARNING

- If water leaks from the air/water valve during the inspection of the air/water supply function, replace it with a new one already reprocessed. A leaking air/water valve may cause backflow of body fluid, posing an infection control risk.

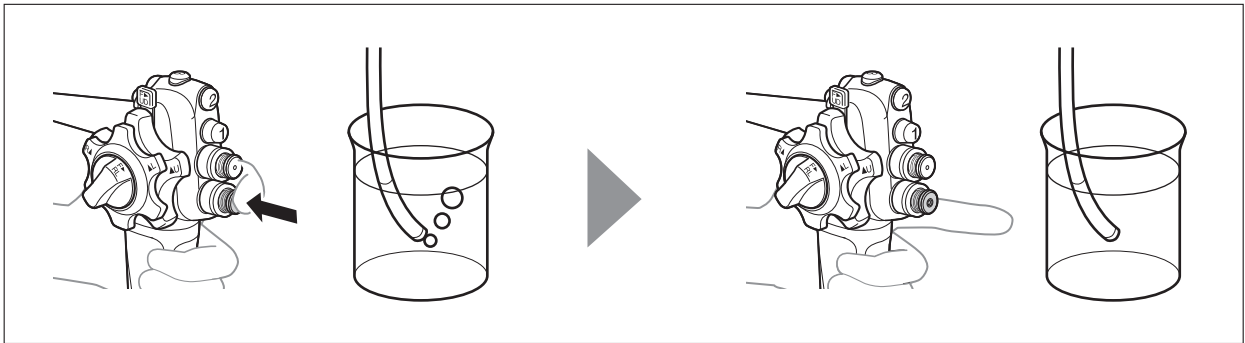

- (1) Turn on the suction unit, cart, processor and light source. Keep the light of the light source off.
- (2) Prepare a container of sterile water.
- (3) Immerse the distal end of the endoscope in sterile water to a depth of about 60 mm and confirm that no air bubbles come out of the air/water nozzle.

Note When the distal end of the endoscope is immersed less than 60 mm below the surface of the sterile water, a small amount of air bubbles may come out from the air/water nozzle even when the hole in the air/water valve is not covered. This does not indicate a malfunction.

- (4) Cover the center hole of the air/water valve with your finger, and be sure that air comes out of the air/water nozzle. Release your finger from the hole and check that air does not come out of the nozzle.

Note Manipulation method differs when a gas/water valve for an endoscopic CO₂ regulator is used. For details on how to use, refer to the operation manual of the endoscopic CO₂ regulator.

- (5) While still within the container, withdraw the scope tip to just above the fluid, then press the air/water valve, and check that sterile water comes out of the air/water nozzle.

Note Note the direction in which sterile water comes out. Water should flow directly over the objective lens.

- (6) Release the air/water valve. Confirm that water supply stops and the valve returns to its original position.
- (7) Set the air supply pump's operation of the light source to "OFF."

4.7.4 Inspecting Suction Function

WARNING

- If water leaks from the forceps valve or suction valve during the inspection of the suction function, replace it with a new one already reprocessed. A leaking forceps valve or suction valve may cause backflow of body fluid, posing an infection control risk.

- (1) Confirm that the suction unit is turned on and the suction pressure is set to 40 to 53 kPa.
- (2) Immerse the distal end of endoscope in sterile water, and check that pressing the suction valve aspirates sterile water.

Note Check that the forceps valve has been properly attached to the instrument channel inlet of the endoscope. If it is not attached properly, water cannot be aspirated.

- (3) Release the suction valve. Confirm that suction stops and the valve returns to its original position.

Chapter 5 How to Use

This chapter describes the basic operation procedures of this product and precautions to observe.

This product is intended for use by medical professionals who have received proper training in endoscopic procedures at medical facilities under the management of physicians. This manual does not provide information about procedures or any aspects of endoscopic techniques.

WARNING

- Make sure to inspect the endoscope and accessories before use according to the procedures provided in this manual. Do not use the equipment that shows any signs of abnormality or irregularity. Use of abnormal equipment may lead to misdiagnosis or increase risks to patient safety.
- Wear personal protective equipment (such as goggles, facemask, chemical-resistant and waterproof gloves, antifouling protective clothing, cap and shoe covers) during a procedure as well as during reprocessing to protect your eye and skin and to prevent infection. Not doing so may cause infection.
- Do not supply an excessive amount of air or gas during a procedure. Doing so may cause patient pain, injury to tissues in the body cavity, bleeding, perforation and/or embolism.
- During an inspection or procedure, use sterile water. If sterile water is not used, it can create a risk of infection.
- Never use endotherapy devices, operate, insert or withdraw the endoscope, or operate the related equipment without viewing or while freezing the endoscopic image on the monitor. Otherwise, injury to tissues in the body cavity, bleeding and/or perforation may result.

- Note**
- Always observe the patient closely. If the patient has symptoms suggestive of an embolism, discontinue the endoscopic procedure immediately and give proper medical treatment.
 - Ensure that all related equipment has been properly prepared and processed as per instructions provided with each item.

CAUTION

- Do not subject the video connector or the LG connector to strong impact. Install the processor and the light source away from obstacles to prevent the video connector connected to the processor and the LG connector connected to the light source from accidental impact damage. During the operation of an electric bed, etc., ensure that the video connector connected to the processor or the LG connector connected to the light source does not hit the bed. Otherwise, the endoscope's video connector and LG connector, processor and light source may malfunction.
- Do not push the boot of the control portion against the bed, etc. during a procedure. Doing so may cause endoscope failure.

5.1 Preparation

5.1.1 Preparing Related Equipment

Prepare related equipment to be used, including back-up or spare endoscope, scope components (valves, distal caps, etc.) and accessories (ex. water tank, endotherapy devices, etc.)

5.1.2 Pretreatment of Patient

Prepare the patient in the normal endoscopy regimen.

5.1.3 Preparing Mouthpiece

Prepare a mouthpiece per manufacturer's instructions.

WARNING

- Use an appropriate mouthpiece as per manufacturer's instructions, including specific reprocessing recommendations.

CAUTION

- Do not use a mouthpiece that is damaged, deformed, or reveals other irregularities. Doing so may cause injury in the oral cavity and/or equipment failure.

Note Reusable mouthpieces are considered consumable items. If any abnormality is found, use a new mouthpiece per manufacturer's instructions.

- (1) Before oral insertion, have the patient hold the mouthpiece in his/her mouth.

Note If you choose to have the patient hold the mouthpiece after insertion, attach the mouthpiece to the insertion portion in advance. Have the patient hold it promptly after insertion.

5.2 Insertion and Observation

5.2.1 Insertion

WARNING

- Do not forcibly advance or withdraw the endoscope into/from the patient, angulate the bending section forcibly or operate it quickly. It may cause patient injury, bleeding or perforation.
- If a patient sneezes or moves abruptly during the procedure, malfunction of the endoscope and patient bleeding or trauma may occur. Depending on the degree of malfunction, safe endoscope withdrawal may be difficult or impossible, causing severe harm to patient and/or end-users.

CAUTION

- Do not directly apply Xylocaine spray to the insertion portion. Do not use olive oil as a lubricant for insertion. It may cause deterioration of the outer surface.
- Securely attach the distal end cap to the distal end of the endoscope before use. If the distal end cap is not attached securely, the distal end cap may fall off during use.
- Use this product in combination with the distal end cap DC-07D. If another type of distal end cap is used in combination with this product, the distal end cap may fall off during use.
- If the distal end cap becomes misaligned or falls off during a procedure, stop the procedure immediately and slowly withdraw the endoscope. Otherwise, it may cause injury to tissues in the body cavity.
- If you encounter any resistance during a procedure, insert the endoscope slowly. Do not force it in. Do not insert or bend the endoscope without securing the view on the monitor. Not following the recommendations above may cause endoscope failure or patient injury.
- Lower the forceps elevator before inserting the endoscope. Not doing so may cause patient injury.

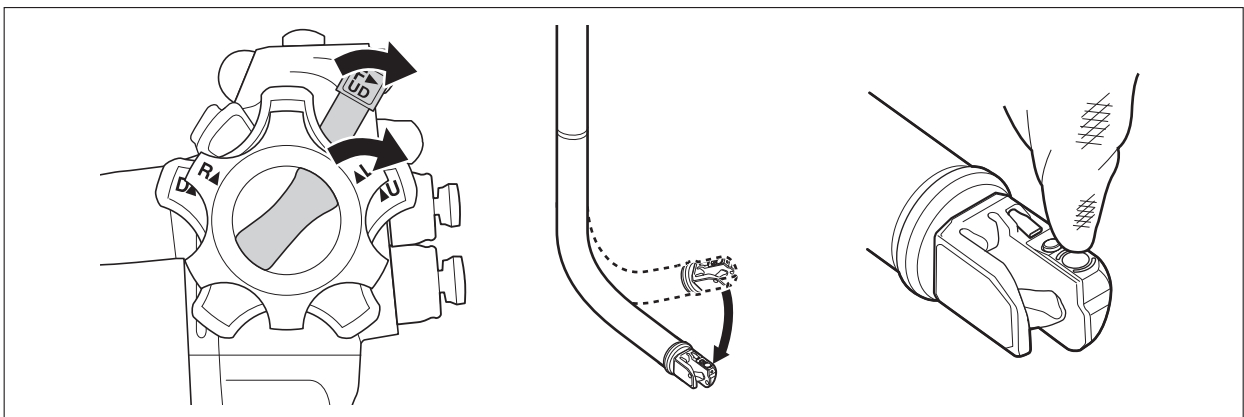

- (1) Patients should lie on examining table in an appropriate position as required for the specific type of endoscopy procedure to be performed.

- (2) Unlock the bending section by turning the up/down and left/right angulation locks in the direction of F (Free) until they stop.

Note The procedure described above is recommended. However, other techniques are also available: you can insert endoscope by locking the bending section only in the left-right direction and unlocking it in the up-down direction.

- (3) Raise the forceps elevator lever to lower the forceps elevator.
- (4) When necessary, wipe the objective lens and light guides with sterile gauze moistened with alcohol.

Note Use lint-free sterile gauze to prevent fibers from entering the air/water nozzle.

- (5) Apply clean lubricant (Xylocaine jelly or the like) to the insertion portion.

- (6) Turn on the light of the light source.

Note If the light source is off, press the power button to turn it on.

- (7) Set the air supply pump's operation of the light source to "HI", "MID" or "LOW."
- (8) Insert the distal end of endoscope into the oral cavity and then move it down to the pharynx while under constant observation.

5.2.2 Observing Endoscopic Image

Refer to the operation manual of the light source and processor for instructions on how to adjust the brightness, color, etc.

CAUTION

- During an observation, do not perform close observation for an extended period of time. Use the endoscope with a minimum necessary amount of brightness and time while maintaining an appropriate distance. Thermal energy created by illumination may cause burn injury.
- When the shutter speed is set to "HIGH", take care not to set the brightness level too high. Thermal energy created by illumination may cause burn injury.
- If the brightness level of the light source or processor is high, the surface temperature at and around the distal end of the endoscope may exceed 41°C. Do not allow the distal end to remain in contact with the same site for an extended period of time. It may cause burn injury.

Note

- In cases with bleeding, use the light save function of the light source. Patient's blood adhering to light guide at the distal end of endoscope may be coagulated by the energy of illumination. For details on how to use the light save function, refer to the operation manual of light source.
- If any steam-like smoke appears in the endoscopic image, or if the endoscopic image becomes dark, blood or other substances may adhere to the light guide at the distal end of endoscope. Withdraw the endoscope from the patient immediately, remove foreign matter, make sure that the light guide has no abnormality, and then use the endoscope again. If foreign matter is not removed, the temperature at the distal end of endoscope may rise, causing damage to the endoscope or burn injury to the patient or operator.

5.2.3 Operating Scope Switch

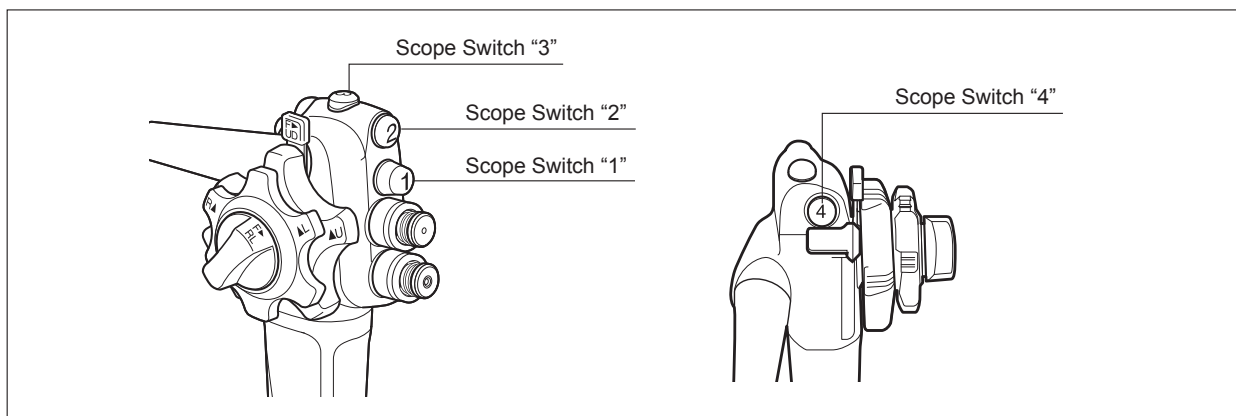

Note Use the processor to assign functions on each scope switch. For details, see the operation manual of the processor.

- (1) When a scope switch is pressed, the function assigned to the switch is activated.

5.2.4 Bending Operation

WARNING

- Do not forcibly turn the angulation knob further after turning the knob until it stops. If the angulation knob is forcibly turned, the angulation mechanism may malfunction and the bending section may not return to its neutral position, making it difficult to withdraw the endoscope.
- If the bending section does not return to its neutral position during a procedure, do not withdraw the endoscope forcibly. Consult your local FUJIFILM dealer. If the endoscope is withdrawn forcibly, injury to tissues in the body cavity, bleeding and/or perforation may result.
- Be extremely careful when performing retroflexed observation in a narrow lumen. Do not perform retroflexed observation forcibly. Otherwise, it may become impossible to straighten the angle of the bending section and/or withdraw the endoscope from the patient.

CAUTION

- Avoid forcible or excessive angulation as this may impose a severely heavy load on the wire controlling the bending section. This may cause stretching or tearing of the wire.

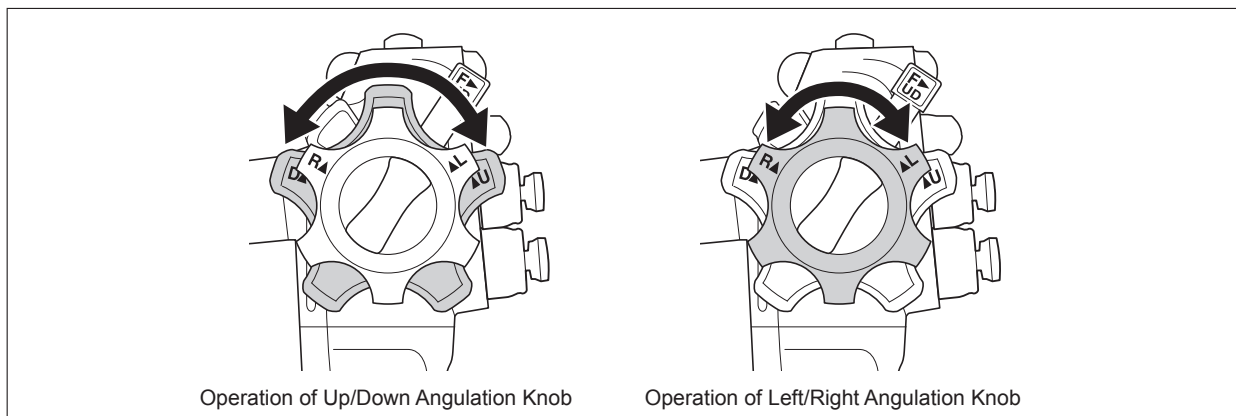

- (1) Steer the distal end of the endoscope to the region of interest by turning the up/down and left/right angulation knobs.

Note To retain the bending angle securely, hold the up/down and left/right angulation knobs by hand. When the up/down and left/right angulation knobs are not held, even if the up/down and left/right angulation knobs are locked with the up/down and left/right angulation locks, the bending angle at the distal end may change due to advancement or withdrawal of the endoscope or insertion of an endotherapy device into the instrument channel.

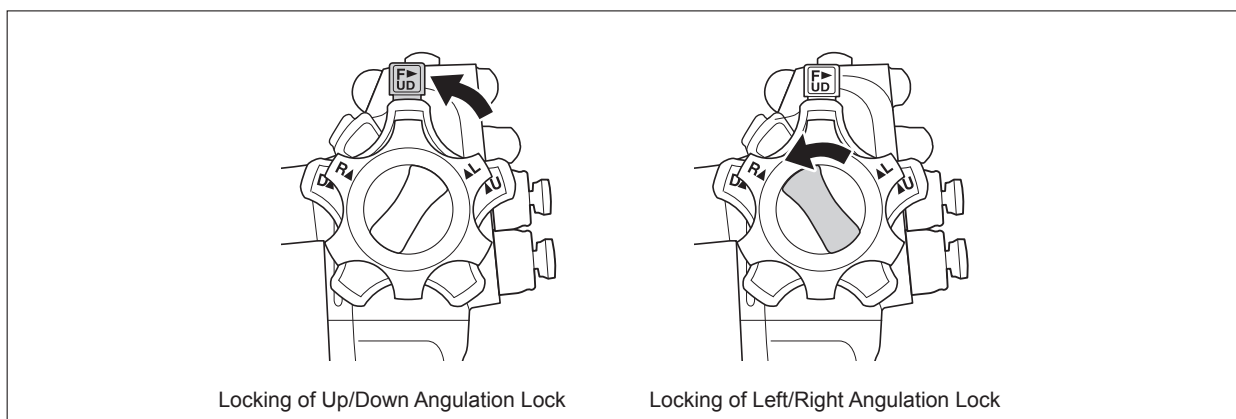

- (2) When necessary, retain the bending angle of the distal end by moving the up/down and left/right angulation locks in the opposite direction of F (Free).

Note When moving the up/down and left/right angulation locks, hold the up/down and left/right angulation knobs by hand. When the up/down and left/right angulation knobs are not held, the bending angle at the distal end may change.

5.2.5 Operating Air/Water Valve

Operate the air/water valve to supply air or water from the air/water nozzle in the distal end during a procedure.

Note Do not operate the air/water valve under the following conditions while the endoscope is inserted in the body cavity. Doing so may cause the backflow of body fluid and contaminate the sterile water in the water tank.

- The air supply pump of the light source is set to "OFF".
- The connector of the water tank is not attached to the water supply connector of the endoscope.
- The video connector of the endoscope is not connected to the scope connector socket of the processor.

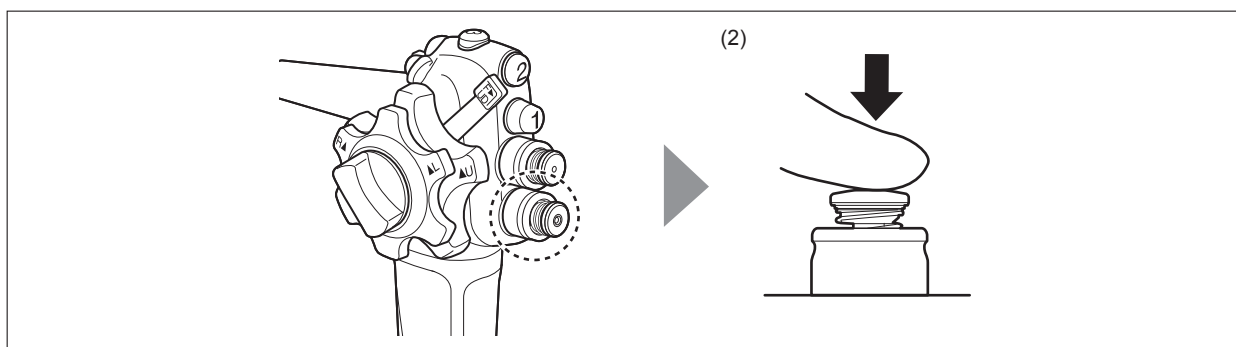

- (1) When the hole in the air/water valve is covered with one's finger, air is supplied to the air/water nozzle in the distal end.
- (2) When the air/water valve is pressed, water is supplied to the air/water nozzle in the distal end.

- Note**
- If patient material adheres to the distal objective lens or if the image is obscured, clean the surface of the lens by operating the air/water valve and supplying water.
 - If any debris such as mucus is left adhered, or if air is supplied without supplying water, the debris may become hard to remove due to drying or fixation.
 - After operating the air/water valve, if the endoscopic image is unclear due to the light reflected off the water droplets remaining on the objective lens or distal cap, it may be improved by performing suction.

5.2.6 Operating Suction Valve

WARNING

- Set the suction pressure between 40 and 53 kPa. If the suction pressure is too high, patient debris or fluids may leak or splash from the forceps valve, posing infection control risks to patient or operator.
- Do not quickly release one's finger from the suction valve during aspiration. Doing so may cause a splattering of body fluids from the suction valve and increase a risk of infection.
- The lid of the forceps valve must be closed when using the endoscope. Not doing so may cause leak of body fluids and increase a risk of infection.
- Avoid aspirating solid materials or thick fluids. If the suction valve does not return to its original position, stop aspiration immediately and slowly withdraw the endoscope. If any solid materials or thick fluids adhere to or clog the suction valve, suction may not stop, causing damage to mucous membrane.

CAUTION

- Set the suction pressure between 40 and 53 kPa. If the suction pressure is too high, the endoscope may adhere to mucous membrane, resulting in damage to the mucous membrane.
- The lid of the forceps valve must be closed when using the endoscope. Not doing so can reduce the efficacy of the endoscope's suction system, making it impossible to perform aspiration.

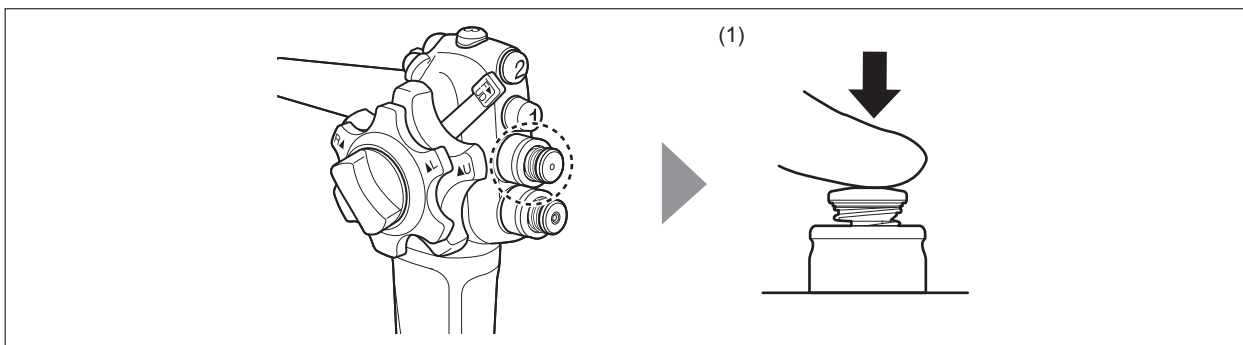

- (1) Press the suction valve to aspirate fluids in the body cavity or patient materials adhering to the distal end from the instrument channel outlet.

5.3 Injecting Fluids from Instrument Channel Inlet

WARNING

- When injecting fluids by attaching a syringe to the forceps valve, open the lid of the forceps valve and insert the syringe straight into the forceps valve. Otherwise, the forceps valve may be damaged or the syringe may be accidentally detached during fluid injection and body fluids may leak or splash from the forceps valve, posing an infection control risk to the patient or end-user.
- When the lid of the forceps valve needs to be opened during a procedure, place a piece of gauze, etc. over it to prevent leakage. Otherwise, body fluids may leak or splash from the forceps valve, posing an infection control risk to the patient or end-user.

Note The lid of the forceps valve should normally be kept closed. When attaching the syringe to supply water or fluid, remove this lid.

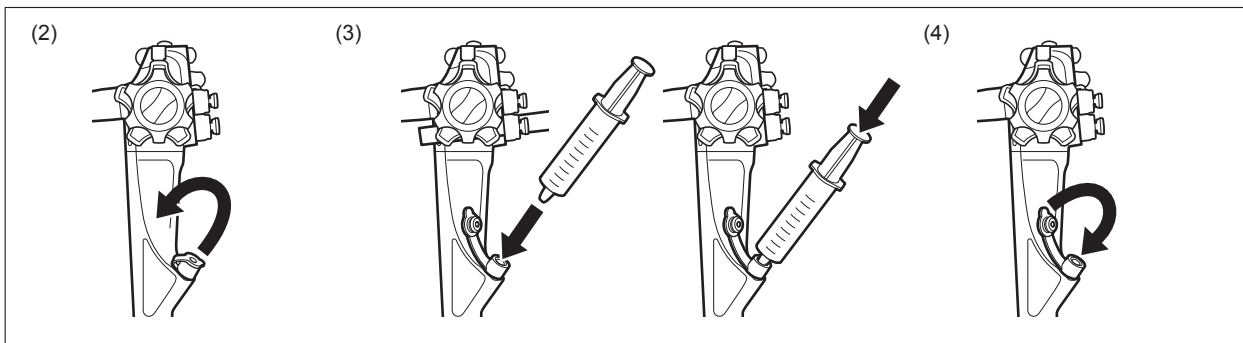

- (1) Fill a syringe with water or fluid.
- (2) Open the lid of the forceps valve.
- (3) Attach the syringe straight to the forceps valve and inject water or fluid.
- (4) Detach the syringe from the forceps valve and close the lid of the forceps valve.

5.4 ERCP

WARNING

- Do not strongly press the cannulation tube against tissues in the body cavity. Otherwise, injury to tissues in the body cavity, bleeding and/or perforation may result.

CAUTION

- Insert the cannulation tube slowly. The cannulation tube may bend if it is inserted quickly.

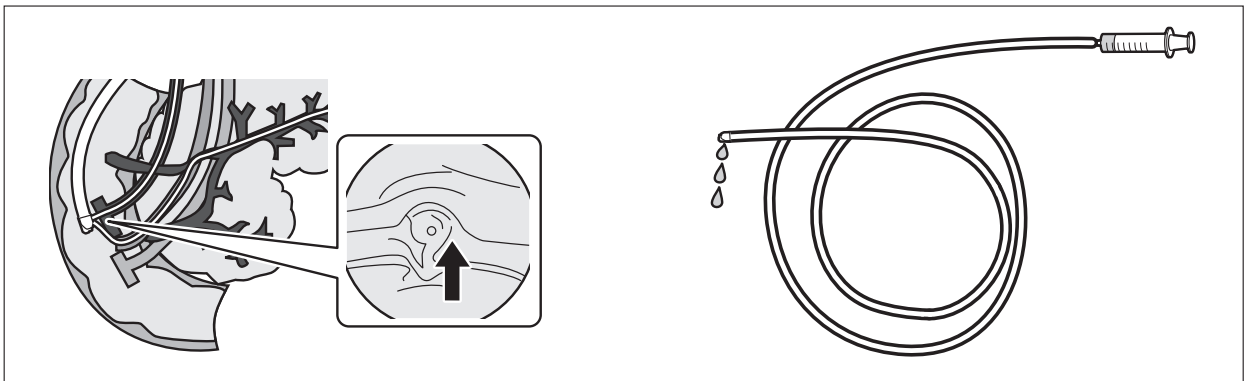

- (1) Angulate the bending section so that the duodenal papilla aperture comes to the center of the field of view.
- (2) Connect a sterile syringe filled with contrast agent to the inlet of the cannulation tube. Check that the contrast agent comes out the distal tip of the tube (cannula) when the plunger on the syringe is pressed.

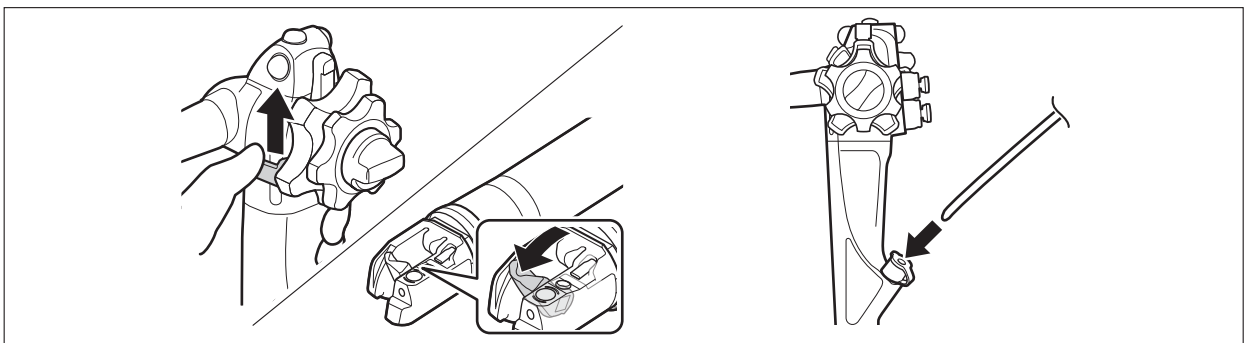

- (3) Lower the forceps elevator and insert the cannulation tube into the instrument channel inlet.

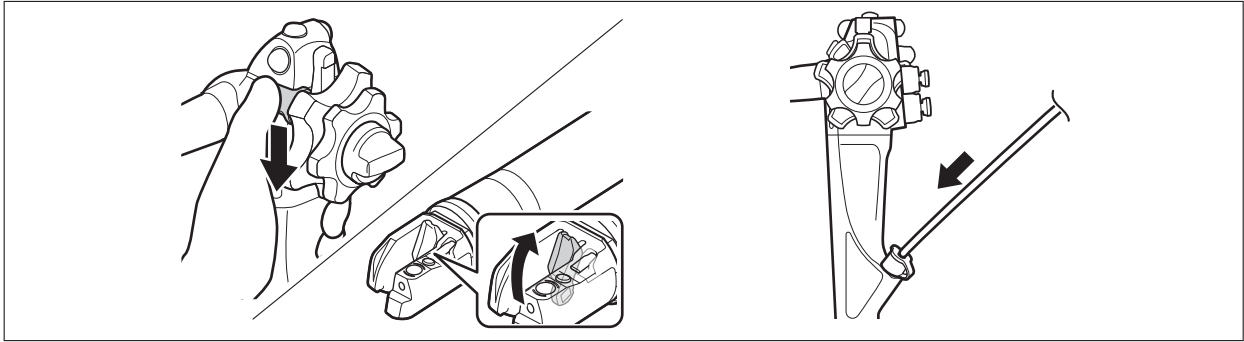

- (4) When the cannulation tube is advanced and contacts the forceps elevator and is unable to advance any further, slowly raise the forceps elevator lever and insert the cannulation tube by approximately 30mm.

Note When the forceps elevator lever is slowly raised, the tip of the cannulation tube comes into the field of view from the right lower portion of the screen.

- (5) Consistent with clinical training, direct the tip of the cannulation tube to the papilla opening and insert the cannulation tube into the common bile duct or the pancreatic duct through the papilla opening.

Note To move the tip of the cannulation tube to the papilla opening, advance and withdraw the cannulation tube by operating the angulation knobs and the forceps elevator lever.

- (6) Inject a small amount of contrast agent with a syringe and check that the cannulation tube has been inserted into the intended common bile duct or pancreatic duct.
- (7) Slowly inject the contrast agent.
- (8) Observe the conditions of the common bile duct or the pancreatic duct under fluoroscopy.

5.5 Treatment

Prior to performing endoscopic electrosurgery, one should have a thorough understanding of the manufacturers' instructions for all equipment involved and one should be familiar with the specific safety and usage aspects of each endotherapy device.

5.5.1 Using Endotherapy Devices

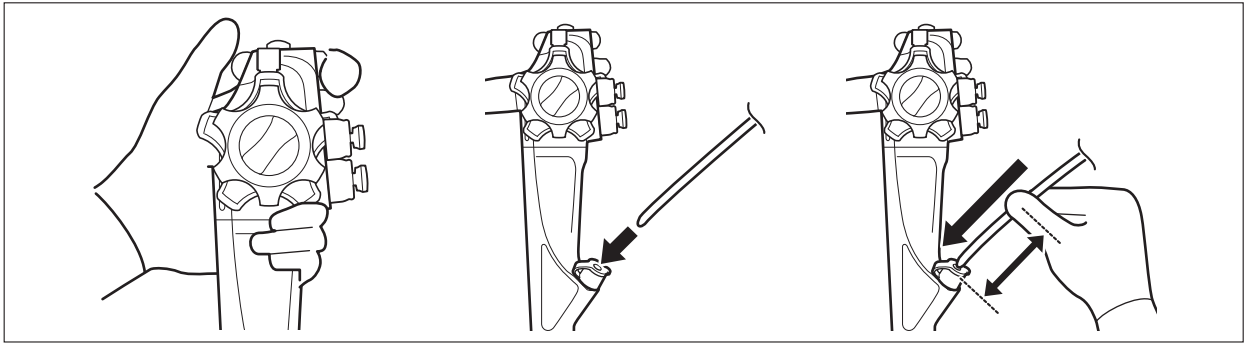

WARNING

- Use sterile or reprocessed endotherapy devices. Non-sterile or inadequately reprocessed endotherapy devices may pose an infection risk.
- Do not use endotherapy devices, operate, insert or withdraw the endoscope, perform bending, air supply or suction, or operate the related equipment whenever the endoscopic image is compromised, unclear, blurry, etc. due to any reason or condition including loss of image, power interruption, water droplets or dirt/debris adhering to the objective lens, etc. Doing so may cause injury to tissues in the body cavity, bleeding and/or perforation.
- Do not apply excessive force of the endoscope or endotherapy device against mucosal surfaces. Doing so may cause injury to tissues in the body cavity, bleeding and/or perforation.
- When inserting an endotherapy device into the endoscope, or when injecting fluids by attaching a syringe to the instrument channel inlet, slowly insert the endotherapy device or syringe straight into the endoscope. Also, when withdrawing it, slowly pull straight out. If an endotherapy device or syringe is inserted or withdrawn quickly, or if it is inserted or withdrawn obliquely against the forceps valve, the forceps valve may be damaged or accidentally detached, or a clearance may be generated between the lid and the main body of the forceps valve. As a result, body fluid may be splattered around leading to infection to the patient or end-user.
- Do not perform a procedure with an endotherapy device hung over the forceps valve. Doing so may cause leakage of body fluids and increase a risk of infection.
- Do not bend or insert the endoscope while an endotherapy device protrudes from the distal end. Excessive force of the endotherapy device may be unintentionally applied against mucosal surfaces, causing injury to tissues in the body cavity, bleeding and/or perforation.

CAUTION

- If resistance is encountered while advancing an endotherapy device within the instrument channel, do not forcibly advance the endotherapy device. Otherwise, it may cause malfunction of the endoscope.
- When inserting an endotherapy device, close the lid of the forceps valve. If the lid is open, it can reduce the efficacy of the endoscope's suction system, making it impossible to perform aspiration.

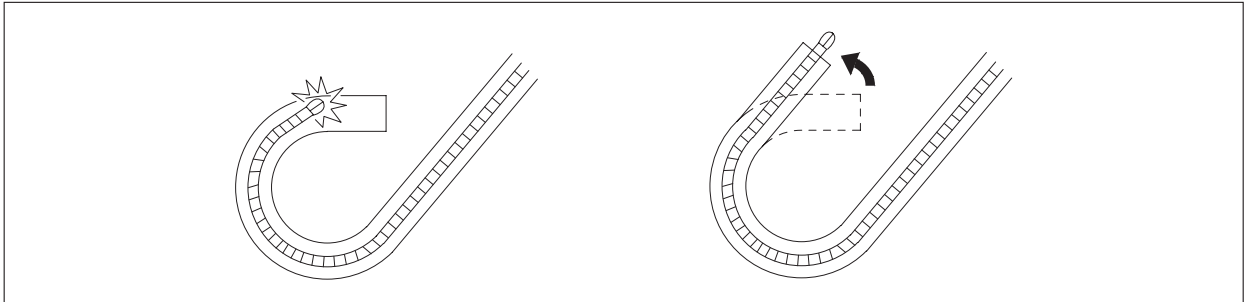

- Note**
- Occasionally, an endotherapy device can encounter difficulty while attempting to pass through an angulated bending section. In such case, reduce the angulation in the bending section a little and try to advance the endotherapy device again.
 - If the handle of an endotherapy device is held tightly, the endotherapy device may not be inserted smoothly or the maximum bending angle may decrease. If this happens, decrease the holding force.
 - If an accessory cannot be advanced or meets resistance at the scope distal tip, make sure that the forceps elevator is lowered so as not to impede or restrict movement of the accessory.

For information on handling an endotherapy device, refer to the manual of the endotherapy device. Use an endotherapy device given in this manual.

→ “Appendix - Related Equipment Used in Combination”

- Note**
- Do not open the distal end of an endotherapy device with a distal opening/closing function while it is being inserted into the endoscope.
 - Do not insert an endotherapy device with a distal needle into the endoscope while the needle is protruding from the distal end.
 - Do not protrude the needle of an endotherapy device with a distal needle while it is being inserted into the endoscope.
 - Do not detach the stopper of a clip before or while a detainment endotherapy device is being inserted into the endoscope.
 - Do not open the clip while a detainment endotherapy device is being inserted into the endoscope.

5.5.2 Use of Non-Flammable Gases

If the intestines contain a flammable gas, replace it with air or a non-flammable gas such as air or CO₂ before performing high-frequency treatment.

WARNING

- If the intestines contain a flammable gas, replace it with air or a non-flammable gas such as air or CO₂ before performing high-frequency treatment. Performing high-frequency treatment while the intestines are filled with a flammable gas could result in an explosion and/or fire.

Note When using the endoscopic CO₂ regulator, refer to the operation manual of the endoscopic CO₂ regulator.

5.5.3 High-Frequency Treatment

If the intestines contain a flammable gas, replace it with air or a non-flammable gas such as air or CO₂ before performing high-frequency treatment.

WARNING

- This product is not intended for use with the laser cauterization system. Do not use this product in combination with the laser cauterization system.
- Set the minimum required output power of the electrosurgical unit and high-frequency endotherapy device within the specified output range as per instructions provided in the operation manual of the electrosurgical unit and high-frequency endotherapy device. If the output power is inappropriate, it may cause injury to tissues in the body cavity, thermal injury, bleeding or perforation.
- Wear chemical-resistant and waterproof gloves when performing high-frequency treatment. If not worn, there is a risk of thermal injury or electric shock.
- Always keep pacemaker users away from the electrosurgical unit. The pacemaker may malfunction.
- When performing high-frequency treatment, maintain enough distance between the distal end of endoscope and the tip of the electrosurgical unit. Energize the electrosurgical unit after bringing the tip of the endotherapy device into the field of view. When the high-frequency endotherapy device or energizing part makes contact with the distal end of the endoscope, do not energize the electrosurgical unit. When performing high-frequency treatment, suck mucus adhering to the tissues in the body cavity first and then energize the electrosurgical unit. If the unit is energized when the endotherapy device in contact with the distal end of the endoscope or mucus, it may cause thermal injury.
- Before performing high-frequency treatment, basic in vitro experiments must be performed sufficiently by the user to acquire proper skills for high-frequency treatment.

WARNING

- Use an electro-surgical unit conforming to EN 60601-2-2 (IEC 60601-2-2). If any other electro-surgical unit is used, it may cause severe harm to patient and/or end-users.
- Use the electro-surgical unit and related endotherapy devices per instructions provided in the operation manual for each respective device. Otherwise, device failure, electric shock and/or burns may occur.
- Prior to performing endoscopic electro-surgery, one should have a thorough understanding of the manufacturers' instructions for all equipment involved and one should be familiar with the specific safety and usage aspects of each endotherapy device.

CAUTION

- Prevent patient's body from touching electric conductor such as metal part of bed while performing high-frequency treatment. It could cause thermal injury to a patient due to energization via the conductive part.
- When performing high-frequency treatment, take care that patient's vomitus or body fluids do not make contact with the conductive parts such as a metal part of the bed. It could cause thermal injury to a patient due to energization via vomitus or body fluids.
- While performing high-frequency treatment, ensure that the end-user does not touch the patient. It could cause thermal injury to a patient and/or end-user.
- Operate the electro-surgical unit within specified output range as per instructions provided in the operation manual of the electro-surgical unit. Leakage current may cause thermal injury.
- Do not energize the electro-surgical unit when the high-frequency endotherapy device or electrically active portion is in contact with the distal end of endoscope. Thermal injury to a patient or endoscope failure may occur.
- Do not apply the current under the circumstance that patient's clothing is wet when performing high-frequency treatment. Doing so may cause thermal injury.

- (1) Prepare, inspect and connect the electro-surgical unit and high-frequency endotherapy device as per instructions provided in respective manuals.
- (2) Perform high-frequency treatment as per instructions provided in the manual of the electro-surgical unit and high-frequency endotherapy device.

5.6 Endoscope Withdrawal

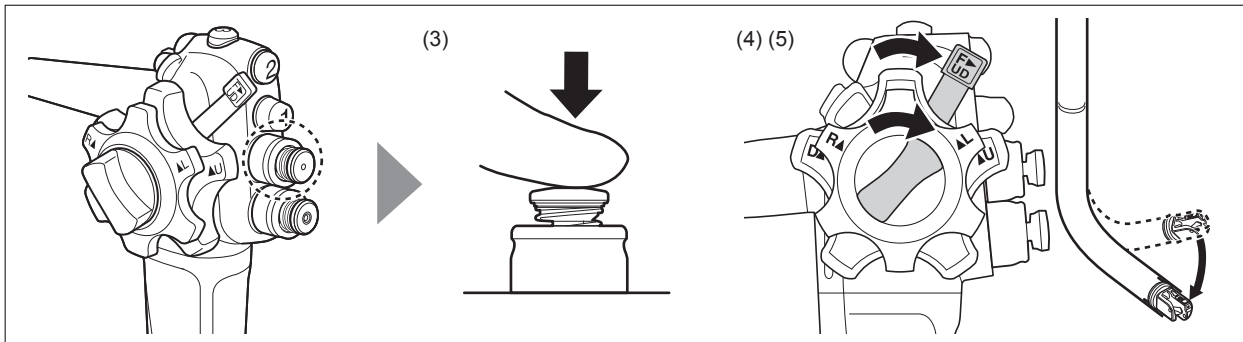

WARNING

- Unless the endoscope's bending section is in a neutral position (essentially "straight"), do not withdraw the endoscope whenever the endoscopic image is compromised, unclear, blurry, etc. due to any reason or condition including loss of image, power interruption, water droplets or dirt/debris adhering to the objective lens, etc. Doing so may cause injury to tissues in the body cavity, bleeding and/or perforation.

CAUTION

- Lower the forceps elevator before withdrawing the endoscope. Not doing so may cause patient injury.

- (1) Prior to withdrawal, press the suction valve to apply suction to remove insufflated air (or CO₂ gas) from the body.
- (2) Raise the forceps elevator lever to lower the forceps elevator.
- (3) Prior to withdrawal, operate the up/down and left/right angulation locks in the direction of F (Free) until they stop.
- (4) Prior to withdrawal, operate the up/down and left/right angulation knobs to straighten the bending section to its neutral position.
- (5) Slowly withdraw the endoscope under constant visualization.
- (6) Turn off the light of the light source.

5.7 Detaching Distal End Cap

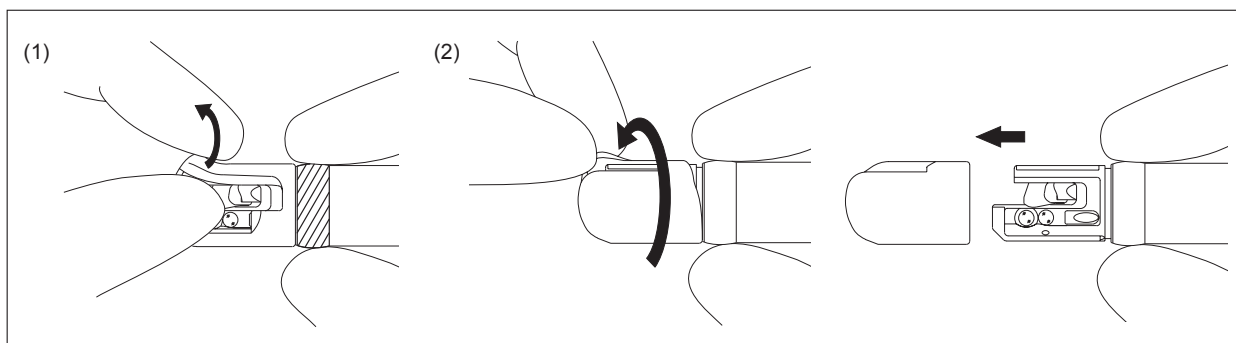

WARNING

- Unless the endoscope's bending section is in a neutral position (essentially "straight"), do not withdraw the endoscope whenever the endoscopic image is compromised, unclear, blurry, etc. due to any reason or condition including loss of image, power interruption, water droplets or dirt/debris adhering to the objective lens, etc. Doing so may cause injury to tissues in the body cavity, bleeding and/or perforation.

- (1) While holding the bending section (hard portion), twist a portion of distal end cap near the instrument channel outlet.
- (2) While twisting the distal end cap counterclockwise, pull it straight out.

5.8 Reprocessing Endoscope

After withdrawing the endoscope and discarding single-use components/accessories consistent with manufacturers' recommendations, reprocess the endoscope and its accessories as per instructions provided in the Reprocessing Manual.

→ Reprocessing Manual

WARNING

- Immediately upon completion of the procedure, it is imperative that pre-cleaning is performed as per instructions provided in the Reprocessing Manual. Otherwise, residual organic debris may begin to dry and solidify and hinder effective removal and reprocessing, causing infection.

Chapter 6 Troubleshooting

This chapter describes actions which should be taken if problems or questions occur while inspecting or using the endoscope.

If any abnormality is found during inspection, take appropriate measures by following the instructions described in “6.1 Troubleshooting.”

If the problem persists even after following troubleshooting chart in “6.1 Troubleshooting”, consult your local FUJIFILM dealer and return the product for evaluation and/or repair according to “6.4 Returning Endoscope for Repair.”

If any abnormality occurs during a procedure, immediately stop using the product and withdraw the endoscope from the patient according to “6.2 Withdrawal of Endoscope with Abnormality.”

WARNING

- Make sure to inspect the endoscope and accessories before use according to the procedures provided in this manual. Do not use the equipment that shows any signs of abnormality or irregularity. Use of abnormal equipment may lead to misdiagnosis or increase risks to patient safety.
- If any abnormality occurs during use, carry out safety checks such as checking the patient's condition and discontinue use immediately. Not doing so may seriously affect patient safety.

Note Accessories including but not limited to air/water valves, suction valves, forceps valves, cleaning brushes, cleaning adapters, distal caps, etc. are consumable items. If any deterioration or abnormality is found in accessories, they need to be replaced. Accessories cannot be repaired or refurbished. Thus, if any abnormality is found, replace with a new one.

6.1 Troubleshooting

6.1.1 Problem with Displayed Images

Problem	Cause	Remedy
No images	The cart, monitor, processor or light source is unplugged from the outlet.	Plug the cart, monitor, processor or light source into the main outlet.
	The cart, monitor, processor or light source is OFF.	Power ON the cart, monitor, processor or light source.
	The endoscope is not connected correctly to the light source.	Connect the endoscope properly to the light source. → “4.6 Connecting Endoscope to Light Source, Processor and Related Equipment”
Dark image *1	The endoscope is not connected to the light source correctly.	Connect the endoscope to the light source correctly. → “4.6 Connecting Endoscope to Light Source, Processor and Related Equipment”
	The brightness level is set around “MIN.”	Set the brightness level around 0. → Operation manual of the light source
	The iris mode is set to “PEAK.”	Set iris mode to “AVE.” → Operation manual of the processor
	Moisture or foreign matter (such as dust, gauze fibers, metallic fragments) adheres to the light guide cover glass of the LG connector.	Wipe off foreign matter on the light guide cover glass of the LG connector.
	Moisture or foreign matter (such as dust, gauze fibers, metallic fragments) adheres to the objective lens or light guide.	Wipe off foreign matter on the objective lens or light guides with soft, sterile gauze moistened with alcohol.
Halation	The brightness level is set around “MAX.”	Set the brightness level around 0. → Operation manual of the light source
	The iris mode is set to “AVE.”	Set iris mode to “PEAK.” → Operation manual of the processor

*1 When argon plasma coagulation (APC) is performed, some areas in the live image may become dark due to luminous beam of argon plasma.

Problem	Cause	Remedy
Distorted image	High-frequency interference.	Stop power supply to the high-frequency endotherapy device to restore image output. The endoscope is working properly.
	The endoscope is not connected correctly to the light source.	Connect the endoscope properly to the light source. → "4.6 Connecting Endoscope to Light Source, Processor and Related Equipment"

6.1.2 Problem with Scope Switch

Problem	Cause	Remedy
The intended function is not executed even if the scope switch is pressed.	The intended function is not assigned to the scope switch.	Assign the function to the scope switch as per instructions provided in the Operation Manual of the processor. → Operation Manual of the processor

6.1.3 Problem with Bending Section

Problem	Cause	Remedy
Bending section cannot return to neutral position.	The up/down and left/right angulation knobs are locked.	Turn the up/down and left/right angulation locks in the direction of F (Free) until they stop to unlock the up/down and left/right angulation knobs.

6.1.4 Problem with Air/Water Supply

Problem	Cause	Remedy
No air/water supply	The operation of the air pump in the light source is set to off.	Select the operation of the air pump from among "HI", "MID" and "LOW" by following the instructions described in the operation manual of the light source. → Operation manual of the light source
	The air/water valve has an abnormality.	Replace with a new reprocessed air/water valve.
	The air/water valve is not pressed firmly when supplying water.	Press the air/water valve firmly.
	Water tank cap is loose.	Close the cap firmly.
	Water tank is filled with too much sterile water.	Reduce the water level in the water tank to about 80% of its capacity.
	Water tank is empty.	Fill the water tank with sterile water.
	Water tank is not connected.	Connect the water tank.
	Clogged air/water nozzle or air/water channel.	Reprocess the air/water nozzle or air/water channel according to the instructions given in the Reprocessing Manual.
Low air/water supply amount	Foreign matters have adhered to the air/water channel.	Reprocess the air/water channel according to the instructions given in the Reprocessing Manual.
Air/water supply does not stop.	Foreign matters have adhered to the air/water valve.	Reprocess the air/water valve according to the instructions given in the Reprocessing Manual.
	The air/water valve is damaged.	Replace with a new air/water valve.
	The air/water valve has been degraded.	Replace with a new air/water valve.
Operation of the air/water valve is heavy.	The friction resistance between the air/water valve and the air/water valve cylinder has increased.	Detach the air/water valve and moisten the rubber seal with sterile water.

6.1.5 Problem with Suction

Problem	Cause	Remedy
No suction	Suction unit is switched off.	Switch on the suction unit.
	Suction unit is not connected.	Connect the suction unit.
	No forceps valve is attached.	Attach a forceps valve.

Problem	Cause	Remedy
Low suction volume	The suction valve has been damaged.	Replace with a new reprocessed suction valve.
	The forceps valve has been damaged.	Replace with a new forceps valve.
	The suction tube is not attached properly.	Reattach the suction tube.
	The forceps valve is not attached properly.	Attach the forceps valve properly and close the lid.
Suction valve does not return to the original position.	Solid materials or thick fluids have adhered to the suction valve.	Detach the suction tube from the suction unit. Detach the suction valve and replace with a new reprocessed suction valve.
	Suction valve is damaged.	Replace with a new suction valve.
Suction valve cannot be detached.	The suction valve or the control portion of the endoscope has been damaged.	Contact your local FUJIFILM dealer.
Fluid leaks from forceps valve during suction.	The forceps valve is not attached correctly.	Attach the forceps valve properly and close the lid.
	The forceps valve is damaged.	Replace with a new forceps valve.

6.1.6 Problem with Related Equipment

◆ Problem with Endotherapy Devices

Problem	Cause	Remedy
Endotherapy device cannot be inserted.	The endotherapy device (such as biopsy forceps) is left open.	Close the endotherapy device for insertion.
	The handle of endotherapy device (such as biopsy forceps) is held firmly.	Loosen the grip to insert the endotherapy device.
	The endotherapy device has difficulty being inserted due to bending.	Reduce the angle of the bending section slightly and then insert it.
	The endotherapy device has an abnormality.	Withdraw the endotherapy device and replace it with a new one.
	An endotherapy device which is not compatible with this product is used.	Use an endotherapy device compatible with this product.

Problem	Cause	Remedy
Endotherapy device cannot be withdrawn.	The endotherapy device (such as biopsy forceps) is left open.	Close the endotherapy device and pull it out from the endoscope.
	The handle of the endotherapy device (such as biopsy forceps) is held firmly.	Loosen the grip and pull out the endotherapy device from the endoscope.
	The endotherapy device has difficulty being pulled out due to bending.	Reduce the angle of the bending section slightly and then pull out the endotherapy device from the endoscope.
	An abnormality occurs in the endotherapy device.	Withdraw the tip of the endotherapy device to the instrument channel outlet of the endoscope, and then slowly pull out the endoscope and endotherapy device together.
	An endotherapy device which is not compatible with this product is used.	Withdraw the tip of the endotherapy device to the instrument channel outlet of the endoscope, and then slowly pull out the endoscope and endotherapy device together.

◆ Problem with Image Recorder

Problem	Cause	Remedy
Images cannot be captured on image recorder.	Image recorder is not connected.	Connect the image recorder.
	Image recorder is not connected properly.	Connect the image recorder correctly.

6.2 Withdrawal of Endoscope with Abnormality

When the endoscope needs to be withdrawn due to an abnormality during a procedure, take appropriate measures as described in either “6.2.1 When Endoscopic Images Appear on the Monitor” or “6.2.2 When Endoscopic Images Do Not Appear on the Monitor or a Frozen Image Cannot be Restored.”

If abnormalities of the withdrawn endoscope are not described in “6.3 Handling of Endoscope with Abnormality”, contact your local FUJIFILM dealer and return the endoscope for repair as described in “6.4 Returning Endoscope for Repair.”

In addition, if the endoscope cannot be withdrawn smoothly, do not withdraw the endoscope forcibly and consult your local FUJIFILM dealer.

WARNING

- If an abnormality occurs during a treatment, stop the treatment immediately and slowly pull out the endotherapy device from the endoscope. If the endotherapy device cannot be pulled out from the endoscope, withdraw the tip of the endotherapy device to the instrument channel outlet of the endoscope, and then slowly pull out the endoscope and endotherapy device together. If the treatment is not stopped or the endotherapy device is forcibly pulled out, it may cause injury to tissues in the patient’s body cavity, bleeding and/or perforation.
- During a procedure, if any abnormality (loss of image, dark image, bright image, etc.) is found in the endoscopic image, the imaging section may malfunction. If this happens, stop the treatment immediately and slowly pull out the endoscope. If the endoscope is used as it is, it may cause overheating of the distal end, possibly resulting in mucosal burns or other injury.

Note Use spare or back-up equipment to complete the procedure as necessary.

6.2.1 When Endoscopic Images Appear on the Monitor

- (1) Turn off all related equipment except the processor, light source, monitor, and suction pump.
- (2) When using an endotherapy device, slowly withdraw the endotherapy device from the endoscope.
- (3) Aspirate accumulated air (or CO₂ gas) by pressing the suction valve.
- (4) Turn the up/down and left/right angulation locks in the direction of F (Free) until they stop to unlock the up/down and left/right angulation knobs.
- (5) Operate the up/down and left/right angulation knobs to straighten the bending section before withdrawing the endoscope.
- (6) Slowly withdraw the endoscope.

6.2.2 When Endoscopic Images Do Not Appear on the Monitor or a Frozen Image Cannot be Restored

- (1) Turn off the processor, light source, monitor, suction pump and other related equipment.
- (2) When using an endotherapy device, slowly withdraw the endotherapy device from the endoscope.
- (3) Turn the up/down and left/right angulation locks in the direction of F (Free) until they stop to unlock the up/down and left/right angulation knobs.
- (4) Operate the up/down and left/right angulation knobs to straighten the bending section and release one's hand from the up/down and left/right angulation knobs.
- (5) Slowly withdraw the endoscope.

6.3 Handling of Endoscope with Abnormality

If the problem persists even after following “6.3.1 When Suction Valve Does Not Return to Its Original Position”, contact your local FUJIFILM dealer.

6.3.1 When Suction Valve Does Not Return to Its Original Position

WARNING

- If it is necessary to supply air or water from the suction connector when an abnormality is found in the suction valve during a procedure, do so while pressing the suction valve. If air or water is supplied without pressing the suction valve, body fluids may leak or splash from the suction valve, posing an infection control risk.

- (1) Turn off all related equipment except the processor, light source, monitor, and suction pump.
- (2) Raise the forceps elevator lever to lower the forceps elevator.
- (3) When using an endotherapy device, slowly withdraw the endotherapy device from the endoscope.
- (4) Aspirate accumulated air (or CO₂ gas) by pressing the suction valve.
- (5) Turn off the suction pump.
- (6) Turn the up/down and left/right angulation locks in the direction of F (Free) until they stop to unlock the up/down and left/right angulation knobs.
- (7) Operate the up/down and left/right angulation knobs to straighten the bending section before withdrawing the endoscope.
- (8) Slowly withdraw the endoscope.
- (9) Prepare the reprocessed injection tube and two clean basins filled with sterile water.
- (10) Straighten the insertion portion of the endoscope, and immerse the distal end in a clean basin filled with sterile water.
- (11) Disconnect the suction tube from the suction connector on the LG connector.
- (12) Attach the tube for instrument/suction channel of the injection tube to the suction connector on the LG connector.
- (13) Immerse the weight of the injection tube in the other clean basin filled with sterile water.

- (14) Attach a sterile syringe to the suction channel side of the injection tube and aspirate sterile water with the syringe. While pressing the suction valve, flush sterile water into the instrument/suction channel until the solid materials clogging the channel are removed.
- (15) Remove the weight of the injection tube from the clean basin filled with sterile water.
- (16) Aspirate air with the syringe. While pressing the suction valve, inject air into instrument/suction channel until the sterile water inside the channel is discharged completely.
- (17) Detach the sterile syringe from the suction channel side of the injection tube.
- (18) Detach the tube for instrument/suction channel of the injection tube from the suction connector on the LG connector.
- (19) Inspect the endoscope to check that it is free from abnormalities.

→ “Chapter 4 Preparation and Inspection”

6.4 Returning Endoscope for Repair

When returning the endoscope, provide a detailed description of the concern, malfunction or device failure.

→ “Chapter 7 Service”

WARNING

- Contact your local FUJIFILM dealer when this product is returned for repair. Be sure to reprocess this product before returning for repair. If a product which is not reprocessed is returned, it can create a risk of infection to users, service personnel or other persons in contact with it.

CAUTION

- When transporting the endoscope to the outside of the hospital, store the endoscope in a FUJIFILM-specified carrying case. Not doing so may cause product failure.

Chapter 7 Service

This chapter explains the services regarding this product.

7.1 Service

If this product does not work properly, check it first by reading this manual again and follow all instructions and troubleshooting tips.

If this product is still not working well, contact your local FUJIFILM dealer.

7.2 After-Sales Service

Contact your local FUJIFILM dealer when this product is returned for repair.

Be sure to clean and disinfect (or sterilize) this product before returning for repair.

The product which is not cleaned and disinfected (or sterilized) may increase infection control risks to users, service personnel or other persons in contact with it.

When contacting your local FUJIFILM dealer, provide the following information.

Model name :

Serial number :

Description of failure : Provide as much details as possible:

Date of purchase :

Reprocessing method (Automated Endoscope Reprocessor, disinfectant solution, etc.):

◆ Repairs during the warranty period

This product will be repaired free of charge within warranty guidelines.

The warranty period for the endoscope, excluding accessories, is one year after date of purchase.

Note that the warranty is void in the following cases:

- Damage caused by fire or natural disaster such as storms or floods.
- Problem caused by careless handling or misuse including use of non-compatible reprocessing systems or agents.
- Malfunctions or damages due to products of other manufacturers not supplied by FUJIFILM.
- Remodeling, maintenance, and repair using repair parts other than those specified by FUJIFILM.

◆ Repairs after the warranty period

This product will be repaired with charge at your request.

Appendix

This chapter describes main specifications, related equipment used in combination with this product, electromagnetic compatibility (EMC), etc.

Main Specification

◆ Classification of Medical Electrical Equipment

1. Type of protection against electric shock:
Class I equipment (power supply: protected ground fault receptacle)
2. Degree of protection against electric shock:
Type BF applied part
3. Degree of explosion protection:
Use is prohibited in an oxygen-rich environment or in a flammable gas atmosphere.

Note Use in combination with the processor VP-7000/VP-4450HD/VP-3500HD and the light source BL-7000/XL-4450.

◆ Electromagnetic Compatibility (EMC) Related Standard

This product has been tested and confirmed to comply with the limits for medical devices defined in EN 60601-1-2:2007.

There is no guarantee that interference will not occur in a particular installation.

◆ Applied Part

Insertion portion

◆ Specifications

	ED-580XT
Optical system:	
Viewing direction	95° (retro-viewing 5°)
Field of view	100°
Observation range (mm)	4 to 60
Method of illumination	Light guide method
Image size	Semi-super image
Distal end diameter (mm)	13.1
Insertion tube diameter (mm)	11.3
Maximum diameter of insertion portion (mm)	14.9
Minimum diameter of instrument channel (mm) *1	4.2
Bending capability:	
Up/Down	120° / 90°
Left/Right	90° / 110°
Working length (mm) *2	1250
Total length (mm)	1550
Insertion route	Peroral

*1 Channel size should not be used as the sole consideration for compatibility of an accessory.

*2 Use an endotherapy device with working length of 1800 mm or longer.

Operating Environment, Transport Environment and Storage Environment

◆ Operating Environment

Temperature	+10 to +40°C
Humidity	30 to 85%RH (no dew condensation)
Pressure	70 to 106 kPa (within range of atmospheric pressure)

◆ Transport Environment

Temperature	-20 to +60°C
Humidity	10 to 85%RH (no dew condensation)
Pressure	70 to 106 kPa (within range of atmospheric pressure)

◆ Storage Environment

Temperature	-20 to +60°C
Humidity	10 to 85%RH (no dew condensation)
Pressure	70 to 106 kPa (within range of atmospheric pressure)

◆ Term of Validity/Period for Use (Durability)

The term of validity (durability) is 6 years * from first use of the endoscope, providing that the endoscope undergoes periodic servicing. "Based on our company's criteria"

* Except consumable supplies

Accessories

Accessories in the following tables are items whose life expectancy is limited and will require replacement once they show signs of wear or irregularity. Such accessories cannot be repaired or refurbished and should be replaced after any irregularity is observed.

Name	Model
Forceps valve	FOV-DV7 *1
Air/water valve	AW-603
Suction valve	SB-605
Suction channel brush	WB7025DC *1
Cylinder/inlet brush	WB11003DV *1
Distal end brush	WB1318DE *1
Cleaning adapter	CA-610
Air/water channel cleaning adapter	CA-611
Ventilation adapter	AD-7
Distal end cap	DC-07D *1

*1 Single use item, all others are reusable.

Related Equipment Used in Combination

Note In addition to the devices described here, new products that can be used in combination with this product may be added. Note that the devices described here may have already been discontinued. For details on the devices used in combination with this product, contact your local FUJIFILM dealer.

◆ Compatible Processor and Light Source

Name	Model
Processor	VP-7000 VP-4450HD VP-3500HD
Light source	BL-7000 XL-4450

Note For details on the monitors, printers and video recorders that can be used in combination with this product, refer to the operation manual of the processor and light source.

◆ Water Tank

Name	Model
Water tank	WT-2 WT-4

◆ Suction Unit

Use a suction unit which complies with EN 60601-1 (IEC 60601-1) and can set suction pressure to 40 to 53 kPa.

Note For details on the suction unit that can be used in combination with this product, refer to the operation manual of the suction unit.

◆ Endoscopic CO₂ Regulator and Accessories

Name	Model
Endoscopic CO ₂ regulator	GW-100
Water tank	WT-604G
Gas/water valve	AW-604G

◆ Electrosurgical Unit

Use an electrosurgical unit which complies with EN 60601-2-2 (IEC 60601-2-2).

Note For details on the electrosurgical unit that can be used in combination with this product, refer to the operation manual of the diathermic slitter.

◆ Air Leak Tester

Name	Model
Air leak tester	LT-7F

◆ Mouthpiece

Name	Model
Mouthpiece	MPC-ST

◆ Compatible Endotherapy Devices

Endotherapy devices have a use-by date. If any deterioration or abnormality is found in them, they need to be replaced. Endotherapy devices cannot be repaired or refurbished. Thus, if any abnormality is found, replace with a new one.

Note For details on endotherapy devices used in combination with this product, consult your local FUJIFILM dealer.

◆ Medical Device Directive

This product complies with the requirements of European Directive 93/42/EEC.
Classification : Class II a



Electromagnetic Compatibility (EMC) Information

Medical electronic equipment requires special care with regards to EMC and must be installed and used according to the EMC information provided in Table 1 through Table 4.

<Electromagnetic Emission Compliance Information and Guidance>

Table 1

Guidance and Manufacturer Declaration - Electromagnetic Emission -		
This device is intended for use in the following prescribed electromagnetic environments. Customers and users of this product are advised to check that it is being used in such environments.		
Emission standard	Compliance	Guidance
RF emissions EN 55011	Group 1	This product uses RF energy for internal functions only. Accordingly, the RF emission is very low and unlikely to cause any interference with nearby electronics.
RF emissions EN 55011	Class A	[RF emissions] This product is intended for use in medical facilities and commercial facilities. Therefore, if this product is used in domestic establishments, electromagnetic interference may occur in any devices. In this case, it is recommended to use this product according to "Chapter 1 Precautions."
Harmonic emissions EN 61000-3-2	Class A	
Voltage fluctuation/ flicker emissions EN 61000-3-3	Applicable	

<Electromagnetic Immunity Compliance Information and Guidance>

Table 2

Guidance and Manufacturer Declaration - Electromagnetic Immunity -			
This device is intended for use in the following prescribed electromagnetic environments. Customers and users of this product are advised to check that it is being used in such environments.			
Immunity test	EN 60601 test level	Compliance level	Guidance
Electrostatic discharge (ESD) EN 61000-4-2	±6kV contact ±8kV air	±2kV contact ±4kV contact ±6kV contact ±2kV air ±4kV air ±8kV air	Floors should be wood, concrete, or ceramic tile. If floors are covered with synthetic material, the relative humidity should be at least 30%.
Electrical fast transient/burst EN 61000-4-4	±2kV for power supply lines ±1kV for input/output lines	±2kV for power supply lines ±1kV for input/output lines	Main power quality should be that of a typical commercial or hospital environment.
Surge EN 61000-4-5	±1kV line to line ±2kV line to earth	±1kV line to line ±2kV line to earth	Main power quality should be that of a typical commercial or hospital environment.
Voltage dips, short interruptions and voltage variations on power supply input lines EN 61000-4-11	< 5 % U_T (dip in > 95 % U_T) for 0.5 cycles 40 % U_T (dip in 60 % U_T) for 5 cycles 70 % U_T (dip in 30 % U_T) for 25 cycles < 5 % U_T (dip in > 95 % U_T) for 5 seconds	< 5 % U_T (dip in > 95 % U_T) for 0.5 cycles 40 % U_T (dip in 60 % U_T) for 5 cycles 70 % U_T (dip in 30 % U_T) for 25 cycles < 5 % U_T (dip in > 95 % U_T) for 5 seconds	Main power quality should be that of a typical commercial or hospital environment. If the user of this product requires continued operation during power mains interruptions, it is recommended that this product is powered from an uninterruptible power supply or battery
Power frequency (50/60 Hz) magnetic field EN 61000-4-8	3 A/m	3 A/m	The power frequency magnetic field should have the same level of characteristics as a common location in standard business and hospital environments.

Note U_T is the a.c. mains voltage prior to application of the test level.

<Portable and Mobile RF Communications Equipment Compliance Information and Guidance>

Table 3

Guidance and Manufacturer Declaration - Electromagnetic Immunity -			
This device is intended for use in the following prescribed electromagnetic environments. Customers and users of this product are advised to check that it is being used in such environments.			
Immunity test	EN 60601 test level	Compliance level	Guidance
Conducted RF EN 61000-4-6	3Vrms 150kHz to 80MHz	3 Vrms	<p>Portable and mobile RF communications equipment should be used no closer to any part of this product, including cables, than the recommended separation distance calculated from the equation applicable to the frequency of the transmitter.</p> <p>Recommended separation distance $d = 1.2 \sqrt{P}$ $d = 1.2 \sqrt{P}$ 80MHz to 800MHz $d = 2.3 \sqrt{P}$ 800MHz to 2.5GHz Where "P" is the maximum output power rating of the transmitter in watts (W) according to the transmitter manufacturer and "d" is the recommended separation distance in meters (m). The electric field intensity from a fixed RF transmitter determined by an electromagnetic field study*¹ should be lower than the compliance level in each frequency range*².</p> <p>Interference may occur near devices that display the following symbol.</p> 
Radiated RF EN 61000-4-3	3V/m 80MHz to 2.5GHz	3 V/m	

*1 Electric field intensity from fixed transmitters such as wireless (mobile / cordless) telephone base stations, land mobile radio base stations, amateur radio, AM and FM radio broadcasts, and TV broadcasts cannot be predicted accurately in theory.

An electromagnetic field survey should be considered to estimate the electromagnetic environment due to fixed RF transmitters. When the measured electric field intensity in the location in which this product is used exceeds the RF compatibility level applied above, this product should be monitored to verify whether it is operating normally. When abnormal operation has been confirmed, it may be necessary to take additional measures, such as relocation or re-installation of this product.

*2 The electric field intensity should be less than 3 V/m through the frequency range from 150 kHz through 80 MHz.

- Note**
- For 80 and 800 MHz, apply the higher frequency range.
 - These guidelines do not apply to all circumstances. Electromagnetic propagation is affected by absorption and reflection by buildings, items, and people.

<Recommended Separation Distance Between Portable and Mobile RF Communications Equipment and this Product>

Table 4

Recommended separation distance for portable and mobile RF communications equipment and this equipment			
--	--	--	--

This device is intended for use in electromagnetic environments in which emission RF interference is managed.

To control electromagnetic interference, the customer and user of this product can maintain the minimum distance between the following recommended portable and mobile RF communications equipment (transmitters) and this product based on the maximum output of the transmitter.

Rated maximum output power of transmitter P (W)	Separation distance related to frequency of the transmitter (m)		
	150kHz to 80MHz $d=1.2\sqrt{P}$	80MHz to 800MHz $d=1.2\sqrt{P}$	800MHz to 2.5GHz $d=2.3\sqrt{P}$
0.01	0.12	0.12	0.23
0.1	0.38	0.38	0.73
1	1.2	1.2	2.3
10	3.8	3.8	7.3
100	12	12	23

For transmitters with a maximum output electric power rated value not listed above, the recommended separation distance (d) expressed in meters (m) can be determined using a formula that corresponds with the frequency of the transmitter. In these formulas, "P" is the maximum output power rating of the transmitter in watts (W) according to the transmitter manufacturer.

- Note**
- For 80 and 800 MHz, apply the higher frequency range for the separation distance.
 - These guidelines do not apply to all circumstances. Electromagnetic propagation is affected by absorption and reflection by buildings, items, and people.

Disposal of Electric and Electronic Equipment



Disposal of Used Electrical and Electronic Equipment (Applicable in the European Union and other European countries with separate collection systems)

This symbol on the product, or in the manual and/or on this packaging, indicates that this product shall not be treated as household waste.

Instead it should be taken to an applicable collection point for the recycling of electrical and electronic equipment.

By ensuring this product is disposed of correctly, you will help prevent potential negative consequences to the environment and human health, which could otherwise be caused by inappropriate waste handling of this product.

The recycling of materials will help to conserve natural resources. For more detailed information about recycling of this product, contact your local FUJIFILM dealer.

In Countries outside the EU: If you wish to discard this product, contact your local authorities and ask for the correct way of disposal.

Index

A

Air guide port	2-4
Air/water nozzle	2-9
Air/water valve	2-5
Air/water valve cylinder	2-5

B

Bending Section	2-5
Boot	2-5

C

Control Portion	2-5
-----------------------	-----

D

Distal end	2-5
------------------	-----

F

Forceps Elevator	2-9
Forceps Elevator Lever	2-5
Forceps Valve	2-5

I

Imaging Section	2-9
Insertion Portion (Applied Part)	2-5
Insertion Tube	2-5
Instrument Channel Inlet	2-5
Instrument Channel Outlet	2-9

L

Label for the Serial Number	2-10
Label for the Year of Manufacture	2-10
Left/Right Angulation Knob	2-5
Left/Right Angulation Lock	2-5
LG Connector	2-4
LG Connector Label	2-10
LG Flexible Portion	2-4
Light Guide Cover Glass	2-4
Light Guide Prong	2-4
Light Guides	2-9
Lock Handle	2-4

O

Objective Lens	2-9
----------------------	-----

S

S Connector	2-4
Suction Connector	2-4
Suction Valve	2-5
Suction Valve Cylinder	2-5

U

Up/Down Angulation Knob	2-5
Up/Down Angulation Lock	2-5

V

Ventilation Connector	2-4
Video Connector	2-4

W

Waterproof Cap	2-4
Water Supply Connector	2-4

Service Centers

Contact our regional representative below or the distributor from which you purchased the product.

<Europe>

FUJIFILM Europe GmbH

<http://www.fujifilm.eu/eu/>

See our website to locate our representative in your country.

<USA>

Fujifilm Medical Systems U.S.A., Inc

<http://www.fujifilmendoscopy.com/>

(800) 385-4666

<Australia>

FUJIFILM Australia Pty Ltd.

<http://www.fujifilm.com.au/>

1800 060 209

<Asia>

FUJIFILM (Singapore) Pte. Ltd.

<http://www.fujifilm.com.sg/>

6380-5540

If you are not a resident of the regions above, contact the distributor from which you purchased the product.



FUJIFILM Corporation

26-30, Nishiazabu 2-chome, Minato-ku, Tokyo 106-8620, Japan



FUJIFILM Europe GmbH

Heesenstrasse 31, 40549 Duesseldorf, Germany

EU Importer:

FUJIFILM Europe B.V.

Oudenstaart 1, 5047 TK Tilburg, The Netherlands