

Swartz™ Braided Transseptal
Guiding Introducers
SL Series
63 cm Length
8 F – 8.5 F

Access

Product Highlights

- Braided sheath facilitates torqueability, pushability and catheter stability
- Ultra-soft tip for atraumatic performance
- Multiple curve options available
- Smaller offset sideholes reduce likelihood of guidewire exiting sidehole
- Ultimum™ valve for effective hemostasis and minimal risk of air aspiration
- Accommodates a 71 cm BRK™ Transseptal Needle (Reorder Number 407200 or 407201)

Ordering Information

Swartz™ Braided SL Transseptal Guiding Introducer Sheath with Hemostasis Valve and Sideport, Dilator, and 180 cm Super Stiff Guidewire with Finger Straightenable 3 mm “J” (1 unit per box)

Reorder Number	Sheath French Size	Dilator French Size	Maximum Guidewire Diameter (in)	Curve Type	Sheath Usable Length (cm)	Dilator Usable Length (cm)
407449	8	8	.032	SL0™	63	67
407439	8	8	.032	SL1™	63	67
407441	8	8	.032	SL2™	63	67
407443	8	8	.032	SL3™	63	67
407446	8	8	.032	SL4™	63	67
407451	8.5	8.5	.032	SL0™	63	67
407453	8.5	8.5	.032	SL1™	63	67
407455	8.5	8.5	.032	SL2™	63	67
407457	8.5	8.5	.032	SL3™	63	67
407459	8.5	8.5	.032	SL4™	63	67

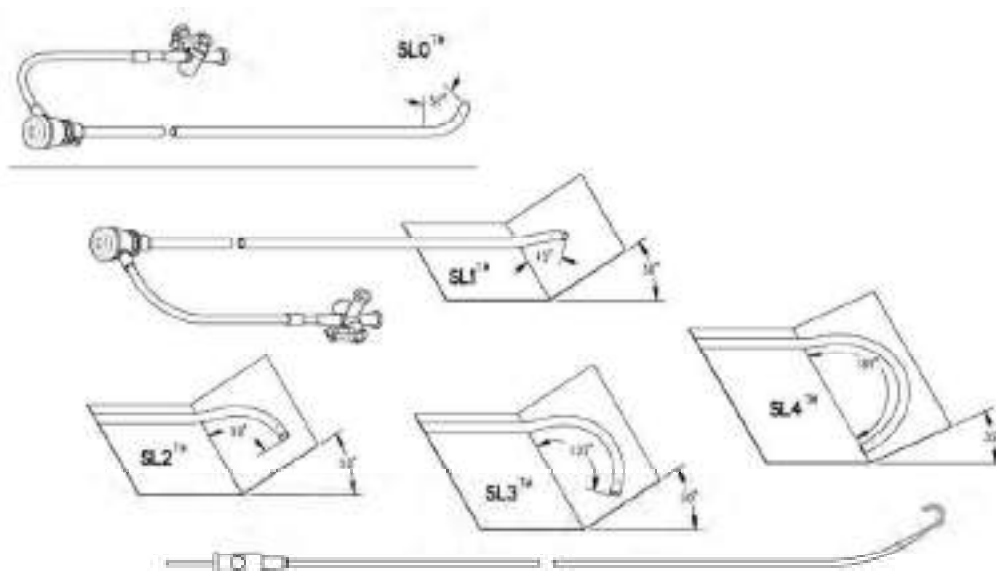

Swartz™ Braided Transseptal
Guiding Introducers
SL Series
81 cm Length
8 F–8.5 F

Access

Product Highlights

- Braided sheath facilitates torqueability, pushability and catheter stability
- Ultra-soft tip for atraumatic performance
- Multiple curve options available
- Smaller offset sideholes reduce likelihood of guidewire exiting sidehole
- Ultimium™ valve for effective hemostasis and minimal risk of air aspiration
- Accommodates an 89 cm BRK™ Transseptal Needle (Reorder Number 407205)

Ordering Information

Swartz™ Braided SL Transseptal Guiding Introducer Sheath with Hemostasis Valve and Sideport, Dilator, and 180 cm Super Stiff Guidewire with Finger Straightenable 3 mm “J” (1 unit per box)

Reorder Number	Sheath French Size	Dilator French Size	Maximum Guidewire Diameter (in)	Curve Type	Sheath Usable Length (cm)	Dilator Usable Length (cm)
407450	8	8	.032	SL0™	81	85
407440	8	8	.032	SL1™	81	85
407452	8.5	8.5	.032	SL0™	81	85
407454	8.5	8.5	.032	SL1™	81	85
407456	8.5	8.5	.032	SL2™	81	85

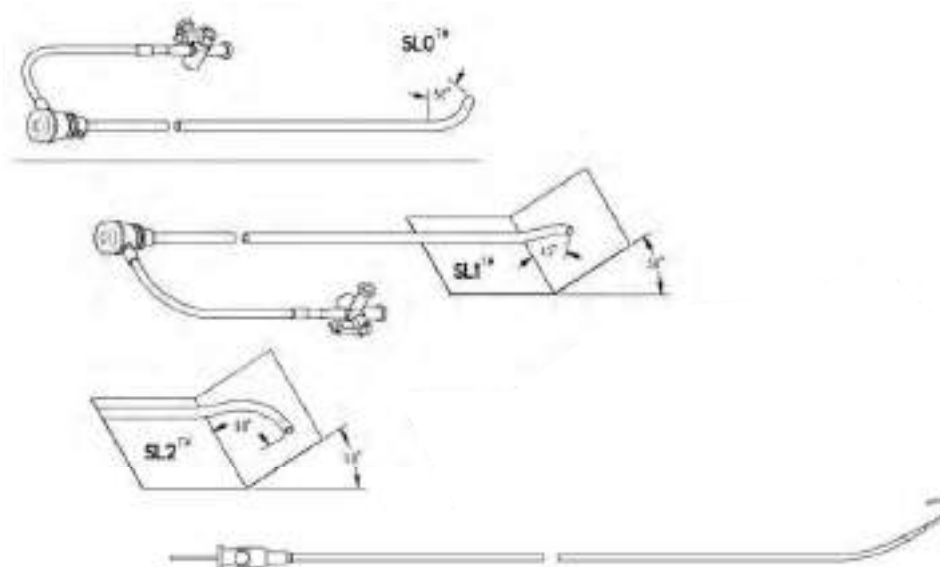

EC Design-Examination Certificate

Directive 93/42/EEC on Medical Devices, Annex II Section 4

No. CE 701340
Issued To: **Abbott Medical**
5050 Nathan Lane North
Plymouth
Minnesota
55442
USA

In respect of:

Swartz Braided Transseptal Guiding Introducers

BSI has performed a design examination on the above devices in accordance with the Council Directive 93/42/EEC, Annex II Section 4. The design conforms to the requirements of this directive. For marketing of these products an additional Annex II excluding Section 4 certificate is required.

For and on behalf of BSI, a Notified Body for the above Directive (Notified Body Number 2797):



Gary E Slack, Senior Vice President Medical Devices

First Issued: **2018-12-12**

Date: **2019-12-16**

Expiry Date: **2023-05-15**

...making excellence a habit.™

Page 1 of 3

Validity of this certificate is conditional on the quality system being maintained to the requirements of the Directive as demonstrated through the required surveillance activities of the Notified Body.
This certificate was issued electronically and is bound by the conditions of the contract.

EC Design-Examination Certificate

Supplementary Information to CE 701340

Issued To:

**Abbott Medical
5050 Nathan Lane North
Plymouth
Minnesota
55442
USA**

Swartz Braided Transseptal Guiding Introducers

Model numbers:

407356, 407357, 407358, 407359, 407360, 407362, 407363, 407364, 407365, 407366, 407367, 407439,
407440, 407441, 407442, 407443, 407445, 407446, 407448, 407449, 407450, 407451, 407452, 407453,
407454, 407455, 407456, 407457, 407459

First Issued: **2018-12-12**

Date: **2019-12-16**

Expiry Date: **2023-05-15**

...making excellence a habit.™

Page 2 of 3

Validity of this certificate is conditional on the quality system being maintained to the requirements of the Directive as demonstrated through the required surveillance activities of the Notified Body.
This certificate was issued electronically and is bound by the conditions of the contract.

EC Design-Examination Certificate

Supplementary Information to CE 701340

Issued To: **Abbott Medical**
5050 Nathan Lane North
Plymouth
Minnesota
55442
USA

Certificate History

Date	Reference Number	Action
12 December 2018	9663723	First Issue. Mirror certificate to CE 597706.
05 March 2019	8250541	Traceable to NB 0086.
10 April 2019	9752528	Addition of Sterigenics US, LLC, Salt Lake City, Utah for ETO Sterilization.
Current	3053900	Addition of Midwest Sterilization Corporation, Jackson, Missouri USA for ETO Sterilization in chambers 1, 2, 3, 6, and 13.

First Issued: **2018-12-12**

Date: **2019-12-16**

Expiry Date: **2023-05-15**

...making excellence a habit.™

Abbott Declaration of Conformity Swartz Braided Transseptal Guiding Introducers

Abbott Medical (Abbott) hereby declares that the following Abbott facilities and products conform to the applicable provisions of Annex II of the Medical Device Directive (MDD) 93/42/EEC as amended by 2007/47/EC. All supporting documentation is retained under the premises of Abbott. We declare no application has been lodged with any other notified body for the same products. This declaration is issued under the sole responsibility of the manufacturer. This declaration supersedes any declaration issued previously for the same product(s).

Manufacturer Address: Abbott Medical
5050 Nathan Lane
Plymouth, MN 55442 USA

European Representative: Abbott Medical
The Corporate Village
Da Vincilaan 11 Box F1
1935 Zaventem, Belgium

Product Type: Introducer

Product Name(s): Swartz Braided Transseptal Guiding Introducer

Model Number(s): See Table 1 and Table 2

Classification: Class III, Rule 7 according to Annex IX of the MDD 93/42/EEC as amended by 2007/47/EC

GMDN Code(s): 47247 – Transseptal access system

Original CE Mark Date: 23 Aug 2011

Certificate No and expiration date: Design Exam Certificate No: CE 701340
Expiration Date: 15 May 2023

Full Quality Assurance Certificate No: CE 701333
Expiration Date: 26 May 2024

Applicable Quality System Standards: EN ISO 13485:2016

Notified Body: BSI Group The Netherlands B.V.
Say Building
John M. Keynesplein 9
1066 EP Amsterdam
The Netherlands

Notified Body Number: 2797

Signature:

Blair Schwartz
Sr. Regulatory Affairs Manager

Issue Date

Abbott Declaration of Conformity Swartz Braided Transseptal Guiding Introducers

Table 1: Swartz Braided Transseptal Guiding Introducers

Reorder Number	Sheath Size (French)	Dilator Size (French)	Maximum Guidewire Dia. (in)	Curve Type	Sheath Usable Length (cm)	Dilator Usable Length (cm)
407439	8	8	0.032	SL1	63	67
407440				SL1	81	85
407441				SL2	63	67
407442				SL2	81	85
407443				SL3	63	67
407445				SLR3	63	67
407446				SL4	63	67
407448				SLR4	63	67
407449				SL0	63	67
407450				SL0	81	85
407451	8.5	8.5		SL0	63	67
407452				SL0	81	85
407453				SL1	63	67
407454				SL1	81	85
407455				SL2	63	67
407456				SL2	81	85
407457				SL3	63	67
407459				SL4	63	67

Table 2: Swartz Braided LAMP Transseptal Guiding Introducers

Reorder Number	Sheath Size (French)	Dilator Size (French)	Maximum Guidewire Dia. (in)	Curve Type	Sheath Usable Length (cm)	Dilator Usable Length (cm)
407356	8	8	0.032	LAMP 90	63	67
407357	8	8			81	85
407358	8.5	8.5			63	67
407359	8.5	8.5			81	85
407360	8	8		LAMP 45	63	67
407362	8.5	8.5			63	67
407363	8.5	8.5			81	85
407364	8	8		LAMP 135	63	67
407365	8	8			81	85
407366	8.5	8.5			63	67
407367	8.5	8.5			81	85

Signature:

 Blair Schwartz
 Sr. Regulatory Affairs Manager

 05Apr 2021
 Issue Date



25 Apr 2023

Our ref: Swartz Braided Transseptal Guiding Introducers and Fast-Cath Introducers

To: Whom it may concern

This letter confirms that BSI – Netherlands, an EU Notified Body (designation CE 2797), has issued the following Directive certificates to the Legal Manufacturer Abbott Medical (also known as St. Jude Medical prior acquisition), 5050 Nathan Lane North, Plymouth, MN 55442, USA:

EC Certificate – Full Quality Assurance System – MDD 93/42/EEC Annex II.3		
Certificate	Scope	Expiry
CE 701333	Design, Development, and Manufacture of Electrophysiology Catheters including Radio Frequency (RF) Ablation Electrodes and Catheters, Return Electrodes, Radio Frequency (RF) Ablation Generators, Introducers and Needles, Catheters, Diagnostic Guidewires, Guidewires, and Accessories. Those aspects of Annex II related to securing and maintaining the sterility in the manufacture of Sterile Cables/leads for use with Electrophysiology Catheters, Guidewire Torque Devices, Hemostasis and Compression devices. Those aspects of Annex II related to maintaining the measuring function of FemoStop Pump systems.	26 May 2024
CE 797699 (mirror cert under St. Jude Medical)	Design, Development, and Manufacture of Electrophysiology Catheters including Radio Frequency (RF) Ablation Electrodes and Catheters, Return Electrodes, Introducers and Needles, Catheters, Diagnostic Guidewires, and Accessories. Those aspects of Annex II related to securing and maintaining the sterility in the manufacture of Sterile Cables/leads for use with Electrophysiology Catheters, Hemostasis and Compression devices. Those aspects of Annex II related to maintaining the measuring function of FemoStop Pump systems.	26 May 2024

EC Design-Examination Certificate – Directive 93/42/EEC on Medical Devices, Annex II Section 4		
Certificate	Scope	Expiry
CE 701340 CE 597706 (mirror cert under St. Jude Medical)	Swartz Braided Transseptal Guiding Introducers	15 May 2023

BSI Group The Netherlands B.V.
Say Building
John M. Keynesplein 9, 1066 EP Amsterdam
PO Box 74103, 1070 BC Amsterdam
The Netherlands

T: +31 20 346 0780
BSIMedDev.NB2797@bsigroup.com
bsigroup.com
bsigroup.nl





EC Design-Examination Certificate – Directive 93/42/EEC on Medical Devices, Annex II Section 4		
Certificate	Scope	Expiry
CE 701338 CE 597705 (mirror cert under St. Jude Medical)	Fast-Cath Introducers	15 May 2023

BSI confirms that the Legal Manufacturer has applied for MDR certification with BSI including signing an application contract by 26 May 2024 and before the expiration of the Directive certificates.

BSI has issued EU Quality Management System Certificate MDR 728953 under Medical Device Regulation (EU) 2017/745, Annex IX Chapter I and III to the Legal Manufacturer:

Abbott Medical
5050 Nathan Lane North
Plymouth
Minnesota
55442
USA

The following devices are covered under MDR 728953 within the device schedule:

EU Quality Management System Certificate, MDR 2017/745 Annex IX Chapter I and III	
Class III device	Intended Purpose
Swartz Braided Transseptal Guiding Introducers	See MDR 759191
Fast-Cath Introducers	See MDR 759190

In addition to the EU Quality Management System MDR 728953, BSI also issued EU Technical Documentation Assessment Certificates for Class III devices. BSI has issued EU Technical Documentation Assessment Certificate MDR 759191 and MDR 759190 under Regulation (EU) 2017/745 Annex IX Chapter II, to the aforementioned Legal Manufacturer in respect of the above devices. Both certificates were first issued on 14 Feb 2023 and valid until 13 Feb 2028.

Should you have any questions regarding this letter or the certificates issued by BSI, please do not hesitate to contact me.

Yours sincerely,
Chase Thompson

Chase.Thompson@bsigroup.com
Technical Team Manager – Vascular
Medical Devices
BSI Group

Certificate of Registration

QUALITY MANAGEMENT SYSTEM - ISO 13485:2016

This is to certify that:

Abbott Medical Costa Rica Ltda.
Edificio #44
Calle 0, Ave. 2
Zona Franca Coyol
El Coyol, Alajuela
Costa Rica

Holds Certificate No:

FM 728657

and operates a Quality Management System which complies with the requirements of ISO 13485:2016 for the following scope:

Manufacture and distribution of radio-frequency (RF) ablation catheters, electrophysiology (EP) catheters, intracardiac echocardiography catheters, cardiac mapping system accessories, transeptal access system, introducer catheters, vascular closure systems; and the design of cardiac mapping system accessories.

For and on behalf of BSI:

Graeme Tunbridge, Senior Vice President Medical Devices

Original Registration Date: 2020-05-06

Effective Date: 2021-12-14

Latest Revision Date: 2022-03-22

Expiry Date: 2024-12-13



Page: 1 of 1

...making excellence a habit.™

CERTIFICATE



This is to certify that



SANTE
INTERNATIONAL S.A.

SANTE INTERNATIONAL S.A.

Str. Mantuleasa nr. 33, Sector 2
023961 Bucuresti
Romania

has implemented and maintains a **Quality Management System**.

Scope:

Import, trade and storage of medical and laboratory equipment, disinfectants, laboratory reagents, cardiovascular surgery devices, service for medical and laboratory equipment. Consulting for state and private medical units.

Through an audit, documented in a report, it was verified that the management system fulfills the requirements of the following standard:

ISO 9001 : 2015

Certificate registration no.	497269 QM15
Valid from	2021-06-16
Valid until	2024-06-15
Date of certification	2021-06-16



DQS GmbH

Markus Bleher
Managing Director

Accredited Body: DQS GmbH, August-Schanz-Straße 21, 60433 Frankfurt am Main, Germany
Administrative Office: DQS Romania, Str. Bătuului nr. 11, 020565 Bucharest - Romania



**Annex to certificate
Registration No. 497269 QM15**

SANTE INTERNATIONAL S.A.

Str. Mantuleasa nr. 33, Sector 2
023961 Bucuresti
Romania

Location

Scope

**075906
Sante International SA
Sos. Mihai Bravu nr. 7, bl. P37-P37A,
sector 2
021303 Bucuresti
Romania**

Import, trade and storage of medical and laboratory equipment, disinfectants, laboratory reagents, cardiovascular surgery devices. Consulting for state and private medical units.

**497270
Sante International SA
Str. Pupitrului, nr. 81,
sect. 3
033036 Bucuresti
Romania**

Storage of medical and laboratory equipment, disinfectants, laboratory reagents, cardiovascular surgery devices, service for medical and laboratory equipment. Consulting for state and private medical units.

**31050285
Sante International SA
Calea Ghirodei, nr. 36
300327 Timisoara
Romania**

Trade of medical and laboratory equipment, disinfectants, laboratory reagents, cardiovascular surgery devices, service for medical and laboratory equipment. Consulting for state and private medical units.

**31050284
Sante International SA
Calea Dorobantilor, nr. 111
400609 Cluj-Napoca
Romania**

Trade of medical and laboratory equipment, disinfectants, laboratory reagents, cardiovascular surgery devices, service for medical and laboratory equipment. Consulting for state and private medical units.

**31050283
Sante International SA
Str. Lascar Catargi, nr. 37
700107 Iasi
Romania**

Trade of medical and laboratory equipment, disinfectants, laboratory reagents, cardiovascular surgery devices, service for medical and laboratory equipment. Consulting for state and private medical units.