

Contrast Delivery System

DUAL SHOT alpha7 Operation Manual

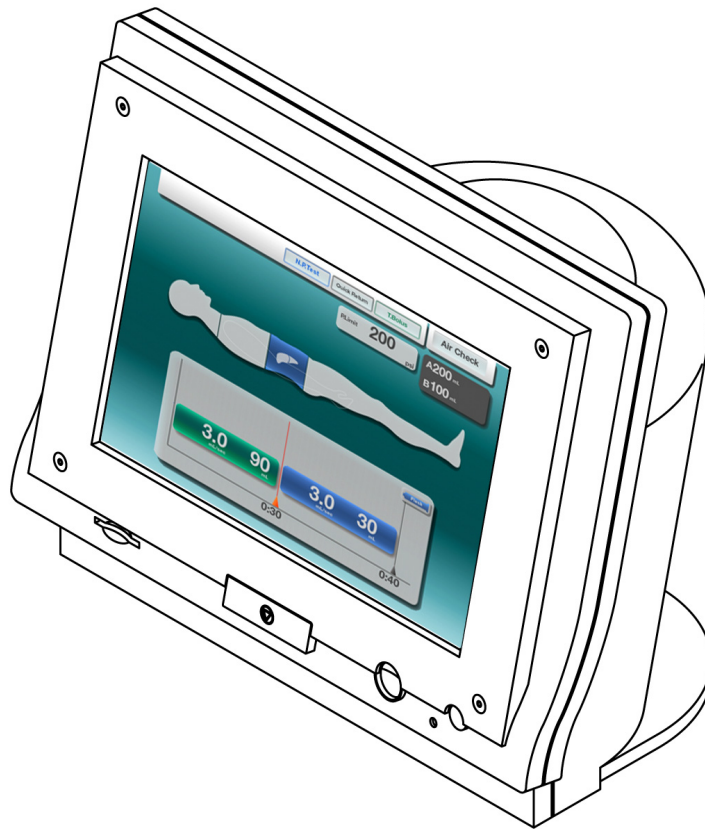

This injector is the contrast medium injector system working with CT scanner.

RoHS Compliant

THE POINT OF THE Contrast Delivery System DUAL SHOT alpha7

- The Contrast Delivery System DUAL SHOT alpha7 CT injector is intended for use by a medical practitioner to inject the contrast media into humans for the purpose of performing CT examination procedure.
- The Contrast Delivery System DUAL SHOT alpha7 CT injector is designed user friendly to allow the user to be able to operate without any specific training.
- Injection Protocols could be selected from the accustomed examination area.
- Flow Rate and the Volume could be set to any value.
- Numeric value could be set by two methods, up/down keys and the accustomed 10 key pad.
- The Console is easily seen with the large 10.4inch SVGA LCD.
- Setting could be set by the Touch Panel intuitively.
- The caster wheels are provided to be able to put aside when it is not to use.

1. Introduction	1
2. Markings	2
2.1. Instruction Markings.....	2
3. Read Before Use	5
4. Precautions during Use	6
5. Consumables	9
6. Specifications	10
6.1. Electric Rating.....	10
6.2. Safety Device.....	10
6.2.1. Warning and Alarm Messages.....	10
6.2.2. Ceiling Mount (optional).....	10
6.2.3. Fuse.....	10
6.3. Environmental Conditions.....	10
6.4. Programming Range.....	11
6.4.1. Volume Programming Range.....	11
6.4.2. Flow Rate Programming Range.....	11
6.4.3. Pressure Limit Programming Range.....	11
6.4.4. Pause Time.....	11
6.4.5. Inject Delay Time.....	11
6.4.6. Ramp-Up Time.....	11
6.4.7. Dimensions.....	12
6.4.8. Weights.....	12
7. System Overview	13
7.1. System Components.....	13
7.2. Other Components.....	14
7.3. Structure and Principal of Operation.....	16
7.3.1. Basic Connection Diagram.....	16
7.3.2. Principle of Operation.....	17

8. Names of Individual Parts	19
8.1. Powerhead	19
8.2. Powerhead LED Displays	20
8.3. Switch Box	21
8.4. Console.....	22
9. Basic Procedures.....	24
9.1. How to Turn On the Injector	24
9.2. How to Turn Off the Injector	25
9.3. Basic Operations	26
9.3.1. Starting injection from control room.....	28
9.3.2. Starting injection from examination room	28
9.3.3. Stopping injection from examination room.....	29
9.3.4. Stopping injection from Control Console.....	29
9.3.5. Stopping injection from Switch Box	29
9.3.6. Stopping Injection from Touchscreen	30
9.3.7. Air Check Cancel	30
9.4. Console Operation.....	31
9.4.1. Basic Operation	31
9.4.2. 10-Key Keypad Operation.....	31
9.4.3. HOME Screen	32
9.5. Insertion and Removal of a Syringe and Adapter	33
9.5.1. Insertion of Syringe Adapters.....	33
9.5.2. Removal of Syringe Adapter	33
9.5.3. Insertion of Syringe into Adapter	34
9.5.4. Removal of Syringe from Adapter	34
9.6. Syringe Filling.....	35
9.7. Connection of the injection line	36
10. Operation Procedure.....	37
11. Flow Rate Mode.....	42
11.1. Screen Explanation.....	42
11.2. Protocol Setup	45
11.2.1. Flow Rate Screen Selection.....	45
11.2.2. Pressure Limit Setup.....	45
11.2.3. Injection Flow Rate and Volume Setting	46

11.2.4. Flush Setup.....	46
11.2.5. Volume Reset.....	47
12. Protocol Memory	48
12.1. Accessing Protocol Memory Menu	48
12.2. New Protocol	50
12.3. Edit / Delete Protocol.....	53
12.3.1. Modifying the Protocol Name.....	54
12.3.2. Modifying the Protocol Pattern.....	56
12.3.3. Modifying the protocol details.....	59
12.3.4. Delete Protocol.....	61
12.4. Alphabetic Keyboard Overview	63
13. Needle Placement Test.....	64
14. T.Bolus	65
15. Quick Return.....	66
16. Injection Results Screen	67
17. Warning and Information Screens.....	68
17.1. Blocked Line Warning.....	68
17.1.1. Resuming the injection.....	70
17.2. Switch Alarm at power up	70
17.3. Warning Screen.....	70
17.4. Alarm Screen	71
17.5. Syringe Adapter Warnings.....	71
17.6. Pressure Limit Warnings	72
18. Injector Setup.....	73
18.1. Date / Time Set	74
18.2. Sound Level.....	74

18.3. Flow Rate Warning	74
18.4. T.Bolus / N.P.Test	75
18.5. Results Display Time	75
18.6. Quick Return Speed	75
18.7. Quick Purge Volume Set	76
18.8. Language Select	76
18.9. Calibration	77
18.9.1. When the calibration is not completed properly	79
18.10. RTC Check Function (Date/Time Set Check Function)	79
19. Daily and Periodic Inspections	80
19.1. Daily Inspection	80
19.2. System Inspection	80
19.3. Powerhead and Remote Stand Inspection	80
19.4. Ceiling Suspension Inspection (optional)	80
19.5. Cleaning	81
19.6. Operation Check	81
20. Planned Maintenance	82
21. Troubleshooting	83
22. Guidance and manufacturers declaration	86
23. Contact Information	91



1. Introduction

Thank you for purchasing our Contrast Delivery System DUAL SHOT alpha7.

- To ensure safe, reliable and proper use of the device please read this Operators Manual thoroughly.
- Keep this Operators Manual in a convenient location for easy reference.
- Observe all Danger, Warning and Cautions provided in this Operators Manual to prevent hazardous situation for users or patients and to reduce the likelihood of any damage to the device.









2. Markings















Markings used in this Operator Manual and their descriptions are as follows.











 Danger	This symbol indicates hazards which will directly lead to serious personal injury, death or malfunction of the device.
 Warning	This symbol indicates hazards which will indirectly lead to serious personal injury, death or malfunction of the device.
 Caution	This symbol indicates hazards which could lead to personal injury, device malfunction or property damage.

2.1. Instruction Markings

The following symbols are used on the Contrast Delivery System DUAL SHOT alpha7.

Symbol	Description
	Caution, pinch point
	Caution!
	Keep away from sunlight
	Keep dry
	Handle with care
	Keep upright
	Temperature limitation
	Date of manufacture

Symbol	Description
	"ON" (power)
	"OFF" (power)
	"ON/OFF" (push-push)
	Protective Earth
	Alternating current
	Direct current
	Hazardous voltage
	Start of injection
	Stop of injection
	Type CF applied part
	Forward advance at slow speed
	Forward advance at medium speed
	Forward advance at fast speed
	Backward retraction at slow speed

Symbol	Description
	Backward retraction at medium speed
	Backward retraction at fast speed
	Licensed by TÜV Rheinland, indicates the product complies with UL and CSA standard in US and Canada. TÜV Rheinland is a Nationally Recognized Testing Laboratory (NRTL) by the Occupational Safety and Health Administration (OSHA).
	Indicates conformance to European 93/42/EEC Medical Device Directive
	Indicates conformance to 2011/65/EU RoHS Directive.
	Indicates that wastes of electric and electronic equipment must be disposed of in accordance with your local laws and regulations. Please contact an authorized representative of the manufacturer regarding the proper disposal of your equipment.
	Symbol for "CONSULT OPERATION MANUAL"
	Serial Number
	It shows this system is the medical equipment working with CT scanner.
	This shows prohibition to bring this system into the room where MRI system is installed.
	Used to access the HOME screen.

3. Read Before Use

- **INTENDED USE:** The DUAL SHOT alpha7 is intended for use by a medical practitioner to inject contrast medium and physiological saline into humans for the purpose of performing radiography procedures. This device is not approved for any other purpose than its INTENDED USE.
- Do not use the device in connection with equipment that has not been approved or specified by Nemoto. Nemoto shall not be liable for any malfunction as a result of using the device outside its INTENDED USE or as a result of, but not limited to, the following:
 - Any malfunction or damage of this system resulting from not adhering to the Precautions for Use and operating instructions specified in this Operation Manual.
 - Any malfunction or damage of this system resulting from the deviation of operating environment specified in the Operation Manual, such as power sources, installation conditions, etc.
 - Any malfunction or damage of this system resulting from any natural disasters, such as fire, earthquake, flood, lightning, etc.
 - Any malfunction or damage of this system resulting from use with products not approved or specified by Nemoto.
- Modifications may be made to this Operation Manual without notice.
- Please contact us if you need clarification or further information regarding the DUAL SHOT alpha7. Contact information can be found at the end of this Operation Manual.
- The DUAL SHOT alpha7 complies with IEC60601-1-2:2007. This system uses electro-magnetic energy for its internal function only and does not transmit electro-magnetic energy to the patient. However, note that even small amounts of leakage of electro-magnetic energy may damage nearby sensitive equipment.
- This system needs special precautions regarding EMC and needs to be installed and put into service according to the EMC information provided in the accompanying documents.
- Portable and mobile RF communications equipment can affect this system.
- The spare part with this system other than those specified may result in increased emissions or decreased immunity of this system.
- This system should not be used adjacent to or stacked with other equipment and that if adjacent or stacked use is necessary, this system should be observed to verify normal operation in the configuration in which it will be used.
- This system is not intended to be sterilized or disinfected. Do not apply any sterilization or disinfect process.

4. Precautions during Use

- To ensure safe, reliable and proper use of the device please read this Operators Manual thoroughly.
- Keep this Operators Manual in a convenient location for easy reference.
- Aside by all Danger, Warning and Cautions in the labeling of this product.
- Follow all instructions for use, cautions, warnings, etc. when using contrast media that are provided by the respective contrast media manufacturers.

Danger

- Do not bring this system into MR room. It is extremely dangerous because this system shall be suddenly and strongly pulled to MRI equipment due to strong magnetic field.
- To insure correct and safe operation of the DUAL SHOT alpha7, the installation shall be performed by someone trained and qualified for Medical Device installation. If reinstallation is required please contact Nemoto or your authorized representative.
- This device must not be used by anyone other than qualified and trained persons.
- To ensure safe and reliable operation this device must be installed and set up in accordance with all installation instructions provided in our Installation Manual.
- This device must only be used in conjunction with equipment specifically approved by the manufacturer. Use with any unapproved equipment may lead to misdiagnosis, user or patient hazards or equipment damage.
- This device must only be used with the approved list of consumables (Reference Section 5). Use with any unapproved consumables may lead to misdiagnosis, user or patient hazards or equipment damage.
- To avoid the risk of possible electrical shock, observe caution when connecting and disconnecting power, e.g. using wet hands, pulling on cable, etc. Only permit device housings to be removed and service to be performed by trained and qualified personnel.
- There is a risk of possible fire or electrical shock if usage is continued under any abnormal conditions. In the event of smoke or unusual smell(s) please discontinue use immediately and contact the manufacturer or authorized representative.
- Please use only the Nemoto approved consumables (syringes, tubing, and needles) and make certain to follow all instructions for use and cautions listed in the instruction manual and consumables package.

 **Warning**

- Before initiating any injection protocol, always check to make certain the proper protocol parameters have been programmed into the injector.
- Before injections make certain syringe, tubing, stop-cocks, valves, etc. are open or correctly positioned for injection. In the event a blocked-line injection occurs take precautions to make certain the pressure is relieved before clearing line. Disconnect line from patient if necessary to relieve pressure.
- This device is not equipped with functions that will automatically detect or remove air. Before injection observe good clinical practice and remove all air from syringe and tubing.
- Disconnect tubing from patient before removing the syringe(s).
- Before using the Auto-Return function, disconnect tubing from patient and remove syringes. Failure to take these precautions may lead to air injection or possible contamination from reusing an empty syringe.
- To avoid the risk of electrical shock, this equipment must only be connected to a supply main with protective earth.
- Modification to this device by non-qualified persons, or without authorization and instructions from the manufacturer are strictly prohibited and could result in personal injury, patient injury and damage to the device.

 **Caution**

- In the event of device failure, only permit repair by trained and qualified personnel. Contact the manufacturer or authorized representative for assistance.
- To ensure safe and reliable operation of the device do not change or alter its design, assembly, and installation or operate other than as specified by the accompanying document.
- In the event liquid ingresses into the device, discontinue use and remove power to avoid risk of fire or electrical shock. Contact an authorized representative for service and repair.
- When the syringe is filling or pulling in the reverse direction, do not remove or disconnect the syringe from the Powerhead ram. This may result in a sudden pressure relief causing the syringe to break, or move forward at a rapid rate.
- Be sure to confirm the pressure limit setting with all consumables (syringe, tubing, etc.) being used at the time of injection. Improper setting of the pressure limit may lead to leakage or bursting of consumable product.
- The real time pressure curve is provided to show the profile of the injection in process. It should not be used, as it has not been approved, as a means of detecting extravasations.
- Be sure the syringe, and adapter if applicable, is properly installed before starting an injection protocol. Incorrect installation may lead to interrupted procedure, leakage of syringe, damage to syringe or injector, etc.
- To correctly stop an injection use a stop button located on the Powerhead or Remote Switch Box. Do not use a stop-cock to stop an injection in process.
- Use caution when installing and removing syringes as this is a pinch-point area.
- Leakage from tubing may occur after purging due to siphoning effects. Keep tubing blocked or higher than syringe tip to prevent leakage.
- Exposure to shocks, dropping, falling over, etc. outside that seen in normal use, may lead to internal damage. Contact the manufacturer or authorized representative for device inspection.
- Do not forcefully bend, twist, pull, apply heat or place heavy objects on the power cable as this may lead to damage of the cable. To avoid risk of fire or electrical shock, replace damaged cables immediately.
- Maintenance
 - Follow all manufacturer recommended inspections and preventative maintenance specified in this manual.
 - If the device has not been used for an extended period of time it is recommended a qualified person inspect the device for proper operation before use.
- Disposal of Device
 - Dispose of this device in accordance with all local, state and federal laws and regulations. Please contact the manufacturer or its authorized representatives regarding the proper disposal.

5. Consumables

- Do not use this system for any other purpose outside of its stated INTENDED USE.
- High pressures are generated during the injection procedure. Be certain to only use those consumables (syringes, tubing, etc.) that have been approved by Nemoto.

APPROVED CONSUMABLES

There may be a risk of leakage, breakage, etc. if consumables other than those approved by Nemoto are used.

Nemoto Approved Consumables

Nemoto Part #	Product Description
C855-5408	Dual 200mL Syringe/Y-set w1CV/Spike
C855-5308	Dual Syringe/Y-set w1CV/Spike
C855-5304	Dual Syringe/Y-set w1CV/J-Tube
C855-5206	Single Syringe/ 60" Coiled Line/Spike
C855-5202	Single Syringe/ 60" Coiled Line/J-Tube
C855-5201	200mL Syringe w/J-Tube
C855-5101	100mL Syringe w/J-Tube
SYPET-200	200mL Syringe Only
SYPET-100	100mL Syringe Only

6. Specifications

6.1. Electric Rating

	Powerhead	Console
Rated voltage	AC100 - 240V 50/60Hz	
Power output or consumption	160VA Max	
Type of protection	Class I	
Level of protection	Type CF	
Drip-proof construction	Yes	-
Classification by operation mode	Continuous operation	
AP - APG support	Not supported	

6.2. Safety Device

6.2.1. Warning and Alarm Messages

The device is equipped with several warning and alarm message indications. Warning messages, when present require user intervention before operation can continue. An alarm message requires power to be cycled. If the alarm message persists, contact your authorized service representative. Refer to the Troubleshooting section of this manual for additional information.

6.2.2. Ceiling Mount (optional)

The ceiling mount arm that attaches to the ceiling suspension system and supports the DUAL SHOT alpha7 Powerhead is equipped with an internal safety mechanism. The safety mechanism installation is described in the DUAL SHOT alpha7 Installation Manual. In the event of failure the safety mechanism will catch and support the Powerhead. If a failure occurs discontinue use of the ceiling suspension and contact the manufacturer or authorized representative for repair.

6.2.3. Fuse

Control Console

T5A250Vx2

6.3. Environmental Conditions

Transportation and storage

Temperature: -40°C - 70 °C

Humidity: 5% - 95%

Atmospheric pressure: 500hPa - 1060hPa

Operating

Temperature: 5°C - 40 °C

Humidity: 10% - 90% (Non-Condensing)

Atmospheric pressure: 680hPa - 1060hPa

6.4. Programming Range

6.4.1. Volume Programming Range

A side

200mL syringe 1 - 200mL (1mL increments)

100mL syringe 1 - 100mL (1mL increments)

B side

200mL syringe 1 - 200mL (1mL increments)

100mL syringe 1 - 100mL (1mL increments)

6.4.2. Flow Rate Programming Range

A side

200mL syringe 0.1 - 10mL/sec (0.1mL/sec increments)

100mL syringe 0.1 - 10mL/sec (0.1mL/sec increments)

B side

200mL syringe 0.1 - 10mL/sec (0.1mL/sec increments)

100mL syringe 0.1 - 10mL/sec (0.1mL/sec increments)

6.4.3. Pressure Limit Programming Range

200mL syringe 10 to 300 PSI (10 psi increments)
100 to 2058 kPa (100kPa increments)
1.0 to 21.0kg/cm² (0.1kg/cm² increments)

100mL syringe 10 to 300 PSI (10 psi increments)
100 to 2058 kPa (100kPa increments)
1.0 to 21.0kg/cm² (0.1kg/cm² increments)

6.4.4. Pause Time

Range 0 to 300 seconds (1 second increments)

6.4.5. Inject Delay Time

Range 0 to 300 seconds (1 second increments)

6.4.6. Ramp-Up Time

0 or 2 seconds

6.4.7. Dimensions

Powerhead	23.62 x 4.41 x 7.09 in.	600 x 112 x 180 mm
Control Console	4.21 x 10.63 x 9.76 in.	107 x 270 x 248 mm
Remote Stand	23.62 x 23.62 x 47.24 in.	600 x 600 x 1200 mm

6.4.8. Weights

Powerhead	18.75 lb.	8.5 kg
Control Console	8.16 lb.	3.7 kg
Remote Stand	25.35 lb.	11.5 kg

7. System Overview

7.1. System Components

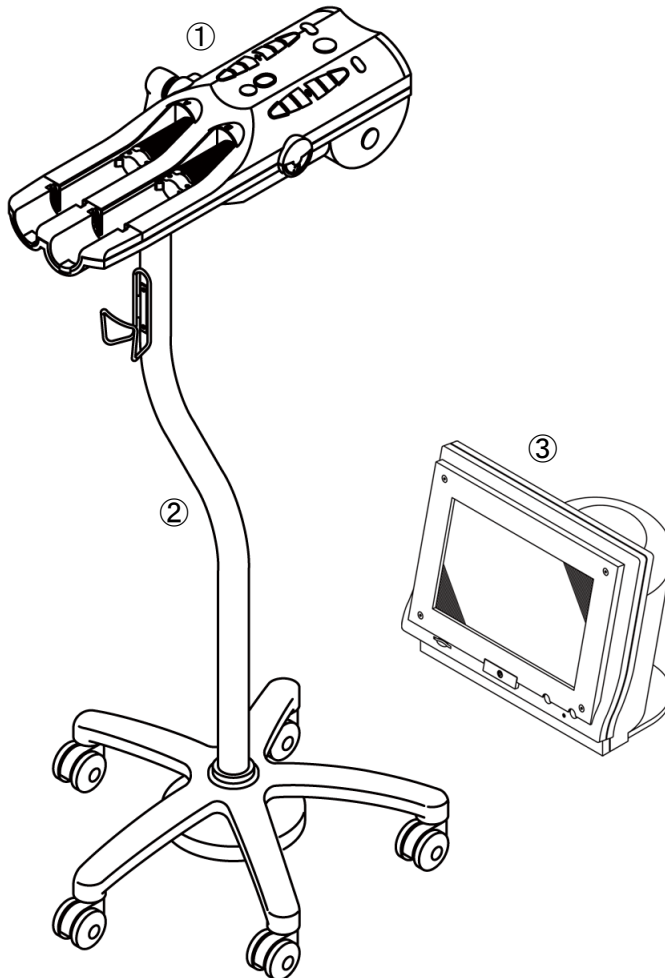

①	Powerhead
②	Remote Stand Optional at the time of shipment. Note : This is not included with the ceiling mount type.
③	Console

7.2. Other Components

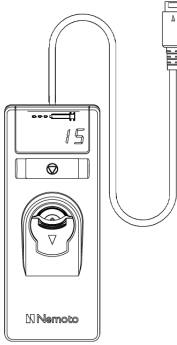

Switch Box

Used to start an injection from the Control Console

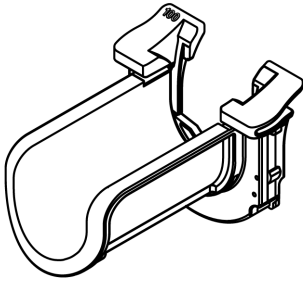

Syringe Adapter, 100mL

Used with the 100mL syringe

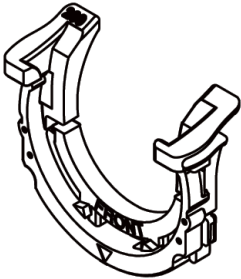

Syringe Adapter, 200mL

Used with the 200mL syringe

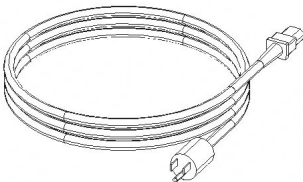

Power Cable

Used to connect the AC Power to the injector.

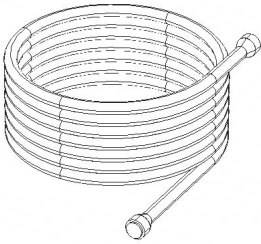
**Powerhead Extension Cable**

Used for extending the length of the Powerhead cable.

**Ceiling Mount Powerhead Arm (optional at time of shipment)**

Used to mount the Powerhead to the ceiling suspension column.

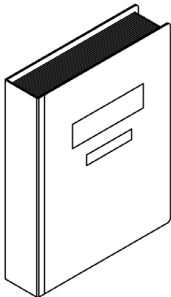
**Operation Manual (this book)**

Describes how to properly operate the DUAL SHOT alpha7 contrast delivery system.

ATTENTION: Be sure to read this manual thoroughly, plus any other related documentation to ensure safe and reliable operation.

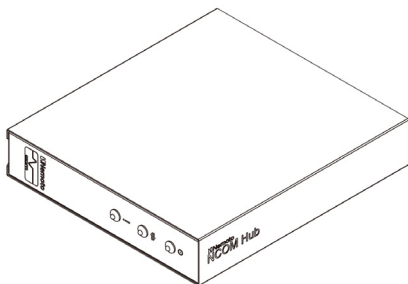
**NCOM Hub (Option)**

For further details refer to the NCOM Operation Manual.

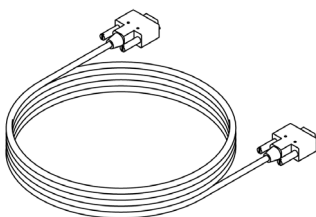
**NCOM Hub Cable (Option)**

For further details refer to the NCOM Operation Manual.

7.3. Structure and Principal of Operation

! Warning

To assure proper installation and operation of the unit, follow the installation and checkout procedures in the DUAL SHOT alpha7 Installation Manual. The following is provided for general information only and should not be used as complete installation and checkout instructions.

7.3.1. Basic Connection Diagram

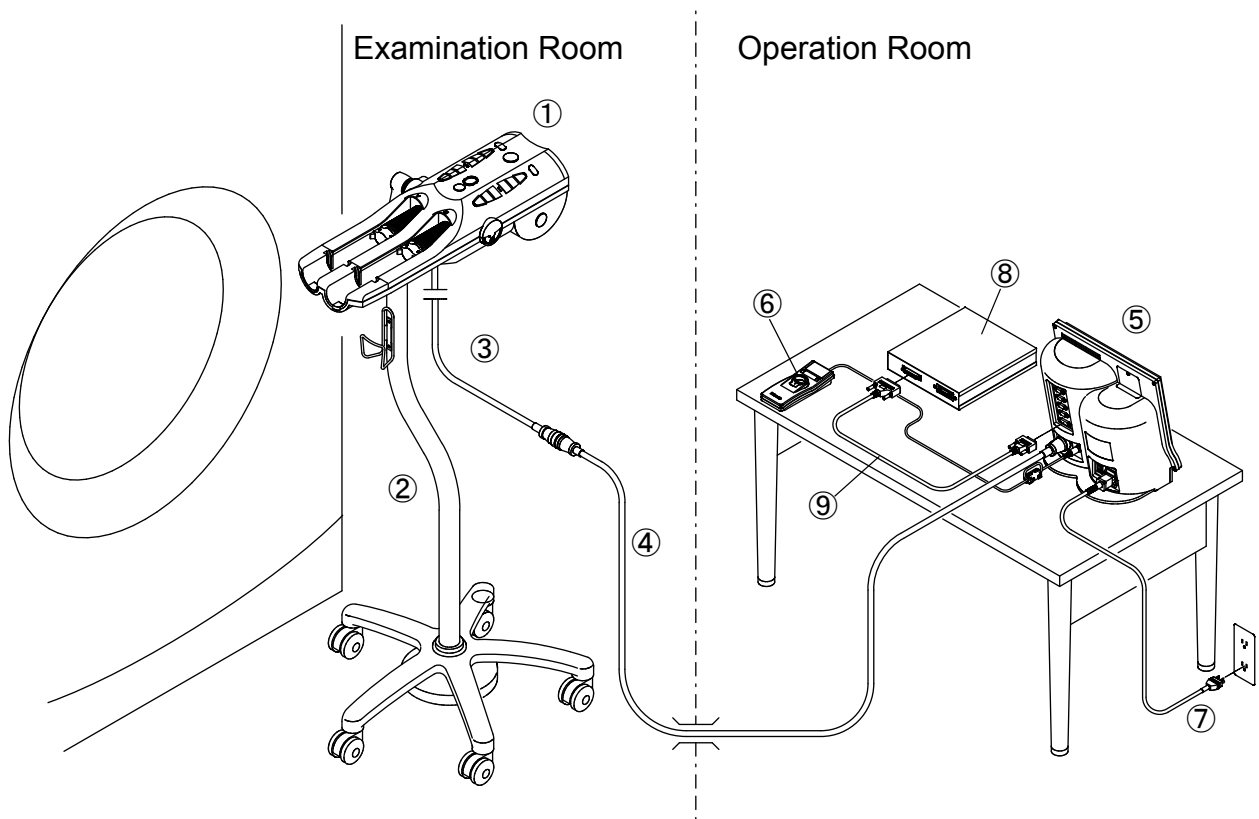

①	Powerhead	⑥	Switch Box
②	Remote Stand	⑦	Power cable
③	Powerhead cable	⑧	NCOM Hub (Option)
④	Powerhead extension cable	⑨	NCOM Hub Cable (Option)
⑤	Console		

7.3.2. Principle of Operation

The device accepts user inputs that will set the desired speed, movement and force that shall be used during operation. Upon initiation, the inputs shall be translated into electrical signals that cause the internal motor to rotate, turning the drive screw causing a linear motion. The linear motion will push the pressers A and B to expel the contrast and saline loaded into syringe A and B into the patient via the connected consumables.

7

System Overview

8. Names of Individual Parts

8.1. Powerhead

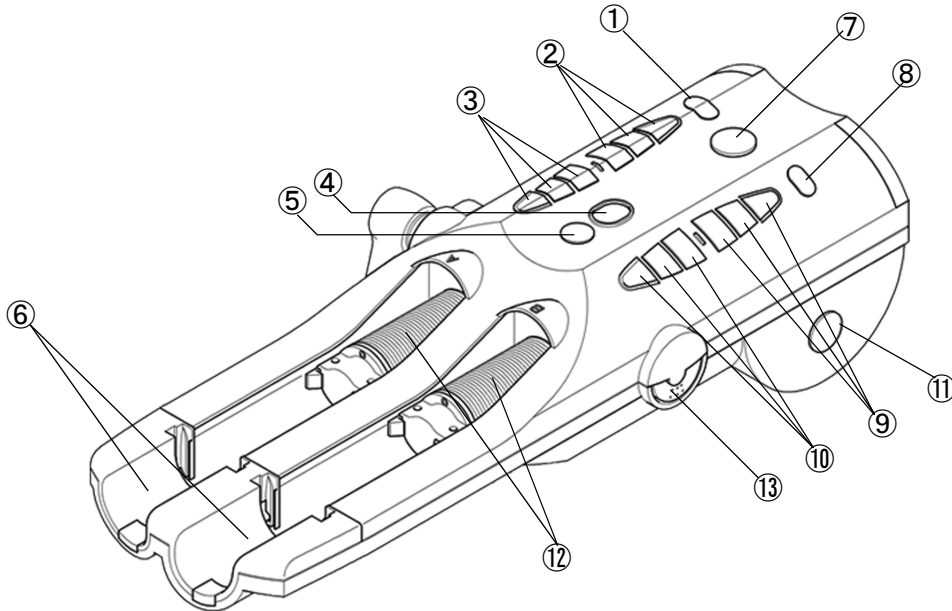

- ① A-Side Auto Return Button
Press and hold for 2 or more seconds to automatically retract the A-side ram.
- ② A-Side Reverse Buttons
Retract the A-side ram.
 ▶▶ Fast ▶ Medium ▷ Slow
- ③ A-Side Forward Buttons
Advances the A-side ram.
 ◀◀ Fast ◀ Medium ◁ Slow
- ④ Start Button
Pressing this button while "Start OK" is displayed will start the injection.
- ⑤ Check Button
Press this button after confirming no air is contained in the syringe and connection tubing. The injection cannot be started unless no air has been confirmed with Check Button.
- ⑥ Syringe Holder
Recessed areas for securing syringes or adapter. Also location of integrated heating elements.
This item is an Applied Part as defined by IEC60601-1.
- ⑦ Stop Button
Pressing this button will stop ram motion.
- ⑧ B-Side Auto Return Button
Press and hold for 2 or more seconds to automatically retract the B-side ram.
- ⑨ B-Side Reverse Buttons
Reverse the B-side ram.
 ▶▶ Fast ▶ Medium ▷ Slow
- ⑩ B-Side Forward Buttons
Advances the B-side ram.
 ◀◀ Fast ◀ Medium ◁ Slow
- ⑪ Stop Button
Pressing this button stops ram motion.
- ⑫ Powerhead ram
Pushes or pulls the syringe plunger forward or reverse.
- ⑬ Quick Purge Button (US Version)
Pressing this button will start Quick Purge function.

8.2. Powerhead LED Displays

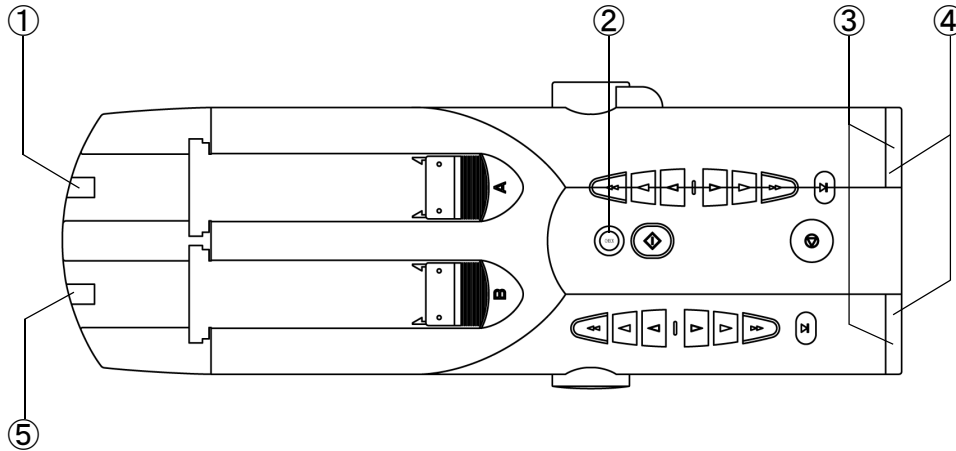

- ① **A-side Front LED**
Indicates status of A-side operation. If A-side is selected for injection, the LED illuminates. While the A-side is injecting, the LED is blinking.
- ② **Air Check LED**
It indicates the status of air check. It also functions as an air check confirmation button. It illuminates when the air check button is pressed after user performs air check. It blinks when air check is cancelled.
- ③ **Rear LED (Green)**
There are several indications available from the Rear LEDs. When both are on the status is "Start OK" meaning the injector is ready to inject. When both LEDs are flashing, an injection is in process.
When the LEDs are off, the injector is in an non-injecting state or an idle state.
- ④ **Online LED (Blue)**
It indicates the status of CT interlocking. It illuminates when the DUAL SHOT alpha7 and the CT equipment are in interlocked operation. (Optional interface must be installed)
- ⑤ **B-Side Front LED**
It indicates the status of the B-side operation. If B-side is selected for injection, the LED lights up. While the B-side is injecting, the LED is blinking.

Note: During the system power-ON sequence, all LEDs will illuminate briefly. If an alarm occurs, all LEDs will flash to indicate an alarm condition.

8.3. Switch Box

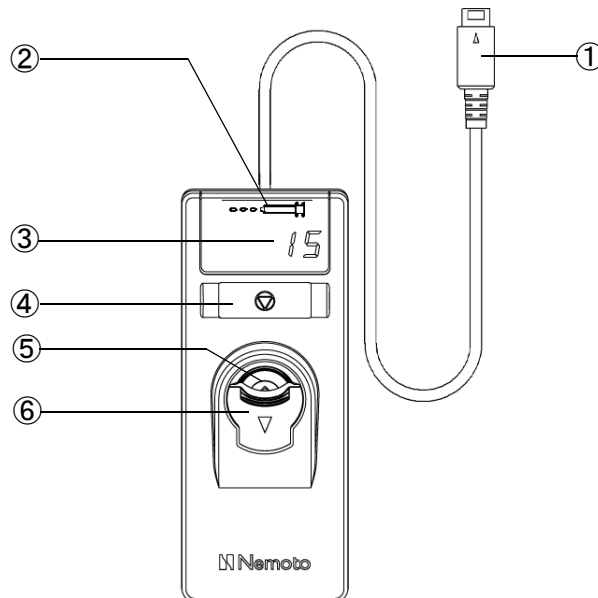

- ① Switch Box Connector
Connects the Switch Box to the Console.
- ② Operation Lamp
During an injection a syringe icon lights up.
- ③ Injecting Time Display
Starts counting up simultaneously with the start of an injection.
- ④ Stop Button
Stops an injection in progress.
NOTE: Pressing and holding for two seconds resets the injecting time to zero.
- ⑤ Start Button
Starts an injection.
- ⑥ Slide Cover
A protective cover to prevent against inadvertent activation of start switch.

8.4. Console

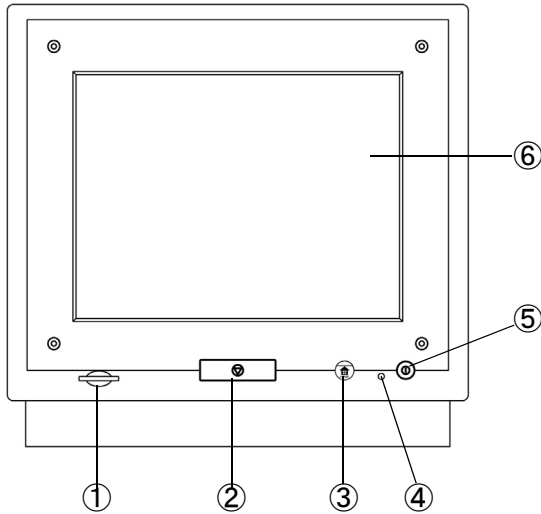

- ① SD Card Slot for update
Caution: Do not use.
- ② Stop Button
Stops an injection in progress.
- ③ HOME Button
Used to access the Home screen.
- ④ Adjustment Button
- ⑤ Power Button
Used to turn power on and off to the system.
NOTE: The Power Supply Unit must be turned on for this button to operate as indicated.
- ⑥ Touch Panel
Used to select and program injection parameters.

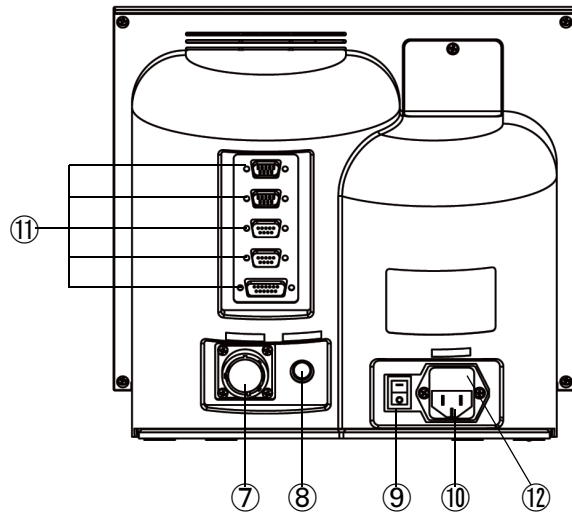

- NOTE: Touching the touch panel during an injection will put the injection in HOLD.
- ⑦ Powerhead Cable Connector
Location for Powerhead cable connection.
 - ⑧ Connector for the Switch Box
Connects to the Switch Box connector.
 - ⑨ Power Switch
Main power ON and OFF switch.
 - ⑩ Power Cable Connector
Location for power cable connection.
 - ⑪ Connector for RS-232
Connector to connect the external device.
 - ⑫ Fuse

Note:

The interface connections are designed and tested to be used with only Nemoto approved external equipment. Contact Nemoto or an authorized representative for approved external equipment and to procure the Nemoto approved interface cable for connection.

! Danger

This device must only be used in conjunction with equipment specifically approved by the manufacturer. Use with any unapproved equipment may lead to misdiagnosis, user or patient hazards or equipment damage.

! Caution

Main power fuse should only be changed by trained and qualified personnel. Use only the fuse designated by Nemoto.

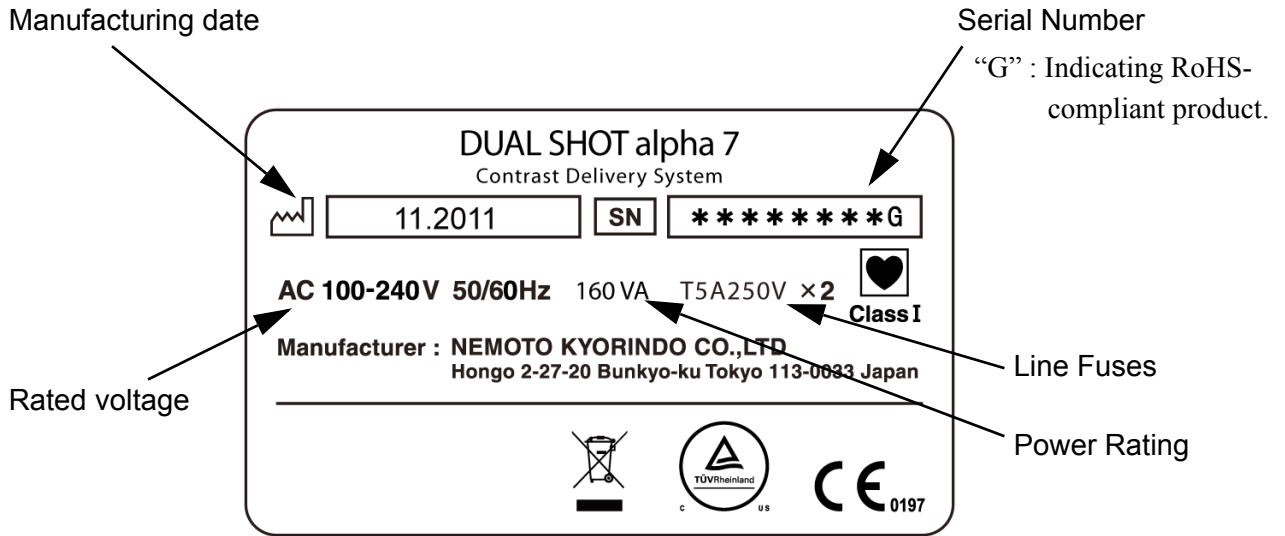

Example of Rating Label

9. Basic Procedures

9.1. How to Turn On the Injector

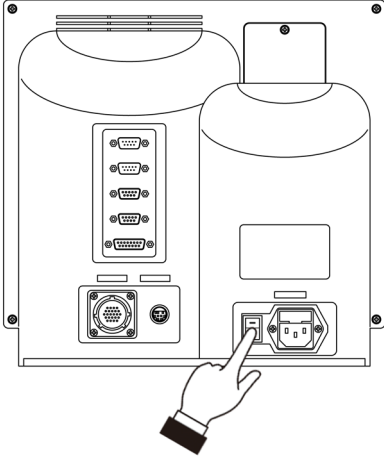

- 1) Turn on the main power.
Press the main power switch on the back side of the console to turn ON (" | " side).

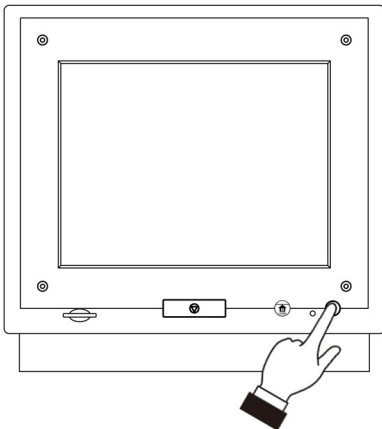

- 2) Turn on the console.
Press the power button on the front side of the console to turn on.

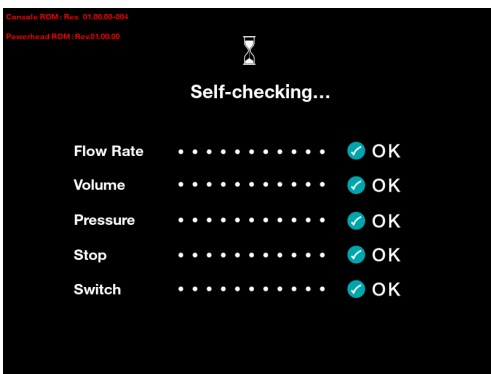

- 3) "Self-checking...."
The above message will appear on the display.
- 4) Initial Screen
The initial screen will be displayed in a few seconds. The alarm "Switch Confirmation" may be displayed. At that time, press any key on the Powerhead to continue.

Do not insert or remove the power cable or Powerhead cable when the power is ON.
Power is not applied if the main power of the Power Supply Unit is OFF.

9.2. How to Turn Off the Injector

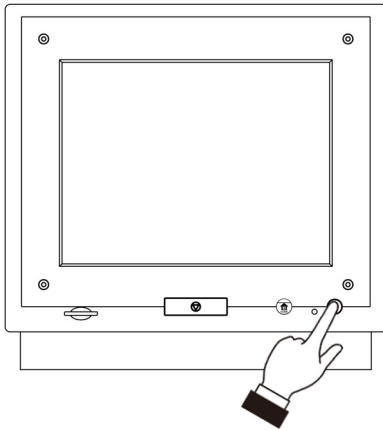

1) Turning OFF the power

Press the button identified on the Control Console. The LED of the power supply button will turn off.

Note: To preserve the backlight of the LCD, it is recommended that the Console be turned OFF when not in use.

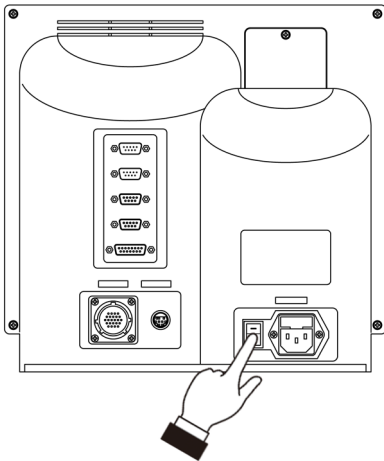

- ### 2) It is recommended to turn off the main power when not in use for an extended period. Press the power supply button on the Control Console. Then, turn off the main power switch on the rear side of the power supply unit by pressing the "O" side of the switch.

ATTENTION SERVICE PERSONNEL CHANGING THE MAIN POWER FUSE

1. Turn off power and disconnect power cord.
2. Remove cover above inlet connector to remove fuses.
3. Replace fuses only with same fuse type and rating as specified by manufacturer.
4. Insert fuses and reinstall protective fuse cover.
5. Connect power cord and apply power.

9.3. Basic Operations

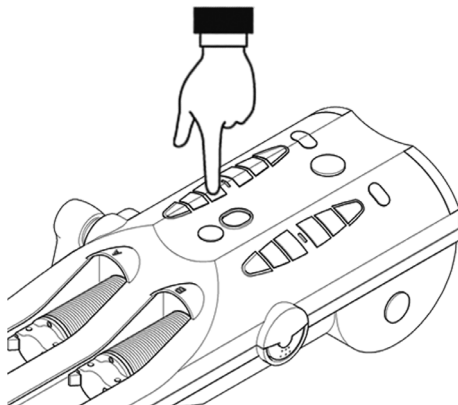

Forward Movement

Pressing a forward button moves the ram forward at the selected speed.

◀◀ fast

If the pressure exceeds approximately 40psi when the ram is moving forward fast it will automatically stop.

◀ medium ◁ slow

(The ram stops automatically when 10mL have been injected at the slow or medium speed)

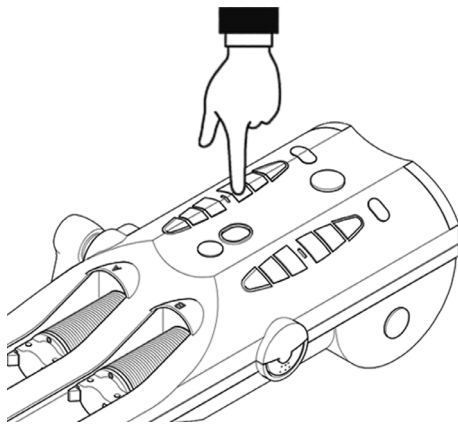

Reverse Movement

Pressing a reverse button moves the ram in reverse direction at the selected speed.

▶▶ fast

▶ medium ▷ slow

(The ram stops automatically when 10mL has been retracted at the slow or medium speed)

Note: To fill syringes take advantage of the Auto Return feature.

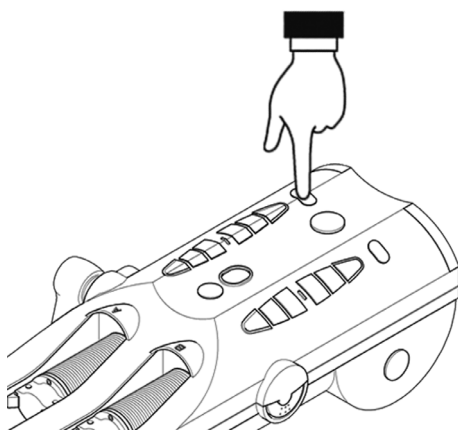

Auto Return

The rams automatically perform the filling sequence after this button is pressed for 2 or more seconds. The Quick Return volumes are programmable from the control console.

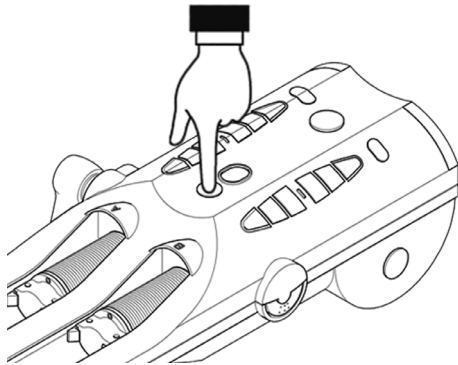

Air Check

Press this button after verifying no air is present in the syringe or tubing. If this button is not pressed, an injection cannot be performed.

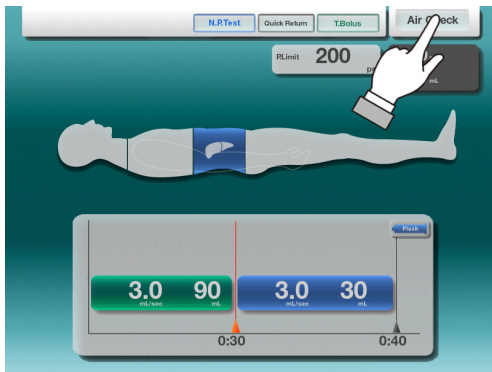

Air Check (US Version)

Pressing the Air Check button on the Console, as shown at left, shall also cause the Start OK to appear.

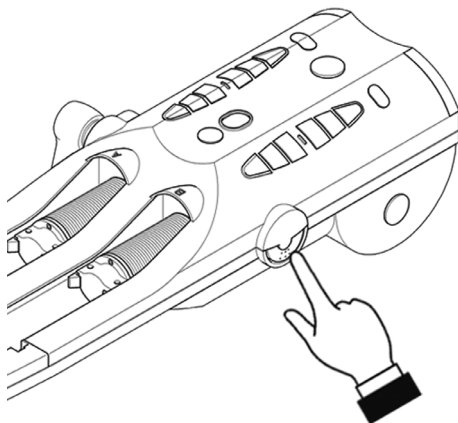

Quick Purge (US Version)

The Quick Purge feature will automatically move the Powerhead rams forward to assist in expelling remaining air. The Quick Purge is activated by pressing the button located on the side of the Powerhead as shown.

9.3.1. Starting injection from control room

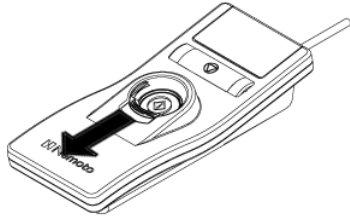

Position the Switch Box as shown, then slide the Start Button cover in the direction shown by the arrow.

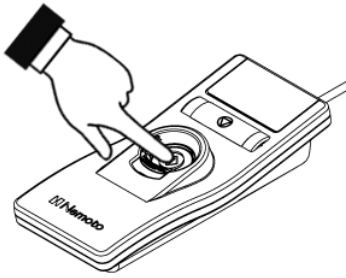

Press the now exposed green Start Button to start the injection.

Note : Pressing the Start Button during an injection will cause the injection to stop. Pressing again will restart the injection.

9.3.2. Starting injection from examination room

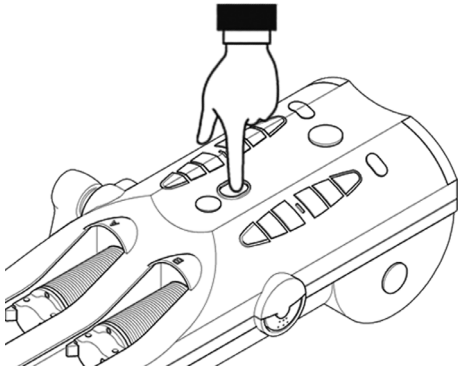

Powerhead start button

Press the start button on the Powerhead to start an injection.

Note : Pressing the start button during an injection, will stop the injection. Pressing again will restart the injection.

9.3.3. Stopping injection from examination room

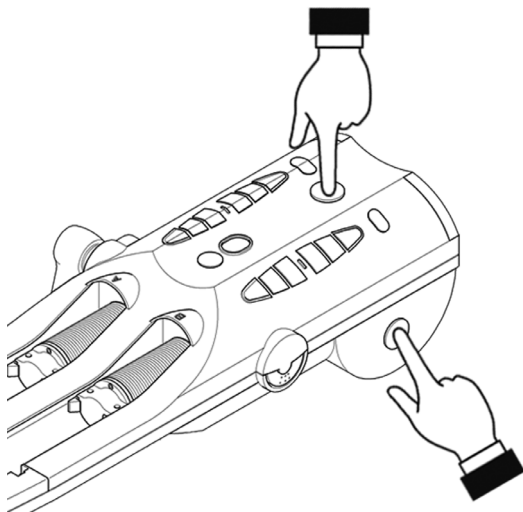

Injection stop buttons are located on both sides and atop the Powerhead.

Pressing any Stop button during an injection shall cause the injection to Stop.

(If the STOP button is setup as a HOLD button, then pressing the STOP button during an injection will cause the injection to HOLD. Pressing a START button again, either on the Powerhead or Switch Box will cause the injection to re- start.

If STOP button is setup as a STOP button, then pressing the STOP button during an injection will cause the injection to Stop completely.)

Pressing any Powerhead button other than the "Stop" or "Start" button places the injection in HOLD.

9.3.4. Stopping injection from Control Console

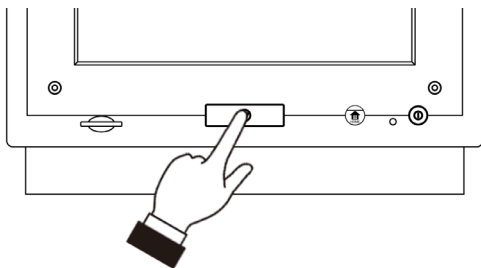

Pressing the "Stop" button on the Console during an injection stops the injection.

(If the STOP button is setup as a HOLD button, then pressing the STOP button during an injection will cause the injection to HOLD. Pressing a START button again, either on the Powerhead or Switch Box will cause the injection to re- start.

If STOP button is setup as a STOP button, then pressing the STOP button during an injection will cause the injection to Stop completely.)

9.3.5. Stopping injection from Switch Box

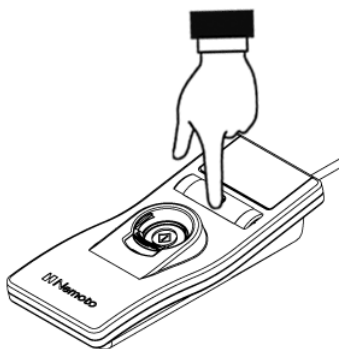

Pressing the Switch Box stop button stops the injection.

(If the STOP button is setup as a HOLD button, then pressing the STOP button during an injection will cause the injection to HOLD. Pressing a START button again, either on the Powerhead or Switch Box will cause the injection to re- start.

If STOP button is setup as a STOP button, then pressing the STOP button during an injection will cause the injection to Stop completely.)

9.3.6. Stopping Injection from Touchscreen

Touching any point on the Control Console touchscreen during an injection will put the injection into the injection HOLD status. Pressing a Start button on the Powerhead or the Switch Box will re-start the injection.

9.3.7. Air Check Cancel

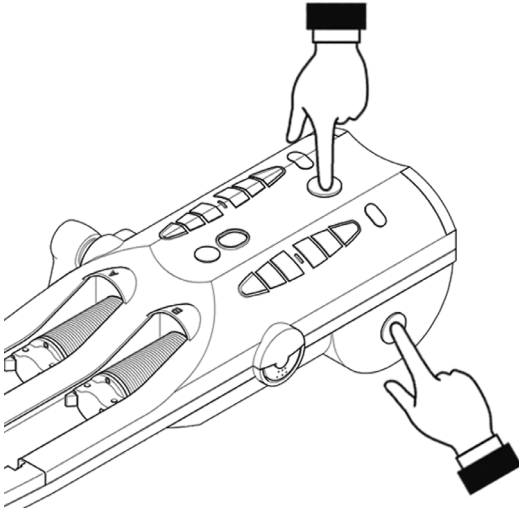

Air check cancel from the Powerhead.

Air check will be canceled when a Powerhead stop button or A-side reverse button is pressed, pulling the ram back.

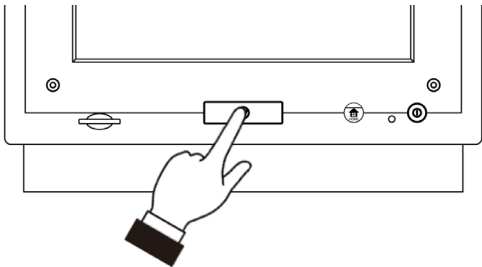

Air check cancel from the Console.

Air Check will be cancelled when the stop button of the Control Console is pressed.

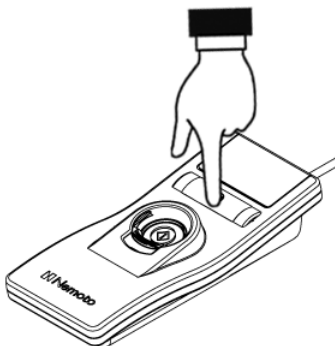

Air Check cancel from the Switch Box.

Air Check will be cancelled when the "Stop" button of the Switch Box is pressed.

- To resume injecting, press AIR CHECK, then START on Powerhead or Switch Box.
- When an injection is placed into HOLD, Console screen will display HOLD status.

9.4. Console Operation

The Console displays consist of a color graphical user interface operated via a touchscreen interface.

9.4.1. Basic Operation

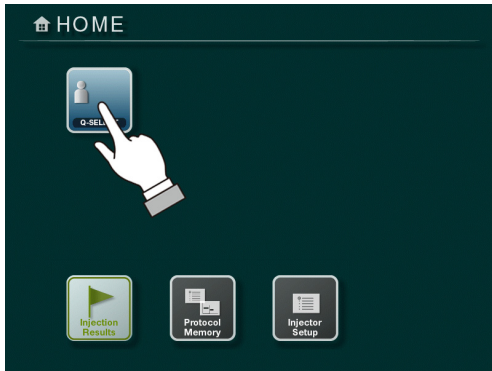

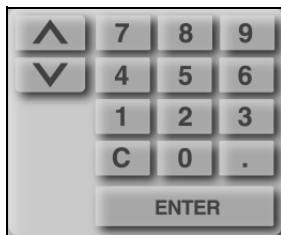

- Pressing any of the icon items on the user interface will cause the icon to highlight and become active.

9.4.2. 10-Key Keypad Operation



The keypad shown on the left is used for value entries.

Pressing the Up  arrow will cause the value to increase and pressing the Down  arrow will cause the value to decrease.

- Values can also be entered via the numeric keys. After the desired value is set, pressing the ENTER key will cause the new value to be entered.

9.4.3. HOME Screen

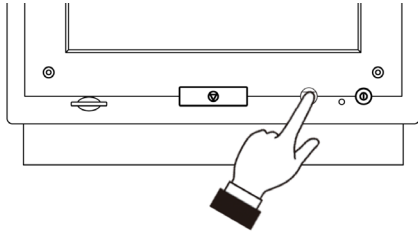

Pressing the HOME button on the Console front panel will cause the screen display to return to the Home screen shown in 9.4.1.

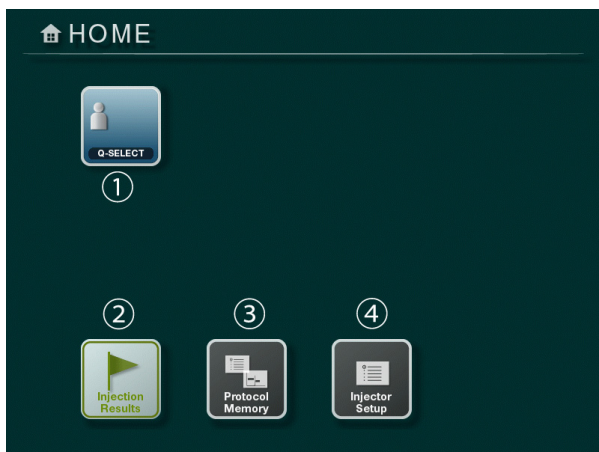

① User

The top row icons show the currently defined users for the system.

② Injection Results

Shows the history of the injections performed.
(⇒ "16. Injection Results Screen" section on Page67)

③ Protocol Memory

Accesses the protocol memory
(⇒ "12. Protocol Memory" section on Page48)

④ Injector Setup

Setup for date, time and sounds
(⇒ "18. Injector Setup" section on Page73)

9.5. Insertion and Removal of a Syringe and Adapter

Warning

To prevent syringes from becoming disengaged during an injection make sure to follow all insertion and locking instruction described in this Operation Manual. Failure to follow the instructions provided may present a hazardous situation for the patient and operator and could lead to damage to the equipment.

9.5.1. Insertion of Syringe Adapters

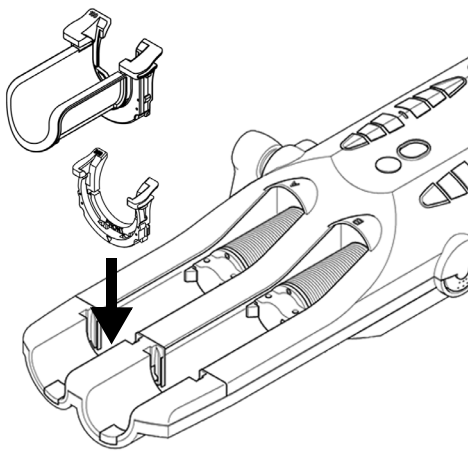

The syringe adapters of the DUAL SHOT alpha7 insert into the Powerhead identically regardless of whether it's a 200mL or 100mL adapter. The adapter simply slides into the Powerhead syringe pocket.

Ensure it is pressed down firmly until a clicking or latching sound is heard.

9.5.2. Removal of Syringe Adapter

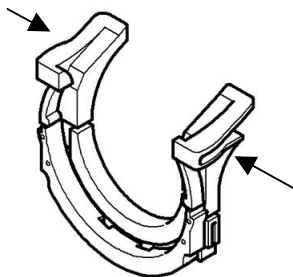

To remove a syringe adapter, squeeze the adapter in the direction of the arrows as shown in the diagram on the left. After squeezing inward, lift the adapter from the syringe pocket area of the Powerhead.

9.5.3. Insertion of Syringe into Adapter

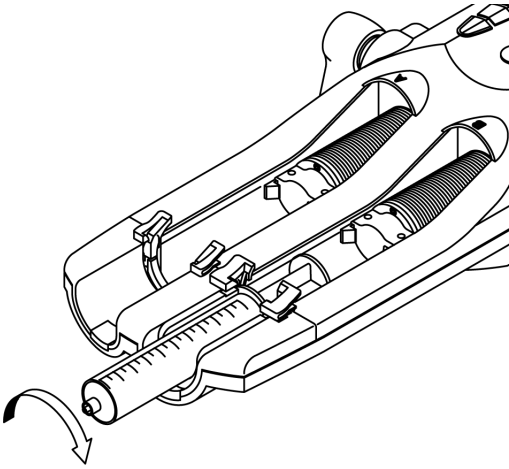

The syringe must be aligned and pushed into the slot of the adapter for proper insertion. Proper alignment consists of aligning the flat sides of the syringe with the adapter slots and ensuring the syringe notch is pointing upwards.

After the syringe is inserted into the adapter slots, rotate clockwise or counterclockwise until the syringe locks into place.

9.5.4. Removal of Syringe from Adapter

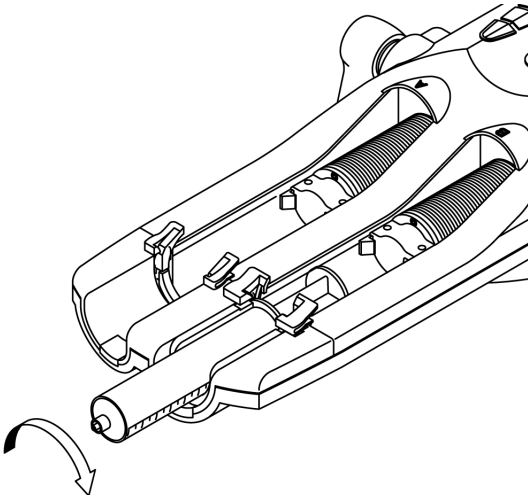

To remove the syringe from the adapter, first rotate the syringe either clockwise or counter-clockwise until the flat sides of the syringe are aligned with the adapter.

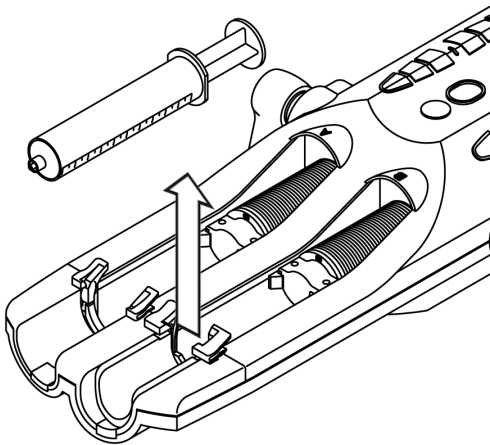

After aligning the syringe lift upwards and remove the syringe from the syringe pocket.

9.6. Syringe Filling

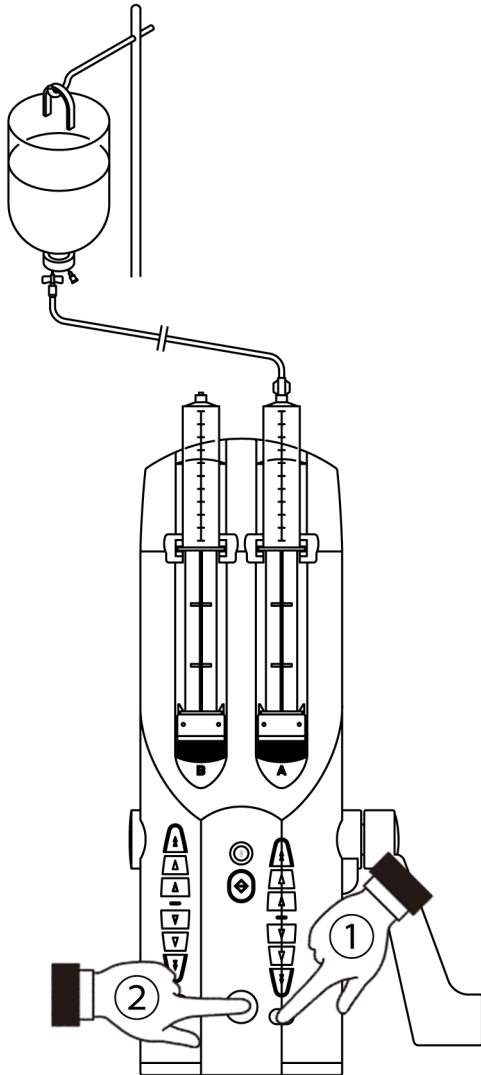

Filling of Contrast or Saline

Tilt the Powerhead so the syringe tips are pointing upward.
Connect the syringes to the media supply.

Press the Auto-Return button ① for 2 or more seconds to start the Quick Return process.

Quick Return Process

Quick Return Process will automatically move and stop the ram movement to the preset filling volume setting.

For detail, refer to "15. *Quick Return*" section on Page66 for the Quick Return setting.

Press the "Stop" button ② at anytime to stop the ram motion.

Disconnect the tubing from the syringes when complete.

9.7. Connection of the injection line

After completing the filling sequence, connect the Y-tubing to the injector syringes as shown in the below diagram. After connecting tubing the air must be purged from the syringes and tubing. If the injection is for contrast only, a minimum of 6mL forward motion must be detected. In the case of contrast and saline injection, a minimum of 2mL forward motion on the A-side must be detected and 4mL on the B-side. The DUAL SHOT alpha7 provides two methods to assist users in purging air.

Quick Purge (US Version)

The Quick Purge sequence has been designed specifically for use with the manufacturers recommended consumables. The Quick Purge sequence can be used for either single syringe configurations or dual syringe configurations. To activate the Quick Purge sequence, press the button on the side of the Powerhead to start.

Quick Purge Sequence will move both A-side and B-side simultaneously to the preset volume. Refer to Configuration - "18.7. Quick Purge Volume Set" section on Page 76 section for setting up the default values for the Quick Purge feature.

Manual Purging (US / EU Version)

1. A-side: After filling, connect the female connector of tubing to the syringe. Using the forward buttons to push contrast to the junction of the Y-connector.
2. B-side: After filling, connect the tubing with one-way check valve to the saline syringe. Using the forward buttons push saline, removing remaining air to the distal end of tubing.

Note: To properly remove air, be sure syringe tips are pointing upwards.

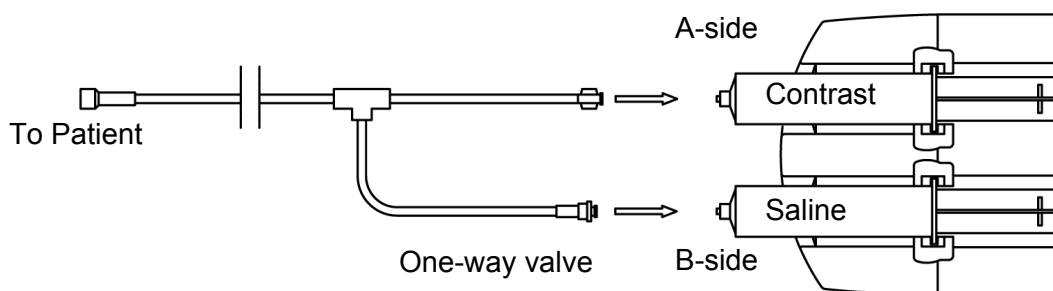

IMPORTANT:

Verify syringe and tubing connections are secure before proceeding. Unsecured connections may become disconnected if not properly secured.



Observe and practice good clinical technique to ensure sterility and removal of air from all syringe and tubing connections.

10. Operation Procedure

1) Setup injection protocol

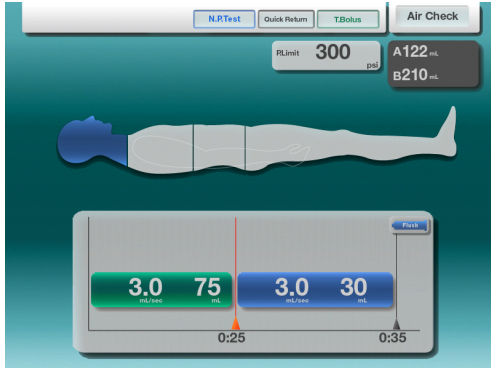

Program the desired protocol for the examination.

For protocol mode programming explanations reference page 42 "11. Flow Rate Mode".

2) Prepare syringes and tubing for injection

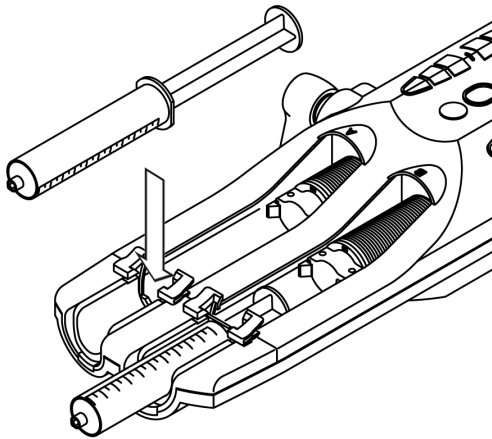

An examination using both A and B sides is shown as an example.

Using the techniques described earlier, install, fill and purge a contrast syringe on the A-side and a saline syringe on the B-side.

3) Secure the syringes in the Powerhead

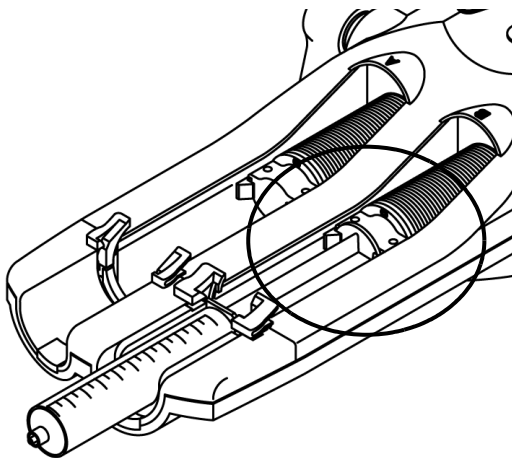

Securely lock the ram clasper onto the syringe plunger. Closely contact the ram with the flange of the plunger.

4) Connect the injection line.

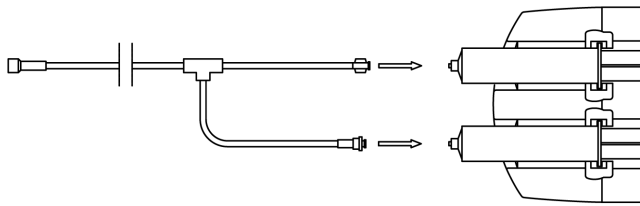

Connect the injection line to the syringe.
Refer to "Connecting the Injection Line" for details.

5) Purge the syringe and tubing

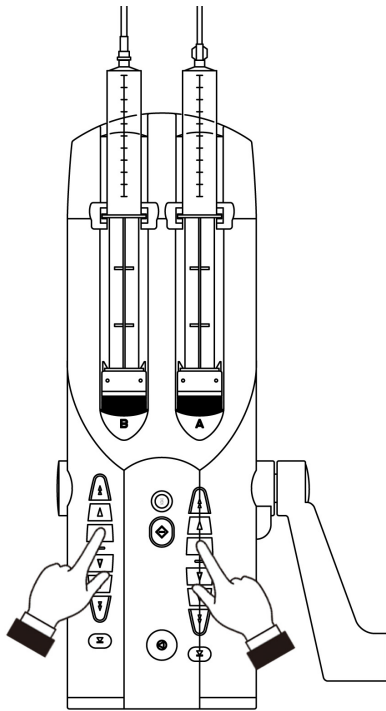

Using the techniques described in the "Connection of the injection line" section purge and remove air from the syringes and tubing.

Whether the Quick Purge feature or manual method is used to evacuate air, remember these are only aids to good clinical practice.

6) Confirmation of air removal

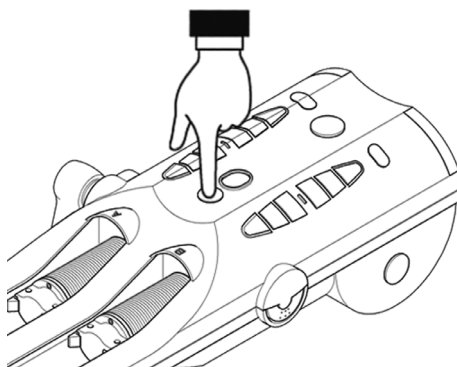

Inspect syringe(s) and tubing to verify that air has been removed. To confirm to the injector that you have removed air, press the Air Check button on the Powerhead.

US VERSION

NOTE: If an air purge sequence, either manually or via the Quick Purge feature is not completed, the system cannot be made Ready for an injection.

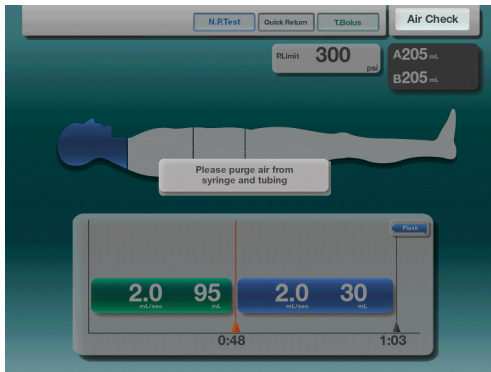

In the event the Air Check is attempted without first performing an air purge sequence the message on the left will be presented to the user.

7) Injector "Not Ready" and "Start OK"

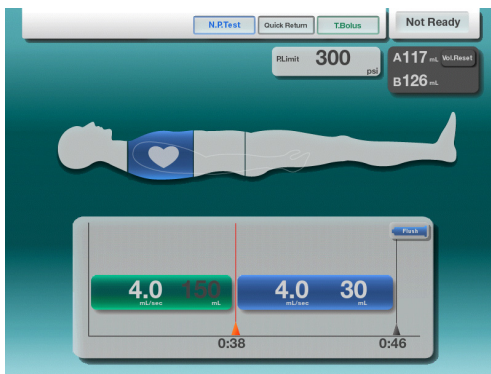

After the user confirms no air is present in the system, it is still possible conditions are not sufficient for the injection to start. If "Air Check" has been pressed, but the injection cannot be performed, a "Not Ready" state will be presented to the user. The "Not Ready" state appears as a blinking "Not Ready" in the upper right corner of the display.

Note: In the example here, the volume is insufficient for the A-side injection.

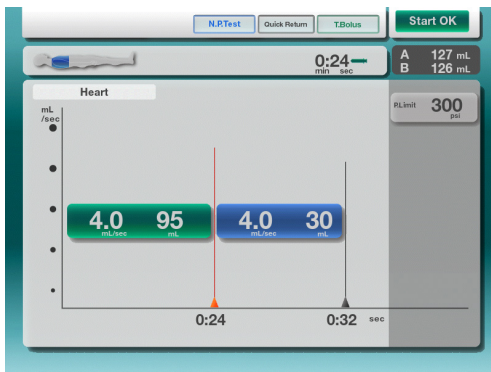

Confirm the status "Start OK" is displayed in the upper right hand corner of the Control Console display.

If "Start OK" is not displayed, check settings of injection protocol and syringe volumes.

The following operations will cancel the "Start OK" status prohibiting the injection start.

- Pressing a Reverse or Forward button
- Pressing an Auto-Return button
- Pressing a Stop button

8) Starting an Injection

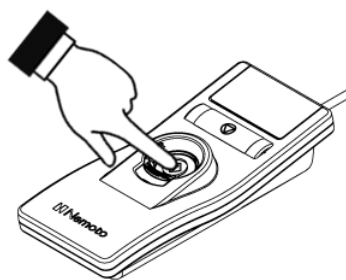

An injection can be started in the control room by pressing the Start button on the Switch Box or by pressing the Start button located on the Powerhead.

If the Start button is pressed during an injection, the injection will stop. When the start button is pressed again, the injection will continue.

9) Low Pressure Warning



A low pressure monitoring system is designed in the injector for the A-side and B-sides. The message at the left will be displayed when a low pressure condition exists. Low pressure sensing aids in detecting an empty syringe. Refer to the following table for understanding when a low pressure condition exists.

Low Pressure Warning

PRESSURE	FLOW RATE	ACTION
Low pressure	0.1 - 1.4 mL/sec	Warning message appears, injection continues
A-side < 4PSI	1.5 - 10.0 mL/sec	Warning message appears and injection stops after 10mL are injected
B-side < 10PSI	0.1 - 1.9 mL/sec	Warning message appears, injection continues
B-side < 10PSI	2.0 - 10.0 mL/sec	Warning message appears and injection stops after 10mL are injected
<p>Caution:</p> <p>Low pressure warning feature for B-side is only active if the following conditions are satisfied.</p> <ol style="list-style-type: none"> 1. Any injection mode in which a B-side injection follows a A-side injection. 2. When the actual pressure for the A-side exceeds 14 PSI. 		

If a low pressure warning message is displayed, check the syringe, tubing and needle for air, proper connections, etc.

Danger

The injector does not automatically check for extravasations. Exercise good clinical practice and monitor the injection site. In the event extravasations are identified, stop the injection immediately and correct.

10) Injection in Process

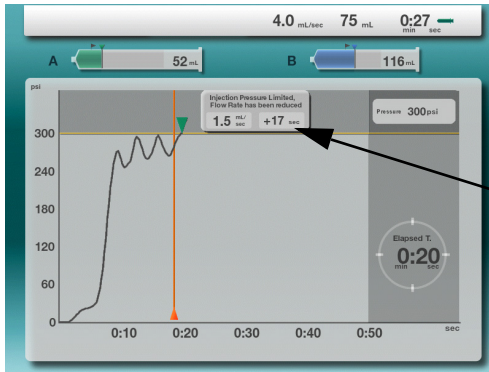

During an injection a screen similar to the one on the left will be displayed. A real-time pressure graph will be shown during the injection.

In the event pressure limit is reached, a message will be presented indicating Pressure Limit is activated.

11) Injection Stopped

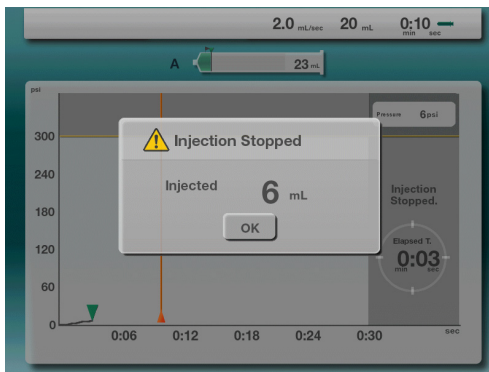

If the Stop button is pressed during an injection, the injection will stop.

Press "OK" to return to the idle screen.

11. Flow Rate Mode

11.1. Screen Explanation

Setup Screen

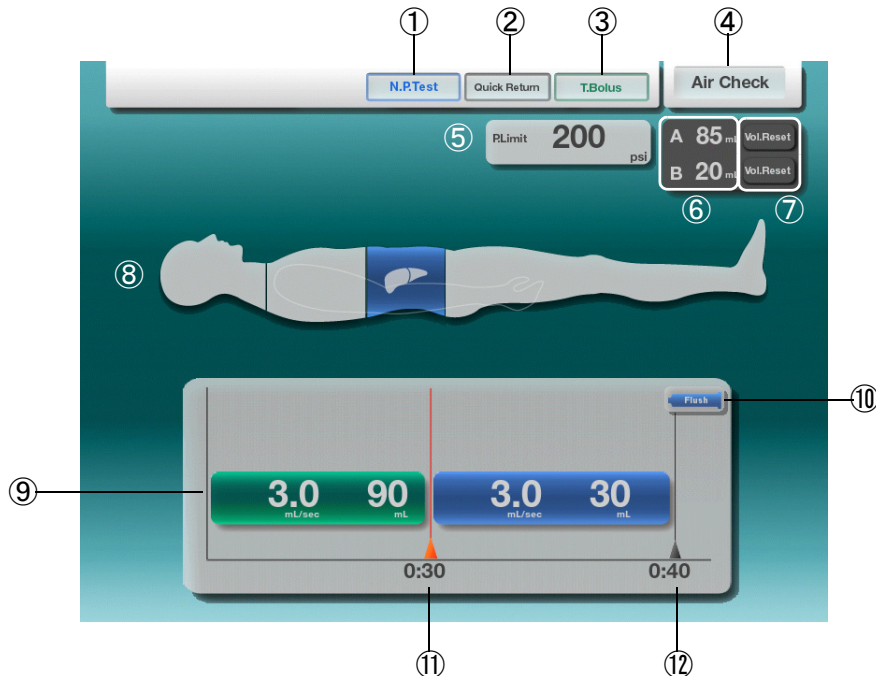

① N.P. Test

Needle Placement Test. Press to access and perform test.

② Quick Return

Press to access and program the Quick Return function.

③ T.Bolus

Press to access T.Bolus injection pop-up window and to perform T.Bolus injection.

④ Injection Status Indication

Indicates status such as Air Check, Start OK, etc.

⑤ P.Limit

Press to set the desired pressure limit for the injection protocol.

⑥ Syringe Information

Display of remaining volume and the syringe size for the A-side and B-side.

⑦ Vol.Reset

Sets the programmed volume of the injection protocol to the volume remaining in the

syringe.

This key only appears when the remaining volume of the syringe is less than the programmed volume.

⑧ Examination Area

Select body segment for examination area.

⑨ Injection Pattern

Display of the injection protocol. Press parameters to alter values.

⑩ Flush

Touch "Flush", when saline is not necessary after the contrast injection. Saline then will not be injected following a contrast injection.

⑪ Injection Time

Display of the time required to inject the contrast.

⑫ Injection Time

Total time expected for the contrast and saline injection.

INJECTION READY SCREEN

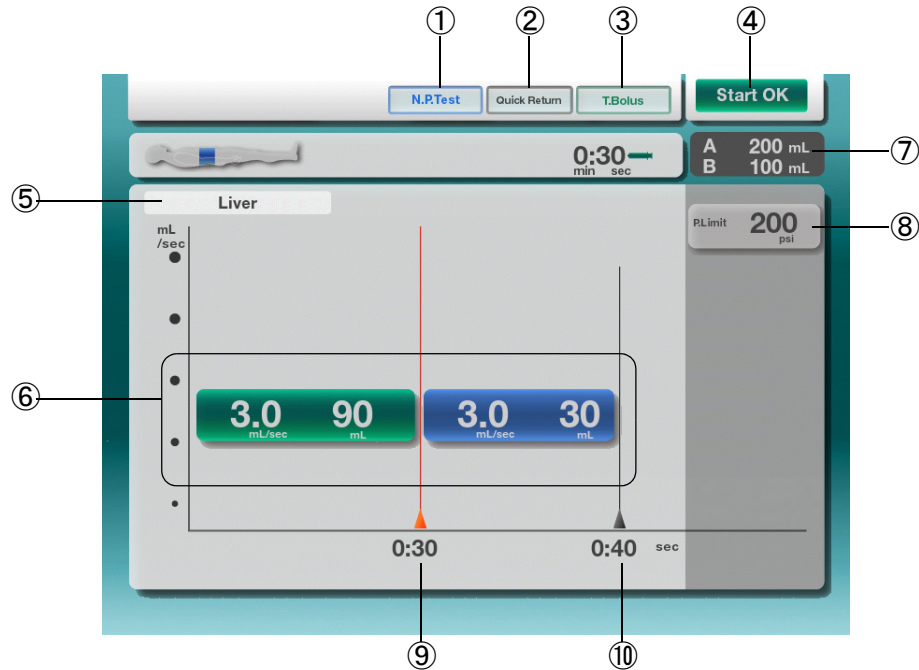
**① N.P. Test**

Needle Placement Test. Press to access and perform test.

② Quick Return

Press to access and program the Quick Return function.

③ T.Bolus

Press to access T.Bolus injection pop-up window and to perform T.Bolus injection.

④ Injection Status Indication

Indicates status such as Air Check, Start OK, etc.

⑤ Protocol Name Indication

This is the name of the currently displayed protocol if it has been saved.

⑥ Injection Pattern

Shows the protocol to be performed. Always shown in a flow rate and volume format.

⑦ Syringe Information

Display of remaining volume and the syringe size for the A-side and B-side.

⑧ P.Limit

Displays current set pressure limit. Press to change the pressure limit setting.

⑨ Injection Time

Display of the time required to inject the contrast.

⑩ Injection Time

Total time expected for the contrast and saline injection.

INJECTING / RESULT SCREEN

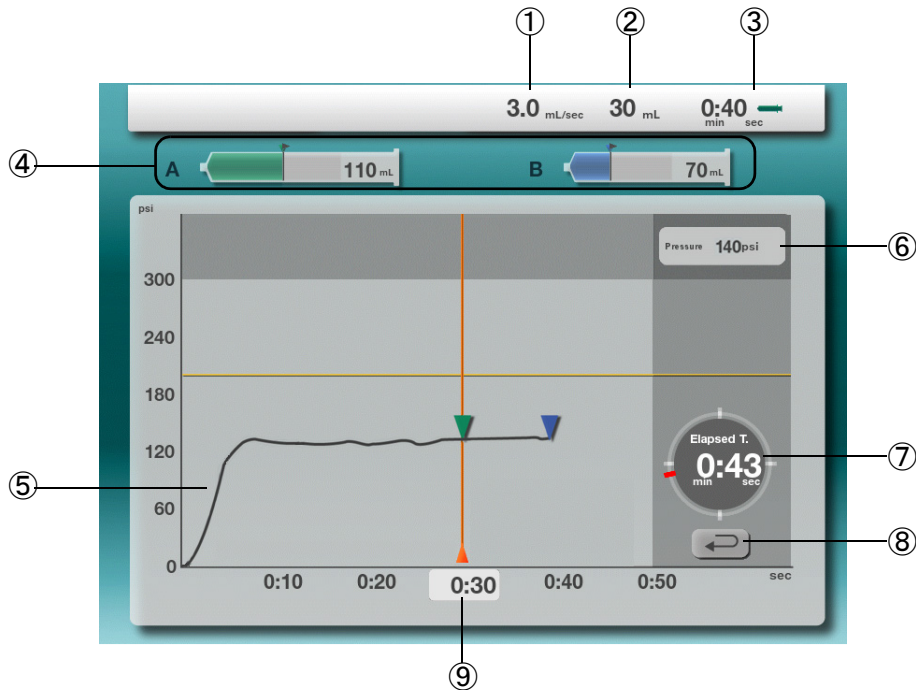
**① Injection Flow Rate**

Display the programmed flow rate for the currently injecting phase.

② Injection Volume

Display the programmed volume for the currently injecting phase.

③ Injection Time

Display the expected injection time.

④ Syringe Information

Display of remaining volume and the syringe size for the A-side and B-side.

⑤ Real-Time Pressure Graph

Display injection pressure graph in real-time.

⑥ Real-Time Pressure Display

Numerical display of pressure in real-time.

⑦ Elapsed Time Display

Displays amount of time since the start of injection.

⑧ Return Key

Press to exit the injection result display. (Appears when injection is complete)

⑨ A-Side Injection Time Display

Display the injection time for the A-side.

11.2. Protocol Setup

Protocol Setup Description.

11.2.1. Flow Rate Screen Selection

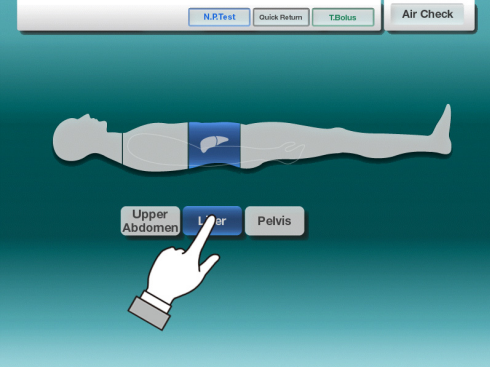

- Press the body part key as shown.

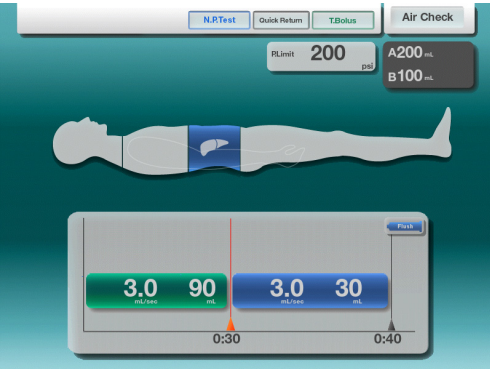

- The Flow Rate injection pattern will be presented as shown.

11.2.2. Pressure Limit Setup

Setting up the injection Pressure Limit.

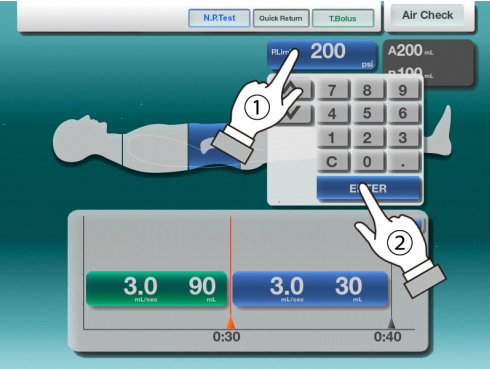

- Pressing the P.Limit key will cause the 10-key keypad to be displayed.
- Enter the desired value using the 10-key or the up/down arrow keys, then press the ENTER key. (Refer to page 31 "9.4.2.10-Key Keypad Operation" for details of keypad operation.)

11.2.3. Injection Flow Rate and Volume Setting

Setting up the injection Flow Rate and Volume.

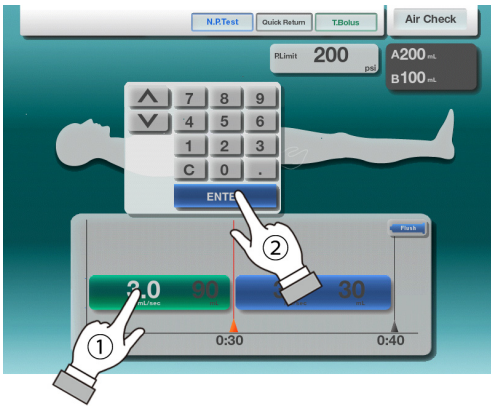

- Pressing the Flow Rate area or Volume area will cause the 10-key keypad to be displayed. The selected value will highlight for easy identification.
- Enter the desired value using the 10-key or the up/down arrow keys, then press the ENTER key. (Refer to page 31 "9.4.2.10-Key Keypad Operation" for details of keypad operation.)

11.2.4. Flush Setup

Setting up a saline flush following the contrast injection.

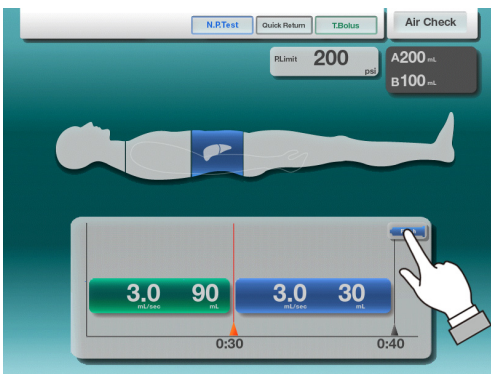

Pressing the Flush key as shown, will toggle the flush ON and OFF.

- When the Flush is ON, the key will be highlighted and the saline injection phase will be shown.
- When the Flush is OFF, the key will be dimmed and the saline injection will be hidden.

11.2.5. Volume Reset

When the syringe volume is less than the programmed volume the Vol.Reset key will appear.

- Pressing the Volume Reset key when the syringe volume is less than the programmed volume will cause the programmed value to be set to the syringe volume.

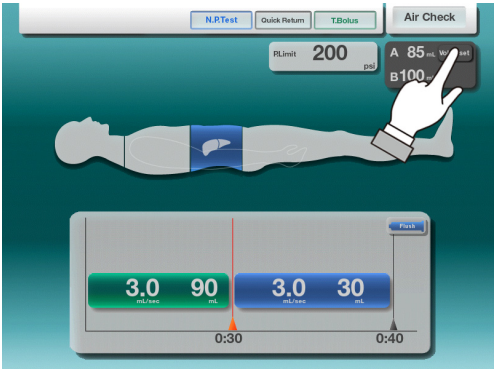

- Press the Vol.Reset key.

A-syringe remaining volume: 85mL / Programmed Volume: 90mL

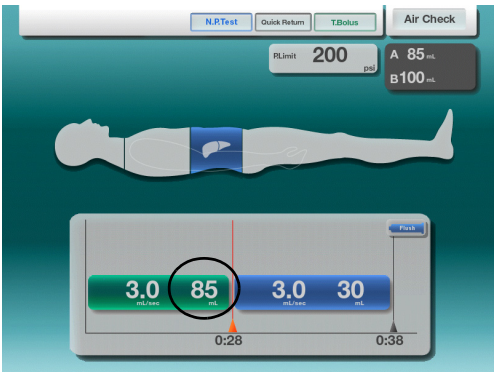

- After pressing the Vol.Reset key, the programmed volumes will be adjusted in accordance with syringe volumes.

A-syringe volume and programmed volume are equal.

12. Protocol Memory

12.1. Accessing Protocol Memory Menu

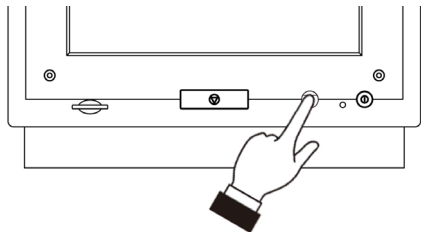

- Press the HOME button on the Console front panel.

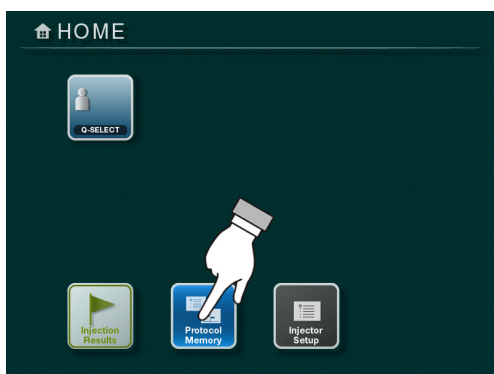

- The HOME menu will be displayed. Press the Protocol Memory key.

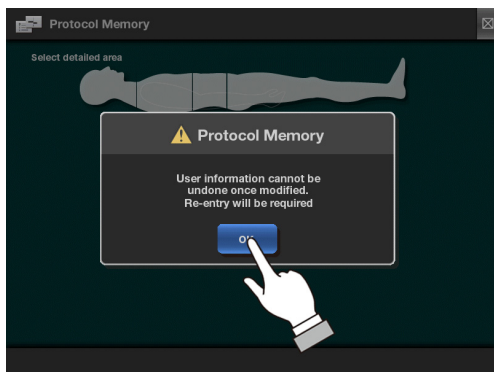

- An informational message will be presented, regarding changes to protocols. Press the OK key to continue.

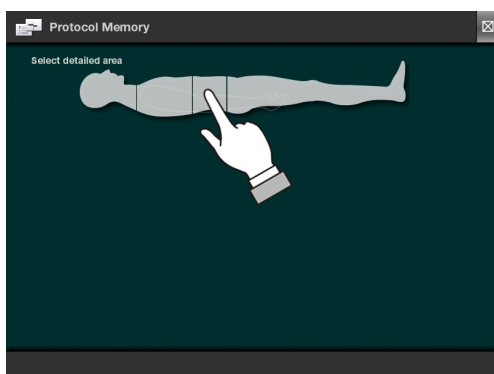

- After selecting the User, the Body Area Selection screen will be presented. Select the desired body area.

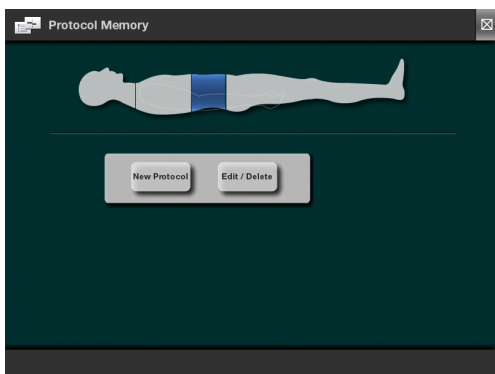

The Protocol Memory options (New Protocol, Edit/Delete) will appear.

12.2. New Protocol

Setting up a new protocol for a selected body area.

Three new protocols can be stored for each body area.

Refer to *page 48 "12.1.Accessing Protocol Memory Menu"* for details on accessing this function.

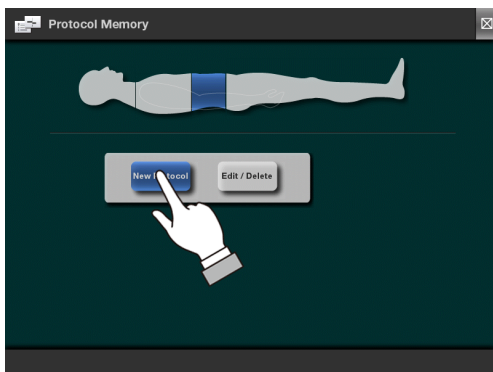

- To create a new protocol, press the New Protocol key on the menu.

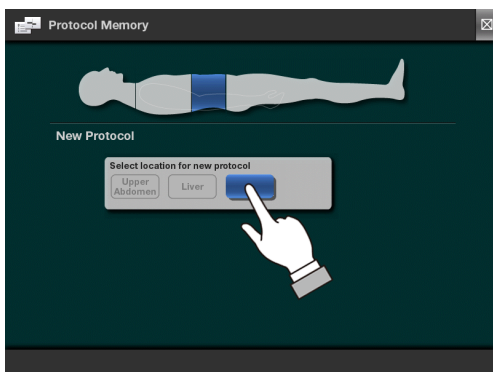

After selecting New Protocol, the protocol location selection screen will appear.

- Select the desired location to store the new protocol.

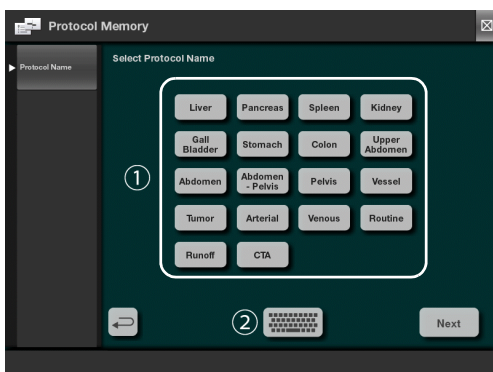

After selecting the desired location, the screen will change to allow the selection of a standard protocol name or will provide the option to enter a custom name.

- The standard list of protocol names will be as shown (1).

To enter a custom protocol name, press the keyboard button (2). For detailed information regarding the keyboard, refer to *page 63 "12.4.Alphabetic Keyboard Overview"* section.

- After the protocol name is set, press the Next button in the lower right-hand of the display.

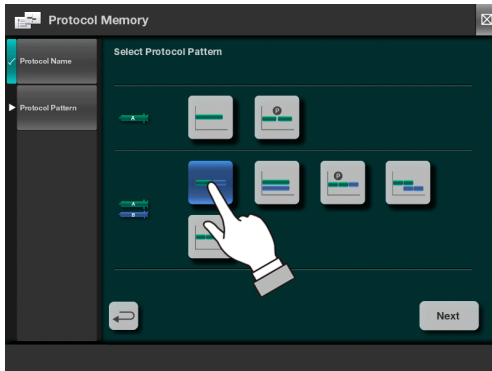

- Before this step, be sure to enter the protocol name as previously described.
- Select the desired protocol pattern.
- Press Next button to continue.

Injection Pattern List:

EU Version	US Version
A	A
A → A → A → A → A	A → Pause → A
A → Hold → A	A → B
A → B	A+B
B → A → A+B → B	A → Pause → A → B
A+B → B	A → A+B → B
A → A → A → A → B	A → A → B
A → Pause → A → B	
A → A+B	
A → A+B → B	

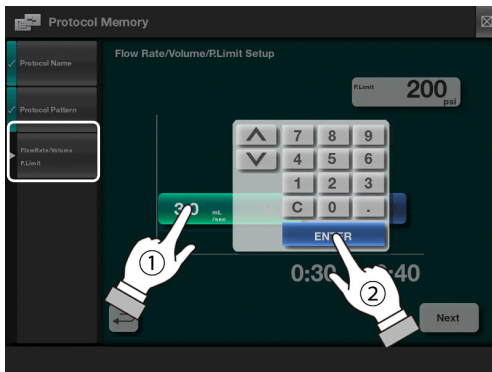

- Once the protocol pattern is fixed, the Flow Rate and Volume parameters can be set.
- Select the Flow Rate or Volume parameter by pressing the corresponding area. The 10-key keypad will appear. Enter the desired value using the 10-key or the up/down arrow keys, then press the ENTER key. (Refer to *page 31* "9.4.2.10-Key Keypad Operation").
- Press the Next key to continue.

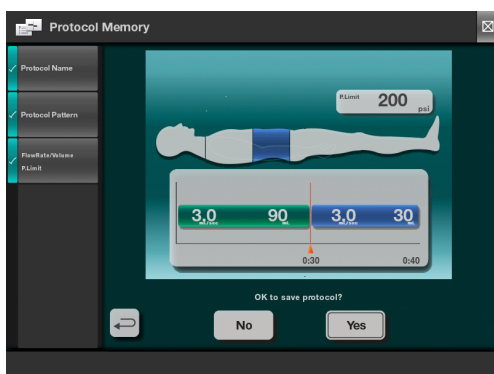

- The protocol confirmation screen will be presented before the protocol is saved
- To save the protocol, press the Yes key.

Press the No key, to return to the protocol setup.

The protocol cannot be modified on this screen.

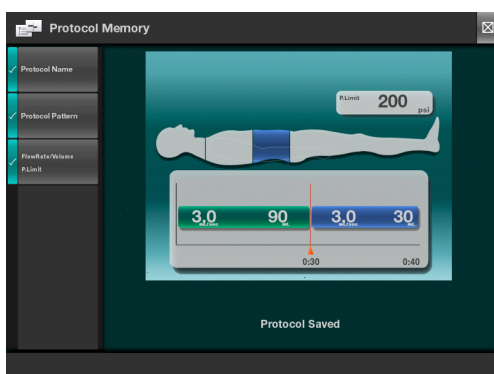

- Pressing Yes (to save) on the previous screen will store the protocol in memory. A saved confirmation will be shown briefly.

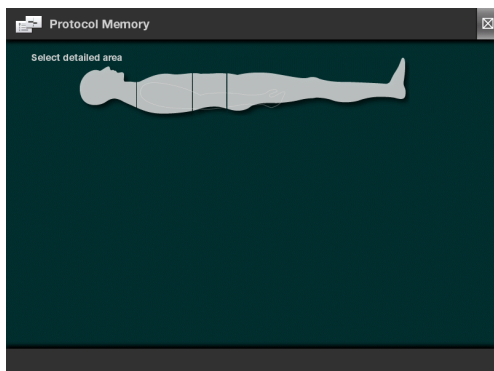

- The screen will then transition back to the initial protocol setup screen.
- To set up a new protocol, select the desired body area.
- To present the HOME screen, press the HOME button of the Console.

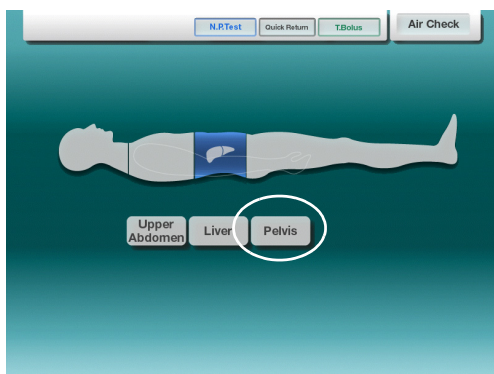

The newly created protocol will be shown. Press the corresponding button to access the protocol.

12.3. Edit / Delete Protocol

An existing protocol can be edited or deleted as follows.

To access Edit/Delete Protocol refer to *page 48 "12.1.Accessing Protocol Memory Menu"* section.

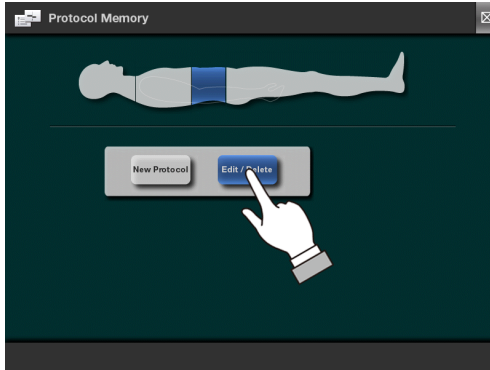

- Press the Edit / Delete key on the Protocol Memory menu.

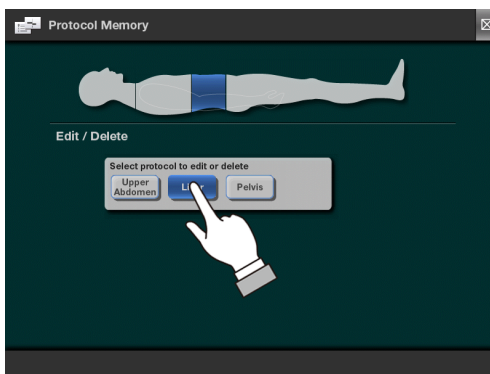

The currently available protocols will appear.

- Select the desired protocol to edit or delete.

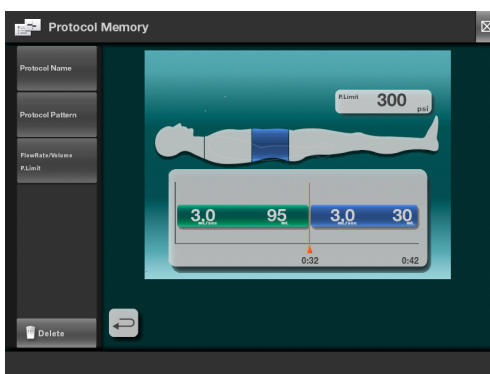

The selected protocol summary screen will be displayed. Based on the item that is desired to be modified press the appropriate menu item on the left.

- To modify the Protocol Name refer to *page 54*.
- To modify the Protocol Pattern refer to *page 56*.
- To modify the injection details refer to *page 59*.
- To delete an injection refer to *page 61*.

12.3.1. Modifying the Protocol Name

The selected protocol summary screen will be displayed.

To access this function refer to *page 53 "12.3.Edit / Delete Protocol"* section.

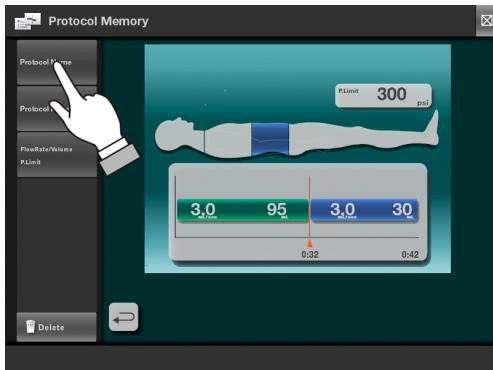

- Select the Protocol Name from the left-side menu.

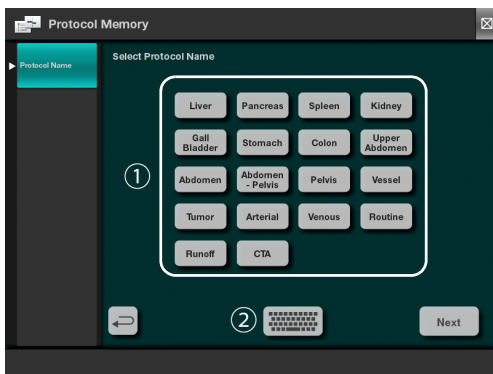

Pressing the Protocol Name key will cause the Select Protocol Name screen to appear.

- To set a new name for the protocol select a standard name from the list (1) or use the keyboard (2) to enter a custom name.

For information on using the keyboard function, refer to *page 63 "12.4.Alphabetic Keyboard Overview"* section.

- Press the Next key to return to the protocol summary screen.

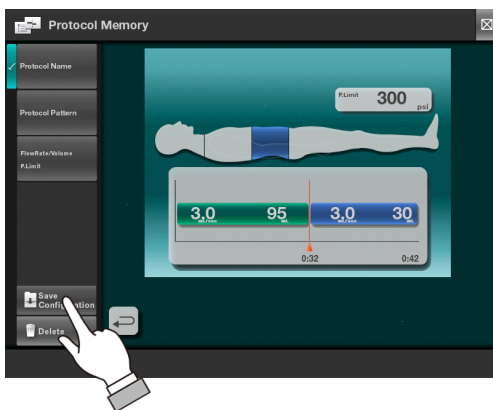

- Press the Save Configuration key on the left-side menu as shown.

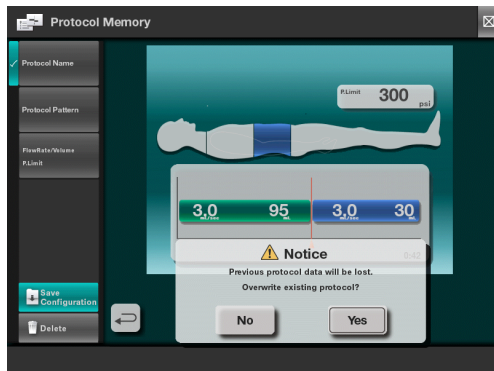

- Press the Save Configuration key on the left-side menu as shown.

To save the protocol, press the Yes key.
Press the No key, to return to the protocol setup.

Press Yes to confirm overwriting the previous version of the protocol.

Notice: This cannot be undone.

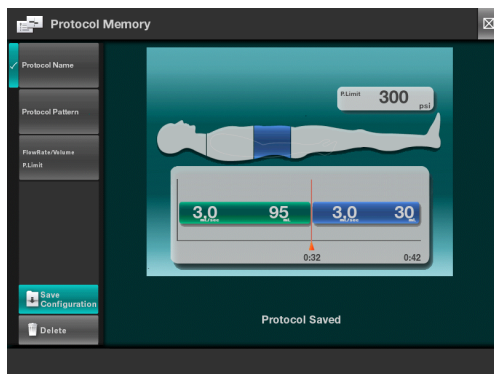

- A brief confirmation message of the saved protocol will be displayed then the screen will then transition back to the initial protocol setup screen.

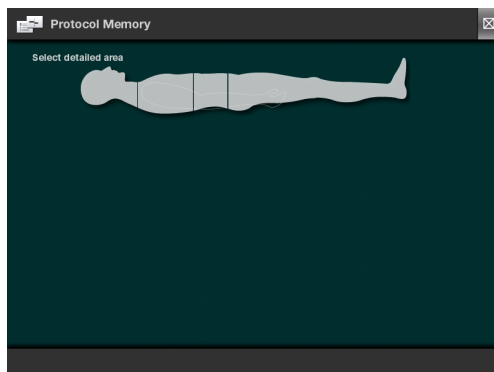

- The screen will return to the main protocol screen.
- To set up a new protocol, select the desired body area.
- To present the HOME screen, press the HOME button of the Console.

12.3.2. Modifying the Protocol Pattern

The selected protocol summary screen will be displayed.

To access this function refer to page 53 "12.3.Edit / Delete Protocol" section.

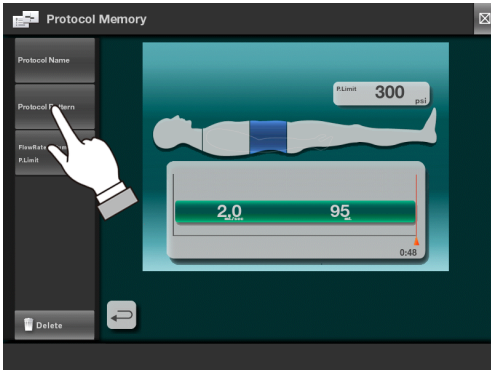

- Select the Protocol Pattern from the left-side menu.

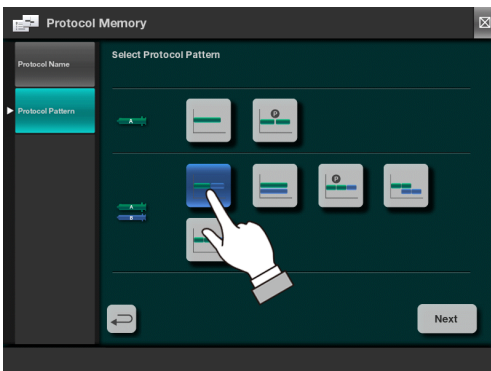

- Select the desired protocol pattern.
- Press Next button to continue.

Injection Pattern List:

EU Version	US Version
A	A
A → A → A → A → A	A → Pause → A
A → Hold → A	A → B
A → B	A+B
B → A → A+B → B	A → Pause → A → B
A+B → B	A → A+B → B
A → A → A → A → B	A → A → B
A → Pause → A → B	
A → A+B	
A → A+B → B	

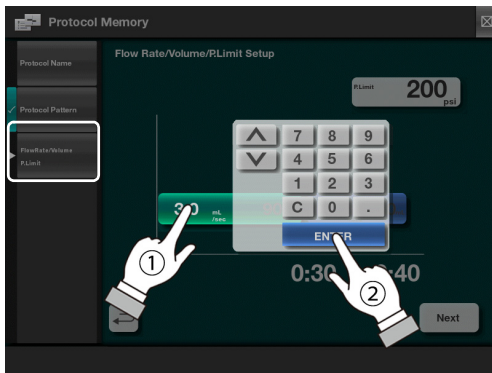

- Once the protocol pattern is fixed, the Flow Rate and Volume parameters can be set.
- Select the Flow Rate or Volume parameter by pressing the corresponding area. The 10-key keypad will appear. Enter the desired value using the 10-key or the up/down arrow keys, then press the ENTER key. (Refer to *page 31* "9.4.2.10-Key Keypad Operation").
- Press the Next key to continue.

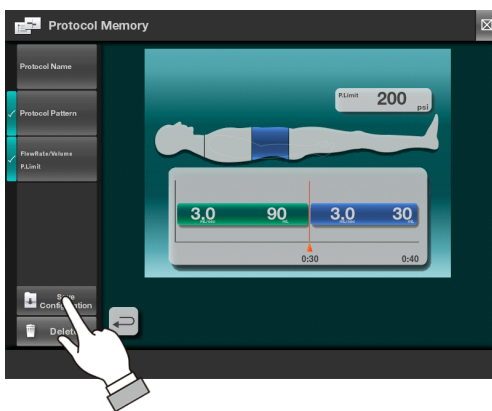

- Press the Save Configuration key on the left-side menu as shown.

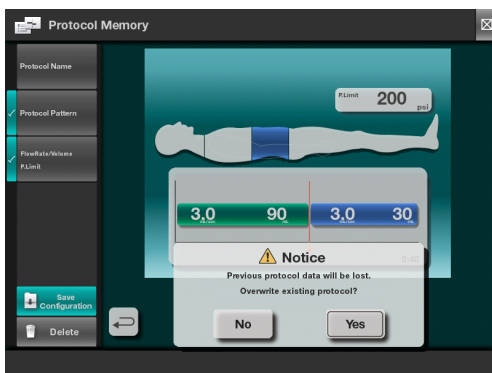

- The protocol confirmation screen will be presented before the protocol is saved.

To save the protocol, press the Yes key.
Press the No key, to return to the protocol setup.

Press Yes to confirm overwriting the previous version of the protocol.

Notice: This cannot be undone. The previous protocol data will be overwritten.

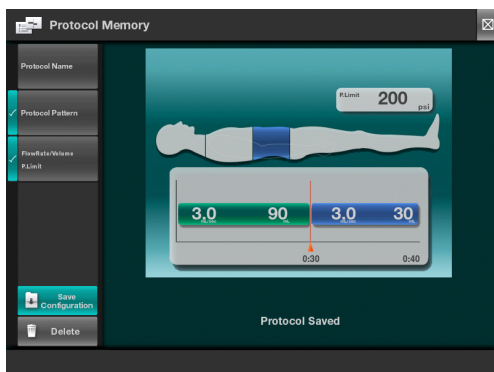

- A brief confirmation message of the saved protocol will be displayed then the screen will then transition back to the initial protocol setup screen.

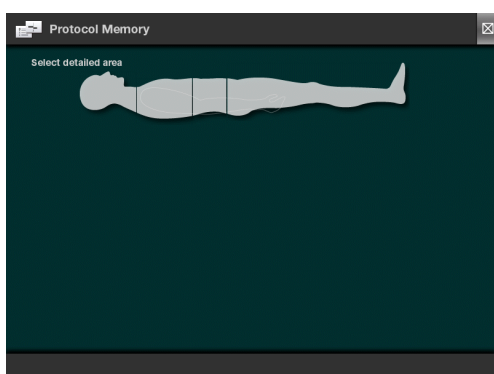

- The screen will return to the main protocol screen.
- To set up a new protocol, select the desired body area.
- To present the HOME screen, press the HOME button of the Console.

12.3.3. Modifying the protocol details

The selected protocol summary screen will be displayed.

To access this function refer to *page 53 "12.3.Edit / Delete Protocol"* section.

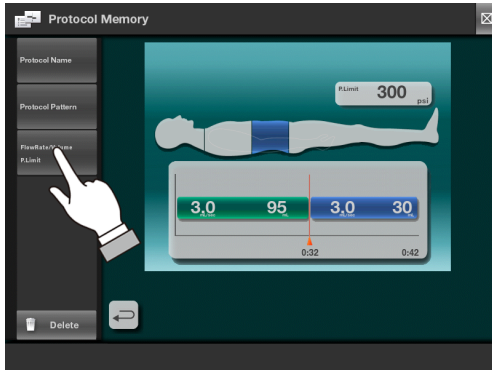

- Select the body weight parameter settings from the left-side menu.

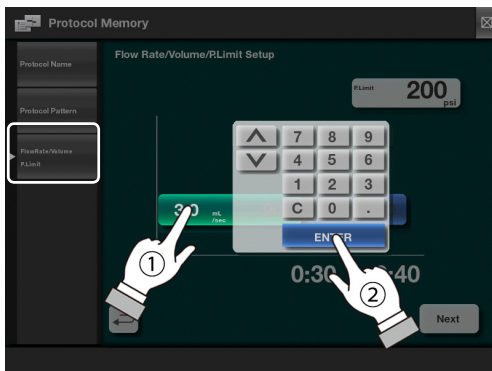

- Select the Flow Rate or Volume parameter by pressing the corresponding area. The 10-key keypad will appear. Enter the desired value using the 10-key or the up/down arrow keys, then press the ENTER key. (Refer to *page 31 "9.4.2.10-Key Keypad Operation"*).
- Press the Next key to continue.

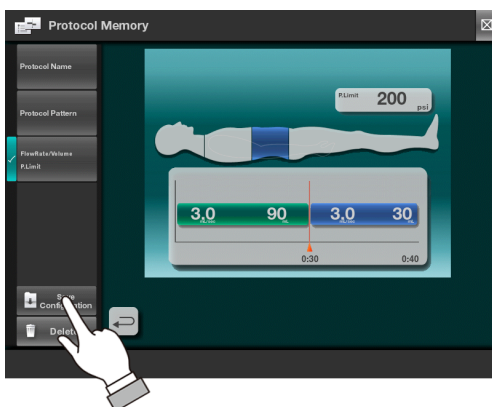

- Press the Save Configuration key on the left-side menu as shown.

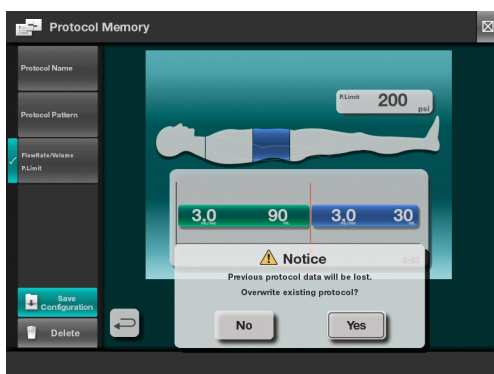

- The protocol confirmation screen will be presented before the protocol is saved.

To save the protocol, press the Yes key.
Press the No key, to return to the protocol setup.

Press Yes to confirm overwriting the previous version of the protocol.

Notice: This cannot be undone. The previous protocol data will be overwritten.

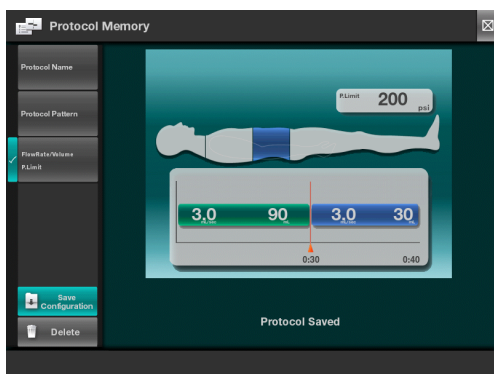

- A brief confirmation message of the saved protocol will be displayed then the screen will then transition back to the initial protocol setup screen.

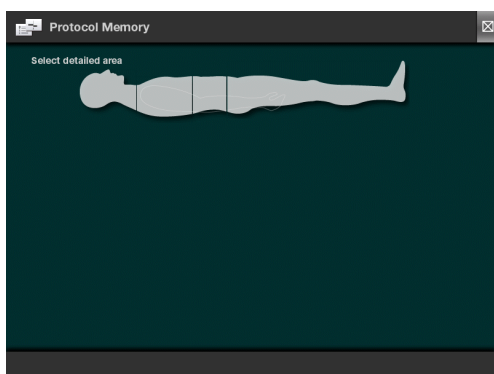

- The screen will return to the main protocol screen.
- To set up a new protocol, select the desired body area.
- To present the HOME screen, press the HOME button of the Console.

12.3.4. Delete Protocol

Select the protocol to be deleted, the selected protocol summary screen will be displayed.
To access this function refer to page 53 "12.3.Edit / Delete Protocol" section.

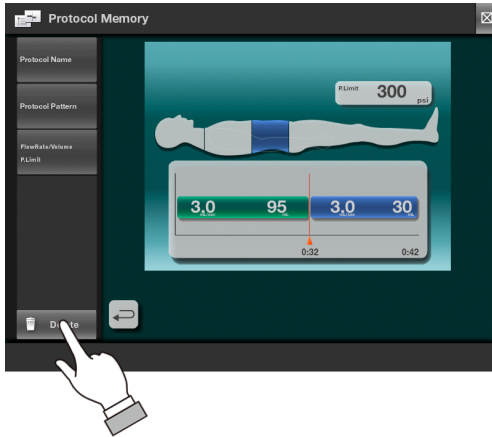

- Select the Delete key (1) as shown in the left-side menu.

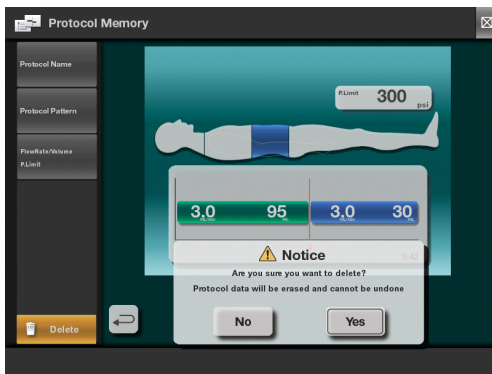

- Press Yes to delete the protocol.
Press No to cancel and keep the protocol.

Notice: The delete protocol function permanently deletes the protocol from memory and it cannot be undone.

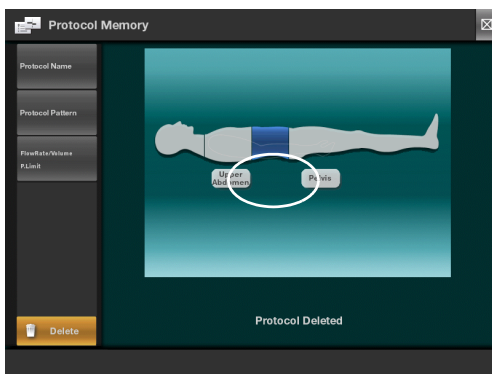

- The screen shown at the left will appear briefly indicating the Delete protocol is completed, and the protocol is removed from memory.

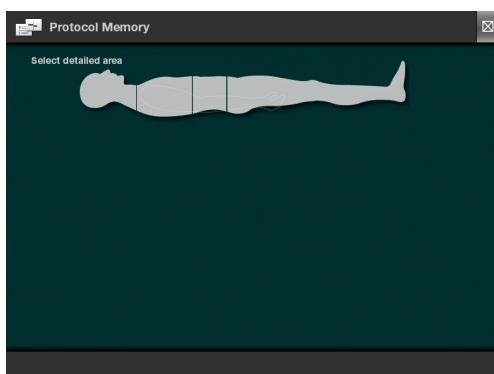

- The screen will return to the main protocol screen.
- To set up a new protocol, select the desired body area.
- To present the HOME screen, press the HOME button of the Console.

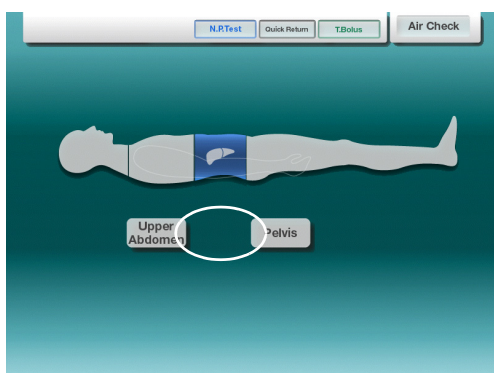

The selected protocol will be deleted.

12.4. Alphabetic Keyboard Overview

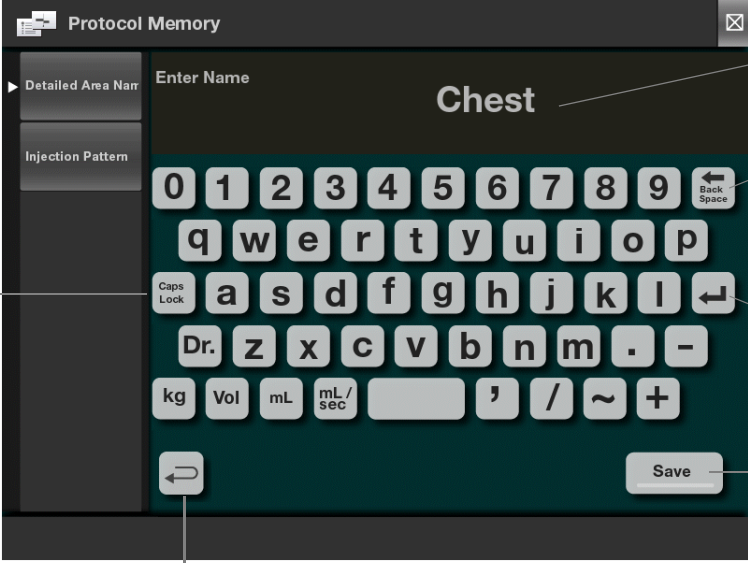

The screenshot shows the 'Protocol Memory' interface with a dark background. At the top, there's a title bar with a close button. Below it, a 'Detailed Area Name' section contains an 'Enter Name' field with the text 'Chest' entered. To the left of the keyboard is an 'Injection Pattern' section. The keyboard is a standard QWERTY layout with additional function keys like 'kg', 'Vol', 'mL', 'mL/sec', and a 'Save' button at the bottom right. Callouts point to the 'Caps Lock' key, 'Backspace' key, 'Enter' key, 'Return' key, and 'Save' key, each with a brief description of its function.

Caps Lock key
Press this key to make a alpha characters capitalized.

Protocol Name Area

Backspace Key
Use this key to delete one character at a time, starting from the last character typed.

Enter Key
Press this key to enter a second line

Save Key
Press this key to save this name for the protocol.

Return Key
Press this key cancel the name entry and return to previous screen.

- Typed characters will appear in the Protocol Name Area as entered.
- After the protocol name is entered, press the Save key to complete.

SUPPLEMENTAL EXPLANATION

- [Caps Lock] key allows changing between upper case and lower case characters.
- Enter key is used to create a second line of text for the protocol name
- The protocol name can have one or two lines, each having 16 characters.
- If an incorrect character is entered, use the Backspace key to delete the last character.
- To cancel the protocol name entry, press the Return key.

13. Needle Placement Test

The Needle Placement Test (NPT) is provided as an aid to the medical professional for checking the patency of the vein, catheter, etc. before the injection process. To access the NPT press the N.P.Test key located at the top of the Console display.

The Needle Placement Test (N.P.Test) values are automatically set to the values set on the Injector Setup screen for T.Bolus/N.P.Test. Refer to *page 75 "18.4.T.Bolus / N.P.Test"*.

These parameters will be displayed for the user.

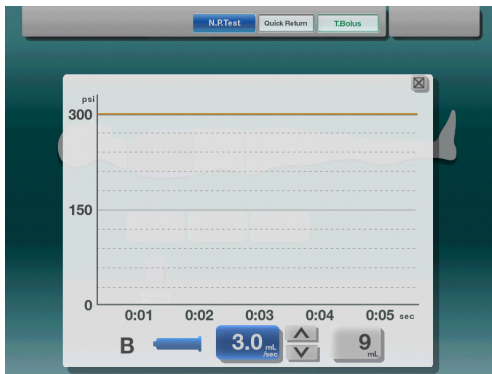

Pressing the N.P.Test key (without an injection first selected) will cause the Needle Placement Test pop-up window to appear. The NPT is available anytime saline is available.

B-side front Powerhead LED will flash rapidly and simultaneously.

The flow rate can be set from 0.1mL/sec to 10mL/sec in 0.1mL/sec increments. The volume range is 1 - 100 or 200mL in 1mL increments.

To initiate the NPT, confirm there is no air in the syringe and tubing then press the Check Air button located on the Powerhead or Console (US Version). The Start OK status should appear.

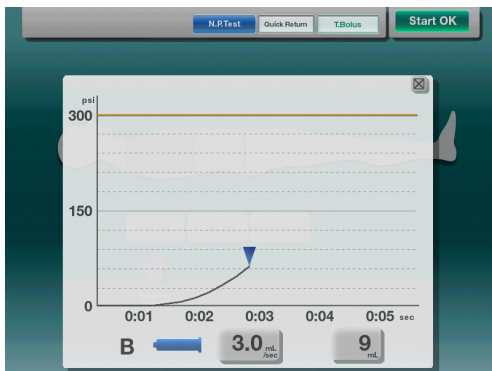

Press a start button on the Powerhead or Remote Switch Box to start the NPT.

The NPT real-time pressure will be displayed during the injection. Press any key to stop the NPT process.

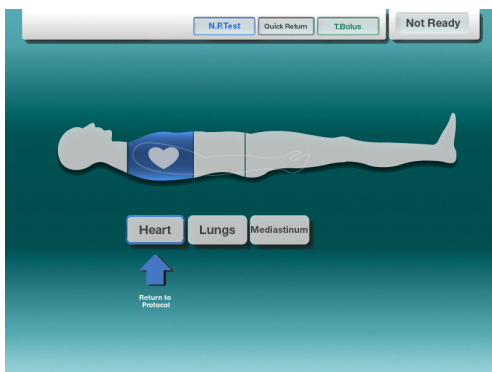

After the N.P.Test is finished or if the window closed and injection protocol was selected beforehand, a "Return to Protocol" message appears under the key previously selected. Press the indicated key to return to protocol.

14. T.Bolus

The T.Bolus function permits quick access and execution of an injection for determining the appropriate scan delay time. To activate, press the T.Bolus key located at the top of the Console display.

The T.Bolus values are automatically set to the values set on the Injector Setup screen for T.Bolus/ N.P.Test. Refer to *page 75 "18.4.T.Bolus / N.P.Test"*.

These parameters will be displayed for the user.

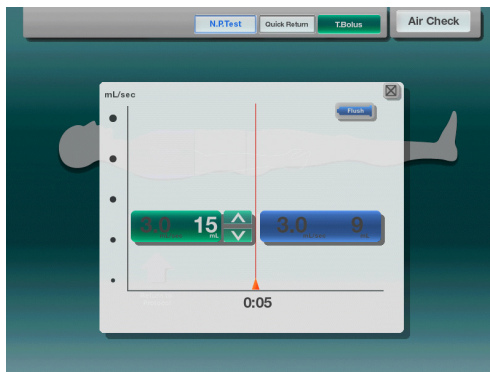

Pressing the T.Bolus key (without an injection first selected) will cause the T.Bolus pop-up window to appear.

NOTE: Pressing the Flush syringe on the T.Bolus pop-up window can be used to turn the flush on and off. The parameters will be maintained.



Press any START on the Powerhead or Switch Box to initiate the T.Bolus injection.

The T.Bolus injection real-time pressure curve will be displayed for reference.

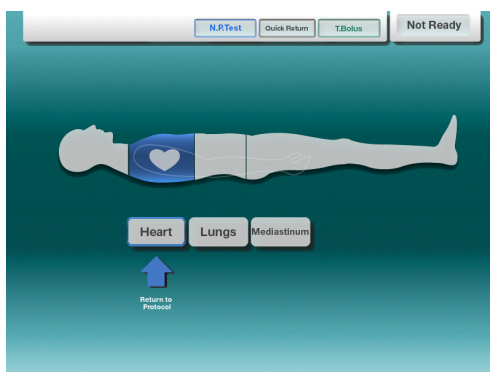

After the T.Bolus is finished or if the window closed and injection protocol was selected beforehand, a "Return to Protocol" message appears under the key previously selected. Press the indicated key to return to protocol.

15. Quick Return

The Quick Return process is stopped after the set volume is filled.

Note: Before filling, remove air contained in the syringe. Otherwise, the total volume in the syringe will be less than the expected volume as it includes the volume of air.

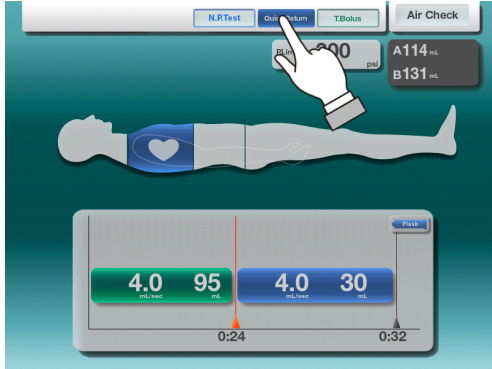

Touch the syringe icon "Quick Return" to access the set-up screen.

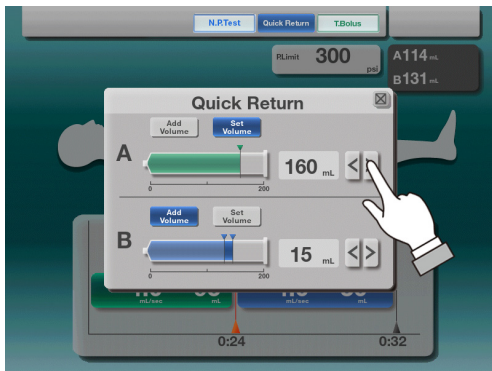



The "Quick Return" set-up screen is shown on the left.

When  is touched, the set value decreases.

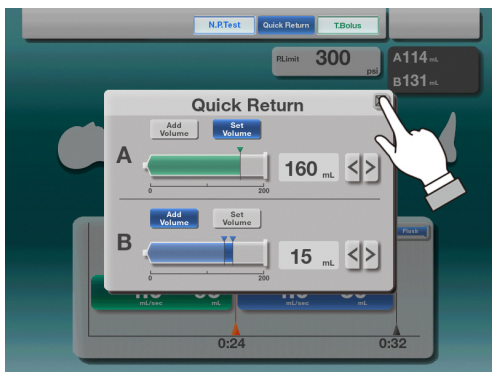
When  is touched, the set value increases.



When  is selected, the amount indicated will be added to the syringe.

When  is selected the syringe is fill to the amount indicated.

Touch  when set-up is complete.

16. Injection Results Screen

The Injection Results Screen enables the user to view previous injection results.

The Protocol Pattern, peak flow rate, volume and pressure are shown. Results are displayed for the last 20 injections in chronological order.

Regardless of Protocol Pattern, injection results are shown for the last 20 injections. Injections older than the last 20 are automatically removed from memory.

IMPORTANT : Pressure graphs are kept in memory even after power is removed.

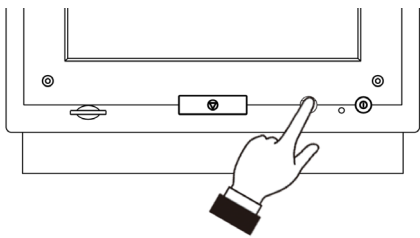

To access HOME screen press the button as shown.

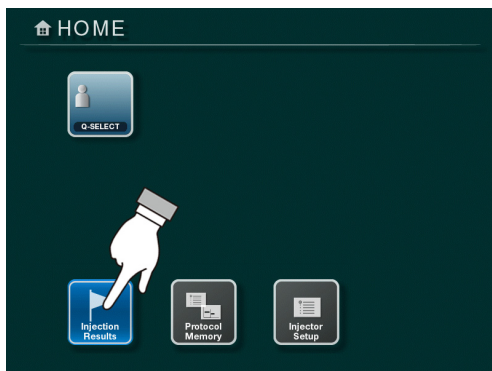

1) Touch the "Injection Results" key.

 A screenshot of the 'Injection Results' screen. It displays a table with 10 rows of data. At the bottom, there is a 'Page Change' key (a circle with the number 1) and a play button icon.

	Date/Time	Protocol Pattern	Flow mL/Rate sec	Volume mL	Pressure psi
1	2012/07/11 AM 11:51	=====	4.0	40	141
2	2012/07/10 AM 11:51	=====	4.0	40	141
3	2012/07/10 AM 11:55	=====	3.0	40	113
4	2012/07/10 AM 11:50	=====	3.0	70	127
5	2012/07/10 AM 11:49	=====	3.0	40	123
6	2012/07/10 AM 11:49	=====	3.0	40	113
7	2012/07/09 AM 11:50	=====	3.0	70	127
8	2012/07/09 AM 11:59	=====	3.0	40	123
9	2012/07/09 AM 11:49	=====	3.0	40	113
10	2012/07/09 AM 11:43	=====	3.0	40	113

2) The latest 10 results will be displayed on the "Injection Results" screen.

To scroll to additional results pages, touch the "Page Change" key (①).

17. Warning and Information Screens

17.1. Blocked Line Warning

During an injection it is possible that a Blocked Line Warning message appears indicating that a Blocked Line condition exists. If this message appears, please check the following:

1. Check the injection line for occlusion, such as a kinked tubing or catheter, or closed stopcock. If an occlusion can not be detected it may be the flow rate is set too high for the pressure limit, try lowering the flow rate or using larger diameter catheter.
2. Please check the pressure limit setting. The pressure limit may be set too low for the programmed flow rate or the catheter bore size may be too small. To maintain the programmed flow rate without activating the pressure limit, use a larger diameter catheter, lower viscosity contrast media or warm the contrast media.

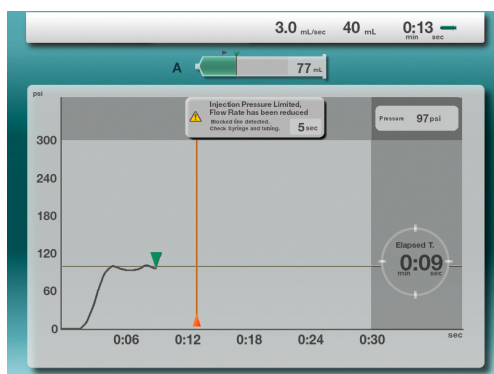

If the injection pressure reaches the pressure limit setting, the pressure limit function will activate and reduce the flow rate until the injection pressure is maintained at the pressure limit setting.

In the event the actual flow rate is reduced to 10% or less of its programmed value, the injector detects the condition as an occluded injection line and displays the message shown on the left, notifying the user of a line blockage.

If the condition continues for a period of 5 seconds, the injection will stop and the **"Blocked Line Detected"** message will appear.

However, during the 5 second period the injection will be resumed automatically if one of the following conditions occurs:

1. Injection pressure reduces below the pressure limit setting.
2. Flow rate increases to more than 10% of its programmed value.

Refer to section "17.1.1.Resuming the injection" if the injection is resumed automatically.

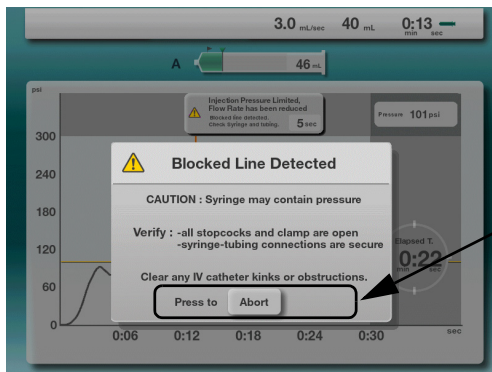

If the injection is stopped due to a blocked line condition the message on the left will be displayed.

Injection will stop and injector rams will reverse slightly to reduce the pressure contained in the syringe. For the safety purpose, key functions will be inoperable for 3 to 5 seconds until the pressure is reduced. After reducing the pressure, the message "Press to Abort" will appear indicating it is safe to continue.

Pressing the "Abort" key will cause the screen to return to the Initial screen, no protocol is selected.

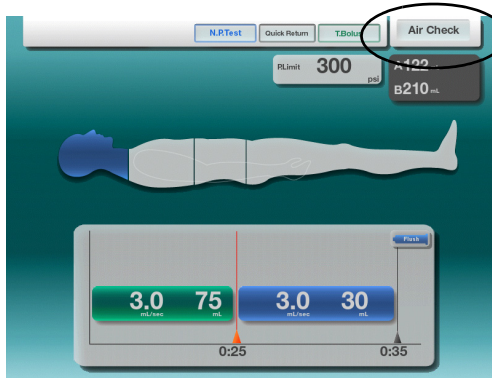

To start the injection again, press the "Air Check" button on the Powerhead after checking the injection line.

Confirm the button is changed from "Air Check" to "Start OK".

Pressing a "Start" key will start the injection again.

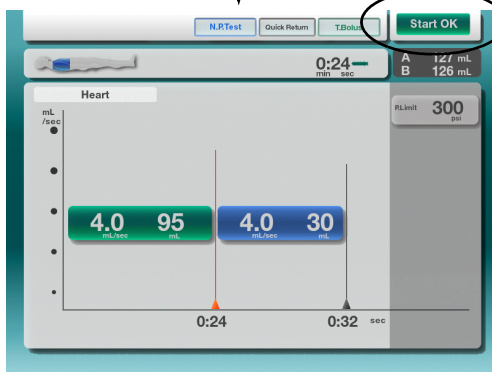

17.1.1. Resuming the injection

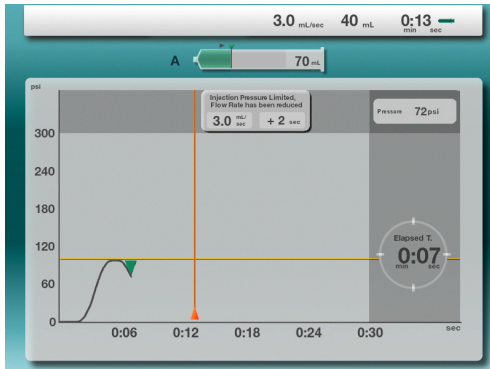

When the injection is completed, the warning message popup will reappear to notify the user the pressure limit was activated during this injection.

17.2. Switch Alarm at power up

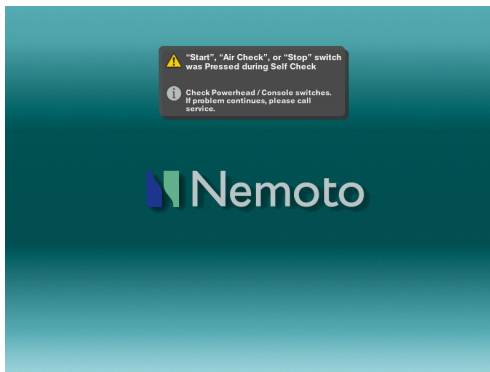

During power up, if any button on the Powerhead, Console, or Switch Box is pressed an alarm message is generated. When the cause of the alarm is corrected, the setup screen will appear without cycling power.

17.3. Warning Screen

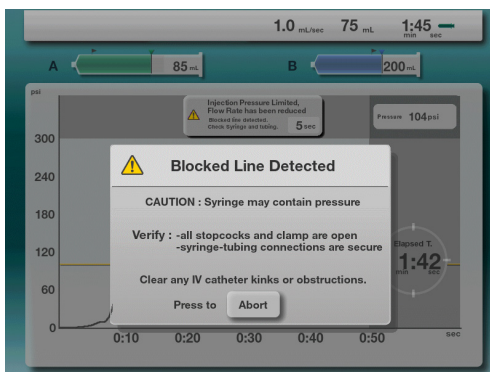

WARNING SCREEN EXAMPLE

When a warning screen is displayed, correct the cause of the warning and touch the "Abort" key.

The setup screen will appear.

17.4. Alarm Screen

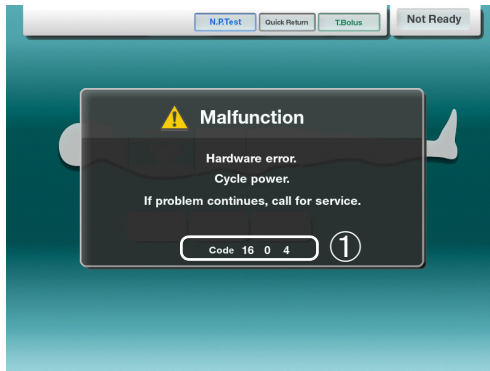

ALARM MESSAGE EXAMPLE, Alarm 1 shown
An Alarm screen will appear when an error is detected. After review of the alarm number (①), turn off the power and remove the alarm cause. Power up the system again to verify the clearing of the alarm condition. If the alarm continues, contact the manufacturer or authorized representative for correction. Refer to the "Troubleshooting" section regarding the causes of alarms.

17.5. Syringe Adapter Warnings

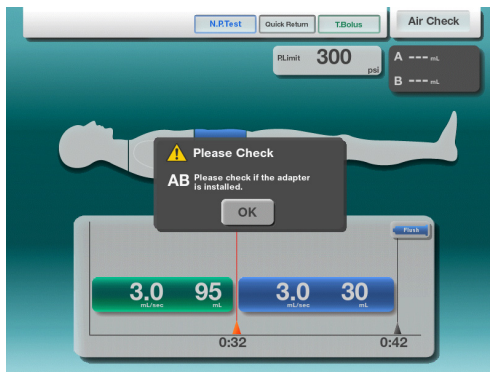

If the Check Air button is pressed and a syringe adapter is not detected or properly installed the message at the left will appear.

If the adapter is installed or corrected the message will automatically disappear.

Pressing OK will override the message but a adapter must be detected before an injection can be executed.

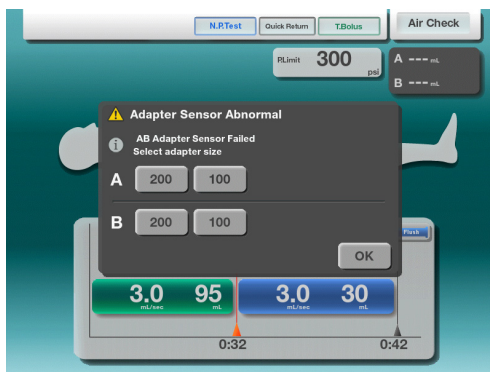

In the event a syringe adapter is not installed or detected, a manual selection window will appear. Depending upon the type of protocol the option for the A-side or both sides will be presented.

Making a manual selection will permit an injection to be executed.

17.6. Pressure Limit Warnings

The DUAL SHOT alpha7 is equipped with redundant pressure protection systems, "primary pressure control" and "secondary pressure control".

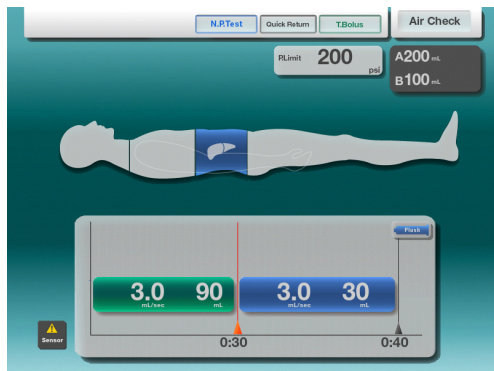

In the event the "primary pressure control" system detects a fault internally to its system, it will automatically switch the pressure protection elements to the "secondary pressure control" system.

If this occurs a pressure icon will appear.

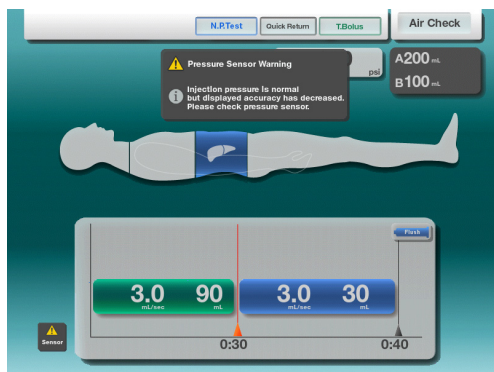

Pressing the icon will cause a message to appear stating the secondary pressure control is activated.

NOTE: When the secondary pressure control is activated, the pressure limit is fixed at maximum pressure limit of each syringe and cannot be changed.

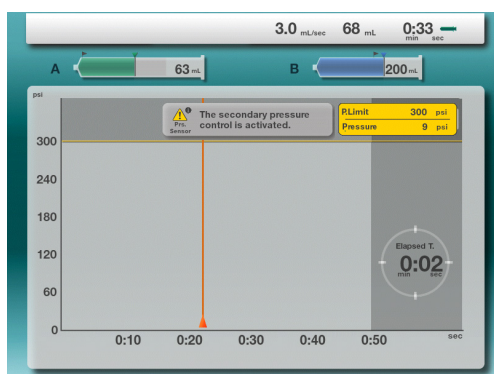

If the secondary pressure control is activated the injection in process screen will operate slightly differently.

The real-time pressure graph will not be displayed during the injection. The actual pressure however will be displayed in real-time below the set pressure limit.

NOTE : When any of these conditions appears, your authorized service provider should be contacted for repair.

18. Injector Setup

The Injector Setup screen is a user accessible function that enables setup and configuration of various parameters.

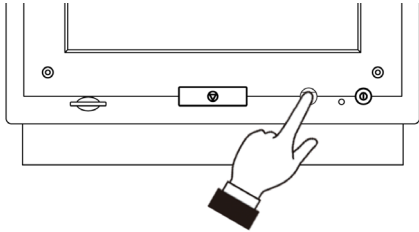

To access the HOME press the button as shown.

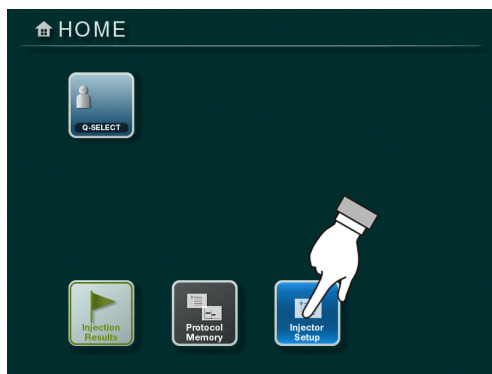

The HOME screen will be displayed.

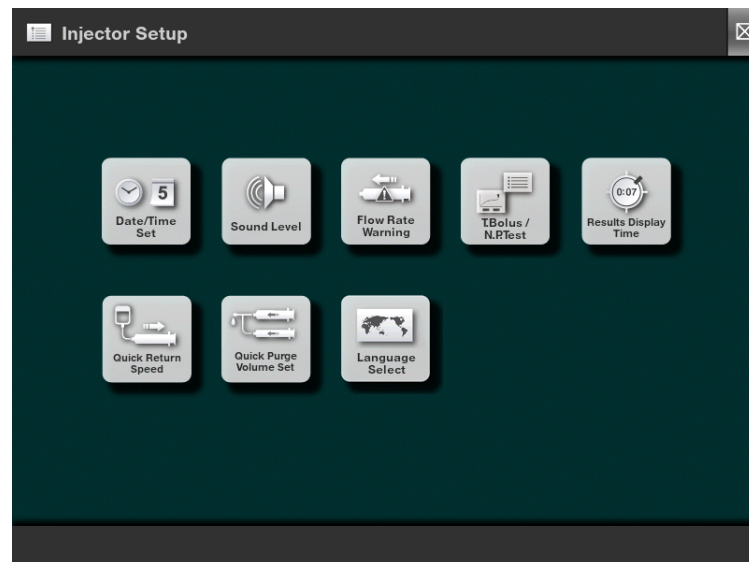

- Press the Injector Setup Key as shown.

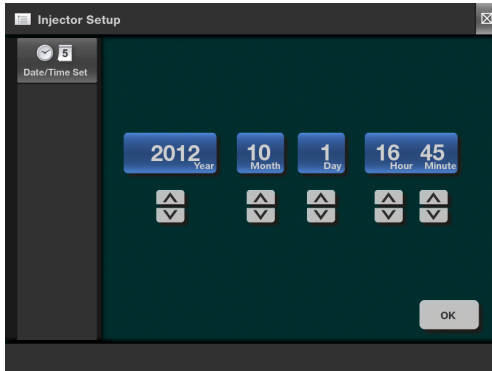

To make adjustments to any of the items listed, press the corresponding key and the setup screens will appear.

18.1. Date / Time Set





To adjust the date and time use the corresponding  and  keys located below each parameter.

After the date and time is set as desired, press the "OK" key to set the new date and time.

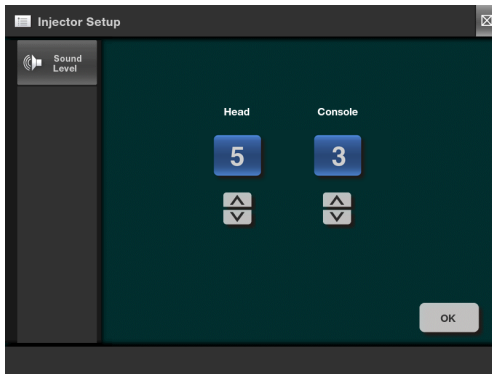
18.2. Sound Level



The sound level for the Console (display) or Powerhead (head) can be set independently. Use the  and  keys to set the desired volume.

The values can be set from 0 (mute) to 15 (maximum).

It is not recommended to mute the sound levels.

Press "OK" when complete.

18.3. Flow Rate Warning

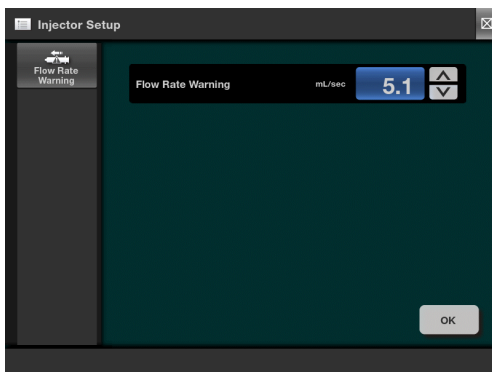

Use the Up/Down arrows to set when the warning message will appear.

Press "OK" when complete.

18.4. T.Bolus / N.P.Test

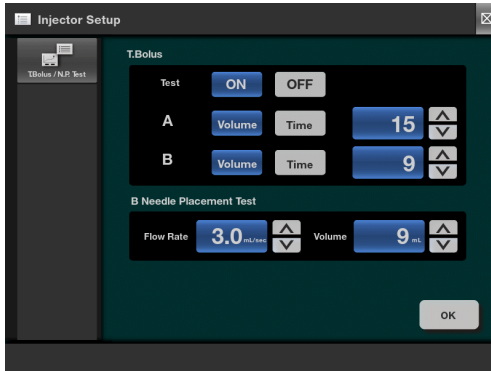

Set default values for T.Bolus and N.P.Test.

Use Up/Down arrows to set the default values for manual entry.

Press "OK" when complete.

18.5. Results Display Time

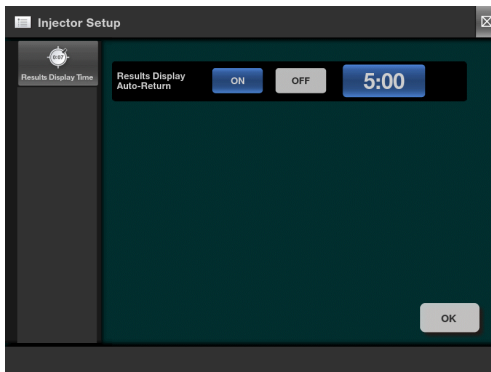

Set if Auto-Return to Main Screen is desired.

Select ON or OFF.

Press "OK" when complete.



EU Version : 0:20

US Version : 5:00

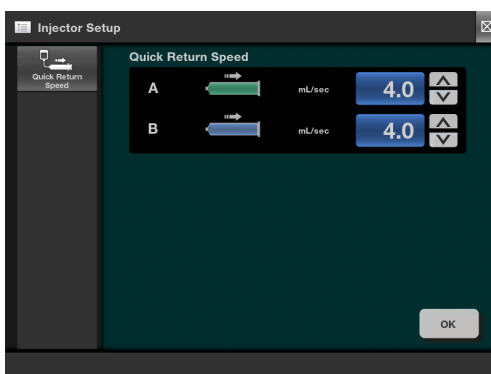
18.6. Quick Return Speed



The Quick Return Speed Set determines the speed that will be used to fill the syringes when using the Quick Return (Auto-Return) sequence.

Use the corresponding  and  keys to set the desired speed.

The slowest speed is 1.5mL/sec and the maximum speed is 8.0mL/sec.

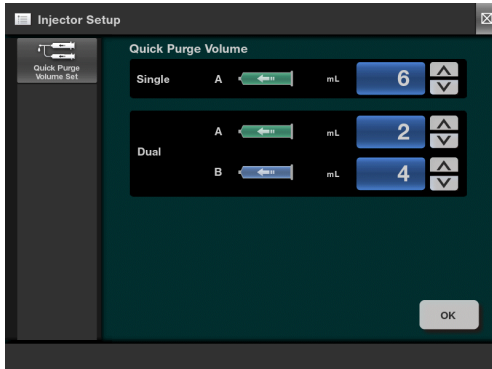

Press "OK" when complete.

18.7. Quick Purge Volume Set



The Quick Purge Volume Set sets the default values for the Quick Purge feature. The Single section sets the default purge volume when only the A-side is being used in the injection protocol.

The Dual section sets the purge volume when both A-side and B-side syringes are installed and required by the injection protocol.

Use the corresponding  and  keys to set the desired volumes. The values programmed when received are based upon the manufacturer's consumables.

18.8. Language Select

The Language Select feature permits changing the user interface language to the user's preferred language.

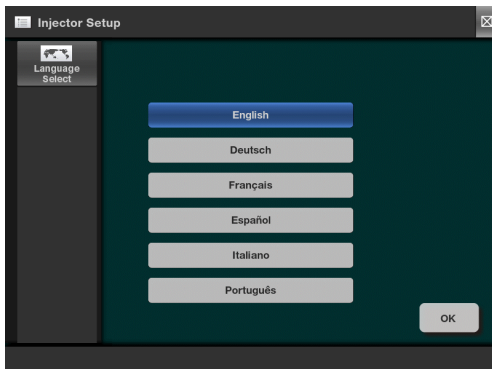

The blue highlighted button identifies the current language setting. To change the language, select the desired language then press the "OK" button.

18.9. Calibration

If a Touch Panel Location Error occurs, calibrate according to the following process.

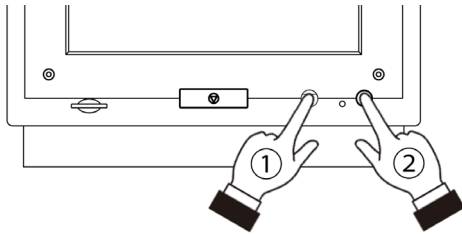

Hold down the HOME button (①) and turn on the console (②) .

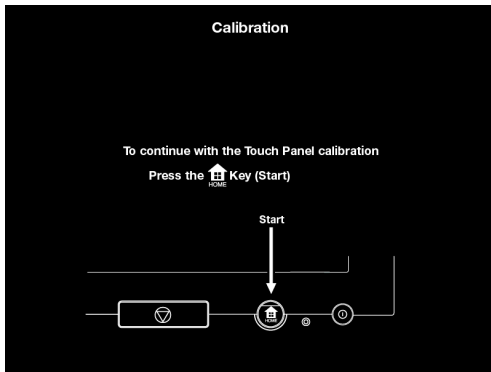

The calibration screen is displayed. Perform the calibration according to the process indicated on the screen.

Press the "HOME" button of the console.

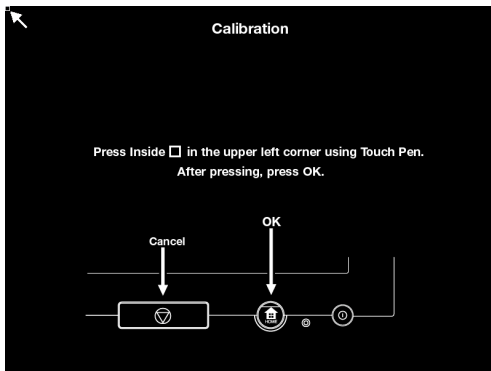

After the following screen is displayed, touch the inside of the red square in the upper left corner with the touch pen.

When the square is selected properly, it will turn green.

If the square does not turn green, try again.

Press the "HOME" button of the console after the square turns green.

Press the "Stop" button of the console to cancel the calibration, and the screen will return to the screen above.

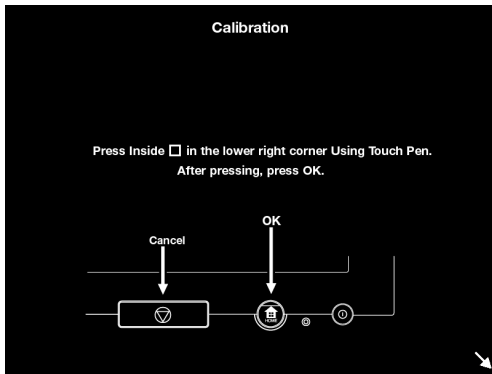

After the following screen is displayed, touch the inside of the red square in the lower right corner with the touch pen.

When the square is selected properly, it will turn green.

If the square does not turn green, try again.

Press the "HOME" button of the console after the square turns green.

Press the "Stop" button of the console to cancel the calibration, and the screen will return to the screen above.

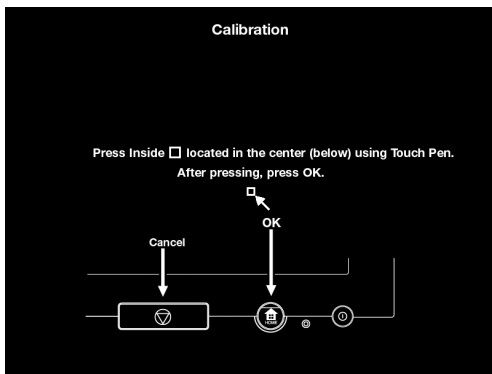

After the following screen is displayed, touch the inside of the red square at the center of the screen with the touch pen.

When the square is selected properly, it will turn green.

If the square does not turn green, try again.

Press the "HOME" button of the console after the square turns green.

Press the "Stop" button of the console to cancel the calibration, and the screen will return to the screen above.

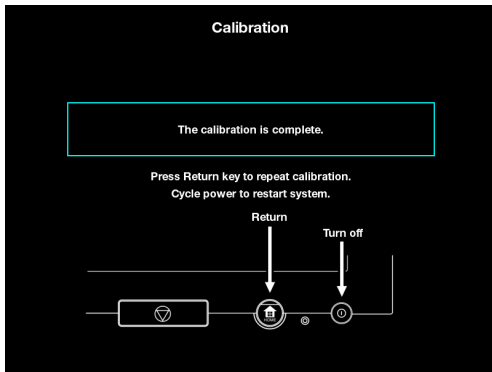

The following screen will be displayed after the calibration is completed.

Turn off the power with the power button pushed and reboot to finish the calibration.

18.9.1. When the calibration is not completed properly

When the calibration is not completed properly, the following screen will be displayed.

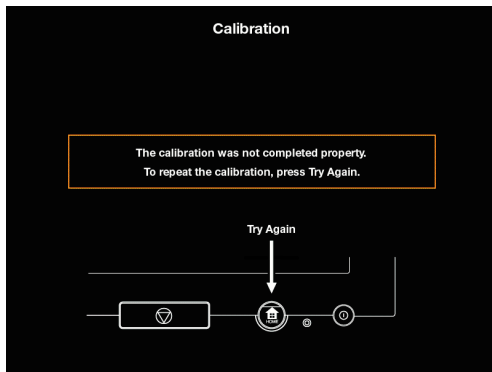

Press the "HOME" button of the console to perform the calibration one more time after the following screen is displayed.



18.10. RTC Check Function (Date/Time Set Check Function)

The clock and calendar of this system are operated by the lithium battery contained in.

A full-charged battery works for about 2 months.

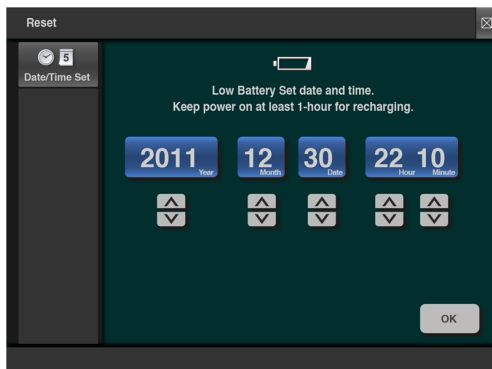
The clock or calendar might get out of order if it does not be operated for long period. In that case, reset the "Date / Time set" screen will appear automatically before operating.



After the "Date/Time Set" screen is displayed, touch the  or  key to set the date and time.

Touch the "OK" key after setting.

The date and time are saved and the power is automatically shut off.

19. Daily and Periodic Inspections

Daily inspections and maintenance are recommended to maintain the function of the DUAL SHOT alpha7 contrast delivery system. The following schedule is recommended:

DAILY: Clean and check each component of the system.

MONTHLY: Clean and check operation of each part of the system.

19.1. Daily Inspection

Always perform the recommended inspections before using the system.

If any malfunction is identified, prohibit use of the system and contact the manufacturer or an authorized representative.

19.2. System Inspection

1. Before use, check movement of the Powerhead rams by moving them completely back and forth at maximum speed, and without a syringe installed.
2. Check that all displays and lamps illuminate.
3. Check that no flaws, wear or tear are found on the connecting cables of the system.
4. Check that cables are properly connected.
5. Check that no unapproved equipment is connected to the system.
6. Visually check the system and the parts for damage.
7. Use of unapproved parts may cause malfunction of the system or harm to the patient. Verify the system is used with only approved devices and consumables.

19.3. Powerhead and Remote Stand Inspection

1. Visually check that no damage such as cracks, are found on the Powerhead cover.
2. Check that the Powerhead and the Powerhead arm rotate freely and the Powerhead rotates more than 180 degrees, but less than 270 degrees in the vertical direction.
3. Check that the casters of the Remote Stand move smoothly and the locking mechanism operate properly.
4. Check the support of the Remote Stand moves up and down smoothly.
5. Check that no damage such as cracks, are found on the Remote Stand. Verify all fasteners are secure.

19.4. Ceiling Suspension Inspection (optional)

1. Visually check for cracks, bends, wear and tear or loose fasteners on ceiling suspension system.
2. Check that the support can be moved up and down lightly without bending.
3. If any defects are identified, prohibit the operation and contact the manufacturer or an authorized representative for correction.

19.5. Cleaning

**Caution**

- To avoid electrical shock, always remove power and disconnect power cable before cleaning the system.
- A main cause of malfunction can be the build up of contrast media on the Powerhead. Cleaning the Powerhead after each use will significantly reduce the likelihood of failure.
- Never use any organic solvents, such as thinners or benzene as they may damage the equipment. Organic solvents are not effective in removing contrast.
- To clean the Powerhead use gauze or paper towel dampened with our recommended disinfectants below. Gently wipe the Powerhead then use a dry cloth to remove any remaining disinfectant.

Recommended Disinfectants

Chlorhexidine gluconate	0.1 - 0.5% solution
Benzalkonium chloride	0.1 - 0.2% solution

- Care should be used when disinfecting the product. The above disinfectants are recommended using only as advised by the manufacturer. Please be certain to follow the manufacturers directions for use, and your healthcare facility procedures for disinfecting and decontamination of product as well as body fluid spills, blood, etc.

19.6. Operation Check

1. Check movement of the Powerhead rams by moving them completely back and forth at maximum speed without a syringe mounted.
2. Move the Powerhead ram forward by pressing the forward key without a syringe mounted, and check that the Powerhead ram stops in 10mL increments automatically with medium and slow buttons.
3. Check that all displays and lamps illuminate.
4. Start an injection using a programmed protocol and check that values of the protocol are displayed on the Console display and that the system operates properly.

20. Planned Maintenance

The injector will continue to perform six years later just as it did when first installed.

The planned maintenance should be performed once annually, and must be performed by a trained and qualified representative of the manufacturer. The items included in the annual preventative maintenance check are:

- Repeat of daily and monthly inspections
- Perform pressure calibration check
 - Re-calibrate if necessary
- Perform system performance checks
- Perform required system upgrades
- Perform safety circuit check

21. Troubleshooting

This system incorporates an automated diagnostic function to ensure a high level of safety in consideration of the various possible malfunctions. When an abnormality occurs, this function activates and displays the description and the Alarm number on the Console display.

This automated diagnostic function will aid in troubleshooting the system's operation and its connections.

In some cases, such as damage of external appearance of the system, abnormal noise and other malfunctions which are unpredictable in nature, the automated diagnostic function may not be effective.

Depending on the malfunction, up to 10mL may be injected before the system can detect and stop the injection.

Pressure limit warning is indicated during an injection	
Problem	Pressure limit is activated. The flow rate is decreased from programmed flow rate.
Cause	The pressure limit setting is too low for the programmed flow rate. The injection line (needle, tube, catheter, etc.) is too small or obstructed.
Low pressure warning is displayed during an injection	
Problem	No pressure is detected
Cause	The syringe does not contain contrast or saline. Syringe may not be installed.
Check Point	Check the syringe or injection check

Remove power if any of the following alarms are displayed.

Alarm 2	
Problem	Over Volume
Cause	Internal error or using unapproved consumables. If the alarm continues, contact your service representative.
Alarm 3	
Problem	Abnormal Injection Flow Rate
Cause	More than 25% error tolerance of the preset flow rate value has occurred. If alarm continues, contact your service representative.
Alarm 6	
Problem	Abnormal Motor Stopping
Cause	Internal failure. If alarm continues, contact your service representative.
Alarm 7	
Problem	Hardware Trouble
Cause	This error will appear when trouble is detected with hardware for example, motor, memory, etc.
Alarm 11	
Problem	Encoder Trouble
Cause	Internal failure. If alarm continues, contact your service representative.
Alarm 13	
Problem	Trouble with Limit Sensor
Cause	Both forward and reverse limits activated at the same time. If alarm continues, contact your service representative.
Alarm 14	
Problem	Trouble with Powerhead
Cause	Improper rotation of the motor. If alarm continues, contact your service representative.
Alarm 16	
Problem	Communication Error
Cause	This error will appear if the communications between the Console and Powerhead is not operating correctly.
Alarm 18	
Problem	Slit-Pulse Error
Cause	This error will appear when the Slit Pulse counter does not change after there is a 5mL increase or decrease in the remaining volume.

Alarm 20	
Problem	Unacceptable Protocol
Cause	This error will appear when the protocol parameters are not within valid ranges or if different between Powerhead and Console.
Alarm 30	
Problem	Invalid Device Type
Cause	This error will appear if the Console and Powerhead versions are not compatible with each other.
Alarm 50	
Problem	Power-Supply Undefined
Cause	This error will appear, if during the power-on checks, the Console and Powerhead cannot establish a connection with each other.

22. Guidance and manufacturers declaration

The following functions of the DUAL SHOT alpha7 are deemed as Essential Performance and were tested for electromagnetic compatibility in compliance with IEC60601-1-2:2007.

Essential Performance:

Inject the liquid contained in the Syringe mounted on the device with controlling the flow rate and the volume.

Guidance and manufacturer's declaration - electromagnetic emissions		
The DUAL SHOT alpha7 is intended for use in the electromagnetic environment specified below. The customer or the user of the DUAL SHOT alpha7 should assure that it is used in such an environment.		
Emissions test	Compliance	Electromagnetic environment - guidance
RF emissions EN 55011 CISPR 11	Group 1	The DUAL SHOT alpha7 uses RF energy only for its internal function. Therefore, its RF emissions are very low and is not likely to cause any interference in nearby electronic equipment.
RF emissions EN55011 CISPR 11	Class A	The DUAL SHOT alpha7 is suitable for use in all establishments other than domestic and those directly connected to the public low-voltage power supply network that supplies buildings used for domestic purposes.
Harmonic emissions EN 61000-3-2 IEC 61000-3-2	Not applicable	
Voltage fluctuations / flicker emissions EN 61000-3-3 IEC 61000-3-3	Not applicable	

Guidance and manufacturer's declaration - electromagnetic immunity			
The DUAL SHOT alpha7 is intended for use in the electromagnetic environment specified below. The customer or the user of the DUAL SHOT alpha7 should assure that it is used in such an environment.			
Immunity test	EN 60601 / IEC60601 test level	Compliance level	Electromagnetic environment - guidance
Electrostatic discharge (ESD) EN 61000-4-2 IEC 61000-4-2	\pm (2, 4, 6) kV contact \pm (2, 4, 8) kV air	\pm (2, 4, 6) kV contact \pm (2, 4, 8) kV air	Floors should be wood, concrete or ceramic tile. If floors are covered with synthetic material, the relative humidity should be at least 30 %.
Electrical fast transient/burst EN 61000-4-4 IEC 61000-4-4	\pm 2 kV for power supply lines \pm 1 kV for input/output lines	\pm 2 kV for power supply lines \pm 1 kV for input/output lines	Mains power quality should be that of a typical commercial or hospital environment.
Surge EN 61000-4-5 IEC 61000-4-5	\pm 1 kV differential mode \pm 2 kV common mode	\pm 1 kV differential mode \pm 2 kV common mode	Mains power quality should be that of a typical commercial or hospital environment.
Voltage dips, short interruptions and voltage variations on power supply input lines EN 61000-4-11 IEC 61000-4-11	< 5 % UT (> 95 % dip in UT) for 0,5 cycle 40 % UT (60 % dip in UT) for 5 cycles 70 % UT (30 % dip in UT) for 25 cycles < 5 % UT (> 95 % dip in UT) for 5 sec	5 % UT (> 95 % dip in UT) for 0,5 cycle 40 % UT (60 % dip in UT) for 5 cycles 70 % UT (30 % dip in UT) for 25 cycles < 5 % UT (> 95 % dip in UT) for 5 sec	Mains power quality should be that of a typical commercial or hospital environment. If the user of the DUAL SHOT alpha7 requires continued operation during power mains interruptions, it is recommended that the DUAL SHOT alpha7 be powered from an uninterruptible power supply or a battery.
Power frequency (50/60 Hz) magnetic field EN 61000-4-8 IEC 61000-4-8	3 A/m	3 A/m	Power frequency magnetic fields should be at levels characteristic of a typical location in a typical commercial or hospital environment.
NOTE UT is the a.c. mains voltage prior to application of the test level.			

Guidance and manufacturer's declaration - electromagnetic immunity

The DUAL SHOT alpha7 is intended for use in the electromagnetic environment specified below. The customer or the user of the DUAL SHOT alpha7 should assure that it is used in such an environment.

Immunity test	EN 60601 / IEC60601 test level	Compliance level	Electromagnetic environment - guidance
Conducted RF EN61000-4-6 IEC61000-4-6	3 Vrms 150 kHz to 80 MHz	3 Vrms 150 kHz to 80 MHz	<p>Portable and mobile RF communications equipment should be used no closer to any part of the DUAL SHOT alpha7 including cables, than the recommended separation distance calculated from the equation applicable to the frequency of the transmitter.</p> <p>Recommended separation distance</p> $d = 1,2\sqrt{P}$
Radiated RF EN61000-4-3 IEC61000-4-3	3 V/m 80 MHz to 2,5 GHz	3 V/m 80 MHz to 2,5 GHz	

NOTE 1 : At 80 MHz and 800 MHz, the higher frequency range applies.

NOTE 2 : These guidelines may not apply in all situations. Electromagnetic propagation is affected by absorption and reflection from structures, objects and people.

a Field strengths from fixed transmitters, such as base stations for radio (cellular/cordless) telephones and land mobile radios, amateur radio, AM and FM radio broadcast and TV broadcast cannot be predicted theoretically with accuracy. To assess the electromagnetic environment due to fixed RF transmitters, an electromagnetic site survey should be considered. If the measured field strength in the location in which the DUAL SHOT alpha7 is used exceeds the applicable RF compliance level above, the DUAL SHOT alpha7 should be observed to verify normal operation. If abnormal performance is observed, additional measures may be necessary, such as reorienting or relocating the DUAL SHOT alpha7.

b Over the frequency range 150 kHz to 80 MHz, field strengths should be less than 3 V/m.

Recommended separation distances between portable and mobile RF communications equipment and the DUAL SHOT alpha7

The DUAL SHOT alpha7 is intended for use in an electromagnetic environment in which radiated RF disturbances are controlled. The customer or the user of the DUAL SHOT alpha7 can help prevent electromagnetic interference by maintaining a minimum distance between portable and mobile RF communications equipment (transmitters) and the DUAL SHOT alpha7 as recommended below, according to the maximum output power of the communications equipment.

Rated maximum output power of transmitter W	Separation distance according to frequency of transmitter m		
	150 kHz to 80 MHz $d = 1,2\sqrt{P}$	80 MHz to 2,5 GHz $d = 1,2\sqrt{P}$	800 MHz to 2,5 GHz $d = 2,3\sqrt{P}$
0,01	0,12	0,12	0,23
0,1	0,38	0,38	0,73
1	1,2	1,2	2,3
10	3,8	3,8	7,3
100	12	12	23

For transmitters rated at a maximum output power not listed above, the recommended separation distance d in meters (m) can be estimated using the equation applicable to the frequency of the transmitter, where P is the maximum output power rating of the transmitter in watts (W) according to the transmitter manufacturer.

NOTE 1 At 80 MHz and 800 MHz, the separation distance for the higher frequency range applies.

NOTE 2 These guidelines may not apply in all situations. Electromagnetic propagation is affected by absorption and reflection from structures, objects and people.

Maximum Cable Length Information

Following table shows the maximum length for our specified cables.

Do not use the cable other than those specified in the below table.

It may result in increased emission or decrease immunity with the Electromagnetic Compatibility of the system.

No.	Cable	Maximum length	Shield
HC-005	Powerhead extension cable	15m	Shielded
HC-006		20m	
AC-002	Power Cable (CE)	2.5m	-
AC-003	Power Cable (FDA)	5m	-
AC-004	Power Cable (SDA)	2.5m	-

23. Contact Information

If there are any questions or concerns relating to this information please consult the Operation Manual or the Service and Parts Manual. Please feel free also to contact the manufacturer or any of its authorized representatives:

Manufacturer

Nemoto Kyorindo Co., Ltd.
2-27-20 Hongo, Bunkyo-ku
Tokyo 113-0033 Japan

Telephone: +81-3-5842-8571

FAX:+81-3-5842-8589

Authorized Representative (EU)

Medicor International NV
Timmerik 2
3020, Herent
Belgium

Telephone: +32 16 27 18 18

E-mail: info@medicor-international.com



