

LIGHTING CONTROL SYSTEM

Throughout the warranty period (10 years), the client will not incur additional charges for the operation of the control system and user access to the software. The system supplier or contractor shall provide the user with free access to the full functionality of the control system. In order to ensure full functionality of the control system, the contractor is responsible for providing power 24H/7 on the circuits where luminaires with the control system will be used.

The offered control system meets all the requirements / points of the control system specification according to the document "anexa_2_-_specificatii_tehnice.pdf" published under the tender procedure "Finalizarea sistemului de iluminat public stradal pe tot teritoriul municipiului Cahul - REPETAT".

1. System security

1. The CMS software shall use communication security protocols such as TLS 1.1. or equivalent.
2. the system allows firmware updates via radio (OTA) on 100% of the lighting controllers in the project area.
3. The platform allows users to be created, edited and deleted and assigned to existing profiles on behalf of the client. Users can be assigned roles and different levels of authorisation can be defined within the system.
4. New users will be created via an email invitation with an active link that the new user should click to set their own password. This will avoid the need for the administrator to send the first password.
5. The CMS software will allow login with 2 levels of user authorisation.

2. Luminaire controller

1. The manufacturer shall offer controllers in ZHAGA connector versions.
2. Create local mesh networks and communicate with the system servers (cloud) via access gateways operating at least in 2G and 4G communication bands.
3. Complies with current electrical directives, in particular the RED directive.
4. Can control up to 4 Dali controllers.
5. Monitors the on and off times of luminaires and energy consumption.
6. It has a protection level of at least IP66 and IK08.
7. It communicates information on the value of electrical parameters (at least: voltage, power, power factor and light source operating time).
8. The controllers shall be able to detect and report the following events:
 - a. A non-functioning LED panel.
 - b. DALI controller error.
 - c. Loss of power.
 - d. Exceeding the defined electrical parameter values.
9. Each Luminaire Controller is equipped with an ambient light sensor which can modify the lighting schedule of the luminaires depending on the ambient light levels. The sensor tripping levels are definable from within the CMS. It will be possible to modify the start and end times of lighting by introducing a delay with respect to sunrise and/or sunset.
10. The Luminaire Controller enables:
 - a. Local storage of dimming/lighting profiles (schedules), with multiple points to modify light levels

- b. Work autonomously, without communication with the system, carrying out the lighting according to the stored profiles (schedules)
 - c. Determining which of the multiple stored profiles (schedules) is valid based on the calendar and priorities of the profiles (schedules)
 - d. Realise lighting based on external sensors (light sensor, motion sensor).
11. The controllers send monitored data no less frequently than every 1 hour, with the frequency of sending data being configurable. In addition, when the luminaire controller detects an alarm, it sends it immediately.

3. Wireless network

1. The luminaire controllers automatically connect to the system after installation and automatically establish data paths with the server on which the CMS software runs. Registration will occur automatically, after scanning the driver's unique code using a dedicated mobile app. Luminaire drivers will not need to be assigned to specific gateways/access points by the installer. The installation process is fully secure and automatic.
2. The addition of new light points does not require any alterations to the existing installation (e.g. running additional cables, connecting circuits, etc.).
3. Communication between the luminaire controllers and the collection points of the system takes place in accordance with EN 300 328, with the speed of the information exchange enabling the system to be extended to include tracking lighting.

4. Central management software (CMS)

1. The user interface is web-based and accessible via a standard web browser on Windows PCs, MACs and Android and iOS tablets.
2. Allows user profiles to be set up and the rights levels of selected users to be managed.
3. Allows objects of the luminaire type to be defined, either by manual addition, CSV import or via API.
4. It is able to manage groups and organise luminaires with additional attributes (such as street name, premise number, ID, colour, membership of lighting cabinet, circuit, etc.).
5. Allows authorised users to create device groups (e.g. based on electrical network information, geographical location, sensor allocation, device type).
6. Allows users to search for one or more luminaires, Luminaire Controllers, cabinets or other objects based on their attributes, address, geographical group, name, identifier or any other attribute.
7. It can store many descriptive attributes of a luminaire (or any other type of object), including its address, GPS position, wattage, luminaire model, driver serial number, luminaire driver firmware version (sent from the luminaire driver) or warranty end date.
8. Allows authorised end-users to add their own descriptive attributes.
9. It has a graphical interface in the form of a website with a map on which all the points belonging to the system are represented by icons.
10. The CMS allows end users to create, select, edit and move objects on maps.
11. Allows you to graphically select several luminaires (or any other type of object) to create lists, edit their attributes, assign them a control program or execute a manual command.
12. Displays data in 24-hour format and local time.
13. Automatically takes into account summer and winter time without user intervention.
14. Collects all alarms and notifications and their returns sent by the controllers.
15. Enable the generation of analytical reports from collected data and inventory data. The CMS software will, for example, produce reports such as:

- a) A list of luminaires with which the Controller has not communicated for more than 24 hours, ordered in descending order, first the one that has not communicated the longest.
 - b) A list of luminaires in a given geographical group that have experienced lamp failure in the last 15 days, with their address classified by street, luminaire model and duration of lamp failure (in working and calendar days).
16. Exports reports as a PDF file.
 17. Allows the scheduling of reports and automatically sends the generated result by e-mail to a list of selected users of the CMS software.
 18. Based on the cumulative energy consumption data (kWh) collected from each Luminaire Controller, the CMS Software will provide an energy consumption report for each geographical group selected by the user.
 19. The schedule definition allows for a minimum of 7 independently definable time intervals with freely definable luminaire illumination/darkening levels and duration of the interval. In addition, it allows/provides:
 - a) Resolution of setting cut-off points for time intervals of no more than 5 minutes,(allows setting a time of e.g. 22:35).
 - b) Dawn and dusk schedules based on an astronomical clock
 20. Allows the prioritisation of individual schedules.
 21. In the case of lighting circuits controlled by astronomical clocks from a lighting cabinet not connected to the CMS, the system provides the possibility of disabling alerts from controllers fed from such a cabinet in order to eliminate false alarms.
 22. The CMS software allows authorised end users to send real-time on, off and dimming commands to a Luminaire Controller or group of Luminaire Controllers.
 23. The CMS software supports dynamic lighting systems to configure which sensor acts on which Luminaire Controller.
 24. The CMS software allows the user to easily view sensor data throughout the day (number of triggers).
 25. The CMS software provides RESTful APIs, or equivalent, to enable integration with external systems.
5. **Installation and commissioning**
1. luminaire controllers can be installed on any type of luminaire from any manufacturer, provided they are equipped with a suitable ZHAGA-compliant socket so that inventory information can either be automatically uploaded or entered into the CMS via a .csv file and managed there. A detailed and precise procedure for the provision of inventory information is provided when necessary. The luminaire controllers will automatically read the power consumed by the luminaire and compare its alarm thresholds and other parameters to automatically trigger alarms.

The heart of SMART City

The **Urban** Smart City system monitors and manages infrastructure lighting and connected sensors forming a neural network of the city. It is a basis for the further development of intelligent functions, which will be provided as part of one Smart City platform.

MEET URBAN



- Cloud management system.
- Central and mobile Urban application.
- External devices: gateways, controllers installed inside or outside of the luminaires.

Cloud application

- Installed on a cloud server.
- Available 24 hours a day, 365 days a year from via a web browser or as a dedicated application for mobile devices.
- Provides access via a web interface without installing dedicated software.
- Collects and stores statistics, configurations and event logs from managed devices.
- Automatically manages HUB and controller software updates in a way that requires no action from the user.
- Implemented security mechanisms triggered in the event of unauthorized access and theft of SIM cards.
- Includes full communication encryption.

Hardware requirements

The **desktop application** requires a stable internet connection and a desktop or laptop computer meeting the following specification:

- Intel® i5 @ 1.6 Ghz processor or higher
- 8GB RAM or more
- Intel® UHD 620 or newer graphics card
- Windows 10
- Firefox or Chrome browser

The **mobile application** requires a stable internet connection and a smartphone or tablet running one of the following operating systems:

 **iOS:** version 9.0+

 **Android:** version 7.x+

Learn more about our SMART offer:



System description

The **Urban** management system is installed on cloud servers accessible via a web browser. It manages the work of the entire BIOTcloud environment. Communicates, collects and analyzes data from controllers. Takes actions based on implemented algorithms. The management system is also responsible for software updates and configuration of field-installed devices.

- Two-step user authentication.
- Configurable user settings.
- Administrator function with user management (creating, modifying and deleting accounts, assigning roles and permissions to users).
- Dashboard with the most important information.
- Map presentation with street and building plans, lighting network diagram, icons illustrating the installation points on the map.

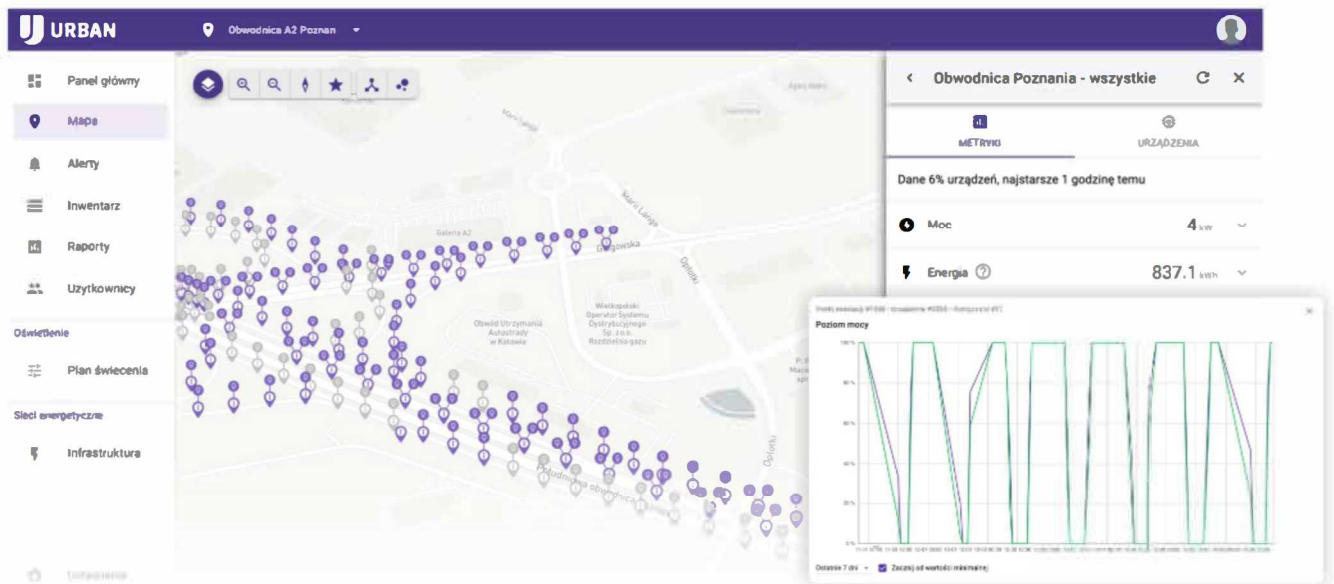

Design and installation

- Lighting points registration,
- Infrastructure database maintenance,
- Lighting plans creation,
- Support during luminaire assembly,
- Precise placement on the map,
- Creating, deleting and editing installation points (POIs).

Management

- Behavior rules and patterns creations,
- Data aggregation and analytics,
- Remote management and control,
- Automatic reporting.

Maintenance

- Energy consumption reports,
- Technical condition and luminaire status reports,
- Remote management: dimming or luminaire ON/OFF,
- Automatic system notifications,
- Events and warnings reports via SMS and e-mail,
- Quality and connection pattern indication,
- Existing lighting plans modification,
- Creating and managing groups of luminaires.

The **Urban** Smart City system monitors and manages infrastructure lighting with connected sensors in a MESH network (THREAD protocol).

The main advantages of using the MESH topology network:

- automatic network reconfiguration in case of disturbances and damages of individual devices,
- possible use of advanced scenarios (e.g. follow-up light),
- no need to install a separate SIM card in each device.

eBLOC-Z CONTROLLER

Group in catalogue: SMART

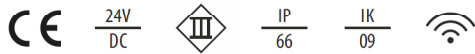

The eBLOC-Z lighting controller has been created to facilitate the remote control of street lighting. Connected to a Zhaga socket - it allows the user to control lighting with the DALI or 1...10V power supply and to manage other components of luminaires (e.g. NTC thermistors). Wireless communication enabled by eBLOC-Z means, that the user can send commands and configurations, as well as receive alerts pertaining to events and current parameter values. The eBLOC-Z is used as a controller with LUG luminaires but it can also be sold as a separate product for assembly in luminaires from other manufacturers.

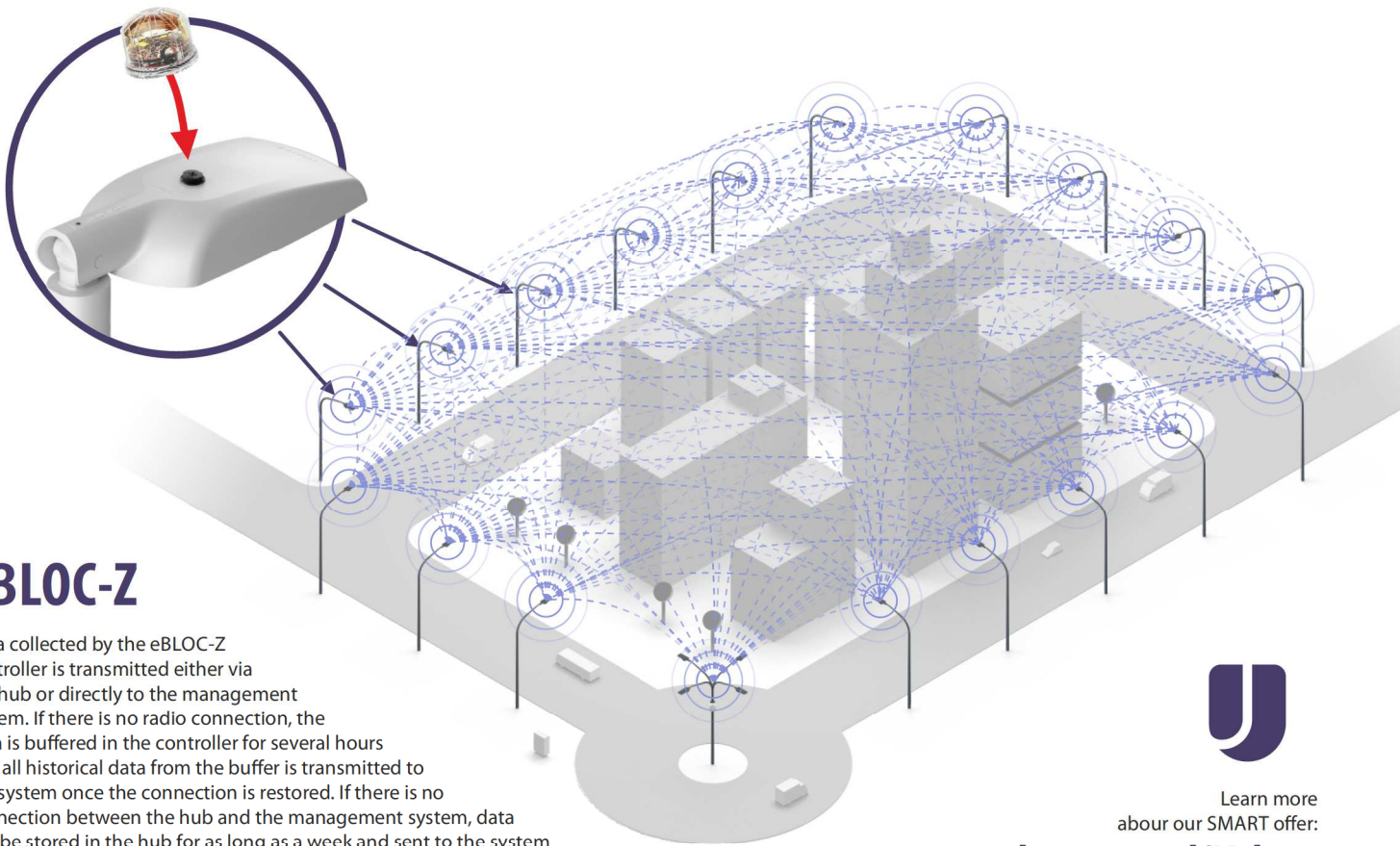

eBLOC-Z

Data collected by the eBLOC-Z controller is transmitted either via the hub or directly to the management system. If there is no radio connection, the data is buffered in the controller for several hours and all historical data from the buffer is transmitted to the system once the connection is restored. If there is no connection between the hub and the management system, data can be stored in the hub for as long as a week and sent to the system once the connection is restored.



Learn more
about our SMART offer:

www.lug.com.pl/Urban

GENERAL DATA

- 2.4 GHz radio controller with Thread or LTE Cat M1/2G communication with a built-in antenna
- System connection via 4-pin Zhaga socket
- Power control via DALI interface or 1...10V programmable output
- Logical system sensor input
- Built-in NTC temperature sensor and dusk sensor
- Built-in GNSS receiver (in some versions)
- Built-in twilight sensor
- Real-time clock which continues operation in the case of power loss
- Dedicated to the BIOTcloud lighting control system
- Lifetime of up to 100 000 h

eBLOC-Z CONTROLLER

Group in catalogue: SMART

AVAILABLE VERSIONS

Code	Mounting	Power	Type of equipment	Dimensions [mm] L H
770030.001	outside	24 V DC	Thread communication	80 59
770030.002	outside	24 V DC	Thread communication + GNSS localization	80 59
770030.003	outside	24 V DC	LTE Cat M1/2G communication + GNSS localization	80 59
770030.004	outside	24 V DC	LTE Cat M1/2G communication + GNSS localization	80 59

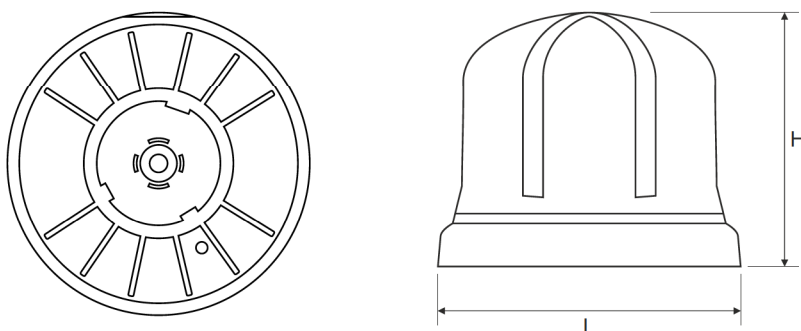
DIMENSIONS**ADDITIONAL PHOTOS**

eBLOC-Z CONTROLLER

Group in catalogue: SMART

ELECTRICAL PARAMETERS OF THE MODULE

TECHNOLOGICAL PROPERTIES OF THE ELECTRICAL MODULE

POWER SUPPLY	Supply voltage [U_i]: 15...24 V DC Input power [P_i]: 0,5 W
INPUT/OUTPUT PARAMETERS	Max. no. of controlled DALI devices [n]: 5 Max. 1...10V output load current [I]: 10 mA Max. input voltage of Sensor Input line [$U_{\text{SensIn(MAX)}}$]: 24 V Min. input voltage of Sensor Input line in high state [$U_{\text{SensIn(Hmin)}}$]: 10 V Max. input voltage of Sensor Input line in low state [$U_{\text{SensIn(Lmax)}}$]: 4 V
ENVIRONMENTAL PARAMETERS	Ambient temperature [T_{amb}]: -40 ... +70°C Storage temperature [T_{stor}]: -30 ... +85°C Relative humidity [h]: 10 ... 90% Degree of water and dust protection: IP66 Impact resistance: IK09
OTHER	Radio frequency protocol: IEEE 802.15.4, 6LoWPAN, Thread Frequency band: 2,4 GHz

Net weight: **150 g**Lifetime ($T_a = 70^\circ\text{C}$): **100 000 h**Application: **for outdoor luminaires**

DESCRIPTION OF MODULE CONNECTORS

1	24V Power	Power input
2	-DALI/-1...10 V Sensor GND Power GND	Negative output DALI and DIM 1...10 V, GND for 24V power and Sensor Input
3	+DALI/+1...10 V	Positive output DALI and DIM 1...10 V
4	Sensor Input	External sensor input

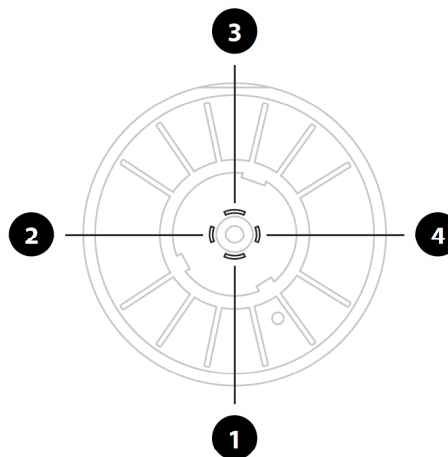



HUBloT-3 is a wireless border router (also known as a gateway) that has an Internet connection (through a cell phone network or LAN). Its role is to ensure communication between BIOTcloud system servers and the end devices (radio mesh nodes) such as iBLOC, eBLOC-N or eBLOC-Z lighting controllers. HUBloT-3 has ten on/off control inputs, as well as an RS-485 interface for connecting external devices. For example, you can connect to this interface the iNET-3P power/energy meter that is normally used for monitoring 3-phase AC lines. HUBloT-3 has four relay outputs that can be used to control various external devices installed in a switchboard cabinet.



HUBloT-3 serves as a bridge connecting the management system installed in a cloud with controllers and sensors located at various sites. Communication between the hub and the management system takes place through the MQTT protocol and SSL certificates. The 802.15.4.6 LoWPAN and Thread protocol with extensions dedicated to Smart City are used for the purpose.

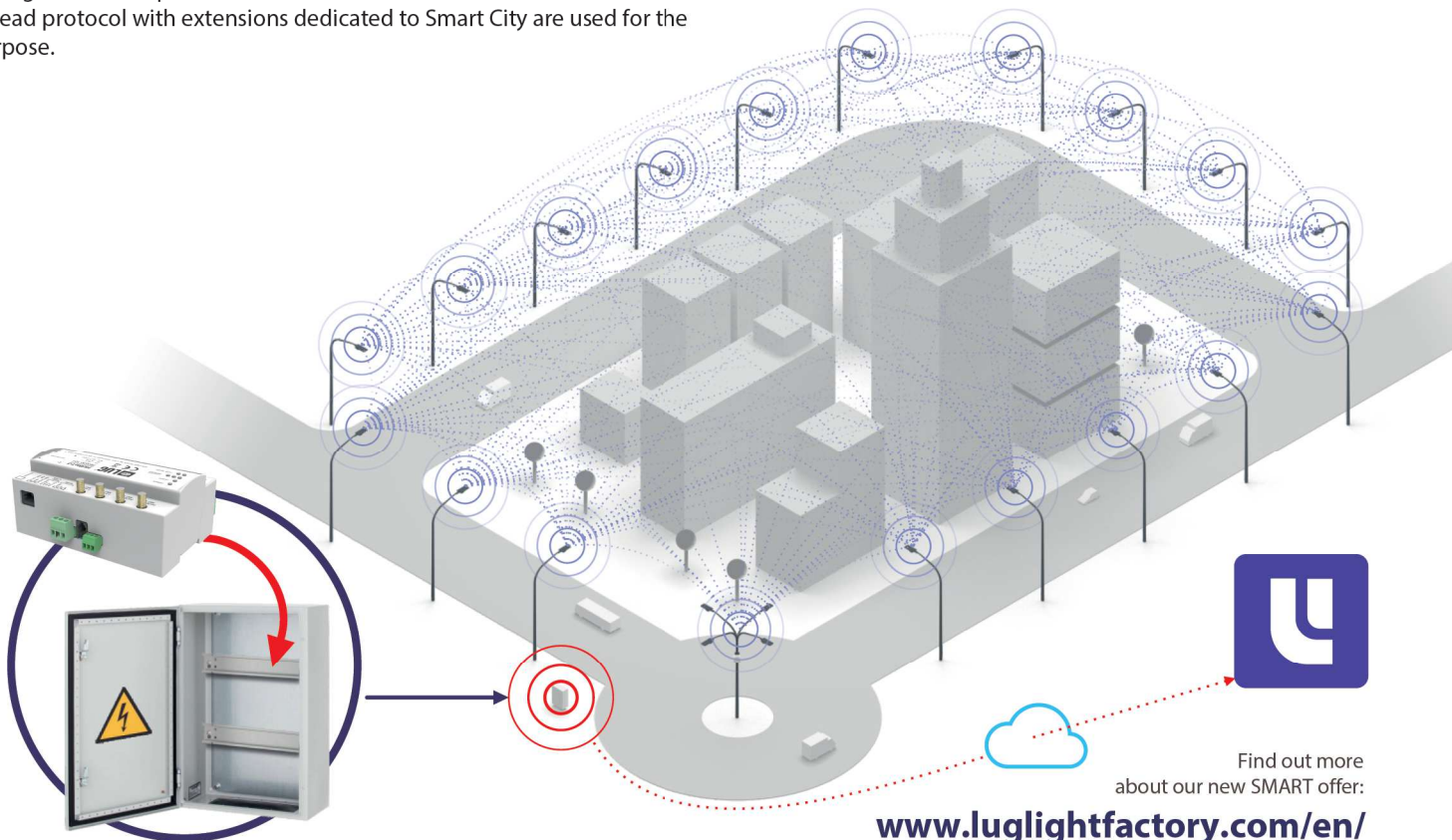

Find out more
about our new SMART offer:
[www.luglightfactory.com/en/
products/controls-and-sensors](http://www.luglightfactory.com/en/products/controls-and-sensors)

GENERAL DATA

- 2G/3G/4G radio module with two antenna sockets
- Two 2.4 GHz radio modules for THREAD communication (radio mesh)
- Ethernet 10/100Base-T port
- RS-485 port
- Ten control inputs
- Four relay outputs

- Assembly on a DIN TS-35 type rail
- Dedicated to the BIOTcloud lighting control system
- Lifetime of up to 100 000 h

Up-to-date product info and General Warranty Terms available on our website www.luglightfactory.com

AVAILABLE VERSIONS

Product version	Market	Mounting	Power supply	Dimensions [mm]
790030.001	EU	DIN TS-35 track	24 V DC	142.5 x 90.5 x 62.5
790030.101	Global	DIN TS-35 track	24 V DC	142.5 x 90.5 x 62.5

DIMENSIONS

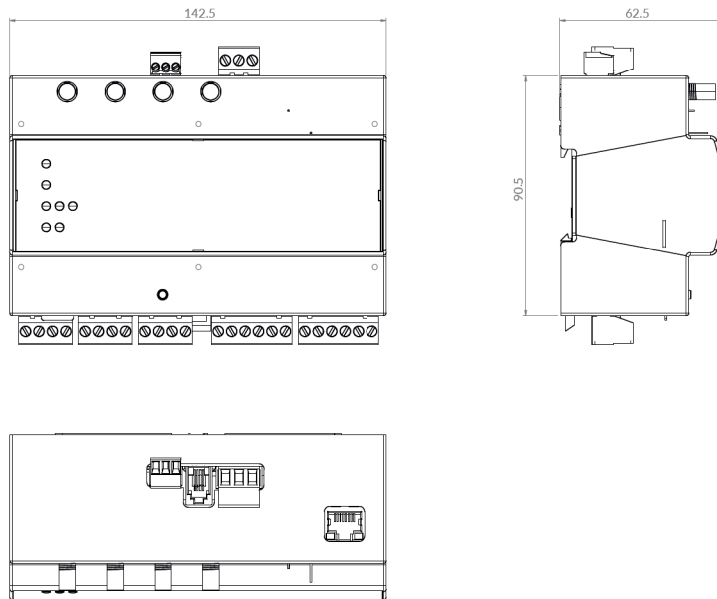

PRODUCT VIEWS

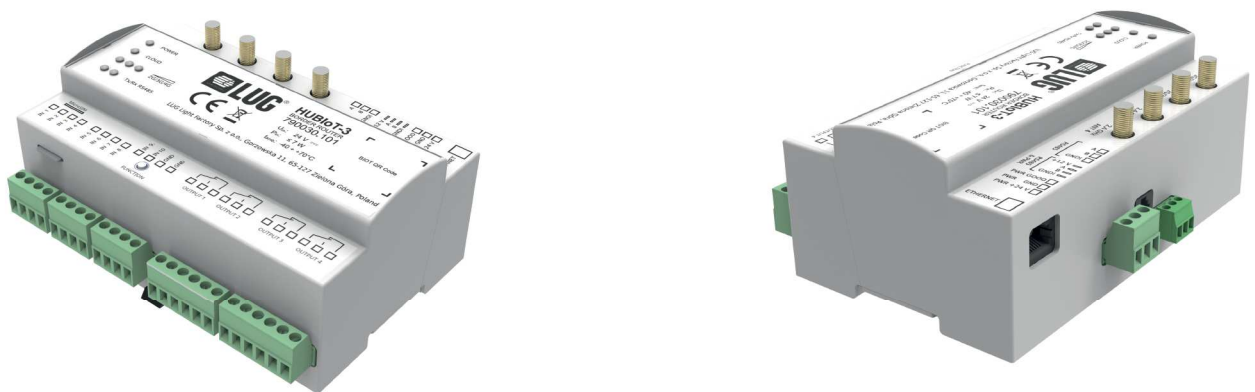

PRODUCT CONNECTORS

<p>2G/3G/4G ANT1 2G/3G/4G ANT2 2.4 GHz ANT3 2.4 GHz ANT4 RS485: A, B, GNDI RS485 & PWR: +12 V, A, B, GNDI PWR GOOD PWR GND PWR +24 V Ethernet IN1, ..., IN10 GND OUTPUT 1, ..., OUTPUT 4</p>	<p>Cell phone network antenna Additional cell phone network antenna Thread radio mesh antenna Thread radio mesh antenna Screw terminals for RS-485 Bus RJ9 connector for RS-485 Bus Proper power supply voltage signal Power ground Power supply RJ45 socket for LAN connection Control signal inputs (open-short) Ground for the control signals Control relays outputs</p>
--	--

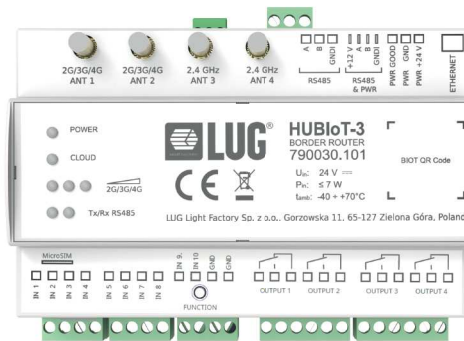

DEVICE PARAMETERS

<p>POWER SUPPLY</p>	<p>Voltage: 24 V DC +/- 10% Power consumption: 7 W</p>
<p>CONTROL SIGNALS</p>	<p>Binary inputs with pull-up resistors Switching voltage level: 4 V Max. input voltage: 24 V Max. input current (U=0): 10 mA</p>
<p>OUTPUTS</p>	<p>Max. switching voltage: 250 V rms Max. switching current (steady state): 3 A rms Min. no. of relay cycles: 10 000</p>
<p>ENVIRONMENTAL</p>	<p>Ambient temperature: -40 ... 75°C Storage temperature: -40 ... 85°C Relative humidity: 10 ... 90%</p>
<p>OTHER</p>	<p>Degree of protection: IP66 Radio frequency protocol: IEEE 802.15.4, 6LoWPAN, Thread Frequency band: 2.4 GHz Net weight: 1.3 kg Lifetime (Tamb = 70°C): 100 000 h</p>