

<b>Measurement Range:</b>	0-100 % oxygen
<b>Output in ambient air:</b>	13 to 16mV
<b>Electrical Interface:</b>	3pin (Molex 22-11-1031)
<b>Accuracy and Repeatability:</b>	< 1 % vol. O <sub>2</sub> when calibrated at 100 % Oxygen
<b>Linearity error:</b>	< 3 % relative
<b>Response time:</b>	< 12 sec. to 90 % of final value
<b>Zero Offset Voltage:</b>	< 200 µV in 100 % nitrogen applied for 5 min
<b>Cross Interference:</b>	< 0.5 % vol. O <sub>2</sub> response to: 10 % CO <sub>2</sub> balance N <sub>2</sub> 80% N <sub>2</sub> O balance N <sub>2</sub> 7.5% Halothane balance N <sub>2</sub> 7.5 % Isoflurane balance N <sub>2</sub> 7.5 % Enflurane balance N <sub>2</sub> 9% Sevoflurane balance N <sub>2</sub> 20% Desflurane balance N <sub>2</sub>
<b>Influence of Humidity:</b>	- 0.03 % rel. per % RH at 25°C
<b>Influence of Pressure:</b>	proportional to change in oxygen partial pressure
<b>Influence of Mechanical Shock:</b>	< 1% relative after a fall from 1m
<b>Operating Temperature:</b>	0 to 50°C
<b>Temperature Compensation:</b>	built-in NTC compensation
<b>Effect of Temperature Compensation (steady state):</b>	between +25°C and +40°C: 3 % relative error between 0 °C and +50 °C: 8 % relative error
<b>Operating Humidity:</b>	0-99 % RH non-condensing
<b>Long Term Output Drift:</b>	< 1 % vol oxygen per month typically < - 15 % relative over lifetime
<b>Storage Temperature:</b>	-20 to +50 °C
<b>Recommended Storage:</b>	+5 to +15 °C
<b>Recommended Load:</b>	≥ 10 kOhms
<b>Warm-Up Time:</b>	< 30 minutes, after replacement of sensor
<b>Nominal Sensor Lifetime:</b>	≥ 1.000 000 % vol oxygen hours
<b>Weight:</b>	approximately 28 grams
<b>Warranty Period:</b>	15 months
<b>Part No.:</b>	01-00-0047

**Use the advantages:**

- Meet DIN EN 21647
- Designed and manufactured according to EN ISO 9001 : 2000 and EN ISO 13485 : 2003
- Accurate and reliable response
- Resistant to N<sub>2</sub>O
- Excellent signal stability
- High product quality
- Short lead times
- Technical support

All specifications are applicable at standard conditions: 1013 hPa, 25°C dry ambient air

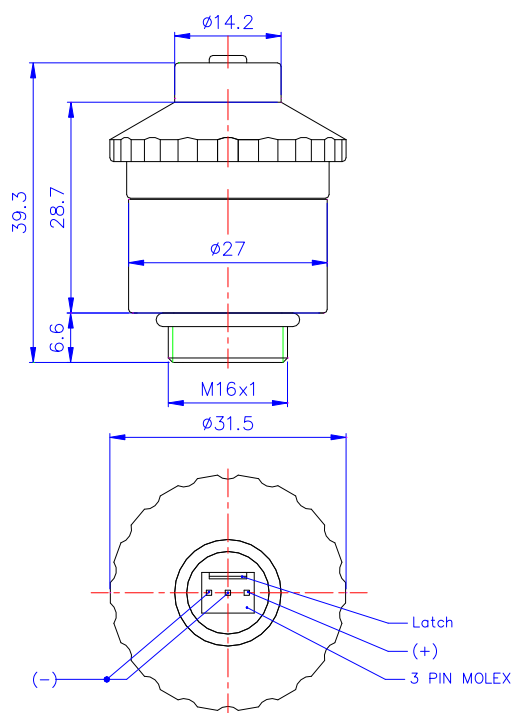

Dimension in mm

**ENVITEC- WISMAR GMBH**

Alter Holzhafen 18  
D-23966 Wismar

Phone: +49-(0) 3841- 360 1  
Fax: +49-(0) 3841- 360 222  
E-Mail: [info@envitec.com](mailto:info@envitec.com)  
<http://www.envitec.com>

# Flow Sensor SpiroQuant A+

## Use the advantages:

- Proven - constant temperature hot-wire anemometry
- Fast response time
- High product quality
- RoHS conform
- Biocompatible components
- Short delivery times
- Technical support
- Made in Germany
- Certified quality management system according EN ISO 13485

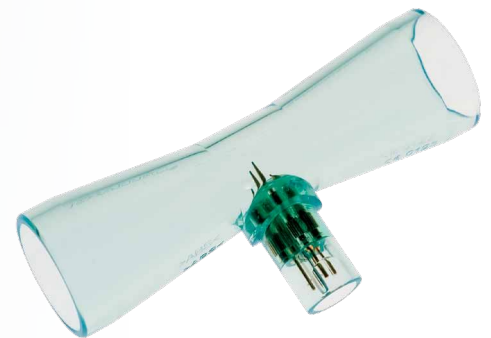

## „We keep your devices operating at their best.“

EnviteC has been developing and manufacturing highly specialized products for medical applications. EnviteC's research and development activities are consistently aligned to customer and market needs – identification and optimization of sustainable product solutions are the main concerns of the company.

The company trusts in the quality of advanced production methods and processes. The result are flow measurement solutions for medical applications, which share the same extraordinary quality, excellent signal stability and reliable response for accurate readings. The flow sensor SpiroQuant A+ is a hot-wire sensor for measuring volume gas flow in anesthesia machines and ventilators. The flow sensor is not suitable for sterilization. For operation please refer to the instructions for use of the basic device to which this sensor is connected.

## From standard sensors to customized sensors

Experienced EnviteC engineers analyze customer requirements. This input is used for different standard and OEM applications, and ongoing support is provided right up to the final integration in the solution. EnviteC designs customized sensors characterized by a maximum possible degree of precision.

## Mechanical drawing (All dimension in mm)

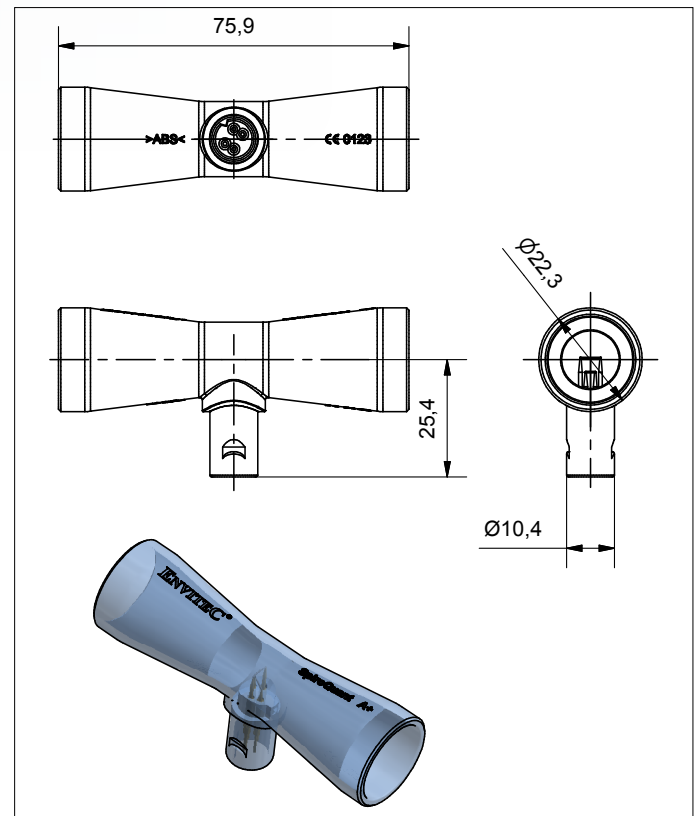

General tolerances ISO 2768-c

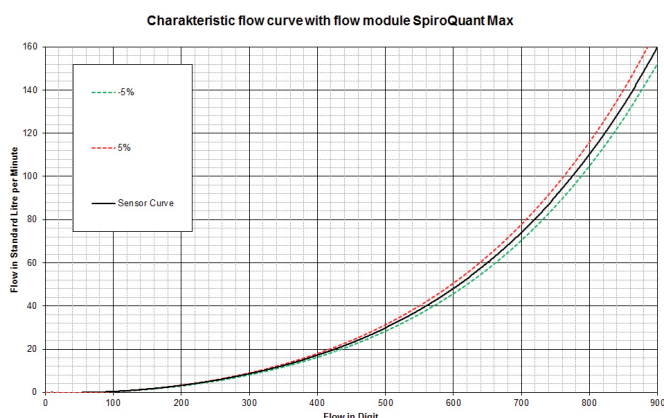

## Additional information

If the sensor is intended to replace the original flow-sensing component in anesthesia machines or ventilators, consult the EnviteC XRL Cross Reference List under [www. EnviteC.com](http://www.EnviteC.com) for selecting the appropriate sensor.

## For more information please contact us!

**We look forward to assisting you either on the phone or in a personal talk.**

## Technical Specifications SpiroQuant A+

Measuring principle	Constant temperature hot-wire anemometry
Cross reference	Designed for EnviteC SpiroQuant MAX module; compatible with Dräger Spirolog® flow sensor
Sensor type	Disposable sensor for single patient use
Flow range	0 ... 160 slpm (standard liters per minute)
Accuracy	± 7% from measured value between 0 ... 10 l/min with flow module SpiroQuant MAX; ± 5% from measured value between 10 ... 160 l/min with flow module SpiroQuant MAX; (± 8 % reading used in Dräger ventilators)
Flow resistance	< 2.5 mbar (added resistance)
Operating temperature	+15 °C ... +40 °C
Operating time	Single patient use, applicable as long as a sensor calibration is successful
Storage temperature	-20 °C ... +70 °C
Storage ambient pressure	570 ... 1200 hPa
Storage humidity	5 % ... 95 % RH in original packaging
Storage time	Max. 5 years in original packaging
Cleaning / disinfection	Single patient use
Weight	Approx. 10 g
Electrical connection	Gold plated 4 pin (compatible with Dräger Spirolog® sensor)
Material	Housing parts: MABS; Contact pins: gold-plated; Hot-wires: platin
Part number	1000470: Flow sensor SpiroQuant A+ (Box with 5 pieces); 1001487: Flow module SpiroQuant MAX

All specifications are applicable at standard conditions:  
1013 hPa, 25 °C dry ambient air



### Certified Quality Management

EnviteC is maintaining a quality management system, which meets the requirements of EN ISO 13485 for medical devices.

### EnviteC-Wismar GmbH a Honeywell Company

Alter Holzhafen 18, 23966 Wismar, Germany

Phone: +49 (0)3841-360-1

Phone: +49 (0)3841-360-200

Fax: +49 (0)3841-360-222

Internet: [www.envitec.com](http://www.envitec.com)

Email: [info@envitec.com](mailto:info@envitec.com)

Doc. No. 007-05-SpiroQuant\_A+\_Spec-0

December 2017

Technical information is subject  
to change without notice!

© 2017 Honeywell International Inc.

EnviteC by Honeywell reserves the  
right to make changes in product  
specifications and adjust its production  
at any time and without notice.

**ENVITEC**  
by Honeywell

# Oxygen Sensor OOM201

## Use the advantages:

- Compliant with European MDD (CE certification)
- Meets ISO 80601-2-55
- Designed and manufactured according to EN ISO 13485
- Accurate and reliable fast response
- Resistant to N<sub>2</sub>O
- Excellent signal stability
- High product quality
- Short delivery times
- Technical support
- Made in Germany
- FDA cleared



## From standard sensors to customized sensors

Experienced EnviteC engineers analyze customer requirements. This input is used for different standard and OEM applications, and ongoing support is provided right up to the final integrator in the solution. EnviteC designs customized sensors characterized by a maximum possible degree of precision, for example with different signal levels or temperature compensation elements.

## Intendend use

The EnviteC Medical Oxygen Sensors are intended as oxygen-sensing component of an oxygen analyzer that measures oxygen concentration in breathing gas mixtures in the following applications:

Sensing device for oxygen in

- control device of oxygen concentrators
- medical ventilators
- anaesthesia equipment
- incubators.

The use is limited to system monitoring. The sensors are not suited for breath by breath analysis of breath gases. Please refer to the Instructions for Use! If the sensor is intended to replace the original oxygen-sensing component of an oxygen analyzer, consult the EnviteC XRL Cross Reference List for selecting the appropriate sensor.



## Mechanical drawing (All dimension in mm)

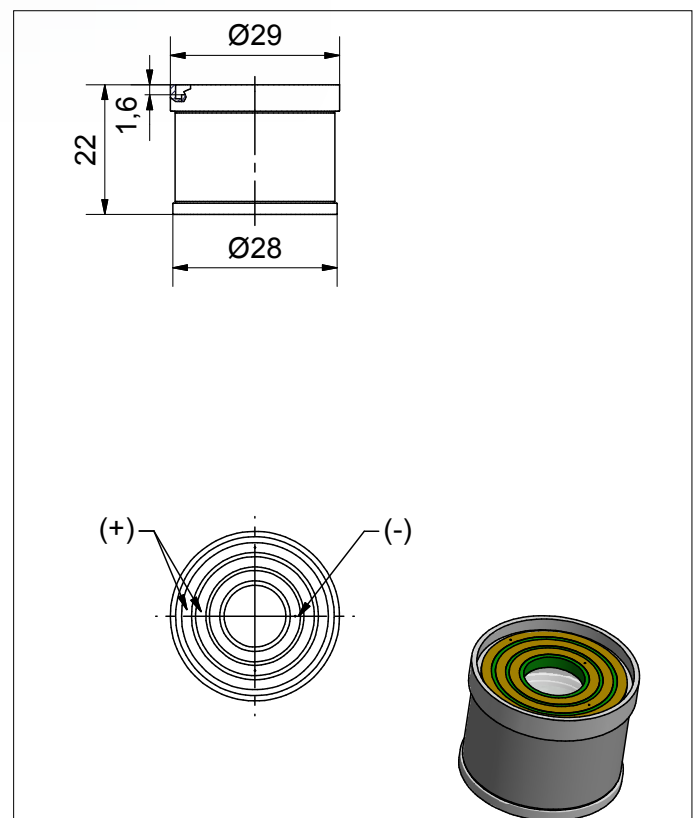

General tolerances ISO 2768-c

## Additional information

The Instructions for Use as well as the EnviteC XRL Cross Reference List are available under [www.EnviteC.com](http://www.EnviteC.com) and in the Apple App Store under EnviteC XRL as free download.

## For more information please contact us!

**We look forward to assisting you either on the phone or in a personal talk.**

## Technical Specifications OOM201

Measurement range	0 % ... 100 % oxygen (at atmospheric pressure)
Nominal sensor lifetime	≥ 500 000 % volume oxygen hours
Output in ambient air	14 mV ... 20.7 mV (Dual Cathode), load 600 Ohms
Electrical interface	Gold plated slip rings
Accuracy	meets ISO 80601-2-55 requirements
Repeatability	< 1 % volume O <sub>2</sub> at constant temperature and pressure
Linearity error	< 3 % relative
Response time	< 12 s to 90 % of final value
Zero offset voltage	< 200 µV in 100 % nitrogen, applied for 5 min
Cross interference	meets ISO 80601-2-55 requirements
Influence of humidity	-0.03 % rel. per % RH at 25 °C
Pressure range	0.6 bar ... 2 bar (ppO <sub>2</sub> 0 ... 1250 mbar O <sub>2</sub> )
Influence of pressure	proportional to change in oxygen partial pressure
Influence of mechanical shock	< 1 % relative after a fall from 1 m
Operating temperature	0 °C ... +50 °C
Temperature compensation	no temperature compensation
Operating humidity	0 % ... 99 % RH non-condensing
Long term output drift	< 1 % volume oxygen per month typically < -15 % relative over lifetime
Storage temperature	-20 °C ... +50 °C
Recommended storage	+5 °C ... +15 °C
Recommended load	≥ 10 kOhms
Warm-up time	< 30 minutes, after replacement of sensor
Weight	approximately 28 grams
Part number	01-00-0014

All specifications are applicable at standard conditions:  
1013 hPa, 25 °C dry ambient air



For suitable accessories and sensors please refer to the EnviteC Cross Reference List under [www.EnviteC.com](http://www.EnviteC.com) and in the Apple App Store under EnviteC XRL as free download.

**EnviteC-Wismar GmbH**  
**a Honeywell Company**

Alter Holzhafen 18, 23966 Wismar, Germany

Phone: +49 (0)3841-360-1

Phone: +49 (0)3841-360-200

Fax: +49 (0)3841-360-222

Internet: [www.envitec.com](http://www.envitec.com)

Email: [info@envitec.com](mailto:info@envitec.com)

Doc. No. 001-33-Datasheet\_OOM201-0

March 2016

Technical information is subject  
to change without notice!

© 2016 Honeywell International Inc.

EnviteC by Honeywell reserves the  
right to make changes in product  
specifications and adjust its production  
at any time and without notice.

**ENVITEC**  
by Honeywell

# Flow Sensor SpiroQuant H

## Use the advantages:

- Proven passive flow differential pressure converter
- Measuring of breathing gas flow in adult applications
- High product quality
- RoHS conform
- Biocompatible components
- Short delivery times
- Technical support
- Made in Germany
- Certified quality management system according EN ISO 13485



## „We keep your devices operating at their best.“

EnviteC has been developing and manufacturing highly specialized products for medical applications. EnviteC's research and development activities are consistently aligned to customer and market needs – identification and optimization of sustainable product solutions are the main concerns of the company.

The company trusts in the quality of advanced production methods and processes. The result are flow measurement solutions for medical applications, which share the same extraordinary quality, excellent signal stability and reliable response for accurate readings. The Flow sensor SpiroQuant H is a passive flow differential pressure converter for measuring of breathing gas flow in connection with the appropriate measuring unit (differential pressure gauge). The sensor is designed as disposable sensor for single patient use in adult applications. A re-use or cleaning is not allowed.

## From standard sensors to customized sensors

Experienced EnviteC engineers analyze customer requirements. This input is used for different standard and OEM applications, and ongoing support is provided right up to the final integration in the solution. EnviteC designs customized sensors characterized by a maximum possible degree of precision.

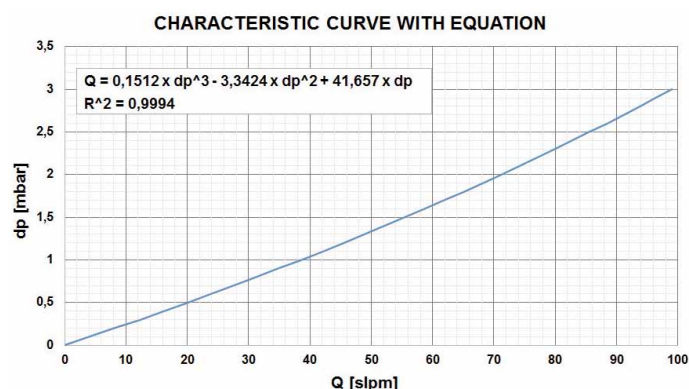

## Mechanical drawing (All dimension in mm)

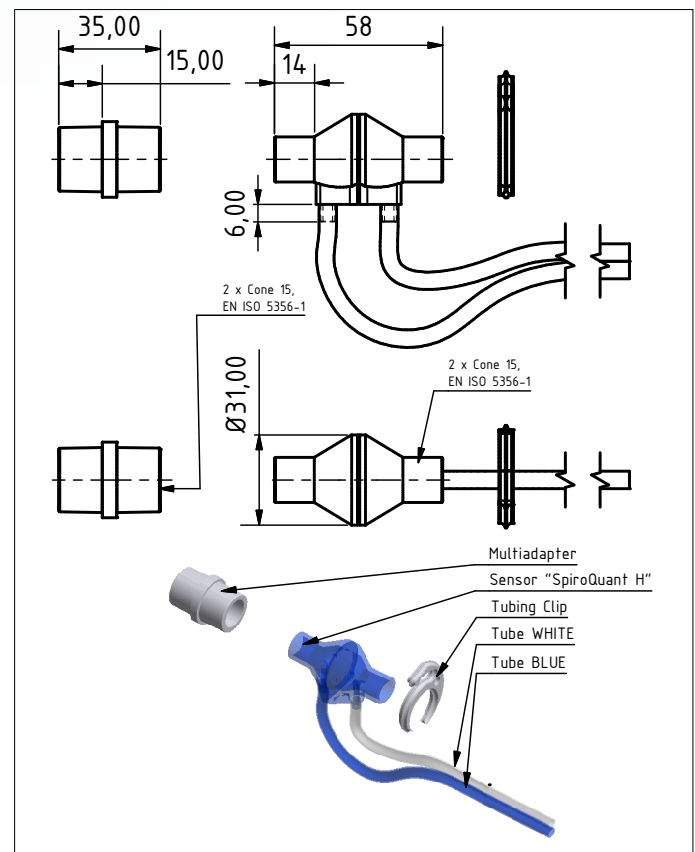

General tolerances ISO 2768-c

## Additional information

If the sensor is intended to replace the original flow-sensing component in anesthesia machines or ventilators, consult the EnviteC XRL Cross Reference List under [www.EnviteC.com](http://www.EnviteC.com) for selecting the appropriate sensor.

## For more information please contact us!

**We look forward to assisting you either on the phone or in a personal talk.**

## Technical Specifications SpiroQuant H

Measuring principle	Differential pressure principle
Cross reference	Compatible to Hamilton flow sensor PN 279331
Sensor type	Disposable sensor for single patient use
Application	Adult applications
Flow range	0 ... 100 slpm (standard liters per minute)
Accuracy	± 15 % over measuring range
Flow resistance	Approx. 1.0 mbar equals 60 slpm
Operating temperature	0 °C ... +50 °C
Operating humidity	5 ... 95 % RH non-condensing
Operating conditions	570 ... 1200 hPa only with external pressure compensation
Operating time	Single patient use, applicable as long as a sensor calibration is successful
Storage temperature	-20 °C ... +70 °C
Storage ambient pressure	570 ... 1200 hPa
Storage humidity	5 % ... 95 % RH non-condensing
Storage time	Max. 5 years
Dead space	11 cm <sup>3</sup> (without cone adaption)
Cleaning / disinfection	No re-use, cleaning or disinfection not allowed
Weight	Sensor without tubes: approx. 11 g; Sensor incl. tubes: approx. 51 g
Material	Housing parts: MABS; Inner part: PET; Tube: PVC - medical grade; Tube length: 1.8 m; Tube diameters: dI 0 3.0 mm -0.1 +0.05; dA = 4.6 mm
Part number	07-00-0001: SpiroQuant H (Pack with 6 pieces incl. clip and adapter); 07-000027: Tubing clip; 07-000025: Multi adapter

All specifications are applicable at standard conditions:  
1013 hPa, 25 °C dry ambient air



### Certified Quality Management

EnviteC is maintaining a quality management system, which meets the requirements of EN ISO 13485 for medical devices.

### EnviteC-Wismar GmbH a Honeywell Company

Alter Holzhafen 18, 23966 Wismar, Germany

Phone: +49 (0)3841-360-1

Phone: +49 (0)3841-360-200

Fax: +49 (0)3841-360-222

Internet: [www.envitec.com](http://www.envitec.com)

Email: [info@envitec.com](mailto:info@envitec.com)

Doc. No. 007-05-SpiroQuant\_H\_Spec-0

December 2017

Technical information is subject  
to change without notice!

© 2017 Honeywell International Inc.

EnviteC by Honeywell reserves the  
right to make changes in product  
specifications and adjust its production  
at any time and without notice.

**ENVITEC**  
by Honeywell







America

# CERTIFICATE

No. QS6 021697 0022 Rev. 00

**Certificate Holder:** **EnviteC - Wismar GmbH**  
Alter Holzhafen 18  
23966 Wismar  
GERMANY

**Certification Mark:**



**Scope of Certificate:** **Design and Development, Production and Distribution of Sensors and Control Units for Monitoring of Vital Physiological Parameters, Sensors and Control Units for Monitoring of Respiratory Mechanics Parameters and Gas Exchange**

**Standard(s):** **ISO 13485:2016**

**Regulatory Authority(ies):** **Australia TGA, Health Canada, USA FDA, MHLW / PMDA.**  
**See attached for listing of specific regulatory requirements.**

The Certification Body of TÜV SÜD America Inc. certifies that the quality management system of the manufacturer listed above has been audited against the stated criteria and found to conform to those criteria for the scope of certification listed. Validity of this certificate can be obtained by visiting the website [www.tuvsud.com/ps-cert](http://www.tuvsud.com/ps-cert)  
TÜV SÜD America Inc. is an MDSAP Recognized Auditing Organization.

**DUNS No:** **33-094-3838**

**Effective Date:** **2021-03-10**

**Expiry Date:** **2022-01-28**

Page 1 of 2

**Date of Issue:** 2021-03-18

( Tina Israel )  
Manager, US Certification Body,  
Medical and Health Services



America

# CERTIFICATE

No. QS6 021697 0022 Rev. 00

**Regulatory Requirements:      Audit/Certification Criteria**

**Australia**

Therapeutic Goods (Medical Devices) Regulations 2002  
 - Schedule 3, Part 1 (excluding Part 1.6) – Full Quality Assurance Procedure

**Canada**

- Medical Device Regulations – Part 1- SOR 98/282

**Japan**

- MHLW Ministerial Ordinance 169, Article 4 to Article 68  
 - PMD Act

**United States**

- 21 CFR Part 803  
 - 21 CFR Part 806  
 - 21 CFR Part 807 – Subparts A to D  
 - 21 CFR Part 820

**Facility(ies):**

EnviteC - Wismar GmbH  
 Alter Holzhafen 18, 23966 Wismar, GERMANY

**Facility Scopes:**

Design and Development, Production and Distribution of Sensors and Control Units for Monitoring of Vital Physiological Parameters, Sensors and Control Units for Monitoring of Respiratory Mechanics Parameters and Gas Exchange  
 DUNS No: 33-094-3838

Page 2 of 2

Date of Issue: 2021-03-18

( Tina Israel )  
 Manager, US Certification Body,  
 Medical and Health Services