

STORZ

KARL STORZ — ENDOSKOPE

en **Instructions for use**
AUTOCON III 400



ATTENTION:

USA CUSTOMERS: Please note the following content is not applicable to U.S. customers. U.S. instructions can be found here:

<https://www.karlstorz.com/>

CANADIAN CUSTOMERS: For the applicable instructions for use for Canadian customers, please access the instructions:

<https://www.karlstorz.com/>



04-2025

Copyright ©

All product illustrations, product descriptions, and texts are the intellectual property of KARL STORZ SE & Co. KG.

Their use and reproduction by third parties require the express approval of KARL STORZ SE & Co. KG.

All rights reserved.

Table of contents

1	General information	7
1.1	Read the instructions for use	7
1.2	Read the instructions for use of compatible products	7
1.3	Scope	7
1.4	General signs and symbols	7
1.5	Description of warning messages	8
2	Normal use	9
2.1	Intended use	9
2.2	Indications	9
2.3	Contraindications	9
2.4	Clinical benefits	9
2.5	Residual risks	9
2.6	Target user populations	9
2.7	Patient population	9
3	Safety and warning	10
3.1	Serious incidents	10
3.2	Correct handling and product testing	10
3.3	Product not clean	10
3.4	Combination with other components	10
3.5	Dangers from electrical current	11
3.6	Damage due to ingress of liquid in electrical components	11
3.7	Risk of explosion and fire	11
3.8	Electromagnetic interference	12
3.9	Patients with pacemakers	12
3.10	Positioning the patient safely	12
3.11	Failure of products	13
3.12	Observing ambient conditions	13
3.13	Risks in IT networks	13
4	Product description	14
4.1	Product overview	14
4.1.1	Front panel	14
4.1.2	Back panel	16
4.1.3	Footswitch	17
4.2	Possible combinations	17
4.3	Technical data	19
4.4	Symbols employed	20
4.4.1	Symbols on the packaging	20
4.4.2	Symbols on the product	21
4.4.3	Symbols on the type plate	22
4.5	Ambient conditions	23
5	Preparation	24
5.1	Unpacking the product	24
5.2	Reprocessing the product	24
5.3	Setting up the product	24
5.4	Connecting the product	25

5.5	Switching on the product	25
5.6	Connecting monopolar instruments	26
5.7	Connecting bipolar instruments	26
5.8	Connecting the footswitch	26
5.9	Checking the functions	26
5.10	Neutral electrode monitoring	27
5.10.1	EASY monitoring	27
6	Application	28
6.1	Notes on use	28
6.2	Using the accessories	28
6.3	Using the neutral electrode	29
6.3.1	Using the disposable electrode	30
6.4	Main screen	30
6.5	Unlocking the screen	31
6.6	Switching sockets on and off	31
6.7	Setting the sockets	32
6.7.1	Selecting the mode	32
6.7.2	Setting the power output	38
6.7.3	Selecting the effect	39
6.7.4	Assigning the footswitch	39
6.7.5	Selecting the neutral electrode	42
6.7.6	Coding system	44
6.8	Menu	45
6.8.1	Programs	45
6.8.2	Saving a program	47
6.8.3	Favorites	47
6.8.4	Socket configuration	48
6.8.5	System settings	50
6.8.6	Service	52
6.8.7	Adjusting the volume	53
6.8.8	System information	54
6.9	System messages	55
6.10	Switching off the product	56
7	Maintenance, servicing, repairs, and disposal	57
7.1	Maintaining the product	57
7.1.1	Maintenance	57
7.2	Safety inspection in accordance with IEC 62353	57
7.2.1	Visual inspection	57
7.2.2	Electric measurements	57
7.2.3	Functional test	57
7.3	Repairs to the product	57
7.4	Disposing of the product	58
8	Accessories and spare parts	59
8.1	Accessories	59
8.2	Spare parts	60
9	Electromagnetic compatibility	61
9.1	General notes on the operating environment	61
9.2	Key performance characteristics	61

9.3	Accessories, transducers, and cables	61
9.4	Test-Tables	62
9.4.1	Table 1 – Compliance level for immunity tests	62
9.4.2	Table 2 – Test levels for near fields from HF wireless communications equipment ...	63
9.4.3	Table 3 – Test levels for radiated and conducted immunity tests	64
9.4.4	Table 4 – Emission class and group	65
9.4.5	Table 5 – Recommended separation distances between portable and mobile HF communications equipment and the product	66
10	Errors and messages	67
10.1	Troubleshooting	67
10.2	EASY monitoring fault indication	67
10.3	System messages	67
11	Appendix	71
11.1	Monopolar modes	71
11.2	Bipolar modes	77
11.3	Output, voltage, and current diagrams	81
11.3.1	Monopolar Cutting – Cut reduced 200 W	81
11.3.2	Monopolar Cutting – Cut	82
11.3.3	Monopolar Cutting – Cut reduced 50 W	83
11.3.4	Monopolar Cutting – Resection	85
11.3.5	Monopolar Cutting – Cut 300–400 W	86
11.3.6	Monopolar Cutting – Cut blend	86
11.3.7	Monopolar Cutting – Intermittent 400 W 1	88
11.3.8	Monopolar Cutting – Intermittent 400 W 2	89
11.3.9	Monopolar Cutting – Intermittent 400 W 3	90
11.3.10	Monopolar Cutting – Intermittent 300 W 1	92
11.3.11	Monopolar Cutting – Intermittent 300 W 2	93
11.3.12	Monopolar Cutting – Intermittent 300 W 3	94
11.3.13	Monopolar Coagulation – Forced Coag 1.8 kVp	96
11.3.14	Monopolar Coagulation – Soft Contact	97
11.3.15	Monopolar Coagulation – Forced Coag	99
11.3.16	Monopolar Coagulation – Resection	100
11.3.17	Monopolar Coagulation – Spray	101
11.3.18	Monopolar Coagulation – Forced mixed	102
11.3.19	Monopolar Coagulation – Forced Coag with Cut	103
11.3.20	Bipolar Cutting – Bip. Cutting	105
11.3.21	Bipolar Cutting – Bipolar Scissors	106
11.3.22	Bipolar Cutting – Bip. Resection 15 Fr.	107
11.3.23	Bipolar Cutting – Bip. Resection	108
11.3.24	Bipolar Cutting – Bip. Vaporization	109
11.3.25	Bipolar Cutting – VAP CUT	109
11.3.26	Bipolar coagulation – RoBi	110
11.3.27	Bipolar Coagulation – Standard plus	111
11.3.28	Bipolar Coagulation – Standard	112
11.3.29	Bipolar Coagulation – Bip. Resection 15 Fr.	113
11.3.30	Bipolar Coagulation – Bip. Resection	114
11.3.31	Bipolar Coagulation – Bip. Vaporization	115
11.3.32	Bipolar Coagulation – VAP COAG	116
11.3.33	Bipolar Coagulation – Standard AUTO	117
11.3.34	Bipolar Coagulation – Bipolar Scissors	118
11.3.35	Bipolar Coagulation – Micro	119

11.3.36 Bipolar Coagulation – Forced 120

12 Subsidiaries 121

1 General information

1.1 Read the instructions for use

If the instructions for use are not followed, patients, users, and third parties may be injured or the product may be damaged.

- ▶ Read the instructions for use carefully and follow all the safety notes and warnings.
- ▶ Read the reprocessing instructions carefully and follow all the safety notes and warnings. The reprocessing instructions can be downloaded from www.karlstorz.com/ifu by entering the item number.
- ▶ Keep the instructions for use and reprocessing instructions in a safe place.

1.2 Read the instructions for use of compatible products

If the instructions for use of compatible products are not followed, patients, users, and third parties may be injured or the product may be damaged.

- ▶ Read the instructions for use of the compatible products carefully and follow all the safety notes and warnings.
- ▶ Read the reprocessing instructions of the compatible products carefully and follow all the safety notes and warnings.

1.3 Scope

The products listed here may not yet be available in all countries due to differences in approval requirements.

This instruction manual is valid for:

HF generators

Product name	Item number
AUTOCON III 400 CE, 220–240 V	UH400E
AUTOCON III 400 CE, 100–127 V	UH400UE

Footswitches

Product name	Item number
One-pedal Footswitch – HF Generators	UF901
Two-pedal Footswitch – HF Generators	UF902

1.4 General signs and symbols

The signs and symbols used in this document have the following meaning:

Practical tip

-  This sign refers to useful and important information.

Actions to be performed

Action to be carried out by several steps:

- ✓ Prerequisite that must be met before carrying out an action.

1. Step 1
 - ⇒ Interim result of an action
2. Step 2
 - ⇒ Result of a completed action

Actions in the case of a single step:

- ▶ Step 1

Actions in safety notes:

- ▷ Step 1
- ▷ Step 2

Lists

1. Numbered list
 - Unnumbered list, 1st level
 - Unnumbered list, 2nd level

1.5 Description of warning messages

To prevent any injury to persons or damage to property, the warnings and safety notes in the instructions for use must be observed. The warnings use the following levels of danger:

▲ WARNING

WARNING

Designates a possible imminent risk. If this is not avoided, it could lead to death or serious injuries.

▲ CAUTION

CAUTION

Designates a possible imminent risk. If this is not avoided, it could lead to minor injuries.

NOTICE

NOTICE

Designates a possibly harmful situation. If this is not avoided, the products could be damaged.

2 Normal use

2.1 Intended use

High-frequency generators

High-frequency generators are intended to provide electrical power for high-frequency surgical application parts. High-frequency generators do not have body contact.

Footswitches

Footswitches are intended to activate and control functions of medical devices. Footswitches do not have body contact.

2.2 Indications

The high-frequency generator with the corresponding accessories is suitable for all application parts that require the energies provided in the chapter "Technical data" of the corresponding instructions for use for successful performance.

2.3 Contraindications

The high-frequency generator with the corresponding accessories is not used in direct contact with the patient, but provides energy and power for HF application parts. Use with the corresponding application parts is contraindicated if the use of these application parts is contraindicated.

The unit is not suitable for application parts that require continuous activation of the high-frequency generator.

2.4 Clinical benefits

Unlike mechanical transection of tissue, electrocautery uses a short, intense electric current that transects or vaporizes tissue, depending on the duration of application. Electrocautery in surgery is now widely used in virtually all routine operations, particularly as a viable, rapid, and essentially harmless means of obliterating small and medium-sized blood vessels for the purpose of intraoperative hemostasis.

2.5 Residual risks

No residual risks directly related to the product were identified.

2.6 Target user populations

The medical device may only be used by doctors and medical assistants with a relevant specialist qualification.

2.7 Patient population

There are no restrictions in terms of patient groups for this product.

The product does not come into direct contact with the patient.

3 Safety and warning

⚠ WARNING

Danger due to non-observance of warnings and safety notes

This chapter contains warnings and safety notes structured according to hazards and risks.

- ▷ Carefully read and observe all warnings and safety notes.
- ▷ Follow the instructions.

3.1 Serious incidents

A 'serious incident' includes incidents which, directly or indirectly, had, could have had or could have any of the following consequences:

- Death of a patient, user, or another person
- Temporary or permanent serious deterioration in the medical condition of a patient, user, or another person
- A serious threat to public health
- ▶ The manufacturer and appropriate authority must be notified of all serious incidents.

3.2 Correct handling and product testing

If the product is not handled correctly, patients, users, and third parties may be injured.

- ▶ Only persons with the necessary medical qualification and who are acquainted with the application of the product may work with it.
- ▶ Check that the product is suitable for the procedure prior to use.
- ▶ Check the product for the following properties, for example, before and after every use:
 - Functionality
 - Damage
 - Changes to the surface
 - In the case of several components: completeness and correct assembly
- ▶ Do not continue to use damaged products.
- ▶ Dispose of the product properly; see *Disposing of the product*.

3.3 Product not clean

The product is not clean when delivered. The use of products that have not been cleaned poses a risk of infection for patients, users, and third parties.

- ▶ Reprocess the product in line with the reprocessing instructions before initial use and every subsequent use.

3.4 Combination with other components

The use of unauthorized devices and components may result in injuries.

- ▶ Ensure that any additional devices connected to electrical medical devices comply with the relevant IEC or ISO standards.
- ▶ Ensure that all configurations comply with the requirements for medical electrical systems.
- ▶ Only combine the product with devices and components that the manufacturer has approved for combined use, see chapter *Possible combinations*.
- ▶ Do not modify this equipment without authorization of the manufacturer.

- ▶ Observe the instruction manuals and interface specifications of the devices and components used in combination.
- ▶ Make sure that the set peak voltage output does not exceed the maximum permissible peak voltage output of the connection accessory.

3.5 Dangers from electrical current

An improper power supply may cause an electric shock and injure patients, users, or third parties.

- ▶ Ensure that all electrical installations of the operation room in which the product is connected and used conform with the applicable IEC standards.
- ▶ Use either the power cord supplied by KARL STORZ or a power cord which has the same properties and which bears a national mark of conformity.
- ▶ The product may only be operated with the line voltage stated on the rating plate.
- ▶ Position the product appropriately so that the power cord can be unplugged at any time. The product is only voltage-free when the mains plug has been disconnected.
- ▶ Ensure potential equalization according to the applicable national rules and regulations.
- ▶ The product's ground line should be installed by a qualified electrician.
- ▶ To ensure reliable protective earth grounding, connect the product to a properly installed socket that is approved for use in the operation room.
- ▶ Connect the product to a power supply with protective conductor.

In the case of electrical products, individual components or the product itself may be live. Live parts can cause electric shocks in the event of contact and injure patients, users, and third parties.

- ▶ Always pull out the mains plug before carrying out any cleaning and maintenance work.
- ▶ Do not touch the output jacks of the product and the patient at the same time during use

3.6 Damage due to ingress of liquid in electrical components

In the case of electrical products, individual components or the product itself may be live. Liquid ingress into an electrical product may result in a short circuit or an unintentional transfer of current. The product is damaged as a result and patients, users and third parties may be injured.

- ▶ Do not store liquids near the product or on the product.
- ▶ If liquid has entered the product, pull out the plug and allow the product to dry completely.

3.7 Risk of explosion and fire

The product can generate sparks, which cause combustible or flammable gases and liquids to ignite or explode. This may cause injuries to patients, users, or third parties.

- ▶ The product must not be operated in oxygenated environments.
- ▶ Do not operate the product in explosive atmospheres.

- ▶ Do not operate the product in environments with combustible gases such as inhalation anesthetics and mixtures thereof. Observe the hazard zones:

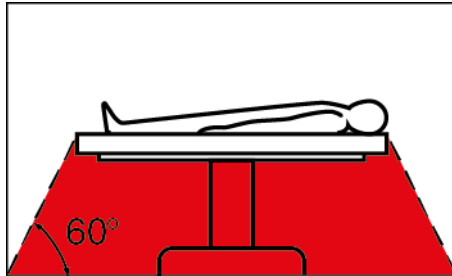

- ▶ Combustible and flammable gases must be allowed to escape, be extracted, or be displaced with CO₂ before use.
- ▶ Use non-combustible cleaning agents and disinfectants where possible.
- ▶ Combustible and flammable liquids such as cleaning and disinfecting solutions must be allowed to vaporize, or be wiped away or extracted before use.
- ▶ Remove any swabs or cloths soaked in flammable liquid from the application area.
- ▶ Only start the application when combustible or flammable gases and liquids are no longer present.
- ▶ Only connect or disconnect the power plug to or from the power supply outside explosive atmospheres.

3.8 Electromagnetic interference

Medical electrical devices are subject to special precautions regarding electromagnetic compatibility. If other devices (e.g., MRT, CT, diathermy, electrocautery, or RFID) emit electromagnetic radiation, the product's functionality may be impaired. High-frequency (HF) communication equipment can affect electrical medical devices and impair their performance.

- ▶ During installation and operation of the product, please take note of the information on electromagnetic compatibility, see chapter *Electromagnetic compatibility*.

3.9 Patients with pacemakers

Anything that results in the destruction of the pacemaker or causes it to malfunction is extremely dangerous and may cause irreversible injury to the patient.

- ▶ In the case of patients with pacemakers, consult the cardiologist before carrying out HF surgery.
- ▶ Use bipolar HF methods.
- ▶ Attach the HF neutral electrodes close to the operating field.
- ▶ Set the demand pacemaker to a fixed frequency.
- ▶ Ensure that the pacemaker does not come into contact with the HF electrode.
- ▶ Keep a fully operational defibrillator within reach.
- ▶ Carry out a postoperative pacemaker check.

3.10 Positioning the patient safely

If the patient is not positioned correctly, there is a risk of electric shock.

- ▶ Position patients away from metal parts that are grounded or have considerable capacitance relative to ground, such as operating table brackets.
- ▶ Ensure that the patient does not touch any wet cloths or underlays.

- ▶ Place anti-static cloths between areas with heavy sweating and skin-to-skin contact areas on the patient's torso.
- ▶ Drain urine via a catheter.

3.11 Failure of products

The product may fail during use.

- ▶ Have a replacement product ready for each application or plan for an alternative surgical technique.

3.12 Observing ambient conditions

If the device is stored, transported, operated or reprocessed under unsuitable conditions, patients, users or third parties may be injured and the device can be damaged.

- ▶ Observe the ambient conditions listed in the instructions for use and reprocessing.

3.13 Risks in IT networks

The product is not designed for connection to a public IT network. The integration of the product in a public IT network can interfere with the function of the product.

- ▶ Do not connect the product to a public IT network or to other devices designed for this.
- ▶ The USB and Ethernet interfaces may only be used by KARL STORZ service personnel and personnel authorized by KARL STORZ.

4 Product description

4.1 Product overview

4.1.1 Front panel



AUTOCON III 400 – Front view

- | | | | |
|---|--|---|--|
| 1 | Connection sockets for monopolar instruments | 5 | Touch screen |
| 2 | Connection socket for neutral electrode | 6 | Activation bar for top and bottom bipolar socket |
| 3 | Standby button | 7 | Connection sockets for bipolar instruments |
| 4 | Activation bar for top and bottom monopolar socket | | |

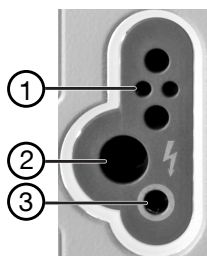

Monopolar connection socket, top

- 1 3-pin US type
- 2 5 mm KARL STORZ/Erbe VIO
- 3 4 mm socket (foot-switched)

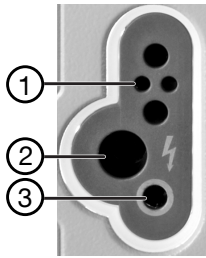

Monopolar connection socket, bottom

- 1 3-pin US type
- 2 BOVIE (foot-switched)
- 3 4 mm socket (foot-switched)

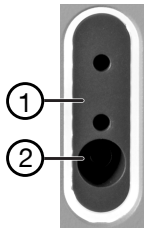

Bipolar connection socket, top

- 1 2-pin US type (28.58 mm)
- 2 KARL STORZ/Erbe VIO

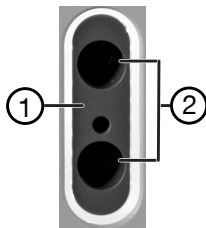

Bipolar connection socket, bottom

- 1 2-pin US type (28.58 mm)
- 2 KARL STORZ/Erbe VIO

4.1.2 Back panel

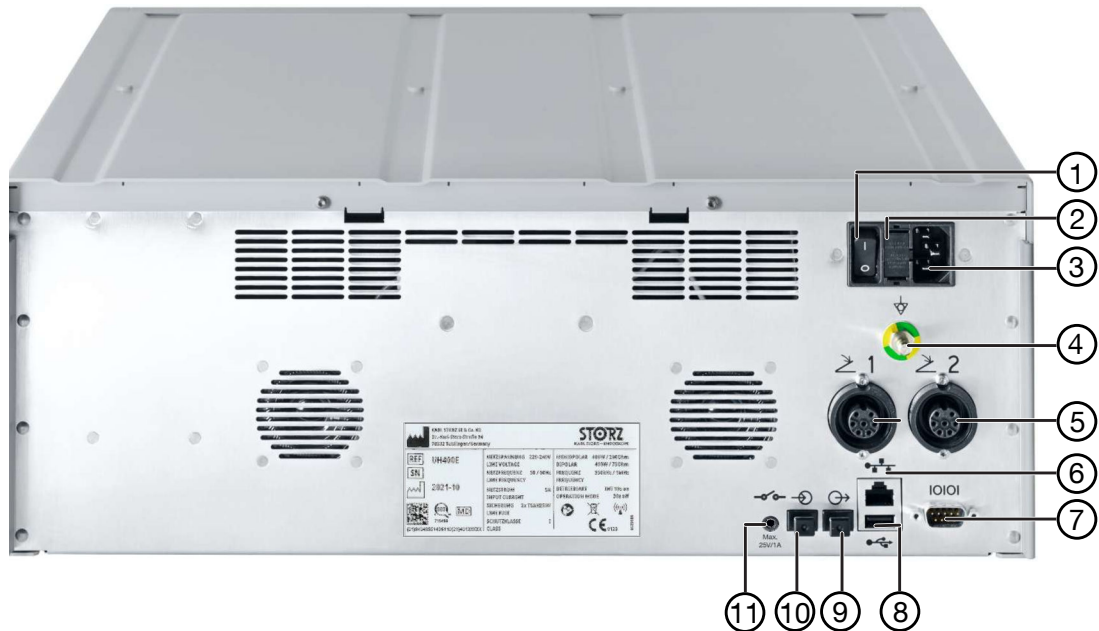

AUTOCON III 400 – Rear view

- | | | | |
|---|---|----|---|
| 1 | Power switch | 7 | UART communication interface |
| 2 | Line fuses | 8 | USB interface |
| 3 | Power socket | 9 | Fiber-optic signal output socket |
| 4 | Potential equalization connector | 10 | Fiber-optic signal input socket |
| 5 | Connection sockets for footswitches | 11 | Connector for S-PILOT (UP501) with connecting cable (UP004), Ø 3.5 mm |
| 6 | Ethernet interface for KARL STORZ OR1 control NEO | | |

The following connectors should only be used for service and training:

- Line fuses
- UART communication interface
- USB interface

4.1.3 Footswitch



One-pedal Footswitch – HF Generators (UF901)

- 1 Coagulation button
- 2 Changeover switch

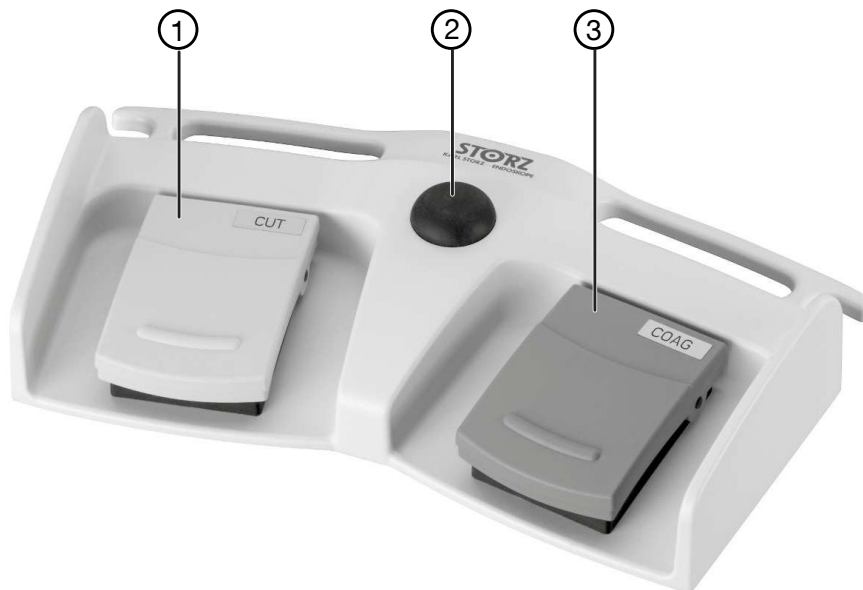

Two-pedal Footswitch – HF Generators (UF902)

- 1 Cutting button
- 2 Changeover switch
- 3 Coagulation button

4.2 Possible combinations

It is recommended that the suitability of the products for the intended procedure be checked prior to use. Please note that the described products in this medium may not be available in all countries due to different regulatory requirements.

Only combine the product with instruments and devices that are approved for joint use. Observe the product's maximum peak voltage output when combining.

The product can be combined with the following components:

Product name	Item number
S-PILOT	UP501
KARL STORZ SCB Control OR1 – control NEO	WU300
KARL STORZ OR1 – control NEO	WU300
KARL STORZ SCB control NEO software	WS10012
KARL STORZ ENDOFLATOR 40	UI400
KARL STORZ ENDOFLATOR 50	UI500
HAMOU ENDOMAT	26331101-1
One-pedal Footswitch – HF Generators	UF901
Two-pedal Footswitch – HF Generators	UF902
Monopolar Cable	26002M 26002ML 26002MR 26004M 26004ML 26005M 26005ML 26006M 26006ML 277 277A 277KB 277KE 279 279KB 279KE
Bipolar Cable	26176LE 26176LEL 26176LER 26176LM 26176LML 26176LV 26176LVL 26176LW 847000E 847000M 847000V 847000W 847002V UH801

 To protect personnel, KARL STORZ recommends the use of the KARL STORZ S-PILOT (UP501) to extract electrosurgical smoke.

Neutral electrodes must comply with IEC 60601-2-2 and have a 2-pin US-style connection.

Observe the peak voltage output of applied parts.

HF cables that are 3 to 5 meters long can be connected to the product.

4.3 Technical data

AUTOCON III 400 General

Designation	Value
EMC	IEC 60601-1-2
Electrical protection class	I
Applied part type according to IEC 60601-1	CF
Operating mode	Intermittent 10/30 sec (on/off) The system switches off automatically after continuous activation lasting 45 sec
Max. monopolar power	400 W (at 200 Ω)
Max. bipolar power	400 W (at 75 Ω)
Output frequency	350 kHz/1 MHz
Dimensions (L x H x W)	457 x 177 x 447 mm
Weight	12.5 kg

AUTOCON III 400 Power input















Designation	Value	
	UH400E 220–240 V	UH400UE 100–127 V
Min. power input	3 W / 40 VA	3 W / 40 VA
Min. current consumption	200 mA	400 mA
Max. power consumption (at 400 W)	700 W / 1,150 VA	700 W / 1,150 VA
Max. current consumption (at 400 W)	5 A	10 A @100 V 8 A @127 V
Mains fuse	2 x T5 AH 250 V	2 x T10 AH 250 V
Operating voltage (AC)	198–264 V	90–139.7 V
Operating frequency	50/60 Hz	50/60 Hz



Footswitches

Designation	Value	
	UF901	UF902
Voltage (U_B)	Max. 25 V AC / 60 V DC	Max. 25 V AC / 60 V DC
Current (I_B)	Max. 1 A	Max. 1 A
Power (P_B)	Max. 20 W	Max. 20 W
Degree of protection acc. to IEC 60529	IPX8	IPX8
Dimensions (L x H x W)	187 x 35 x 177 mm	190 x 64 x 346 mm
Weight	1.66 kg	2.05 kg











4.4 Symbols employed



4.4.1 Symbols on the packaging

Symbol	Meaning
	Manufacturer
	Date of manufacture
	Medical device
	Article no.
	Serial number
	Number of products in the product packaging
	Unique Device Identifier
	Consult the printed or electronic instructions for use
	Fragile, handle with care
	Keep dry
	Temperature limit
	Humidity limit
	Air pressure limit
	Transport conditions
	In one combined field surrounded by a border with the “conditions for transport” symbol: Temperature limit for transport









Symbol	Meaning
	In one combined field surrounded by a border with the “conditions for transport” symbol: Humidity, limit for transport
	Federal (USA) law restricts this device to sale by or on the order of a physician.
	CE marking With this marking, the manufacturer declares the conformity of the product with the applicable EU regulations. A code number after the CE mark indicates the responsible notified body. The EU regulations relevant to the product can be found in the EU Declaration of Conformity, which can be requested from KARL STORZ.

4.4.2 Symbols on the product

Symbol	Meaning
	Follow the instructions for use. The color may differ on the product. The symbol is black/white on the packaging label.
	Connection socket, e.g., for footswitch
	Neutral electrode isolated from ground for HF
	Applied part type CF defibrillation protection
	Ready/standby button
	Labeling of the (active) HF output; Caution: Hazardous voltage.
	Potential equalization connector
	Signal input for fiber-optic connection
	Signal output for fiber-optic connection
	Ethernet

Symbol	Meaning
	USB port
	S-PILOT connector (surgical smoke extraction)
	UART communication interface for service purposes

4.4.3 Symbols on the type plate

Symbol	Meaning
	Manufacturer
	Date of manufacture
	Article no.
	Serial number
	CE marking With this marking, the manufacturer declares the conformity of the product with the applicable EU regulations. A code number after the CE mark indicates the responsible notified body. The EU regulations relevant to the product can be found in the EU Declaration of Conformity, which can be requested from KARL STORZ.
	Consult the printed or electronic instructions for use
	Dangerous voltage Danger of an electric shock!
	During activation (of the HF device) HF energy in the radio frequency range 9 kHz to 400 GHz is applied, which produces electromagnetic radiation.
	Separate collection of electrical and electronic devices. Do not dispose of in household refuse.

4.5 Ambient conditions

For UH400E, UH400UE

Storage and transport conditions	
Temperature	-20°C ... +60°C (-4°F ... +140°F)
Relative humidity (non-condensing)	0–90%
Air pressure	500–1,060 hPa
Operating conditions	
Temperature	10°C ... 40°C (50°F ... 104°F)
Relative humidity (non-condensing)	30–75%
Air pressure	700–1,060 hPa
Max. operating altitude	3,000 m

For UF901, UF902

Storage conditions	
Temperature	-10°C ... +60°C (14°F ... 140°F)
Relative humidity (non-condensing)	5–95%
Air pressure	500–1,080 hPa
Transport conditions	
Temperature	-29 °C ... +50 °C (-20 °F ... +122 °F)
Relative humidity (non-condensing)	5 – 85 %
Operating conditions	
Temperature	-10°C ... +60°C (14°F ... 140°F)
Relative humidity (non-condensing)	10–100%
Air pressure	800–1,060 hPa

5 Preparation

5.1 Unpacking the product

1. Carefully remove the product and accessories from the packaging.
2. Check the delivery for missing items and possible damage.
3. In the case of damage, hidden defects, and short deliveries, document their nature and extent and contact the manufacturer or supplier immediately.
4. Keep packaging for further transport.

5.2 Reprocessing the product

- ▶ Reprocess the product in line with the reprocessing instructions before using it.

5.3 Setting up the product

▲ CAUTION**Breakable glass! Risk of injury!**

The glass of the screen will break if the product is dropped or sustains a significant impact. Patients, users or third parties can injure themselves on broken glass.

- ▷ Do not touch broken glass.
- ▷ Do not touch the glass parts of the product.
- ▷ Remove small glass parts from the product.
- ▷ Have the glass replaced by qualified service personnel.

NOTICE**Overheating! Product failure!**

Insufficient ventilation can cause an internal build-up of heat, resulting in a safety shut-down.

- ▷ Ensure adequate air circulation.
- ▷ Keep air inlets and outlets clear.

NOTICE**High-frequency electromagnetic fields! Image interference!**

HF devices generate high-frequency electromagnetic fields that can interfere with the operation of sensitive electronic equipment and, for example, lead to image interference.

- ▷ HF devices and their cables should never be installed close to any devices sensitive to electromagnetic interference.
- ▷ Parallel cable routing with cables from other devices should be avoided, as HF cables emit HF emissions when activated, which may interfere with other equipment.
- ▷ Connect the power connection of the product or the impaired device to another circuit.
- ▷ Increase the distance between the product and the impaired device.
- ▷ Lay the instrument cables so that they are not in the vicinity of other devices and their connecting cables.

- ① If the product was previously stored or transported at temperatures below +10°C or a non-condensing relative humidity above 75%, the device requires 3 hours to adjust to room temperature.

This product and connected components may only be used in medical rooms with electrical installations that conform to applicable national regulations.

1. Set the product down on a horizontal, flat surface or a video cart.

2. Always operate the product in the prescribed ambient conditions.
3. Install the product out of reach of patients. To do this, observe the minimum distances recommended by KARL STORZ:

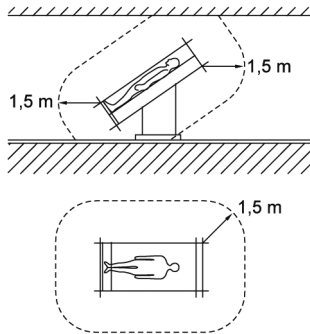

4. Position the product with the front panel facing the patient or surgeon.

5.4 Connecting the product

The resistance value between the central potential equalization of the operating room and the product connection and every other metallic touchable surface must not exceed 0.2 Ohm. If no potential bonding bar is used during installation, the connection to the PE conductor should be as low-resistance as possible.

Monitoring systems with protective resistors or HF chokes are recommended for limiting the high-frequency current. Needle electrodes for monitoring are not recommended.

1. Connect the potential equipotential cable.
2. Connect the power cord.
3. Attach monitoring electrodes and surgical electrodes so they are positioned far away from each other.
4. Ensure that leads from monitoring devices do not touch the patient's skin.
5. Keep the leads to the HF electrodes short and position them so that they do not touch the patient or other leads.

5.5 Switching on the product

i Do not use the product if the display elements are not working.

1. Turn on the product using the power switch on the back panel.
 - ⇒ The Standby button on the front panel light up permanently.
2. Press the Standby button.
 - ⇒ The product performs a self-test: All display and control elements light up.
3. Check that all display and control elements are functioning correctly.
 - ⇒ Once successfully inspected, the main screen appears and the product is ready for use.
 - ⇒ The parameters of the most recently selected program appear.
 - ⇒ An acoustic signal sounds.
4. Press the Standby button again to activate Standby mode.

5.6 Connecting monopolar instruments

1. Plug the neutral electrode cable into the socket for the neutral electrode and choose the suitable neutral electrode type, see chapter *Selecting the neutral electrode* [p. 42].
 - ⇒ The socket illumination goes dark.
 - ⇒ The color of the neutral electrode button will change from gray to the measurement color green, yellow, or red.
2. Connect the electrode handle to a monopolar connection socket.
3. Connect the monopolar connecting cable to a monopolar connection socket.
4. Connect the footswitch if an accessory has no finger button.

5.7 Connecting bipolar instruments

1. Connect the bipolar cable to the instrument.
2. Connect the bipolar cable to a bipolar connection socket.
3. For bipolar use without AUTOSTART, connect the footswitch.
4. Alternatively, select a mode with AUTOSTART function at the corresponding socket.
 - ⇒ Once the instrument is connected, the application starts after the configured reaction time.
5. Deactivate the AUTOSTART function when bipolar instruments are inserted through a metallic trocar.

5.8 Connecting the footswitch

- ▶ During the operation, only the desired footswitch should be connected to one of the two connection sockets.
 - ⇒ The product automatically detects the connected footswitch.
 - ⇒ The connection socket used is displayed on the front panel of the product.

5.9 Checking the functions

The product automatically performs cyclical testing during operation. If any errors occur, see chapter *Errors and messages* [p. 67].

1. Connect the neutral electrode and attach it securely to the patient's arm.
 - ⇒ EASY monitoring appears green.
2. Connect a monopolar HF handle to a monopolar socket.
3. Use the manual switch and footswitch to individually activate the 'Cut' and 'Coag' functions.
4. Check the settings on the display.
5. Now change to the bipolar output and connect bipolar forceps.
6. Select a mode with AUTOSTART.
7. Grasp moist gauze with the forceps and check the display.
8. Select a mode without AUTOSTART.
9. Use the footswitch to activate the bipolar output.
10. Check the settings and display.
11. Remove the neutral electrode and dispose of it properly.
 - ⇒ EASY monitoring appears red and signals ring out.

5.10 Neutral electrode monitoring

Monitoring of the neutral electrodes prevents an undesired increase in the output voltage and thus minimizes the risk of burns at the site where the neutral electrode is attached.

Two types of neutral electrodes can be monitored:

- Small split neutral electrodes (for use with reduced power), see baby or children's electrodes
 - Split neutral electrodes
1. To set the type and contact quality of the neutral electrode, see chapter *Selecting the neutral electrode* [p. 42].
 2. For errors related to attaching the neutral electrode, see chapter *Errors and messages* [p. 67].

5.10.1 EASY monitoring

The EASY monitoring function measures changes in the resistance between the patient and the product before and during HF activation. This monitoring requires the use of a split neutral electrode with appropriate contact areas and suitable transition resistance. In this case, partial currents in the individual contact surfaces of the neutral electrode are not measured. Messages pop up and alarms ring out, during which the error display changes from green to yellow to red.

1. To attach the split neutral electrode correctly to the patient, see chapter *Using the neutral electrode* [p. 29].
2. Limit the minimum area of the neutral electrode to 90 cm² for the monopolar modes *Resection* and *Soft Contact*.

6 Application

6.1 Notes on use

⚠ WARNING**Unintentional activation! Risk of injury!**

In AUTOSTART mode, coagulation can be initiated inadvertently. This may harm the patient.

- ▷ Only activate the product when it is in your field of vision.
- ▷ Only activate the product if you can deactivate it immediately at all times.
- ▷ If the product is activated inadvertently, switch it off immediately using the Standby button.
- ▷ Be careful when using a footswitch or manual switch.
- ▷ Deactivate the AUTOSTART function when bipolar instruments are inserted through a metallic entry system.

⚠ WARNING**Product failure due to increased output power! Risk of injury!**

Failure of the product or accessories may cause the output power to increase unintentionally. This may result in injury to the patient.

- ▷ Check the product and its accessories prior to use.
 - ▷ Do not continue to use damaged products or accessories.
 - ▷ Have a replacement product and replacement accessories ready.
- ⓘ Low power output or improper function of the product under normal operating settings may indicate that the neutral electrode is not attached correctly or contact with the connectors is poor.
- ⓘ To prevent nerve and muscle stimulation from low-frequency currents, the power output and effect must be set as low as possible.
- ⓘ The bipolar technique must be used to prevent tissue damage during procedures on body parts with small cross sections and in areas with high resistance (bones or joints).

6.2 Using the accessories

1. Never place active electrodes on or near the patient.
2. Ensure that unused active electrodes do not touch the patient, medical staff, or flammable materials.
3. Ensure that the electrodes do not come into direct or indirect contact with the patient through electrically conductive objects.
4. Place the instruments in a safe place: sterile, dry, non-conductive, clearly visible.
5. Do not remove hot electrodes from the patient's body directly after cutting or coagulation.
6. Ensure there is sufficient distance between the cables of monitoring devices and the product cables.
7. Never run the patient cables across the patient.

6.3 Using the neutral electrode

⚠ WARNING

Heating up of the neutral electrode! Risk of burns!

If the neutral electrode is not attached correctly, it may heat up and injure the patient.

- ▷ In the case of self-adhesive disposable electrodes, follow the manufacturer's instructions regarding the point of application.
- ▷ Select the application point for the neutral electrode so that the current paths between the active and neutral electrodes are as short as possible and run longitudinally or diagonally to the patient's body, as muscles are more conductive in the direction of the fibrils.
- ▷ Depending on the surgical field, apply the neutral electrode to the nearest upper arm or thigh, but never closer than 20 cm.
- ▷ Ensure that the application area is free of scar tissue, bony protuberances, surface hair, and ECG electrodes.
- ▷ Avoid application areas where fluids may collect.
- ▷ For surgery in the thoracic region, do not run the current path transversely across the patient's body and ensure that the patient's heart is never in the current path.
- ▷ Ensure that there are no implants in the current path, e.g., bone nails, bone plates, or endoprostheses.
- ▷ Ensure that no short-circuits can occur at the neutral electrode connection.
- ▷ Use split neutral electrodes with a sufficiently large surface area. Always consider the patient's age and max. output power during operation.
- ▷ Check that the neutral electrode is working properly before selecting a mode or a higher power setting.

In the monopolar HF method, the neutral electrode feeds the current introduced into the patient's body at the surgical site back to the HF device.

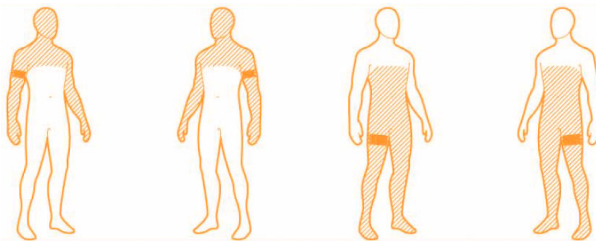

Application point for neutral electrode

1. Remove excess body hair.
2. Clean the application site, but do not use any alcohol, since it dries out the skin and increases the transition resistance.
3. If the patient has poor circulation, massage or brush the application site.
4. Attach the neutral electrode over the entire contact surface evenly.
5. Secure reusable neutral electrodes with rubber bands or elastic straps so they do not loosen when the patient moves. Ensure that the patient's circulation is not impaired (risk of necrosis).
6. Apply the split neutral electrode without any additional objects, otherwise the product will not recognize the bridging of the split surfaces.
7. Ensure that the HF current flows equally to both parts of the split neutral electrode.
8. Do not use wet cloths or conductive pastes.
9. Ensure that no liquids, such as irrigation fluids, disinfectants, blood, or urine, penetrate between the patient and the neutral electrode.
10. Do not place the neutral electrode under the patient's buttocks or back.

11. Ensure that there are no ECG electrodes in the current path of the HF device.
12. Check that the neutral electrode is working properly.
13. For neutral electrode monitoring, see chapter *EASY monitoring* [p. 27].

6.3.1 Using the disposable electrode

1. Remove the protective film and attach the self-adhesive disposable electrode to the skin firmly using both hands.
2. Ensure that the long edge of the disposable electrode faces the operation site and the electrode is fully in contact with the skin to avoid an increase in current density at the short edge.
3. Clamp the electrode tab to the electrode cable.
4. After the operation, remove the disposable electrode carefully to avoid skin damage.
5. Discard the disposable electrode correctly.

6.4 Main screen

The main screen consists of the following sections:



1 Status bar

2 Socket settings

Status bar

The following functions appear in the status bar:

- Favorites
- EASY monitoring (neutral electrode monitoring)
- Key lock
- Information
- Menu

Socket settings

The following settings can be specified for monopolar and bipolar connection sockets:

Setting	Description
Effect	Effect of electrosurgical cutting or coagulation
Pedal	Footswitch
Mode	Current type
Max. Watt	Maximum power output

6.5 Unlocking the screen

The screen is locked automatically.

1. Tap any control to unlock the screen.
⇒ A slider appears:

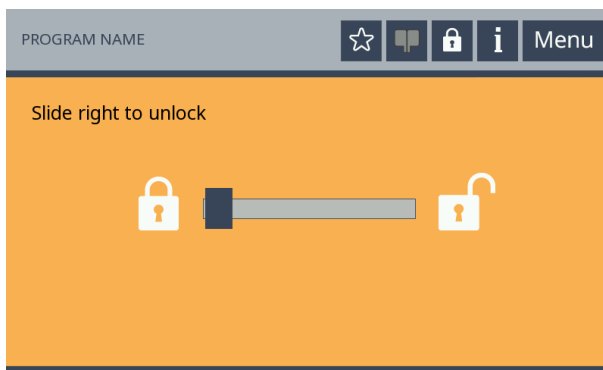

2. Drag the slider from the left to the right.
⇒ An open lock appears in the status bar.
3. To deactivate the screen lock or to change the automatic screen lock time, see chapter *Setting the screen lock* [p. 52].

6.6 Switching sockets on and off

1. To switch on sockets, plug a connecting cable into the connection socket.
2. Alternatively, tap the **Switch on socket** button on the main screen.
⇒ The socket settings appear.
⇒ When no instrument is connected, the socket settings are grayed out:

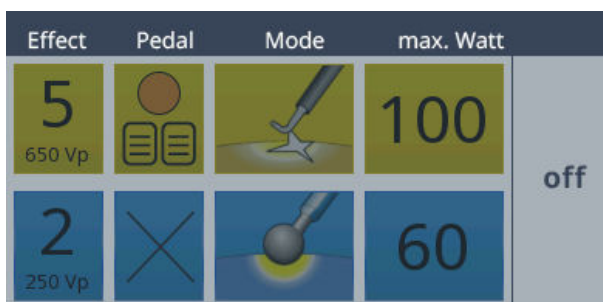

- Connect the instrument to the socket.
⇒ The socket settings are activated:

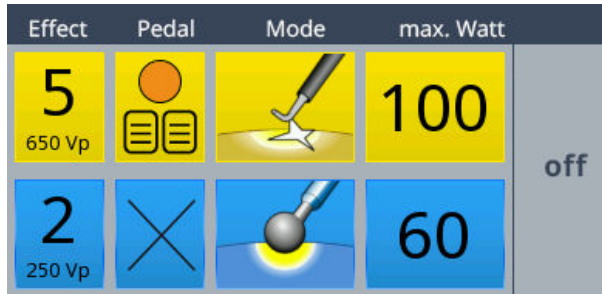

- Tap the **off** button to turn the socket off.

6.7 Setting the sockets

- All selection windows are closed after 30 seconds without adopting the modification.
- When a drop-down menu is open, all control elements outside the menu are inactive and cannot be activated.

6.7.1 Selecting the mode

How to set the current type is explained below using the example of monopolar cutting.

- ✓ A monopolar connection socket is turned on.
- ✓ An instrument is connected.



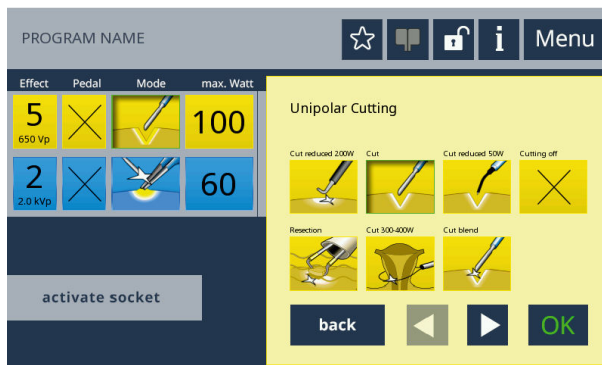



- Tap the yellow **Mode** button.
⇒ The selection of current types available appears. The current type in use at that time is highlighted and the border flashes.







- Select the desired current type.
- Tap the **Cutting Off** button to deactivate the mode.
- Browse using the **arrows** to bring up other options.
- Confirm the selection by tapping **OK**.
⇒ The main screen appears.
- Tap the **back** button to return to the main screen without making any changes.
 When the mode for a socket is adjusted, the settings for the other functions, such as **Effect** and **max. Watt**, remain unchanged.

6.7.1.1 Monopolar modes

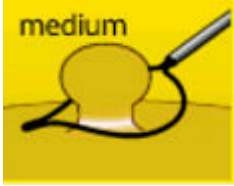
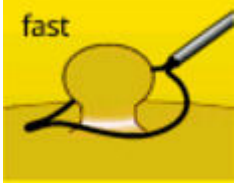
Monopolar cutting modes

Symbol	Designation
	Cut reduced 200 W
	Cut
	Cut reduced 50 W
	Resection
	Cut 300–400 W
	Cut blend
	Intermittent 400 W 1







Symbol	Designation
	Intermittent 400 W 2
	Intermittent 400 W 3
	Intermittent 300 W 1
	Intermittent 300 W 2
	Intermittent 300 W 3

Monopolar coagulation modes



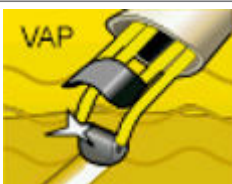

Symbol	Designation
	Forced Coag 1.8 kVp
	Soft contact
	Forced Coag
	Resection
	Spray
	Forced mixed
	Forced Coag with Cut



6.7.1.2 Bipolar modes

Bipolar cutting modes

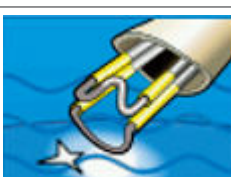
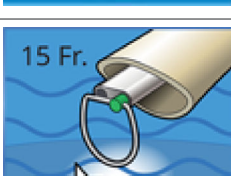
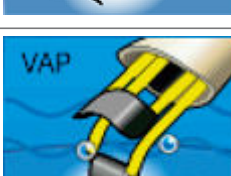
Symbol	Designation
	Bipolar cutting
	Bipolar scissors
	Bipolar resection
	Bipolar resection 15 Fr.
	Bipolar vaporization
	VAP CUT

Bipolar coagulation modes

Symbol	Designation
 The symbol shows a pair of forceps with a blue light emanating from the tip. The text "RoBi" is written in blue above the forceps.	RoBi
 The symbol shows a pair of forceps with a blue light emanating from the tip.	Standard plus
 The symbol shows two parallel forceps tips with a blue light emanating from the point where they meet.	Standard
 The symbol shows a bipolar resection forceps with a blue light emanating from the tip. A white starburst is shown at the point of contact.	Bipolar resection
 The symbol shows a bipolar resection forceps with a blue light emanating from the tip. A white starburst is shown at the point of contact. The text "15 Fr." is written in blue above the forceps.	Bipolar resection 15 Fr.
 The symbol shows a bipolar vaporization forceps with a blue light emanating from the tip. The text "VAP" is written in blue above the forceps.	Bipolar vaporization
 The symbol shows two parallel forceps tips with a blue light emanating from the point where they meet. A circular logo with a stylized 'S' is in the bottom right corner. The text "AUTO" is written in blue above the forceps.	Standard AUTO

Symbol	Designation
	VAP COAG
	Bipolar scissors
	Micro
	Forced

6.7.2 Setting the power output

How to set the power output is explained below using the example of monopolar cutting.

- ✓ The neutral electrode is attached properly.
- ✓ The working electrodes are clean.
- ✓ The plug connections are correct.
- ✓ A monopolar connection socket is turned on.
- ✓ An instrument is connected.

1. Tap the yellow **max. Watt** button.

⇒ The drop-down menu appears:

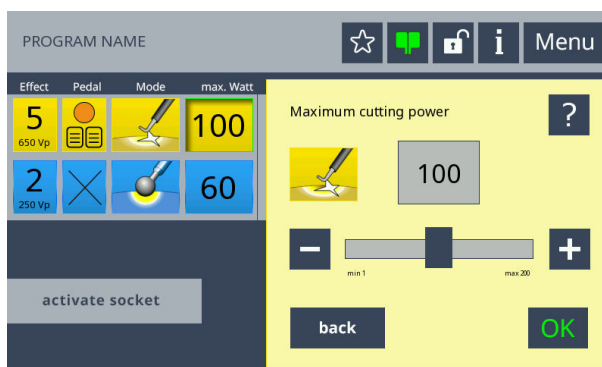

2. Tap the **Plus** and **Minus** buttons to set the maximum power output.
3. Alternatively, use the slider to set the power output in steps of ten.
4. Tap the **?** button for more information.
5. Confirm the setting by tapping **OK**.
 - ⇒ The main screen appears.
6. Tap the **back** button to return to the main screen without making any changes.

6.7.3 Selecting the effect

How to set the effect is explained below using the example of monopolar cutting.

- ✓ A monopolar connection socket is turned on.
 - ✓ An instrument is connected.
1. Tap the yellow **Effect** button.

⇒ The drop-down menu appears:

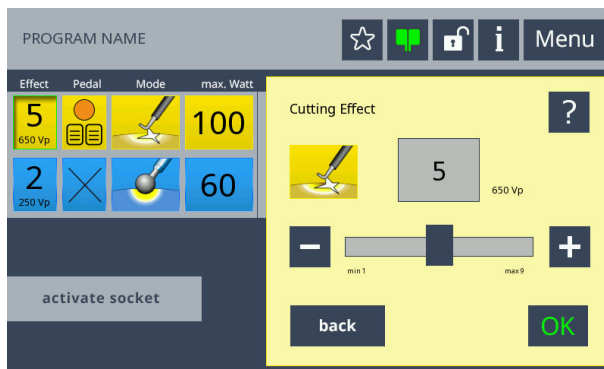

2. Tap the **Plus** and **Minus** buttons to set the cutting effect.
3. Alternatively, use the slider to set the effect in steps of ten.
4. Tap the **?** button for more information.
5. Confirm the setting by tapping **OK**.
 - ⇒ The main screen appears.
6. Tap the **back** button to return to the main screen without making any changes.

6.7.4 Assigning the footswitch

- ⓘ Handles and instruments with manual switches can be activated without preselecting a setting.

The one-pedal footswitch and the two-pedal footswitch can be connected using a changeover switch. The changeover switch enables switching between pedal levels.

1. Tap the **Pedal** button.
⇒ The drop-down menu appears:

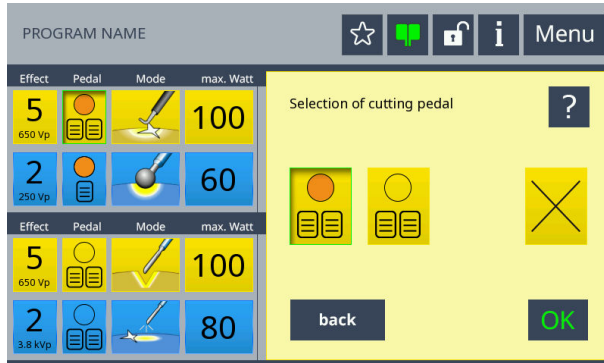







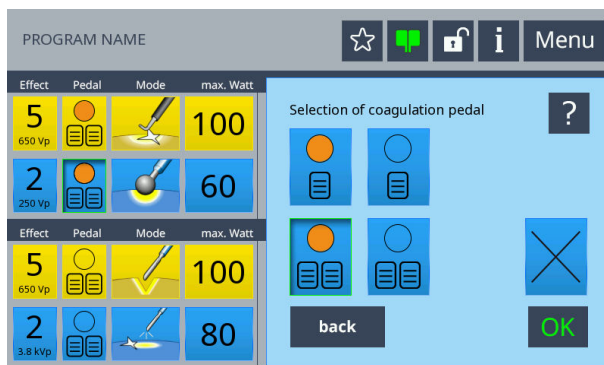

2. Tap the desired footswitch to assign the footswitch for the active pedal level, e.g., for cutting.
⇒ The border of the selected button will light up green.
3. Tap the **X** button to deactivate the footswitch.
4. Confirm the selection by tapping **OK**.
⇒ The socket is now assigned to the active pedal level.
⇒ The main screen appears.
5. Press the changeover switch on the footswitch to change the pedal level.
⇒ The socket is switched and the changeover switch on the **Pedal** button appears orange.





If two footswitches are connected, either a one-pedal footswitch or a two-pedal footswitch can be selected for coagulation.





The following footswitch types can be selected:

Symbol	Description
	Two-pedal footswitch CUT active
	Two-pedal footswitch CUT inactive
	Two-pedal footswitch not connected
	Deactivate footswitch CUT
	Two-pedal footswitch COAG active
	Two-pedal footswitch COAG inactive
	Two-pedal footswitch not connected
	One-pedal footswitch COAG active

Symbol	Description
	One-pedal footswitch COAG inactive
	One-pedal footswitch not connected
	Deactivate footswitch coagulation

6.7.5 Selecting the neutral electrode

-  The maximum output power of monopolar current types is reduced to 50 W when small electrodes are selected, see baby or children's electrodes.
-  No unsplit electrodes are accepted when using the *EASY* and *BABY 50 W* mode. No split electrodes are accepted when using the *MONO* mode.





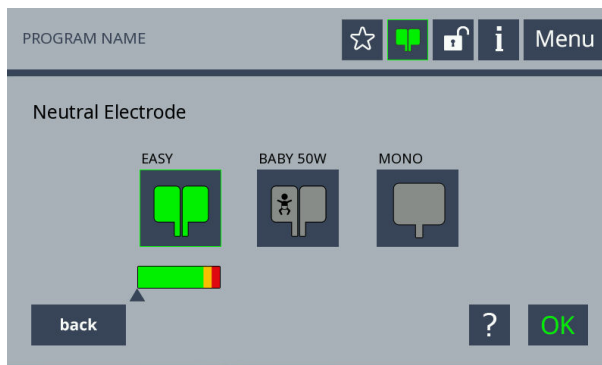

1. Tap the **EASY** button in the status bar.





⇒ The selection of neutral electrodes with a display for the contact quality appears:



2. Tap one of the following buttons to select the connected neutral electrode:
 - EASY: split neutral electrode monitoring
 - BABY 50 W: small split neutral electrode monitoring
 - MONO: unsplit neutral electrodes
3. Always select the largest possible electrode when attaching a neutral electrode.
4. Tap the **?** button for more information.
5. Confirm the selection by tapping **OK**.
 - ⇒ The main screen appears.
6. Tap the **back** button to return to the main screen without making any changes.

⇒ The selected type of neutral electrode with a color display for the contact quality appears in the status bar:

Symbol	Description
	Split neutral electrode Contact quality OK
	Split neutral electrode Contact quality not optimum
	Split neutral electrode Contact quality insufficient
	Split neutral electrode not connected
	Small split neutral electrode Contact quality OK
	Small split neutral electrode Contact quality not optimum
	Small split neutral electrode Contact quality insufficient

Symbol	Description
	Small split neutral electrode not connected
	Unsplit neutral electrode Contact quality OK
	Unsplit neutral electrode Not detected or contact quality insufficient
	Unsplit neutral electrode not connected

6.7.6 Coding system

The coding system enables automatic instrument identification. The coding system recognizes the connected coded KARL STORZ instrument and automatically selects the preferred parameters. If the socket already has preset parameters, a plausibility check is performed. The values of the coded instrument are accepted if the values are within a permissible limit.

1. Insert the coded instrument into a socket on the product.

⇒ The instrument data is read.

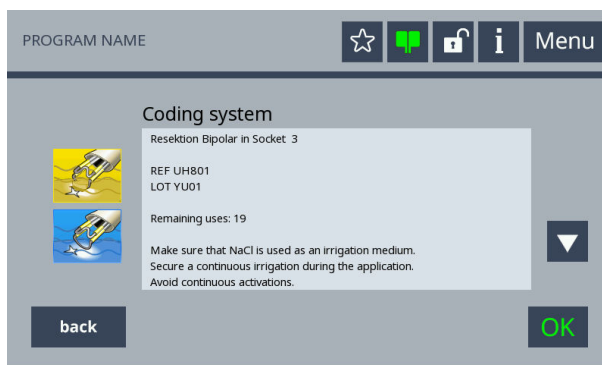

- ⇒ The description of the instrument appears:
- Instrument name
 - Socket detected

- Item number
 - Batch number
 - Remaining uses
- ⇒ The parameters are transferred automatically after 5 seconds and appear in the main screen.
- ⇒ The coded instrument can be used with the preset parameters.
- ⇒ The permissible parameters of the coded instrument can be activated, all other modes are grayed out.
2. Alternatively, tap the **OK** button to apply the settings.
 3. Tap the **back** button to return to the main screen without making any changes.

6.8 Menu

Use the menu to adjust settings such as the language, the sound, or display and storage options.

1. Tap the **Menu** button in the status bar.
 - ⇒ The **Menu** appears:

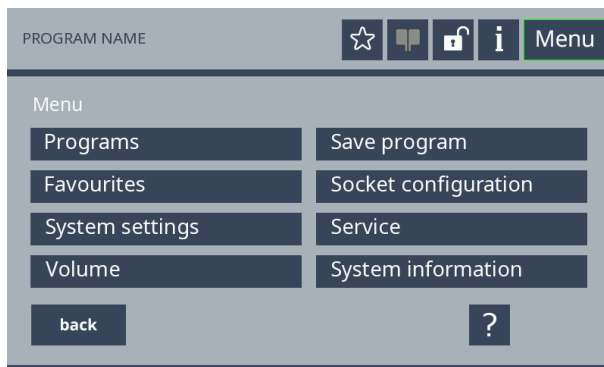

2. Tap the **back** button to return to the main screen.

6.8.1 Programs

Programs can be loaded, deleted, and added to favorites in the **Programs** menu.

1. Tap the **Programs** button in the **Menu**.
 - ⇒ The **Program list** appears:

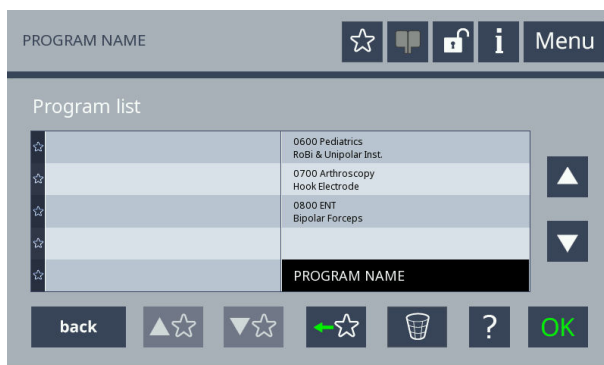

2. Alternatively, tap the program name in the status bar to open the program list.
3. Tap the **back** button to return to the **Menu**.

6.8.1.1 Loading and deleting programs

1. Tap on a program on the right side of the **Program list**.
⇒ The program name is highlighted in black.



2. Load the selected program by tapping **OK**.
3. Tap the **Trash can** button to delete the program.
4. Confirm the prompt.
⇒ The program is deleted.
5. Browse the **Program list** using the **arrows** . The program names are sorted alphabetically.

6.8.1.2 Adding programs to favorites

Up to 200 favorites can be created.

1. Tap on a program on the right side of the **Program list**.
⇒ The program name is highlighted in black.



2. To add the program to favorites, tap the **Add to favorites** button.
⇒ The program name appears on the left of the favorites list.

3. Tap the program name to remove a program from the favorites list.
⇒ The program name is highlighted in black.



4. Tap the **Remove favorites** button.
⇒ The program is removed from the favorites list.
5. Sort the favorites list with the buttons.

6.8.2 Saving a program

In the **Save program** menu, the current setting can be saved under different program names. The function is enabled by default.

1. Tap the **Save program** button in the **Menu**.
⇒ A keyboard appears:



2. Enter a program name using the keyboard and confirm by tapping **OK**.
⇒ The name appears in the program list.
3. Tap the **back** button to return to the **Menu**.

6.8.3 Favorites

You can select programs that have been added to the Favorites list in the **Favorites** menu.

1. Tap the **Favorites** button in the **Menu**.
⇒ The favorites list appears.
2. Alternatively, tap the **Star** button in the status bar to bring up the favorites list.
3. Browse using the **arrows** .

4. Select a favorite and confirm by tapping **OK**.
5. Tap the **back** button to return to the **Menu**.

6.8.4 Socket configuration

Socket settings can be adjusted in the **Socket configuration** menu.

1. Tap the **Socket configuration** button in the **Menu**.
⇒ The **Socket configuration** menu appears:

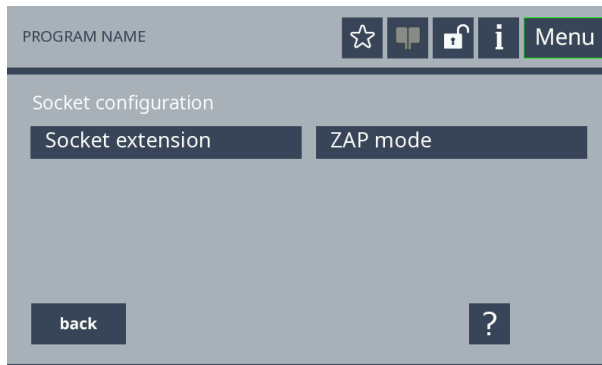



2. Tap the **back** button to return to the **Menu**.

6.8.4.1 Expanding sockets

The bottom bipolar connection socket can be split into two sockets in the **Expand socket** menu.

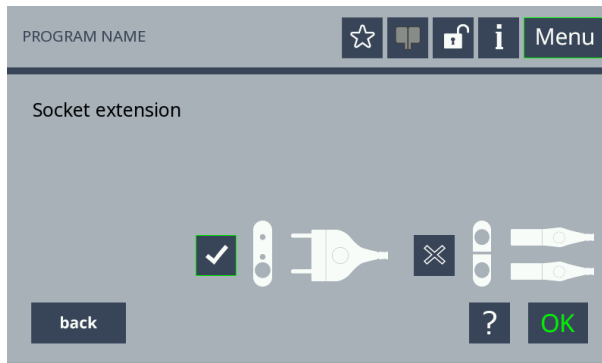
1. Tap the **Expand socket** button in the **Socket configuration** menu.
⇒ The **Expand socket** menu appears:



2. Tap the button  next to the two connectors to split the connection socket into two sockets.
⇒ The  button appears.
3. Confirm the setting by tapping **OK**.
⇒ The bottom bipolar connection socket is split into two sockets.
4. Tap the **back** button to return to the **Socket configuration** menu.

6.8.4.2 ZAP mode

The ZAP mode lets you switch between two preset current types for the same instrument.

1. Tap the **ZAP mode** button in the **Socket configuration** menu.
⇒ The **ZAP Mode** menu appears:



2. Tap the buttons next to the sockets to activate or deactivate the ZAP mode.
3. Confirm the selection by tapping **OK**.
⇒ The **ZAP mode** button with two levels appears in the main screen next to the socket settings.

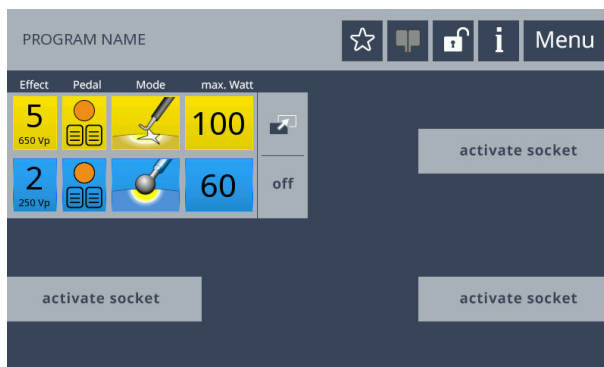

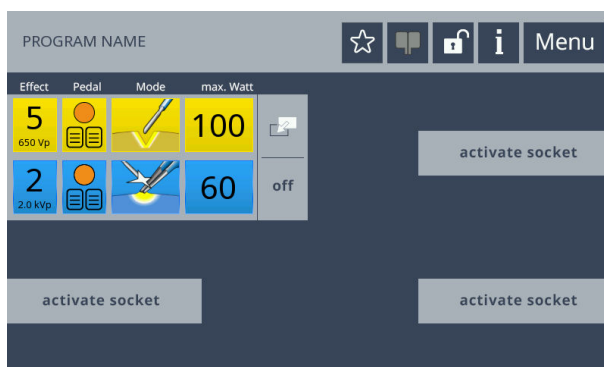

4. Tap the **ZAP mode** button to change the level manually.
⇒ The level is changed. The level symbol on the button appears white and the arrow changes direction.

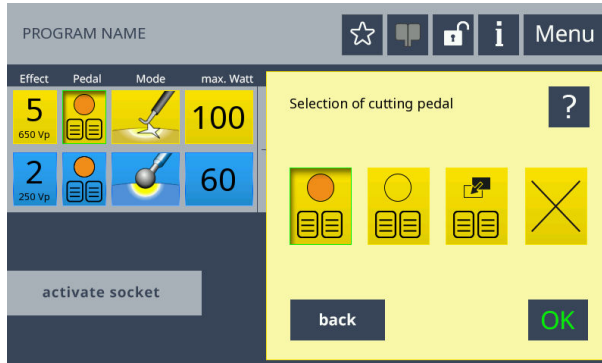

5. Alternatively, press the two buttons on the handle to change levels.

- Tap the **Pedal** button in the main screen to change the levels with the footswitch.
⇒ The drop-down menu appears:



- Tap the **ZAP mode footswitch**  button and confirm by tapping **OK**.
⇒ The **ZAP mode footswitch** button appears on the main screen.

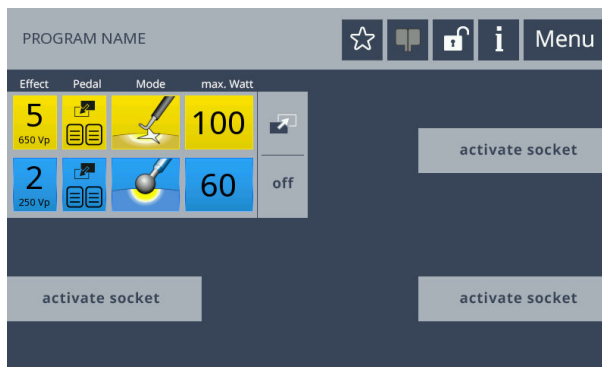

- Press the changeover switch on the footswitch to change levels.

6.8.5 System settings

- Tap the **System settings** button in the **Menu**.
⇒ The **System settings** menu appears:

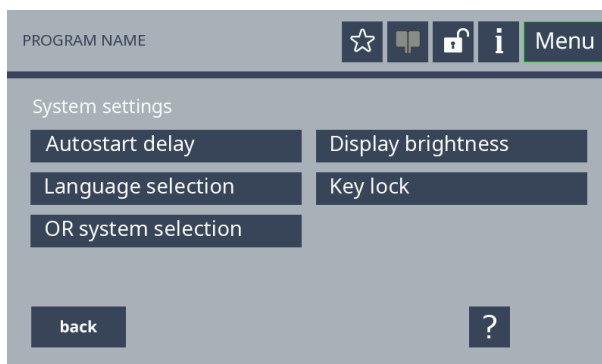

- Tap the **back** button to return to the **Menu**.

6.8.5.1 Autostart delay

Under Autostart delay, the time can be set after which the HF generator is automatically activated when contact is made with the tissue depending on the impedance.

1. Tap the **Autostart delay** button in the **System settings** menu.

⇒ The **Autostart delay** menu appears:

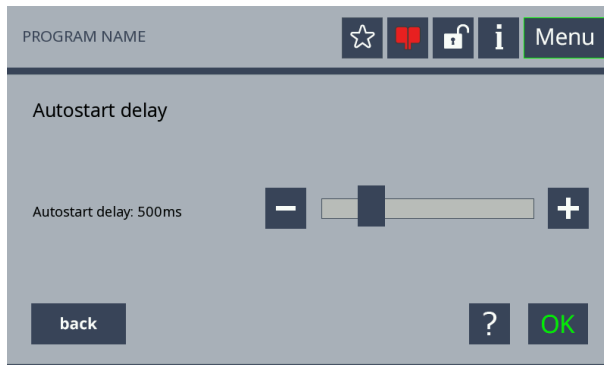

2. Tap the **Plus** and **Minus** buttons to set the **Autostart delay**.
3. Alternatively, use the slider to set the **Autostart delay**.
4. Confirm the setting by tapping **OK**.
 - ⇒ The **System settings** menu appears.
5. Tap the **back** button to return to the **System settings** menu without making any changes.

6.8.5.2 Selecting a language

1. Tap the **Language selection** button in the **System settings** menu.
2. Select the desired language and confirm by tapping **OK**.
 - ⇒ The **System settings** menu appears.
3. Tap the **back** button to return to the **System settings** menu without making any changes.

6.8.5.3 OR system selection

The connection to the KARL STORZ OR system OR1 can be created under the menu **OR system selection**. Upon delivery the KARL STORZ OR system OR1 is in Standby mode.

This is indicated in the status bar by the following symbol:



To establish a connection to the OR1 OR system, a LAN cable specified by KARL STORZ must be used. Further information can be requested from Service. When the cable is connected, a connection to the OR1 OR system is automatically established.

1. Press the **OR system selection** button in the **System settings** menu.
⇒ The **OR system selection** menu appears:

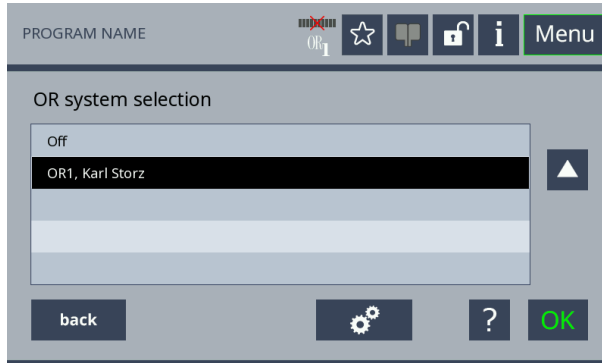

2. Tap the menu item **Off** and confirm by tapping **OK** to deactivate the connection to the OR1 OP system.
⇒ The OR1 symbol in the status bar is hidden. Automatic connection to the OR1 OR system is no longer possible.
3. To restore Standby mode, tap the menu item **OR1, Karl Storz** and confirm by tapping **OK**.
⇒ The following symbol appears in the status bar:



4. Tap the **Settings**  button to configure network settings. Ensure the configurations are adjusted by trained service personnel.

6.8.5.4 Setting the display brightness

1. Tap the **Display brightness** button in the **System settings** menu.
2. Set the brightness and confirm by tapping **OK**.
⇒ The **System settings** menu appears.
3. Tap the **back** button to return to the **System settings** menu without making any changes.

6.8.5.5 Setting the screen lock

1. Tap the **Key lock** button in the **System settings** menu.
2. Set a time between 30 seconds and 5 minutes after which the automatic screen lock is activated, or deactivate the screen lock feature.
3. Confirm the setting by tapping **OK**.
⇒ The **System settings** menu appears.
4. Tap the **back** button to return to the **System settings** menu without making any changes.

6.8.6 Service

Service contact data is stored in the **Service** menu. Other settings can be specified via a password-protected section.

1. Tap the **Service** button in the **Menu**.
⇒ The Service contact information appears:

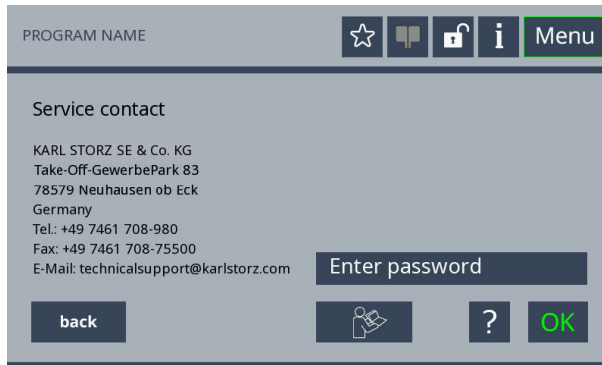

2. Tap the **Enter password** button and enter the following password: 001224.
⇒ The **Service tools** menu appears:

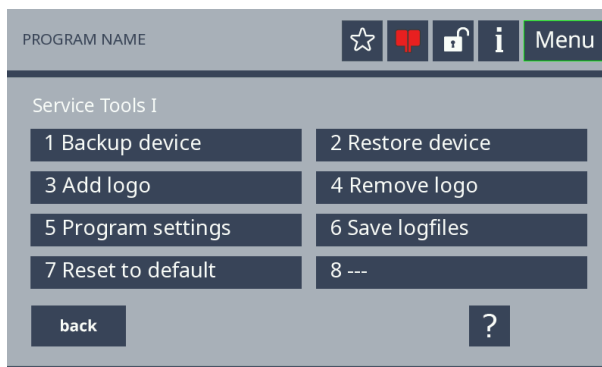

3. Tap the **Backup device** button to save settings to the KARL STORZ USB flash drive (20040282).
⇒ All programs and system settings are saved.
4. Press the **Restore device** button to transfer the settings saved on the KARL STORZ USB flash drive to the device.
5. Tap the **Add logo** button to save a custom logo for display at startup.
6. Tap the **Remove logo** button to delete a custom logo.
7. Tap the **Save logfiles** button to save all log files to the KARL STORZ USB flash drive.
8. Tap the **Reset to default** button to reset all settings to the default setting.

6.8.7 Adjusting the volume

The level of the acoustic signal of the active electrode must be set so that it is always clearly audible.

1. Tap the **Volume** button in the **Menu**.

⇒ The **Volume** menu appears:



2. Tap the **Plus** and **Minus** buttons to set the signal tones.
 3. Alternatively, use the sliders to set the signal tones.
 4. Confirm the settings by tapping **OK**.
⇒ The **System settings** menu appears.
 5. Press the **back** button to return to the **Menu** without making any changes.
- i** If required, the activation signals can be adjusted to remain effective in a louder environment. The alarm tones have a minimum volume and can only be changed to a limited extent.

Mode	Category	Frequency (Hz)	Signal type
Monopolar Cut	Activation tones	635	Continuous sound
Monopolar Coag	Activation tones	475	Continuous sound
Bipolar Cut	Activation tones	565	Continuous sound
Bipolar Coag	Activation tones	505	Continuous sound
Footswitch changeover	Activation tones	–	Signal tone
ZAP mode	Activation tones	–	Signal tone
Fault	Alarm tones	–	Signal tone
Warning	Alarm tones	–	Signal tone
Note	Alarm tones	–	Signal tone

6.8.8 System information

The **System information** menu displays various system parameters, such as the version, the serial number, the next date for the technical safety inspection (TSI).

1. Tap the **System information** button in the **Menu**.
⇒ The system information appears:

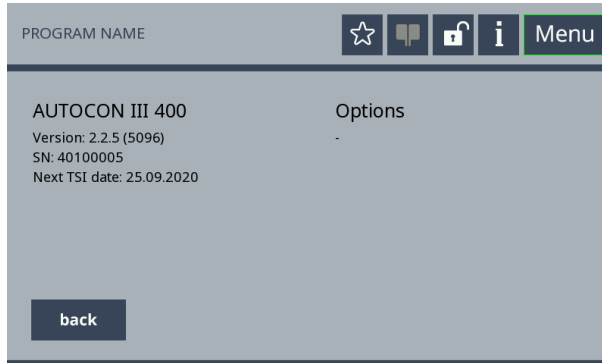

2. Tap the **back** button to return to the **Menu**.

6.9 System messages

System messages appear on the touch screen and are grouped into three categories (see chapter *System messages* [p. 67]):

- Notes (gray)
- Warnings (orange)
- Faults (red)

Notes are shown for 5 seconds, while warnings and faults are shown for 10 seconds. No settings can be changed until a fault is resolved. All system messages that have appeared since the product was switched on are saved. The memory is cleared when the product is switched off.

Do the following to view the system messages:

1. Tap the **i** button in the status bar.
⇒ The **System messages** appear:

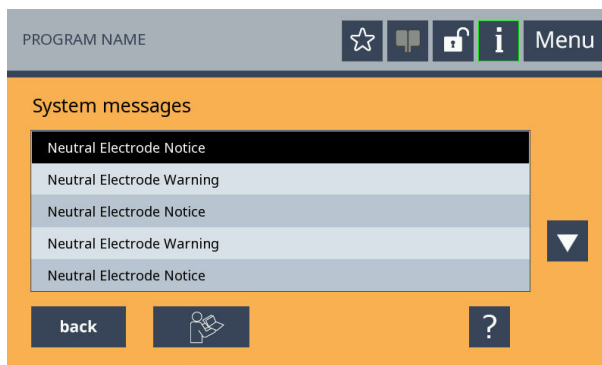

2. Tap a message.
⇒ The message is highlighted in black.
3. Tap the **Read message**  button to open the message.
4. Browse using the **arrow**.
5. Tap the **back** button to return to the main screen.

6.10 Switching off the product

1. Press the Standby button on the front panel of the product.
2. Switch off the power on the back panel of the product.
 - ⇒ The Standby button stays lit white for a few seconds.
 - ⇒ When the Standby button is no longer lit, the product is de-energized.
3. Remove connected accessories from the product and reprocess.

7 Maintenance, servicing, repairs, and disposal

7.1 Maintaining the product

If they are not described in more detail here, maintenance activities may only be performed by KARL STORZ or by a company authorized by KARL STORZ.

7.1.1 Maintenance

The following maintenance intervals are recommended:

Interval	Activity	To be performed by
annually	Safety test	KARL STORZ service technicians

7.2 Safety inspection in accordance with IEC 62353

⚠ WARNING

Risk of injury due to product degradation!

Patients, users and third parties may be injured as a result of product and accessory degradation.

- ▷ Shut down the product.
- ▷ Have the deficiencies repaired by persons authorized by KARL STORZ.

Regardless of the national accident prevention regulations and testing intervals for medical devices, for this device safety checks must be performed as repeat inspections according to IEC 62353 and recorded by a qualified electrician at least once a year. Detailed specifications regarding the scope and execution of the safety inspection can be found in the service manual.

7.2.1 Visual inspection

1. Check the product and accessories for any mechanical damage.
2. Check labels for readability.

7.2.2 Electric measurements

i Limit values for electrical measurements can be found in the current IEC 62353.

1. Measure the protective ground resistance.
2. Measure the earth leakage current.
3. Measure the touch current.
4. Measure the patient leakage current.

7.2.3 Functional test

1. Perform a functional test in line with the instructions for use.
2. Document the results of the safety inspection.

7.3 Repairs to the product

Repair work may only be performed by KARL STORZ or by a company authorized by KARL STORZ.

- ▶ Please contact your local KARL STORZ subsidiary or authorized dealer (see the list of subsidiaries).

Contaminated devices may not be shipped. To prevent contact infections and airborne infections, products must first be decontaminated. KARL STORZ reserves the right to send back contaminated products.

7.4 Disposing of the product

The product meets the requirements of the Directive on Waste Electrical and Electronic Equipment (WEEE).

Within the scope of application of this directive, KARL STORZ SE & Co. KG is responsible for the proper disposal of this product.

1. The product must be disposed of in accordance with the applicable national laws and regulations at a suitable collection point for the reprocessing of electrical and electronic equipment.
2. Contact KARL STORZ SE & Co. KG, a KARL STORZ branch or an authorized dealer to find out the address of the collection point in your area.

8 Accessories and spare parts

8.1 Accessories

For UH400E, UH400UE

Item	Order no.
Power cord, length 300 cm	400A
Power cord, US version, 200 cm	400B
Potential equipotential cable, 5 m	20010270
Potential equalization cable, 200 cm	20010370
Potential equalization cable, 150 cm	20010570
Potential equipotential cable, 1 m	20010670
One-pedal Footswitch – HF Generators	UF901
Two-pedal Footswitch – HF Generators	UF902
Connecting Cable for Flex. Argon Probes	UH570
HF Connecting Cable, 3.5 mm, 300 cm	UP004

Monopolar cables

Item	Order no.
Unipolar high frequency cable, 300 cm	277
Unipolar high frequency cable, 300 cm	277A
Unipolar high frequency cable, 300 cm	277KB
Unipolar High Frequency Cord, 300 cm	277KE
Unipolar high frequency cable, 300 cm	279
Unipolar High Frequency Cord, 300 cm	279KB
Unipolar High Frequency Cord, 300 cm	279KE
Unipolar high frequency cable, 300 cm	26002M
Unipolar high frequency cable, 500 cm	26002ML
Unipolar High Frequency Cable, 600 cm	26002MR
Unipolar high frequency cable, 300 cm	26004M
Unipolar high frequency cable, 500 cm	26004ML
Unipolar high frequency cable, 300 cm	26005M
Unipolar high frequency cable, 500 cm	26005ML
Unipolar high frequency cable, 300 cm	26006M
Unipolar high frequency cable, 300 cm	26006ML

Bipolar cables

Item	Order no.
Bipolar high frequency cable, 300 cm	26176LE
Bipolar high frequency cable, 500 cm	26176LEL
Bipolar High Frequency Cable, 600 cm	26176LER
Bipolar high frequency cable, 300 cm	26176LM
Bipolar high frequency cable, 500 cm	26176LML
Bipolar high frequency cable, 300 cm	26176LV
Bipolar high frequency cable, 500 cm	26176LVL
Bipolar high frequency cable, 300 cm	26176LW
Bipolar high frequency cable, 300 cm	847000E
Bipolar high frequency cable, 300 cm	847000M
Bipolar high frequency cable, 300 cm	847000V
Bipolar high frequency cable, 300 cm	847000W
Bipolar high frequency cable, 450 cm	847002V
Bipolar high frequency cable, 400 cm	UH801

8.2 Spare parts

For UH400E, UH400UE

Item	Order no.
FUSE/ASM/T5.0AH/5.0x20mm	1222890
FUSE/ASM/T10AH/5x20mm	1432095

9 Electromagnetic compatibility

9.1 General notes on the operating environment

The product is suitable for use in professional healthcare facility environment. Professional healthcare facility includes physician offices, dental offices, limited care facilities, freestanding surgical centers, freestanding birth centers, multiple treatment facilities, hospitals (emergency rooms, patient rooms, intensive care, surgical rooms, outside the RF shielded room of an ME system for MRT).

- ❗ The emission characteristics of this product make it suitable for use in industrial areas as well as in hospitals (CISPR 11 Class A) and other professional healthcare environments. If it is used in a residential environment (for which CISPR 11 Class B is normally required), the product may not offer sufficient protection for radio transmission operation. The user might need to take mitigation measures, such as relocating or re-orienting the product.

⚠ WARNING

Electromagnetic interferences! Malfunction!

Use of this product adjacent to or stacked with other equipment could result in improper operation.

- ▷ This situation should be avoided.
- ▷ If such use is necessary: Verify that this equipment and the other equipment are operating normally.

9.2 Key performance characteristics

⚠ WARNING

Reduced immunity or increased emissions! Malfunction!

Use of the product with accessories, transducers and cables other than those specified in this manual may result in increased emissions or decreased immunity.

- ▷ Only use the accessories specified in the manual.

⚠ WARNING

Degradation of performance! Malfunction!

Portable RF communications equipment (including peripherals such as antenna cables and external antennas) could result in degradation of the performance of the product.

- ▷ Use portable communications equipment no closer than 30 cm (12 inches) to any part of the product, including cables.

In accordance with IEC 60601-2-2, the key performance characteristics are covered in the requirements for basic safety as stated in IEC 60601-1 in the case of HF surgical devices. As part of the risk management process, the following additional key performance characteristics were identified:

- The accuracy of the maximum HF output voltage and the effect on patient tissue, which are summarized in the specific standard 60601-2-2.
- A stable neutral electrode monitoring system
- The minimum noise level of the activation indicator and the acoustic notification sounds

EMC ambient conditions that deviate from the interference levels stated in the tables below may impair the function of the key performance characteristics or cause them to fail completely. This may result in malfunctioning or failure of the neutral electrode monitoring system or the acoustic activation indicators and notification sounds. The accuracy of the HF power output may deviate by more than the permissible 20%.

9.3 Accessories, transducers, and cables

The following accessories and cables are defined for EMC compliance.

Type	Shielded	Maximum length	Contains ferrite	Use
Unipolar/Monopolar cable	No	5 m	No	Connects HF applied part to HF generator
Bipolar cable	No	5 m	No	Connects HF applied part to HF generator
Argon connecting cable and flexible probe	No	2.5 m + 3 m probe length	No	Connects HF applied part (flexible probe) to HF generator and argon beamer

9.4 Test-Tables

9.4.1 Table 1 – Compliance level for immunity tests

Guidelines and manufacturer's declaration – electromagnetic immunity

The product is intended for use in the electromagnetic environment specified below. The user of the product should make sure that it is used in such an environment.

Interference immunity tests	EN/IEC 60601 test level	Compliance level	Electromagnetic environment – guidelines
Electrostatic discharge (ESD) acc. to IEC 61000-4-2	± 8 kV contact discharge ± 15 kV air discharge	± 8 kV contact discharge ± 15 kV air discharge	Floors should be made of wood, concrete, or covered with ceramic tiles. If floors are covered with synthetic material, the relative humidity should be at least 30%.
Electrical fast transients/bursts acc. to IEC 61000-4-4	± 2 kV for power lines ± 1 kV for input and output lines 100 kHz repetition	± 2 kV for power lines ± 1 kV for input and output lines 100 kHz repetition	The power supply quality should be that of a typical commercial or hospital environment.
Surges acc. to IEC 61000-4-5	± 1 kV voltage outer conductor – outer conductor ± 2 kV voltage outer conductor – ground	± 1 kV voltage outer conductor – outer conductor ± 2 kV voltage outer conductor – ground	The power supply quality should be that of a typical commercial or hospital environment.
Voltage dips, short interruptions, and fluctuations of the power supply acc. to IEC 61000-4-11	<u>Voltage dip:</u> Dip to 0% for 1 cycle @ 0° phase angle Dip to 70% for 25/30 cycles @ 0° phase angle Dropout to 0% for 0.5 cycles @ 0°, 45°, 90°, 135°, 180°, 225°, 270°, and 315° phase angles <u>Voltage interruption:</u>	<u>Voltage dip:</u> Dip to 0% for 1 cycle @ 0° phase angle Dip to 70% for 25/30 cycles @ 0° phase angle Dropout to 0% for 0.5 cycles @ 0°, 45°, 90°, 135°, 180°, 225°, 270°, and 315° phase angles <u>Voltage interruption:</u>	The power supply quality should be that of a typical commercial or hospital environment. If the user of the product requires continued operation in the event of interruptions to the power supply network, it is recommended that the product be oper-

Interference immunity tests	EN/IEC 60601 test level	Compliance level	Electromagnetic environment – guidelines
	100% for 250/300 cycles	100% for 250/300 cycles	ated with an uninterruptible power supply or a battery.
Magnetic field at the supply frequency (50/60 Hz) acc. to IEC 61000-4-8	30 A/m at 50 Hz /60 Hz	30 A/m at 50 Hz /60 Hz	If image distortion occurs, it may be necessary to position the product further from sources of electromagnetic fields or to install magnetic shielding. Before the product is installed, the electromagnetic field should be measured to ensure that it is sufficiently low.
Immunity test acc. to IEC 61000-4-3 for high-frequency electromagnetic fields	3 V _{rms} 80 MHz to 2.7 GHz * Refer to Table 2 for wireless proximity HF field test levels	3 V _{rms} 80 MHz to 2.7 GHz	
Immunity to conducted disturbances, induced by high-frequency fields according to IEC 61000-4-6	3 V _{rms} on 150 kHz to 80 MHz 1 kHz 80% AM modulation 6 V _{rms} in ISM band	3 V _{rms} on 150 kHz to 80 MHz 1 kHz 80% AM modulation 6 V _{rms} in ISM band	
Interference immunity test acc. to IEC 61000-4-39 for magnetic fields in close proximity	65 A/m at 134.2 kHz 7.5 A/m at 13.56 MHz	65 A/m at 134.2 kHz 7.5 A/m at 13.56 MHz	

9.4.2 Table 2 – Test levels for near fields from HF wireless communications equipment

Test frequency MHz	Frequency band MHz	Radio service	Modulation	Immunity test level V/m	Compliance level V/m
385	380 – 390	TETRA 400	Pulse modulation 18 Hz	27	27
450	430 – 470	GMRS 460, FRS 460	FM ± 5 kHz deviation 1 kHz sine wave	28	28
710	704 – 787	LTE band 13 and 17	Pulse modulation 217 Hz	9	9
745					
780					

Test frequency MHz	Frequency band MHz	Radio service	Modulation	Immunity test level V/m	Compliance level V/m
810	800 – 960	GSM 800/900, TETRA 800, iDEN 820, CDMA 850, LTE band 5	Pulse modulation 18 Hz	28	28
870					
930					
1720	1700 – 1990	GSM 1800, CDMA 1900, GSM 1900, DECT, LTE band 1, 3, 4, 25, UMTS	Pulse modulation 217 Hz	28	28
1845					
1970					
2450	2400 – 2570	Bluetooth, WLAN 802.11 b/g/n, RFID 2450, LTE Band 7	Pulse modulation 217 Hz	28	28
5240	5100 – 5800	WLAN 802.11 a/n	Pulse modulation 217 Hz	9	9
5500					
5785					

9.4.3 Table 3 – Test levels for radiated and conducted immunity tests

Guidelines and manufacturer's declaration – electromagnetic immunity

The product is intended for use in the electromagnetic environment specified below. The user of the product should make sure that it is used in such an environment.

Immunity tests	EN/IEC 60601-1-2 test level	Compliance level	Electromagnetic environment – guidelines
Conducted RF disturbances acc. to IEC 61000-4-6	3 V _{rms} 150 kHz to 80 MHz	3 V _{rms}	Portable and mobile HF communications equipment should be used no closer to any part of the product, including cables, than the recommended separation distance calculated from the equation applicable to the frequency of the transmitter. Recommended safety distances: $d = 1.2 \sqrt{P}$ Where P is the rated power of the transmitter in watts [W] according to the information provided by the transmitter manufacturer and d is the recommended separation distance in meters [m].
Radiated RF disturbances acc. to IEC 61000-4-3	3 V/m 80 MHz to 2.7 GHz 6 V for ISM frequency bands	3 V/m	

Immunity tests	EN/IEC 60601-1-2 test level	Compliance level	Electromagnetic environment – guidelines
			<p>Field strengths from fixed HF transmitters as determined by an electromagnetic site survey ^a should be less than the compliance level in each frequency range ^b.</p> <p>$d = 1.2 \sqrt{P}$ 80 MHz to 800 MHz</p> <p>$d = 2.3 \sqrt{P}$ 800 MHz to 2.7 GHz</p> <p>Interferences may occur in the vicinity of equipment marked with the following symbol:</p> 
<p>Note: At 80 MHz and 800 MHz, the higher frequency range applies.</p> <p>Note: These guidelines may not apply in all situations. The propagation of electromagnetic waves is affected by absorptions and reflections of buildings, objects, and people.</p>			
<p>^a The field strength of stationary transmitters, e.g., base stations for radio (cellular/cordless) telephones and land mobile radios, amateur radio, AM and FM radio broadcast, and TV broadcast cannot be predicted theoretically with accuracy. To assess the electromagnetic environment due to fixed transmitters, an electromagnetic site survey should be considered. If the measured field strength at the location where the device is used exceeds the above compliance levels, the device should be monitored to ensure proper function. If abnormal performance is observed, additional measures may be necessary, such as re-orienting or relocating the device.</p> <p>^b Over the frequency range from 150 kHz to 80 MHz, field strengths should be less than 3 V/m.</p>			

9.4.4 Table 4 – Emission class and group

Guidelines and manufacturer’s declaration – electromagnetic emissions

The product is intended for use in such an environment as specified below. The customer or user of the product should ensure that it is used in such an environment.

Interference emission measurements	Compliance	Electromagnetic environment – guidelines
HF emissions acc. to CISPR 11	Group 2	The product uses HF energy. This may interfere with nearby electronic devices.
HF emissions acc. to CISPR 11	Class A	The product is suitable for use in all establishments other than domestic and those directly connected to the public low voltage power supply network that supplies buildings used for domestic purposes.

9.4.5 Table 5 – Recommended separation distances between portable and mobile HF communications equipment and the product

The product is intended for use in an electromagnetic environment in which HF disturbances are controlled. The customer or user of the product can help prevent electromagnetic interference by maintaining a minimum distance between portable and mobile HF communications equipment (transmitters) and the product as recommended below, according to the output energy of the communications equipment.

Rated power of the transmitter [W]	Separation distance d [m] according to the transmitter frequency		
	150 kHz to 80 MHz $d = 1.2 \sqrt{P}$	80 MHz to 800 MHz $d = 1.2 \sqrt{P}$	800 MHz to 2.5 GHz $d = 2.3 \sqrt{P}$
0.01	0.12	0.12	0.23
0.1	0.38	0.38	0.73
1	1.2	1.2	2.3
10	3.8	3.8	7.3
100	12	12	23

For transmitters whose maximum rated power is not listed in the table above, the recommended separation distance d in meters (m) can be estimated using the equation from the respective column, whereby P is the maximum rated power of the transmitter in watts (W) according to the transmitter manufacturer.

Note: At 80 MHz and 800 MHz, the separation distance for the higher frequency range applies.

Note: These guidelines may not apply in all situations. The propagation of electromagnetic waves is affected by absorptions and reflections of buildings, objects, and people.

10 Errors and messages

10.1 Troubleshooting

Fault	Possible causes	Actions
Malfunctions		<ul style="list-style-type: none"> ▶ Disconnect the patient from the device ▶ Perform a technical inspection of the product ▶ Contact Service

10.2 EASY monitoring fault indication

EASY monitoring	Display	Cause	Actions
Lights up yellow		Significant increase in resistance. Depending on the indication, there may be heating under the neutral electrode	<ul style="list-style-type: none"> ▶ Check positioning of neutral electrode ▶ Resume application
Switches from green to continuous red	<ul style="list-style-type: none"> – Acoustic signal – Error message on touch screen 	Problem occurs when monopolar current is activated	<ul style="list-style-type: none"> ▶ Check neutral electrode and neutral electrode cable
	<ul style="list-style-type: none"> – Acoustic signal – Warning on touch screen 	Replacement neutral electrode	<ul style="list-style-type: none"> ▶ Correct positioning of neutral electrode ▶ Replace faulty neutral electrode

10.3 System messages

Message	Message text	Actions
Confirmation of AUTOSTART mode	You have selected an AUTOSTART mode	<ul style="list-style-type: none"> ▶ Ensure there is no unintentional coagulation, e.g., when gripping with bipolar forceps
AUTOSTART fault	The instrument is in contact with tissue	<ul style="list-style-type: none"> ▶ Open the instrument so AUTOSTART can be selected
Activation fault	While switching on the device, activation is performed by footswitch, fingerswitch, or AUTOSTART	<ul style="list-style-type: none"> ▶ Check the handle or footswitch for malfunctions. ▶ Disconnect the handle or footswitch from the product. ▶ Contact Service, contact information: MENU – SERVICE

Message	Message text	Actions
	Activation occurs when connecting the footswitch or finger-switch	<ul style="list-style-type: none"> ▶ Check the handle or footswitch for malfunctions. ▶ Disconnect the handle or footswitch from the product. ▶ Contact Service, contact information: MENU – SERVICE
	There is no instrument connected at the activated socket	<ul style="list-style-type: none"> ▶ Connect the instrument
Fingerswitch fault	Fault on fingerswitch connection	<ul style="list-style-type: none"> ▶ Check the handle and connection cable and replace if damaged ▶ Contact Service, contact information: MENU – SERVICE
Footswitch fault	No compatible footswitch	<ul style="list-style-type: none"> ▶ Connect compatible footswitch with changeover switch
	Footswitch not assigned to a socket	<ul style="list-style-type: none"> ▶ Assign a socket to the footswitch using the PEDAL button
	Error on footswitch connection	<ul style="list-style-type: none"> ▶ Check footswitch ▶ Contact Service, contact information: MENU – SERVICE
Mode fault	No mode selected	<ul style="list-style-type: none"> ▶ Select the desired mode or change the footswitch assignment
	This mode is not allowed for baby neutral electrodes	<ul style="list-style-type: none"> ▶ Use large split neutral electrodes and the suitable mode
	The chosen mode is not allowed for this socket	<ul style="list-style-type: none"> ▶ Choose another socket for this mode
Neutral electrode fault	No cable for the neutral electrode connected	<ul style="list-style-type: none"> ▶ Connect the neutral electrode
	Poor contact with the patient The transition resistance between the neutral electrode and the tissue is too high	<ul style="list-style-type: none"> ▶ Check contact of neutral electrode
	Wrong neutral electrode connected	<ul style="list-style-type: none"> ▶ Connect the suitable neutron electrode for the mode selected ▶ Change to suitable mode for the neutral electrode



Message	Message text	Actions
	No neutral electrode connected	<ul style="list-style-type: none"> ▶ Connect the neutral electrode
Activation warning	The mode for technical safety inspections is active	<ul style="list-style-type: none"> ▶ Leave technical safety inspection mode to enable activation
Bipolar resection warning		<ul style="list-style-type: none"> ▶ Use a coded KARL STORZ resection cable ▶ Use NaCl as irrigation fluid ▶ Ensure continuous irrigation during the application ▶ Use conductive lubricant ▶ Avoid continuous activations
Coding system warning	The maximum life span of the instrument has been reached. Any further use is not covered by warranty	<ul style="list-style-type: none"> ▶ Replace instrument
	A software update is necessary to use the coding system with this instrument	<ul style="list-style-type: none"> ▶ Set instrument manually ▶ Contact Service, contact information: MENU – SERVICE
	The preferred parameters for this coded instrument cannot be loaded.	<ul style="list-style-type: none"> ▶ Set instrument manually ▶ Contact Service, contact information: MENU – SERVICE
Intermittent 300 W/400 W Warning	Polypectomy snare has no tissue contact	<ul style="list-style-type: none"> ▶ Establish contact between tissue and polypectomy snare ▶ Check connecting cable at snare and generator ▶ Activate the snare with yellow foot pedal
Neutral electrode warning	Poor contact with the patient The transition resistance between the neutral electrode and the patient is getting worse	<ul style="list-style-type: none"> ▶ Check contact of neutral electrode
TSI warning	The annual Technical Safety Inspection (TSI) is due	<ul style="list-style-type: none"> ▶ Have a technical safety inspection performed
Temperature warning	Device temperature higher than normal	<ul style="list-style-type: none"> ▶ Allow the product to cool down to ensure maximum output is achieved
Coding system notice	The life span of the instrument is ending soon. Any use of the instrument beyond its life span is not covered by warranty	<ul style="list-style-type: none"> ▶ AUTOCON III 400 Contact trade partner and reorder instrument





Message	Message text	Actions
Neutral electrode notice	No cable for the neutral electrode connected	<ul style="list-style-type: none"> ▶ Connect neutral electrode cable to enable monopolar activation
Limitation of continuous activation	The maximum activation time has been exceeded	<ul style="list-style-type: none"> ▶ Activate the generator in short intervals
Internal error xxxx (e.g., xxxx = 4183)		<ul style="list-style-type: none"> ▶ Record error code ▶ Contact Service, contact information: MENU – SERVICE



11 Appendix



11.1 Monopolar modes

Monopolar cutting modes

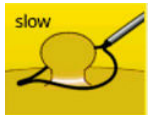

Symbol	Designation	CCS	ARC Control	HF voltage form	HF power limitation		Peak voltage output	Maximum current	Default values	
					Effect	Power range			Effect	Max. watts
	Cut reduced 200 W	Yes	Yes	Sinusoidal constant	1	1 W–200 W	400 Vp	2 A rms	5	100
					2		450 Vp			
					3		560 Vp			
					4		650 Vp			
					5		650 Vp			
					6		700 Vp			
					7		700 Vp			
					8		700 Vp			
					9		750 Vp			
	Cut	Yes	Yes	Sinusoidal constant	1	1 W–400 W	400 Vp	2 A rms	5	100
					2		450 Vp			
					3		560 Vp			
					4		650 Vp			
					5		650 Vp			
					6		700 Vp			
					7		700 Vp			
					8		700 Vp			



Symbol	Designation	CCS	ARC Control	HF voltage form	HF power limitation		Peak voltage output	Maximum current	Default values	
					Effect	Power range			Effect	Max. watts
					9		750 Vp			
	Cut reduced 50 W	Yes	Yes	Sinusoidal constant	1 2 3 4 5 6 7 8 9	1 W–50 W	280 Vp 340 Vp 380 Vp 400 Vp 400 Vp 400 Vp 450 Vp 450 Vp 450 Vp	1 A rms	5	20
	Resection	Yes	Yes	Sinusoidal constant	1 2 3 4 5	250 W	650 Vp 700 Vp 700 Vp 700 Vp 750 Vp	2 A rms	2	---
	Cut 300–400 W	Yes	Yes	Sinusoidal constant	1 2 3	300 W 350 W 400 W	650 Vp	2 A rms	1	---
	Cut blend	Yes	Yes	Sinusoidal constant	1 2 3 4	1 W–200 W	1.4 kVp 1.4 kVp 1.4 kVp 1.4 kVp	2 A rms	5	100

Symbol	Designation	CCS	ARC Control	HF voltage form	HF power limitation		Peak voltage output	Maximum current	Default values	
					Effect	Power range			Effect	Max. watts
					5		1.5 kVp			
					6		1.6 kVp			
					7		1.6 kVp			
					8		1.6 kVp			
					9		1.6 kVp			
	Intermittent 400 W 1	Yes	Yes	Sinusoidal alternating Cut, Coag, and Pause phases	1 2 3 4 5	400 W	750 Vp	2 A rms	3	---
	Intermittent 400 W 2	Yes	Yes	Sinusoidal alternating Cut, Coag, and Pause phases	1 2 3 4 5	400 W	750 Vp	2 A rms	3	---
	Intermittent 400 W 3	Yes	Yes	Sinusoidal alternating Cut, Coag, and Pause phases	1 2 3 4 5	400 W	750 Vp	2 A rms	3	---

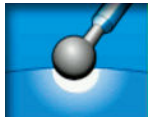
Symbol	Designation	CCS	ARC Control	HF voltage form	HF power limitation		Peak voltage output	Maximum current	Default values	
					Effect	Power range			Effect	Max. watts
	Intermittent 300 W 1	Yes	Yes	Sinusoidal alternating Cut and Coag phases	1 2 3 4 5	300 W	650 Vp 650 Vp 650 Vp 700 Vp 750 Vp	2 A rms	3	---
	Intermittent 300 W 2	Yes	Yes	Sinusoidal alternating Cut and Coag phases	1 2 3 4 5	300 W	650 Vp 650 Vp 650 Vp 700 Vp 750 Vp	2 A rms	3	---
	Intermittent 300 W 3	Yes	Yes	Sinusoidal alternating Cut and Coag phases	1 2 3 4 5	300 W	650 Vp 650 Vp 650 Vp 700 Vp 750 Vp	2 A rms	3	---





Monopolar coagulation modes



Symbol	Designation	CCS	ARC Control	HF voltage form	HF power limitation		Peak voltage output	Maximum current	Default values	
					Effect	Power range			Effect	Max. watts
	Forced Coag 1.8 kVp			Sinusoidal modulated	—	1 W–120 W	1.8 kVp	1.5 A rms	---	60
	Soft contact			Sinusoidal constant	1 2 3	1 W–120 W	250 Vp	1.3 A rms 1.8 A rms 2.5 A rms	2	60
	Forced Coag			Pulse modulated	—	1 W–80 W	3.5 kVp	0.3 A rms	---	50
	Resection			Sinusoidal modulated	—	1 W–120 W	2.2 kVp	1 A rms	---	60

Symbol	Designation	CCS	ARC Control	HF voltage form	HF power limitation		Peak voltage output	Maximum current	Default values	
					Effect	Power range			Effect	Max. watts
	Spray			Pulse modulated	1 2 3 4	1 W–120 W	3.0 kVp 3.8 kVp 4.6 kVp 5.0 kVp	0.5 A rms	2	80
	Forced mixed			Sinusoidal modulated	1 2 3	1 W–120 W	1.5 kVp 2.0 kVp 2.5 kVp	1 A rms	2	60
	Forced Coag with Cut			Sinusoidal modulated	1 2 3 4	1 W–250 W	1.5 kVp 1.5 kVp 1.3 kVp 1.3 kVp	1 A rms 1 A rms 2.5 A rms 3.5 A rms	2	80







11.2 Bipolar modes





Bipolar cutting modes

Symbol	Designation	CCS	ARC Control	HF voltage form	HF power limitation		Peak voltage output	Maximum current	Default values	
					Effect	Power range			Effect	Max. watts
	Bip. cutting	Yes	Yes	Sinusoidal constant	—	1 W–200 W	400 Vp	2 Arms	---	100
	Bip. scissors			Sinusoidal constant	—	1 W–120 W	200 Vp	2 Arms	---	40
	Bip. resection 15 Fr.	Yes	Yes	Sinusoidal constant	1 2 3 4	150 W 150 W 200 W 250 W	500 Vp	2 Arms	2	---
	Bip. resection	Yes	Yes	Sinusoidal constant	1 2 3	250 W	500 Vp	6 Arms	2	---

Symbol	Designation	CCS	ARC Control	HF voltage form	HF power limitation		Peak voltage output	Maximum current	Default values	
					Effect	Power range			Effect	Max. watts
	Bip. vaporization	Yes	Yes	Sinusoidal constant	1 2 3	300 W 300 W 400 W	350 Vp 400 Vp 450 Vp	6 Arms	2	---
	VAP CUT	Yes	Yes	Sinusoidal constant	1 2 3 4 5	120 W 200 W 200 W 200 W 200 W	290 Vp 330 Vp 380 Vp 440 Vp 500 Vp	6 Arms	3	---

Bipolar coagulation modes

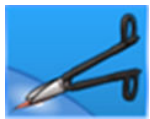
Symbol	Designation	CCS	ARC Control	HF voltage form	HF power limitation		Peak voltage output	Maximum current	Default values	
					Effect	Power range			Effect	Max. watts
	RoBi			Sinusoidal constant	–	1 W–100 W	110 Vp	2.5 Arms	---	40
	Standard plus			Sinusoidal constant	–	1 W–120 W	150 Vp	2 Arms	---	50
	Standard			Sinusoidal constant	–	1 W–120 W	150 Vp	2 Arms	---	40
	Bip. resection 15 Fr.	Yes		Sinusoidal constant	1 2 3 4	150 W 150 W 200 W 250 W	110 Vp 130 Vp 160 Vp 220 Vp	4 Arms	3	---
	Bip. resection			Sinusoidal constant	1 2 3 4	125 W 200 W 275 W 350 W	190 Vp	4 Arms	3	---
	Bip. vaporization			Sinusoidal constant	1 2 3	250 W	190 Vp 400 Vp 500 Vp	4 Arms	2	---

Symbol	Designation	CCS	ARC Control	HF voltage form	HF power limitation		Peak voltage output	Maximum current	Default values	
					Effect	Power range			Effect	Max. watts
	VAP COAG			Sinusoidal constant	1 2 3	40 W 60 W 80 W	110 Vp 150 Vp 550 Vp	4 Arms	2	---
	Standard AUTO			Sinusoidal constant	–	5 W–120 W	150 Vp	2 Arms	---	40
	Bipolar scissors			Sinusoidal constant	–	1 W–120 W	200 Vp	2 Arms	---	40
	Micro			Sinusoidal constant	–	0.1 W–40 W	90 Vp	1.3 Arms	---	10
	Forced			Sinusoidal modulated	–	1 W–100 W	550 Vp	2 Arms	---	50

11.3 Output, voltage, and current diagrams

11.3.1 Monopolar Cutting – Cut reduced 200 W



Measurement at ohmic resistances

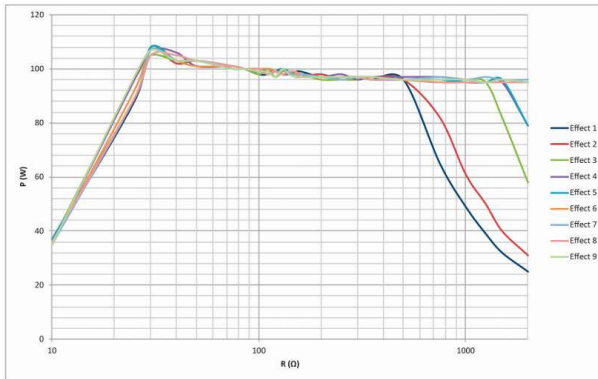

Diagram of power output P (W) as a function of the load resistance R (Ω) for the setting 'Monopolar Cutting Cut reduced 200 W' = 100 W

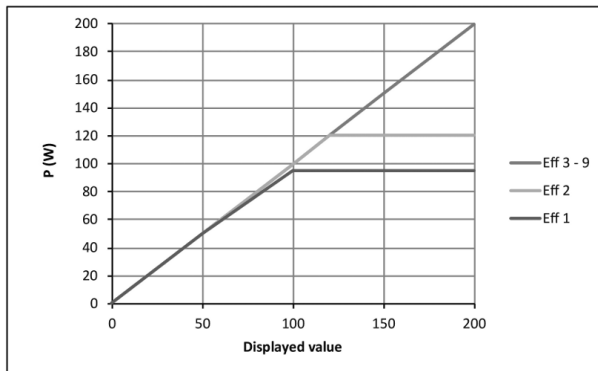

Diagram of power output P (W) as a function of the setting 'Monopolar Cutting Cut reduced 200 W'. Rated load resistance = 500 Ω

Measurement at ohmic resistances

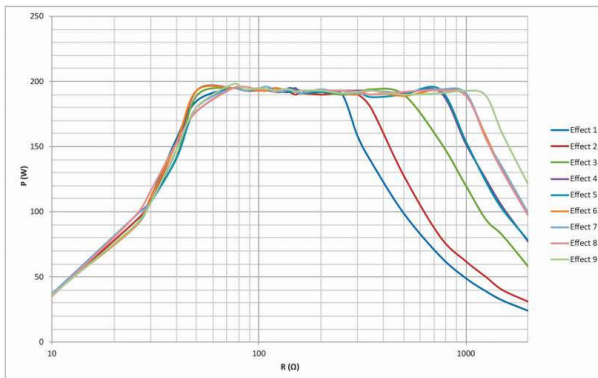

Diagram of power output P (W) as a function of the load resistance R (Ω) for the setting 'Monopolar Cutting Cut reduced 200 W' = 200 W

Effect	U (Vp)
1	400
2	450
3	560
4	650
5	650
6	700
7	700
8	700
9	750

Tab. 1: Table of HF output voltage U (Vp) as a function of the setting 'Monopolar Cutting Cut reduced 200 W' (idle mode)

11.3.2 Monopolar Cutting – Cut



Measurement at ohmic resistances

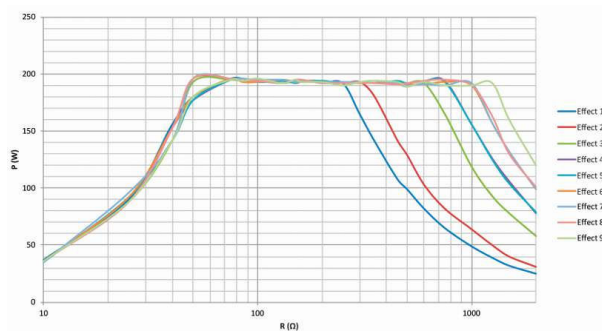

Diagram of power output P (W) as a function of the load resistance R (Ω) for the setting 'Monopolar Cutting Cut' = 200 W

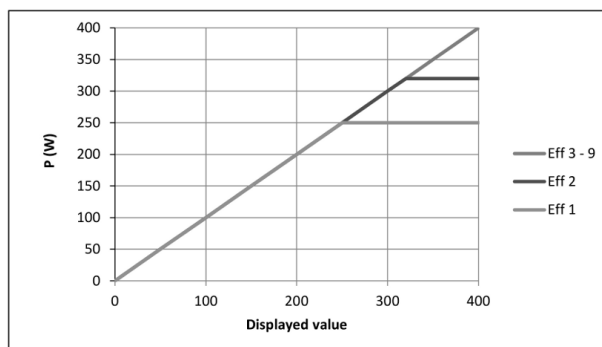

Diagram of power output P (W) as a function of the setting 'Monopolar Cutting Cut'. Rated load resistance = 200 Ω

Measurement at ohmic resistances

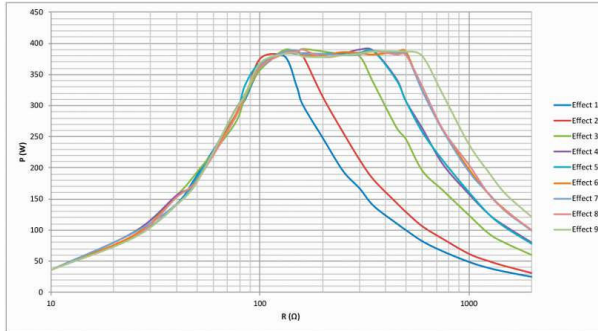

Diagram of power output P (W) as a function of the load resistance R (Ω) for the setting 'Monopolar Cutting Cut' = 400 W

Effect	U (Vp)
1	400
2	450
3	560
4	650
5	650
6	700
7	700
8	700
9	750

Tab. 2: Table of HF output voltage U (Vp) as a function of the setting 'Monopolar Cutting Cut' (idle mode)

11.3.3 Monopolar Cutting – Cut reduced 50 W



Measurement at ohmic resistances

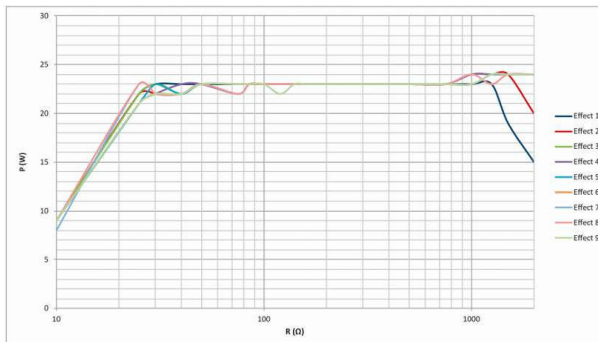

Diagram of power output P (W) as a function of the load resistance R [Ω] for the setting 'Monopolar Cutting Cut reduced 50 W' = 25 W

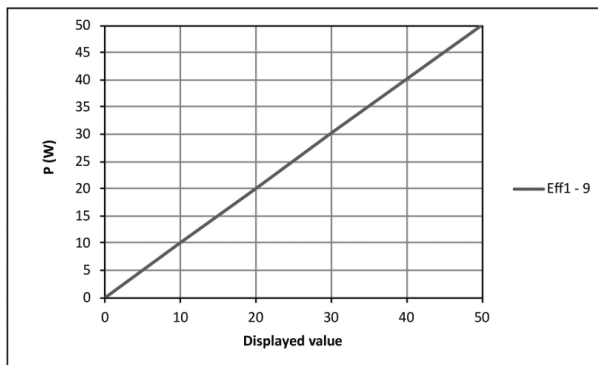

Diagram of power output P (W) as a function of the setting 'Monopolar Cutting Monopolar Cut reduced 50 W'. Rated load resistance = 500Ω

Measurement at ohmic resistances

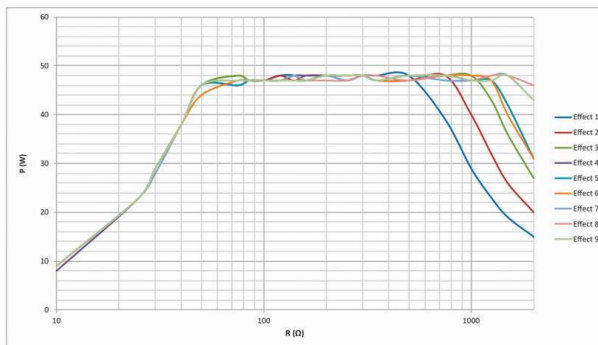

Diagram of power output P (W) as a function of the load resistance R (Ω) for the setting 'Monopolar Cutting Cut reduced 50 W' = 50 W

Effect	U (Vp)
1	280
2	340
3	380
4	400
5	400
6	400
7	450
8	450
9	450

Tab. 3: Table of HF output voltage U (Vp) as a function of the setting 'Monopolar Cutting Cut reduced 50 W' (idle mode)

11.3.4 Monopolar Cutting – Resection



Measurement at ohmic resistances

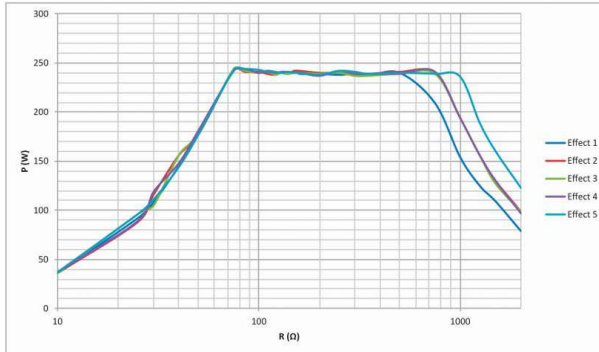

Diagram of power output P (W) as a function of the load resistance R (Ω) for the setting 'Monopolar Cutting Resection'

Effect	P (W)
1	250
2	250
3	250
4	250
5	250

Tab. 4: Table of power output P (W) as a function of the setting 'Monopolar Cutting Resection'. Rated load resistance = 500 Ω

Effect	U (Vp)
1	650
2	700
3	700
4	700
5	750

Tab. 5: Table of HF output voltage U (Vp) as a function of the setting 'Monopolar Cutting Resection' (idle mode)

11.3.5 Monopolar Cutting – Cut 300–400 W



Measurement at ohmic resistances

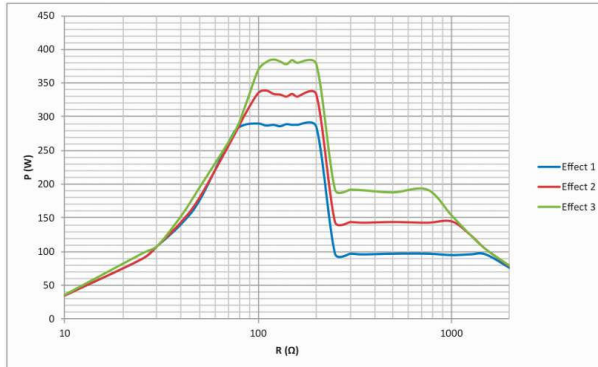

Diagram of power output P (W) as a function of the load resistance R (Ω) for the setting ‘Monopolar Cutting Cut 300–400 W’

Effect	P (W)
1	300
2	350
3	400

Tab. 6: Table of power output P (W) as a function of the setting ‘Monopolar Cutting Cut 300–400 W’. Rated load resistance = 100 Ω

Effect	U (Vp)
1	650
2	650
3	650

Tab. 7: Table of HF output voltage U (Vp) as a function of the setting ‘Monopolar Cutting Cut 300–400 W’ (idle mode)

11.3.6 Monopolar Cutting – Cut blend



Measurement at ohmic resistances

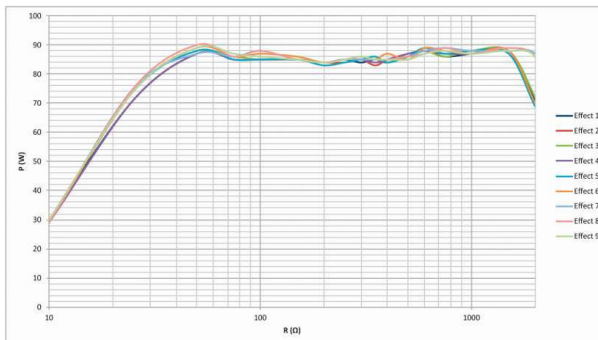

Diagram of power output P (W) as a function of the load resistance R (Ω) for the setting ‘Monopolar Cutting Cut blend’ = 100 W

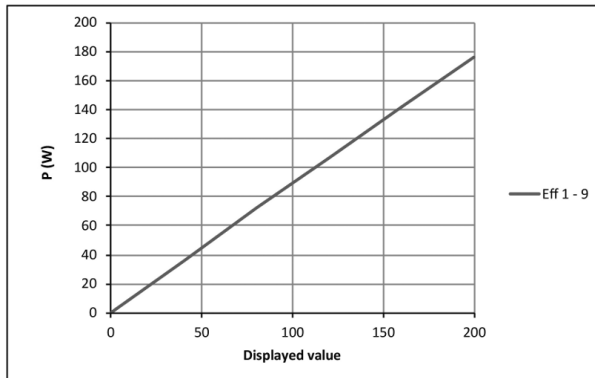

Diagram of power output P (W) as a function of the setting 'Monopolar Cutting Cut blend'. Rated load resistance = 500Ω

Measurement at ohmic resistances

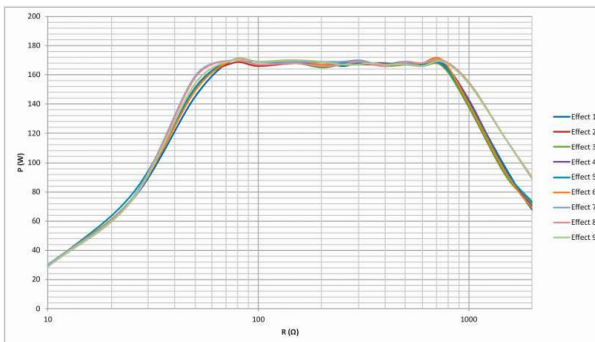

Diagram of power output P (W) as a function of the load resistance R (Ω) for the setting 'Monopolar Cutting Cut blend' = 200 W

Effect	U (Vp)
1	1,400
2	1,400
3	1,400
4	1,400
5	1,500
6	1,600
7	1,600
8	1,600
9	1,600

Tab. 8: Table of HF output voltage U (Vp) as a function of the setting 'Monopolar Cutting Cut blend' (idle mode)

11.3.7 Monopolar Cutting – Intermittent 400 W 1



Measurement at ohmic resistances

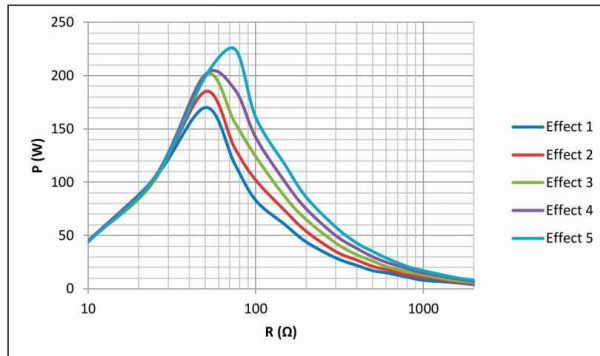

Diagram of power output P (W) as a function of the load resistance R (Ω) for the setting ‘Monopolar Cutting Intermittent 400 W 1’ Coag phase

Effect	P (W) Coag phase	P (W) Cut phase
1	17	400
2	21	400
3	26	400
4	30	400
5	35	400

Tab. 9: Table of power output P (W) as a function of the setting ‘Monopolar Cutting Intermittent 400 W 1’.

Rated load resistance = 500 Ω

Measurement at ohmic resistances

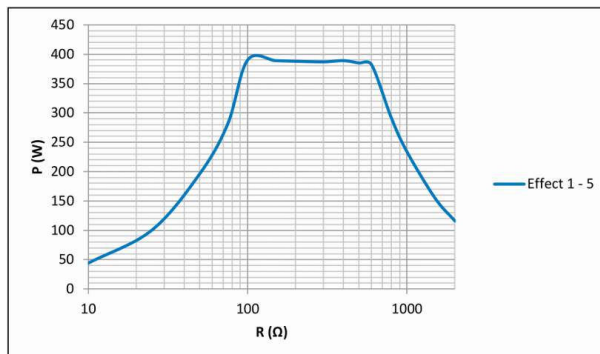
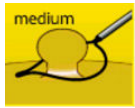

Diagram of power output P (W) as a function of the load resistance R (Ω) for the setting ‘Monopolar Cutting Intermittent 400 W 1’ Cut phase

Effect	U (Vp)
1	750
2	750
3	750
4	750
5	750

Tab. 10: Table of HF output voltage U (Vp) as a function of the setting 'Monopolar Cutting Intermittent 400 W 1' (idle mode)

11.3.8 Monopolar Cutting – Intermittent 400 W 2



Measurement at ohmic resistances

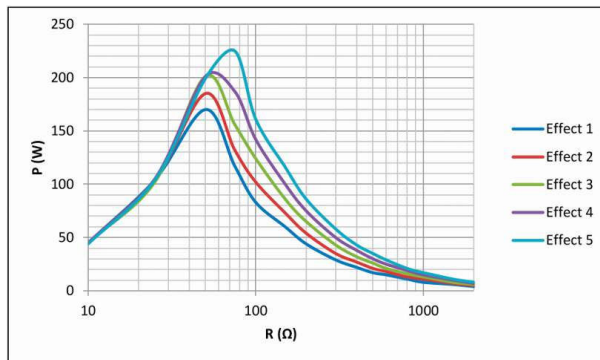

Diagram of power output P (W) as a function of the load resistance R (Ω) for the setting 'Monopolar Cutting Intermittent 400 W 2' Coag phase

Effect	P (W) Coag phase	P (W) Cut phase
1	17	400
2	21	400
3	26	400
4	30	400
5	35	400

Tab. 11: Table of power output P (W) as a function of the setting 'Monopolar Cutting Intermittent 400 W 2'.

Rated load resistance = 500 Ω

Measurement at ohmic resistances

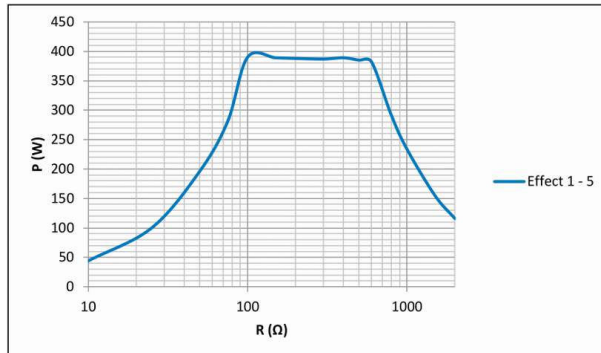
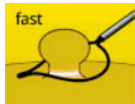

Diagram of power output P (W) as a function of the load resistance R (Ω) for the setting 'Monopolar Cutting Intermittent 400 W 2' Cut phase

Effect	U (Vp)
1	750
2	750
3	750
4	750
5	750

Tab. 12: Table of HF output voltage U (Vp) as a function of the setting 'Monopolar Cutting Intermittent 400 W 2' (idle mode)

11.3.9 Monopolar Cutting – Intermittent 400 W 3



Measurement at ohmic resistances

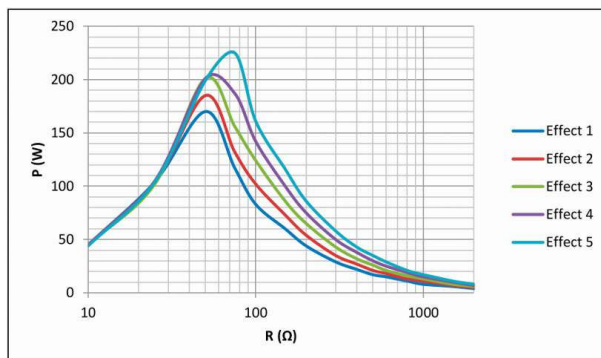

Diagram of power output P (W) as a function of the load resistance R (Ω) for the setting 'Monopolar Cutting Intermittent 400 W 3' Coag phase

Effect	P (W) Coag phase	P (W) Cut phase
1	17	400
2	21	400
3	26	400
4	30	400
5	35	400

Tab. 13: Table of power output P (W) as a function of the setting 'Monopolar Cutting Intermittent 400 W 3'.

Rated load resistance = 500 Ω

Measurement at ohmic resistances

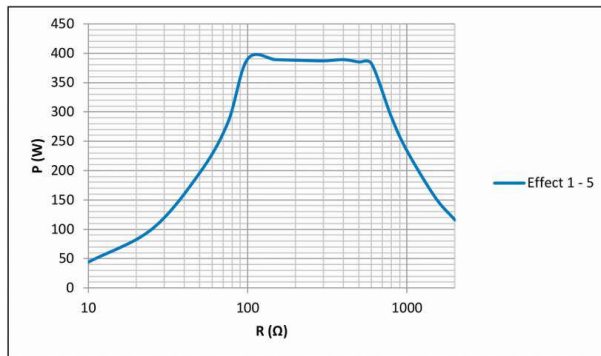

Diagram of power output P (W) as a function of the load resistance R (Ω) for the setting 'Monopolar Cutting Intermittent 400 W 3' Cut phase

Effect	U (Vp)
1	750
2	750
3	750
4	750
5	750

Tab. 14: Table of HF output voltage U (Vp) as a function of the setting 'Monopolar Cutting Intermittent 400 W 3' (idle mode)

11.3.10 Monopolar Cutting – Intermittent 300 W 1



Measurement at ohmic resistances

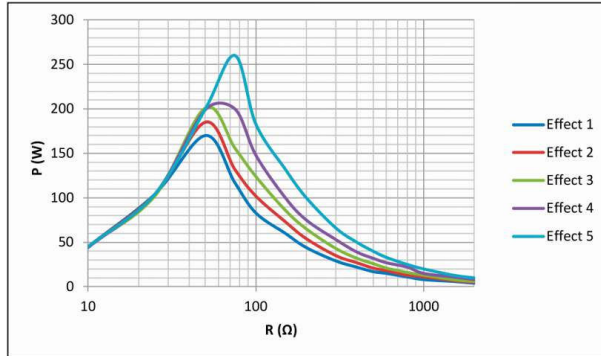

Diagram of power output P (W) as a function of the load resistance R (Ω) for the setting 'Monopolar Cutting Intermittent 300 W 1' Coag phase

Effect	P (W) Coag phase	P (W) Cut phase
1	17	300
2	21	300
3	26	300
4	32	300
5	40	300

Tab. 15: Table of power output P (W) as a function of the setting 'Monopolar Cutting Intermittent 300 W 1'.

Rated load resistance = 500 Ω

Measurement at ohmic resistances

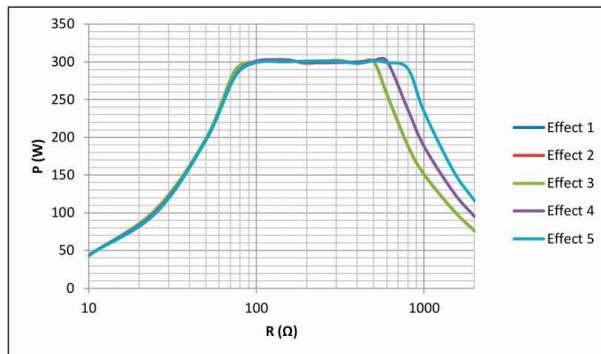

Diagram of power output P (W) as a function of the load resistance R (Ω) for the setting 'Monopolar Cutting Intermittent 300 W 1' Cut phase

Effect	U (Vp)
1	650
2	650
3	650
4	700
5	750

Tab. 16: Table of HF output voltage U (Vp) as a function of the setting 'Monopolar Cutting Intermittent 300 W 1' (idle mode)

11.3.11 Monopolar Cutting – Intermittent 300 W 2



Measurement at ohmic resistances

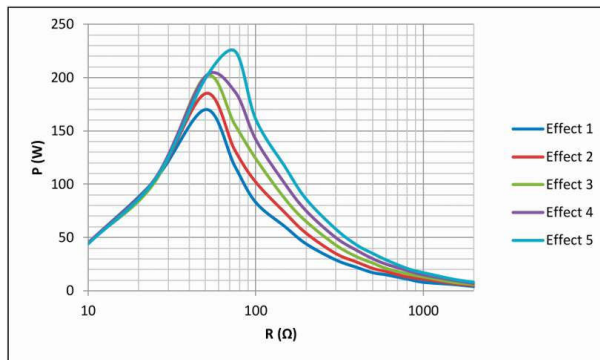

Diagram of power output P (W) as a function of the load resistance R (Ω) for the setting 'Monopolar Cutting Intermittent 300 W 2' Coag phase

Effect	P (W) Coag phase	P (W) Cut phase
1	17	300
2	21	300
3	26	300
4	32	300
5	40	300

Tab. 17: Table of power output P (W) as a function of the setting 'Monopolar Cutting Intermittent 300 W 2'.

Rated load resistance = 500 Ω

Measurement at ohmic resistances

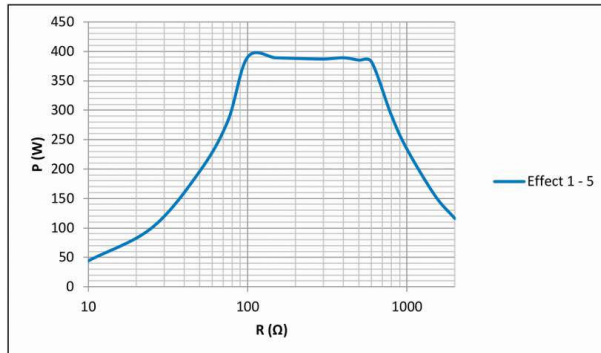

Diagram of power output P (W) as a function of the load resistance R (Ω) for the setting 'Monopolar Cutting Intermittent 300 W 2' Cut phase

Effect	U (Vp)
1	650
2	650
3	650
4	700
5	750

Tab. 18: Table of HF output voltage U (Vp) as a function of the setting 'Monopolar Cutting Intermittent 300 W 2' (idle mode)

11.3.12 Monopolar Cutting – Intermittent 300 W 3



Measurement at ohmic resistances

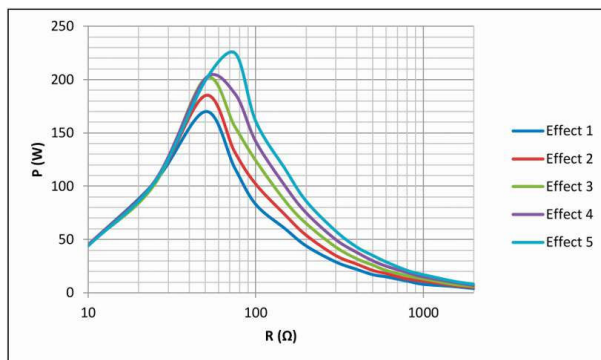

Diagram of power output P (W) as a function of the load resistance R (Ω) for the setting 'Monopolar Cutting Intermittent 300 W 3' Coag phase

Effect	P (W) Coag phase	P (W) Cut phase
1	17	300
2	21	300
3	26	300
4	32	300
5	40	300

Tab. 19: Table of power output P (W) as a function of the setting 'Monopolar Cutting Intermittent 300 W 3'.

Rated load resistance = 500 Ω

Measurement at ohmic resistances

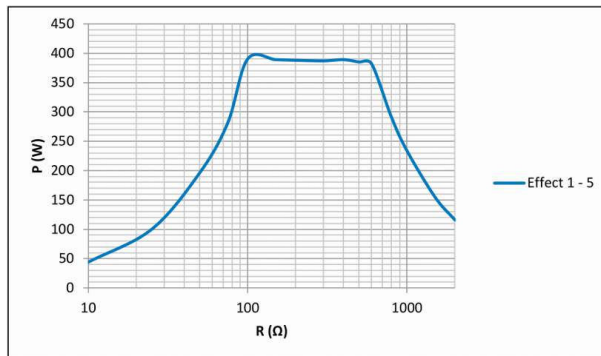

Diagram of power output P (W) as a function of the load resistance R (Ω) for the setting 'Monopolar Cutting Intermittent 300 W 3' Cut phase

Effect	U (Vp)
1	650
2	650
3	650
4	700
5	750

Tab. 20: Table of HF output voltage U (Vp) as a function of the setting 'Monopolar Cutting Intermittent 300 W 3' (idle mode)

11.3.13 Monopolar Coagulation – Forced Coag 1.8 kVp



Measurement at ohmic resistances

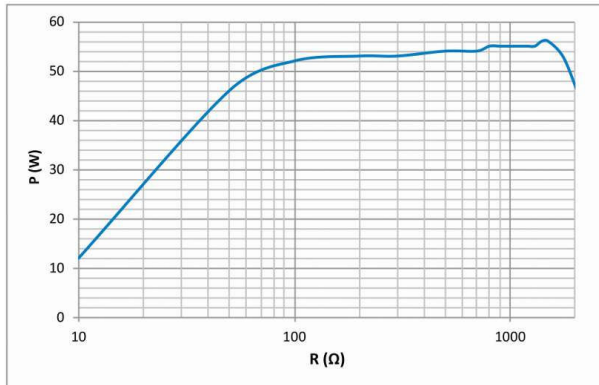

Diagram of power output P (W) as a function of the load resistance R (Ω) for the setting 'Monopolar Coagulation Forced Coag 1.8 kVp' = 60 W

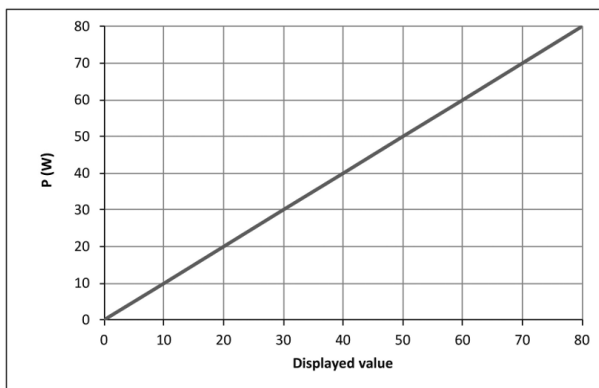

Diagram of power output P (W) as a function of the setting 'Monopolar Coagulation Forced Coag 1.8 kVp'. Rated load resistance = 500 Ω

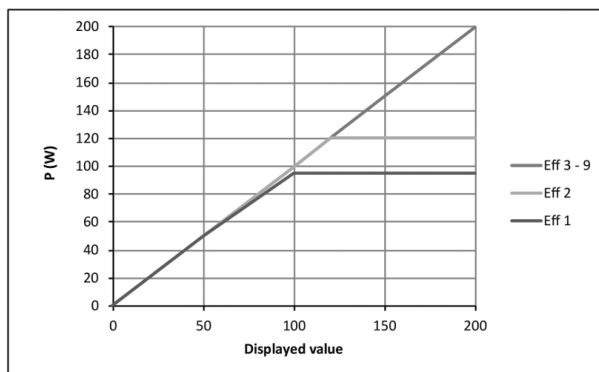

Diagram of power output P (W) as a function of the setting 'Monopolar Coagulation Forced Coag 1.8 kVp'. Rated load resistance = 500 Ω

Measurement at ohmic resistances

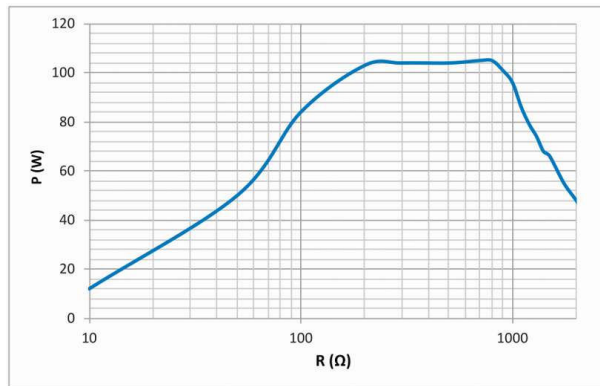
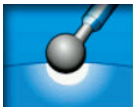

Diagram of power output P (W) as a function of the load resistance R (Ω) for the setting 'Monopolar Coagulation Forced Coag 1.8 kVp' = 120 W

HF output voltage U (Vp) with the setting 'Monopolar Coagulation Forced Coag 1.8 kVp' (idle mode) = 1,800 Vp

11.3.14 Monopolar Coagulation – Soft Contact



Measurement at ohmic resistances

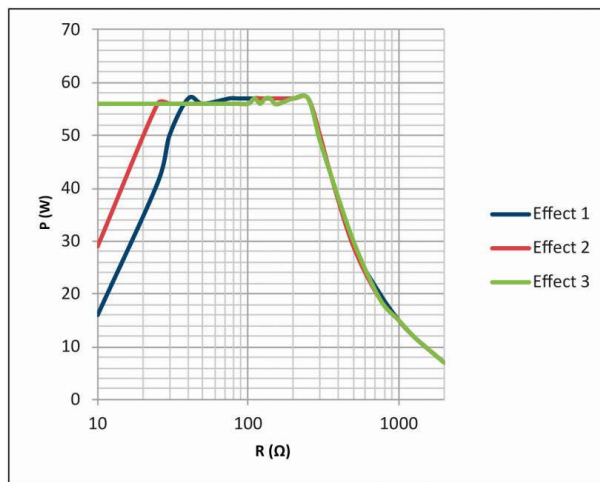

Diagram of power output P (W) as a function of the load resistance R (Ω) for the setting 'Monopolar Coagulation Soft Contact' = 60 W

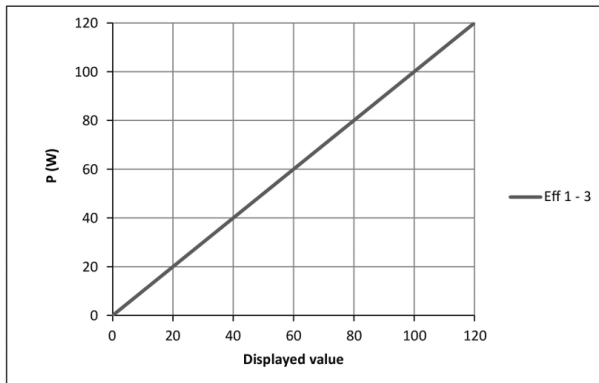

Diagram of power output P (W) as a function of the setting 'Monopolar Coagulation Soft Contact'.
Rated load resistance = 75Ω

Measurement at ohmic resistances

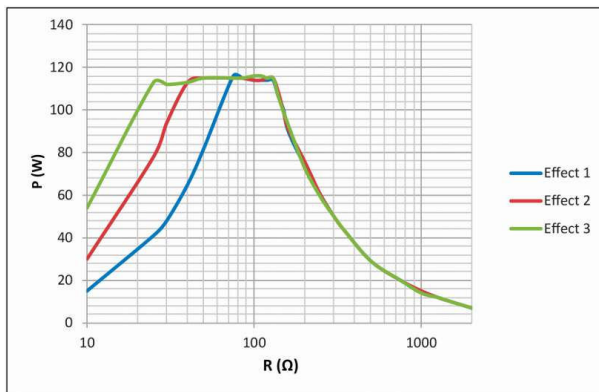

Diagram of power output P (W) as a function of the load resistance R (Ω) for the setting 'Monopolar Coagulation Soft Contact' = 120 W

Effect	U (Vp)
1	250
2	250
3	250

Tab. 21: Table of HF output voltage U (Vp) as a function of the setting 'Monopolar Coagulation Soft Contact' (idle mode)

11.3.15 Monopolar Coagulation – Forced Coag



Measurement at ohmic resistances

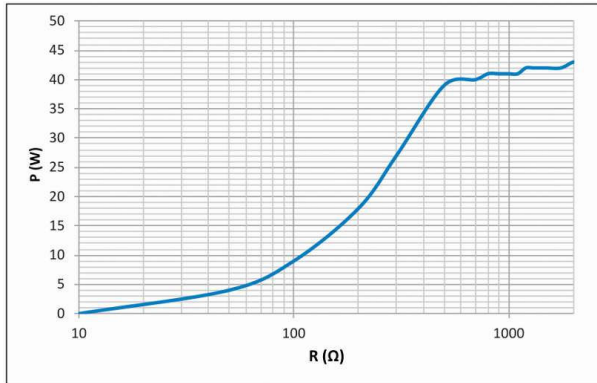

Diagram of power output P (W) as a function of the load resistance R (Ω) for the setting 'Monopolar Coagulation Forced Coag' = 40 W

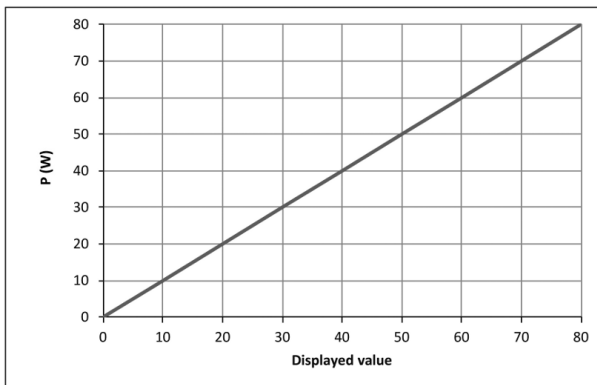

Diagram of power output P (W) as a function of the setting 'Monopolar Coagulation Forced Coag'. Rated load resistance = 1,000 Ω

Measurement at ohmic resistances

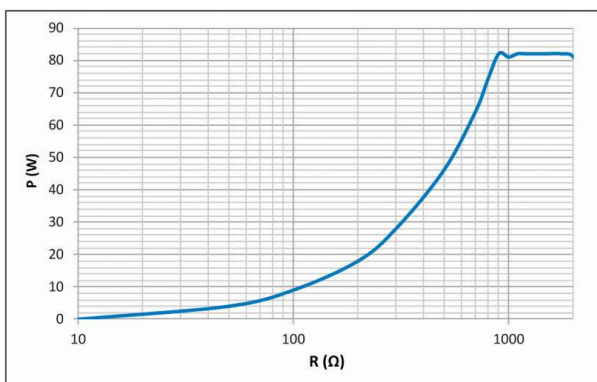

Diagram of power output P (W) as a function of the load resistance R (Ω) for the setting 'Monopolar Coagulation Forced Coag' = 80 W

HF output voltage U (Vp) with the setting 'Monopolar Coagulation Forced Coag' (idle mode) = 3,500 Vp

11.3.16 Monopolar Coagulation – Resection



Measurement at ohmic resistances

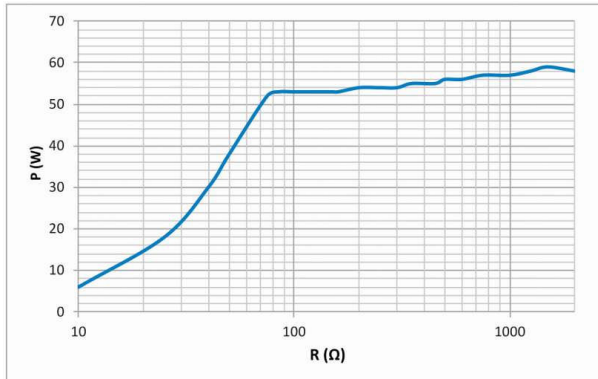

Diagram of power output P (W) as a function of the load resistance R (Ω) for the setting 'Monopolar Coagulation Resection' = 60 W

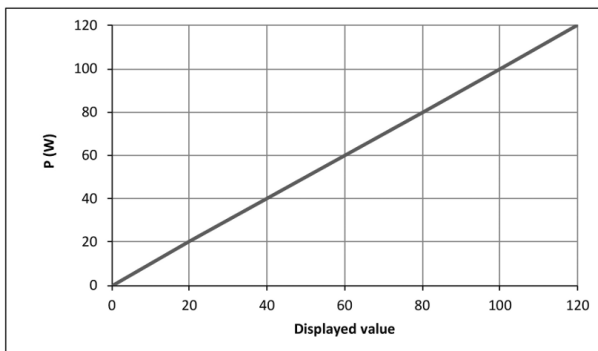

Diagram of power output P (W) as a function of the setting 'Monopolar Coagulation Resection'. Rated load resistance = 500 Ω

Measurement at ohmic resistances

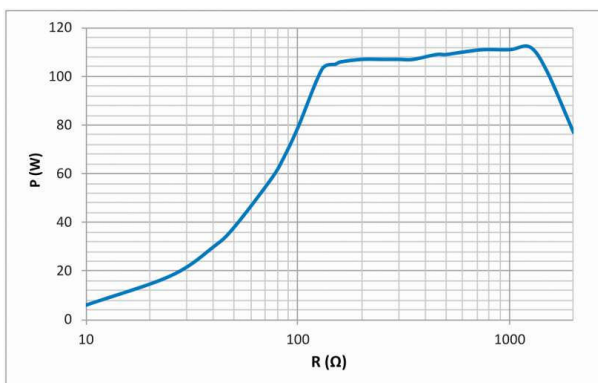

Diagram of power output P (W) as a function of the load resistance R (Ω) for the setting 'Monopolar Coagulation Resection' = 120 W

HF output voltage U (Vp) with the setting 'Monopolar Coagulation Resection' (idle mode) = 2,200 Vp

11.3.17 Monopolar Coagulation – Spray



Measurement at ohmic resistances

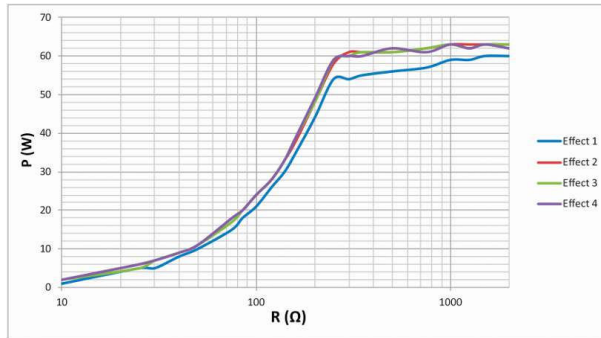

Diagram of power output P (W) as a function of the load resistance R (Ω) for the setting 'Monopolar Coagulation Spray' = 60 W

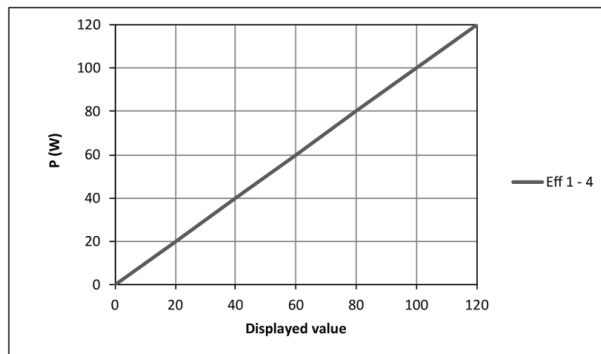

Diagram of power output P (W) as a function of the setting 'Monopolar Coagulation Spray'. Rated load resistance = 500 Ω

Measurement at ohmic resistances

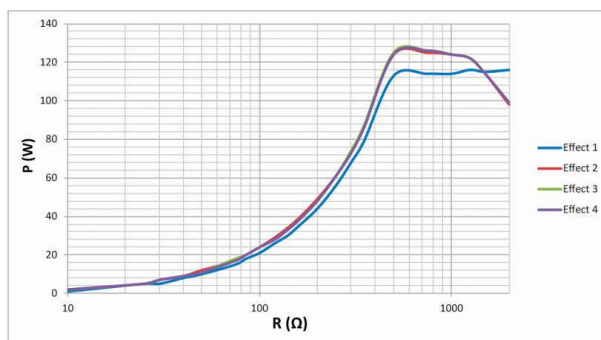

Diagram of power output P (W) as a function of the load resistance R (Ω) for the setting 'Monopolar Coagulation Spray' = 120 W

Effect	U (Vp)
1	3,000
2	3,800
3	4,600
4	5,000

Tab. 22: Diagram of HF output voltage U (Vp) as a function of the setting 'Monopolar Coagulation Spray' (idle mode)

11.3.18 Monopolar Coagulation – Forced mixed



Measurement at ohmic resistances

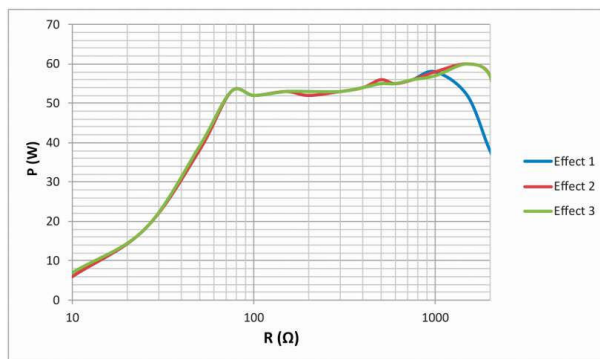

Diagram of power output P (W) as a function of the load resistance R (Ω) for the setting 'Monopolar Coagulation Forced mixed' = 60 W

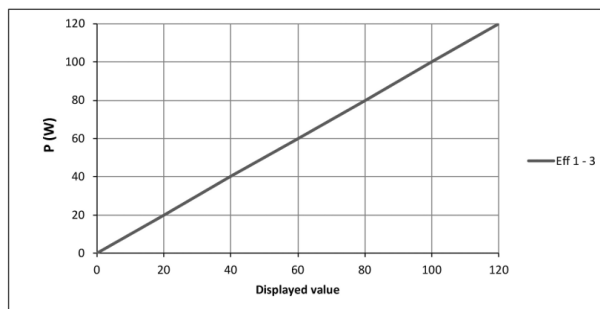

Diagram of power output P (W) as a function of the setting 'Monopolar Coagulation Forced mixed'. Rated load resistance = 500 Ω

Measurement at ohmic resistances

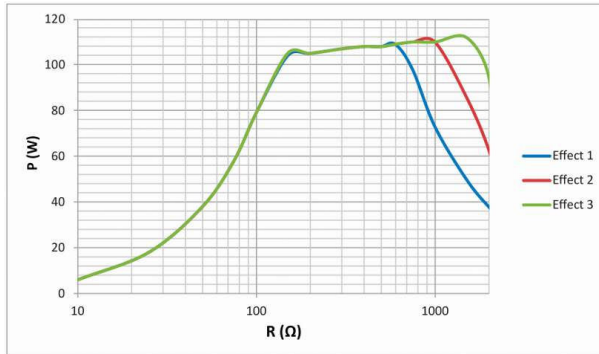

Diagram of power output P (W) as a function of the load resistance R (Ω) for the setting 'Monopolar Coagulation Forced mixed' = 120 W

Effect	U (Vp)
1	1,500
2	2,000
3	2,500

Tab. 23: Table of HF output voltage U (Vp) as a function of the setting 'Monopolar Coagulation Forced mixed' (idle mode)

11.3.19 Monopolar Coagulation – Forced Coag with Cut



Measurement at ohmic resistances

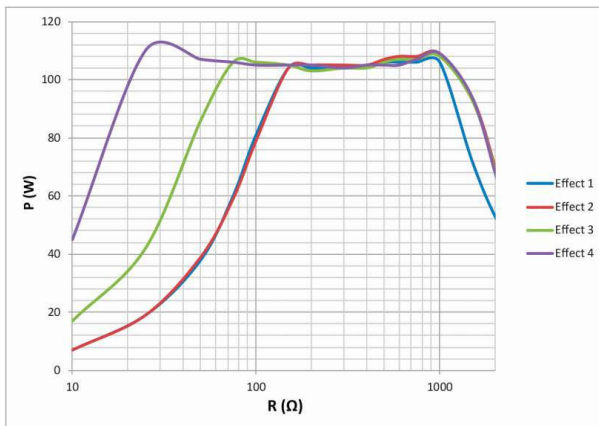

Diagram of power output P (W) as a function of the load resistance R (Ω) for the setting 'Monopolar Coagulation Forced Coag with Cut' = 125 W

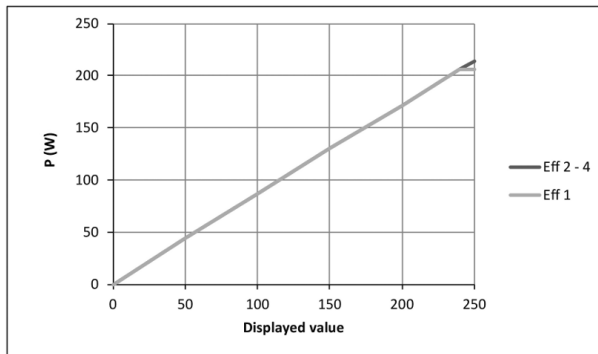

Diagram of power output P (W) as a function of the setting 'Monopolar Coagulation Forced Coag with Cut'. Rated load resistance = 500Ω

Measurement at ohmic resistances

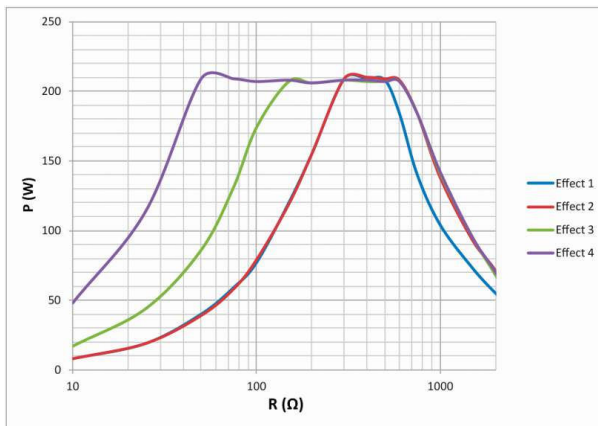

Diagram of power output P (W) as a function of the load resistance R (Ω) for the setting 'Monopolar Coagulation Forced Coag with Cut' = 250 W

Effect	U (Vp)
1	1,500
2	1,500
3	1,300
4	1,300

Tab. 24: Table of HF output voltage U (Vp) as a function of the setting 'Monopolar Coagulation Forced Coag with Cut' (idle mode)

11.3.20 Bipolar Cutting – Bip. Cutting



Measurement at ohmic resistances

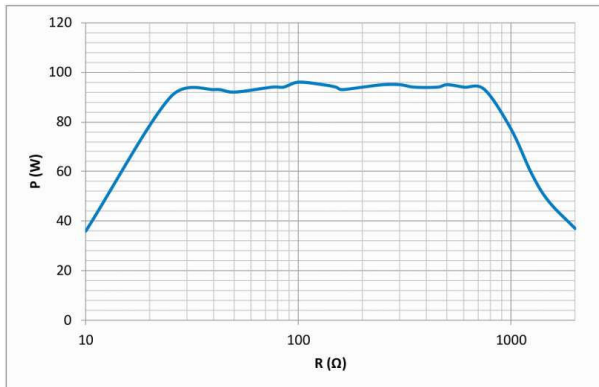

Diagram of power output P (W) as a function of the load resistance R (Ω) for the setting 'Bipolar Cutting Bip. Cutting' = 100 W

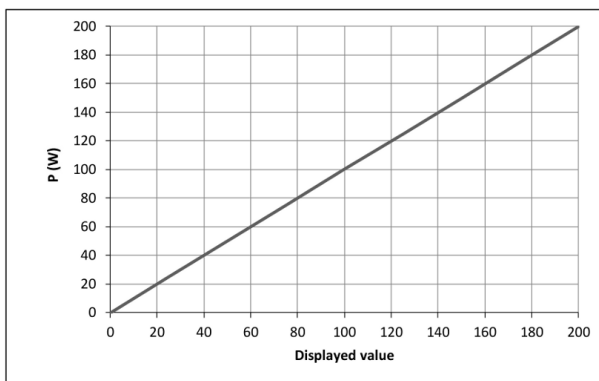

Diagram of power output P (W) as a function of the setting 'Bipolar Cutting Bip. Cutting'. Rated load resistance = 75 Ω

Measurement at ohmic resistances

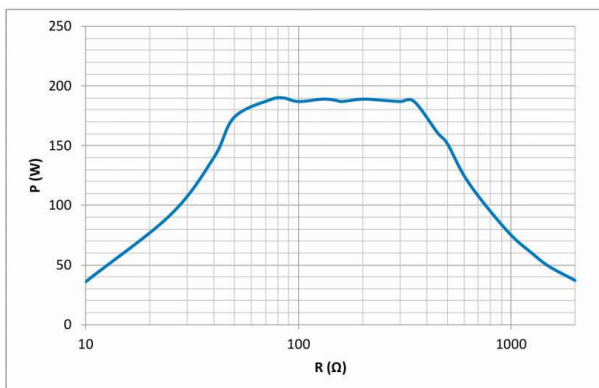

Diagram of power output P (W) as a function of the load resistance R (Ω) for the setting 'Bipolar Cutting Bip. Cutting' = 200 W

HF output voltage U (Vp) with the setting 'Bipolar Cutting Bip. Cutting' (idle mode) = 400 Vp

11.3.21 Bipolar Cutting – Bipolar Scissors



Measurement at ohmic resistances

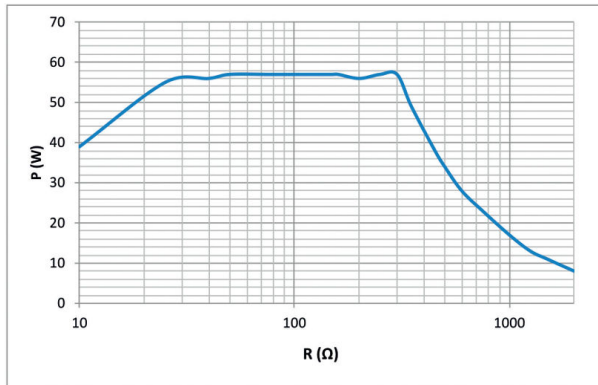

Diagram of power output P (W) as a function of the load resistance R (Ω) for the setting 'Bipolar Cutting Bipolar Scissors' = 60 W

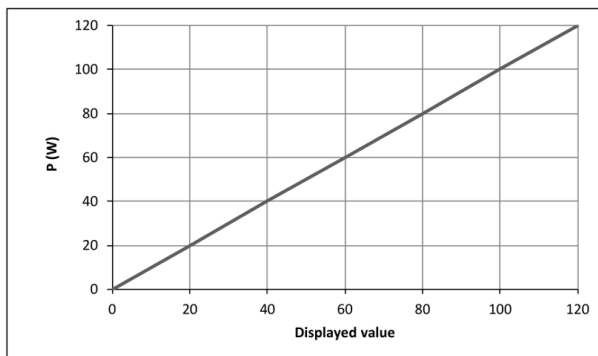

Diagram of power output P (W) as a function of the setting 'Bipolar Cutting Bipolar Scissors'. Rated load resistance = 75 Ω

Measurement at ohmic resistances

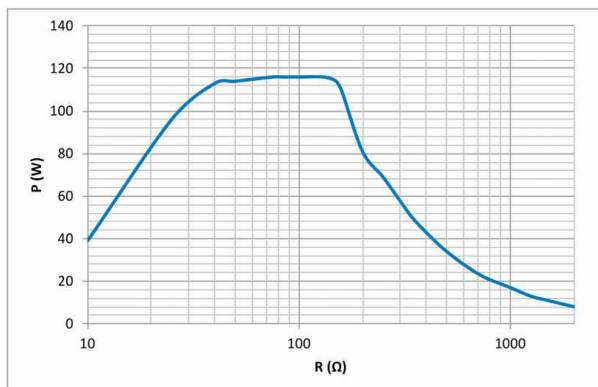

Diagram of power output P (W) as a function of the load resistance R (Ω) for the setting 'Bipolar Cutting Bipolar Scissors' = 120 W

HF output voltage U (Vp) with the setting 'Bipolar Cutting Bipolar Scissors' (idle mode) = 200 Vp

11.3.22 Bipolar Cutting – Bip. Resection 15 Fr.



Measurement at ohmic resistances

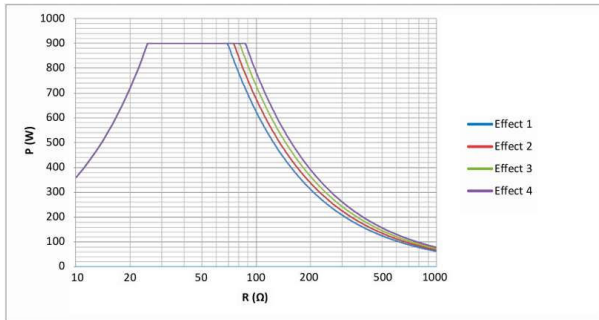

Diagram of power output P (W) as a function of the load resistance R (Ω) for the setting “Bipolar Cutting Bip. Resection 15 Fr.”, cut phase

Effect	P (W)
1	150
2	150
3	200
4	250

Tab. 25: Table of power output P (W) as a function of the setting “Bipolar Cutting Bip. Resection 15 Fr.”.

Rated load resistance = 75 Ω

Measurement at ohmic resistances

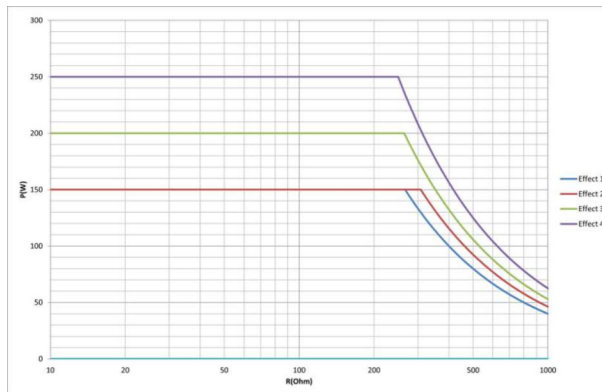

Diagram of power output P (W) as a function of the load resistance R (Ω) for the setting “Bipolar Cutting Bip. Resection 15 Fr.”, phase after the cut

Effect	U (Vp)
1	500
2	500
3	500
4	500

Tab. 26: Table of HF output voltage U (Vp) as a function of the setting “Bipolar Cutting Bip. Resection 15 Fr.” (idle mode)

11.3.23 Bipolar Cutting – Bip. Resection



Measurement at ohmic resistances

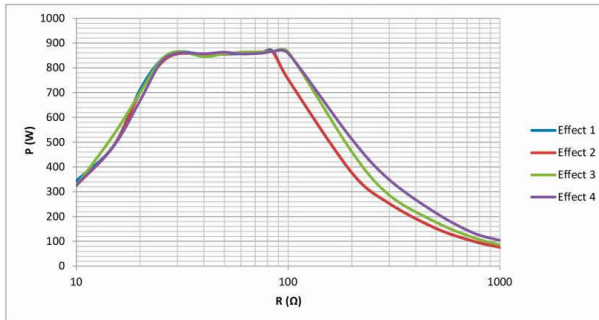

Diagram of power output P (W) as a function of the load resistance R (Ω) for the setting 'Bipolar Cutting Bip. Resection' Initial cut phase

Effect	P (W)
1	250
2	250
3	250
4	250

Tab. 27: Table of power output P (W) as a function of the setting 'Bipolar Cutting Bip. Resection'. Rated load resistance = 75Ω

Measurement at ohmic resistances

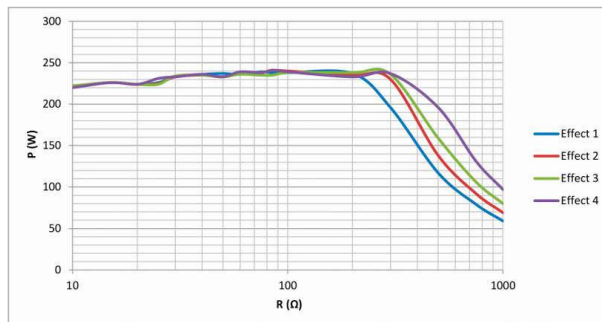

Diagram of power output P (W) as a function of the load resistance R (Ω) for the setting 'Bipolar Cutting Bip. Resection' Phase after initial cut

Effect	U (Vp)
1	500
2	500
3	500
4	500

Tab. 28: Table of HF output voltage U (Vp) as a function of the setting 'Bipolar Cutting Bip. Resection' (idle mode)

11.3.24 Bipolar Cutting – Bip. Vaporization



Measurement at ohmic resistances

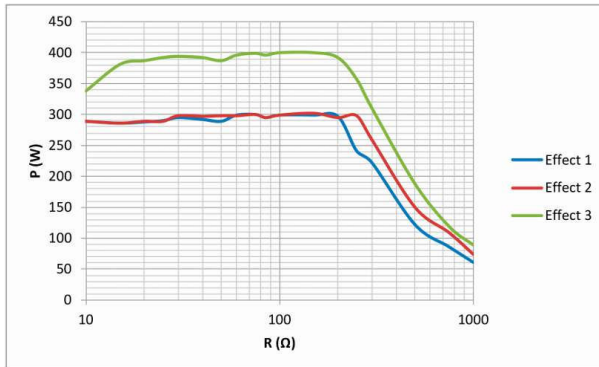

Diagram of power output P (W) as a function of the load resistance R (Ω) for the setting ‘Bipolar Cutting Bip. Vaporization’

Effect	P (W)
1	300
2	300
3	400

Tab. 29: Table of power output P (W) as a function of the setting ‘Bipolar Cutting Bip. Vaporization’. Rated load resistance = 75Ω

Effect	U (Vp)
1	350
2	400
3	450

Tab. 30: Table of HF output voltage U (Vp) as a function of the setting ‘Bipolar Cutting Bip. Vaporization’ (idle mode)

11.3.25 Bipolar Cutting – VAP CUT



Measurement at ohmic resistances

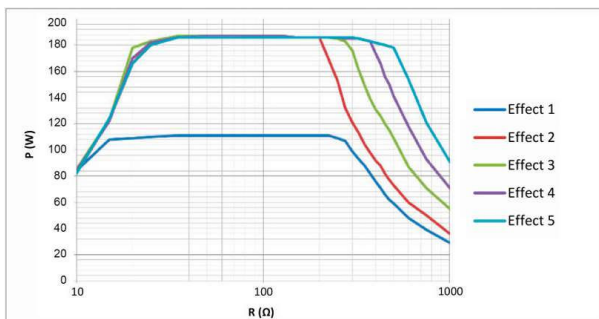

Diagram of power output P (W) as a function of the load resistance R (Ω) for the setting “Bipolar Cutting Arthro VAP CUT”

Effect	P (W)
1	120
2	200
3	200
4	200
5	200

Tab. 31: Table of power output P (W) as a function of the setting "Bipolar Cutting Arthro VAP CUT". Rated load resistance = 75Ω

Effect	U (Vp)
1	290
2	330
3	380
4	440
5	500

Tab. 32: Table of HF output voltage U (Vp) as a function of the setting "Bipolar Cutting Arthro VAP CUT" (idle mode)

11.3.26 Bipolar coagulation – RoBi



Measurement at ohmic resistances

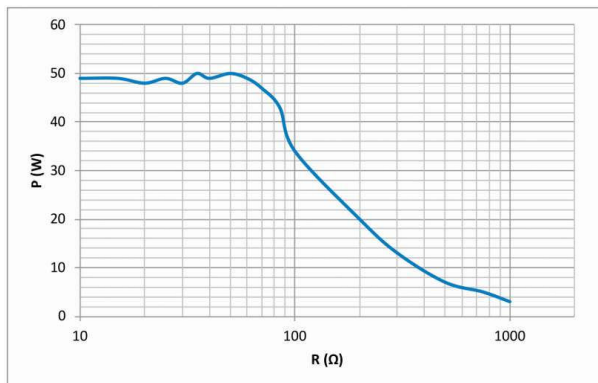

Diagram of power output P (W) as a function of the load resistance R (Ω) for the setting 'Bipolar Coagulation RoBi' = 50 W

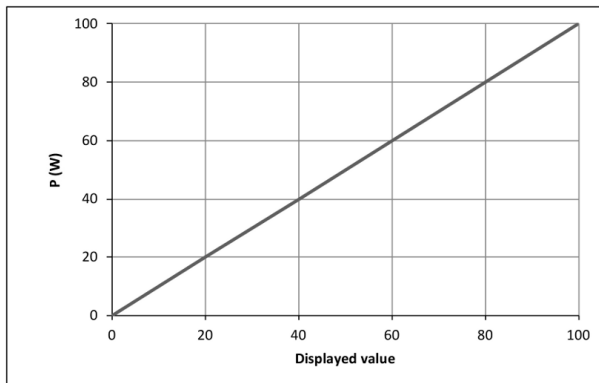

Diagram of power output P (W) as a function of the setting 'Bipolar Coagulation RoBi'. Rated load resistance = 25Ω

Measurement at ohmic resistances

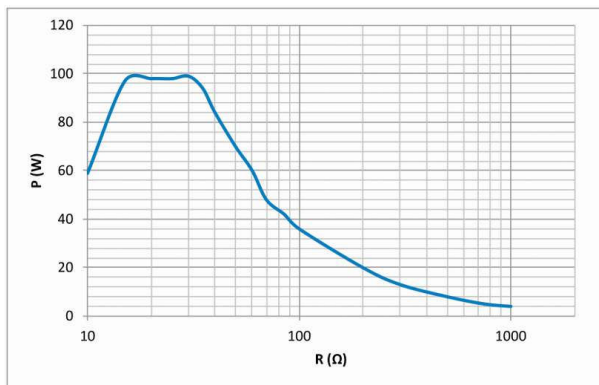

Diagram of power output P (W) as a function of the load resistance R (Ω) for the setting 'Bipolar Coagulation RoBi' = 100 W

HF output voltage U (Vp) with the setting 'Bipolar Coagulation RoBi' (idle mode) = 110 Vp

11.3.27 Bipolar Coagulation – Standard plus



Measurement at ohmic resistances

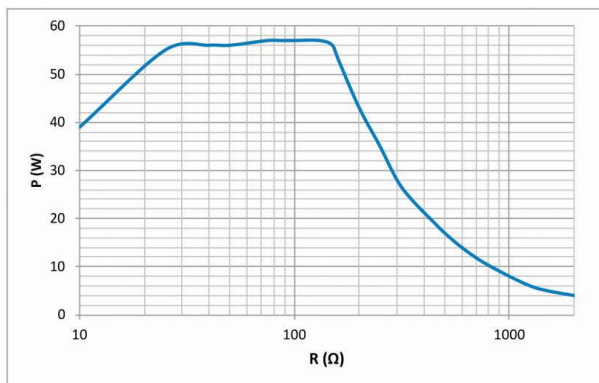

Diagram of power output P (W) as a function of the load resistance R (Ω) for the setting 'Bipolar Coagulation Standard plus' = 60 W

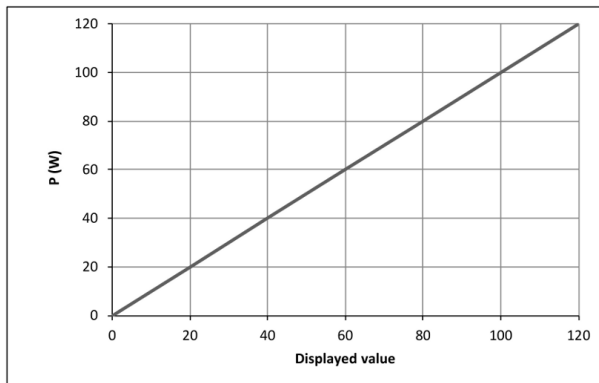

Diagram of power output P (W) as a function of the setting 'Bipolar Coagulation Standard plus'. Rated load resistance = 50Ω

Measurement at ohmic resistances

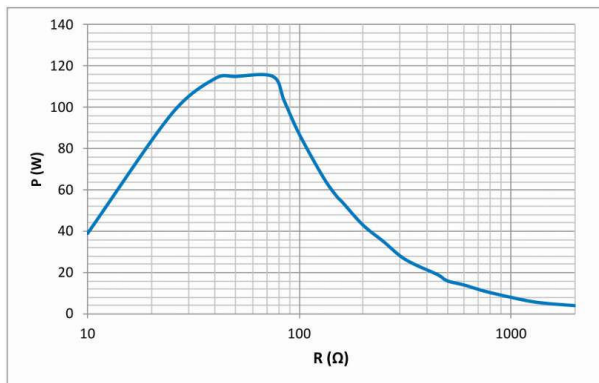

Diagram of power output P (W) as a function of the load resistance R (Ω) for the setting 'Bipolar Coagulation Standard plus' = 120 W

HF output voltage U (Vp) with the setting 'Bipolar Coagulation Standard plus' (idle mode) = 150 Vp

11.3.28 Bipolar Coagulation – Standard



Measurement at ohmic resistances

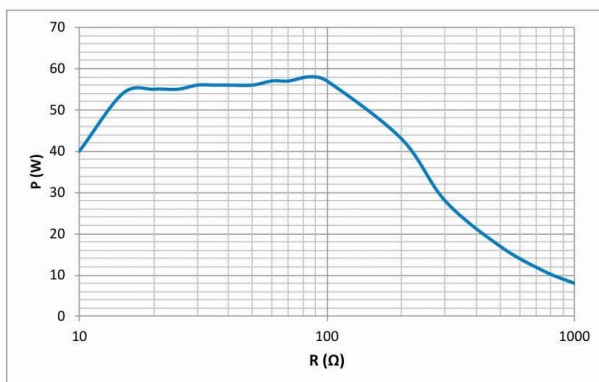

Diagram of power output P (W) as a function of the load resistance R (Ω) for the setting 'Bipolar Coagulation Standard' = 60 W

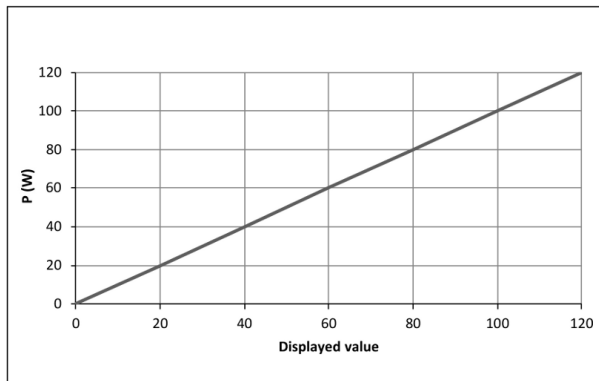

Diagram of power output P (W) as a function of the setting 'Bipolar Coagulation Standard'. Rated load resistance = 50Ω

Measurement at ohmic resistances

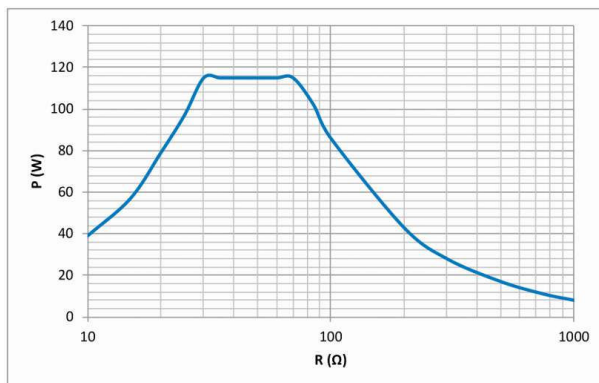

Diagram of power output P (W) as a function of the load resistance R (Ω) for the setting 'Bipolar Coagulation Standard' = 120 W

HF output voltage U (Vp) with the setting 'Bipolar Coagulation Standard' (idle mode) = 150 Vp

11.3.29 Bipolar Coagulation – Bip. Resection 15 Fr.



Measurement at ohmic resistances

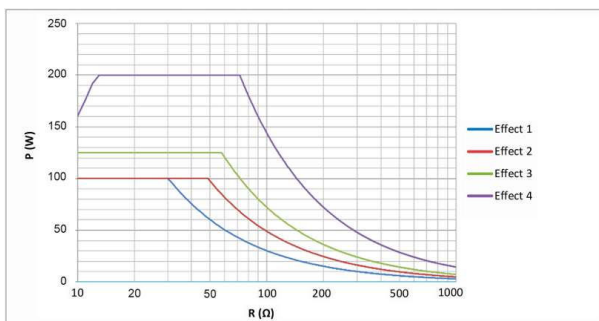

Diagram of power output P (W) as a function of the load resistance R (Ω) for the setting "Bipolar Coagulation Bip. Resection 15 Fr."

Effect	P (W)
1	100
2	100
3	125
4	200

Tab. 33: Table of power output P (W) as a function of the setting "Bipolar Coagulation Bip. Resection 15 Fr."

Rated load resistance = 25Ω

Effect	U (Vp)
1	110
2	130
3	160
4	220

Tab. 34: Table of HF output voltage U (Vp) as a function of the setting "Bipolar Coagulation Bip. Resection 15 Fr." (idle mode)

11.3.30 Bipolar Coagulation – Bip. Resection



Measurement at ohmic resistances

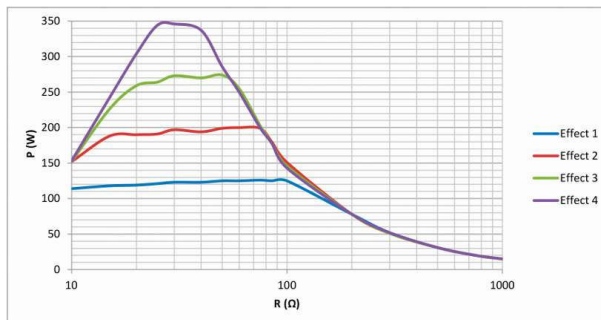

Diagram of power output P (W) as a function of the load resistance R (Ω) for the setting 'Bipolar Coagulation Bip. Resection' = 175 W

Effect	P (W)
1	125
2	300
3	275
4	350

Tab. 35: Table of power output P (W) as a function of the setting 'Bipolar Coagulation Bip. Resection'. Rated load resistance = 75Ω

Effect	U (Vp)
1	190
2	190
3	190
4	190

Tab. 36: Table of HF output voltage U (Vp) as a function of the setting 'Bipolar Coagulation Bip. Resection' (idle mode)

11.3.31 Bipolar Coagulation – Bip. Vaporization



Measurement at ohmic resistances

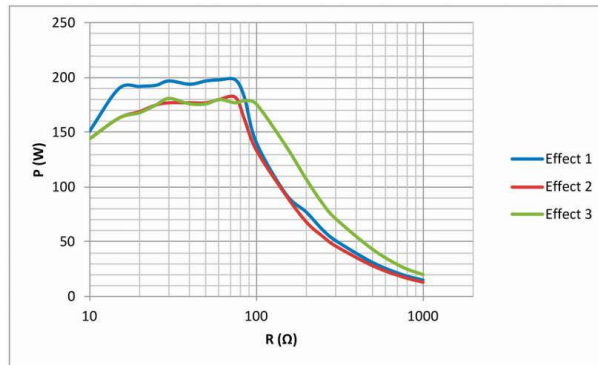

Diagram of power output P (W) as a function of the load resistance R (Ω) for the setting 'Bipolar Coagulation Bip. Vaporization'

Effect	P (W)
1	250
2	250
3	250

Tab. 37: Table of power output P (W) as a function of the setting 'Bipolar Coagulation Bip. Vaporization'.

Rated load resistance = 75 Ω

Effect	U (Vp)
1	190
2	400
3	500

Tab. 38: Table of HF output voltage U (Vp) as a function of the setting 'Bipolar Coagulation Bip. Vaporization' (idle mode)

11.3.32 Bipolar Coagulation – VAP COAG



Measurement at ohmic resistances

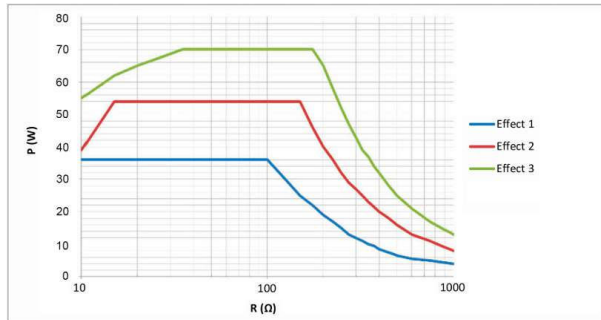

Diagram of power output P (W) as a function of the load resistance R (Ω) for the setting “Bipolar Coagulation Arthro VAP COAG”

Effect	P (W)
1	40
2	60
3	80

Tab. 39: Table of power output P (W) as a function of the setting “Bipolar Coagulation Arthro VAP COAG”.

Rated load resistance = 50 Ω (at effect 1 and 2)

Rated load resistance = 100 Ω (at effect 3)

Effect	U (Vp)
1	110
2	150
3	550

Tab. 40: Table of HF output voltage U (Vp) as a function of the setting “Bipolar Coagulation Arthro VAP COAG” (idle mode)

11.3.33 Bipolar Coagulation – Standard AUTO



Measurement at ohmic resistances

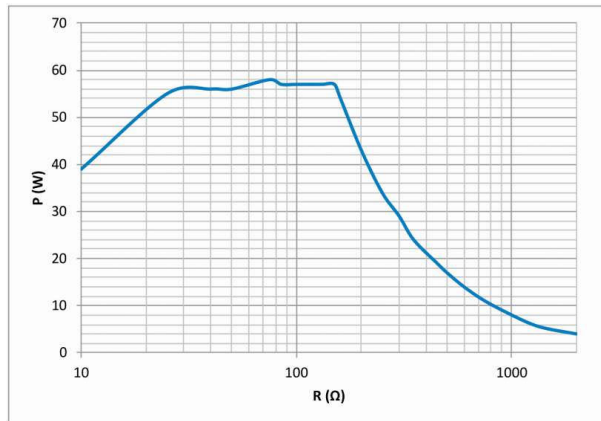

Diagram of power output P (W) as a function of the load resistance R (Ω) for the setting 'Bipolar Coagulation Standard AUTO' = 60 W

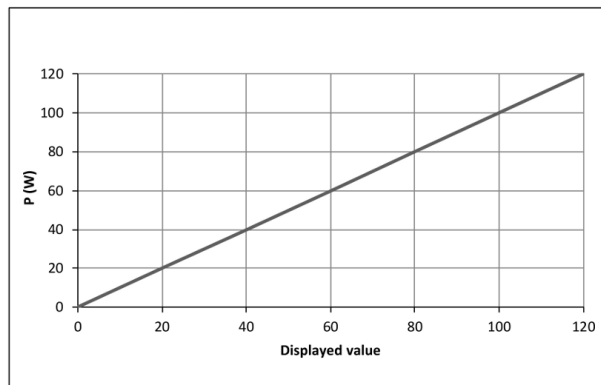

Diagram of power output P (W) as a function of the setting 'Bipolar Coagulation Standard AUTO'. Rated load resistance = 50 Ω

Measurement at ohmic resistances

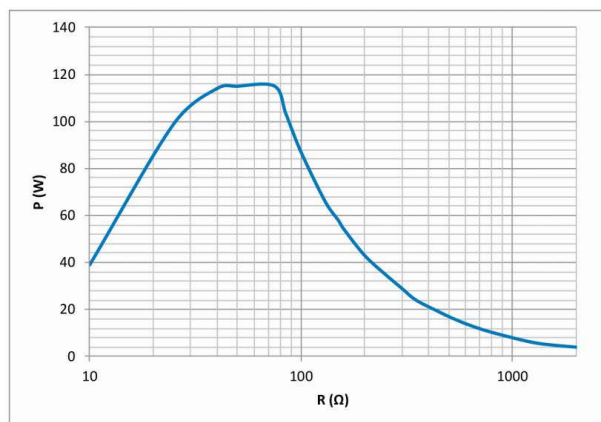

Diagram of power output P (W) as a function of the load resistance R (Ω) for the setting 'Bipolar Coagulation Standard AUTO' = 120 W

HF output voltage U (Vp) with the setting 'Bipolar Coagulation Standard AUTO' (idle mode) = 150 Vp

11.3.34 Bipolar Coagulation – Bipolar Scissors



Measurement at ohmic resistances

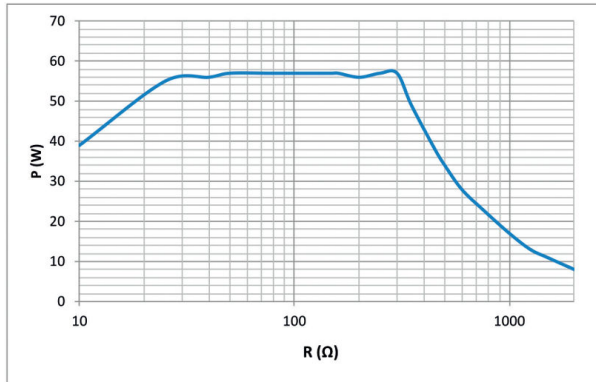

Diagram of power output P (W) as a function of the load resistance R (Ω) for the setting 'Bipolar Coagulation Bipolar Scissors' = 60 W

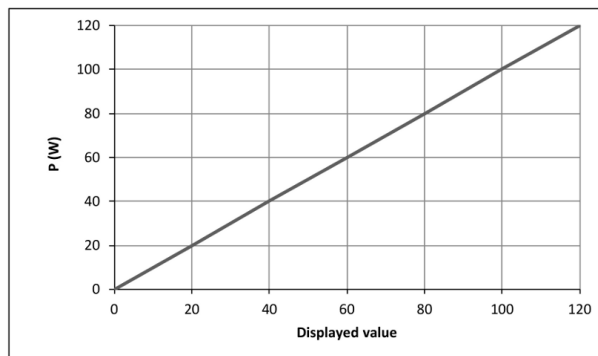

Diagram of power output P (W) as a function of the setting 'Bipolar Coagulation Bipolar Scissors'. Rated load resistance = 75 Ω

Measurement at ohmic resistances

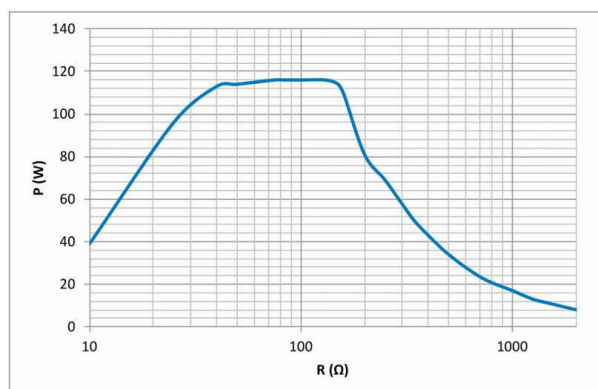

Diagram of power output P (W) as a function of the load resistance R (Ω) for the setting 'Bipolar Coagulation Bipolar Scissors' = 120 W

HF output voltage U (Vp) with the setting 'Bipolar Coagulation Bipolar Scissors' (idle mode) = 200 Vp

11.3.35 Bipolar Coagulation – Micro



Measurement at ohmic resistances

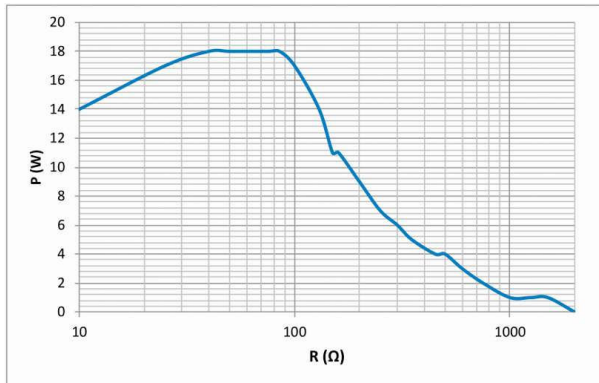

Diagram of power output P (W) as a function of the load resistance R (Ω) for the setting 'Bipolar Coagulation Micro' = 10 W

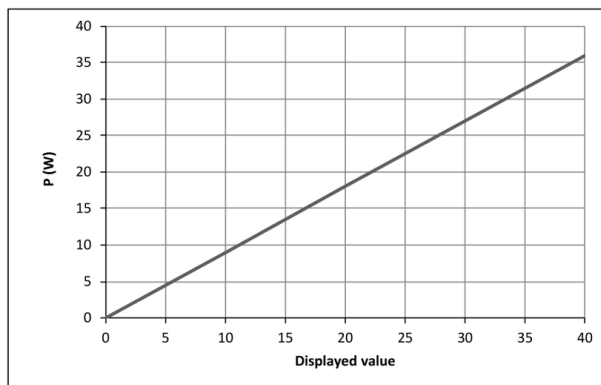

Diagram of power output P (W) as a function of the setting 'Bipolar Coagulation Micro'. Rated load resistance = 50 Ω

Measurement at ohmic resistances

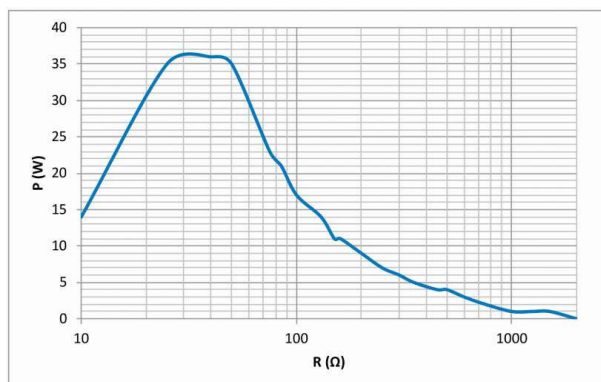

Diagram of power output P (W) as a function of the load resistance R (Ω) for the setting 'Bipolar Coagulation Micro' = 20 W

HF output voltage U (Vp) with the setting 'Bipolar Coagulation Micro' (idle mode) = 90 Vp

11.3.36 Bipolar Coagulation – Forced



Measurement at ohmic resistances

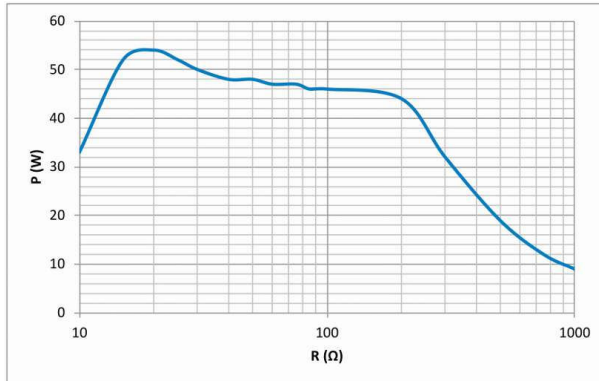

Diagram of power output P (W) as a function of the load resistance R (Ω) for the setting 'Bipolar Coagulation Forced' = 50 W

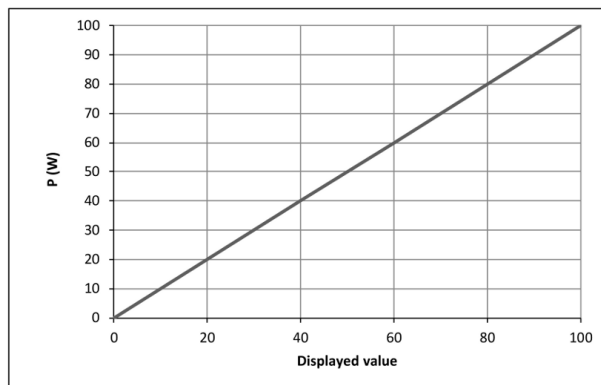

Diagram of power output P (W) as a function of the setting 'Bipolar Coagulation Forced'. Rated load resistance = 50 Ω

Measurement at ohmic resistances

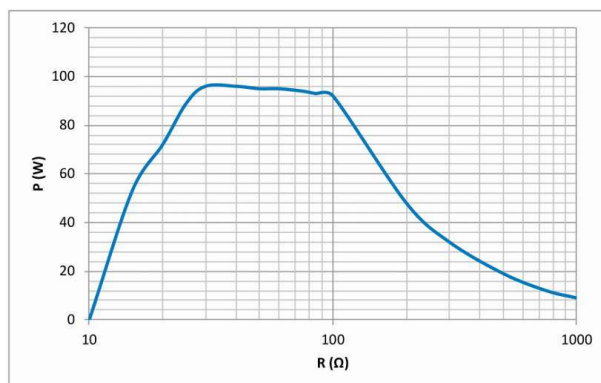

Diagram of power output P (W) as a function of the load resistance R (Ω) for the setting 'Bipolar Coagulation Forced' = 100 W

HF output voltage U (Vp) with the setting 'Bipolar Coagulation Forced' (idle mode) = 550 Vp

12 Subsidiaries

KARL STORZ SE & Co. KG

Dr.-Karl-Storz-Straße 34, 78532 Tuttlingen/Germany
Postfach 230, 78503 Tuttlingen/Germany
Phone: +49 7461 708-0, Fax: +49 7461 708-105
E-Mail: info@karlstorz.com

KARL STORZ Endoskope Berlin GmbH

Scharnhorststr. 3, 10115 Berlin/Germany
Phone: +49 30 30 69090, Fax: +49 30 30 19452

KARL STORZ Endoscopy Canada Ltd.

7171 Millcreek Drive, Mississauga, Ontario L5N 3R3 Canada
Phone: +1 905 816-4500, Fax: +1 905 816-4599
Toll free phone: 1-800-268-4880 (Canada only)
Toll free fax: 1-800-482-4198 (Canada only)
E-Mail: info-canada@karlstorz.com

KARL STORZ Endoscopy-America, Inc.

2151 East Grand Avenue, El Segundo, CA 90245-5017, USA
Phone: +1 424 218-8100, Fax: +1 424 218-8525
Toll free phone: 800 421-0837 (USA only)
Toll free fax: 800 321-1304 (USA only)
E-Mail: communications@ksea.com

KARL STORZ Veterinary Endoscopy-America, Inc.

1 South Los Cameros Road, Goleta, CA 93117, USA
Phone: +1 805 968-7776, Fax: +1 805 685-2588
E-Mail: info@karlstorzvet.com

KARL STORZ Endoscopia Latino-America, Inc.

815 N. W. 57th Avenue, Suite 480, Miami, FL 33126-2042, USA
Phone: +1 305 262-8980, Fax: +1 305 262-8986
E-Mail: info@ksela.com

KARL STORZ Endoscopia México S.A. de C.V.

Av. Ejercito Nacional No. 453 Piso 2, Colonia Granada, Alcaldia Miguel Hidalgo,
C.P. 11520 Ciudad de México
Phone: +52 (55) 1101 1520
E-Mail: mx-info@karlstorz.com

KARL STORZ Marketing América Do Sul Ltda.

Rua Joaquim Floriano, nº. 413, 20º andar – Itaim Bibi, CEP-04534-011 São Paulo,
Brasil
Phone: +55 11 3526-4600, Fax: +55 11 3526-4680
E-Mail: br-info@karlstorz.com

KARL STORZ Endoscopia Argentina S.A.

Zufriategui 627 6º Piso, B1638 CAA - Vicente Lopez, Provincia de Buenos Aires,
Argentina
Phone: +54 11 4718 0919, Fax: +54 11 4718 2773
E-Mail: info@karlstorz.com.ar

KARL STORZ Endoskopi Norge AS

Stamveien1, 1483 Hagan, Norway
Phone: +47 6380 5600, Fax: +47 6380 5601
E-Mail: post@karlstorz.no

KARL STORZ Endoskop Sverige AB

Storsåtragränd 14, 127 39 Skårholmen, Sweden
Phone: +46 8 505 648 00
E-Mail: kundservice@karlstorz.se

KARL STORZ Endoscopy Suomi OY

Taivaltie 5, 01610 Vantaa, Finland
Phone: +358 (0)96824774, Fax: +358 (0)968247755
E-Mail: asiakaspalvelu@karlstorz.fi

KARL STORZ SE & Co. KG

Representative Office
Žalgirio St. 94, LT9300 Vilnius, Lithuania
Phone: +370 5 272 0448, Mobile: +370 685 67 000
E-Mail: info-lt-lv@karlstorz.com

KARL STORZ Endoskopi Danmark A/S

Skovlytoften 33, 2840 Holte, Denmark
Phone: +45 45162600, Fax: +45 45162609
E-Mail: marketing@karlstorz.dk

KARL STORZ Endoscopy (UK) Ltd.

415 Perth Avenue, Slough, Berkshire, SL1 4TQ, United Kingdom
Phone: +44 1753 503500, Fax: +44 1753 578124
E-Mail: info-uk@karlstorz.com

KARL STORZ Endoscopia Nederland B. V.

Displayweg 2, 3821 BT Amersfoort, Netherlands
Phone: +31 (0)33 4545890
E-Mail: info-nl@karlstorz.com

KARL STORZ Endoscopy Belgium N. V.

Phone: +31 (0)33 4545890
E-Mail: info-be@karlstorz.com

KARL STORZ Endoscopia France S. A. S.

12, rue Georges Guynemer, Quartier de l'Europe, 78280 Guyancourt, France
Téléphone: +33 1 30484200, Fax: +33 1 30484201
E-Mail: marketing-fr@karlstorz.com

KARL STORZ Endoskop Austria GmbH

Landstraßer Hauptstr. 148/1/G1, 1030 Wien, Austria
Phone: +43 1 71 56 0470, Fax: +43 1 71 56 0479
E-Mail: storz-austria@karlstorz.com

KARL STORZ Endoscopia Ibérica S. A.

Parque Empresarial San Fernando, Edificio Munich – Planta Baja, 28830 Madrid,
Spain
Phone: +34 91 6771051, Fax: +34 91 6772981
E-Mail: info-es@karlstorz.com

KARL STORZ Endoscopia Italia S. r. l.

Via dell'Artigianato, 3, 37135 Verona, Italy
Phone: +39 045 8222000, Fax: +39 045 8222001
E-Mail: info-ita@karlstorz.com

KARL STORZ Croatia d.o.o.

Capraška 6, 10000 Zagreb, Croatia
Phone: +385 1 6406 070, Fax: +385 1 6406 077
E-Mail: info-hrv@karlstorz.com

KARL STORZ Endoskopija d.o.o.

Cesta v Gorice 34b, 1000 Ljubljana, Slovenia
Phone: +386 1 620 5880, Fax: +386 1 620 5882
E-Mail: pisama@karlstorz.si

KARL STORZ Polska Sp. z o.o.

ul. Holubcowa 123, 02-854 Warszawa, Poland
Phone: +48 22 2458 200, Fax: +48 22 2458 201
E-Mail: info-pl@karlstorz.com

KARL STORZ Endoszkóp Magyarország Kft.

Toberek utca 2. fsz. 17/b, HU-1112 Budapest, Hungary
Phone: +36 195 096 31, Fax: +36 195 096 31
E-Mail: info-hu@karlstorz.com

KARL STORZ Endoscopia Romania srl

Str. Prof. Dr. Anton Colorian, nr. 74, Sector 4, 041393 Bukarest, Romania
Phone: +40 (0)31 4250800, Fax: +40 (0)31 4250801
E-Mail: info-ro@karlstorz.com

KARL STORZ Endoskope Greece M.E.P.E.*

Patriarhou Grigoriou E' 34, 54248 Thessaloniki, Greece
Phone: +30 2310 304868, Fax: +30 2310 304862
E-Mail: info-gr@karlstorz.com
*Repair & Service Subsidiary

KARL STORZ Industrial**

Gedik Is Merkezi B Blok, Kat 5, D 38-39, Bagdat Cad. No: 162, Maltepe Istanbul,
Turkey
Phone: +90 216 442 9500, Fax: +90 216 442 9030
**Sales for Industrial Endoscopy

000 KARL STORZ Endoscopy – WOSTOK

Derbenyevskaya nab. 7, building 4, 115114 Moscow, Russia
Phone: +7 495 983 02 40, Fax: +7 495 983 02 41
E-Mail: Info-ru@karlstorz.com

TOV LLC KARL STORZ Ukraine

Avenue Geroyiv Stalingrada Str. 2D, office 717 Kyiv, 04210/Ukraine
Phone: +38 095 000-895-0, +38-097-000-895-0, +38 073 000-895-0
E-Mail: marketing@karlstorz.com.ua

KARL STORZ SE & Co. KG Representation Office

Sabit Orudschow 1184, apt. 23, 1025 Baku, Azerbaijan
Phone: +99 450 613 30 60
E-Mail: info-az@karlstorz.com

KARL STORZ ENDOSKOPE – East Mediterranean and Gulf (Offshore) S.A.L.

Spark Tower 1st floor Charles Helou St., Horch Tabet – Sin El Fil, Beirut, Lebanon
Phone: +961 1 501105, Fax: +961 1 501950
E-Mail: info@karlstorz-emg.com

KARL STORZ Endoscopy (South Africa) (Pty) Ltd.

P.O. 6061, Roggebaai, 8012 Cape Town, South Africa
Phone: +27 21 417 2600, Fax: +27 21 421 5103
E-Mail: info@karlstorz.co.za

T00 KARL STORZ Endoscopy Kasachstan

Saryarka, 6, BC "Arman", off. 910, 010000 Astana, Republic of Kazakhstan
Phone: +7 7172 552-549, 552-788, Fax: -444
E-Mail: info@karlstorz.kz

KARL STORZ ENDOSKOPE East Mediterranean & Gulf (branch)

Building West Side 7A – Unit 7WA – 3008, Dubai Airport Free Zone, P.O. Box 54983, Dubai - United Arab Emirates
Phone: +971 (0)4 2958887, Fax: +971 (0)4 3205282
Service Hotline: +971 (0)4 3415882
E-Mail: info-gne@karlstorz-emg.com

KARL STORZ Endoscopy India Private Limited

11th Floor, Dr. Gopal Das Bhawan, 28, Barakhamba Road, New Delhi 110001, India
Phone: +91 11 4374 3000, Fax: +91 11 4374 3010
E-Mail: corporate@karlstorz.in

KARL STORZ SE & CO. KG

Interchange 21 Tower, Level 32, Unit 3230, 399 Sukhumvit Road, North Klontoe, Wattana, 10110 Bangkok, Thailand
Phone: +66 2 660 3669
E-Mail: info-th@karlstorz.com

KARL STORZ SE & Co. KG

Resident Representative Office
14th Floor, MPlaza Saigon, 39 Le Duan, District 1, Ho Chi Minh City, Vietnam
Phone: +84 28 3823 8000, Fax: +84 28 3823 8039
E-Mail: infovietnam@karlstorz.com

KARL STORZ Endoscopy China Ltd.

Room 2503-05, 25F AXA Tower, Landmark East, No. 100 How Ming Street, Kwun Tong, Kowloon, Hong Kong, People's Republic of China
Phone: +852 28 65 2411, Fax: +852 28 65 4114
E-Mail: inquiry@karlstorz.com.hk

KARL STORZ Endoscopy (Shanghai) Ltd., Beijing Branch

Room 1805-1807, Building B, 18F Beijing IFC, No. 8, Jianguomenwai Street, Chaoyang District, 100022, Beijing, People's Republic of China
Phone: +86 10 5638188, Fax: +86 10 5638199
E-Mail: info@karlstorz.com.cn

KARL STORZ Endoscopy (Shanghai) Ltd., Shanghai Branch

Room 701A Building 5 & Room 501 Building 7, No. 3000 Longdong Avenue, Pilot Free Trade Zone, 201203, Shanghai, People's Republic of China
Phone: +86 21 60339888, Fax: +86 21 60339808
E-Mail: info@karlstorz.com.cn

KARL STORZ Endoscopy (Shanghai) Ltd., Chengdu Branch

Room 803-805, 8F Jin Jiang International Building, No. 1 West Linjiang Road, Wuhou District, 610041, Chengdu, People's Republic of China
Phone: +86 28 86587977, Fax: +86 28 86587975
E-Mail: info@karlstorz.com.cn

KARL STORZ Endoscopy (Shanghai) Ltd., Shenyang Branch

Room 2001-2005, 20F N-MEDIA International Center, No. 167 Youth Avenue, Shenhe District, 110014, Shenyang, People's Republic of China
Phone: +86 24 23181118, Fax: +86 24 23181119
E-Mail: info@karlstorz.com.cn

KARL STORZ Endoscopy (Shanghai) Ltd., Guangzhou Branch

Room 02B & 03 & 04A, 35F Teem Tower, No. 208 Tianhe Road, Tianhe District, 510620, Guangzhou, People's Republic of China
Phone: +86 20 87321281, Fax: +86 20 87321286
E-Mail: info@karlstorz.com.cn

KARL STORZ Endoscopy Asia Marketing Pte Ltd.

No. 8 Commonwealth Lane #03-02, Singapore 149555, Singapore
Phone: +65 69229150, Fax: +65 69229155
E-Mail: infoasia@karlstorz.com

KARL STORZ Endoscopy Singapore Sales Pte Ltd

No. 8 Commonwealth Lane #03-02, Singapore 149555, Singapore
Phone: +65 69229150, Fax: +65 69229155
E-Mail: infoasia@karlstorz.com

KARL STORZ SE & Co. KG Representative Office Indonesia

Sinarmas MSIG Tower Level 37, Jl. Jend. Surdirman No. Kav. 21, Jakarta Selatan DKI Jakarta 12920
E-Mail: infoindonesia@karlstorz.com

KARL STORZ Endoscopy Korea Co. Ltd.

9F Hyowon-Building, 97, Jungdae-ro, Songpa-gu, 05719 Seoul, Korea
Phone: +82-70-4350-7474, Fax: +82-70-8277-3299
E-Mail: infokorea@karlstorz.com

KARL STORZ Endoscopy Taiwan Ltd.

12F, No. 192, Sec. 2, Chung Hsin Rd., Sindian District, New Taipei City, Taiwan
Phone: +886 933 014 160, Fax: +886 2 8672 6399
E-Mail: info-tw@karlstorz.com

KARL STORZ Endoscopy Philippines Inc. Representative Office Philippines

1901 Picadilly Star Bldg., 4th Avenue, BGC, Taguig City 1636, Philippines
Phone: +63 2 317 45 00, Fax: +63 2 317 45 11
E-Mail: philippines@karlstorz.com

KARL STORZ Endoscopy Japan K. K.

Stage Bldg. 8F, 2-7-2 Fujimi, Chiyoda-ku, Tokyo 102-0071, Japan
Phone: +81 3 6380-8622, Fax: +81 3 6380-8633
E-Mail: info-jp@karlstorz.com

KARL STORZ Endoscopy New Zealand

Ltd. 31 Morningside Drive Mt Albert Auckland, 1025, New Zealand PO Box 56 511, Dominion Rd Auckland, 1446, New Zealand
Phone: +64 9 846 6044
Toll free: +64 508 84 84 84 (New Zealand only)
E-Mail: sales-nz@karlstorz.com

KARL STORZ Endoscopy Australia Pty. Ltd.

Suite 1, 68-72 Waterloo Road, Macquarie Park | NSW 2113, Australia, PO Box 50 Lane Cove | NSW 1595, Australia
Phone: +61 (0)2 9490 6700, Fax: +61 (0)2 9420 0695
Toll free: 1800 996 562 (Australia only)
E-Mail: karlstorz@karlstorz.com.au

KARL STORZ Endoscopy (UK) Limited

415 Perth Avenue, Slough, Berkshire, SL1 4TQ, United Kingdom
Phone: +44 (0)1753 503500
E-Mail: info-uk@karlstorz.com

www.karlstorz.com

STORZ
KARL STORZ—ENDOSKOPE



FDD675 • EN • V1.1 • 04-2025 • IFU • CE-MDR



KARL STORZ SE & Co. KG

Dr.-Karl-Storz-Straße 34
78532 Tuttlingen

Postfach 230
78503 Tuttlingen
Germany

Phone: +49 7461 708-0
Fax: +49 7461 708-105
E-mail: info@karlstorz.com
www.karlstorz.com

