

RESILIENT SEATED GATE VALVE

FAF 6000



Features

- 100% tight sealing is achieved through EPDM covered wedge fully contacting the fusion bonded epoxy coated flow surface.
- The body and bonnet are manufactured from ductile iron castings. It is resistant to high tensile stress occurring in pipelines.
- Low operating torque due to plastic sliding guides on the wedge
- Maintenance-free and corrosion-resistant stem sealing.
- With O-ring sealing.
- Up to DN 300 (inclusive) sizes are supplied with hand wheel as default DN 350 (inclusive) and above can be supplied with gear box as optional.
- Large conical stem hole in the wedge prevents stagnant water.
- Wedge and body guide rails ensure stable operation.
- Stainless steel stem with rolled threads for high strength & low operation torque.
- Inner and outer surfaces are coated with minimum 250 microns fusion bonded epoxy. 300 microns is available
- Suitable to use with aboveground and underground applications. Can be operated with actuator, gearbox, handwheel and extension spindle.
- The top of the shaft bearing and shaft nuts are made of MS58 brass. High precision machining enables low operation torques.
- Full bore characteristics without disruption of flow results in low pressure drops across the valve.

Temperature

- +130 °C (EPDM)

PRODUCTION STANDARTS

DN40 → DN800
PN 10-16-25

Design	EN 1171 / EN 1074
Connection	EN 1092-2 ISO7005-2 Flanged
Face to Face	EN 558 Series 14 DIN3202 F4
Marking	EN 19
Tests	EN 12266-1
Corrosion Protection	Electrostatic Powder Epoxy WRAS Approved (Optional)

Product Description

FAF6000 Resilient-seated gate valve with bolted cover connection; made of premium materials and with special coating designed as both clockwise (default) and anti-clockwise directions. (optinal)

Versions

- Standard version with handwheel
- Standard version without handwheel
- With ISO top flange and gearbox
- Ready for actuator connection
- With operation cap
- With top flange ready for actuator connection
- With electrical actuator

Accessories

- T-key, FAF7250T
- Telescopic extension spindle ST37 steel, FAF7250
- Rigid extension spindle
- Surface box cast iron, FAF7250K
- Flange adaptors, FAF3960
- Dismantling joints, FAF3900
- Handwheels

Scope of Application

- Pipelines
- Water treatment plants
- Pumping stations
- Tanks
- Seawater applications
- Power plants (cooling water pipelines)
- Industry
- Chlorine liquid application

RESILIENT SEATED GATE VALVE

FAF 6000

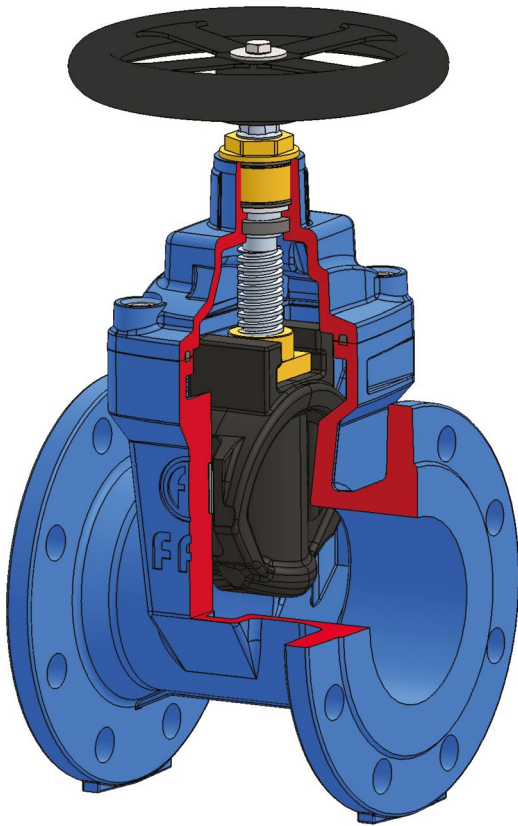

MATERIAL SELECTION

Body	EN-GJS-500 Ductile Iron / GGG50
Bonnet	EN-GJS-500 Ductile Iron / GGG50
Stem	1.4021 - AISI 420 Stainless Steel 1.4301 - AISI 304 Stainless Steel (Optional) 1.4401 - AISI 316 Stainless Steel (Optional)
Sealing	EPDM (Approved for potable water)
Coating	Electrostatic Powder Epoxy Approved For Drinking Water Min. 300 Microns (Optional)

PRODUCTS MODEL CODES

FAF6000	RESILIENT SEATED GATE VALVE - PN16
FAF6010	RESILIENT SEATED GATE VALVE - PN10
FAF6025	RESILIENT SEATED GATE VALVE - PN25
FAF6050	RESILIENT SEATED GATE VALVE - BS 5163

VALVE TEST PRESSURE (Bar)

MAX. OPERATING PRESSURE	BODY / SHELL TEST	SEAT TEST
10	15	11
16	24	17,6
25	37,5	27,5

100% of the valves are subjected to hydrostatic tests at FAF facilities.

Note

- For proper use and safety precautions please follow the installation and operating instructions.

Material List

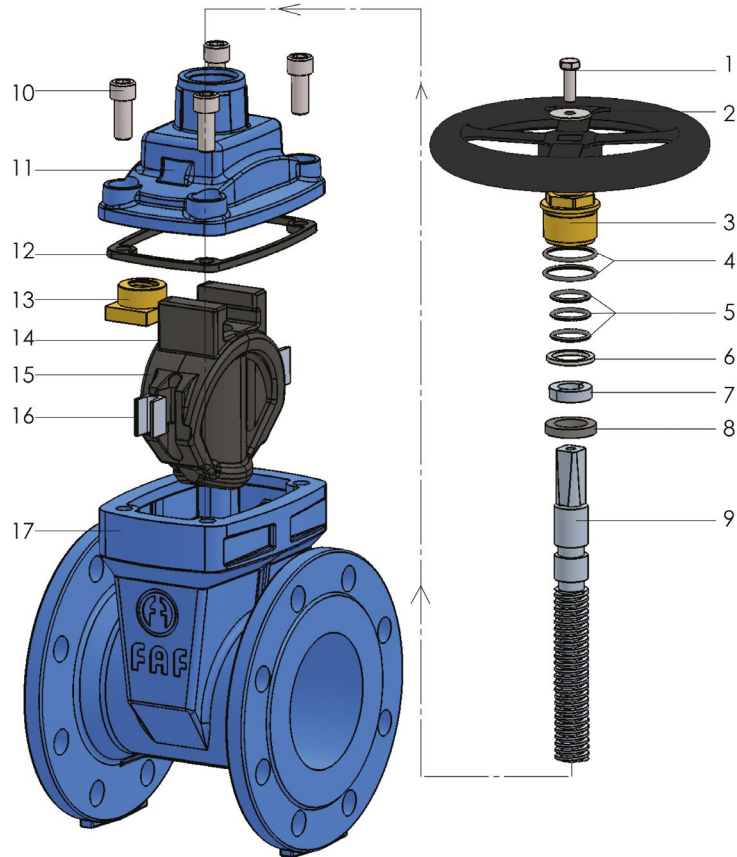

NO	ITEM	MATERIALS
1	BOLT	DIN 933 A2/A4
2	WASHER	STEEL
3	SHAFT NUT	CUZN40PB2 BRASS
4	O-RING	NBR/EPDM
5	O-RING	NBR/EPDM
6	WASHER	PTFE
7	WASHER	STEEL
8	NUTRING	EPDM
9	DRIVE SHAFT	AISI 420/304/316/316L
10	IMBUS BOLT	DIN 912 A2/A4
11	COVER	EN GJS 500 DUCTILE
12	COVER GASKET	EPDM
13	SLIDE NUT	CUZN40PB2 BRASS
14	WEDGE TOP	EPDM / NBR
15	WEDGE	EN GJS 500 DUCTILE
16	WEDGE GUIDE	POLYMER
17	BODY	EN GJS 500 DUCTILE

Technical Details & Drawing, Dimensions

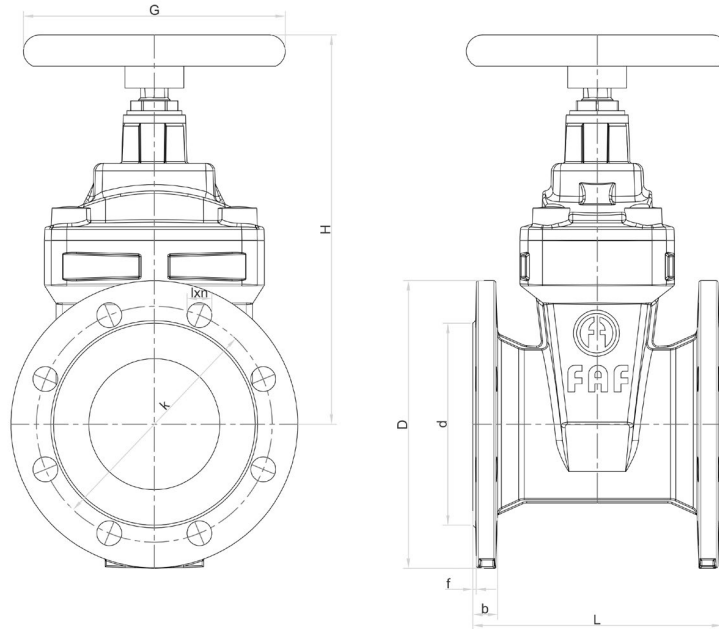

DN (mm)	PN	D	L	H	Kv (m ³ /h)	Torque (Nm)	f	b	G	d	k	Ølxn	WEIGHT (kg)
40	10/16	150	140	210	140	21	3	19	160	84	110	4XØ19	8,4
50	10/16	165	150	230	220	23	3	19	160	99	125	4XØ19	8,6
65	10/16	185	170	265	370	30	3	19	180	118	145	4XØ19	11,5
80	10/16	200	180	285	560	38	3	19	200	132	160	8XØ19	13,5
100	10/16	220	190	325	880	55	3	19	200	156	180	8XØ19	18,5
125	10/16	250	200	350	1380	55	3	19	250	184	210	8XØ19	24,1
150	10/16	285	210	390	2300	53	3	19	250	211	240	8XØ23	31,7
200	10	340	230	500	4090	88	4	20	320	266	295	8XØ23	51,2
	16	340	230	500	4090	91	4	20	320	266	295	12XØ23	51,2
250	10	400	250	595	6390	100	4	22	350	319	350	12XØ23	94,8
	16	400	250	595	6390	115	4	22	350	319	355	12XØ28	93,3
300	10	455	270	675	9200	100	4	24,5	350	370	400	12XØ23	122,1
	16	455	270	675	9200	115	4	24,5	350	370	410	12XØ28	120,5
350	10	505	290	785	11370	100	4	24,5	450	429	460	16XØ23	190
	16	520	290	785	11370	132	4	26,5	450	429	470	16XØ28	190,4
350 - gear box*	10	505	290	785	11370	27	4	24,5	450	429	460	16XØ28	210
	16	520	290	785	11370	47	4	26,5	450	429	470	16XØ28	210
400	10	565	310	900	16350	90	4	24,5	500	480	515	16XØ28	248,2
	16	580	310	900	16350	130	4	28	500	480	525	16XØ31	230,1
400 - gear box*	10	565	310	900	16350	29	4	24,5	500	480	515	16XØ28	270
	16	580	310	900	16350	46	4	28	500	480	525	16XØ31	255
500	10	670	350	1000	25560	114	4	26,5	600	582	620	20XØ28	412
	16	715	350	1000	25560	144	4	31,5	600	609	650	20XØ34	412
500 - gear box*	10	670	350	1000	25560	25	4	26,5	600	582	620	20XØ28	447
	16	715	350	1000	25560	48	4	31,5	600	609	650	20XØ34	447
600	10	780	390	1200	37000	660	5	30	600	682	725	20XØ31	613
	16	840	390	1200	37000	720	5	36	600	720	770	20XØ37	620
600 - gear box*	10	780	390	1200	37000	89	5	30	600	682	725	20XØ31	648
	16	840	390	1200	37000	118	5	36	600	720	770	20XØ37	655

RESILIENT SEATED GATE VALVE

FAF 6000

Advantages of Resilient Seated Gate Valves

Resilient-seated gate valves are used for reliable and safe supply of hot&cold water, potable water, waste water management, and also for the supply of fire water.

Compared to metal seated gate valves, resilient seated gate valves have many advantages.

The body is relatively simple, the good casting process for a wide range. The sealing performance is very good, so that the sealing surface is less eroded when it's full open. Resilient-seated gate valves have good shutoff characteristics and bidirectional. The pressure loss through the valve is minimal.

Lighter, more durable, reduced carbon footprint.

Safety Manual for Maintenance, Inspection and Installation Works

For the trouble-free usage of resilient seated gate valves, this manual should be reviewed carefully and information supplied should be applied continuously.

Not following the safety instructions will cause below issues.

- Personal injuries,
- Danger for both environment and valve,
- Malfunction of the major valve / facility functions,
- Failure of the projected maintenance and repair applications,
- Danger to people connected to electrical, mechanical and chemical effects.
- Damage to the environment caused by dangerous leakage.

No modifications or changes can be made to the products supplied by FAF Valve Company. FAF Valve Company shall not be liable for any damage or damages that may result from the failure to comply with the information given in this manual or modification without prior authorization.

Installation, use and maintenance of the gate valves should be done with professionally trained people. Although all FAF VALVE products are manufactured in accordance with international regulations and standards, valves are potentially hazardous if not used properly or used for purposes other than their intended use. All responsible personnel for the storage, installation, use, maintenance and disassembly of the valves should carefully read and well understand this document. All international and local safety instructions must be reviewed and understood before taking any action on the valve or pipeline. All necessary precautions must be taken.

If any repairs are to be made, there should be no pressure on the pipeline, and if necessary, all fluid should be drained and warning signs should be placed around the working area.

Devices that can be remotely controlled, such as actuators should be switched to off position. Precautions should be taken to prevent operation of those kind of devices working with stored energy such as compressed air, pressurized water, hydraulic uninterruptible power supply, etc. If a drain valve is to be repaired or uninstalled, precautions must be taken to ensure that the working zone is suddenly filled with water.

The use of original spare parts will ensure the operational safety of the products. The manufacturer can not be held responsible for damage caused by use of non-original parts or accessories.

If a valve needs to be removed, the pipeline should be discharged. The necessary precautions should be taken due to the remaining fluid which will flow freely after the valve has been removed.

Avoid sudden movements during the lifting, moving and lowering of the valve. Sudden movements may damage the valve and/or lifting equipment. The lifting must only be done from the lifting lugs located on the body.

The valve may move involuntarily aside during the lifting operation with a crane. Lifting by crane should be done by a specialist personnel and no one other than the operator should enter the working area during the operation.

Any operation on the actuated valve can be done after the actuator has been removed from the power supply. The procedure described in the operating instructions must be followed to switch off the actuator.



Operating Instructions

Inspection On Delivery

1. Check for possible damage in shipment, conformance to specifications, opening direction, shortages, etc.
2. Carefully unload all valves - do not drop valve - do not lift valve using gearing, bypass or other appendage as a hook.
3. Valve should be opened and then closed to make sure it works properly. Also check opening direction against the order instruction.
4. Any problems should be reported immediately to delivery company and note on bill of lading, signed by the driver on customer's copy.

Inspection Before Installation

1. Check to see the valve end-joints are clean.
2. The valve should not be damaged.
3. Open and close valve - make sure it works properly.
4. Keep valve closed when placing in trench.
5. Inspect casting for damage.
6. Inspect epoxy coating and repair breaks using compatible coating material.

Testing

1. Do not backfill valves before hydrostatic system test. Leave the valves exposed while the pipeline is being pressurized. Check to see that all valve joints and pressure containing bolting, including bonnet bolts, are tight.
2. Valves can be tested (but not operated) at 1,1 times the rated pressure of the valve.
3. After testing, steps should be taken to relieve any trapped pressure in body of valves.

Storage

1. Valves should be stored in a partially open position.
2. When possible, keep valves out of the weather.
3. In cold climates the inside of the valve must be kept drained of any water to prevent freezing.
4. When stored outside, valve stem should be in a vertical position, and whenever possible, valves should be covered with a water-proof covering.
5. Protect all parts of the valve at all times.
6. Protect rubber seat of resilient wedge valves from ozone and hydrocarbons (solvents, paints and oils, etc.).

Installation

1. Flush the water line completely.
2. Handle valve carefully.
3. Prepare pipe ends in accordance with pipe manufacturers' instructions.
4. Install valve using appropriate instructions for the specified joint (flanged, mechanical joint, slip-on, etc.).
5. Water piping should be properly supported to avoid line stress on valve.
6. In buried applications, make sure that the valve box does not transmit traffic loads or other stress to the valve.
7. Do not use valves to force a pipeline into position.
8. Do not deflect any valve/pipe joint.
9. Protect exterior epoxy coating during backfill.

Operation

The operation of a resilient wedge valve will "feel" different to the valve operator compared to an older style double-disc gate valve. In normal circumstances, less operating torque is required as the resilient wedge valve just closes, or on opening. Valve operators should be instructed to adhere to the 'number of turns to open' for the size of valve in question rather than rely only upon the feel of the valve

Associated Products for the Resilient Seated Gate Valve Range

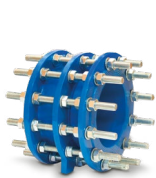

3900
DISMANTLING JOINT



7250
EXTENSION SPINDLE
SURFACE BOX



HANDWHEEL



STEM CAP



3800 BUTTERFLY
VALVE FLANGED
DOUBLE ECCENTRIC



2500
Y-TYPE STRAINER



2350
CHECK VALVE
DUAL



7330
DYNAMIC ARV



5000
RUBBER
EXPANSION JOINT



2270
CHECK VALVE
SWING



3960
FLANGE ADAPTOR



3970
COUPLING