

Specificatii tehnice

Numărul procedurii de achiziție 21591132 din 1.04.2026
Obiectul achiziției: Echipament pentru laboratorul de referință – Lot 7

Denumirea bunurilor	Denumirea modelului bunului	Țara de origine	Producătorul	Specificarea tehnică deplină solicitată de către autoritatea contractantă	Specificarea tehnică deplină propusă de către ofertant	Standarde de referință
1	2	3	4	5	6	7
Sistem de purificare a apei	Purelab Quest UV	Regatul Unit	Elga Veolia	<p>Producție de apă ultrapură (tip I) conform standardului ASTM D1193 și ISO 3696. Tehnologie avansată de purificare, care include osmoză inversă, deionizare și ultrafiltrare. Apa ultrapura (Tip I) Rezistivitate 18.2 MΩ.cm la temperatura de 25°C Debit de dozare: până la 1.2l/min; pH Neutru; Particule: 0.2μm Consum de apă zilnic pînă la 10l/zi. Intervalul de umplere al rezervorului în aproximativ 45 de minute. Timp de sanitizare aproximativ 1,5/H Apa ozmozată (Tip III) Conductivitate: <20 μS/cm; Respingere ionică >96%; respingere particule și bacterii >99% Debit producție 10l/h Consum de apă zilnic: pînă la 30l/zi</p>	<p>Producție de apă ultrapură (tip I) conform standardului ASTM D1193 și ISO 3696. Tehnologie avansată de purificare, care include osmoză inversă, deionizare și ultrafiltrare. Apa ultrapura (Tip I) Rezistivitate 18.2 MΩ.cm la temperatura de 25°C Debit de dozare: maxim 1.2l/min pH Neutru Particule: 0.2μm Consum de apă zilnic aprox. 10l/zi Apa osmozată (Tip III)</p>	<p>Pagina 1 din fisierul tehnic „Sistem de purificare a apei indice performanta” Pagina 1 și 2 din fisierul tehnic „Sistem de purificare a apei Quest UV”</p>

			<p>Mediu de lucru: Temperatura 4–40°C ; Umhiditate: Maxim 80% Consum de apa de retea: Apa de retea: pîna la 75L/hr; consum de apa de spalare> 90L/hr; Curent electric: 100-240VAC, 50–60Hz; Consum electric 120 VA; Zgomot dBA - <40;</p> <p>Inaltime intre 500-550mm; Lungime 230-250mm Montare pe masa de laborator. Cu cartuse corespunzatoare de purificare și osmoza inversă. Certificări: Echipamentul trebuie să fie marcat CE, în conformitate cu directivele europene aplicabile. Garanție: Certificat de garanție: minimum 24 luni de la data livrării. Instruire personal: Furnizorul va asigura instruirea personalului de operare timp de minimum 1 zi lucrătoare. Instruirea va fi realizată de către personal autorizat și calificat, cu experiență relevantă în utilizarea echipamentului. Manual de utilizare. Livrare inclusă</p>	<p>Conductivitate:<20 μS/cm Respingere ionica >96% Respingere particule si bacterii >99% Debit producție 10l/h Consum de apa zilnic: pîna la 30l/zi Mediu de lucru: Temperatura 4–40°C Umhiditate: Maxim 80% Consum de apa de retea: Apa de retea: pîna la 75L/ora Consum de apa de spălare> 90L/ora Curent electric: 100-240VAC, 50–60Hz Consum electric 120 VA Zgomot dBA - <40 Intervalul de umplere al rezervorului in aproximativ 45 de minute Timp de sanitizare: 1,5 ore Inaltime 511 mm Lungime 232 mm</p> <p>Echipamentul este potrivit pentru montaj atat pe masa de lucru, cat si pe perete dupa necesarul din laborator. Echipamentul este livrat complet cu un set de filtre. Certificări: Echipamentul este marcat CE, în conformitate cu directivele europene aplicabile. Garanție: Certificat de garanție: 24 luni de la data livrării. Instruire personal: Furnizorul va asigura instruirea personalului de operare timp de minimum 1 zi lucrătoare. Instruirea va fi realizată de către personal autorizat și calificat, cu experiență relevantă în utilizarea echipamentului. Documente insotitoare la livrare: factura fiscala, certificat de garantie, declaratie de calitate/conformitate emisa de catre firma producatoare, manual de utilizare in limba engleza.</p>	<p>Pagina 4 si 5 din fisierul tehnic „Sistem de purificare a apei Quest UV”</p> <p>Pagina 7 si 12 din fisierul tehnic „Manual de operare Quest”</p> <p>Pagina 5 din fisierul tehnic „Sistem de purificare a apei Quest UV”</p>
--	--	--	--	---	--

--	--	--	--	--	--	--

CONDITII DE LIVRARE SI PLATA:

Plata se efectueaza in MDL, in termen de 30 zile de la prezentarea facturii fiscale.

Pretul exprimat este fara TVA. Acesta include instalarea si punerea in functiune a echipamentului, precum si instruirea personalului utilizator.

Livrarea se efectueaza in termen de 90 zile de la data comenzii / semnarii contractului de catre ambele parti.

Receptia calitativa si cantitativa se efectueaza la sediul beneficiarului.

Instalarea, punerea in functiune a echipamentului, precum si instruirea personalului utilizator sunt efectuate de catre personal specializat.

Garantia echipamentul este de 24 luni de la data livrarii, in conditiile respectarii recomandarilor de utilizare si intretinere date de producator.

Service-ul in garantie este asigurat de catre O.F. SYSTEMS SRL prin personal specializat.

Service-ul este asigurat la locul de functionare a echipamentului.

In cazul in care echipamentul, din considerente obiective nu poate fi reparat pe loc, acesta va fi depanat la sediul societatii noastre, cheltuielile de transport si asistenta tehnica fiind suportate de catre firma furnizoare.

Service-ul postgarantie este asigurat in aceleasi conditii ca cele specificate in paragraful anterior, in baza unui contract de service postgarantie.

Documente insotitoare: factura fiscala, certificat de garantie, declaratie de calitate/conformitate emisa de catre firma producatoare, manual de utilizare in limba engleza.

Valabilitate oferta: 60 zile.

Semnat:

Numele, Prenumele: Andrei S. Patasanu

Ofertantul: SC OF SYSTEMS SRL

Adresa: Str. M. Kogalniceanu 66, of 4, mun. Chisinau, Republica Moldova



PURELAB[®] Quest

Technical Specification

The perfect solution for all your laboratory needs

PURELAB® Quest offers you the most advanced, affordable water specification available today, delivering all three types of lab water directly from tap water input.

The Complete Water Specification

Whether you require ultrapure (Type I) water for high performance liquid chromatography (HPLC) & molecular biology techniques; pure water (Type II) for media preparation & general chemistry or RO (Type III) water for glassware washing & autoclaves; PURELAB Quest dispenses water for the widest range of applications in a single elegant system.

Reliable

PURELAB Quest has multiple quality sensors to constantly monitor both ultrapure and pure water; inbuilt periodic recirculation to minimise biofilm build up and optional point of use filters. It uses tried and tested core components from over a decade of user experience and has been robotically tested to achieve more than 150,000 dispensing cycles.

Space Saving Design

Measuring at only 232mm in width, the compact design can be wall mounted or placed on a bench to easily fit into any laboratory - optimising valuable lab space.

Reduced Environmental Impact

PURELAB Quest is made from more than 85%* reclaimed materials. It is designed to reduce the environmental impact of your laboratory.

Simple

PURELAB Quest is simple to install, operate and has a pre-programmed annual sanitisation process to minimize downtime.

Data Capture

With PURELAB Quest, data capture is via a USB port which is useful for capturing water parameters, software updates & diagnosing certain faults/issues. Quest is also IOT enabled with **AQUAVISTA** from Veolia.

Flow process PURELAB® Quest UV

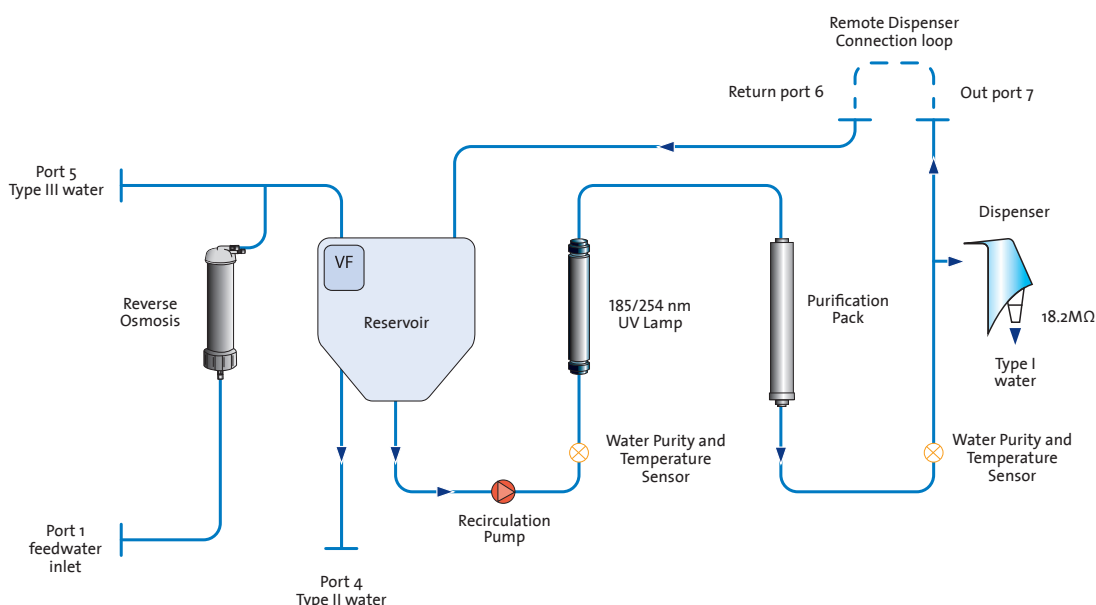

* Materials not in contact with purification process



Type I, II & III Water

KEY FEATURES

- Tap to Ultrapure, Pure & RO water
- Multiple water purity sensors
- Fully recirculating
- 232mm in width
- Bench top or wall mounted
- Data Capture and IoT with AQUAVISTA from Veolia

IDEALLY SUITED FOR :

- Liquid Chromatography
- Mass Spectrometry
- Atomic Spectroscopy
- Molecular Biology
- Immunochemistry
- Media/Buffer preparation
- Autoclaves
- Washing / Rinsing
- Hydroponics



Water Specification

International conformity

Technical Specifications	PURELAB® Quest UV	PURELAB® Quest
Ultrapure (Type I) water specifications (from fixed dispense point)		
Resistivity	18.2 MΩ.cm @ 25°C	18.2 MΩ.cm @ 25°C
Dispense flow rate	Up to 1.2l/min	Up to 1.2l/min
TOC	<5 ppb	<30 ppb
Bacterial TVC	<0.1 cfu/ml*1	<0.1 cfu/ml*1
Endotoxin	<0.001 EU/ml*2	<0.001 EU/ml*2
RNases	<1pg/ml	N/A
DNases	<5pg/ml	N/A
pH	Effectively Neutral	Effectively Neutral
Particulates	0.2µm filtration*1	0.2µm filtration*1
Recommended daily volume	Up to 10l/day*3	Up to 10l/day*3
Pure (Type II) water specifications (Outlet port 4)		
Resistivity	> 1 MΩ.cm @ 25°C	> 1 MΩ.cm @ 25°C
TOC	<50 pbb	<50 pbb
Bacterial TVC	<100 cfu/ml	<100 cfu/ml
Recommended daily volume	Up to 10 l/day*3	Up to 10 l/day*3

Water Specification

International conformity

Technical Specifications	PURELAB® Quest UV	PURELAB® Quest
RO-permeate (Type III) water specifications (Outlet Port 5)		
Conductivity	<20 µS/cm*4	<20 µS/cm*4
TOC	<200 ppb*4	<200 ppb*4
Bacterial TVC	<1000 cfu/ml*4	<1000 cfu/ml*4
Ionic rejection	>96%*5	>96%*5
Particulates and Bacteria rejection	>99%	>99%
Organic rejection (MW > 200 Da)	>99%	>99%
Production flow	10l/hr*5	10l/hr*5
Daily volume	Up to 30l/ day	Up to 30l/ day

Feedwater Specifications	
Water Source	(Potable Water Source)
Conductivity	<2000 µS/cm (High conductivity feedwaters may lower purification pack life and raise Type III water conductivity)
Hardness	<350 ppm as CaCO ₃
Free Chlorine	<0.05 ppm Cl ₂
Chloramine	<0.02 ppm Cl ₂
Total Chlorine	<0.05 ppm Cl ₂
Silica	<30 ppm SiO ₂
Carbon Dioxide (CO ₂)	<30 ppm (Recommended <20 ppm)
Fouling Index	<10
Iron/Manganese	<0.5 ppm Fe/Mn
TOC (Total Organic Carbon)	Recommended <2ppm

Environment	
Temperature	4–40°C (Recommended 10–25°C)
Humidity	Non-condensating. Humidity Max 80%
Surroundings	Clean laboratory environment

*1 When using point of use filters (LC134/LC145/LC197)

*2 When using point of use filter(LC197)

*3 Available volume of Type I and II water combined; increased use will reduce purification pack life

*4 Subject to suitable feedwater purity (see ionic rejection) and system maintenance

*5 With feedwater pressure at > 4 bar and temperature at 15°C

Feedwater Pressure and Flow Rates

Feedwater Flowrate	Up to 75L/hr
Mains Drain Requirements	> 90L/hr
Minimum Inlet Pressure	2 bar (30 psi)
Maximum Inlet Pressure	6 bar (30 psi)
Optimum Inlet Pressure	Regulate to 4 bar (LA512)

Pipe Connections

Inlet	8mm (5/16) OD Tube
Outlet	8mm (5/16) OD Tube
Drain	8mm (5/16) OD tube
Reservoir Outlets	8mm (5/16) OD tube
Reservoir Overflows	8mm (5/16) OD tube

Technical Specifications	PURELAB® Quest UV	PURELAB® Quest
--------------------------	-------------------	----------------

Electrical Requirements

Main Input	100-240VAC, 50–60Hz	100-240VAC, 50–60Hz
Power Required	24 V DC	24 V DC
Power Consumption	120 VA	120 VA
Noise Output	dBA - <40	dBA - <40

Installation

Worktop	✓	✓
Wall-mounted	✓	✓

Dimensions and Weights

Dispatch Weight	19.6kg	18.5kg
Operational Weight	23kg	21.4kg
Dimensions	Height 511mm (20.1") Weight 232mm (9.133") Depth 421mm (16.57")	Height 511mm (20.1") Weight 232mm (9.133") Depth 421mm (16.57")

Dedicated to Discovery

info@elgalabwater.com / www.elgalabwater.com

ELGA Labwater are specialists in the engineering, service & support of water purification systems.

Unrivalled product design has achieved international recognition and awards.

Worldwide technical service teams support science & healthcare globally with specialist expertise.

Global digital performance monitoring from Hubgrade ensures laboratory work is uninterrupted.

A global supply chain supports clients from regional centres on every continent.

To find your nearest ELGA representative, go to www.elgalabwater.com and select your country for contact details.

Elga Global Operations Centre.

tel: +44 (0) 203 567 7300

fax: +44 (0) 203 567 7205



Hubgrade



OVER 70 INTERNATIONAL PATENTS

PURELAB Quest UV Performance Datasheet

Product Name: PURELAB Quest UV

Performance Test: Compliance of Type I water with water standards

Test description:

A PURELAB Quest UV was set up with a 30-litre 'external' reservoir, and fed with potable water (conductivity approx. 600 $\mu\text{S}/\text{cm}$, TOC approx. 700 ppbC) at 4 bar. The system was operated over a 3 month period and Type I and III product water was taken daily (10l and 30 l/day respectively) to simulate a typical usage pattern. Type 1 water resistivity and TOC were logged on-line using a Mettler Toledo M300 meter and a Sievers 900 TOC analyser, respectively. Samples were taken for biological testing; Total viable counts were measured after membrane filtration and incubation at 27°C for 5 days on R2A agar. Endotoxin determination was carried out with an Ati 320. Nitrate and Chloride were determined by ion chromatography, sodium by ICP-MS, and silica by colourimetry.

Parameter	Typical Measured Values for Type I Water	CLSI CLRW Specification	USP Purified Water Specification	EP Purified Water Specification
Conductivity ($\mu\text{S}/\text{cm}$ at 25°C)	down to 0.055	<0.1	<1.3	<5.1
TOC (ppb C)	2.8 - 4.3	<500	<500	<500
Bacteria (CFU/ml)	0.4 -1.9/<0.1*	<10	<100	<100
Particles	0.2 μm filtration*	0.22 μm stage	ns	ns
Nitrates (ppb)	<0.02	ns	ns	<200
Heavy Metals (as ppm Pb)	<0.1	ns	ns	<0.1

Parameter	Typical Measured Values for Type I Water	ISO Grade 1 Specification	ASTM Type IC Specification	ASTM Bio-applications Grade
Resistivity ($\text{M}\Omega\text{-cm}$ at 25°C)	up to 18.2	>10	>18	18.2
TOC (ppb C)	2.8 - 4.3	ns	<50	<20
Sodium (ppb)	<0.002	ns	<1	<1
Chloride (ppb)	<0.02	ns	<1	<1
Silica (ppb)	<1	<10	<3	ns
Bacteria (CFU/ml)	0.4-1.9/<0.1*	ns	<10	<1
Absorbance/cm at 254nm	<0.001	<0.001	ns	ns
Endotoxin (EU/ml)	<0.001	ns	ns	<0.01

Results:

Water from the unit met or exceeded the following standards:

- US Pharmacopoeia Purified Water Specification (USP 32, 1.1.2009.)
- European Pharmacopoeia Purified Water Specification (EP 6th Edition, 2009)
- ASTM Type IC Reagent Water Specification (ASTM D1193 - 06)
- CLSI CLRW Specification (CLSI C3-A4 (2006))
- BS3978/ISO 3696 Specification for "Water for laboratory use", Grade 1
- ASTM Bio-Applications Grade Water (ASTM D5196 - 06)

* Point-of-use filter fitted

Note: Final water quality is affected by many factors; feedwater quality, sample preparation techniques, analytical instrumentation techniques, models and settings, sample preparation methods and standard operating procedures together with the laboratory environment can all differ from one laboratory to another. The data and conclusions included in this document was obtained by ELGA R&D scientists and chemists under certain laboratory conditions and using specific equipment and defined laboratory protocols. Your results may vary depending on your actual experimental conditions, equipment and procedures.

PURELAB Quest UV Performance Datasheet

Product Name: PURELAB Quest UV

Performance Test: Commissioning Cycle

Test description:

Product water TOC and resistivity of a PURELAB Quest UV were recorded during installation of a new Quest purifier, to demonstrate the effectiveness of the process and time required for the unit to achieve high product water quality.

Experimental conditions and methods used:

The commissioning cycle of a new Quest I system was activated while monitoring TOC and resistivity of water at the dispense tap (Type I) and immediately after the recirculation pump (Type II). Mettler Toledo / Thornton conductivity equipment and GE Check-point analysers were used.

Results:

The purification process polished water to Type I and Type II quality quickly; All resistivity and TOC purity specifications were achieved after approximately 100 minutes of operating following starting the commissioning cycle. Resistivity and TOC specifications for Type I and Type II waters are respectively >18 and >1 MΩ.cm and <5 and <50 ppbC.

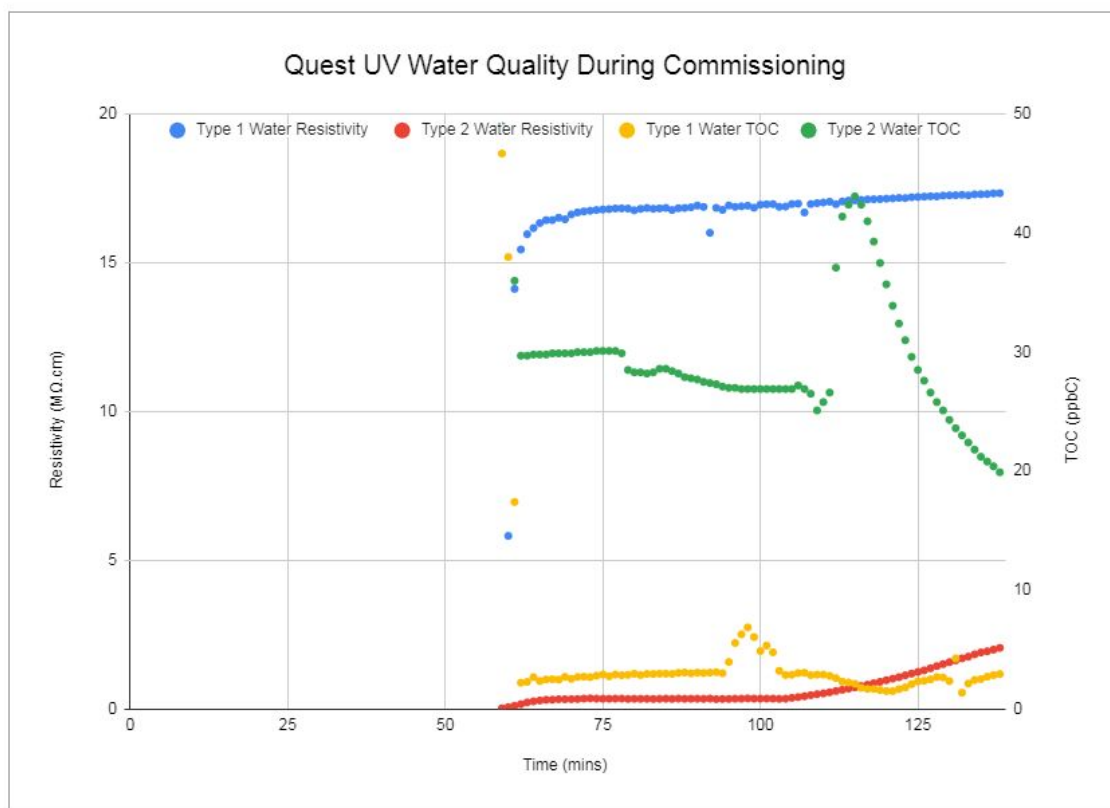

Commentary:

Installation of the Purelab Quest 1 is completed by an automated commissioning cycle that prepares the system for use. This cycle is included within the software and will automatically activate on supplying electrical power to a new Quest purifier.

Note: Final water quality is affected by many factors; feedwater quality, sample preparation techniques, analytical instrumentation techniques, models and settings, sample preparation methods and standard operating procedures together with the laboratory environment can all differ from one laboratory to another. The data and conclusions included in this document was obtained by ELGA R&D scientists and chemists under certain laboratory conditions and using specific equipment and defined laboratory protocols. Your results may vary depending on your actual experimental conditions, equipment and procedures.

PURELAB[®] Quest



Operator Manual

MANU41196 VERSION 02 2/20

Product No. PQDIUVM1

Product No. PQDIXXM1

WELCOME

Thank you for purchasing the PURELAB® QUEST. Please read the following Health and Safety notice before proceeding.

HEALTH & SAFETY

Please follow the safety information detailed in this instruction sheet. Failure to observe these instructions could result in damage to the equipment and associated equipment resulting injury or death.

1. Electricity

WARNING!
POSITION THE POWER SUPPLY SO THAT IT CANNOT COME INTO CONTACT WITH WATER.

2. Ultraviolet Light

WARNING!
UNDER NO CIRCUMSTANCES SHOULD THE LAMP BE CONNECTED AND ACTIVATED WHEN OUTSIDE THE UV HOUSING. EXPOSURE COULD CAUSE SERIOUS INJURY TO EYES AND SKIN.

3. Residual Preservative

WARNING!
DURING THE COMMISSIONING CYCLE TRACES OF RESIDUAL PRESERVATIVE ARE FLUSHED FROM THE SYSTEM. COSHH MATERIAL SAFETY DATA SHEET ARE AVAILABLE UPON REQUEST.

Control Of Substance Hazardous to Health (COSHH).

ELGA Veolia
Tel: +44 (0) 203 567 7300 Fax: +44 203 567 7205
Email: info@elgalabwater.com Website: www.elgalabwater.com
Unit 10 Lane End Industrial Park, Lane End, High Wycombe HP14 3BY

ELGA® is the global laboratory water brand name of Veolia. PURELAB is an ELGA trademark and technology. Owing to a policy of continual improvement, we reserve the right to amend the specifications given in this document. 2020 ELGA VEOLIA / VWS (UK) Ltd. All rights reserved.

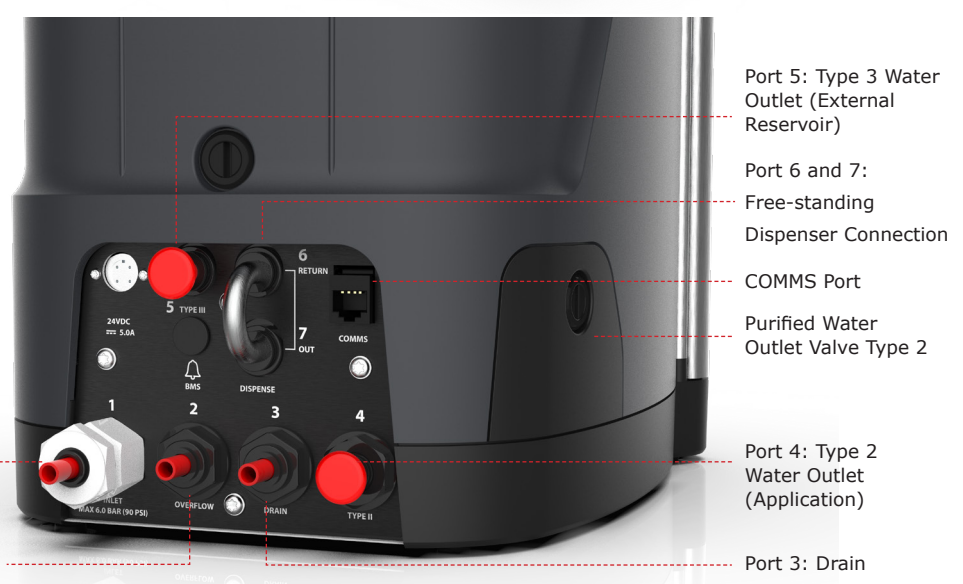

SYSTEM CONFIGURATION

Example 1: 1 X PURELAB[®] QUEST RO/DI/UV or RO/DI - Wall Mounting Bracket LA735 - LA648 Boost Pump

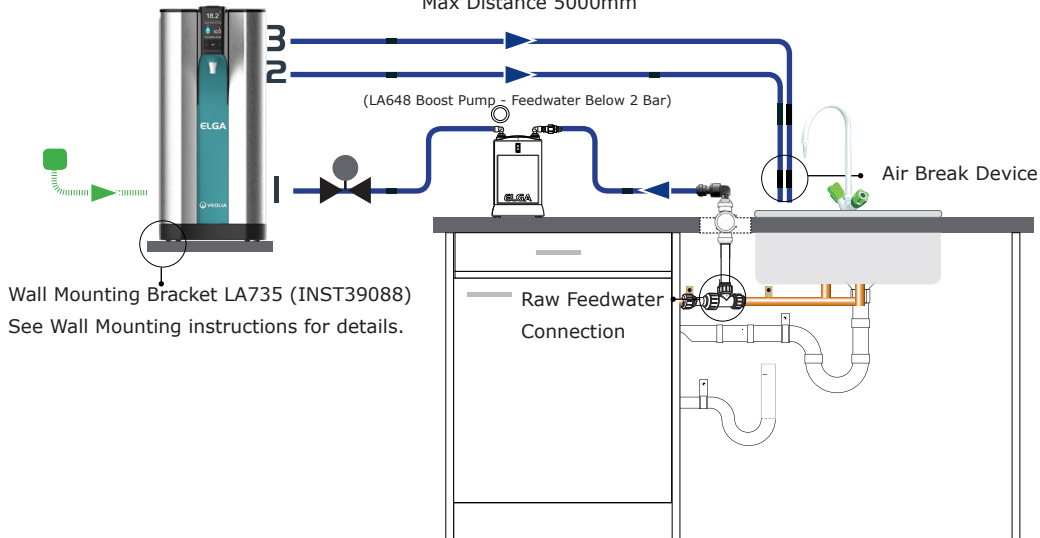

Key	
COMMS	
Power	
Water	
Valve	
Regulator LA512	
8mm Flow Bend	
8mm Tube Clip	

Quest Port 1: Feedwater
Quest Port 2: Overflow
Quest Port 3: Drain

Example 2: 1 X PURELAB[®] QUEST RO/DI/UV or RO/DI and 15L or 30L Reservoir LA757 / LA758.

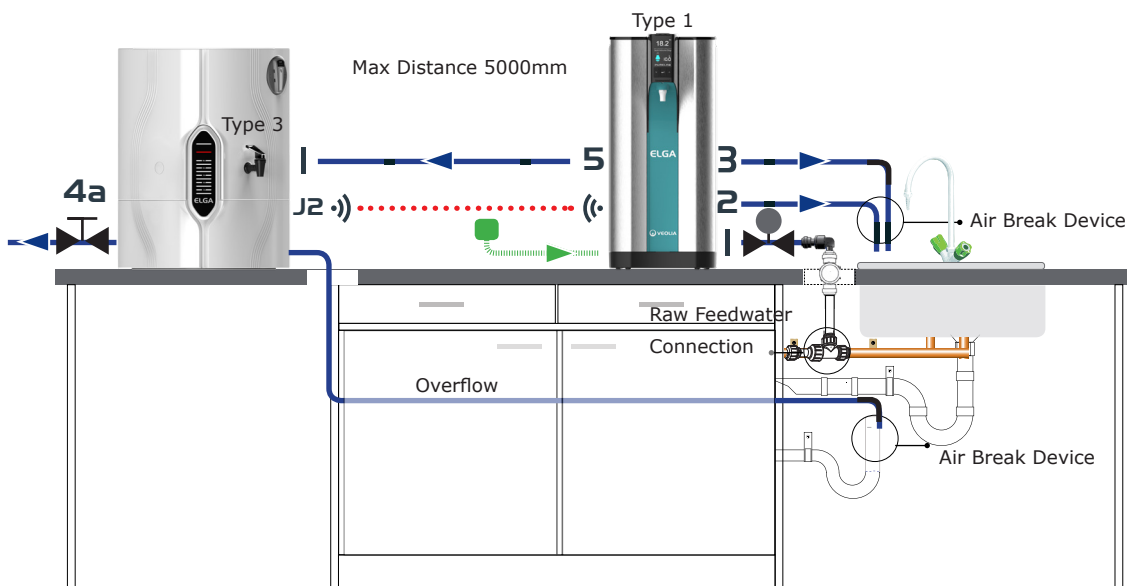

Quest Port 1: Feedwater
Quest Port 2: Overflow
Quest Port 3: Drain
Quest Port 5: Type 3 Outlet

Reservoir Port 1: Inlet
Reservoir Port 4a: Outlet
Reservoir Comms: J2

Example 3: 1 X PURELAB[®] QUEST RO/DI/UV or RO/DI and Free-standing Dispenser.

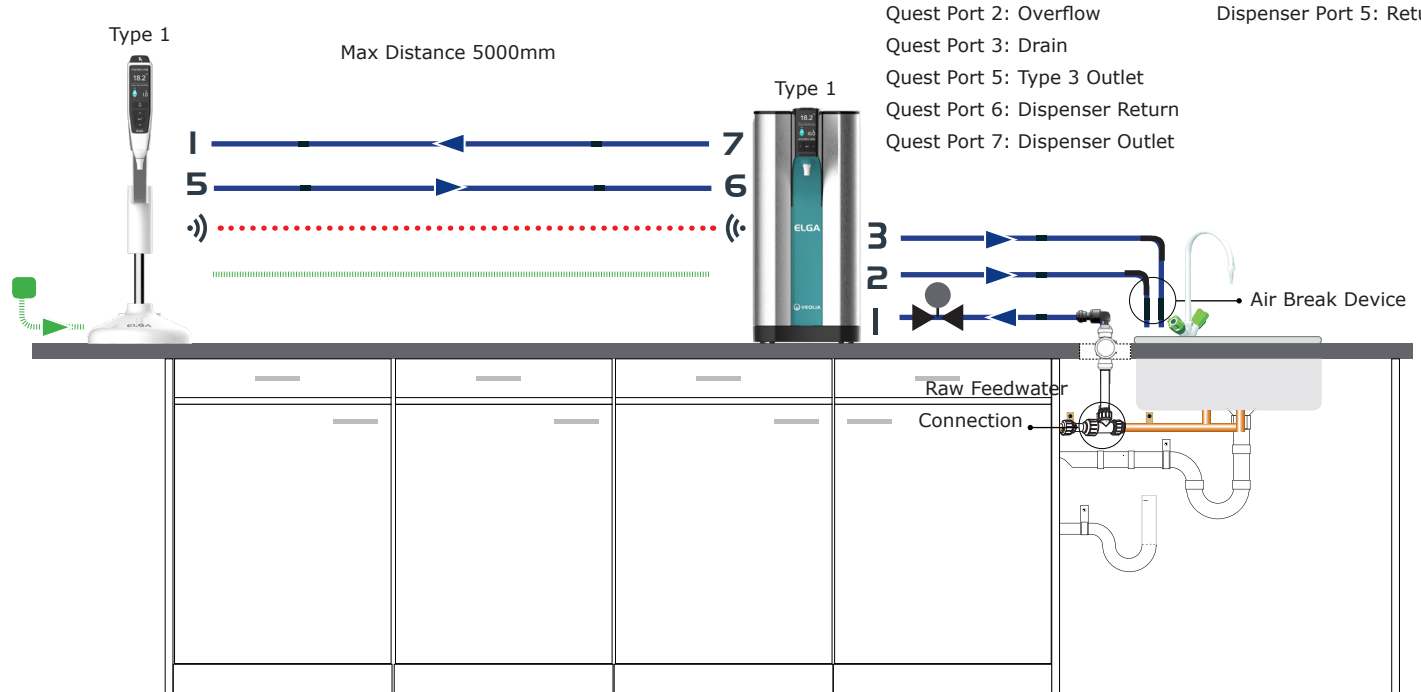

Quest Port 1: Feedwater
Quest Port 2: Overflow
Quest Port 3: Drain
Quest Port 5: Type 3 Outlet
Quest Port 6: Dispenser Return
Quest Port 7: Dispenser Outlet

Dispenser Port 1: Inlet
Dispenser Port 5: Return

SET - UP / COMMISSIONING

1 POSITIONING PURELAB[®] QUEST

The PURELAB[®] QUEST unit should be installed on a flat, level surface, in a clean dry environment 15 - 25 °C. The unit can also be wall mounted using the LA735 wall mounting kit against a vertical wall capable of supporting the combined weight of the unit and mounting kit.



20KG
CAUTION! Must be lifted by two people.

(Fig.1)

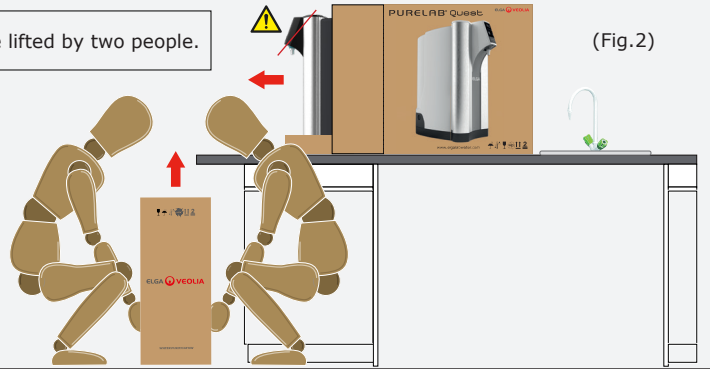

(Fig.2)

a) Use lifting aids to move the product into position. (Fig.1)

b) Place the product on a flat level surface, remove from the packaging. (Fig.2)

Health and Safety Executive, INDG143 (REV 3), Open Government License.

2 RECOMMENDED MAINS FEEDWATER CONNECTION

Temperature 10 - 25°C / Minimum Pressure 2.0 bar - 30 psi (<2 Bar install LA648), Optimum

Running Pressure 4.0 bar - 60 psi, Maximum Pressure 6.0 bar - 90 psi. (Regulate to 4 bars using LA512).

SUPPLY INSTALLED BY A COMPETENT PERSON ONLY. SERVICE ENGINEER OR FACILITIES MANAGER.

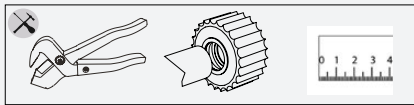

a) ISOLATE the water supply to the sink (Potable water supply).

b) Cut the 15mm copper or plastic inlet water pipe with a suitable 15mm tube cutter.

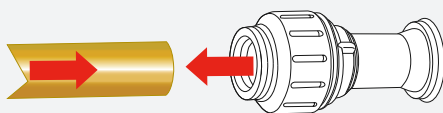

(Fig.3)

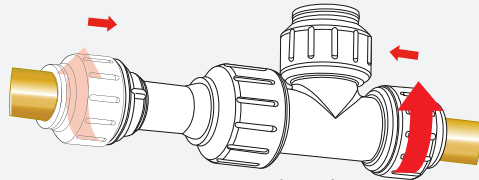

(Fig.4)

c) CONNECT: Attach a 15mm John Guest Slip Tee Connector to both ends of the cut pipe, ensuring that it is fully connected. push until it stops (Fig.3)

d) LOCKING: Twist the screw cap until the cap meets the body of the Slip Tee Connector. Pull to check the connection is secure. (Fig.4)

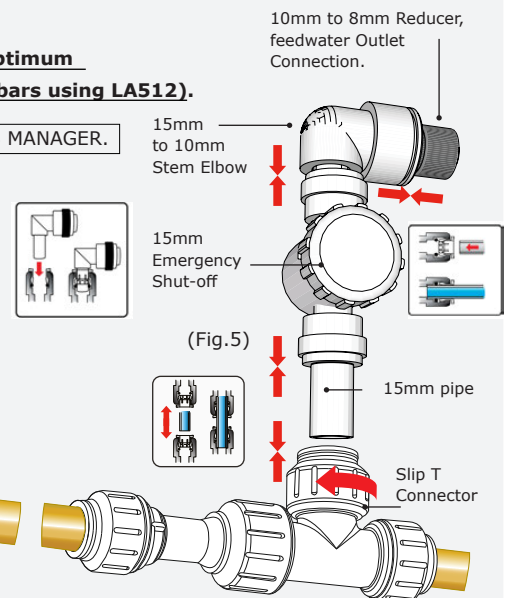

(Fig.5)

e) ASSEMBLE the above parts, this will be for the Feedwater connection for Port 1. (Fig.5)

3 RECOMMENDED DRAIN AND OVERFLOW CONNECTIONS

The drain and overflow tubes will require a drain or a sink capable of handling at least 1.5L / Min with a gravity fall below the level of the unit. Any connections directed to drain or sink should have an air-break device fitted.

a) Use 6 X flow bends from the basic installation kit LA762.

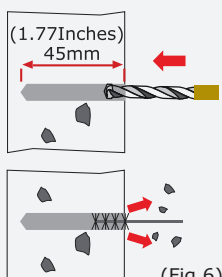
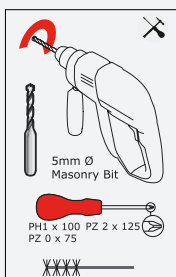

(Fig.6)

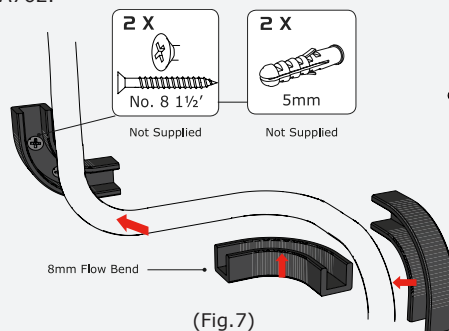

(Fig.7)

b) Fix 8mm flow bends to the wall if required. (Fig.6)

c) Clip in the 8mm pipe. (Fig.7)

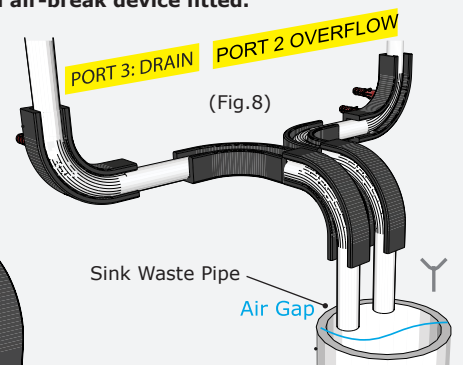

(Fig.8)

d) Example of an air-break device. (Fig.8)

SET - UP / COMMISSIONING

4 CONNECT THE WATER

RO/DI/UV - Potable Water Supply

RO/DI - Potable Water Supply

See Operator's Manual - Feedwater Specifications for more information.



(Fig.9)

a) Remove the transit plug from the water inlet connection. (Fig.9)

Fit a pressure regulator LA512, regulate to 4 bar.



(Fig.10)

b) Using the tube supplied, firmly push one end securely into the water inlet connection. (Fig.10)

5 CONNECT THE OVERFLOW



(Fig.11)

a) Remove the transit plug from the Overflow connection. (Fig.11)



(Fig.12)

b) Using the tube supplied, firmly push one end securely into the Overflow connection. (Fig.12)

6 CONNECT THE DRAIN



(Fig.13)

a) Remove the transit plug from the Drain connection. (Fig.13)

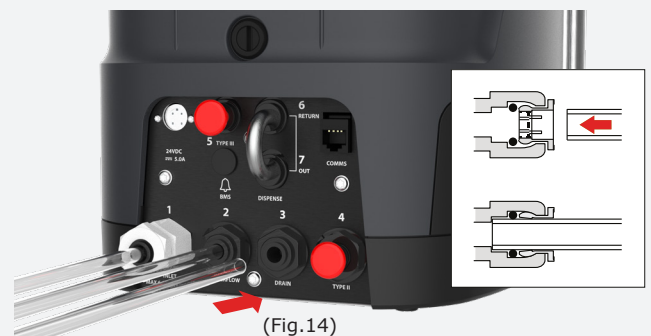

(Fig.14)

b) Using the tube supplied, firmly push one end securely into the Drain connection. (Fig.14)

Connect the other end of the drain and overflow tubes to a sink or suitable drain capable of handling at least 90L/hr.

The drain point should have a gravity fall below the level of the unit and any connections directed to drain should have an air break device fitted.

(See Quick Start Guide - Step 3 for details)

C. Turn on the Feedwater supply, open 15mm emergency shut-off valve and regulator the pressure to 4 bars.

7 ADDITIONAL PURIFIED WATER OUTLET CONNECTIONS

Ports 4,5,6 and 7 do not need to be connected for a standard installation (See Operator's manual - Section 6 for details).

SET - UP / COMMISSIONING

8 CONNECT THE POWER

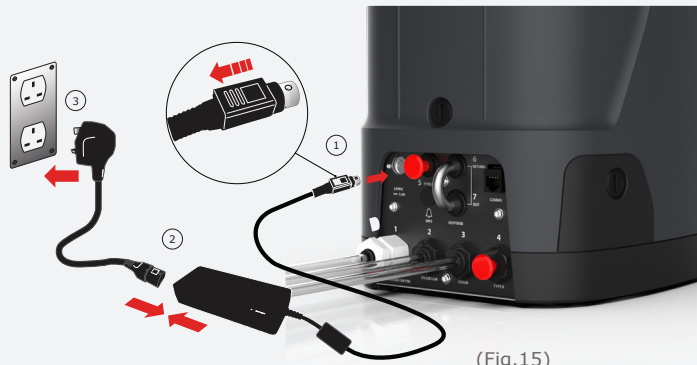

(Fig.15)



(Fig.16)

9 LANGUAGE



(Fig.17)

a) Scroll to find your language.





(Fig.18)

b) Press to accept to confirm.

a) Connect the power cable as shown. (Fig.15)

c) Turn on the power supply, the screen will as shown. (Fig.16)

 b) Only use the power supply provided by ELGA. The power supply and electrical feed must be earthed.

 **WARNING!** CAREFULLY POSITION THE POWER SUPPLY, AVOIDING WATER CONTACT.

10 FOLLOW THE ON SCREEN INSTRUCTIONS



(Fig.19)

a) Write the installation date. (Fig.19)



(Fig.20)

b) Insert LC291 Vent Filter and turn clockwise until hand tight only. (Fig.20)



(Fig.21)

c) Open the right-hand door. (Fig.21)

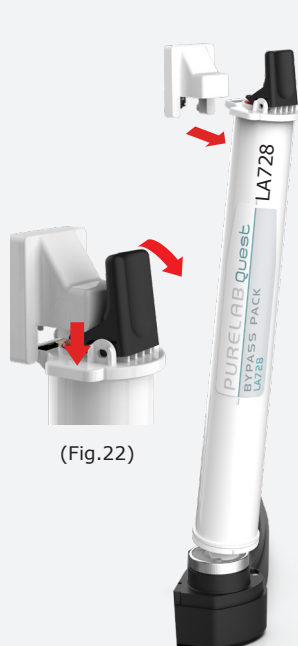

(Fig.22)

d) Remove Bypass Pack LC728. (Fig.22)



(Fig.23)

e) Remove LC292 transit caps. (Fig.23)



(Fig.24)

f) Fit LC292 and follow the on screen instructions. (Fig.24)

g) Please wait 45 minutes for PURELAB QUEST 7L internal reservoir to fill and reach full purity before dispensing any purified water.

If an additional external reservoir is also connected this will start to fill once the internal reservoir is full.

CONTENT

	Quick Start	
1.	Health and Safety Notes	Page 1
1.1	Environnement	Page 1
1.2	Electricity	Page 1
1.3	Ultraviolet Light	Page 1
1.4	Residual Biostat	Page 1
1.5	Personal Protective Equipment (PPE)	Page 1
1.6	Control of Substance Hazardous to Health (COSHH)	Page 1
2.	Introduction	Page 2
2.1	Health and Safety	Page 2
2.2	Product Models	Page 2
2.3	Use of this Manual	Page 2
2.4	Installation	Page 2
2.5	Environment	Page 2
2.6	Commissioning	Page 2
2.7	Customer Support	Page 2
3.	Guide to Your PURELAB® QUEST	Page 3
4.	Product Consumables and Accessories	Page 4
5.	Register Your Product	Page 5
6.	Additional Purified Water Outlet Connections	Page 6 - 8
6.1	Port 4: Type 2 - Water Outlet Connection for an application	Page 6
6.2	Port 5: Type 3 - Water Outlet Connection for an external reservoir	Page 7
6.3	Port 6 and 7 - Water Outlet Connection for a Free-standing Dispenser	Page 8
7.	Quick Reference Guide	Page 9 - 10
7.1	Manual Dispense	Page 9
7.2	Auto Volume Dispense	Page 9
7.3	Deactivating - Auto Volume Dispense	Page 10
7.4	ON - OFF, Menu and Accept	Page 10
8.	Maintenance	Page 11 - 21
8.1	Replacing Ultraviolet Lamp LC210	Page 11 - 13
8.2	Replacing DI Purification Pack LC292	Page 14
8.3	Cleaning the Inlet Filter	Page 15 - 16
8.4	Replacing the Reverse Osmosis Module LC217	Page 17
8.5	Replacing the Vent Filter LC291 and Point-of-Use Filter LC134 / LC145 / LC197	Page 17 - 18
8.6	Sanitization Procedure - LC209 Sanitization Pack	Page 19 - 20
8.7	Sanitization Procedure - LC209-M2 Sanitization Pack	Page 20 - 21
9.	Troubleshooting	Page 22 - 23
10.	Customize Operation	Page 24
10.1	Set Alarm Points	Page 24
10.2	Advanced Data Logging	Page 24
10.3	Software Update	Page 24
11.	Technical Specifications	Page 25 - 26
12.	Warranty / Conditions of sale	Page 27

Copyright Note

The information contained in this document is the property of VWS (UK) Ltd, trading as ELGA Veolia®, and is supplied without liability for errors or omissions.

No part of this document may be reproduced or used except as authorized by contract or other written permission from VWS (UK) Ltd.

The copyright and all restrictions on reproducing and use apply to all media in which this information may be placed.

VWS (UK) Ltd. Pursue a policy of continual product improvement and reserve the right to alter without notice the specification, design, price or conditions of supply of any product or service.

© VWS (UK) Ltd. 2020 - All rights reserved. ELGA® and PURELAB® are registered trademarks of VWS (UK) Ltd.

Copyright Note

Effersan™ is a registered trademark of Activon Inc.

I. HEALTH AND SAFETY NOTICES

HEALTH AND SAFETY NOTES



WARNING!
Please follow the safety information detailed in this instruction sheet. Failure to observe these instructions could result in damage to the equipment, process, associated equipment and injury or death to persons.



Caution!
Failure to observe the instructions could result in damage to the equipment.

1.1 Environment



Caution!
Clean dry indoor. Temp 5-40°C. Humidity max 80%, non-condensing.



Caution!
The PURELAB® QUEST is not designed for use in fume cupboards where chemicals could damage the system.

1.2 Electricity

The appliance coupler (mains lead) or power supply connected to the rear of the unit can be removed to isolate the power supply. If access to this is restricted then it is recommended that access to the mains socket is easily available to disconnect the power supply.



WARNING!
ONLY USE THE APPLIANCE COUPLER (MAINS LEAD) AND POWER SUPPLY PROVIDED, USE OF THESE WILL ENSURE ADEQUATE EARTH PROTECTION. DISCONNECT ELECTRICAL MAINS POWER SUPPLY BEFORE ANY MAINTENANCE WORK IS STARTED. IF THE EQUIPMENT IS USED IN A MANNER NOT SPECIFIED BY ELGA VEOLIA®, THE PROTECTION PROVIDED BY THE EQUIPMENT MAY BE IMPAIRED.



WARNING!
ALWAYS ENSURE THAT THE ELECTRICAL MAINS POWER SUPPLY IS ISOLATED BEFORE WORKING INSIDE.

1.3 Ultraviolet Light



WARNING!
UNDER NO CIRCUMSTANCES SHOULD THE UV LAMP BE CONNECTED AND ACTIVATED WHEN OUTSIDE THE HOUSING. EXPOSURE COULD CAUSE SERIOUS INJURY TO EYES AND SKIN. ENSURE UV LAMP IS DISPOSED OF IN ACCORDANCE WITH LOCAL REGULATIONS.

1.4 Residual Biostat



WARNING!
DURING THE COMMISSIONING CYCLE TRACE RESIDUAL BIOSTAT IS FLUSHED FROM THE SYSTEM. COSHH MATERIAL SAFETY DATA SHEET ARE AVAILABLE UPON REQUEST.

1.5 Personal Protective Equipment (PPE)



WARNING!
MAINTENANCE MUST BE CARRIED OUT WITH PROPER PROTECTIVE EQUIPMENT THAT INCLUDES STERILE LATEX - NITRILE GLOVES CAT 3 AND SAFETY GLASSES WHEN HANDLING GLASS CONSUMABLES.

1.6 Control of Substances Hazardous to Health (COSHH)

Material safety data sheets covering the Purification Packs are available upon request.
Note: Ensure the consumables are disposed of in accordance with local regulations.

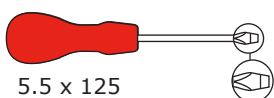

5.5 x 125



Tape Measure

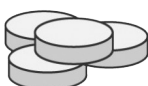

Sanitization Tablets



Tube Keys

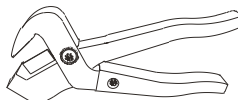

Plastic Pipe Cutters

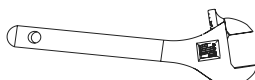

Adjustable Spanner

*Not supplied in basic installation Kit



EN388 & EN374



EN14126



Goggles

2. INTRODUCTION

INTRODUCTION

2.1 Health & Safety

Please ensure you read the Health & Safety notes in the front of this Operator Manual.

2.2 Product Range

This Operator manual has been prepared for PURELAB® Quest product models:

- PURELAB® Quest RO/DI/UV Product No. PQDIUVM1
- PURELAB® Quest RO/DI Product No. PQDIXXM1

PURELAB® Quest converts tap water directly to Type 1, 2 and 3 lab water. The unit is specifically designed for low volume applications and the intermittent demand of the modern laboratory.

2.3 Use of this Manual

This manual guides you through the operation and maintenance of PURELAB® QUEST allowing you to obtain a guaranteed supply of purified water to meet your requirements.

2.4 Installation

The Quick Start Guide shown in the front of this manual shows you how to install and commission the PURELAB® QUEST.

2.5 Environment

The PURELAB® Quest unit should be installed on a flat, level surface, in a clean, dry environment. The unit can also be wall mounted using the purpose designed wall mounting kit against a vertical wall capable of supporting the combined weight of the unit and mounting kit LA735. See INST39088 in-box wall mounting instructions for details.



WARNING!
NOT TO BE USED IN FUME EXTRACTION ENCLOSURES.

2.6 Commissioning

PURELAB® Quest is supplied in a preset commissioning mode which must be completed before purified water can be dispensed, see quick start to complete this procedure.

2.7 Customer Support

If you need help with your product, please call your local ELGA Veolia® representative. For the address of the nearest ELGA Veolia® Sales and Service office visit our website.

www.elgalabwater.com or contact ELGA Veolia at: Email: techsupport@elgalabwater.com

3. GUIDE TO YOUR PURELAB QUEST



4. PRODUCT CONSUMABLES AND ACCESSORIES

Consumables

Part No.	Description	Typical Service Life*	Max. Shelf Life
LC292	Purification Pack (DI)	6 Months	2 Years
LC209	Sanitization Pack	12 Months	2 Years
LC209-M2	Tablet Sanitization Pack (one cycle of 90 minutes)	12 Months	2 Years
LA728	Bypass Pack (Removed during commissioning)	N/A	N/A
LC210	UltraViolet Lamp (UV)	12 Months	2 Years
LC291	Vent Filter (VF)	1 Year	2 Years
LC217	Reverse Osmosis Module (RO Service Module)	Typical Life 2 Years	2 Years
LC134	Point-Of-Use 0.2µm Mirco Filter (POU)	3 Months	2 Years
LC145	Point-Of-Use 0.2µm Mirco Filter (POU)	3 Months	2 Years
LC197	Point-Of-Use Bio Filter (POU)	3 Months	2 Years
SKU:40020	Effersan® Sanitization Tablet	1 every 6 months	8 Months

Accessories

LA821	External Pre-treatment Filter Kit	6 Months	2 Years
LA735	Wall Mounting Kit	N/A	N/A
LA512	Feedwater Pressure Regulator	N/A	N/A
LA757	External 15L Reservoir	N/A	N/A
LA758	External 30L Reservoir	N/A	N/A
LA648	External Boost Pump (Feedwater less than <2 Bar)	N/A	N/A

* Consumable Life is an estimate only, and will depend on the application and feedwater quality.



5. REGISTER YOUR PRODUCT

5. Registering a Product

Taking the time now to register will mean that we can provide a better service to you in the future. We can contact you about product information and service updates.

Why Register your product?

- Validated your product warranty
- Proof of product registration
- Receive software and service updates

How can I quickly register?

The model number and serial number can be found on the ratings plate, see below:

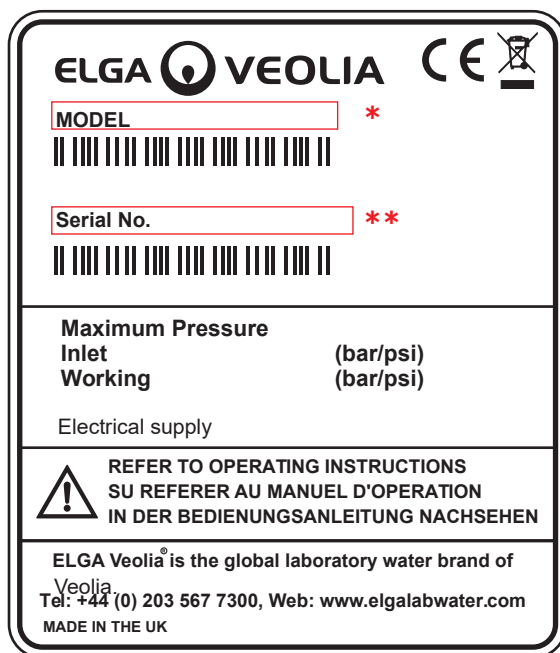

* Model number

** Serial number

Enter the model and serial number into the online form at:
<https://www.elgalabwater.com/support/register-a-product>

6. ADDITIONAL PURIFIED WATER OUTLET CONNECTIONS

The purified water outlet connections are located at the rear of PURELAB® QUEST, these are used for purified connections to other applications or products.



Caution!

Port 4: Type 2 Outlet should not be connected to a pressurized application, this may cause back-flow into PURELAB® Quest.

6.1 PURELAB Quest Port 4: Type 2 - Water Outlet Connection for an application

STEP 1 - Removing the transit plug and connecting the tube

1. Remove the transit plug from water outlet connection Port 4: Type 2 Outlet (Fig.1).
2. Insert an 8mm plastic tube into Port 4: Type 2 Outlet (Fig.2).

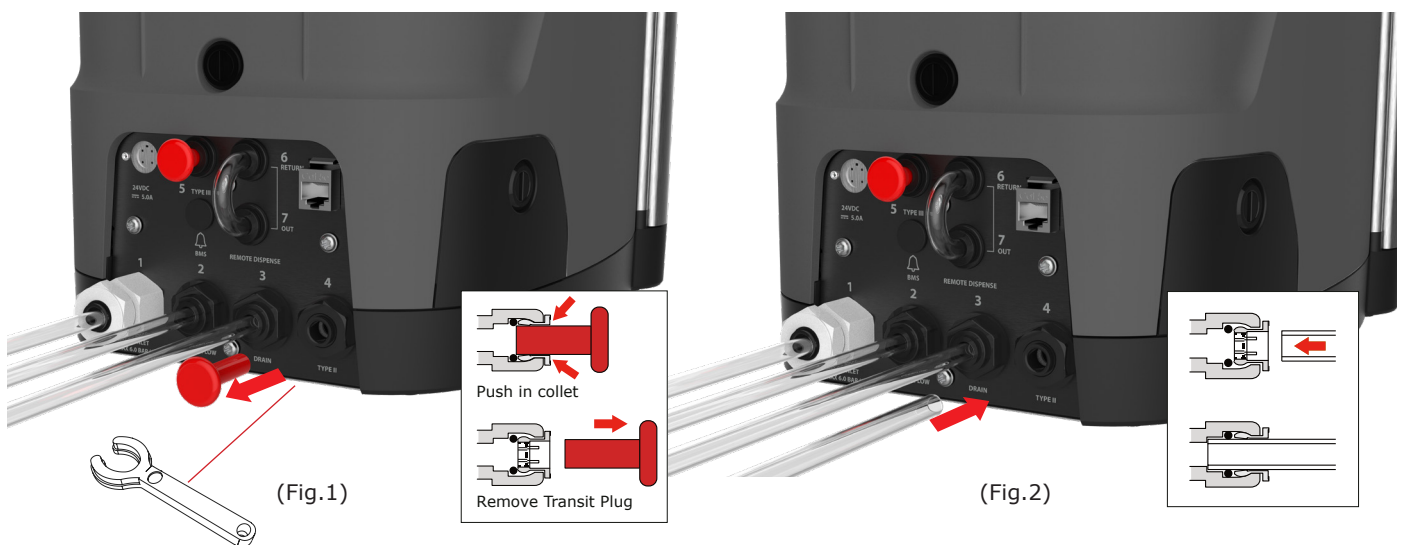

STEP 2 - Opening the Purified Water Outlet Valve

1. Undo the quarter turn fastener to the access panel (Fig.3).
2. Connect the 8mm tube to an applicaton or product that requires purified water.
3. Open the manual isolation valve (Turn 90° Anti-clockwise) (Fig.4).

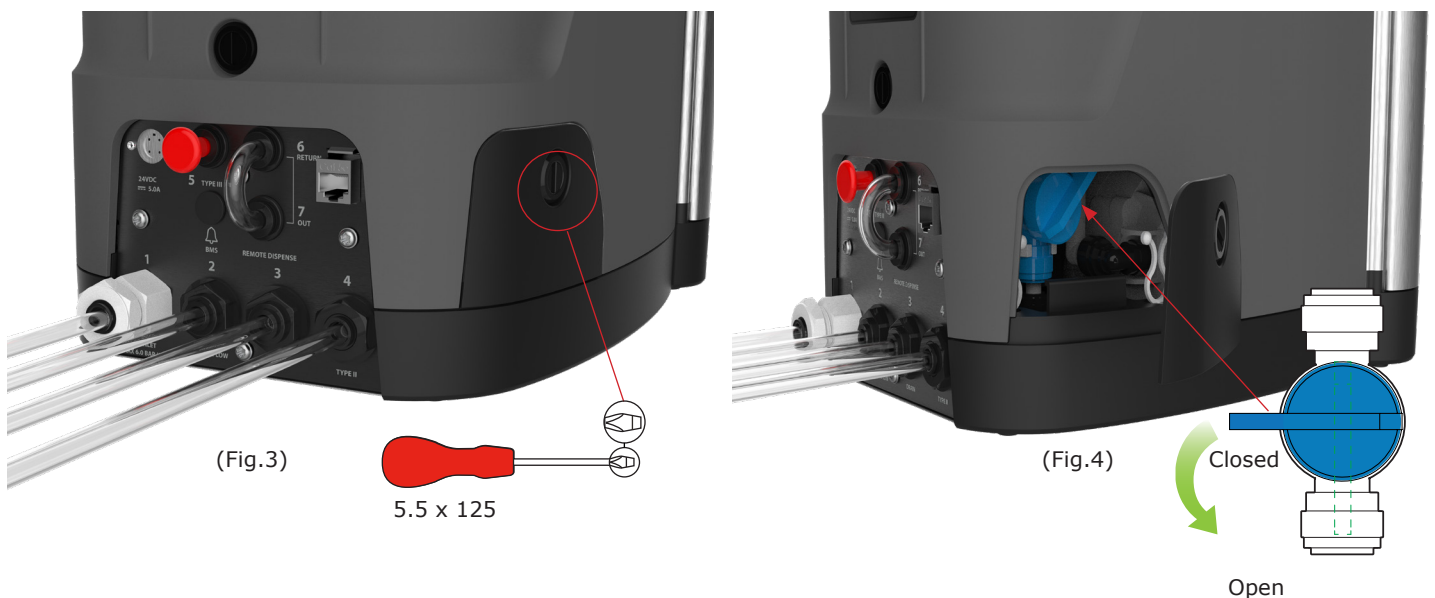

6. ADDITIONAL PURIFIED WATER OUTLET CONNECTIONS

6.2 PURELAB Quest Port 5: Type 3 - Water Outlet Connection for an external reservoir

STEP 1 - Removing the transit plug and connecting the tube

1. Remove the transit plug from water outlet connection Port 5: Type 3 Outlet (Fig.1).
2. Insert an 8mm plastic tube into Port 5: Type 3 Outlet (Fig.2).

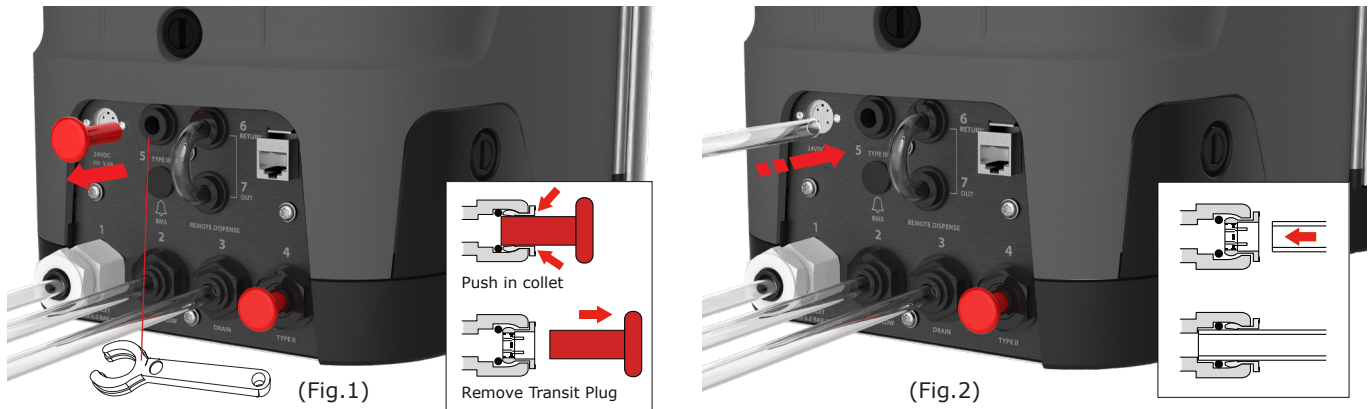

STEP 2 - Connecting water and power to the reservoir

1. Remove the transit plug from reservoir Port 1: Inlet (Fig.3).
2. Insert the 8mm plastic tube from PURELAB Quest Port 5: Outlet into reservoir Port 1: Inlet (Fig.3).
3. Insert an 8mm plastic tube into the overflow and connect to drain (Fig.4).

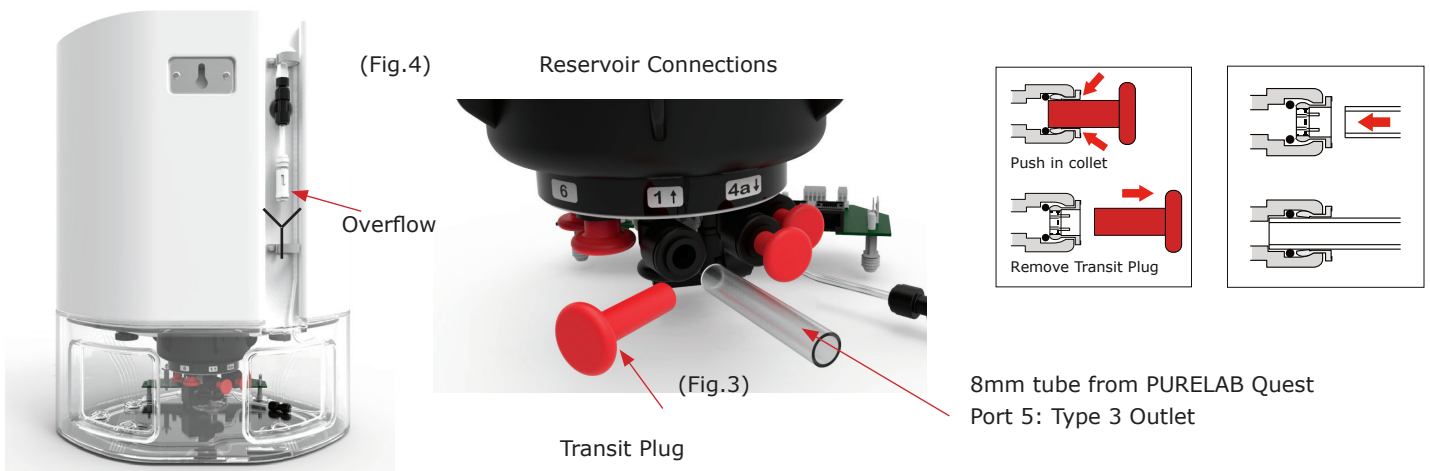

4. Connect the supplied comms lead from PURELAB Quest into J2 reservoir comms connection (Fig.5).

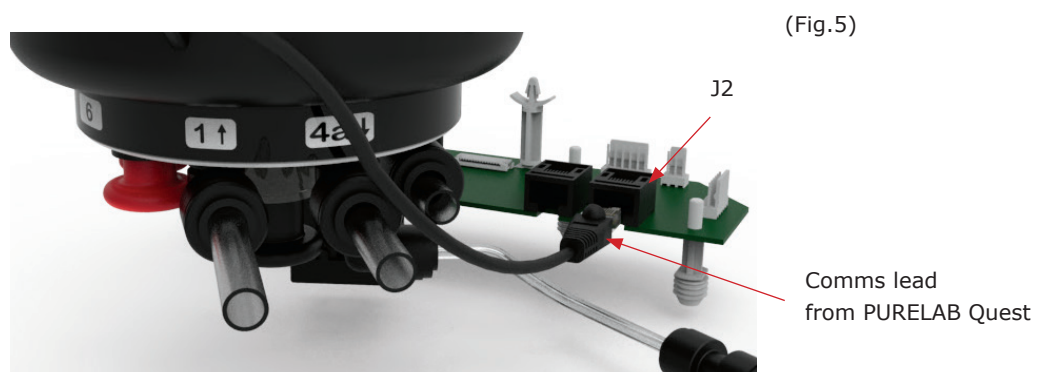

6. ADDITIONAL PURIFIED WATER OUTLET CONNECTIONS

6.3 Port 6 and 7 - Water connections for Free-Standing Dispenser

STEP 1 - Disconnect the power

1. Disconnect the power supply before removing the metal loop (Fig.1).

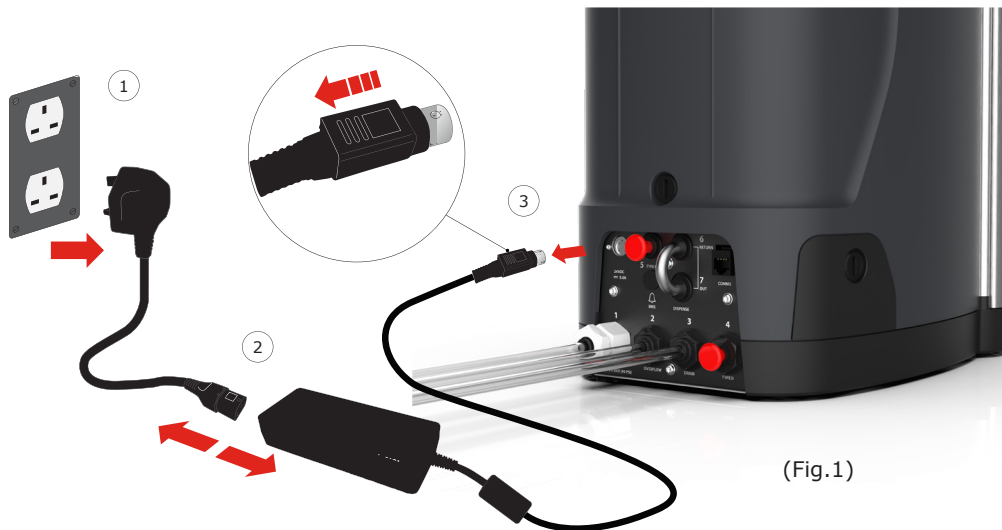

WARNING!
MAKE SURE THAT THE POWER SUPPLY CANNOT COME INTO CONTACT WITH WATER.

STEP 2 - Removing the metal loop

1. Wait a couple of minutes before removing the metal loop.

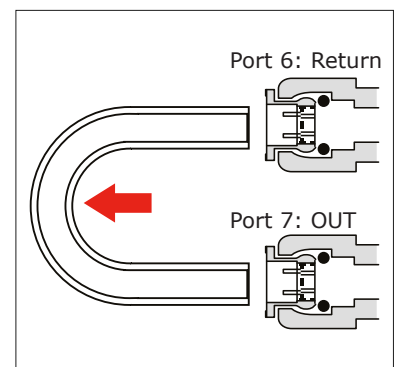
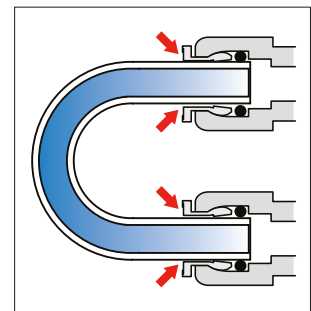
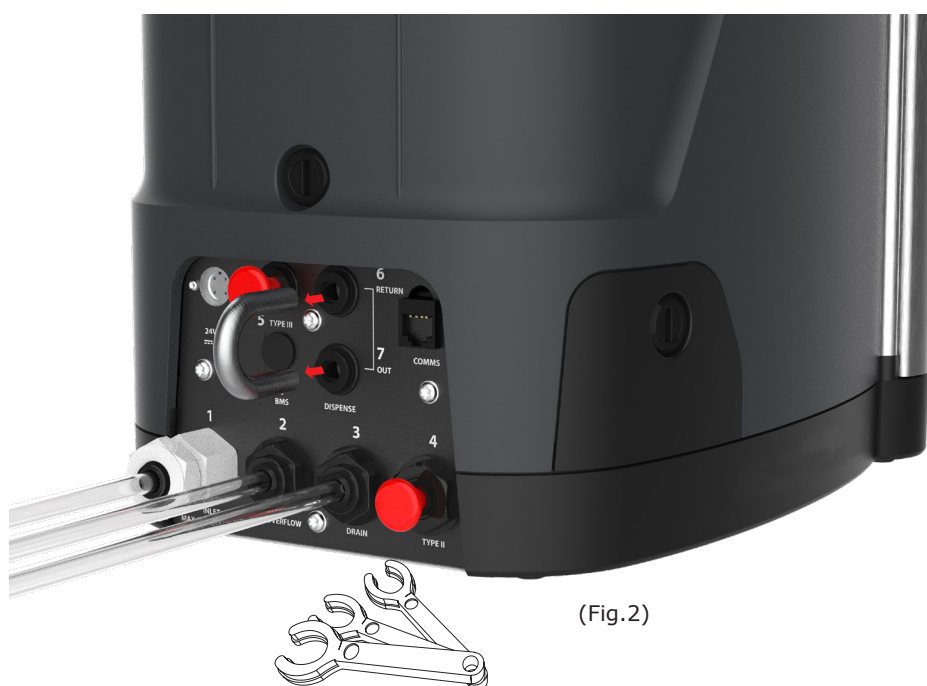

2. Remove the metal loop from Port: 6 and Port: 7 using an 8mm tubing key (Fig.2).
3. Follow the Free-standing Dispenser - Quick Start Guide to complete this installation.

7. QUICK REFERENCE GUIDE

7.1 Manual Dispense



Press dispense at anytime, release to stop.

7.2 Auto Volume Dispense



Press Auto-Volume at anytime.



Press to scroll up and down, press dispense to confirm.

7. QUICK REFERENCE GUIDE

7.3 Deactivating - Auto Volume Dispense

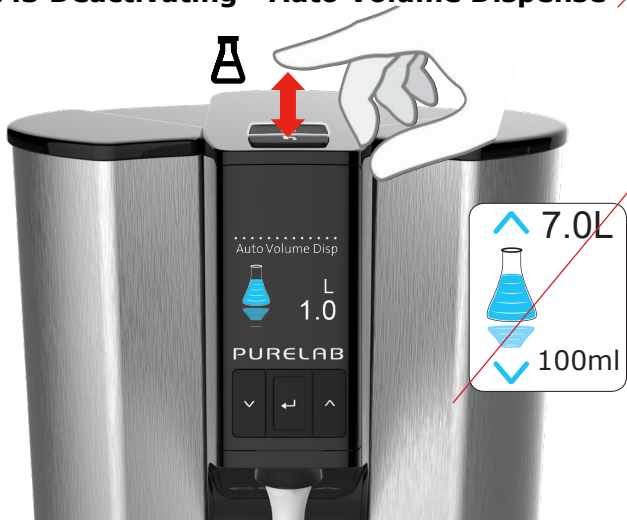

Press Auto-Volume dispense at anytime to exit.

7.4 ON - OFF, Menu and Accept

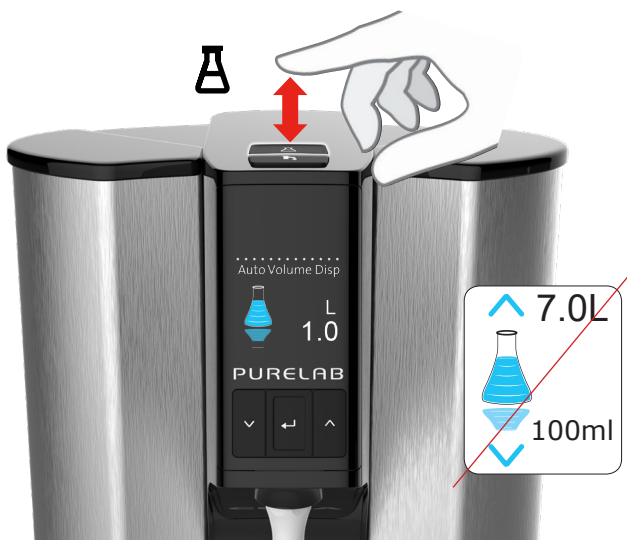

Deactivate Auto-Volume dispense, press once.



Press and Hold for 2 seconds to enter the Main Menu.
Scroll to select a feature in the Main Menu.

8. MAINTENANCE

Maintenance

Any maintenance work not included in this operator manual should be carried out by an approved Service engineer or technician, please contact: <https://www.elgalabwater.com/support/product-support>

 Note:
Disposing of used consumable items should be in accordance with local statutory regulations.

8.1 Replacing Ultraviolet Lamp LC210 - PQDIUVM1

The Ultraviolet (UV) Lamp should be replaced when;

- UV Lamp failure occurs.
- UV Lamp efficiency decreases affecting water quality.

If either situation occurs, a message will be displayed on screen asking you to replace the UV Lamp.

 **WARNING!**
UV-C RADIATION IS HARMFUL TO EYES AND SKIN.
LC210 UV LAMP SHOULD ONLY BE OPERATED INSIDE LC210 CHAMBER.

IT'S STRONGLY RECOMMENDED THAT DURING THE HANDLING OF LC210 UV LAMP CUT-RESISTANT GLOVES SHOULD BE WORN FOR PROTECTION.



EN388 & EN374



Goggles

 **WARNING!**
LC210 UV LAMP CONTAINS MERCURY HAZARDOUS TO HEALTH. FRAGILE GLASS DO NOT BREAK

IF BROKEN MAY CAUSE REDNESS OR IRRITATION AS A RESULT UPON CONTACT WITH SKIN OR EYES, PLEASE SEEK MEDICAL ATTENTION.



EN388 & EN374



Goggles

STEP 1 - Switching OFF the power supply

1. ISOLATING the power supply, follow the instructions below (Fig.1).

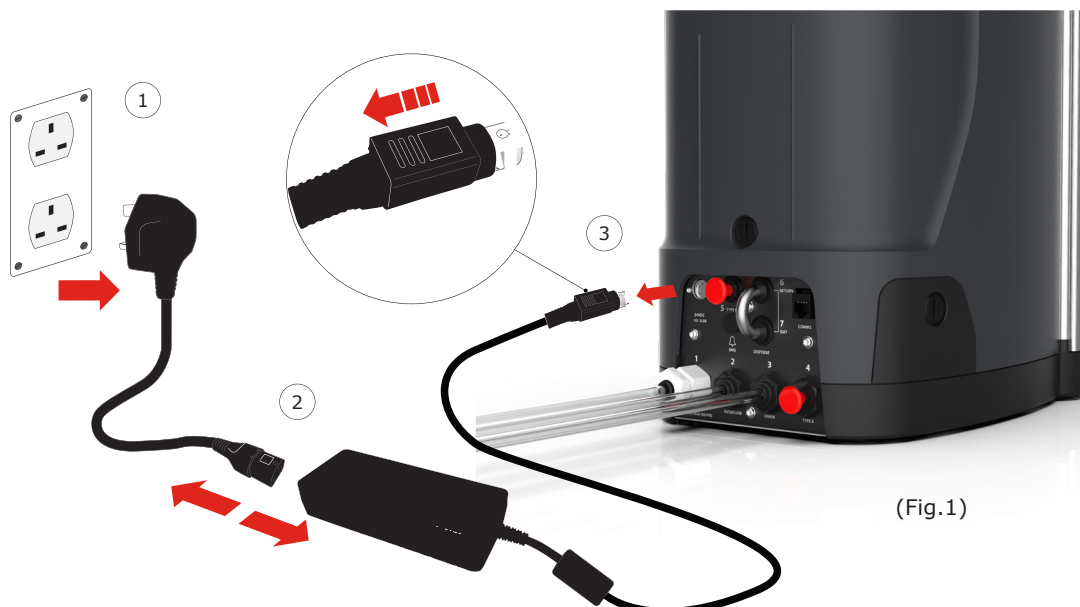

(Fig.1)

8. MAINTENANCE

STEP 2 - Removing LC210 UV Lamp

1. Open the left side door (Fig.2).
2. Disconnect the UV lamp wiring connector (Fig.3).



(Fig.2)



(Fig.3)

STEP 3 - Removing LC210 UV Lamp continued

-  **Caution!**
Use cut resistant gloves when handling the new UV Lamp LC210.



1. Carefully remove the UV lamp from it's chamber (Fig.4).
2. Discard used UV lamp in accordance with local regulations (Fig.5).



(Fig.4)



(Fig.5)

STEP 4 - Replace LC210 UV Lamp

1. Unpack the new LC210 lamp from it's product packaging (Fig.6).



(Fig.6)



8. MAINTENANCE

- Wipe the glass with the alcohol wipe
- Slide the new LC210 UV lamp into the UV chamber (Fig.7).
- Connect the UV lamp connector, making sure it is aligned correctly with the pins (Fig.8).
(Use the black arrows as a guide)



(Fig.7)

(Fig.8)



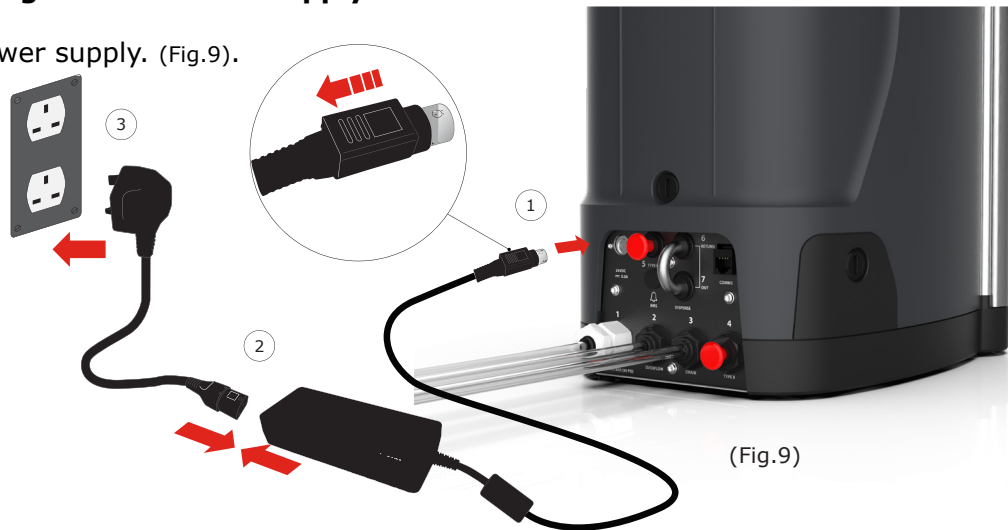

STEP 5 - Switching ON the Power Supply

- Connect the power supply. (Fig.9).



(Fig.9)

STEP 6 - Resetting the LC210 UV Lamp reminder

- Hold and press accept  to enter the main menu. (Fig.10).
- Scroll  +  and select 'Reset Reminders', press accept  to confirm (Fig.11).
- Scroll and select the UV filter, press accept  to confirm (Fig.12).
- The reset reminder is now set, normal operation will resume (Fig.13).



(Fig.10)



(Fig.11)

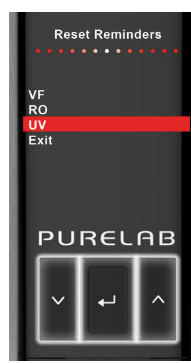

(Fig.12)







(Fig.13)

8. MAINTENANCE

8.2 Replacing LC292 DI Purification Pack

Step 1 - Removing the used LC292 Purification Pack

1. Press and hold accept  for 2 seconds to enter the Main Menu (Fig.1).
2. Scroll  +  and press accept  'Changing Purification Pack'
3. Open the right hand door (Fig.2).
4. When instructed release the LC292 Purification Pack by 'Pull back' and 'Push down' on the handle (Fig.3).
5. Dispose of in accordance with local regulations (Fig.4).



(Fig.1)

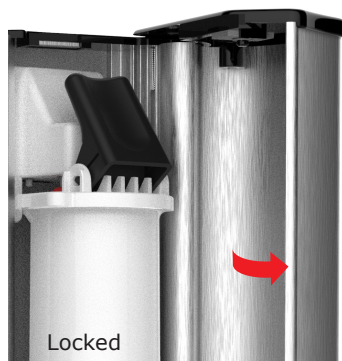

(Fig.2)

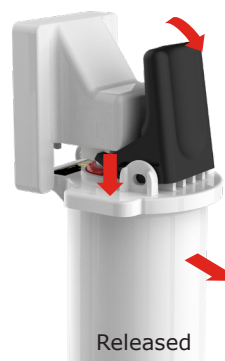

(Fig.3)



(Fig.4)

Step 2 - Unpacking the New LC292 Purification Pack

1. Unpack the new Purification Pack and remove the transit plugs (Fig.5).

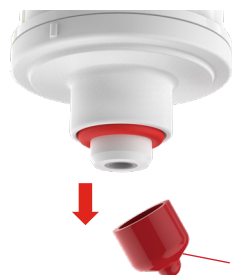

Transit Plug

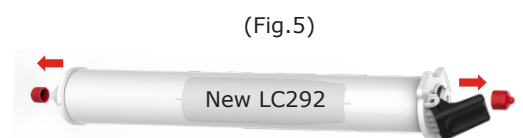

(Fig.5)

Step 3 - Installing the New LC292 Purification Pack

1. When instructed, insert the base of the new Purification Pack first, then push down and inwards (Fig.6).
2. Follow the on screen instructions to complete the procedure.

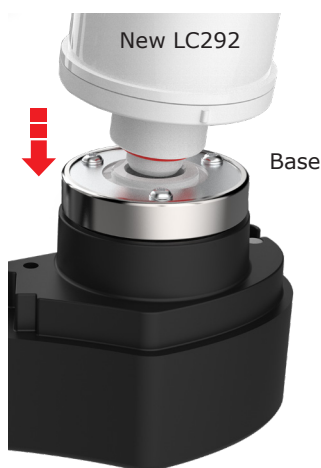

(Fig.6)

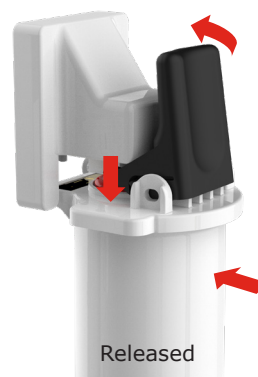

Released

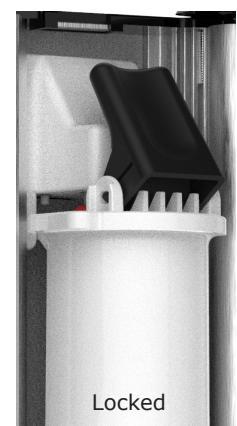

Locked

8. MAINTENANCE

8.3 Cleaning the Inlet Feedwater Filter

PURELAB® QUEST is fitted with an inlet filter to protect it from water particles, which could affect the performance of the product. It is recommended that the inlet filter assembly is periodically cleaned to remove any particles or debris that can cause a blockaged.

STEP 1 - Isolate the power supply

1. Isolate the power supply to the product (Fig.1).

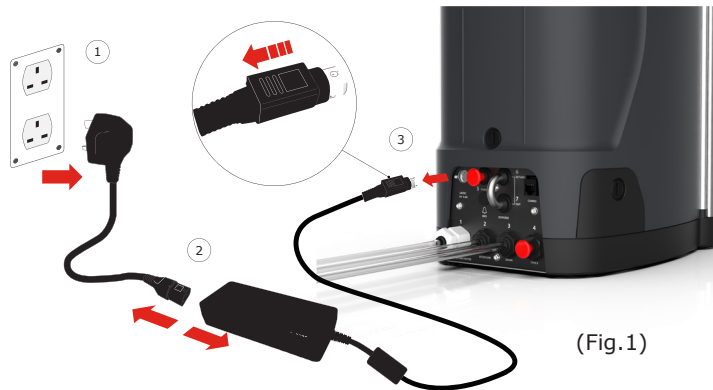

STEP 2 - Turn OFF Feedwater Supply

STEP 3 - Dismantle the Inlet Filter Assembly

1. Remove the feedwater plastic tube, using an 8mm tubing key (Fig.2).
2. Unscrew the inlet filter nut with an adjustable spanner (Fig.3).

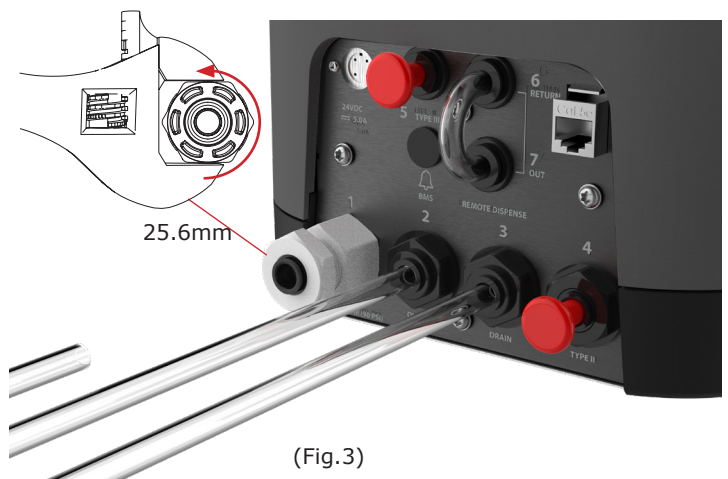
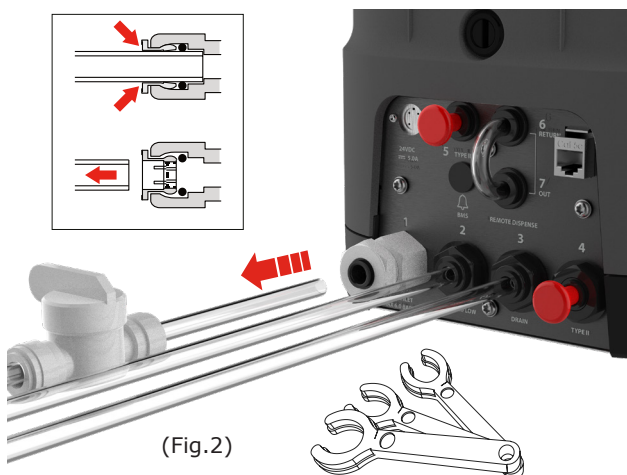

8. MAINTENANCE

STEP 4 - Cleaning the Inlet Feedwater Filter

1. Check the mesh filter for damage and clean with purified water (Fig.4).
2. Insert the black rubber washer and mesh filter into its original position (Ensure that the mesh filter dome is facing outwards)
3. Re-Assemble the inlet feedwater filter assembly (Fig.5).

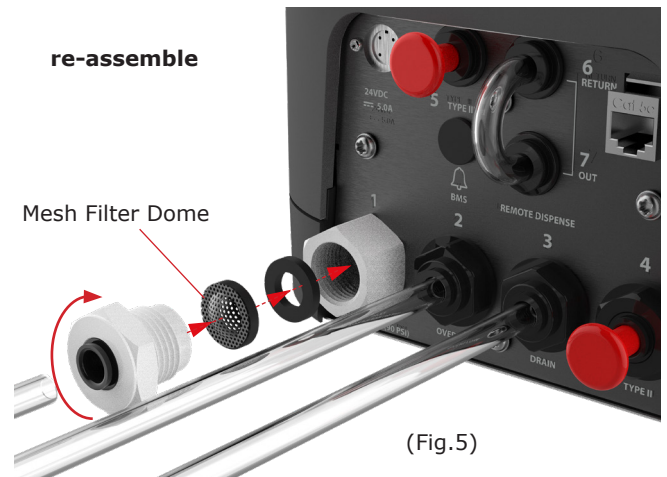
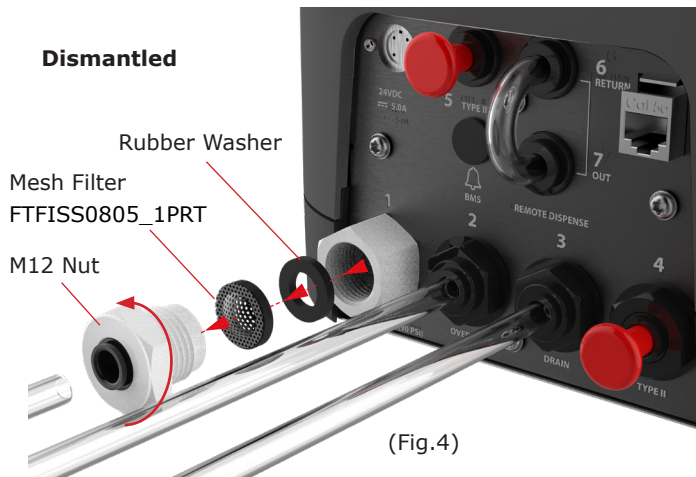

STEP 5 - Reconnecting the Feedwater Supply and Power Supply

1. Reconnect the tube and open the valve, restoring the water connection.
2. Reconnect the power supply to the product (Fig.6).
3. Switch ON to resume normal operation.

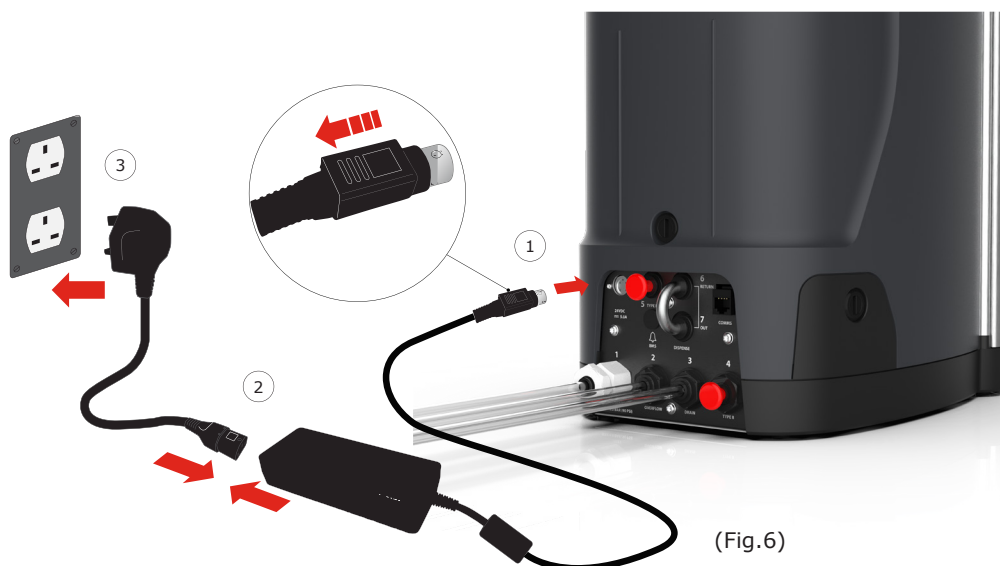

8. MAINTENANCE

8.4 Replacing LC217 Reverse Osmosis Module

PURELAB® QUEST is fitted with a Reverse Osmosis (RO) module which is replaced during a product service or if permeate water purity or flow rate is not adequate and does not meet predicted performance levels. Please contact product support for more information: <https://www.elgalabwater.com/support/product-support>

8.5 Replacing Vent Filter LC291 and Point-of-Use Filter LC134 / LC145 / LC197

Step 1 - Removing the used LC291 Vent Filter

1. Unscrew the used LC291 vent filter from the reservoir (Fig.1).
2. Dispose of the used LC291 vent filter in accordance with local regulations (Fig.2).



(Fig.1)

(Fig.2)

Step 2 - Unpacking the Vent Filter and Install



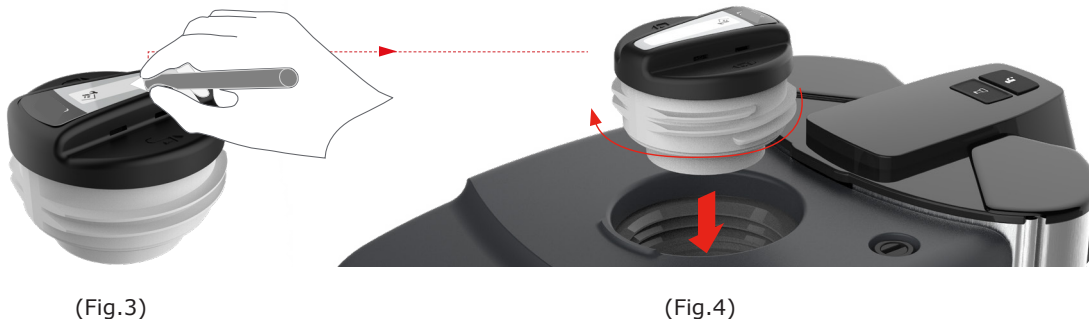

1. Unpack the new LC291 Vent filter from its outer packaging, write the installation date (Fig.3).
2. Screw the new LC291 Vent filter into the reservoir (Fig.4).



(Fig.3)

(Fig.4)

Step 3 - Reset the Vent Filter Reminder

1. Hold and press accept  to enter the main menu. (Fig.5).
2. Scroll  +  and select 'Reset Reminders', press accept  to confirm (Fig.6).
3. Scroll and select the VF, press accept  to confirm (Fig.7).
4. The reset reminder is now complete, normal operation will resume (Fig.8).



(Fig.5)

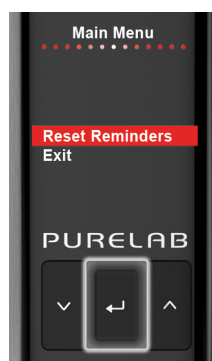

(Fig.6)

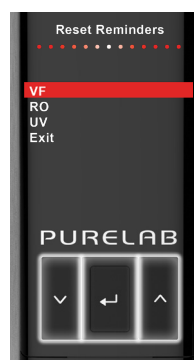

(Fig.7)



(Fig.8)

8. MAINTENANCE

Replacing the Point-Of-Use Filter LC134 / LC145 / LC197

Step 1 - Removing the Dispense Tip

1. Unscrew the dispense tip from underneath the display (Fig.1).
2. Do not dispose of the dispense tip, this part is required for the sanitization procedure (Fig.2).



(Fig.1)



(Fig.2)

Step 2 - Unpacking the LC134 / LC145 / LC197 Point-Of-Use Filter and Installing

1. Unpack the new POU filter from its outer and inner packaging, remove the cap (Fig.3).
2. Coupler is not required for PURELAB® QUEST, screw in the Point-of-Use filter (Fig.4).

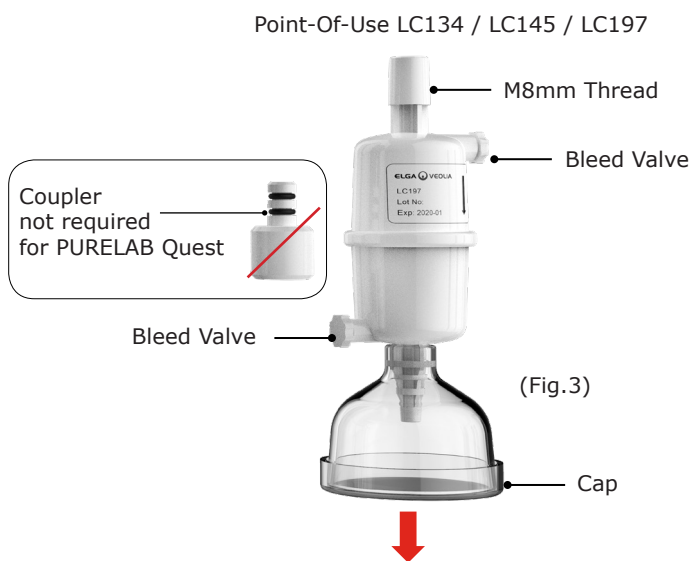

(Fig.3)



(Fig.4)

3. Slightly open both bleed valves, before dispensing any water to release any trapped air (Fig.5).
4. Press the dispense button, drawing water through and close both bleed valves (Fig.6).
5. Installation is completed, normal operation can resume.



(Fig.5)



(Fig.6)





8. MAINTENANCE

The unit is sanitized to maintain or recover microbiological purity of the product water, sanitization is recommended every 12 months.

- It should be carried out if the product has been switched OFF for a prolonged period.
- If the unit has been operated under adverse conditions such as in high temperatures.
- If the bacteria counts are outside the recommend levels - See section 11 Technical Specifications.

 **WARNING!**
IT'S STRONGLY RECOMMENDED THAT DURING THE SANITIZATION PROCEDURE PPE IS WORN. ALWAYS FOLLOW RECOMMENDATIONS FOUND IN THE MANUFACTURES MATERIAL SAFETY DATA SHEET AND ANY APPLICABLE OSHA STANDARDS FOR CHEMICAL HANDLING.

 
EN388 & EN374 Goggles

 **WARNING!**
BEFORE STARTING THIS PROCEDURE LABEL PURELAB® QUEST WITH THE ATTACHED WARNING SIGN.





8.6 Sanitization Procedure - LC209 Sanitization Pack

Step 1 - Unpacking the LC209 Sanitization Pack

1. Remove the Sanitization Pack LC209 from the outer packaging.
2. Remove the transit plugs from either end of the pack and dispose (Fig.1).



Step 2 - Remove the used Purification Pack LC292 and Install the LC209 Pack

1. Press and hold accept  for 2 seconds to enter the Main Menu (Fig.2).
2. Scroll  +  and select 'Sanitization'  in the Main Menu (Fig.2).
3. Open the right hand door to the Purification Pack housing (Fig.3).
4. Release the pack 'Pull back' and 'Push down' on the handle (Fig.4).
5. Dispose of the used Purification Pack in accordance with local regulations (Fig.5).



8. MAINTENANCE

Step 3 - Installing LC209 Sanitization Pack

1. Insert the base of the Sanitization Pack LC209 first, then clip into position (Fig.6).
2. Follow the on screen instructions to complete this procedure.



8.7 Sanitization Procedure - LC209-M2 Sanitization Pack (USA ONLY)

Step 1 - Unpacking the LC209-M2 Sanitization Pack

1. Remove the Sanitization Pack LC209-M2 from the outer packaging.
2. Remove the transit plugs from either end of the pack and dispose (Fig.1).



Step 2 - Removing the base from LC209-M2

1. Unscrew the pack base, using the red molded hand tool (Fig.2).

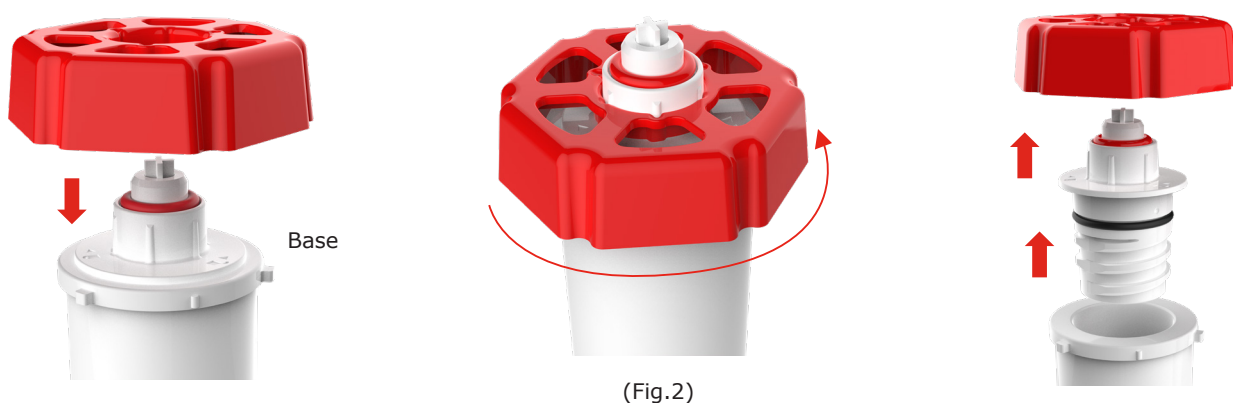



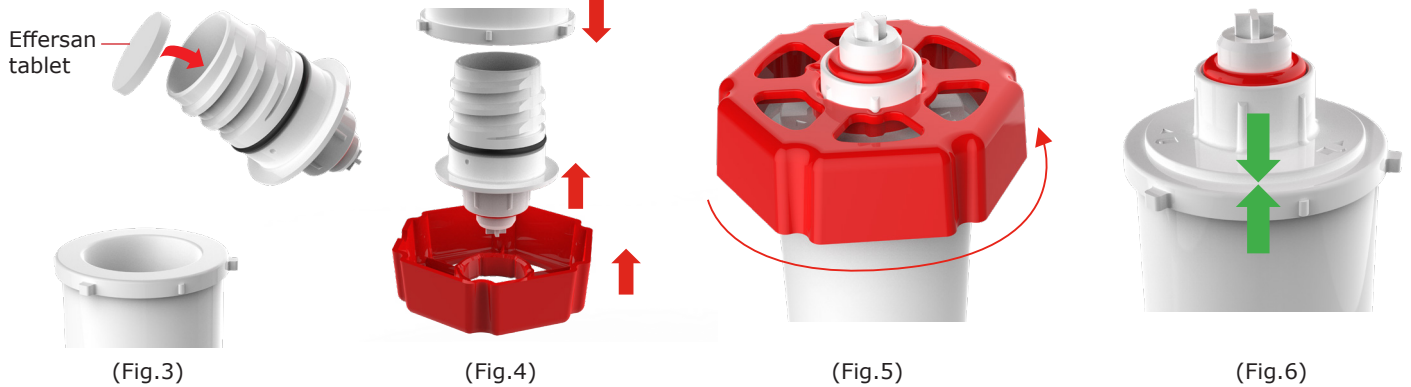

8. MAINTENANCE

Step 3 - Insert a Sanitization Tablet into LC209-M2

1. Insert 1 X Effersan Sanitization tablet into the chamber (Fig.3).
2. Re-assemble the LC209-M2 pack (Fig.4).
3. Hand tighten using the provided moulded tool (Fig.5).
4. Ensure there are no gaps in the pack base (Fig.6).



Step 4 - Remove the used Purification Pack LC292 and Install the LC209-M2 Pack

1. Press and hold accept  for 2 seconds to enter the Main Menu (Fig.7).
2. Scroll  +  and select 'Sanitization'  in the Main Menu (Fig.7).
3. Open the right hand door to the Purification Pack housing (Fig.8).
4. Release the pack 'Pull back' and 'Push down' on the handle (Fig.9).
5. Dispose of the used Purification Pack in accordance with local regulations (Fig.10).



Step 5 - Installing LC209-M2 Sanitization Pack

1. Insert the base of the Sanitization Pack LC209-M2 first, then clip into position (Fig.11).
2. Follow the on screen instructions to complete this procedure.



9. TROUBLESHOOTING

This section covers some of the issues that could occur with your PURELAB® QUEST, and provides the troubleshooting steps to help you resolve the problem.

For product support, please contact: <https://www.elgalabwater.com/support/product-support>



WARNING!

ALWAYS ENSURE THAT THE POWER SUPPLY IS ISOLATED, DURING ANY MAINTENANCE WORK.











Issues	Action
<p>Blank Display Screen</p>	<p>1. Press any button to wake from sleep mode.</p> <p>or</p> <p>2. Check the power supply is connected to the product, ensuring that all connections are securely fitted. (Turn the power OFF/ON)</p> <p>or</p> <p>3. Check the plug socket fuse, replace if necessary.</p>
<p>Unable to Enter the Features in the Main Menu</p>	<p>1. Check the product is turned ON.</p> <p>or</p> <p>2. Make sure Auto-Volume is disabled. (See section 7.3 - Quick Reference Guide)</p>
<p>Message Displayed - Purification Pack Change Reminder</p>	<p>1. Replace the Purification Pack. (See section 8.2 Replacing Purification Pack LC292)</p>
<p>Incorrect Volume of Water</p>	<p>1. Select Auto-Volume Calibration in the main menu.</p>
<p>Purification Pack Life</p>	<p>1. Do not exceed 10L of dispensed water a day. <small>* Available Volume of Type 1 and 2 water, combined; Increased use will reduce purification pack life.</small></p> <p>or</p> <p>2. Test the feedwater supply, using a water testing kit.</p> <p>Contact product support for advice: https://www.elgalabwater.com/support/product-support (See section 11 Technical Specifications - Feedwater - Conductivity)</p> <p>or</p> <p>If permeate water purity or flow rate is not adequate and does not meet predicted performance levels. Please contact product support for more information: https://www.elgalabwater.com/support/product-support</p>

9. TROUBLESHOOTING

Issues	Action
<p>Message Displayed - Sanitization Reminder</p>	<p>1. Complete a Sanitization Procedure. (See section 8.6 / 8.7 Sanitization Procedures)</p>
<p>Message Displayed - UV Lamp Change Reminder</p>	<p>1. Complete a UV Lamp change. (See section 8.1 Replacing Ultraviolet Lamp)</p> <p>2. Reset UV Lamp reminder. (See section 8.1 Replacing Ultraviolet Lamp)</p>
<p>Message Displayed - High Temperature Water Alarm</p>	<p>1. Adjust the alarm points settings via Main Menu. or</p> <p>2. Check the feedwater temperature.</p> <p>3. Press the Dispense button to draw some water through the system, switch OFF and restart.</p>
<p>Reduced Dispensing Flow Rate</p>	<p>1. Check the mesh feedwater inlet filter for blockages. (See section 8.3 Cleaning the Inlet Filter)</p> <p>or</p> <p>2. Replace the Point-Of-Use Filter. (See section 8.5 Replacing the Vent Filter LC291 and Point-Of-Use Filter LC134 - LC145 - LC197)</p> <p>or</p> <p>3. Check the feedwater valves are fully opened. (See section 8.3 Cleaning the Inlet Filter)</p>
<p>Message Displayed - Dispense Water Purity Alarm</p>	<p>1. Check the alarm points settings via Main Menu. (See section 10.1 Set Alarm Points)</p> <p>or</p> <p>2. Replace the Purification Pack LC292 and wait for the cycle to complete. (See section 8.2 Replacing the Purification Pack LC292)</p> <p>or</p> <p>3. Replace the Ultraviolet Lamp LC210. (See section 8.1 Ultraviolet Lamp LC210)</p> <p>(Water Purity Alarm is active during commissioning, see quick start)</p>

10. CUSTOMIZE OPERATION

10.1 Set Alarm Points

1. Hold and press accept  to enter the main menu (Fig.1).
2. Scroll  +  and select Set Alarm Points, press accept  to confirm (Fig.2).
3. Scroll  +  and select a feature, press accept  to confirm (Fig.3).
4. Adjust the valve by scrolling  + , press accept  to save (Fig.4).
5. Normal operation will now resume. (Fig.5).



(Fig.1)



(Fig.2)

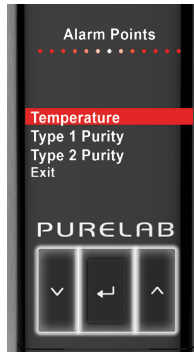

(Fig.3)









(Fig.4)



(Fig.5)

10.2 Advanced Data Logging

1. Insert a USB stick into the USB port (Fig.1).
2. Scroll  +  and select 'Start Data Logging', press accept  to confirm (Fig.2).
3. Scroll  +  and select an interval data recording time, press accept  to confirm (Fig.3).
4. To finish recording press the down  and remove the USB. (Fig.4).
5. Downloaded Data files can be viewed on your PC or Mac.



USB Port

(Fig.1)

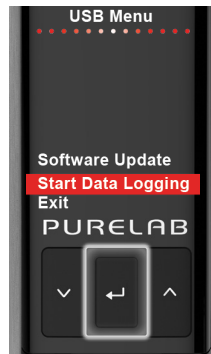

(Fig.2)

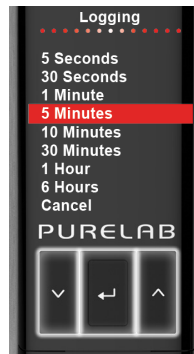





(Fig.3)



(Fig.4)



10.3 Software Update

1. Download the latest software file onto a blank USB at: www.elgalabwater.com/customize
2. Scroll  +  and select 'Software Update', press accept  to confirm (Fig.2).
3. Progress will be displayed on screen (Fig.3).
4. Once completed PURELAB QUEST will power OFF, hold and press  accept to power ON (Fig.4).
5. Software update is now complete, normal operation will resume (Fig.5).



USB Port

(Fig.1)



(Fig.2)



(Fig.3)



(Fig.4)



Software Version

(Fig.5)

II. TECHNICAL SPECIFICATIONS

Technical Specifications

Feedwater Specifications		
Model	PURELAB® QUEST RO/DI/UV - PQDIUVM1	PURELAB® QUEST RO/DI - PQDIXXM1
Water Source	(Potable Water Source)	(Potable Water Source)
Conductivity	<2000µS/cm (high conductivity feedwaters may lower purification pack life and raise Type 3 water conductivity)	<2000µS/cm (high conductivity feedwaters may lower purification pack life and raise Type 3 water conductivity)
Hardness	<350 ppm as CaCO ₃	<350 ppm as CaCO ₃
Free Chlorine	<0.05 ppm Cl ₂	<0.05 ppm Cl ₂
Chloramine	<0.02 ppm Cl ₂	<0.02 ppm Cl ₂
Total Chlorine	<0.05 ppm Cl ₂	<0.05 ppm Cl ₂
Silica	<30 ppm SiO ₂	<30 ppm SiO ₂
Carbon Dioxide (CO ₂)	<30 ppm (recommended <20 ppm)	<30 ppm (recommended <20 ppm)
Fouling Index	<10	<10
Iron / Manganese	<0.5 ppm Fe/Mn	<0.5 ppm Fe/Mn
TOC (Total Organic Carbon)	Recommended <2 ppm	Recommended <2 ppm
Environment		
Temperature	4 - 40 °C (recommended 10 - 25 °C)	4 - 40 °C (recommended 10 - 25 °C)
Humidity	Non-condensating. Humidity Max 80%	Non-condensating. Humidity Max 80%
Surroundings	Clean laboratory environment	Clean laboratory environment
Feedwater Pressure and Flow Rates		
Feedwater Flowrate	Up to 75 L/hr	Up to 75 L/hr
Mains Drain Requirements	>90 L/hr	>90 L/hr
Minimum Inlet Pressure	2 bar (30 psi)	2 bar (30 psi)
Maximum Inlet Pressure	6 bar (30 psi)	6 bar (30 psi)
Optimum Inlet Pressure	Regulate to 4 bar (LA512)	Regulate to 4 bar (LA512)
Pipe Connections		
Inlet	8mm (5/16) OD Tube	8mm (5/16) OD Tube
Outlet	8mm (5/16) OD Tube	8mm (5/16) OD Tube
Drain	8mm (5/16) OD Tube	8mm (5/16) OD Tube
Reservoir Outlets	8mm (5/16) OD Tube	8mm (5/16) OD Tube
Reservoir Overflow	8mm (5/16) OD Tube	8mm (5/16) OD Tube

II. TECHNICAL SPECIFICATIONS

Technical Specifications

Dimensions and Weights		PURELAB® QUEST RO/DI/UV - PQDIUVM1	PURELAB® QUEST RO/DI - PQDIXXM1
Dispatch Weight		19.6KG	18.5KG
Operational Weight		23KG	21.4KG
Installation		Worktop or Wall Mounting	Worktop or Wall Mounting
Electrical Requirements			
Mains Input		100-240 VAC, 50-60 Hz	100-240 VAC, 50-60 Hz
Power Required (Excluding Pump and UV)		24 V DC	24 V DC
Power Consumption		120 VA	120 VA
Noise Output		dBA - < 40	dBA - < 40
Type 1 (Dispenser Tip)			
Resistivity		18.2MΩ.cm@25°C	18.2MΩ.cm@25°C
Dispenser flow-rate		up to 1.2l/min	up to 1.2l/min
Available Volume*		Up to 10l/day	Up to 10l/day
TOC		<5ppb	<30ppb
Bacteria (LC134 / LC145 / LC197 POU filter Fitted)		<0.1cfu/ml	<0.1cfu/ml
Endotoxin (LC197 POU filter fitted)		<0.001Eu/ml	<0.001Eu/ml
RNases		<1pg/ml	N/A
DNases		<5pg/ml	N/A
pH		Effectively Neutral	Effectively Neutral
Particulates (LC134 / LC145 / LC197 fitted)		0.2µm filtration	0.2µm filtration
Type 2 Water Outlet (Port: 4)			
Resistivity		>1.0MΩ.cm@25°C	>1.0MΩ.cm@25°C
TOC (ppbC)		<50ppb	<50ppb
Bacterial TVC		<100 (cfu/ml)	<100 (cfu/ml)
Available Volume*		Up to 10L/day	Up to 10L/day
Type 3 Water Outlet (Port: 5)			
Conductivity (µS/cm)**		<20 (µS/cm)	<20 (µS/cm)
TOC**		<200ppb	<200ppb
Bacterial TVC**		<1000 (cfu/ml)	<1000 (cfu/ml)
Ionic rejection***		>96%	>96%
Particulates and Bacteria rejection		>99%	>99%
Organic rejection (MW>200 Da)		>99%	>99%
Product flow***		10l/hr	10l/hr
Available Volume		Up to 30l/day	Up to 30l/day

* Available Volume of Type 1 and 2 water, combined; Increased use will reduce purification pack life.

**Subject to suitable feed-water purity (see ionic rejection) and system maintenance.

***With feed water pressure at >4bar and temperature at 15°C

12. WARRANTY / CONDITIONS OF SALE

ELGA Veolia® is a trading name of VWS (UK) Ltd.

General Limited Warranty

VWS (UK) Ltd. warrants the products manufactured by it against defects in materials and workmanship when used in accordance with applicable instructions for a period of one year from the date of shipment for the products. VWS (UK) Ltd. MAKES NO OTHER WARRANTY, EXPRESSED OR IMPLIED. THERE IS NO WARRANTY OF MERCHANTABILITY OR FITNESS FOR A PARTICULAR PURPOSE.

The warranty provided herein and the data, specifications and descriptions of the VWS (UK) Ltd. products appearing in VWS (UK) Ltd. published catalogues and product literature may not be altered except by express written agreement signed by an officer of VWS (UK) Ltd. Representations, oral or written, which are inconsistent with this warranty or such publications are not authorized and, if given, should not be relied upon.

In the event of a breach of the foregoing warranty, VWS (UK) Ltd. sole obligation shall be to repair or replace, at its option, any product or part thereof that proves to be defective in materials or workmanship within the warranty period, provided the customer notifies VWS (UK) Ltd. promptly of any such defect. The exclusive remedy provided herein shall not be deemed to have failed of its essential purpose so long as VWS (UK) Ltd. is willing and able to repair or replace any nonconforming VWS (UK) Ltd. product or part. VWS (UK) shall not be liable for consequential, incidental, special or any other indirect damages resulting from economic loss or property damage sustained by any customer from the use of its products.

Water System Limited Warranty

VWS (UK) Ltd. warrants the water systems manufactured by it, BUT EXCLUDING MEMBRANES AND PURIFICATION PACKS, against defects in materials and workmanship when used in accordance with the applicable instructions and within the operating conditions specified for the systems for a period of one year from the earlier of:

the date of installation, or the 120th day following the date of shipment.

VWS (UK) LTD. MAKES NO OTHER WARRANTY, EXPRESSED OR IMPLIED. THERE IS NO WARRANTY OF MERCHANTABILITY OR FITNESS FOR A PARTICULAR PURPOSE. The warranty provided herein and the data, specifications and descriptions of the VWS (UK) Ltd. systems appearing in VWS (UK) Ltd. published catalogues and product literature may not be altered except by express written agreement signed by an officer VWS (UK) Ltd. Representations, oral or written, which are inconsistent with this warranty or such publications are not authorised and, if given, should not be relied upon.

In the event of a breach of the foregoing warranty, VWS (UK) Ltd. sole obligation shall be to repair or replace, at its option, any product or part thereof that proves to be defective in materials or workmanship within the warranty period, provided the customer notifies VWS (UK) Ltd. promptly of any such defect. The cost of labour for the first ninety (90) days of the above warranty period is included in the warranty; thereafter, labour cost shall be at the customer's expense. The exclusive remedy provided herein shall not be deemed to have failed of its essential purpose so long as VWS (UK) Ltd. is willing and able to repair or replace any nonconforming VWS (UK) Ltd. system or component part. VWS (UK) Ltd. shall not be liable for consequential, incidental, special or any other indirect damages resulting from economic loss or property damage sustained by any customer from the use of its process systems.

Products or components manufactured by companies other than VWS (UK) Ltd. or its affiliates

("Non - VWS (UK) Ltd. products") are covered by the warranty, if any, extended by the Product manufacturer. VWS (UK) Ltd. hereby assigns to the purchaser any such warranty; however VWS (UK) LTD. EXPRESSLY DISCLAIMS ANY WARRANTY WHETHER EXPRESSED OR IMPLIED, THAT THE NON - VWS (UK) Ltd. PRODUCTS ARE MERCHANTABILITY OR FIT FOR A PARTICULAR PURPOSE.

NOTICE

VWS (UK) Ltd. is constantly striving to improve its products and services. Consequently, the information in this document is subject to change without notice and should not be construed as a commitment by VWS (UK) Ltd.

Also VWS (UK) Ltd. assumes no responsibility for any errors that may appear in this document. This manual is believed to be complete and accurate at the time of publication. In no event shall VWS (UK) Ltd. be liable for incidental or consequential damages in connection with or arising from the use of this manual.

VWS (UK) Ltd. warrants its products against defects in materials and workmanship as described in the Warranty statement on the preceding pages.





WARNING!
DO NOT USE - SANITIZATION IN-PROGRESS ,CONTAINS COLD WATER STERILANT.



WARNING!
DO NOT USE - SANITIZATION IN-PROGRESS ,CONTAINS COLD WATER STERILANT.



WARNING!
DO NOT USE - SANITIZATION IN-PROGRESS ,CONTAINS COLD WATER STERILANT.



The Labwater Specialists

ELGA Veolia is the global laboratory water brand name of Veolia. The information contained in this document is the property of VWS (UK) Ltd, trading as ELGA Veolia, and is supplied without liability for errors or omissions. © VWS (UK) Ltd.
2020 - All right reserved. ELGA®, PURELAB® are registered trademarks of VWS (UK) Ltd.

