



DermaGraphix®

IntelliStudio®

Technical Specification

Version 1.0



IMAGING EXCELLENCE FROM



SYSTEM OVERVIEW

Product Description

The DermaGraphix® IntelliStudio® is a photography and photo-archiving system that uses a digital camera along with external light sources to capture photographs of the patient's exposed skin surface creating a matrix of 2D photographs of the patient's body. LED flashes are used as illumination sources for cross-polarized and non-polarized photography options, as well as for video capture. The system is used primarily by dermatologists to document aspects of the patient's body, to map and monitor pigmented lesions, and other distributed skin conditions. Additionally, close-up photographs of small sections of the skin surface can be captured (for example, using a dermatoscope) and tagged/associated to the corresponding skin surfaces on the overview photographs.

Functional Description

The DermaGraphix IntelliStudio camera is mounted to a motorized assembly that moves the camera up and down along the lift column. The patient is instructed to assume various poses to maximize the exposed skin surface on the front, back, left, and right side, as the motorized lift adjusts the camera height to capture photos of the body from head to foot. The resulting matrix of photographs is referred to as a "body map". Additional non-standard poses, such as top of head or soles of feet, may also be captured and added to the body map. The photographs are saved to a patient chart along with any associated close-ups. The photographs can be displayed as thumbnails in "dashboard" view, which provides a comprehensive photographic history of the patient from baseline through all subsequent photography sessions. The user interface allows users to tag and annotate small sections of the skin surface. It also provides a method to compare body maps and close-up photos of the same patient across different views and time-points.

Product Application

The primary application of the DermaGraphix IntelliStudio System is to generate anthropometric 2D data sets that accurately represent a person's skin texture and color. The data will be used to review the condition of the skin during the initial examination as well as to track changes to the skin condition over time.

SYSTEM MEASUREMENTS*

*Measurements subject to change

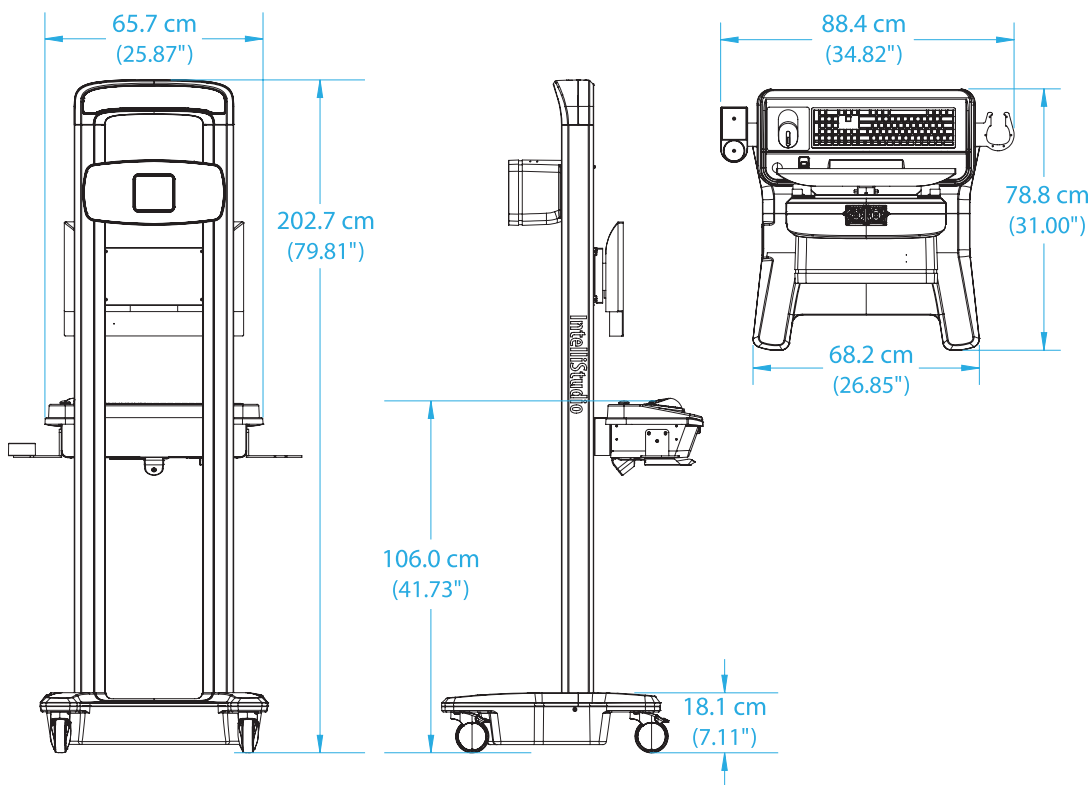

FACILITY REQUIREMENTS

Minimum System Space Requirements

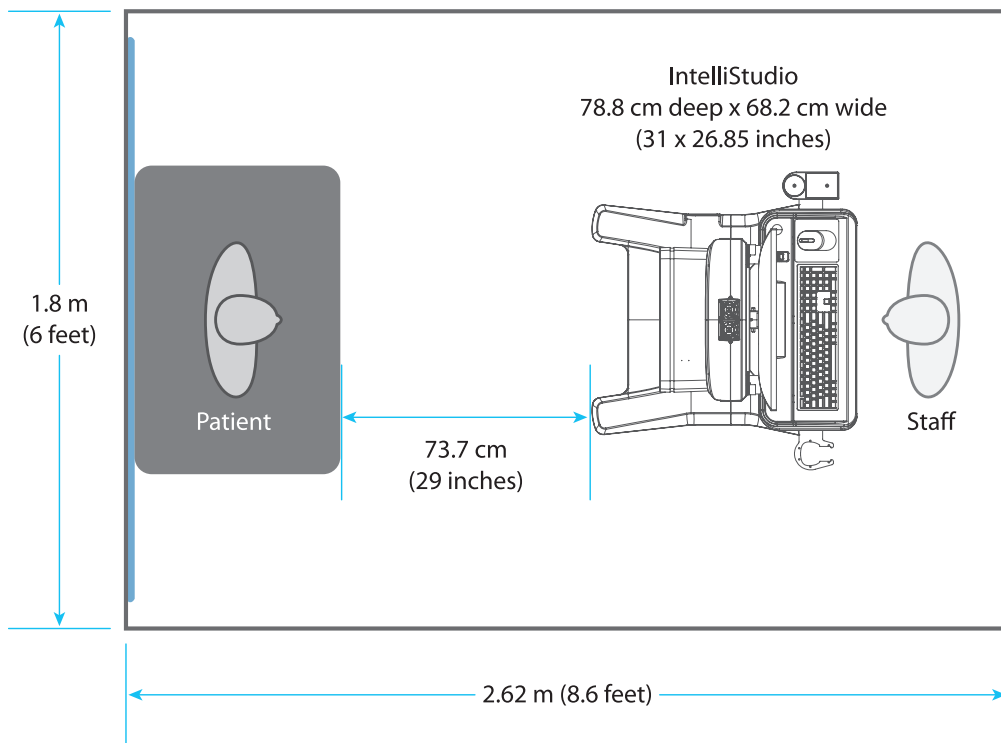

Minimum ceiling height: 2.3 m (7.5 feet)

SPECIFICATIONS

IntelliStudio system weight

Without extra monitor: 88 kg

With optional extra monitor: 95 kg

System power, fuse and cord ratings

- **Power** 100–120VAC 50/60HZ or
220–240VAC 50/60Hz
- **Fuse** F10AL 250V
- **Power cord** for 120VAC system: 10A 125VAC
for 230VAC system: 10A 250VAC

Power cord must comply with local and federal regulations and be approved for medical device usage.

Class 1 Laser Product

IEC 60825-1: 2014

Max output of laser radiation is less than 10mW

Capture Computer

- Dell OptiPlex with 24" touch screen display
- CPU: Intel i9 10 core CPU
- RAM: 32 GB RAM
- Storage: 2TB M.2 NVMe SSD
- GPU: NVIDIA GeForce GTX 1650
- Keyboard and mouse
- Windows 10 64 bit Pro

Network Requirements

- 1 Gbps connectivity (or higher)
(Wi-Fi / wireless is **not supported**)

Additional Facility Considerations

- IntelliStudio comes equipped with image capture lighting. Normal office lighting is needed for patient positioning. No additional lighting is needed.
- If not using Canfield supplied backdrop, the recommended paint color for the wall behind patient: Home Depot Behr 550D-5 Ocean Cruise—Flat Finish

OPTIONAL EQUIPMENT (NOT SUPPLIED)

Additional Workstation Recommendations (not supplied)

- Operating system: Windows 10 or 11 Professional, 64 bit
NOT SUPPORTED: Windows Home Edition, Windows VISTA
- Processor: 2.2Ghz Quad Core i5, 7th Gen or higher
 - Intel i7 7th Gen or higher, recommended
 - AMD CPUs **not supported**
- GPU: If workstation will also be used to view 3D images, a 2GB GPU is required (Nvidia recommended)
- System memory (RAM): 32 GB or greater
- Minimum 2 GB available disk space for installing application
- Minimum 1 TB available disk space recommended for data
- Display: 1920 x 1080 minimum, 2560 x 1440 recommended (4K displays not currently optimized)
- Microsoft Security Essentials anti-virus software recommended
- Wired printers (recommended for speed)
- 1 Gbps Ethernet connection for networking (Wi-Fi / wireless is **not supported**)

Server / Network (not supplied) Minimum Recommendations

- Windows Server 2016 64-bit, Server 2019 64-bit
- Microsoft SQL Server 2016, 2017 and 2019 (Express edition is installed by default)
- 2.2 GHz or faster processor
- 16GB system memory (RAM)
- 1 Gbps wired LAN connectivity (Wi-Fi not supported)
- 1 Terabyte HDD minimum recommended. *Space required is dependent upon patient volume, camera used, and settings.*
 - **On average, 1 TB per 1100 patient sessions is required.**
 - NAS and virtual servers *are* supported
- RAID 1 — NOT SUPPORTED
- Regularly scheduled backups are highly recommended

Notes

- You are ***not required*** to purchase a server for DermaGraphix® or Mirror® to operate.
- We do not support using a server class OS as a workstation.
- Workstation based cloud licensing

technical support
phone (USA): 1.800.815.4330
phone: +1.973.434.1201
techsupport@canfieldsci.com

IMAGING EXCELLENCE FROM



4 Wood Hollow Road, Parsippany, NJ 07054 USA • fax +1.973.887.0784 • www.canfieldsci.com

3D SOLUTIONS • FACIAL IMAGING & ANALYSIS • IMAGING SOFTWARE • PHOTOGRAPHY • RESEARCH SYSTEMS & SERVICES • TRAINING

IntelliStudio and DermaGraphix are registered trademarks of Canfield Scientific, Inc. Copyright © 2023 Canfield Scientific, Inc.