



BUTTERFLY VALVES

Installation, operation and maintenance manual



Contents

1. General	4
2. Valve identification	5
3. Unloading and storage	6
4. Valve installation	8
4.1 Valve location in the pipeline	10
4.2 Installation positions of the valve	11
4.2.1 Installation in a horizontal pipeline	12
4.3 Pipeline supports and pipeline reducers	13
4.4 Installation at end of pipeline	14
4.5 Welding procedures	15
4.5.1 Installation in a vertical pipeline	16
4.5.2 Welding with connection pipes (recommended method)	16
4.6 Installation of valve with flanged connections	17
4.7 Before commissioning	18
4.8 Flushing	18
4.9 Commissioning	19
4.10 Pressure test	19
5. Actuator disassembly and installation	20
5.1 Removing the actuator	20
5.2 Changing the actuator installation position	21
5.3 Actuator installation	21
5.4 Electric actuator	21
5.5 Hydraulic actuator	21
5.6 Actuator installation positions	22
6. Maintenance	24
6.1 Replacing the stem O-ring seal (BFS/BRS valves)	25
6.2 Replacing the stem graphite packing (BFC/BRC model)	26
7. Appendices	27
7.1 Parts list for BFS/BRS models	27
7.2 Parts list for BFC/BRC models	28
7.3 Type code	29
7.4 Coupling dimensions, BFS/BRS models	30
7.5 Coupling dimensions, BFC/BRC models	31



NOTE:

This manual must be read and its instructions must be followed when installing, operating and/or performing maintenance on the valve as well as its manual gear or actuator.

These instructions are of general nature and do not cover all possible operating scenarios. For more specific guidance on the installation, operation and maintenance of the valve or its suitability for an intended use, please contact the manufacturer.

Vexve Oy reserves the right to make alterations to these instructions.

Vexve Oy is not responsible for damages caused by incorrect transportation, handling, installation, operation or maintenance. Furthermore, Vexve Oy is not responsible for damage caused by foreign objects or impurities.

Warranty

Warranty according to Vexve Oy's "General terms and conditions of sale".

The warranty covers manufacturing and material faults. The warranty does not apply to damages caused by inappropriate installation, operation, maintenance, or storage ie. these instructions must be followed for the warranty to apply. Vexve Oy requires that any faulty products under warranty are to be returned to the factory for inspection. Only after the product has been found faulty, Vexve Oy can grant compensation.

Please refer to Vexve Oy's "General terms and conditions of sale" for detailed warranty clauses. The document is available from the manufacturer.

Warnings and symbols

Ignoring the warnings and symbols may lead to serious injury or equipment damage. Persons authorized to use the equipment must be familiar with the warnings and instructions.

Appropriate transportation, storage and installation as well as careful commissioning are essential to ensure faultless and stable operation.

The following symbols are used in this manual to draw attention to actions essential to ensure the proper use and safety of the device.



Meaning of the symbol: NOTE

The NOTE symbol is used for actions and functions that are essential for the proper use of the device. Ignoring this symbol may have harmful consequences.



Meaning of the symbol: WARNING

The WARNING symbol is used for actions and functions that, if carried out incorrectly, may lead to injury or equipment damage.

1. General

Vexve Oy's butterfly valves are high performance, metal seated, triple offset type butterfly valves designed especially for district heating and district cooling applications. Vexve's high quality butterfly valves with total bi-directional tightness can be used for shut-off (on/off) and control purposes. Vexve provides models BFS and BRS for shut-off and models BFC and BRC for control purposes.

Vexve's butterfly valve can be used within the following temperature-pressure range. Please note that the maximum allowable working pressure is dependent on the operating temperature.

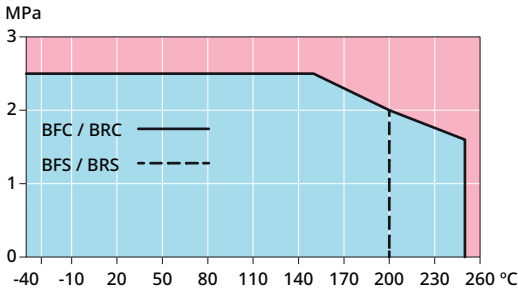

Chart 1. Pressure-temperature chart

	Ambient temperature	Medium temperature
BFS	-40...+60	-40...+200
BFC	-40...+60	-40...+250

Note!

DN 1200–1600 temperature range
-20...+200 °C

The maximum allowable working pressure is dependent on the operating temperature



NOTE:

When intending to use the valve for other media or applications please contact Vexve Oy to ensure its suitability.

Parts lists for Vexve Oy's steel ball valves are presented in Appendices 7.1 and 7.2

For detailed technical information including dimensions and weights, torques, Kv-values etc please refer to Vexve's Product catalogue or data sheets (www.vexve.com) for the valve in question.

2. Valve identification

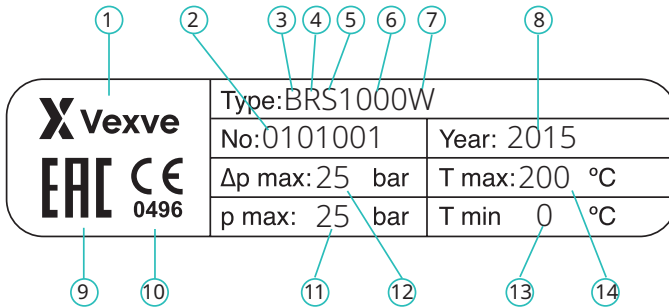

- | | |
|---|---|
| <ol style="list-style-type: none"> 1. Valve manufacturer 2. Valve product number, which is individual valve number 3. Valve type:
B = butterfly valve 4. Product group:
F = full bore
R = reduced bore 5. Valve use
S = shut-off valve
C = control valve 6. Valve size (DN) | <ol style="list-style-type: none"> 7. Connection to the pipeline:
W = welding ends
F = flanged ends 8. Manufacturing year 9. Eurasian Conformity Valve Certification 10. CE marking and ID of the notified body 11. Pressure class 12. Maximum pressure difference when the valve is closed 13. Minimum operating temperature 14. Maximum operating temperature |
|---|---|

The *type code* for Vexve's butterfly valves is presented in Appendix 7.3.

3. Unloading and storage

Check that the contents of the delivery is as ordered. Check that the valve and related equipment have not been damaged during transportation.

Store the valve carefully before installation, preferably in a well-ventilated, dry space, on a shelf or a wooden grid to protect it from rising damp (see figure 5).

Protect bare metal surfaces, shaft parts, and flange surfaces with anti-corrosive agent before storage.

The valve must be transported to the installation site in a sturdy package. Do not remove the flow port protectors before installation. Protect the valve from sand, dust, and other impurities.

The valve must always be lifted by its lifting lugs and upper neck (see Figures 3 and 4). The valve or valve assembly must not be lifted from the actuator (see Figure 2). Even light knocks may damage the actuator or affect the actuator and valve adjustments.



NOTE:

Take the weight of the valve into account when handling it.

When delivered, the valve is in the open position. During storage, the valve must also be in the open position.

Maximum recommended storage time is two years. If the valve is stored for more than two years, it should be operated and cleaned yearly.

Packaging:

Vexve's products are protected during transportation with special packaging. The packaging consists of environmentally friendly materials that are easy to sort and recycle.

Recycling the packaging materials at designated waste collection points is recommended.

The following packaging materials are used: wood, cardboard, paper, and polyethylene sheets.

Recycling and disposal

Nearly all parts of the valve are made of recyclable material. The material type is marked on most parts. The valve is delivered with a material list, and separate recycling and disposal instructions are available from the manufacturer. The valve can also be returned to the manufacturer for recycling and disposal against a fee.

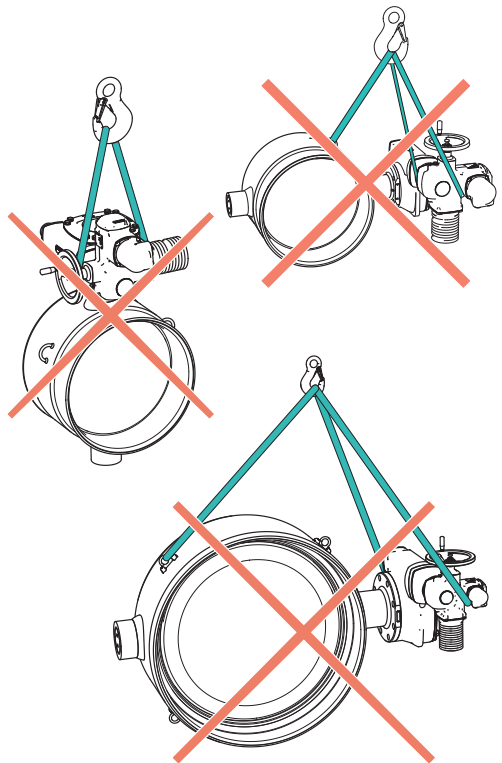

Figure 2. Do not lift the valve by the actuator

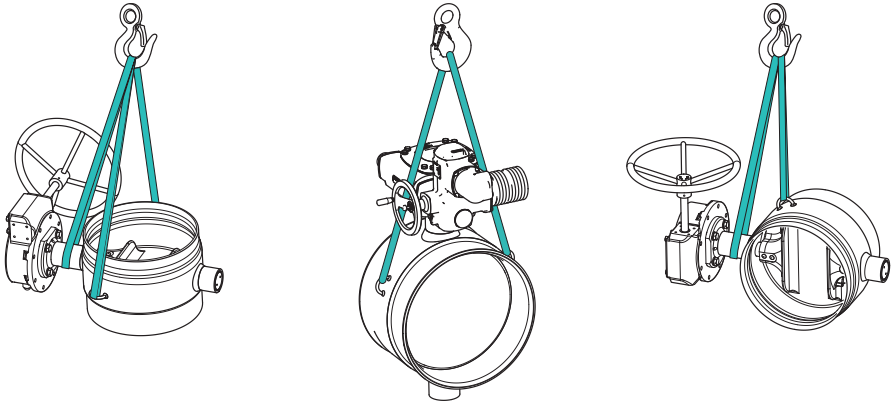

Figure 3. Lifting a valve equipped with 2 lifting lugs

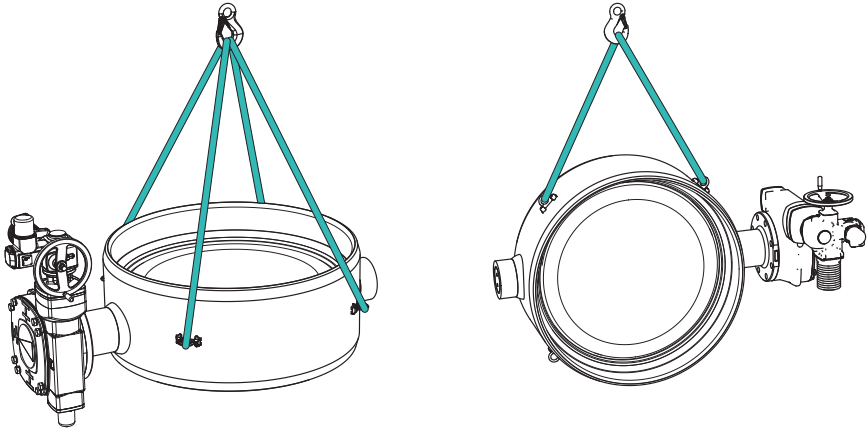

Figure 4. Lifting a valve equipped with 4 lifting lugs

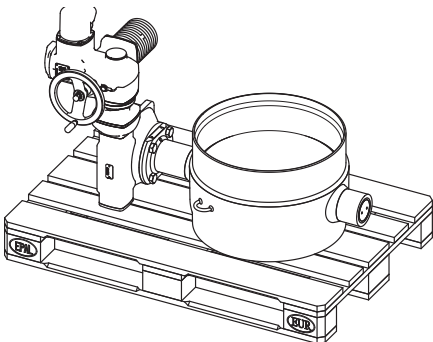

Figure 5. Storage

4. Valve installation



WARNING:

Incorrect installation may result in serious personal injury and it may damage or cause malfunction of the equipment. These instructions must therefore be followed carefully when installing the valve.

These general instructions do not cover all possible operating scenarios. For more specific guidance on the use of the valve or its suitability for an intended use, please contact the manufacturer.

- Do not remove the flow port protectors before installation. Keep the valve protected from sand, dust and other impurities.
- If the valve was delivered with the actuator installed, avoid removing the actuator during installation.
- Incorrect re-installation or adjustment of the actuator will result in a high risk of damage and leakage.
- Exercise extreme caution when testing the valve before installation in the pipeline.
- The valve or valve assembly must not be lifted by the actuator. If the valve is equipped with lifting lugs, use the lugs (see Figures 3 and 4). Dropping or incorrect lifting of the valve can result in personal injury or equipment damage.
- Use one of the allowed lifting methods shown in Figures 3 and 4.

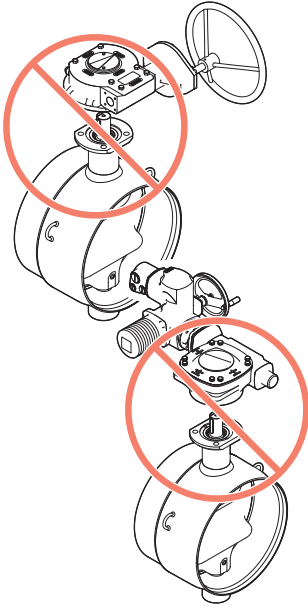

Figure 6. Do not remove the actuator

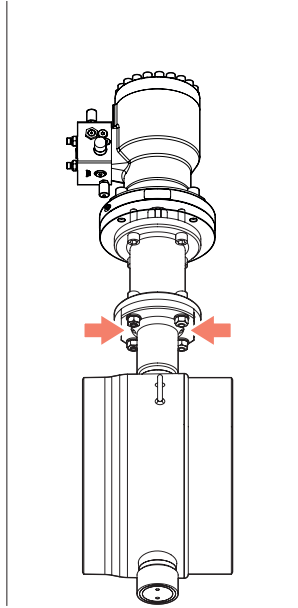

Figure 7. The holes in the flange must be plugged before insulation

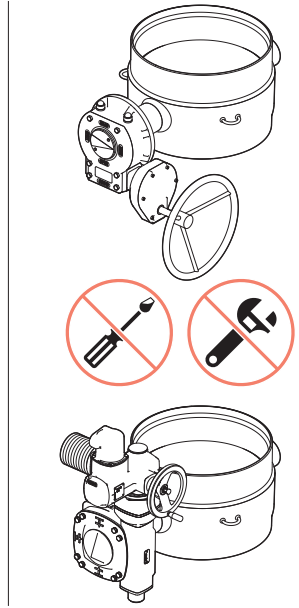

Figure 8. Do not change factory settings

Prior to installation:

1. Remove the flow port protectors
2. Clean the pipes and the valve, see Figure 9
3. Close the valve fully before welding or installing it in the pipeline.
The valve must remain closed for the entire installation procedure!



WARNING:

Pipeline and valve shall be carefully cleaned prior to installation as any welding debris or other impurities can damage the valve.

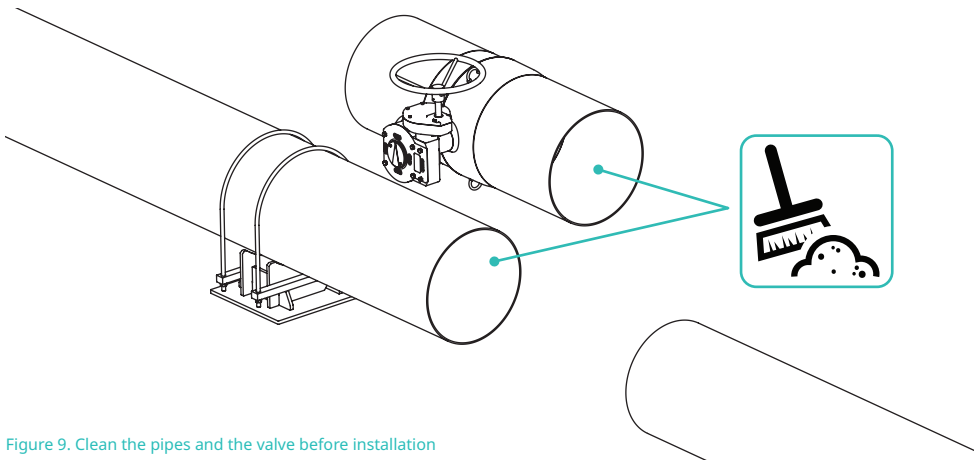

Figure 9. Clean the pipes and the valve before installation

Valve installation:

1. Check the instructions for the correct location of valve in the pipeline, see chapter 4.1
2. Install the valve in an allowed position, see chapter 4.2
3. See chapter 4.5 for installation instructions of valve with welding ends
4. See chapter 4.6 for installation instructions of valve with flanges



NOTE:

The valve must be used only in applications for which it is intended.

4.1 Valve location in the pipeline

Valve should be installed as far as possible from the components causing turbulence, such as pumps, pipe bends and pipe connections.

Minimum installation distances shown in figure 10 should be followed.

- 1 Pipe bend axis
- 2 Stem axis
- 3 Pumps shaft axis

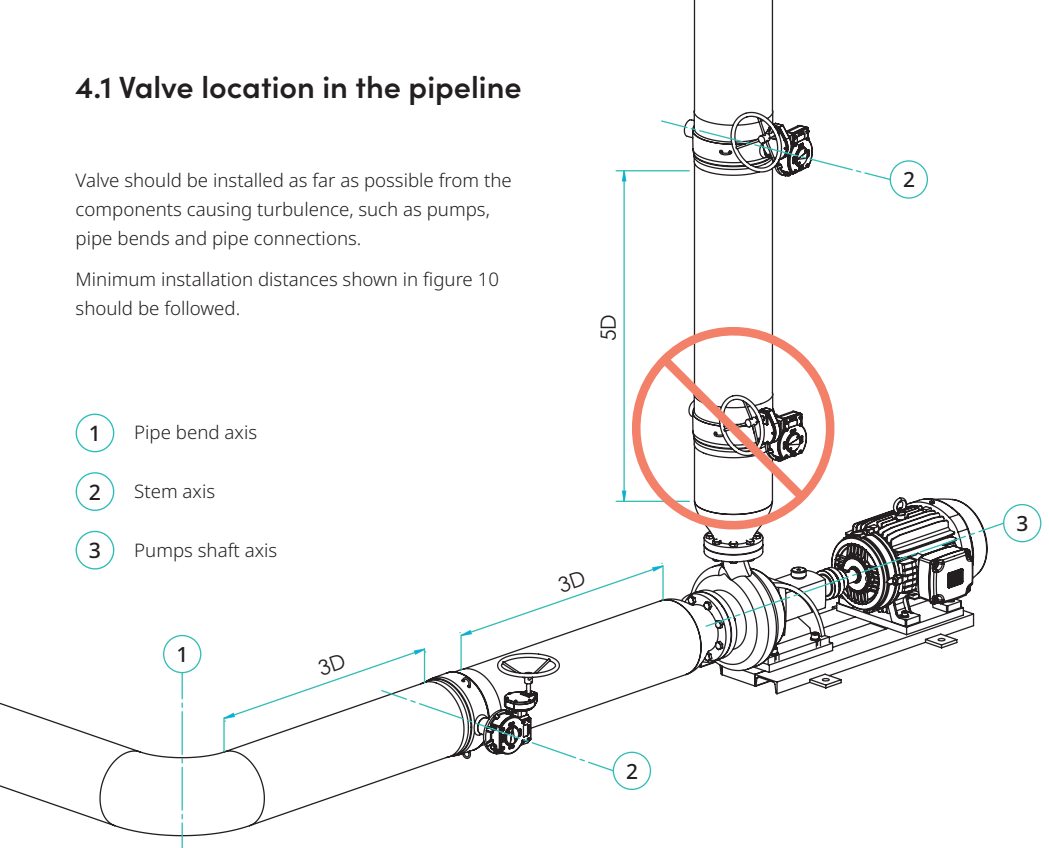

Figure 10. Minimum distances, D = pipeline diameter



NOTE:

Valve should not be installed in such sections in the pipeline where impurities can easily be piled. For example lowest sections of the pipeline should be avoided (see figure 11).

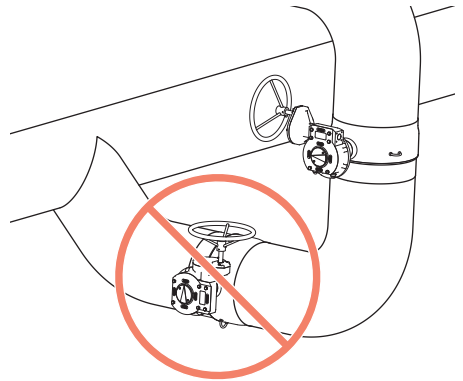

Figure 11. Valve location

4.2 Installation positions of the valve

Valve can be installed in a vertical (see figure 12, section 1), horizontal (2) or diagonal (3) pipeline.



NOTE:

See chapter "4.2.1 Installation in a horizontal pipeline" for more specific instructions for installation in a horizontal (2) or diagonal (3) pipeline.

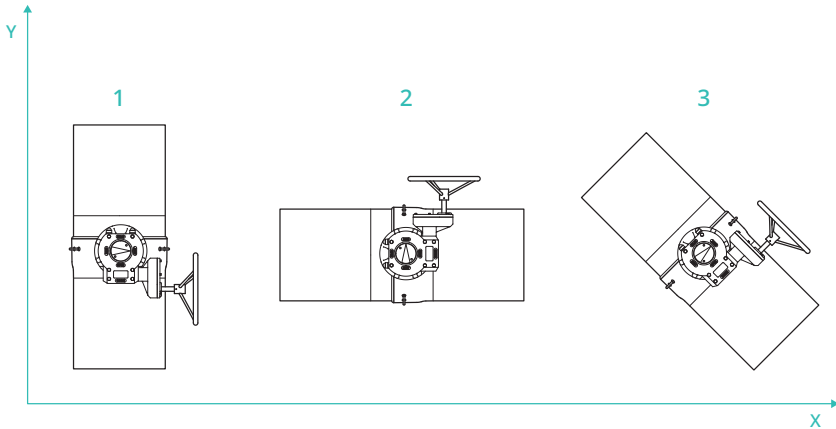

Figure 12. Possible installation positions of the valve

After a pipe bend valve should be installed so that the stem axis is perpendicular to the pipe bend axis, see figure 10.

Especially a control butterfly valve should be installed after a centrifugal pump so that stem axis is at 90° angle in relation to the pump shaft axis, see figure 9. However, if two valves are installed one after the other, the stems must be perpendicular to each other.

When installed this way, the loading on the valves is more even and vibration that may otherwise be present will not be generated.

4.2.1 Installation in a horizontal pipeline

The most recommendable installation position is in a horizontal pipeline with the valve stem horizontal (see Figure 13). The valve can alternately be installed at an angle of max $+60^\circ$ (see Figure 14).

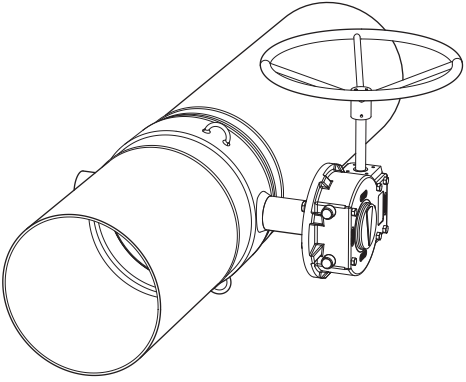

Figure 13. Installation in a horizontal position

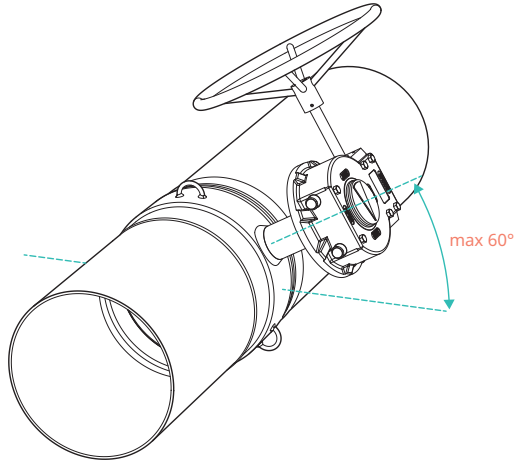

Figure 14. Installation at an angle

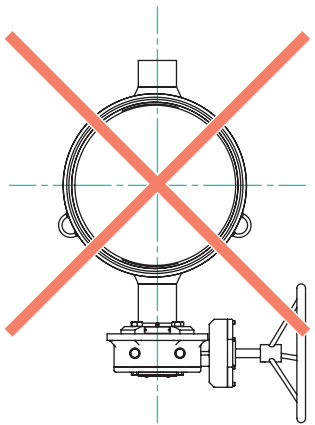
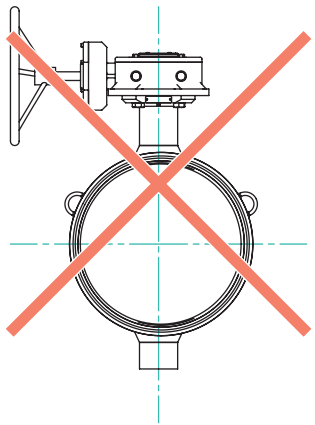

Figure 15. Not recommended positions

4.3 Pipeline supports and pipeline reducers

Pipeline supports should not be installed under the valve!

If pipeline reducers are used in connection with the valve, additional pipeline supports must be used because of the higher mechanical load on the valve (see figure 16).

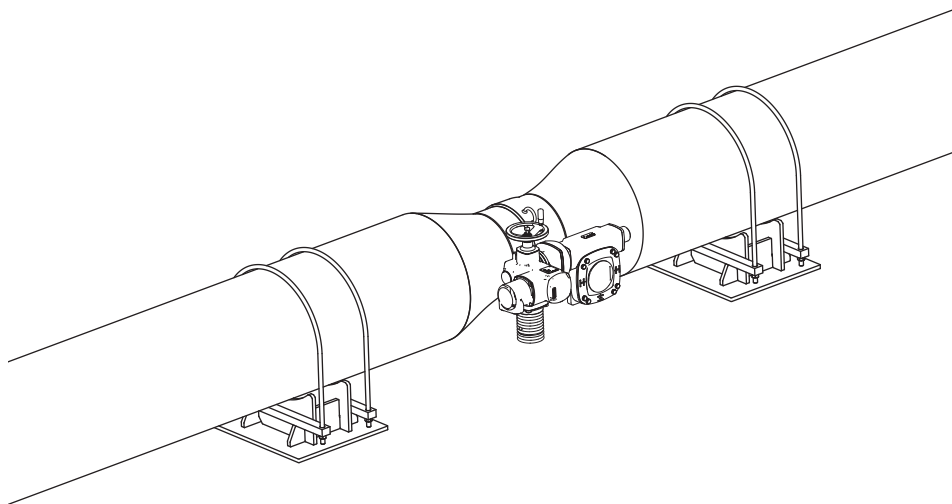

Figure 16. Pipeline supports

4.4 Installation at end of pipeline



NOTE:

Do not use the valve at the end of the pipeline – a blank flange must always be installed after the valve (see Figures 17 and 18.).

When the valve is installed at the end of the pipeline, there is a risk of corrosion-causing oxygen-rich water or air collecting in the empty rear side of the valve. To prevent corrosion, the space after the valve must be filled with oxygen-free water.

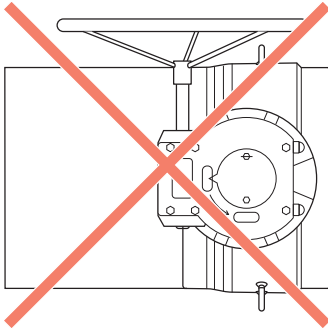

Figure 17. Do not use the valve at the end of the pipeline

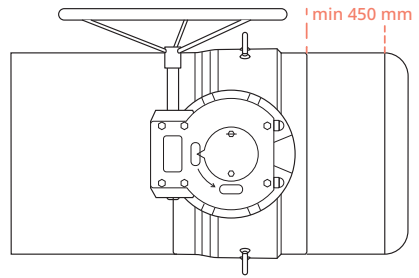

Figure 18. Blank flange.

Min. 450 mm pipe must be installed between the valve and the blank flange



NOTE:

If the valve is located near to the blind flange at the end of the pipeline, valve must not be fully closed. Instead the valve must remain slightly open to prevent a closed space from forming between the valve and blind flange. If water in the closed space expands (for example due to temperature), it may damage the valve.

4.5 Welding procedures



NOTE:

Electric welding must be used to weld the valve in place.

- Recommended welding method is manual metal arc welding. Recommended welding rod is ESAB OK 48.00 or equal (standard: EN ISO 2560-A; classification: E 42 4 B 42 H5).
- Valve may be welded only by an authorized mechanic, following valid norms and standards.
- The valve must remain closed during installation and welding to ensure that welding residue does not damage the seal surfaces.
- The ends of the pipes must be parallel to the valve and correctly aligned.
- The length of the valve must be the same as the distance between the pipe ends, taking into consideration the welding gaps.
- Diameter and wall thickness of the pipes must be compatible with the welding ends of the valve.
- It is recommended to install the valve so that the main flow direction is same as the recommended flow direction for the valve.
- The recommended installation position for the valve is at an angle (see Figure 20.) or with the shafts in the horizontal position (see Figure 19.). Avoid installation with the shafts fully upright.

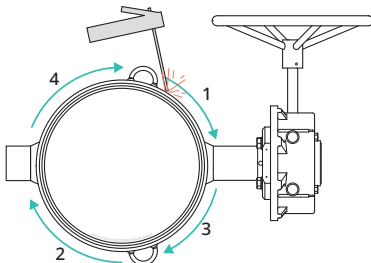

Figure 19. Welding the seams



NOTE:

The greatest angle between stem axis and horizontal axis is 60 degrees (see Figure 20.).

- The valve must first be bridged to the pipeline using spot welding, with 4-8 seams alternately on opposite sides of the valve.
- Then the seams between the bridges are welded as shown in Figures 19. and 20. Welding order: 1-2-3-4.
- Any lid welding must be carried out at a minimum of 200 mm from the valve seam.
- During welding the ground must be connected to the pipe of the valve body or the pipeline. Ground cable should be connected to the pipe on the same side as the welding seam. Otherwise the current may damage the valve seal. Never connect the ground to the valve neck, actuator flange or actuator.

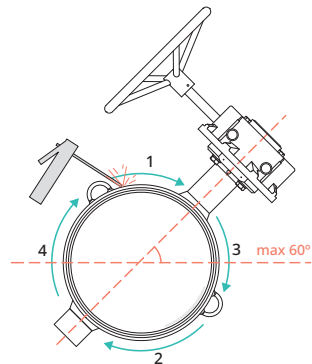

Figure 20. Welding the seams

4.5.1 Installation in a vertical pipeline

If the valve is welded to a vertical pipeline, close the valve and cover the seal and disc with a water cushion of at least 40 mm (see Figure 21.).

The water protects from welding spatters that may damage the seal and disc surfaces during welding.

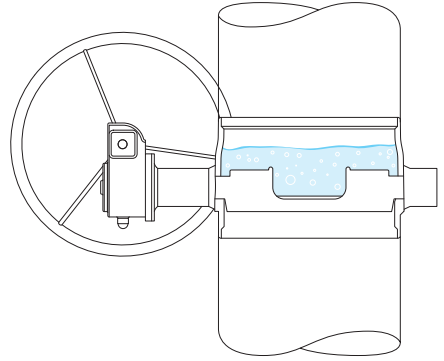

Figure 21. Cover the seal and disc with a water cushion of minimum 40 mm

4.5.2 Welding with connection pipes (recommended method)

- The recommended method of welding the valve to the pipeline is welding with connection pipes (see Figure 22.). Tack welding and the welding order for the seams are the same as in Figures 18. and 19. Welding order: 1-2-3-4.
- The valve must remain closed during installation and welding to ensure that welding residue does not damage the seal surfaces.
- This also facilitates cleaning of the inner surfaces from welding residue and impurities.

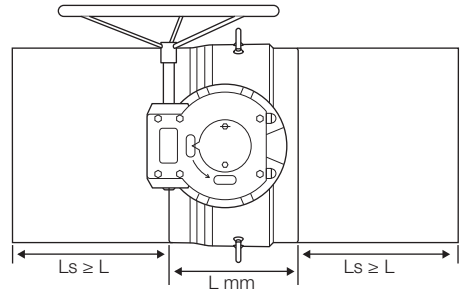

Figure 22. The recommended method

4.6 Installation of valve with flanged connections

- Valve may be installed only by an authorized mechanic, following valid norms and standards.
- The valve must remain closed during installation to ensure that any residue or dirt does not damage the sealing faces.
- The sealing faces of the pipe flanges must be parallel to the valve sealing faces and correctly aligned.
- The length of the valve must be the same as the distance between the flanges in the pipe line, taking into consideration the gasket.
- The flanges in the pipeline must be compatible with valve flanges. For detailed information please refer to the standard EN1092-1.
- The bolts and nuts used on installation must be selected to match operating conditions on installation location. Bolts and nuts must also fulfill requirements of the pressure, temperature, flange material and gasket. For detailed information please refer to the standards EN 1515-1, EN1515-2 and 1515-4.
- The gasket used on installation must be selected to match operating conditions, temperature, pressure and medium. Gasket dimensions must be compatible with sealing faces of the flanges. For detailed information please refer to the standard EN1514.
- It is recommended to install the valve so that the main flow direction is same as the recommended flow direction for the valve.
- The recommended installation position for the valve is at an angle (see Figure 13.) or with the shafts in the horizontal position (see Figures 13 and 23). Avoid installation with the shafts fully upright.

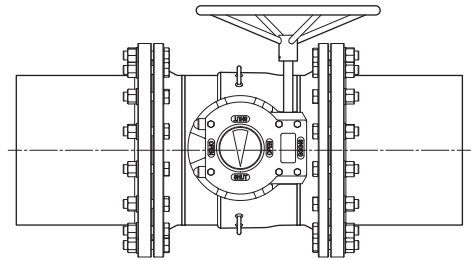
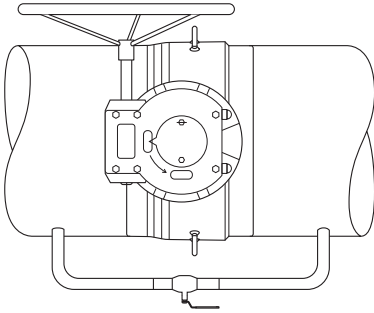

Figure 23. The recommended method

4.7 Before commissioning

It is recommended to fill the pipeline via by-pass valves in order to avoid pressure shocks and to reduce forces caused by opening the butterfly valve under pressure (see Figure 24.).



To avoid pressure shocks and to reduce the forces caused by opening the valve under pressure, a by-pass valve must be used in connection with butterfly valves (see Figure 24.).

Figure 24. By-pass valve



NOTE:

- It is recommended to fill the pipeline via by-pass valves.
- The pipeline must be flushed carefully, see chapter 4.8 for instructions

4.8 Flushing

Pipeline needs to be flushed carefully after the valve installation.

Before starting the flushing, turn the valve disc so that the opening angle is 30–40°.

Close the valve gradually during the flushing until the opening angle is approximately 5–10°.

Decreasing the opening angle increases the velocity of the flow through the valve. This produces efficient removing of impurities from sealing surfaces of the valve.

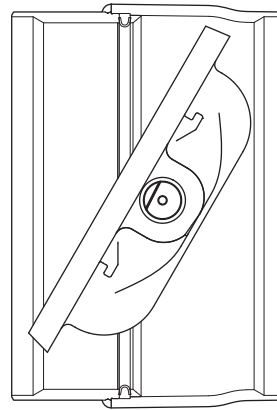

Figure 25. Pipeline needs to be flushed after valve installation

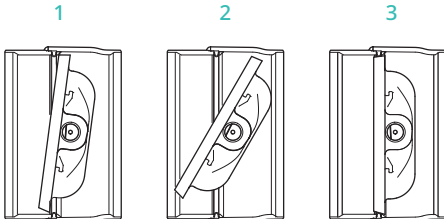

Figure 26. If the opening angle is small, it is recommended to perform flushing before closing the valve



NOTE:

It is recommended to perform the flushing also before closing the valve after it has been used for control purposes so that the opening angle has been small (10° or less), see Figure 26.

4.9 Commissioning

During commissioning the opening angle of the valve should be at least 15 degrees. This is to reduce the effect of any pressure shocks on the valve.

4.10 Pressure test

Exceeding the permitted values marked on the valve may damage the valve and, in the worst case, cause uncontrolled venting of the pressure. This leads to equipment damage and possibly also to personal injuries.

- The greatest permitted test pressure against a closed valve is $1.1 \times PN$ (PN = valve's max. trim ΔP). When carrying out a pipeline pressure test ($1.5 \times PN$), the valve must be fully open. The tightness of the valve can be ensured after this.

- If the stem is equipped with graphite packing (BFC/BRC models), the tightness of the packing should be checked. If required, the graphite packings are tightened with the hexagonal nuts until they no longer leak. Do not over-tighten the packings as this increases the valve torque.

5. Actuator disassembly and installation



NOTE:

Avoid removing the actuator from the valve. The actuator has been calibrated at the factory to ensure that the valve is tight. If the actuator is removed, the actuator may have to be re-calibrated.

Vexve Oy accepts responsibility only for actuators installed by Vexve or Vexve certified installers.

Refer to the separate adjustment instructions, available from the manufacturer.



WARNING:

Due to dynamic torque, the actuator must not be disconnected from the valve in a pressurised pipeline.

Incorrect disconnection may cause serious personal injuries as well as malfunction and damage to the equipment. Extreme caution must be exercised during disconnection.

Do not turn the disc more than 90° as this may damage the seal. Due to the valve structure, the disc can only be turned within its original range of 0–90 degrees.

5.1 Removing the actuator

- Keep the valve and the pipeline non-pressurised whenever the gearing is not connected.
- In a butterfly valve, the gear functions as a limiter for the open and close positions. The valve itself is not equipped with limiters. The manual gears used with butterfly valves are self-locking manual gears.
- Close the valve fully with the handwheel when the manual actuator is being disconnected. (The valve is closed by turning the actuator handwheel clockwise.)
- Turn the actuator handwheel slightly anti-clockwise to reduce the force of the actuator and the valve. Now the handwheel will turn easily.
- Remove the actuator bolts and pull the actuator out. Use an extractor, if required.

5.2 Changing the actuator installation position

When the installation position is changed, the actuator must be disconnected from the valve shaft and turned 180°. The closed position limit must be re-adjusted according to the relevant instructions. These are available from the valve manufacturer.

In manual use, the valve must close when the handwheel is turned clockwise. Do not turn the disc more than 90° as this may damage the seal.

5.3 Actuator installation

Make sure the valve is in the closed position.

Install the actuator such that the handwheel is in the desired direction. Make sure that the stem is in the original position in relation to the actuator or that it is turned 180°.

Visually check that the actuator is straight in relation to the valve. Fasten all mounting screws as tight as possible. Set the mechanical limits for the closed position.

The opening angle of the valve is 90°.

5.4 Electric actuator

Please refer to the separate installation/adjustment instructions, available from the manufacturer.

5.5 Hydraulic actuator

Please refer to the separate installation/adjustment instructions, available from the manufacturer.

5.6 Actuator installation positions

Butterfly valve / manual gear, default position AR, see Figure 27.

Butterfly valve / electric actuator, default position ABR, see Figure 28.

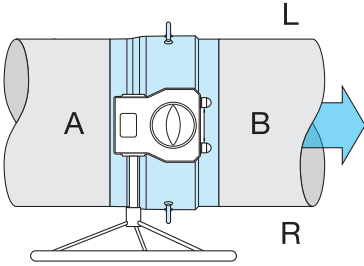

Figure 27. Installation position AR

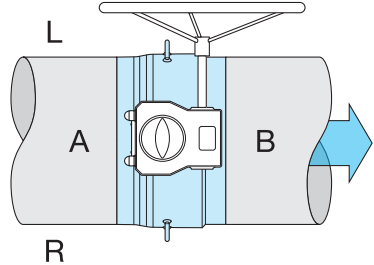

Figure 28. Installation position AL

Code	The location of the handwheel in relation to the flow direction (seen from valve A side)
AR	R Location of the handwheel on the right side
AL	L Location of the handwheel on the left side

Actuator installation positions:
butterfly valve / manual gear, butterfly valve / electric actuator

Butterfly valve with actuator will be delivered in ABR position as a standard. Please inform us, whether you want to have another option when placing an order.

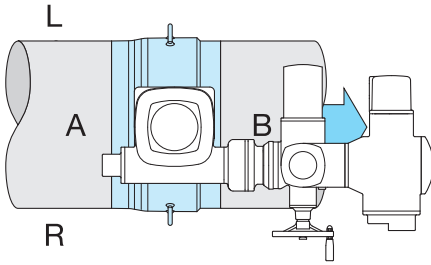

Figure 29. Installation position ABR

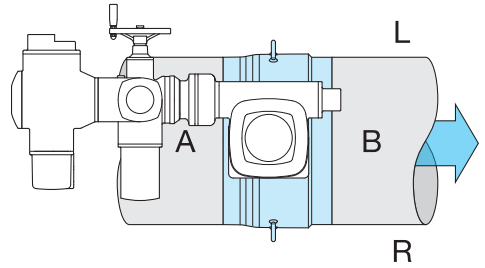

Figure 30. Installation position AAL

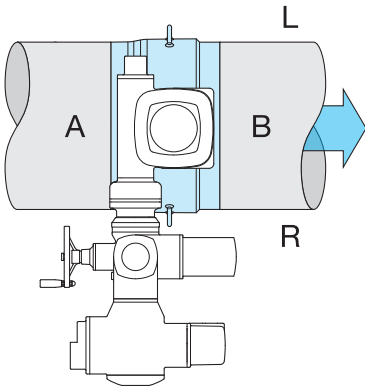

Figure 31. Installation position ARA

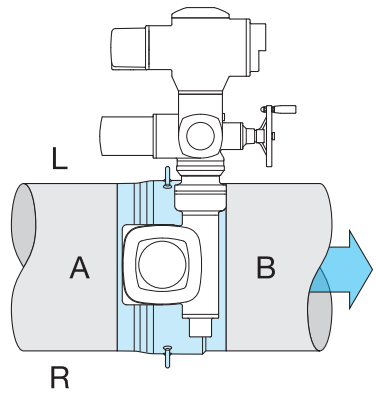

Figure 32. Installation position ALB

6. Maintenance

Vexve butterfly valves are virtually maintenance-free.

Correct choice of valve as well as careful installation, commissioning, and use significantly reduce any need for maintenance.



WARNING:

When the valve is installed in the line, its surface temperature may be dangerously high. Protect yourself against burns.

We recommend checking the following periodically:

Check that the valve is free of surface damage and shaft leaks, and carefully repair any damage. To ensure long-term operational reliability, even when seldom used (around ten times a year or less), we recommend the following:

Approximately six months after commissioning and then once a year, inspect the valve for shaft leaks, check the manual gear / electric actuator / hydraulic actuator, and ensure the tightness of the screws between valves.



NOTE:

Impurities in the pipeline, wear, and damage caused by pressure shocks are the most common reasons for leaks through the sealing surfaces of the valve. Impurities can be removed.

Close the valve gradually until the disk is open by 5–10 degrees. The increased flow rate effectively dislodges any solid impurities and cleans the sealing surfaces.

6.1 Replacing the stem O-ring seal (BFS/BRS valves)



WARNING:

Do not remove or disassemble a pressurised valve!

- Make sure that all spare parts needed for maintenance are available.
- Keep the valve and the pipeline non-pressurised whenever the gear is not connected.
- Remove the actuator as instructed in chapter 5.
- Disconnect the key (3) from the stem (5).
- Remove the retaining ring (1).
- Pull the O-ring sleeve (2) out using an extraction tool. Check that the stem is intact, and clean it carefully.
- Lubricate the O-rings with, for example, Würth HHS2000 lubricant spray. Replace the O-rings on the O-ring sleeve.
- Check that there are no sharp edges on the place for the key groove, elsewhere on the stem, or on the stem sleeve, as these could damage the O-rings during installation. Hone or tape over any sharp edges if necessary.
- Push the O-ring sleeve back in place. We recommend using an insertion tool.
- Re-insert the retaining ring and the key.
- Install the actuator as instructed in chapter 5.

For Part numbers please refer to *Parts list*, Appendix 7.1.

6.2 Replacing the stem graphite packing (BFC/BRC model)



NOTE:

BFC/BRC valves do not require regular maintenance. The tightness of the graphite stem packing should be checked once in a while. If the graphite packing leaks, the packing should be tightened with the tightening nuts. In the assembly picture for the BFC model (see appendix 7.2), the tightening nuts for the graphite packing have been marked with number 1.

- Make sure that all spare parts needed for maintenance are available.
- Keep the valve and the pipeline non-pressurised whenever the gear is not connected.
- Remove the actuator as instructed in chapter 5.
- Disconnect the key (8) from the stem (9).
- Remove the clamping bush (4).
- Remove the sliding bearing (5).
- Remove the sealing rings (6).
- Clean the shaft, especially the area in contact with the clamping bush seals.
- Install the new sealing rings.
- Re-install the sliding bearing and the clamping bush.
- Install the actuator as instructed in chapter 5.

For Part numbers please refer to *Parts list*, Appendix 7.2.

7. Appendices

7.1 Parts list for BFS/BRS models

Valves made before 6/2020 have only one key.

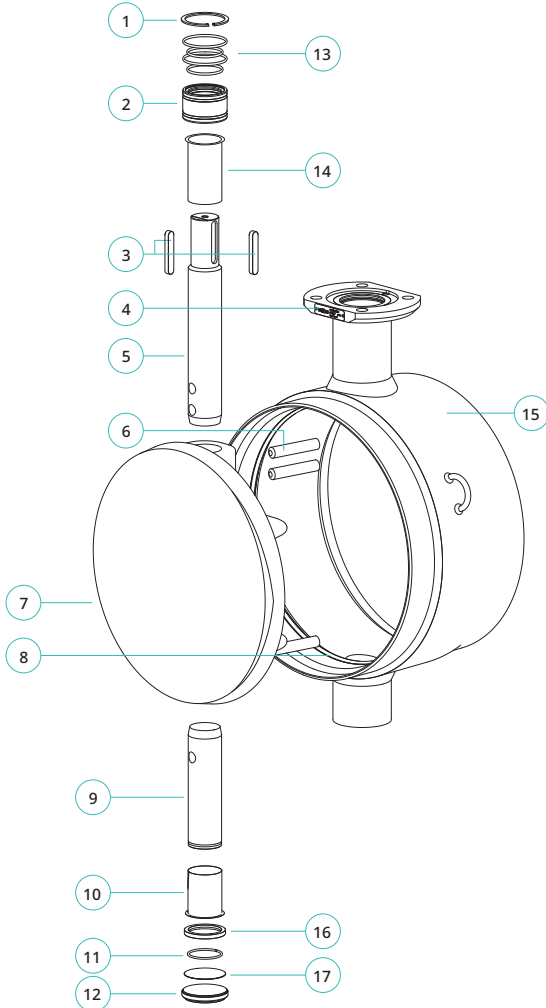

1	Retaining ring	1 pc
2	O-ring sleeve	1 pc
3	Key	2 pcs
4	Identification plate	1 pc
5	Upper stem	1 pc
6	Cylindrical pin	3 pcs
7	Disc	1 pc
8	Disc seal	1 pc
9	Lower stem	1 pc
10	Lower stem bearing	1 pc
11	Safety ring	1 pc
12	Lower stem washer	1 pc
13	O-ring	4 pcs
14	Upper stem bearing	1 pc
15	Valve body	1 pc
16	Positioner plate	1 pc
17	Sliding plate	1 pc

7.2 Parts list for BFC/BRC models

Valves made before 6/2020 have only one key.

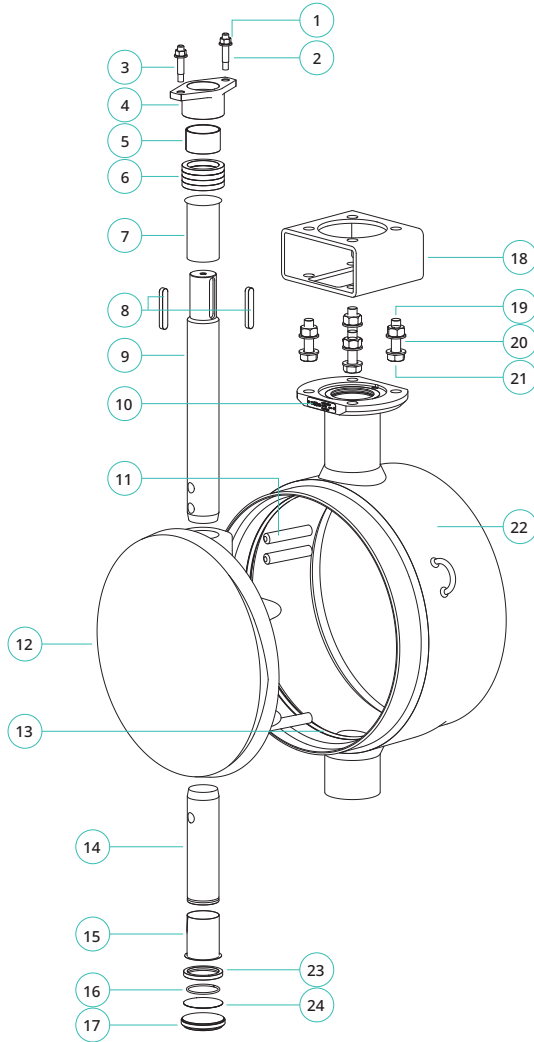

1	Hexagonal nut	2 pcs
2	Washer	2 pcs
3	Stud	2 pcs
4	Clamping bush	1 pc
5	Sliding bearing	1 pc
6	Stem seal	4 pc
7	Upper stem bearing	1 pc
8	Key	2 pcs
9	Upper stem	1 pc
10	Identification plate	1 pc
11	Cylindrical pin	3 pcs
12	Disc	1 pc
13	Disc seal	1 pc
14	Lower stem	1 pc
15	Lower stem bearing	1 pc
16	Lock ring	1 pc
17	Lower stem washer	1 pc
18	Actuator base	1 pc
19	Hexagonal nut	4 pcs
20	Washer	4 pcs
21	Hexagonal bolt	4 pcs
22	Valve body	1 pc
23	Positioner plate	1 pc
24	Sliding plate	1 pc

7.3 Type code

Vexve's butterfly valves are type coded utilizing a maximum of eight (8) characters:

1.	B	Butterfly valve
2.	F	Full bore, DN 300–800
	R	Reduced bore, DN 900–1600
3.	C	Control
	S	Shut-off
4.	XXX	DN (nominal size in millimeters)
5.	W	with (butt) weld connections
	F	with flanges
6.	1	Trim class $\Delta p = 16$ bar (note! body PN 25)
	2	Trim class $\Delta p = 25$ bar (note! body PN 25)
7.	/GS	with weld connections according to GOST (note! when not mentioned with weld connections according to EN (DIN))
8.	/E	Special equipment (note! Typically valve equipped with electric actuator; BFC/BRC-models also with manual gear).

Example: BFS600W1/GS/E

Full bore, shut-off type, DN 600 butterfly valve with GOST weld connections and electric actuator.

1.	2.	3.	4.	5.	6.		7.		8.
B	F	S	600	W	1	/	GS	/	E

Example: DN 400 Butterfly valve models

BFS400W1		BFS400W1/E	BFS400F1	BFS400F1/E
BFS400W2		BFS400W2/E	BFS400F2	BFS400F2/E
BFS400W1/GS	BFS400W1/GS/E			
BFS400W2/GS	BFS400W2/GS/E			
BFC400W1		BFC400W1/E	BFC400F1	BFC400F1/E
BFC400W2		BFC400W2/E	BFC400F2	BFC400F2/E
BFC400W1/GS	BFC400W1/GS/E			
BFC400W2/GS	BFC400W2/GS/E			

7.4 Coupling dimensions, BFS/BRS models

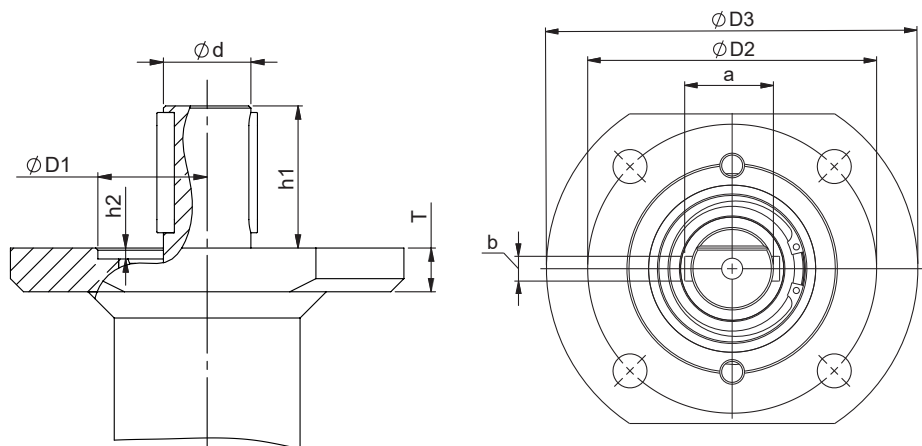

DN	d (mm)	D1 (mm)	D2 (mm)	D3 (mm)	h1 (mm)	h2 (mm)	a (mm)	b (mm)	Parallel Key DIN6885	T (mm)	bolts	Flange ISO5211
300	35	100	140	180	65	5	38	10	2 x A 10x8x56	20	4xM16	F14
350	35	100	140	180	65	5	38	10	2 x A 10x8x56	20	4xM16	F14
400	40	100	140	180	65	5	43	12	2 x A 12x8x55	20	4xM16	F14
450	50	130	165	210	80	5	53,5	14	2 x A 14x9x70	20	4xM20	F16
500	50	130	165	210	80	5	53,5	14	2 x A 14x9x70	20	4xM20	F16
600	60	200	254	300	110	7	64	18	2 x A 18x11x100	25	8xM16	F25
700	70	200	254	300	110	7	74,5	20	2 x A 20x12x110	25	8xM16	F25
750	90	230	298	350	110	6	95	25	2 x A 25x14x110	40	8xM20	F30
800	90	230	298	350	110	6	95	25	2 x A 25x14x110	40	8xM20	F30
900	100	260	356	415	180	6	106	28	2 x A 28x16x160	40	8xM30	F35
1000	120	260	356	415	180	6	127	32	2 x A 32x18x160	40	8xM30	F35
1200	120	260	356	415	180	6	127	32	2 x A 32x18x160	40	8xM30	F35
1400	140	325	406	475	220	9	148	36	2 x A 36x20x200	38	8xM36	F40
1600	200	372	483	560	250	9	210	45	2 x A 45x25x220	55	12xM36	F48

Note: Valves made before 6/2020 have only one key.

7.5 Coupling dimensions, BFC/BRC models

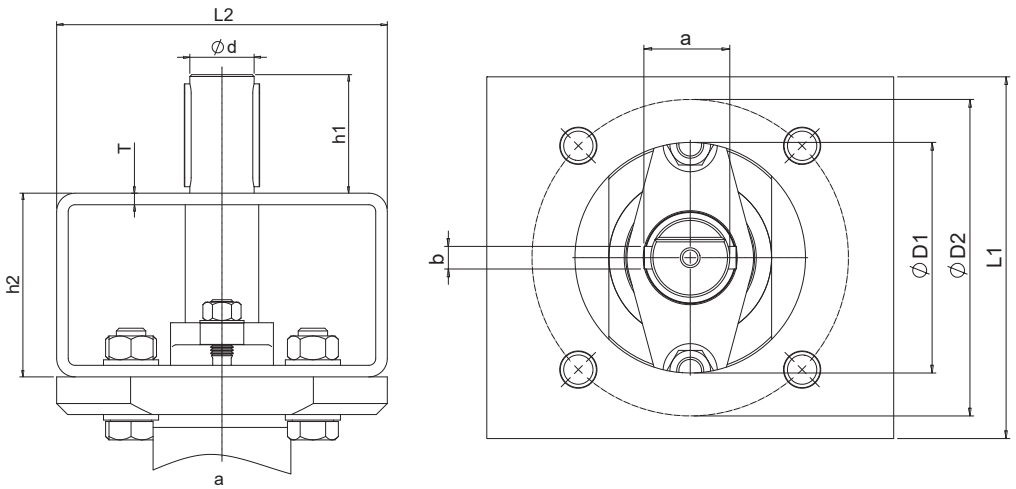

DN	d (mm)	D1 (mm)	D2 (mm)	L1 (mm)	L2 (mm)	h1 (mm)	h2 (mm)	T (mm)	a (mm)	b (mm)	Parallel Key DIN6885	bolts	Flange ISO5211
300	35	100	140	160	180	65	100	6,3	38	10	2 x A 10x8x56	4xM16	F14
350	35	100	140	160	180	65	100	6,3	38	10	2 x A 10x8x56	4xM16	F14
400	40	100	140	160	180	65	100	6,3	43	12	2 x A 12x8x55	4xM16	F14
450	50	130	165	180	200	80	100	8	53,5	14	2 x A 14x9x70	4xM20	F16
500	50	130	165	180	200	80	100	8	53,5	14	2 x A 14x9x70	4xM20	F16
600	60	200	254	270	300	110	100	8	64	18	2 x A 18x11x100	8xM16	F25
700	70	200	254	270	300	110	100	8	74,5	20	2 x A 20x12x110	8xM16	F25
750	90	230	298	350	400	130	120	10	95	25	2 x A 25x14x110	8xM20	F30
800	90	230	298	350	400	130	120	10	95	25	2 x A 25x14x110	8xM20	F30
900	100	260	356	400	450	180	150	12,5	106	28	2 x A 28x16x160	8xM30	F35
1000	120	260	356	400	450	180	150	12,5	127	32	2 x A 32x18x160	8xM30	F35
1200	120	260	356	400	450	180	150	12,5	127	32	2 x A 32x18x160	8xM30	F35

Note: Valves made before 6/2020 have only one key.



Vexve Oy

Pajakatu 11
38200 Sasstamala
Finland

Riihenkalliontie 10
23800 Laitila
Finland

Tel. +358 10 734 0800
vexve.customer@vexve.com

