

T300 - Maximum process volume capacity
500 L per cycle.



Our patented process is designed to **shred and sterilize** infectious waste by saturated steam. Shredding and sterilization are achieved in one fully **enclosed and automated, stainless steel, system with no intermediate waste handling.**



The contaminated waste is loaded into the upper chamber where a heavy-duty shredder reduces the waste into small pieces. Using gravity, the processed material drops into the lower treatment chamber.



After shredding, waste and all the inner parts of the machine are steam heated to 138°C (280 F) and pressurized to 3,5 bar (51 psi).



Sterilization is achieved by maintaining a temperature of 138°C (280 F) at the core of the waste for 10 minutes.



Waste are both sterilized (Microbial inactivation = 10^8 reduction of Geobacillus Stearotherophilus spores), volume-reduced by up to 80 % and weight-reduced by up to 40 % depending on the nature of the waste.



The 30 minutes duration of an average cycle process is fully automated and totally monitored. A computerized control system scans the process and automatically prints and records on a memory card a batch report at the end of each cycle with the essential sterilizing parameters for accurate record keeping.

Approved by the Higher Council of Public Health of France under the direction of the Ministry of Health and the Ministry of the Environment.

ASME CE LNE



Management System
ISO 9001:2015
ISO 14001:2015
www.tuv.com
© TÜV Rheinland



T300 - Maximum process volume capacity
500 L per cycle.



Technical specifications

General Characteristics

Dimensions (L x l x H)	270x210x330 Cm
Dimensions (L x W x H)	9,8x6,8x10,83 Ft
Total volume	1111 L
Shipping weight	2000 Kg
Max weight when filled with water for a special hydraulic test	3111 Kg
Stress	2 Kg/cm ²
Steam pressure	8 Bar
Max steam flow	170 Kg/h
Compressed air	6 Bar
Electricity 380 V / 3-Phase	14 kW

Operating Characteristics

Treatment temperature	130 - 177 °C
Average cycle time	30 Minutes
Max loading volume capacity	500 L
Average process volume capacity	350 L
Average waste density	100 - 150 Kg/m ³
Average process weight capacity	35-53 Kg/cycle 77-117 Lb/cycle
Sterilization: Reduction of Geobacillus Stearothermophilus spores	10 ⁸
Waste volume reduction	80%
Max waste weight reduction (depending on the nature of the waste)	40%

Consumption / cycle

Steam	15 Kg
Electricity	1,7 kWh
Water	25 L

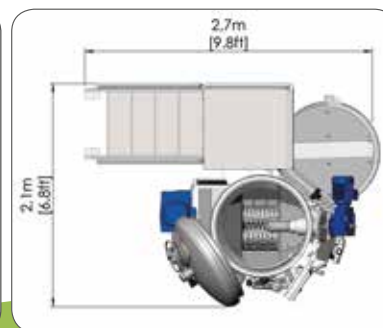
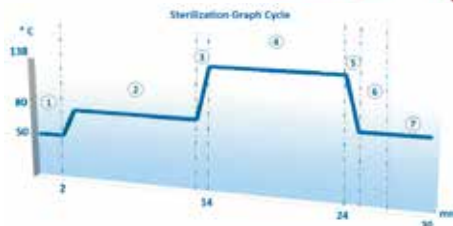

28 rue Sébastopol
59100 ROUBAIX - FRANCE

Tél. +333 20 70 98 65

contact@ecodas.com
www.ecodas.com

