

Entris® II Advanced Line



Benefits

- Simplifies balance leveling—with built-in real-time level support
- Increases reliability of weighing results—using integrated protection systems
- Controlled access to balance settings—with user management
- Gapless documentation—thanks to CalAuditTrail

Product Information

No matter what you are weighing, the new Entris® II balance is always the right choice. Offering unrivalled value and backed by almost 150 years of German engineering expertise, the Entris® II comes in two product lines, so you can find the balance that meets your specific weighing needs.

Our Entris® II Advanced line gives additional value to the Entris II portfolio, with over 38 models offering benefits such as real-time level support, integrated protection systems, Cal Audit Trail, a graphic touch display and 13 built-in application programs.

Technical Specifications

General Technical Data

Ambient Conditions		Value
Installation site	For indoor use only, max. height above sea level	3000 m
Temperature	Environment (metrological data)*	+10 – +30° C
	Environment	+5 – +40° C
	Storage and transport	-10 – +60° C
Relative humidity**	At temperatures up to 31° C, non-condensing, then linear decrease from max. 80% at 31° C to max. 50% at 40° C	15 – 80%
No heat from heating systems or direct sunlight		
No electromagnetic fields		
Power Supply Device		Value
Input voltage		15 V _{DC} (±10%)
Power consumption, max		4 W
Only by Sartorius power supply unit YEPS01-15V0W with interchangeable country-specific plug-in AC adaptors		
Power Supply Unit		Value
Type: Sartorius power supply unit YEPS01-15V0W		
Primary	Voltage	100 – 240 V _{AC} (±10%)
	Frequency	50 – 60 Hz
	Current consumption, maximum	0.2 A
Secondary	Voltage	15 V _{DC} (±5%)
	Current, maximum	0.53 A
Short-circuit protection		Electronic
Protection class according to IEC 60950-1		II
Pollution level according to IEC 61010-1		2
Overvoltage category according to IEC 60664-1		II
Other data: See label on the power supply unit		
Electromagnetic Compatibility		
Interference resistance: Suitable for use in industrial areas		
Transient emissions	Class B Suitable for use in residential areas and areas that are connected to a low voltage network that also supplies residential buildings	
Materials		
Housing	Polybutylene terephthalate (PBT)	
Control module	Glass	
Draft shield	Glass polybutylene terephthalate (PBT)	
Weighing pan	Stainless steel	
Warm-up Time		Value
Device, approx		2 h

* For conformity-assessed (verified) balances in accordance with EU requirements, refer to the information on the balance.

** For conformity-assessed (verified) balances in accordance with EU requirements, the legal regulations apply.

Interfaces

Specifications of the RS232 Interface

Type of interface	Serial interface
Interface operation	Full duplex
Level	RS232
Connection	D-sub connector, 9-pin
Maximum cable length	10 m

Pin assignment

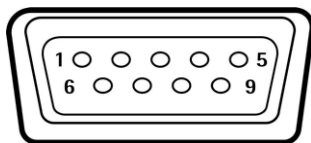

Pin 1: Not assigned
Pin 2: Data output (TxD)
Pin 3: Data input (Rx/D)
Pin 4: Not assigned
Pin 5: Internal ground
Pin 6: Not assigned
Pin 7: Clear to Send (CTS)
Pin 8: Request to Send (RTS)
Pin 9: Universal key

Specifications for the USB-C Interface

Communication	USB UTL
Connectable devices	Sartorius printers, Sartorius second display, FTDI cable or USB memory stick

Specifications for the PC-USB Interface

Communication	USB Device
Connectable devices	PC

Calibration

Internal calibration isoCAL (models with marking i-1x)

External calibration

Selectable Weight Units*

Gram, kilogram, carat, pound, ounce, troy ounce, Hong Kong tael, Singapore tael, Taiwan tael, grain, pennyweights, milligram, parts per pound, China tael, mommes, Austrian carat, tola, baht, mesghal and Newton

Display

Intuitive graphic touch technology

Built-in Applications

- Weighing | Dosing
 - Counting
 - Percentage weighing
 - Mixing | Net total
 - Components | Totalizing
 - Animal weighing
 - Calculation | Free factor
 - Density determination
 - Underfloor weighing feature for bigger samples
 - Statistics
 - Peakhold
 - Checkweighing
 - Mass unit conversion
 - Pipette smart test
-

Languages

English, German, France, Italian, Spanish, Portuguese, Russian, Polish, Chinese, Japanese, Korean, Turkish, Hungarian

Protection

- Chemical resistant housing parts
 - Glass parts of the draft shield are coated to reduce electrostatic influences
 - Display foil (available as accessory)
 - Dust cover for balances (also available as accessory)
-

Anti-theft Lock

Kensington lock and lockdown capability for cable or chain

* The availability of units depends on national legislation and is therefore country-specific.

Models with Internal Adjustment Feature

Model BCA	Unit	324i-1x ¹	224i-1x ¹	124i-1x ¹	64i-1x ¹	1203i-1x ¹	623i-1x ¹	423i-1x ¹	323i-1x ¹
Readability Scale interval (d)	mg	0.1	0.1	0.1	0.1	1	1	1	1
Maximum capacity (Max)	g	320	220	120	60	1,200	620	420	320
Weighing system		EMC	EMC	EMC	EMC	EMC	EMC	EMC	EMC
Repeatability									
At 5% load, typical value	± mg	0.08	0.08	0.08	0.08	0.5	0.5	0.5	0.5
At approx. maximum load, typical value	± mg	0.1	0.1	0.1	0.1	1	1	1	1
Linearity deviation									
Limits	± mg	0.3	0.2	0.2	0.2	2	2	2	2
Typical value	± mg	0.06	0.06	0.06	0.06	0.6	0.6	0.6	0.6
Sensitivity drift between +10° C and +30° C	± ppm/K	1	1	1	1	1.5	2	2	2
Tare maximum capacity (subtractive)		<100% of maximum capacity							
isoCAL (only for i-1x models):									
Temperature change	K	1.5	1.5	1.5	1.5	1.5	2	2	2
Time interval	h	4	4	4	4	4	6	6	6
For models with approval:									
Accuracy class		I	I	I	I	I	II	II	II
Type		BC-AA	BC-AB	BC-AB	BC-AB	BC-AC	BC-AD	BC-AD	BC-AD
Verification scale interval (e)	mg	1	1	1	1	10	10	10	10
Minimum load (Min)	mg	10	10	10	10	100	20	20	20
Minimum initial weighing according to USP (United States Pharmacopeia), Chap. 41									
Optimum minimum initial weighing	g	0.082	0.082	0.082	0.082	0.82	0.82	0.82	0.82
Typical minimum initial weighing	g	0.16	0.16	0.16	0.16	1	1	1	1
Typical measurement time	s	≤2.0	≤2.0	≤2.0	≤2.0	≤1.5	≤1.5	≤1.5	≤1.5
Typical stabilization time	s	≤1.5	≤1.5	≤1.5	≤1.5	≤1.0	≤1.0	≤1.0	≤1.0
Recommended calibration weight									
External calibrated test weight	g	200	200	100	50	1,000	500	200	200
Accuracy class in accordance with OIML R111-1		E2	E2	E2	E2	E2	F1	F1	F1
Weighing pan size	mm	Ø 90	Ø 90	Ø 90	Ø 90	Ø 120	Ø 120	Ø 120	Ø 120
Weighing chamber height*	mm	240	240	240	240	240	240	240	240
Net weight, approx.	kg	6.20	6.20	6.20	6.20	6.30	6.30	6.30	6.30
Gross weight, approx.	kg	8.00	8.00	8.00	8.00	8.10	8.10	8.10	8.10

* upper edge of the weighing pan to the lower edge of the upper draft shield panel

¹ Country-specific marking in model:

x = S: Standard balances without country-specific additions

x = SAR: Standard balances with country-specific additions for Argentina

x = SJP: Standard balances with country-specific additions for Japan

x = SKR: Standard balances with country-specific additions for South Korea

x = CCN: Balances with approval for China

x = CEU: Conformity-assessed balances with EU type examination certificate without country-specific additions

x = CFR: Conformity-assessed balances with EU type examination certificate only for France

x = OBR: Balances with approval for Brazil

x = OIN: Balances with approval for India

x = OJP: Balances with approval for Japan

x = ORU: Balances with approval for Russia

223i-1x ¹	6202i-1x ¹	4202i-1x ¹	3202i-1x ¹	2202i-1x ¹	1202i-1x ¹	822i-1x ¹	12201i-1x ¹	10201i-1x ¹	8201i-1x ¹	5201i-1x ¹	2201i-1x ¹
1	10	10	10	10	10	10	100	100	100	100	100
220	6,200	4,200	3,200	2,200	1,200	820	12,200	10,200	8,200	5,200	2,200
EMC	EMC	EMC	EMC	EMC	EMC	EMC	EMC	EMC	EMC	EMC	EMC
0.5	5	5	5	5	5	5	50	50	50	50	50
1	10	10	10	10	10	10	100	100	100	50	50
2	20	20	20	20	20	20	100	100	100	100	100
0.6	6	6	6	6	6	6	60	60	60	60	60
2	2	2	2	2	2	2	4	4	4	2	2
<100% of maximum capacity											
2	2	2	2	2	2	2	2	2	2	2	2
6	6	6	6	6	6	6	6	6	6	6	6
II	II	II	II	II	II	II	II	II	II	II	II
BC-AD	BC-AE	BC-AE	BC-AE	BC-AE	BC-AE	BC-AE	BC-AG	BC-AG	BC-AG	BC-AE	BC-AE
10	100	100	100	100	100	100	1,000	1,000	1,000	100	100
20	500	500	500	500	500	500	5,000	5,000	5,000	5,000	5,000
0.82	8.2	8.2	8.2	8.2	8.2	8.2	82	82	82	82	82
1	10	10	10	10	10	10	100	100	100	100	100
≤1.5	≤1.0	≤1.0	≤1.0	≤1.0	≤1.0	≤1.0	≤1.0	≤1.0	≤1.0	≤1.0	≤1.0
≤1.0	≤0.9	≤0.9	≤0.9	≤0.9	≤0.9	≤0.9	≤0.9	≤0.9	≤0.9	≤0.9	≤0.9
200	5,000	2,000	2,000	2,000	1,000	500	10,000	10,000	5,000	5,000	2,000
F1	F1	F1	F1	F1	F1	F2	F2	F2	F2	F2	F2
Ø 120	182 x 182	182 x 182	182 x 182	182 x 182	182 x 182	182 x 182	182 x 182	182 x 182	182 x 182	182 x 182	182 x 182
240	-	-	-	-	-	-	-	-	-	-	-
6.30	6.20	6.20	6.20	6.20	6.20	6.20	6.20	6.20	6.20	6.20	6.20
8.10	7.00	7.00	7.00	7.00	7.00	7.00	7.00	7.00	7.00	7.00	7.00

Models without Internal Adjustment Feature, without Approval

Model BCA	Unit	224-1x ¹	124-1x ¹	64-1x ¹	623-1x ¹	423-1x ¹	323-1x ¹	223-1x ¹
Readability Scale interval (d)	mg	0.1	0.1	0.1	1	1	1	1
Maximum capacity (Max)	g	220	120	60	620	420	320	220
Weighing system		EMC	EMC	EMC	EMC	EMC	EMC	EMC
Repeatability								
At 5% load, typical value	± mg	0.08	0.08	0.08	0.5	0.5	0.5	0.5
At approx. maximum load, typical value	± mg	0.1	0.1	0.1	1	1	1	1
Linearity deviation								
Limits	± mg	0.2	0.2	0.2	2	2	2	2
Typical value	± mg	0.06	0.06	0.06	0.6	0.6	0.6	0.6
Sensitivity drift between +10° C and +30° C	± ppm/K	1	1	1	2	2	2	2
Tare maximum capacity (subtractive)		<100% of maximum capacity						
isoCAL (only for i-1x models):								
Temperature change	K	-	-	-	-	-	-	-
Time interval	h	-	-	-	-	-	-	-
For models with approval:								
Accuracy class		-	-	-	-	-	-	-
Type		-	-	-	-	-	-	-
Verification scale interval (e)	mg	-	-	-	-	-	-	-
Minimum load (Min)	mg	-	-	-	-	-	-	-
Minimum initial weighing according to USP (United States Pharmacopeia), Chap. 41								
Optimum minimum initial weighing	g	0.082	0.082	0.082	0.82	0.82	0.82	0.82
Typical minimum initial weighing	g	0.16	0.16	0.16	1	1	1	1
Typical measurement time	s	≤2.0	≤2.0	≤2.0	≤1.5	≤1.5	≤1.5	≤1.5
Typical stabilization time	s	≤1.5	≤1.5	≤1.5	≤1.0	≤1.0	≤1.0	≤1.0
Recommended calibration weight								
External calibrated test weight	g	200	100	50	500	200	200	200
Accuracy class in accordance with OIML R111-1		E2	E2	E2	F1	F1	F1	F1
Weighing pan size	mm	Ø 90	Ø 90	Ø 90	Ø 120	Ø 120	Ø 120	Ø 120
Weighing chamber height*	mm	240	240	240	240	240	240	240
Net weight, approx.	kg	5.90	5.90	5.90	5.90	5.90	5.90	5.90
Gross weight, approx.	kg	7.70	7.70	7.70	7.70	7.70	7.70	7.70

* upper edge of the weighing pan to the lower edge of the upper draft shield panel

¹ Country-specific marking in model:

x = S: Standard balances without country-specific additions

x = SAR: Standard balances with country-specific additions for Argentina

x = SJP: Standard balances with country-specific additions for Japan

x = SKR: Standard balances with country-specific additions for South Korea

6202-1x ¹	4202-1x ¹	3202-1x ¹	2202-1x ¹	1202-1x ¹	822-1x ¹	12201-1x ¹	10201-1x ¹	8201-1x ¹	5201-1x ¹	2201-1x ¹
10	10	10	10	10	10	100	100	100	100	100
6,200	4,200	3,200	2,200	1,200	820	12,200	10,200	8,200	5,200	2,200
EMC	EMC	EMC	Strain gauge	Strain gauge	Strain gauge	EMC	EMC	Strain gauge	Strain gauge	Strain gauge
5	5	5	5	5	5	50	50	50	50	50
10	10	10	10	10	10	100	100	100	100	100
20	20	20	20	20	20	100	100	300	300	300
6	6	6	6	6	6	60	60	100	100	100
2	2	2	3.5	3.5	3.5	4	4	7	7	7
<100% of maximum capacity										
-	-	-	-	-	-	-	-	-	-	-
-	-	-	-	-	-	-	-	-	-	-
-	-	-	-	-	-	-	-	-	-	-
-	-	-	-	-	-	-	-	-	-	-
-	-	-	-	-	-	-	-	-	-	-
-	-	-	-	-	-	-	-	-	-	-
8.2	8.2	8.2	8.2	8.2	8.2	82	82	82	82	82
10	10	10	10	10	10	100	100	100	100	100
≤1.0	≤1.0	≤1.0	≤1.0	≤1.0	≤1.0	≤1.0	≤1.0	≤1.0	≤1.0	≤1.0
≤0.9	≤0.9	≤0.9	≤0.9	≤0.9	≤0.9	≤0.9	≤0.9	≤0.9	≤0.9	≤0.9
5,000	2,000	2,000	2,000	1,000	500	10,000	10,000	5,000	5,000	2,000
F1	F1	F1	F1	F1	F2	F2	F2	F2	F2	F2
182 x 182	182 x 182	182 x 182	182 x 182	182 x 182	182 x 182	182 x 182	182 x 182	182 x 182	182 x 182	182 x 182
-	-	-	-	-	-	-	-	-	-	-
4.60	4.60	4.60	4.30	4.30	4.30	4.60	4.60	4.30	4.30	4.30
5.10	5.10	5.10	5.10	5.10	5.10	5.10	5.10	5.10	5.10	5.10

Technical Drawings

Models with a readability of 0.1 mg
All dimensions are given in millimeters

Models with a readability of 1 mg
All dimensions are given in millimeters

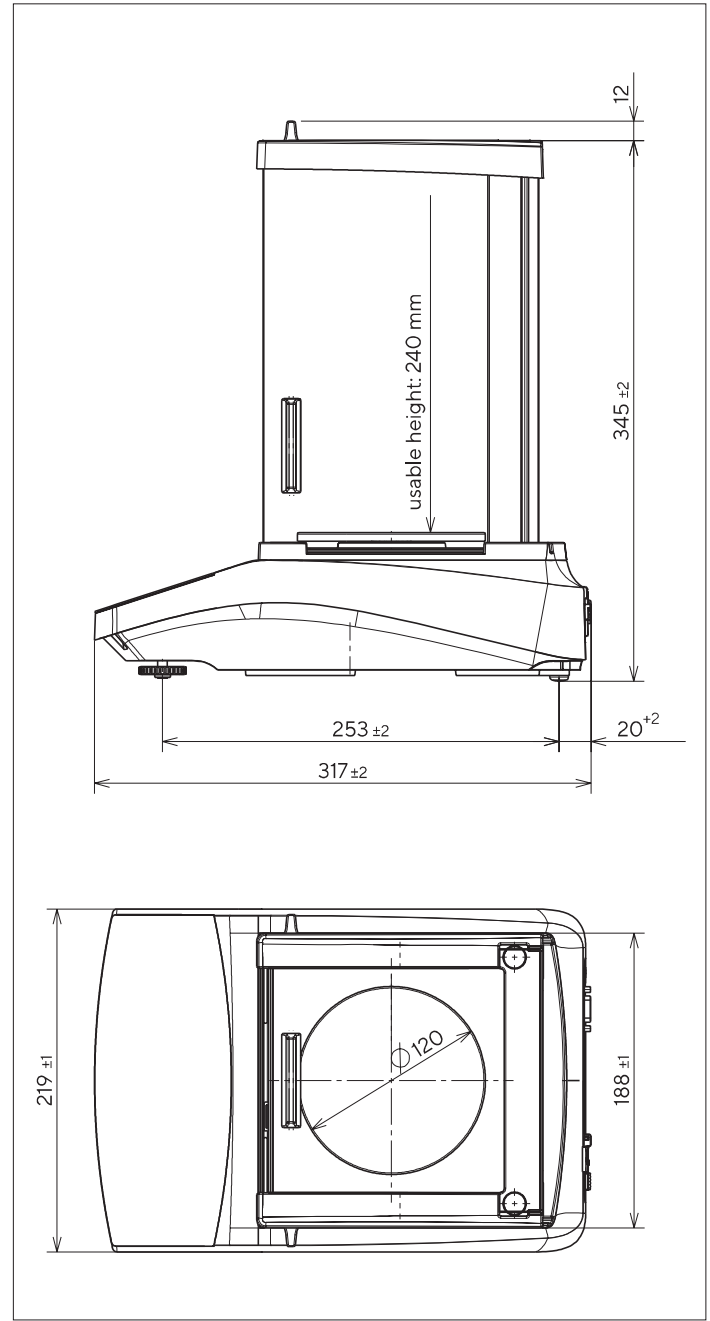
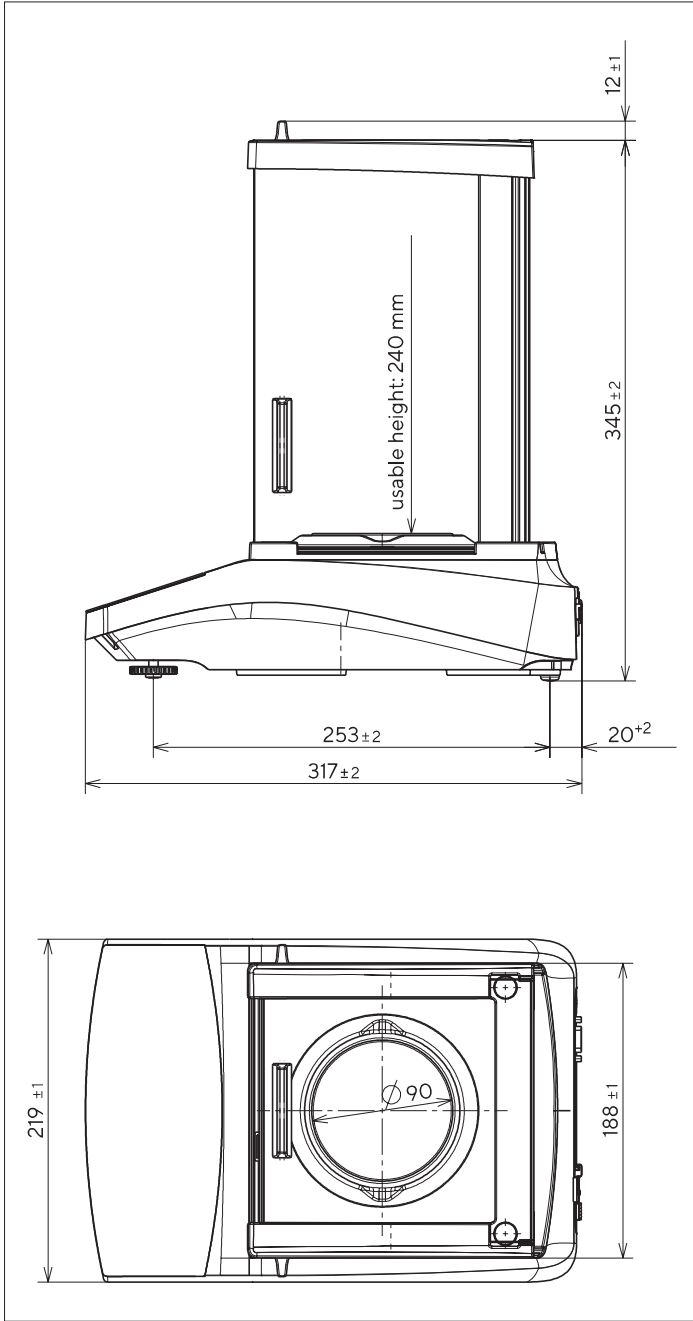

Models with a readability of ≥ 10 mg
All dimensions are given in millimeters

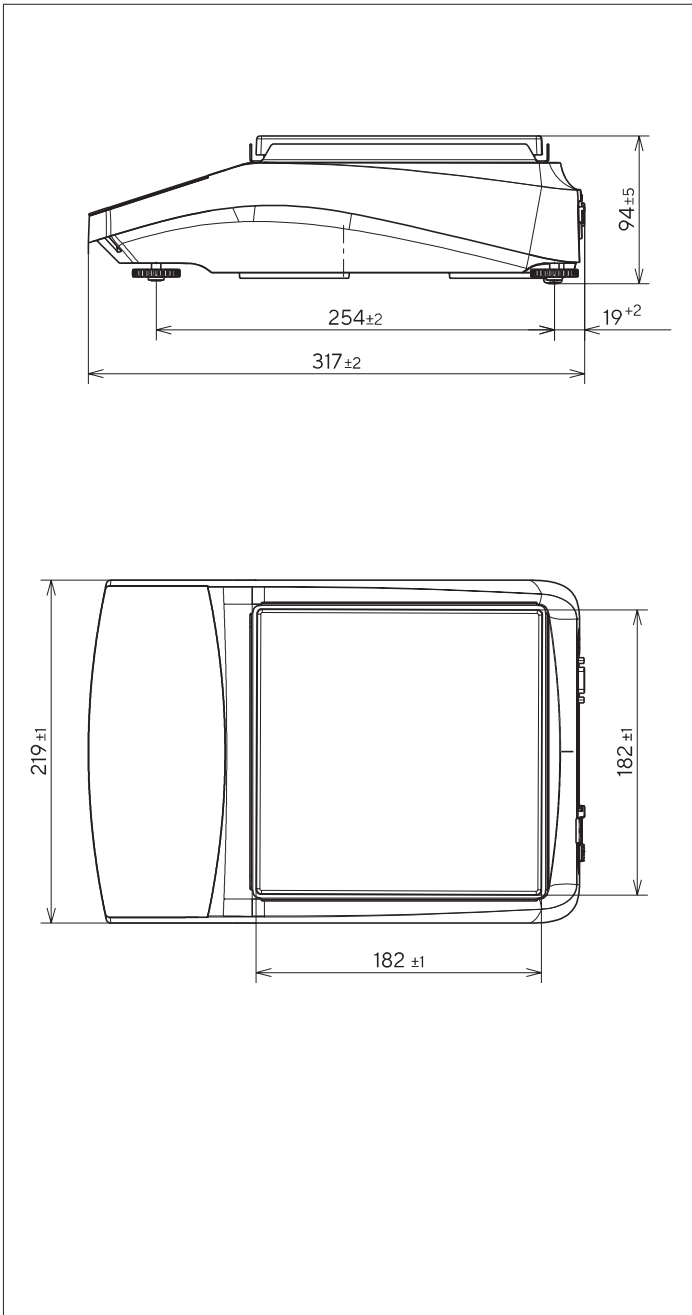

Accessories

These tables contain an excerpt of the accessories that can be ordered. For information on other products, contact Sartorius.

Balance Accessories

Item	Quantity	Order number
Display protection film (set of 5)	1	YDC10
Dust cover for balances with an analytical draft shield	1	6960BC01
Dust cover for balances with rectangular weighing pan	1	YDC30
In-use cover (set of 5)	1	YIC01
Density determination set for solids and liquids for balances with a readability of 0.1 mg 1 mg	1	YDK03
"Kensington Lock" anti-theft device	1	YKL01
Pedal button foot switch	1	YFS03
Second display remote display	1	YSD01
Below-balance weighing (not for models in legal metrology)		
Hook M5	1	69EA0039
Weighing table		
Made from wood with natural stone	1	YWT09
Made from natural stone, with vibration dampening	1	YWT03
Wall console made from natural stone	1	YWT04
Converter cable 5 V _{DC} > 15 V _{DC}	1	YCC-5V-15V

Printer and Accessories for Data Communication

Item	Quantity	Order number
Thermal printer (USB-B)	1	YDP40
Thermal transfer printer (USB-B, RS232)	1	YDP30
Dot matrix printer (RS232)*	1	YDP20-OCE
Data cable USB-C > USB-B (>YDP30, YDP40)	1.5 m	YCC-USB-C-B
Data cable USB-C > USB-A (>PC)	1.5 m	YCC-USB-C-A
Data cable RS232 (9-pin) > USB-A (>PC)	1.5 m	YCC-D09M-USB-A
Data cable RS232 (9-pin) male > RS232 (9-pin) male (> YDP30)	1.5 m	YCC-D09MM
Data cable RS232 (9-pin) male > RS232 (9-pin) female (>YDP20-OCE, YSD01)	1.5 m	YCC-D09MF
Y-adaptor RS232 (9-pin) male > 2x RS232 (9-pin) female	0.15 m	YCC-D09M-2D09F

*additional power supply e.g. YEPS01-PS4 or YEPS01-PS5 is required

External Calibration and Adjustment Weights

BCA model	Weight	Accuracy class	Order number
324 224	200 g	E2	YCW522-AC-02
124	100 g	E2	YCW512-AC-02
64	50 g	E2	YCW452-AC-02
1203	1,000 g	E2	YCW612-AC-02
623	500 g	F1	YCW553-AC-02
423 323 223	200 g	F1	YCW523-AC-02
6202	5,000 g	F1	YCW653-AC-02
4202 3202 2202	2,000 g	F1	YCW623-AC-02
1202	1,000 g	F1	YCW613-AC-02
822	500 g	F2	YCW554-AC-02
12201 10201	10,000 g	F2	YCW714-AC-02
8201 5201	5,000 g	F2	YCW654-AC-02
2201	2,000 g	F2	YCW624-AC-02

Sales and Service Contacts

For further contacts, visit
www.sartorius.com

Germany

Sartorius Lab Instruments
GmbH & Co. KG
Otto-Brenner-Strasse 20
37079 Goettingen
Phone +49 551 308 0

USA

Sartorius Corporation
565 Johnson Avenue
Bohemia, NY 11716
Phone +1 631 254 4249
Toll-free +1 800 635 2906