

Ultrimis NEO

Ultrasonic water meter

DN15-DN50



Ultrimis, a state-of-the-art ultrasonic water meter with the latest patented design features the W-Sonic Technology, a unique metering method. The W-Sonic Technology enables meter readings in the R1600 range with the starting flow already from 0.75 l/h.

The water meter is designed and manufactured to the highest quality standards. The water meter is rated at IP68 and with a high resistance to hydraulic shock and magnetic interference. The measurement chamber is designed to provide the water meter with insensitivity to hydraulic shock. The ultrasonic measurement technology of the water meter is completely impervious to interference from magnetic fields.

APPLICATION

Water supply systems with the maximum cold water temperature of 50°C and the maximum hot water temperature of 70°C, requiring reliable water consumption metering and reliable data communication methods, including remote meter reading over NFC, WM-Bus or LoRaWAN. The water meter can be installed in any orientation and does not require upstream and downstream sections of straight piping.

Ultrimis NEO



Advantages

Provides savings

- High-precision measurement **improves efficiency** of water use: the water meter can detect all leaks in the supply system
- **No moving** parts for a high resistance to fouling: cost-free inspection and maintenance
- No upstream or downstream **straight sections** of piping required
- **Compact size** for easy installation in confined spaces
- Robust design and **minimum electrical power demand** for a stable, long-term operation
- A wide **measurement range** with immunity to electrical conductivity of metered water (as required for electromagnetic water meter systems)
- Extremely **low pressure loss** (and low resistance to flow)

Convenient in operation

- Standard **IP68**-rated hermetically sealed body
- **No risk of physical wear** of the measurement chamber components during continuous operation, even at high flow rates
- MAP - **16 bar**
- Body material - **brass** or **composite**
- **Resistant** to strong **magnetic fields**
- Resistant to **hydraulic shock**
- Highly resistant to overload flow rate - Q_4

Measurement accuracy

- Optimized measurement range: up to **R1600** in every operating orientation (**H, V, and H/V**)
- Starting flow already from **0.75 l/h**
- **Stable** measurement system performance by insensitivity to fouling
- Back flow **measurement** enabled by a symmetrical structure and the applied measurement algorithms

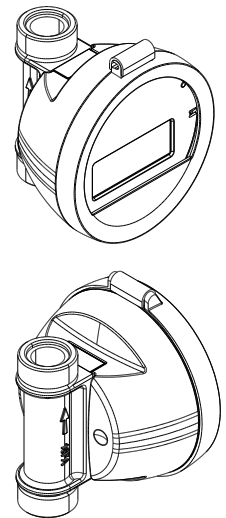

Environmentally friendly

- Extremely **low power usage** when in operation
- Very low lithium content: **Li < 1.8 g**
- Maximum design battery life of 16 years (depending on the configuration and environmental conditions)
- Low energy output at the water supply side (the unit pressure drop across the water meter is **0.17 bar** at DN40 for Q_3)
- A measurement range up to R1600 is also available for the water meter installation length **L = 80 mm**
- **Very low weight**: low costs of transport
- Low carbon footprint

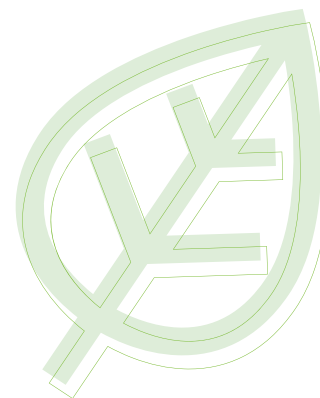

Innovative

The Ultrimis water meter features a unique measurement system: it emits an ultrasonic beam across the measurement chamber, which results in steady indications and errors in the whole measurement range. This is the W-Sonic Technology which includes distinctive characteristics:

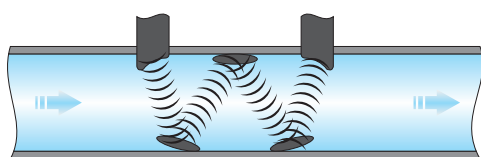

- With its unique ultrasonic beam pattern, the Ultrimis can be much more compact than other ultrasonic metering systems
- The full-bore design does not entrap any fouling or solids
- Insensitive to measurement bias from water contamination
- Sophisticated control algorithms of the ultrasonic beam system provide compensation for component ageing
- Requires no filters or check valves

Communication

- Water meter data reading over NFC (Near Field Communication)
- RF (radio-frequency) reading of indications compatible with WM-Bus and/or LoRaWAN
- RF indication reading for walk-by and drive-by reading systems and stationary reading systems without any reconfiguration required
- Secondary verification at any suitable location with the Testbox module and a dedicated application

NFC configuration

The Ultrimis water meters feature standard NFC data communication which enables configuration of the operating mode, reading of actual parameter values of the instrument and downloading the historical indications of statuses and errors (even at a low battery voltage or meter failure).

Developed specifically for the Ultrimis water meter, the data communication interface includes a dedicated SPIDAP application and the Testbox module. The data communication interface enables re-verification by secondary verification operators SPIDAP.

The data logger supported by NFC enables modification of the interval and range of data logging.

The data logging interval can be configured from 12 minutes to 45 days. One of the 10 predefined data acquisition sets can also be selected.

Depending on the data acquisition set selected, up to 800 unique records can be stored. The data acquired can drive histograms to evaluate whether the water meter has been specified correctly for its actual application.



Rf reading

The water meter has an integrated RF data communication module for easy and efficient remote data reading in walk-by, drive-by and stationary reading systems.

Wireless M-Bus + LoRaWAN

The Ultrimis LoRaWAN + WM-Bus water meter versions are intended for stationary reading systems. They facilitate default data communication over LoRaWAN with a long range and a low power consumption. If there is no LoRaWAN service, the water meter automatically switches over to WM-Bus communication. One of the following data communication methods can also be configured for permanent use:

- LoRaWAN only
- WM-Bus only
- Hybrid – LoRaWAN is default; if there is no LoRaWAN service, WM-Bus is automatically switched to.

The LoRaWAN communication is divided into two areas:

- Standard data communication, each with an RF data frame output every 7 hours and holding the data from the previous 14 hours
- Emergency data communication is triggered instantly when a predefined event emerges.

WMBUS/LoRaWAN/NFC communication allows you to receive the following data:

- Water meter indications (historical and at the time of reading)
- Reverse volume (at the time of the reading)
- Water temperature (at the time of the reading)
- Events/alarms (from a logged month of choice, the current month, and at the time of reading), including:
 - Reverse flow
 - Low flow
 - High flow
 - No water
 - Low battery
 - Tampering detected
 - Temperature limit violation
 - Zero flow

LoRaWAN network extension

Enhance your IoT network with our advanced **LoRaWAN® Relay**. Extend the reach of your Ultrimis NEO water meters for improved connectivity, even in challenging environments. Explore the potential of your IoT solutions with our dependable LoRaWAN® relay.

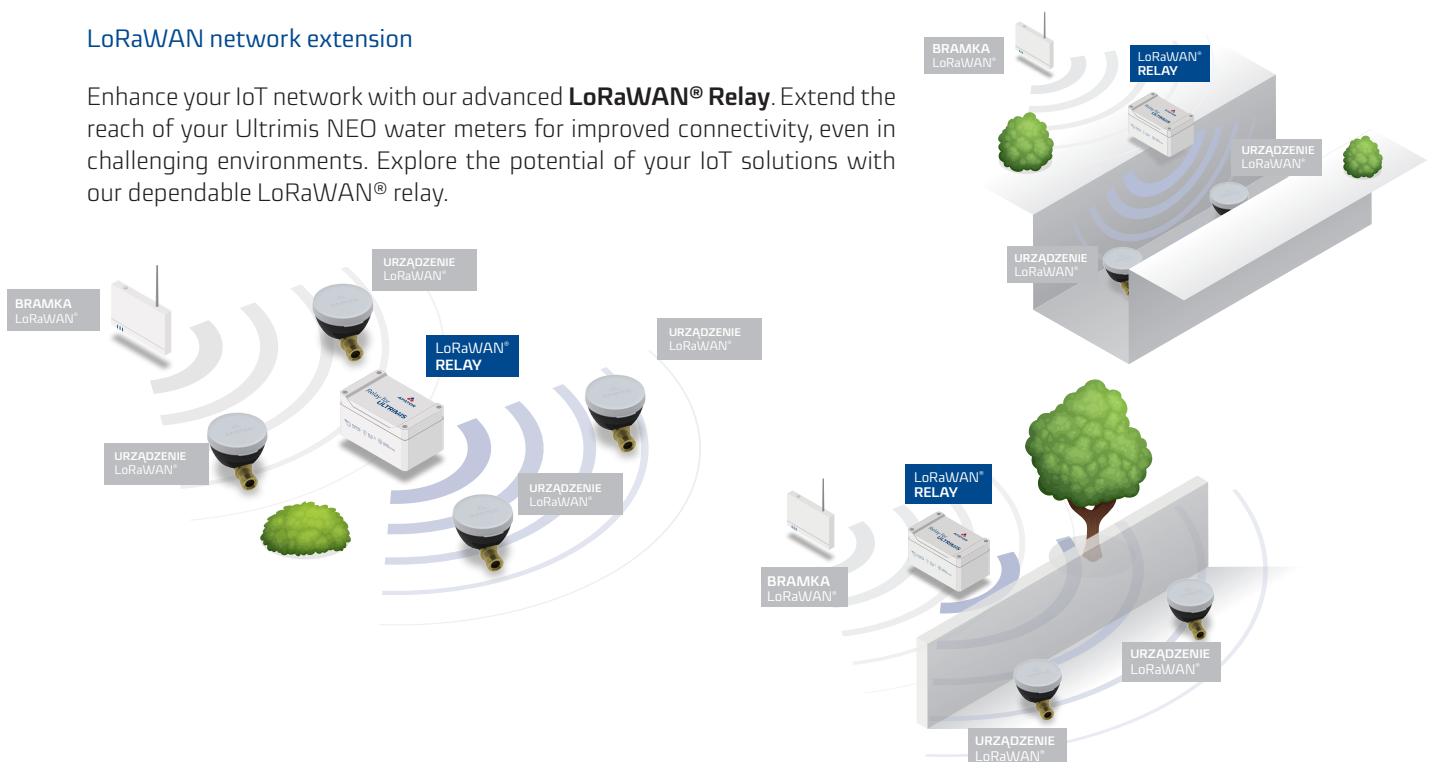

Lcd display functions

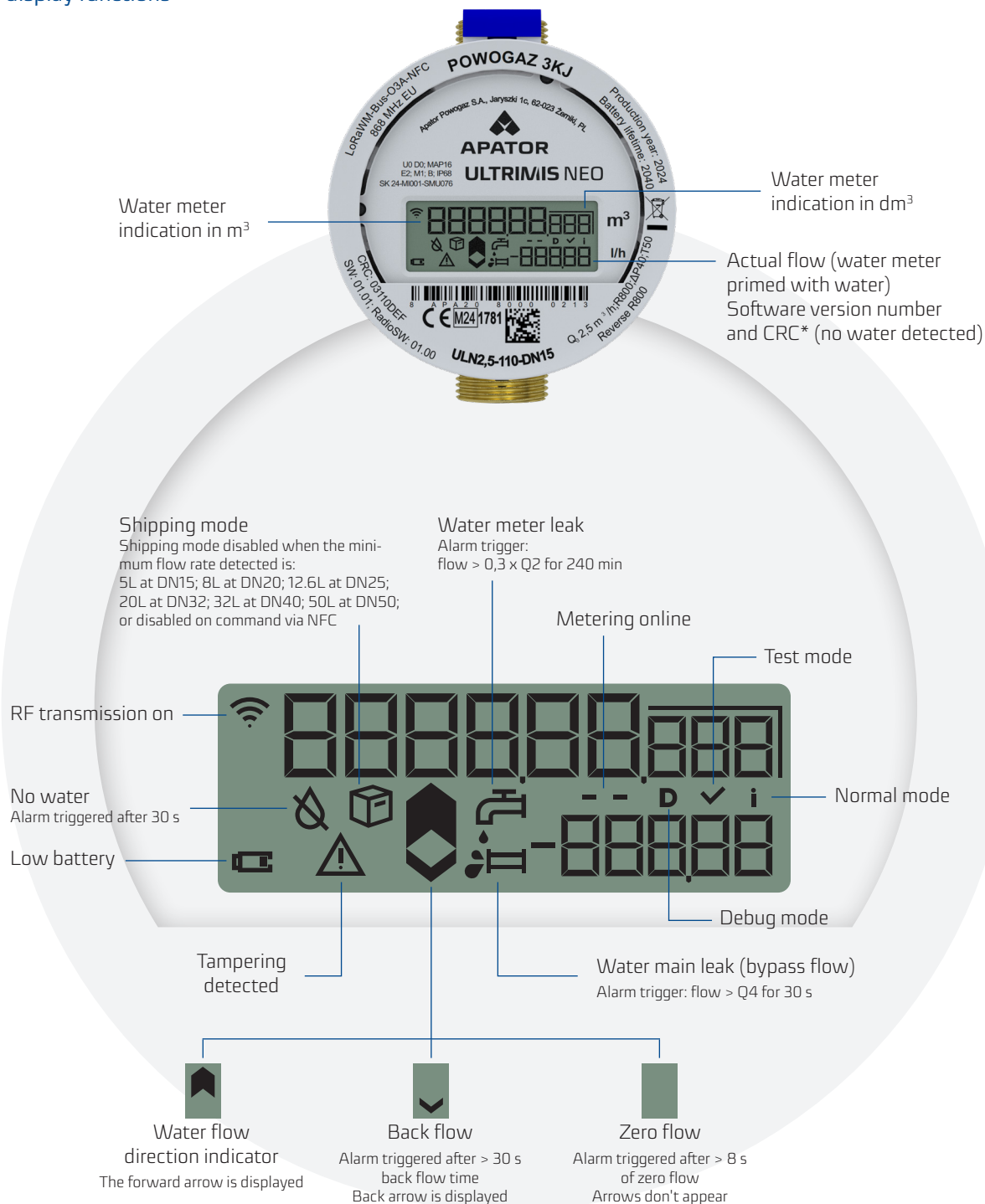

Events not indicated on the lcd

Overtemperature
Switchover
for T50: <2°C or >50°C
for T70: <2°C or >70°C

Table 1. Technical specifications

Specification			Ultrimis NEO									
			ULN 2.5		ULN 2.5-01		ULN 4		ULN 4-01		ULN6,3	ULN10
Nominal diameter	DN	mm	15		20		25		32	40	50	
Permanent flow rate	Q₃	m³/h	2.5		4		6.3		10	16	25	
Overload flow rate	Q₄	m³/h	3.125		5		7.875		12.5	20	31.25	
Transitional flow rate	Q ₂	dm ³ /h	16		25.6		40.32		64	102,4	160	
Minimum flow rate	Q ₁	dm ³ /h	10		16		25.2		40	64	100	
Measurement range	R	Q ₃ /Q ₁	250									
Transitional flow rate	Q ₂	dm ³ /h	10		16		25		40	64	100	
Minimum flow rate	Q ₁	dm ³ /h	6		10		16		25	40	62.5	
Measurement range	R	Q ₃ /Q ₁	400									
Transitional flow rate	Q ₂	dm ³ /h	-		-		-		-	-	-	80
Minimum flow rate	Q ₁	dm ³ /h	-		-		-		-	-	-	50
Measurement range	R	Q ₃ /Q ₁	500									
Transitional flow rate	Q ₂	dm ³ /h	5		8		13		20	32	-	
Minimum flow rate	Q ₁	dm ³ /h	3		5		8		13	20	-	
Measurement range	R	Q ₃ /Q ₁	800									
Starting flow for R250, R400, R800	-	dm ³ /h	0.75		1.2		1.89		3	4.8	12	
Range for R250, R400, R800	-	Q₂/Q₁	1.6									
Temperature class (EN and OIML)	-	°C	T30, T50, T70					T30, T50				
Flow profile sensitivity class (EN)	-	-	U0, D0									
Counter indication range	-	m ³	999999									
Scale interval value	-	m ³	0.001									
Maximum permissible error in the range of Q ₂ ≤ Q ≤ Q ₄	ε	%	±2 for cold water T ≤ 30°C ±3 for water T > 30°C									
Maximum permissible error in the range of Q ₁ ≤ Q < Q ₂	ε	%	±5									
Battery	-	-	2x integrated 3V DC lithium batteries									
RF	-	-	868 MHz up to 25 mW E.R.P. EU868 MHz LoRa up to 25 mW E.R.P.									
RF communication standard	-	-	OMS-compliant WM-Bus OMS-compliant WM-Bus + LoRaWAN									
Radio transmission mode (WM-Bus)	-	-	C1									
Water pressure class	(EN)	-	bar		MAP16							
	(OIML)	-	bar		0.3 to 16							
Pressure loss class at Q ₃	(EN)	ΔP	ΔP40 at T30, T50 ΔP25 at T70					ΔP40 dla T30, T50				
	(OIML)	-	bar		0.4					0.25		
	manufacturer-specified	-	bar		0.25	0.25	0.28	0.26	0.17	0.24		
Installation orientation	-	-	H, V, H/V									
Reverse flow (manufacturer-specified)	-	-	Reverse flow metering by design									
Relative humidity	-	%	≤ 100									
IP rating	-	-	IP68									
Water meter body material			brass	composite	brass	composite	brass					
Connection end thread size	G	Inch	¾"; 7/8 -> ¾" *			1"		1 1/4"	1 1/2"	2"	kołnierz***	
	G1	mm	-									
Water meter length	L	mm	80	110	80	105	130	105	165	260	300	200; 270;
			115	165	110	115	190	130	260			300

* Thread size 7/8 -> ¾" available for 115 mm long versions only

**Applies to thread size 7/8 -> ¾"

Specification			Ultrimis NEO									
			ULN 2.5		ULN 2.5-01	ULN 4		ULN 4-01	ULN6,3	ULN10	ULN16	ULN25
Height	H	mm	71.20; 72.20**		71.20	77.85		81.96	88.4	98.31	111.09	
	H1	mm	73.68			80.33		86,33	92.76	102.67	115.47	
	H2	mm	160.08			166.73		174.76	181.2	191.11	203,89	
	h	mm	13.25; 14.25**		13.25	16.58		20.96	23.9	29.81	72	
Counter size	D	mm	92.2									
Flange size	Dz	mm	-									
Weight	-	kg	0.48	0.52	0.29	0.61	0.63	0.33	1.05	1.68	2.15	6.29; 6.75; 6.95
			0.53	0.6	0.31	0.66	0.77	0.34	1.39			

* Thread size 7/8 -> 3/4" available for 115 mm long versions only

**Applies to thread size 7/8 -> 3/4"

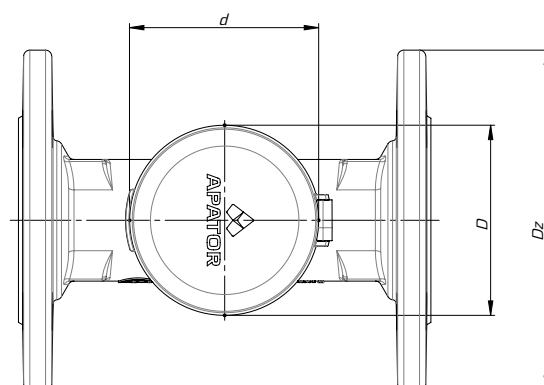
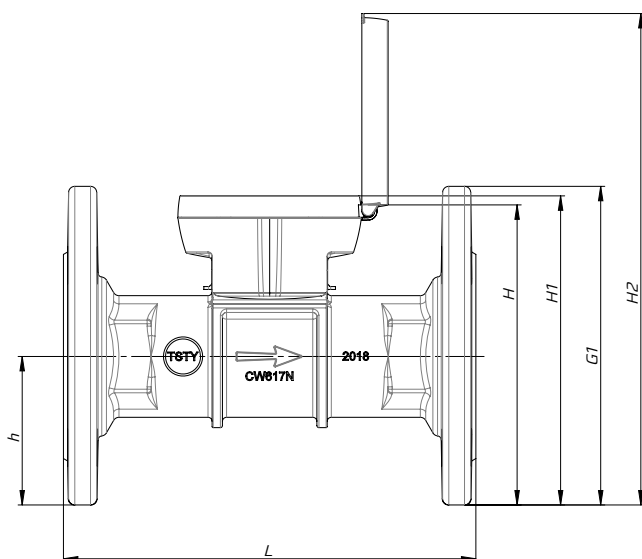
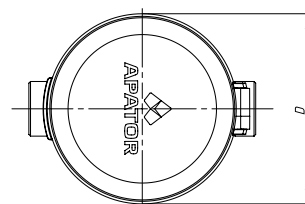
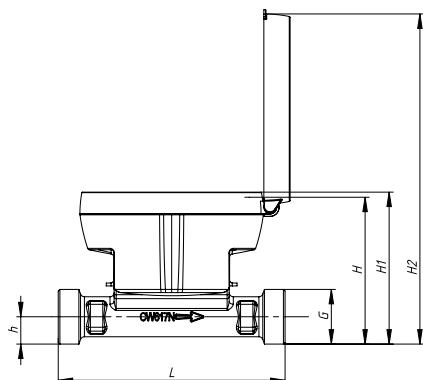

Pressure loss chart

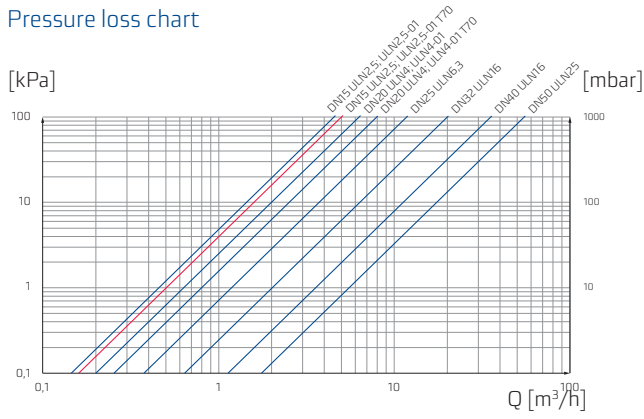

Connection fittings

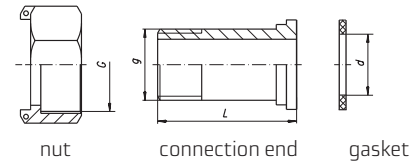

DN	G	g	d	L
	inch	inch	mm	mm
15	3/4"	1/2"	17	37.5
20	1"	3/4"	23	45.6
25	1 1/4"	1"	29	46.5
32	1 1/2"	1 1/4"	36	56
40	2"	1 1/2"	43	66
50	2 1/2"	2"	54	74.2

Typical error chart

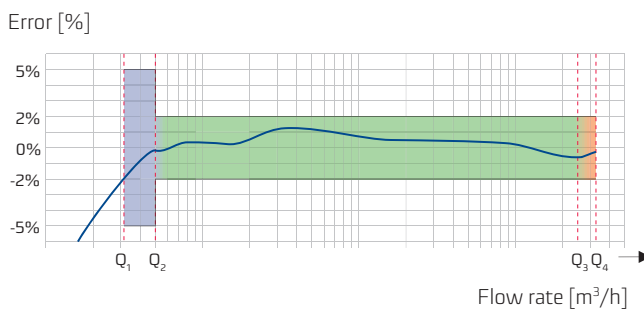

Installation, configuration and remote reading

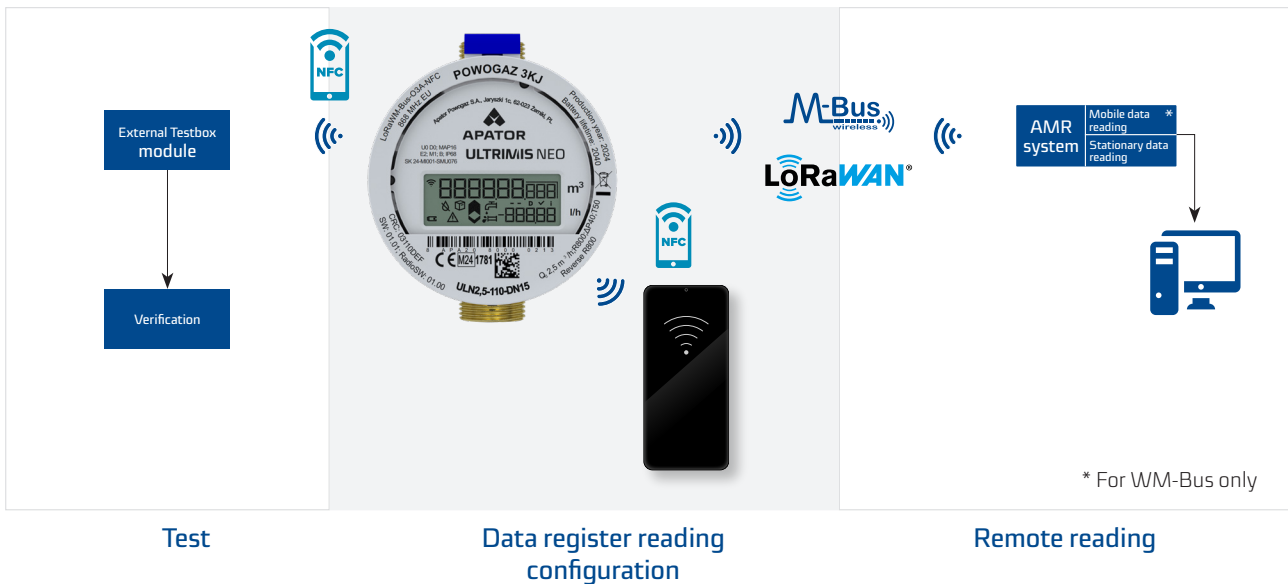

Available options:

- Disposable clamps with snap-on seals made of plastic, with unique ID numbers
- Half unions with gaskets
- Water meter brackets
- Testbox
- Bluetooth to RF or USB converter

The data presented in the data sheet was correct on the date of publication.
The manufacturer reserves the right to modify and improve its products without notice.
This publication is intended for information purposes only and shall not be construed as a commercial offer under the Polish Civil Code.



Apator Powogaz S.A.

Jaryszki 1c, 62-023 Żerniki, Poland

Office: sekretariat.powogaz@apator.com, tel. +48 61 84 18 101

Sales / Customer Service: tel.: +48 61 84 18 149

Customer Service Centre Support: handel.powogaz@apator.com

Export: export.powogaz@apator.com

Technical Support: support.powogaz@apator.com, tel. +48 61 8418 131, 134, 294

Warranty Claims: reklamacje.powogaz@apator.com