



User Manual

Three Phase Smart DC Meter

HXE310 EU

Focus on creating value for clients

Revision history

Index	Date	Name	Remarks
1.0	Jun. 22th. 2024	HEXING	First Release
1.1	July. 1st. 2024	HEXING	Update
1.2	July. 12th. 2024	HEXING	<ol style="list-style-type: none">1. Add explanation for the auxiliary terminal2. Correct the mistake of description of OBIS3. Add BS for the Dimension
1.2.1	Aug. 12th. 2024	HEXING	<ol style="list-style-type: none">1. Update the dimension of meter description, delete long terminal cover 60mm, add the Note for terminal space and meter hanger.
1.2.2	Aug.20 th .2024	HEXING	<ol style="list-style-type: none">1. Correct the name of HEXING.
1.2.3	Aug.27th.2024	HEXING	Update the LCD display information of letter "V".

Document description

Effective coverage:

This user manual only applies to Hexing meter type as mentioned in the document title.

Objective:

This user manual includes the relevant technical information of meter. It is available for the use and maintenance of the meter. The manual includes:

- Introduction of meter's work mechanism, performance and functions.
- Malfunction that may happen during its lifetime and the corresponding precaution.
- Detailed description of the meter functioning during its whole lifetime.

User Object:

- This user manual aims at guiding the personnel responsible for the meter design, testing, operation etc.
- This user manual is also helpful for personnel from the electricity company such as the meter engineers and the technicians responsible for the meter installation, operation and maintenance from the electricity company as well.

Copyright © 2024 HEXING TECHNOLOGIES EUROPE S.R.L. All rights reserved.

No part of this publication may be reproduced, transmitted, stored in a retrieval system, or translated into any language in any form by any means without the written permission of HEXING TECHNOLOGIES EUROPE S.R.L. All trademarks are acknowledged.

HEXING TECHNOLOGIES EUROPE S.R.L.

Sat Giarmata, Comuna Giarmata,

DJ 691 KM 8 + 775 M DREAPTA,

Judet Timis, Romania.

Phone: +40 742058188

Email: Europe@hxgroup.com

HEXING TECHNOLOGIES EUROPE S.R.L.

Sat Giarmata, Comuna Giarmata, DJ 691 KM 8 + 775 M DREAPTA, Judet Timis, Romania.

Phone: +40 742058188 Email: Europe@hxgroup.com

Content

1 Overview	1
2 Description of components and sealing.....	2
3 Standards compliance	4
4 Working Principle	5
5 Measurement.....	6
5.1 Legal metrology	6
5.2 Measurement principle	6
5.3 Active energy Measurement	7
5.4 Reactive energy Measurement	7
5.5 Apparent energy Measurement.....	7
5.6 Instantaneous Measurement	8
6 LCD display	9
6.1 LCD with full segments	9
6.2 Display segments.....	9
6.3 Display mode	10
6.4 Number and Letter display information:.....	11
7 Demand.....	12
7.1 Calculation method of MD	12
7.2 MD recorded content.....	12
7.3 MD reset	12
8 Load profile	13
8.1 Load profile capacity	13
8.2 Capture object list	13
9 Billing.....	17
9.1 Daily data	17
9.2 Monthly billing.....	17
10 Relay control(Optional)	20
10.1 Relay control logic(Optional).....	20
10.2 Relay status(Optional)	20
10.3 Relay control command(Optional)	21
10.4 Relay control mode(Optional).....	21

11 Load control(Optional)	22
12 Firmware Upgrade.....	23
13 Event record	24
13.1 Event classification	24
13.2 Event list	24
13.2.1 Standard event list.....	24
13.2.2 Tamper event list.....	24
13.2.3 Relay control event list	25
13.2.4 Power quality event list	25
13.2.5 Communication event list.....	26
14 Back-up power	27
14.1 Battery	27
14.1.1 Low battery detection	27
14.1.2 Battery working lifetime.....	27
14.1.3 External battery replacement	27
14.2 Super capacitor(optional).....	28
15 RTC	29
15.1 DST.....	29
15.1.1 DST configurable.....	29
15.1.2 Restrictive conditions	29
15.2 TOU.....	29
15.2.1 Active and passive tariff	30
16 LED Indication	31
16.1 Active LED indication	31
16.2 Reactive LED indication	31
16.3 Alarm LED indication	31
17 Communication interface.....	32
17.1 Optical communication	32
17.2 RS485 interface	32
17.3 M-Bus interface(Optional).....	32
17.4 P1 port interface(Optional)	32
17.5 GPRS/4G communication(Optional).....	33

17.6 G3-PLC communication(Optional).....	33
17.7 Prime-PLC communication(Optional).....	33
18 Auxiliary interface(Optional).....	34
18.1 Auxiliary port diagram(Optional).....	34
18.2 Auxiliary port function(Optional).....	34
19 Client management.....	35
20 Overall dimensions and installation.....	36
20.1 Meter Connection.....	36
20.1.1 Connection Diagram:.....	36
20.1.2 Auxiliary terminal wiring diagram.....	36
20.2 Meter Dimension.....	38
20.3 Installation dimension drawing.....	39
20.4 Terminal drawing.....	39
21 Installation and un-installation.....	40
21.1 Installation tools.....	40
21.2 Preparation before installation.....	40
21.3 Installation procedure.....	41
21.4 Commissioning test after installation.....	43
21.5 Remove.....	43
22 Service.....	45
22.1 Fault Operation.....	45
22.2 Meter Repair.....	45
23 Maintenance.....	46
23.1 Clean.....	46
23.2 Error and function check.....	46
23.3 Reinstall.....	46
24 Scrap Processing.....	47
25 Transportation and Storage.....	48
26 Parameters.....	49
Annex A Communication and Display OBIS.....	52
Annex B Demand content OBIS list.....	55

1 Overview

The HXE310EU three-phase smart meter is design for measuring the import and export active energy, import and export reactive energy, maximum demand and instantaneous parameters. It supports contract management, multi-tariff, monthly billing, daily billing, load profile, event detection, neutral measurement (optional) and supply control etc. A modular-designed communication module can be GPRS module, or 3G module, or 4G module, or NB-IoT module, or PLC module which supports plug and play while no need to power off the meter. The meter can support integrated PLC communication solution.

Main Features

- Support wide scope of operate voltage
- LCD display with large 8 digits.
- Lithium battery or/and super-capacitor used as back-up power supply, so can support display available in case of power failure.
- Display button allows checking the LCD display items and changing the LCD display mode.
- Support multiple input/output interface and hot plug in/out interface.
- Communication protocol: DLMS/COSEM.
- Communication encryption ensures data transmission safety.
- Support local and remote firmware upgrade.
- Support relay on/off remotely.
- Support Degree Protection IP54
- Real-time clock
- Various events detection and record including under voltage, over voltage, programming, password setting and time setting
- Tamper detect: cover open, current bypass, magnetic, phase reverse, etc.
- Built-in Prime-PLC, Bluetooth, wireless M-bus communication module selectable.

2 Description of components and sealing

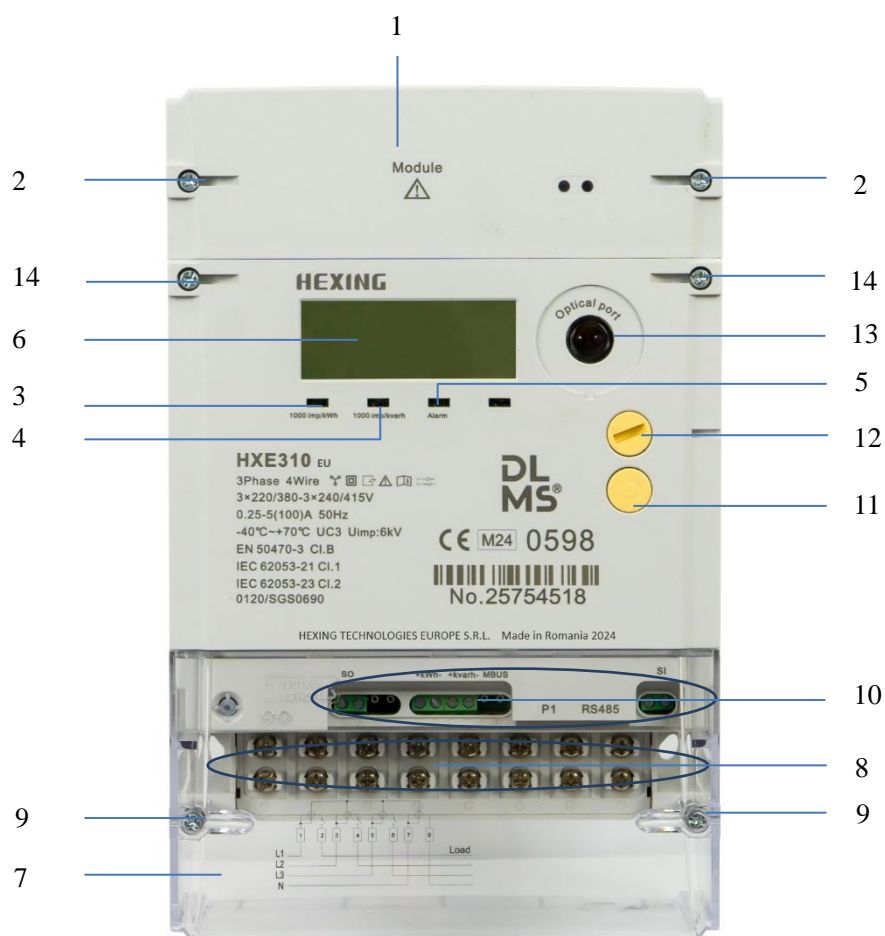

- | | | |
|------------------------------|-------------------------|--------------------------|
| 1. Communication module | 6. LCD window | 11. Display button |
| 2. Communication module seal | 7. Terminal cover | 12. Sealable button |
| 3. Active pulse LED | 8. Terminal Block | 13. Optical port |
| 4. Reactive pulse LED | 9. Terminal cover seal | 14. Terminal cover seals |
| 5. Alarm LED (optional) | 10. Auxiliary interface | |

The meter has six safety seals:

- 1) Two seals are for the communication module
- 2) Two seals for the meter housing
- 3) A seal is for the sealing button (optional)
- 4) Two seal is for the terminal cover

It is impossible to touch the metrological part of the meter if you do not physically and transparently destroy it the seals and the upper cover of the meter or the terminal cover.

The image below shows the sealing position of the meter.

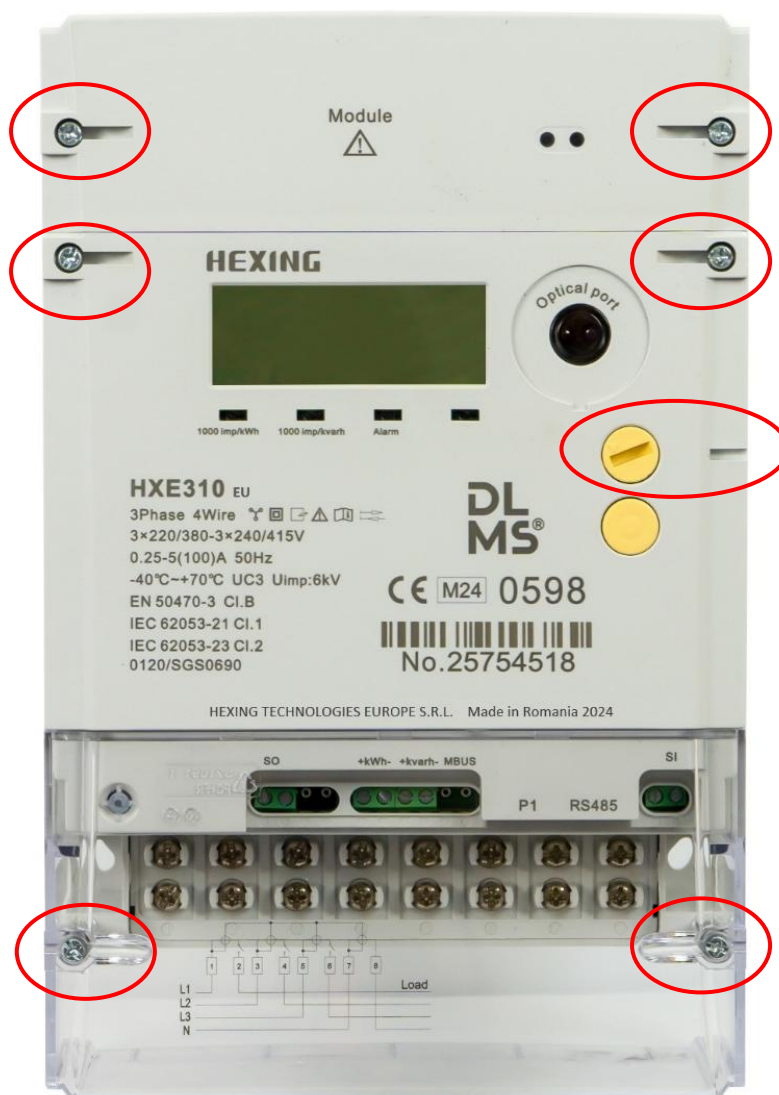

3 Standards compliance

Standard	Description
IEC 62053-21:2020	Electricity metering equipment –Particular requirements –Part 21: Static meters for AC active energy (classes 0,5, 1 and 2)
IEC 62053-23:2020	Electricity metering equipment – Particular requirements – Part 23: Static meters for reactive energy (classes 2 and 3)
EN IEC 62052-11: 2021 +A11:2022	Electricity metering equipment – General requirements, tests and test conditions – Part 11: Metering equipment
EN 50470-3:2022	Electricity metering equipment – Part 3: Particular requirements – Static meters for AC active energy (class indexes A, B and C)
IEC 62052-31:2015	Electricity metering equipment (AC) – General requirements, tests and test conditions –Part 31: Product safety requirements and tests
IEC 62052-21	Electricity metering equipment (AC) – General requirements, tests and test conditions – Part 21: Tariff and load control equipment
IEC 62056-21	Electricity metering - Data exchange for meter reading, tariff and load control – Part 21: Direct local data exchange
IEC62056-42	Electricity metering – Data exchange for meter reading, tariff and load control – Part 42:Physical layer services and procedures for connection-oriented asynchronous data exchange
IEC62056-46	Electricity metering – Data exchange for meter reading, tariff and load control – Part 46: Data link layer using HDLC protocol
IEC62056-47	Electricity metering – Data exchange for meter reading, tariff and load control – Part 47:COSEM transport layer for IP networks
IEC62056-53	Electricity metering – Data exchange for meter reading, tariff and load control – Part 53:COSEM Application layer
IEC62056-61	Electricity metering – Data exchange for meter reading, tariff and load control – Part 61:OBIS Object identification system
IEC62056-62	Electricity metering – Data exchange for meter reading, tariff and load control – Part 62:Interface classes

4 Working Principle

The HXE310EU three-phase smart meter consists of five main parts:

- The measuring unit that includes the voltage sampling circuit, the circuit of current sampling and IC measurement.
- The data processing unit that includes the microcontroller, the memory chip and the internal clock real time (RTC).
- the power supply unit, which includes the AC power supply and the AC power supply battery.
- The import and export unit that includes the LCD display, the optical communication port, PLC / GPRS / RF communication,
- The load control unit, which includes the relay control circuit.

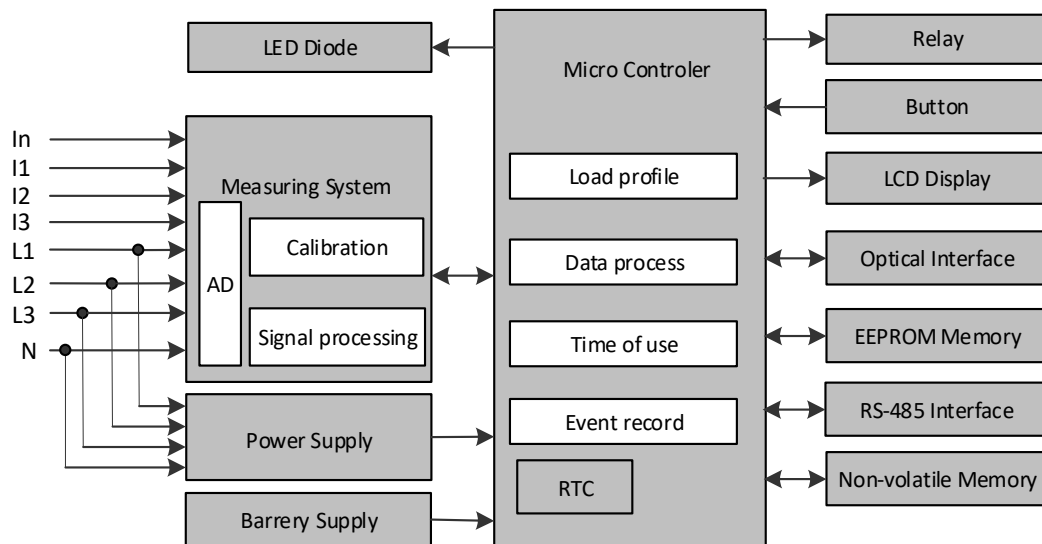

Diagrams of the principles of operation

5 Measurement

5.1 Legal metrology

The legally relevant software consists of metrological part that is the essential part, and support functions such as hardware driver, metrological data procedure, software download, clock and calendar, tariff and protective interface used to communicate with the non-legally relevant software.

The legally relevant software is independent from the non-legally relevant software that any changes occur to non-legally part will not influence the legally relevant part.

The software version number and checksum of legally metrological part as below:

Items	Display OBIS Code	Value	LCD display information
Software version No.	0.2.0	310_V31	
CRC Checksum	0.2.8	84C4A711	

5.2 Measurement principle

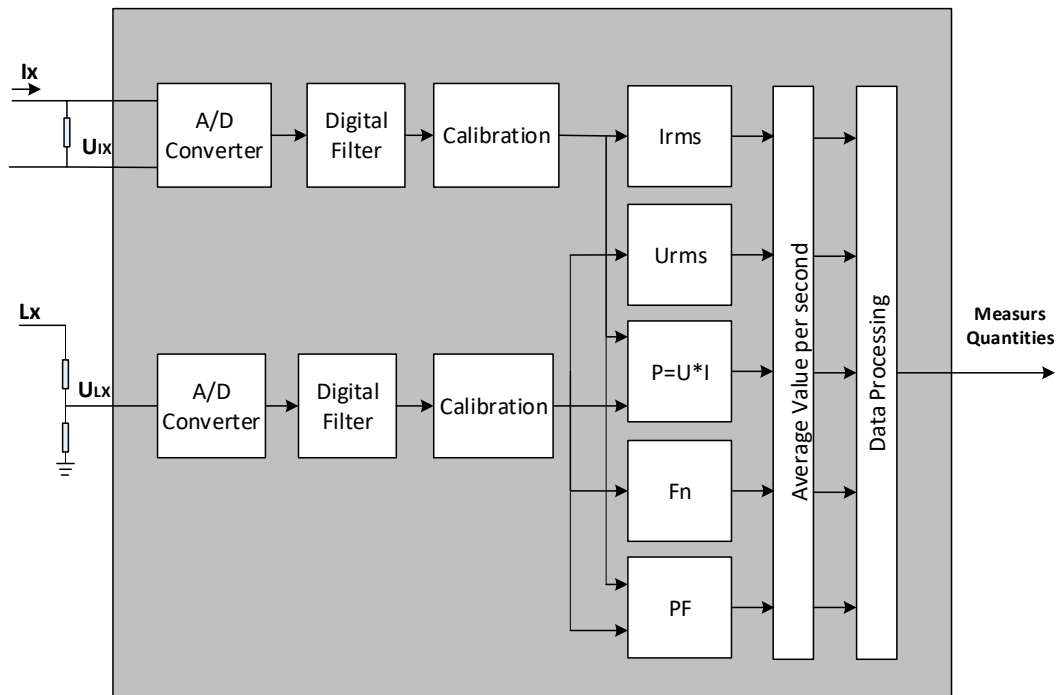

Signal convertor and processing flow chart

- **Digitizing:**

HEXING TECHNOLOGIES EUROPE S.R.L.

Sat Giarmata, Comuna Giarmata, DJ 691 KM 8 + 775 M DREAPTA, Judet Timis, Romania.

Phone: +40 742058188 Email: Europe@hxgroup.com

The input analogue signals is converted by AD converter in measuring system and then filtered. After that, the signals are calibrated and finally form the required digital instantaneous values.

- **Mean value formation:**

From digital instantaneous values, measuring system calculates the mean values per second by integral calculus. Then the microprocessor scans these values at intervals of one second for further processing.

- **Algorithms**

Active power: $P = U * I * PF = U * I$ with unit kW and 3 decimal place.

Active energy: $E = \int P dt$ calculate period one second, with unit kWh and 2 decimal place.

5.3 Active energy Measurement

+A=A₊, -A=A₋

- Total Import active energy per tariff
- Total Export active energy per tariff
- Total Sum active energy per tariff
- Total Net active energy per tariff
- Import active energy in L1
- Export active energy in L1
- Import active energy in L2
- Export active energy in L2
- Import active energy in L3
- Export active energy in L3

5.4 Reactive energy Measurement

+R=R_I+R_{II}, -R=R_{III}+R_{IV}

- Total Import reactive energy per tariff
- Total Export reactive energy per tariff
- Total Reactive energy per tariff in Q_I
- Total Reactive energy per tariff in Q_{II}
- Total Reactive energy per tariff in Q_{III}
- Total Reactive energy per tariff in Q_{IV}
- Import reactive energy in L1
- Export reactive energy in L1
- Import reactive energy in L2
- Export reactive energy in L2
- Import reactive energy in L3
- Export reactive energy in L3

5.5 Apparent energy Measurement

- Import apparent energy
- Export apparent energy
- Import apparent energy in L1

HEXING TECHNOLOGIES EUROPE S.R.L.

Sat Giarmata, Comuna Giarmata, DJ 691 KM 8 + 775 M DREAPTA, Judet Timis, Romania.
Phone: +40 742058188 Email: Europe@hxgroup.com

- Export apparent energy in L1
- Import apparent energy in L2
- Export apparent energy in L2
- Import apparent energy in L3
- Export apparent energy in L3

5.6 Instantaneous Measurement

- Voltage
- Current
- Active power
- Reactive power
- Apparent power
- V&I Phase Angles
- BA voltage angle, CA voltage angle
- Power factor
- Frequency

6 LCD display

6.1 LCD with full segments



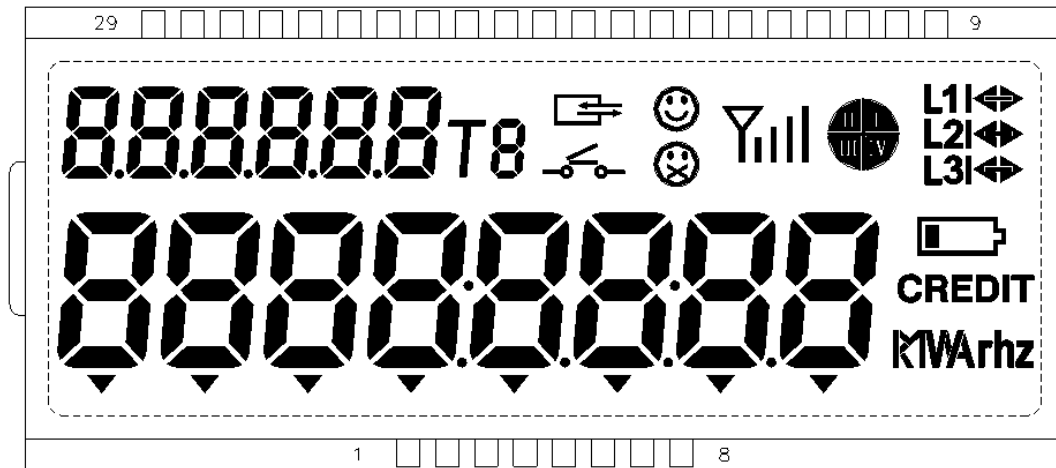

LCD with full-segment display is as following.



- LCD material is HTN type, and its working temperature range is -40°C~+70°C.
- LCD shall be high contrast ratio.
- LCD shall be wide viewing angle.
- LCD polarizer shall be anti-ultraviolet function.

6.2 Display segments

LCD display information	Description
	Data display
	OBIS display
L1 L2 L3	Indicates current voltage: 1) On: The voltage is normal 2) Off: Power failure 2) Flashing: Under voltage, Overvoltage, Loss voltage
kWhrhz	Unit
	The meter is in communication
	Four-quadrant indicator

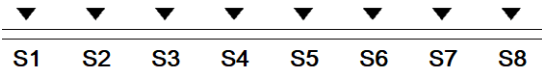
	<p>Indicate the direction of the power</p> <p>1) Right arrow: Import</p> <p>2) Left arrow: Export</p> <p>3) No displayed or displayed as input power: grid power on but no import</p> <p>4) Not display: when voltage indicator has no display</p>
	<p>Battery status</p>
	<p>Relay connection/disconnection</p>
	<p>Strength of signal status</p>
	<p>Tariff indicator</p>
	<p>S1~S8: event status indicator (Optional)</p> <p>For example:</p> <p>S1: Magnetic</p> <p>S2: DST</p> <p>S3: Meter cover open</p> <p>S4: Terminal cover open</p> <p>S5: Test mode</p> <p>S6: Reserve</p> <p>S7: Reserve</p> <p>S8: Reserve</p> <p>Note: it is configurable according to the customer requirement in factory. the supported items can be: meter cover open, terminal cover open, strong magnetic field detected, overload, bypass, clock invalid, DST, test mode and etc.</p>

6.3 Display mode

This meter is able to supports 4 display modes:

Automatic mode display

Meter default display mode is auto-scrolling display, the default auto scrolling time cycle is 8 seconds. The time in each cycle is configurable between (1s-60s) time interval; it will switch to the next screen display automatically. Auto-scrolling display item list is also configurable with 60 items, detailed display information please check the display list.

Manual mode display

Manual display mode can be activated by pressing the display button, a short and repeated press of display button will change the screen display. Meter will return to auto-scrolling display mode automatically in a certain time without operating (default 60s). The display item list under Manual mode display is configurable, and 60

HEXING TECHNOLOGIES EUROPE S.R.L.

Sat Giarmata, Comuna Giarmata, DJ 691 KM 8 + 775 M DREAPTA, Judet Timis, Romania.
 Phone: +40 742058188 Email: Europe@hxgroup.com

items can be configured at minimum, detailed display information please check the display list.

Power off display

The LCD will off as default status. The meter will show power off display by pressing the button, the item list of power off is the same as that under auto mode, the LCD will be off after predefined time. In order to reduce battery consumption, the power off display can be activated only 5 times on a power failure period. When the battery is lower the threshold of low battery, power off display cannot be activated.

Test mode

Meter can enter or exit the test mode by receiving a command. In test mode, the meter will display the energy in high resolution (with 3 to 4 decimals).

Also, the meter will exit the test mode automatically after 2 hours.

6.4 Number and Letter display information:

Number: 0~9



Letters: A~Z



A B C D E F G H I J K L M



N O P Q R S T U V W X Y Z

7 Demand

7.1 Calculation method of MD

Support two types of MD calculation methods: sliding window time and block. MD sliding time can be set between from 1 to 60 minutes, and MD sliding number can be set between 1~15, and the sliding time and number should not be more than 60 by multiplication.

7.2 MD recorded content

- Import active demand
- Import reactive demand
- Export active demand
- Export reactive demand
- Reactive demand in QI
- Reactive demand in QII
- Reactive demand in QIII
- Reactive demand in QIV
- Import apparent demand
- Export apparent demand
- Active demand ($|QI+QIV|+|QII+QIII|$)
- Total import active MD with time stamp per tariff
- Total export active MD with time stamp per tariff
- Total import reactive MD with time stamp per tariff
- Total export reactive MD with time stamp per tariff
- Total reactive MD with time stamp per tariff in QI
- Total reactive MD with time stamp per tariff in QII
- Total reactive MD with time stamp per tariff in QIII
- Total reactive MD with time stamp per tariff in QIV
- Total import apparent MD with time stamp per tariff
- Total export apparent MD with time stamp per tariff
- Total active MD ($|QI+QIV|+|QII+QIII|$) with time stamp per tariff

7.3 MD reset

There are three ways to reset the MD:

Automatic reset

Reset according to the time preset, usually the same with billing time.

Command reset

Send a command from system or software to reset the MD.

8 Load profile

8.1 Load profile capacity

Load Profile	Default application	Max. capture items	Profile total bytes
Load Profile 1	Hourly Data(energy)	60	500k bytes (8 channels, 15min, 90days)
Load Profile 2	Hourly Data(Instantaneous)	60	500k bytes (8 channels, 15min, 90days)
Load Profile 9	Daily Billing Data	60	20k bytes (60 channels, 62days)

- The period can be setting from 1-1440mins, when you choose 0, means no need for this profile.
- Each profile capacity can be set in factory.
- When you change the objects list or the period of the profile, the data will be erased.
- The average, minimum and maximum value of the instantaneous data can only be configuring in only one load profile (either in Load profile 1 or in Load profile 2), consult the engineer for details.

Note: the data storage period is able to update according to the customer's requirements before delivery.

8.2 Capture object list

Object	Number of bytes
Clock	14
Load profile status word	2
Import active energy	5
Export active energy	5
Combined active energy	5
Import active energy in L1	5
Export active energy in L1	5
Import active energy in L2	5
Export active energy in L2	5
Import active energy in L3	5
Export active energy in L3	5
Reactive energy in QI	5
Reactive energy in QII	5
Reactive energy in QIII	5
Reactive energy in QIV	5
Reactive energy in QI in L1	5
Reactive energy in QII in L1	5
Reactive energy in QIII in L1	5
Reactive energy in QIV in L1	5
Reactive energy in QI in L2	5
Reactive energy in QII in L2	5
Reactive energy in QIII in L2	5

Reactive energy in QIV in L2	5
Reactive energy in QI in L3	5
Reactive energy in QII in L3	5
Reactive energy in QIII in L3	5
Reactive energy in QIV in L3	5
Import reactive energy	5
Export reactive energy	5
Import reactive energy in L1	5
Export reactive energy in L1	5
Import reactive energy in L2	5
Export reactive energy in L2	5
Import reactive energy in L3	5
Export reactive energy in L3	5
Import apparent energy	5
Export apparent energy	5
Import apparent energy in L1	5
Export apparent energy in L1	5
Import apparent energy in L2	5
Export apparent energy in L2	5
Import apparent energy in L3	5
Export apparent energy in L3	5
Import active energy tariff [x]	5
Export active energy tariff [x]	5
Import reactive energy tariff [x]	5
Export reactive energy tariff [x]	5
Reactive energy tariff [x] in QI	5
Reactive energy tariff [x] in QII	5
Reactive energy tariff [x] in QIII	5
Reactive energy tariff [x] in QIV	5
Import apparent energy tariff [x]	5
Export apparent energy tariff [x]	5
Combined active energy tariff [x]	5
Import active energy (interval)	5
Export active energy (interval)	5
Import reactive energy (interval)	5
Export reactive energy (interval)	5
Last reactive demand Q1	5
Last reactive demand Q2	5

HEXING TECHNOLOGIES EUROPE S.R.L.

Sat Giarmata, Comuna Giarmata, DJ 691 KM 8 + 775 M DREAPTA, Judet Timis, Romania.
 Phone: +40 742058188 Email: Europe@hxgroup.com

Last reactive demand Q3	5
Last reactive demand Q4	5
Last import apparent demand	5
Last export apparent demand	5
Last average value of voltage L1	5
Last average value of voltage L2	5
Last average value of voltage L3	5
Last average value of current L1	5
Last average value of current L2	5
Last average value of current L3	5
Last average value of power factor L1	5
Last average value of power factor L2	5
Last average value of power factor L3	5
Last average value of power factor	5
Last average value of import active power	5
Last average value of export active power	5
Last average value of import reactive power	5
Last average value of export reactive power	5
Last Maximum value of voltage L1	5
Last Maximum value of voltage L2	5
Last Maximum value of voltage L3	5
Last Maximum value of current L1	5
Last Maximum value of voltage L2	5
Last Maximum value of voltage L3	5
Last Maximum value of power factor L1	5
Last Maximum value of power factor L2	5
Last Maximum value of power factor L3	5
Last Maximum value of power factor	5
Last Maximum value of import active power	5
Last Maximum value of export active power	5
Last Maximum value of import reactive power	5
Last Maximum value of export reactive power	5
Last Minimum value of voltage L1	5
Last Minimum value of voltage L2	5
Last Minimum value of voltage L3	5
Last Minimum value of current L1	5
Last Minimum value of current L2	5
Last Minimum value of current L3	5

HEXING TECHNOLOGIES EUROPE S.R.L.

Sat Giarmata, Comuna Giarmata, DJ 691 KM 8 + 775 M DREAPTA, Judet Timis, Romania.
 Phone: +40 742058188 Email: Europe@hxgroup.com

Last Minimum value of power factor L1	5
Last Minimum value of power factor L2	5
Last Minimum value of power factor L3	5
Last Minimum value of power factor	5
Last Minimum value of import active power	5
Last Minimum value of export active power	5
Last Minimum value of import reactive power	5
Last Minimum value of export reactive power	5

9 Billing

9.1 Daily data

- Up to 62 days data
- Freezing time: 00:00 at midnight everyday
- Freezing content: Can be configured (item 8.2)
- Period: 1440 minutes.

9.2 Monthly billing

Capacity:

At least store 14 items of monthly billing data

Automatic billing:

When meter passes the preset billing time, the meter will freeze the monthly billing data automatically. The format is XX day XX hour, and the default is 00 clock on the first day of each month.

Manual billing:

Support sending command or press-button billing. Long press the seal button for 10 seconds, the meter will display “-PrESS-bl”, then press any button and the meter will display “done”, which means press-button billing has finished. This function can be configured as enable or disable. There is a blocking period to avoid repeated operation of manual billing in short time.

Support supplement latest one billing data when meter power off or clock adjust.

Support configuring maximum 60 objects one time, the list is as follows:

- Clock
- Meter serial number
- Import active energy
- Export active energy
- Import active energy in L1
- Export active energy in L1
- Import active energy in L2
- Export active energy in L2
- Import active energy in L3
- Export active energy in L3
- Combined active energy
- Reactive energy in QI
- Reactive energy in QII
- Reactive energy in QIII
- Reactive energy in QIV
- Reactive energy in QI in L1
- Reactive energy in QII in L1

- Reactive energy in QIII in L1
- Reactive energy in QIV in L1
- Reactive energy in QI in L2
- Reactive energy in QII in L2
- Reactive energy in QIII in L2
- Reactive energy in QIV in L2
- Reactive energy in QI in L3
- Reactive energy in QII in L3
- Reactive energy in QIII in L3
- Reactive energy in QIV in L3
- Import reactive energy
- Export reactive energy
- Import reactive energy in L1
- Export reactive energy in L1
- Import reactive energy in L2
- Export reactive energy in L2
- Import reactive energy in L3
- Export reactive energy in L3
- Import apparent energy
- Export apparent energy
- Import apparent energy in L1
- Export apparent energy in L1
- Import apparent energy in L2
- Export apparent energy in L2
- Import apparent energy in L3
- Export apparent energy in L3
- Import active energy tariff [x]
- Export active energy tariff [x]
- Import reactive energy tariff [x]
- Export reactive energy tariff [x]
- Reactive energy tariff [x] in QI
- Reactive energy tariff [x] in QII
- Reactive energy tariff [x] in QIII
- Reactive energy tariff [x] in QIV
- Import apparent energy tariff [x]
- Export apparent energy tariff [x]
- Combined active energy tariff [x]
- Import active MD with time stamp
- Import active MD with time stamp tariff[X]
- Export active MD with time stamp
- Export active MD with time stamp tariff[X]
- Import reactive MD with time stamp
- Import reactive MD with time stamp tariff[X]
- Export reactive MD with time stamp

HEXING TECHNOLOGIES EUROPE S.R.L.

- Export reactive MD with time stamp tariff[X]
- Active MD ($|QI+QIV|+|QII+QIII|$) with time stamp
- Active MD ($|QI+QIV|+|QII+QIII|$) with time stamp tariff[X]
- Reactive MD with time stamp in QI
- Reactive MD with time stamp tariff[X] in QI
- Reactive MD with time stamp in QII
- Reactive MD with time stamp tariff[X] in QII
- Reactive MD with time stamp in QIII
- Reactive MD with time stamp tariff[X] in QIII
- Reactive MD with time stamp in QIV
- Reactive MD with time stamp tariff[X] in QIV
- Import Apparent MD with time stamp
- Import Apparent MD with time stamp tariff[X]
- Export Apparent MD with time stamp
- Export Apparent MD with time stamp tariff[X]

10 Relay control(Optional)

10.1 Relay control logic(Optional)

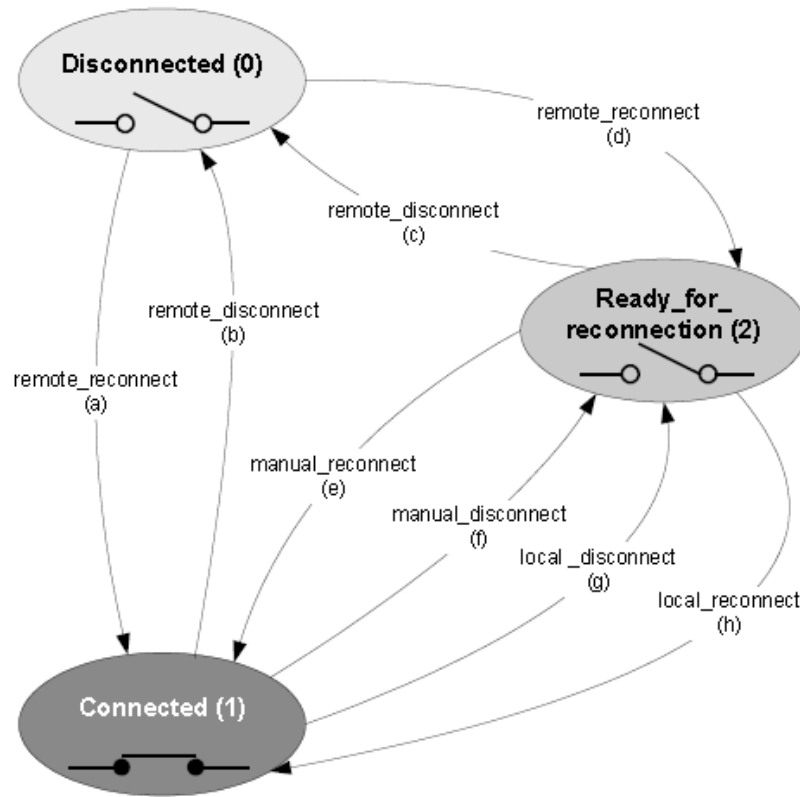

Relay control logic figure

Remote control: means send command to disconnect/connect.

Manual control: means press button to disconnect/connect. The relay symbol on the LCD will flash when the relay status is "Ready for Connection", then long press the display button 6S to reconnect the relay. After reconnect the relay, the relay symbol will return to normal display. When the mode is supported, press the sealable button and the display button 6S at same time to manually break the switch.

Local control: means make use of the meter own function to realize power/current control, etc.



WARNING

Warning: The open position of the relay (disconnection) does not provide isolation from the mains network.

10.2 Relay status(Optional)

No.	Status	Description
0	Disconnected(0)	In this status, relay is off, Any other operation is not allowed except that system or PC software send the cancel relay off command
1	Connected(1)	In this status, relay is on
2	Ready for connected(2)	In this status, relay is off

10.3 Relay control command(Optional)

Transform No.	Transfer Name	Transform explain
a	Remote_reconnect	Remote reconnect, From Disconnected(0) to Connected(1), donnecneed manual control
b	Remote_disconnect	Remote disconnect, From Connected(1) to Disconnected(0)
c	Remote_disconnect	Remote disconnect, From Ready for connected(2) to Disconnected(0)
d	Remote_reconnect	Remote reconnect, From Disconnected(0)to Ready for connected(2) From Ready for connected(2) to Connected(1) need local or manual command
e	Manual_reconnect	Manual reconnect, From Ready for connected(2) to connected(1)
f	Manual_disconnect	Manual disconnect, From Connected(1) to Ready for connected(2) From Ready for connected(2) to Connected(1) need local or manual command
g	Local_disconnect	Local disconnect, From Connected(1) to Ready for connected(2) From Ready for connected(2) to Connected(1) need local or manual command
h	Local_reconnect	Local reconnect, From Ready for connected(2) to Connected(1)

10.4 Relay control mode(Optional)

The relay control mode can be set by HEXVIEW software.

Control mode	Disconnection				Reconnection			
	Remote		Manual	Local	Remote		Manual	Local
	b	c	f	g	a	d	e	h
0	-	-	-	-	-	-	-	-
1	x	x	x	x	-	x	x	-
2	x	x	x	x	x	-	x	-
3	x	x	-	x	-	x	x	-
4	x	x	-	x	x	-	x	-
5	x	x	x	x	-	x	x	x
6	x	x	-	x	-	x	x	x

11 Load control(Optional)

Load control monitor object can be total instantaneous active power (import + export), total instantaneous import active power, total instantaneous export active power, Maximum current in three phase, Maximum active power in three phase.

Overload disconnect logic:

- When load is higher than the preset threshold A and duration the preset delay time B, relay will disconnect, relay status turns from connected to ready for reconnection
- After relay is disconnect, it will keep this status for a preset time C, relay will turn connected and detect the load again
- If overload counts more than D times, relay will not execute off/on again, relay will keep the initial status (consumer can decide to turn off or on by himself), this initial status called G.
- If overload does not happen in E minutes, the meter will restart the overload counts.

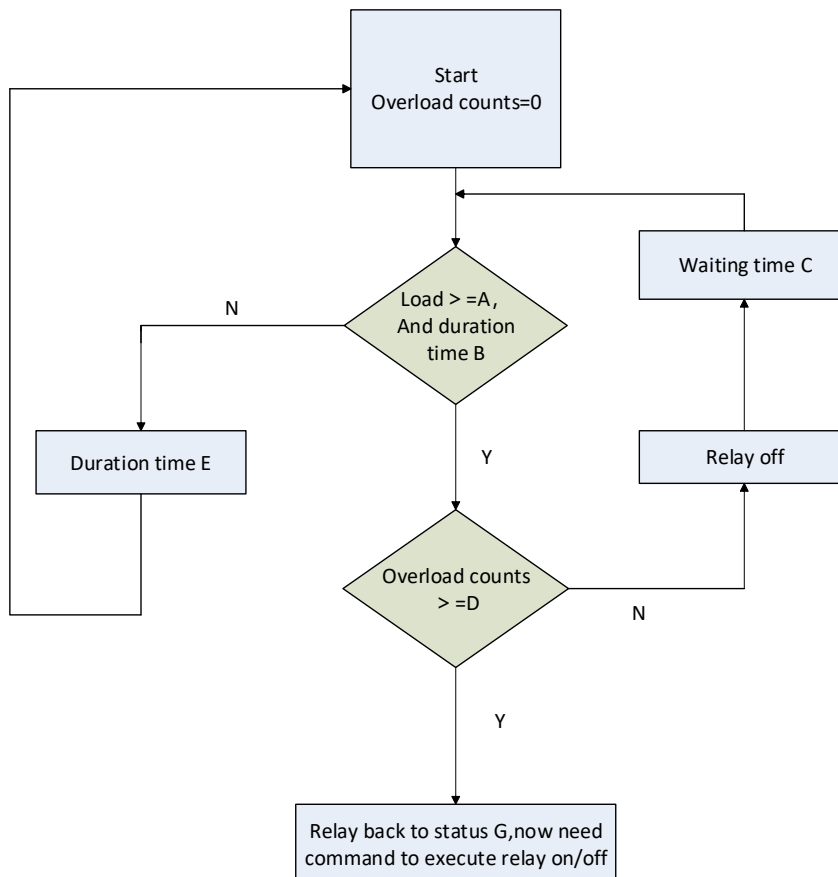

12 Firmware Upgrade

Meter and communication module firmware can be upgraded remotely and/or locally. Firmware upgrade will not work in meter and module until the new version of firmware is uploaded into the meter completely. The meter records the event log as the firmware upgrade.

The meter is fully compliant with the upgrade process defined in the DLMS standard:

- Step 1: Get Image Block Size
- Step 2: Client initiates Image transfer
- Step 3: Client transfers Image Blocks
- Step 4: Client checks completeness of the Image
- Step 5: Server verifies the Image (Initiated by the client or on its own)
- Step 6: Client checks the information on the images to activate
- Step 7: Server activates the Image(s) (Initiated by the client or on its own)

After writing the firmware into meter, meter should check all steps right or not, if the CRC of the firmware is correct, then can update new firmware.

If result of checking for authenticity is negative, the meter will reject to upgrade.

13 Event record

13.1 Event classification

- Standard event
- Tamper event
- Relay control event
- Power quality event
- Communication event

13.2 Event list

13.2.1 Standard event list

Code	Standard Event
1	Power down
2	Power up
3	Daylight saving time enabled or disabled
4	Clock adjusted (old date/time)
5	Clock adjusted (new date/time)
6	Clock invalid
7	Replace battery
8	Low Battery Voltage
9	TOU activated
10	Error register cleared
11	Alarm register cleared
12	Program memory error
13	RAM error
14	NV memory error
15	Watchdog error
16	Measuring system error
17	Firmware ready for activation
18	Firmware activated
19	Programmed passive TOU
47	Change one or more parameters
48	Changing global key (s)
51	Failed FW verification
52	Unexpected consumption
88	Reverse phase sequence
89	Missing neutral
254	Load profile cleared
255	Event log cleared

13.2.2 Tamper event list

Code	Tamper Event
40	Terminal Cover Open

41	Terminal cover close
42	Magnetic Influence Detection start
43	Magnetic Influence Detection end
44	Meter Cover Open
45	Meter Cover close
46	Association authentication failure (n-time failed authentication)
49	Decryption or authentication failure (n-time failure)
50	Replay attack
91	Reverse current
255	Event log cleared

13.2.3 Relay control event list

Code	Relay Control Event
59	Disconnect ready for manual reconnection
60	Manual disconnection
61	Manual connection
62	Remote disconnection
63	Remote connection
64	Local disconnection
65	Limiter threshold exceeded
66	Limiter threshold ok
67	Limiter threshold changed
68	Disconnect/Reconnect failure
69	Local reconnection
255	Event log cleared

13.2.4 Power quality event list

Code	Power Quality Event
76	Under voltage L1
77	Under voltage L2
78	Under voltage L3
79	Over voltage L1
80	Over voltage L2
81	Over voltage L3
82	Missing voltage L1
83	Missing voltage L2
84	Missing voltage L3
85	Voltage L1 normal
86	Voltage L2 normal
87	Voltage L3 normal
90	Phase asymmetry
92	Bad Voltage Quality L1
93	Bad Voltage Quality L2
94	Bad Voltage Quality L3

255	Event log cleared
-----	-------------------

13.2.5 Communication event list

Code	Communication Event
140	No connection timeout
141	Modem initialization failure
142	SIM card failure
143	SIM card Ok
144	GSM registration failure
145	GPRS registration failure
146	PDP context established
147	PDP context destroyed
148	PDP context failure
149	No Valid PDP context(s) retrieved
150	Modem HW reset
151	GSM outgoing connection
152	GSM incoming connection
153	GSM hang-up
154	Diagnostic failure
155	User initialization failure
156	Signal quality low
157	Auto answer number of calls exceeded
158	Local communication attempt

14 Back-up power

14.1 Battery

The meter has a 1200mA internal lithium battery and 1200mA external changeable lithium battery (optional). When the meter powers off, the battery supplies for RTC, LCD display and event recorded.

14.1.1 Low battery detection

When the meter is power on, the voltage will be measured by AD sampling per second.

The accuracy of voltage measuring is $\pm 0.1V$.

When the battery has been detected under low voltage (less than 3.0V) for 10 continual seconds, a low battery sign can be displayed on LCD, to remind customer to change the battery.

14.1.2 Battery working lifetime

Average working current

- Meter power on $I < 3\mu A$
- Meter power off $15\mu A < I < 30\mu A$

Working lifetime

- The battery can be used at least 10 years.
- When the meter powers off, the lifetime of battery can be at least 2 years.

14.1.3 External battery replacement

- 1) Power off the meter.

Customer should replace battery after powering off the meter. If it is inevitable to replace battery when powering on, please be even more careful for replacement operation to avoid electrical shock accidentally!



WARNING

Before battery replacement, must power off the meter first, otherwise it may threat life. Make sure in replacement process, power grid will not power on by mis-operation.

- 2) Open communication module cover.
- 3) Remove the battery to be replaced.



- 4) Plug in the new battery.



- 5) If the display of meter works, it means new battery installation is correct.
- 6) Close communication module cover.
- 7) Power on the meter.

**NOTE**

To ensure battery replacement will not make any influence to RTC of the meter, please try to finish battery replacement in a short period (within 20s is recommended), or after battery replacement, use PC software or HHU to write RTC of the meter.

14.2 Super capacitor(optional)

A full charged super capacitor can support the meter to run RTC at least 48h when the meter is power off.

15 RTC

The smart meter is able to supports calendar, time and leap year automatic when changing function.

The accuracy is less than 0.5s/day at 23 °C, totally comply with IEC 62054-21

Content of clock and range

- year (2000~2099)
- month (01~12)
- day (01~31)
- week (01~07) from Monday to Sunday
- hour (00~23)
- minute (00~59)
- second (00~59)

It is not suggested to synchronize clock around 0:00 o'clock to avoid the repetition or missing of frozen data.

15.1 DST

DST (Daylight Saving Time): DST is a system which regulates the local time for energy conservation the unified time is called "DST". Generally, during the summer time, people will set the clock one hour ahead, in order to make people get up and go to bed earlier, reduce the amount of lighting, and make full use of light resources and save lighting electricity.

15.1.1 DST configurable

The start time, end time can be configured hour-based.

The switching interval can be configured.

For example, the DST starts on 2:00, the last Sunday of March, when the meter enters DST, it will switch from 2:00 to 3:00.

The DST ends on 3:00, the last Sunday of October, when the meter exits DST, it will switch from 3:00 to 2:00.

15.1.2 Restrictive conditions

DST time span cannot exceed 10 months for a single DST.

DST time span cannot be less than 1 day for a single DST.

15.2 TOU

- 4 tariffs(default), 8 tariff(optional)
- maximum 50 holidays
- maximum 6 season tables
- Maximum of 8 weekly time tables
- Maximally 8 daily timetables

Holidays can be divided into two types: special yearly holiday and public yearly holiday. Special yearly holidays work only in specific years, while public yearly holidays work through the current and future years.

Maximally 6 season tables can be configured for each year, and each season corresponds to a weekly time table.

Maximally 8 weekly time tables can be configured, and each weekly time table supports separate configuration of daily time table from Monday to Sunday.

HEXING TECHNOLOGIES EUROPE S.R.L.

Sat Giarmata, Comuna Giarmata, DJ 691 KM 8 + 775 M DREAPTA, Judet Timis, Romania.
Phone: +40 742058188 Email: Europe@hxgroup.com

Maximally 8 daily time tables can be configured, and each daily time table supports configuration of up to 8 time periods. Configuration of crossing zero is also available.

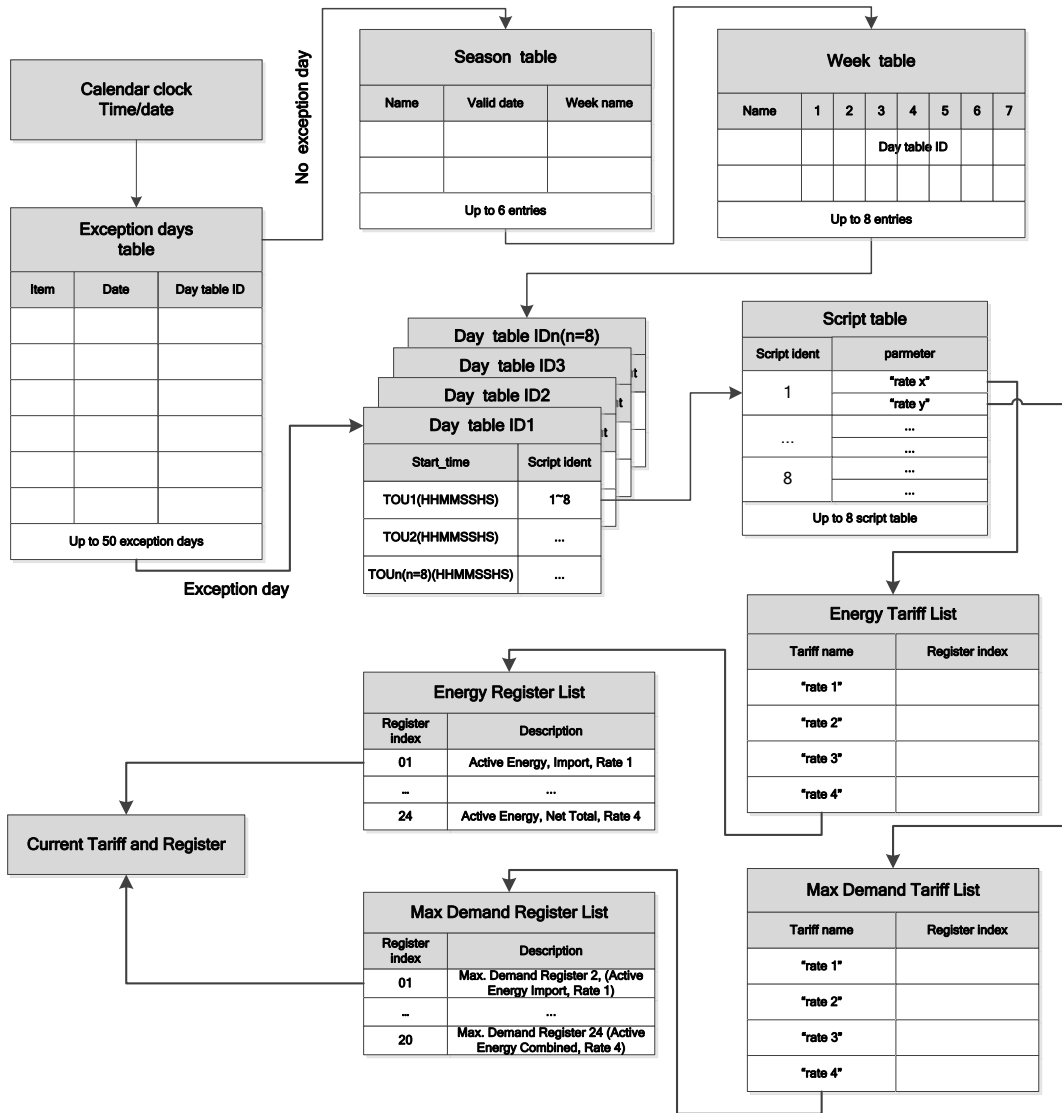

Flow chart of TOU tariff table judgment process

15.2.1 Active and passive tariff

Support active and passive tariff

The way to activate Passive tariff:

- Set passive tariff active time and when meter clock goes across the set time, the passive tariff will be activated and overwrite the old active tariff
- Set clock into past time (earlier than meter now time), the passive tariff will activate immediately.

16 LED Indication

16.1 Active LED indication

When LED flashes, it means active energy consumption. When meter powers on, the LED is available to configure under the status always on or off, default is always off.

16.2 Reactive LED indication

When LED flash, it means reactive energy consumption. When meter power on, the LED is available to configure under the status always on or off, default is always off.

16.3 Alarm LED indication

When tamper events occur, alarm LED will light on all the time. When tamper events are cleared, alarm LED will light off.

17 Communication interface

The customer can choose one or more communication interface according to the requirement.

17.1 Optical communication

- Comply with IEC62056-21 optical communication physical interface standard.

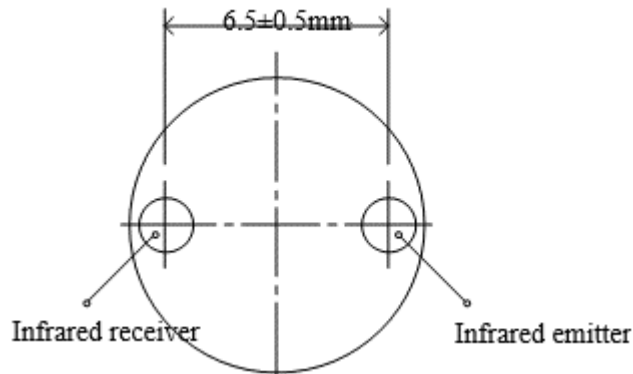

Front view of optical port

- Signal wavelengths: 900nm~1000nm(infrared).

A magnetic plate is installed inside the meter cover, to ensure the optical head can be firmly fixed on the meter.



Optical port

Communication standards: IEC62056-21 E mode or DLMS HDLC, default is E mode. 300bps standby, 9600 bps for communication(4800~19200bps configurable)

17.2 RS485 interface

- Communication protocol: DLMS HDLC
- Baud rate: 600~9600 bps (configurable), default is 9600bps. Data bits is 8, none parity

17.3 M-Bus interface(Optional)

- Communication protocol: EN 13757
- Communication distance: At least 200m (cable is 0.5 mm^2)
- Baud rate: 2400 bps, data bits is 8, even parity

17.4 P1 port interface(Optional)

- Communication standards: DSMR P1 5.0.2

HEXING TECHNOLOGIES EUROPE S.R.L.

Sat Giarmata, Comuna Giarmata, DJ 691 KM 8 + 775 M DREAPTA, Judet Timis, Romania.
Phone: +40 742058188 Email: Europe@hxgroup.com

17.5 GPRS/4G communication(Option)

- Communication standards: DLMS/COSEM, TCP/IP
- GPRS/4G module supports client mode and server mode.
- GPRS/4G module online mode:
 - ✓ **Always online mode:** module will be online all time
 - ✓ **Time period online mode:** module will be online at preset period
 - ✓ **Passive activation online mode:** module will be online just under SMS or call active message
 - ✓ **On demand online mode:** module supports both time period online and passive activation mode

17.6 G3-PLC communication(Optional)

- Communication standards: DLMS/COSEM
- Support plug and play G3-PLC module.

17.7 Prime-PLC communication(Optional)

- Communication standards: DLMS/COSEM, Prime 1.4 standard.
- Support both integrated Prime design and plug and play Prime module

18 Auxiliary interface(Optional)

18.1 Auxiliary port diagram(Optional)

All of auxiliary port are optional, and some port's functions are reused, selected according to the technical requirements with customer.

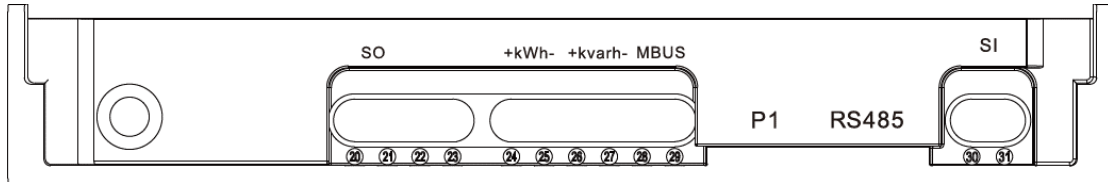

18.2 Auxiliary port function(Optional)

- **20-21: Latch relay or Dry-reed relay or Null**
 Latch relay parameter: Maximum current 10A, Maximum voltage 250VAC/30VDC
 Dry-reed relay parameter: Maximum current 5A, Maximum voltage 250VAC/30VDC
- **22-23: Dry-reed relay or Null**
 Dry-reed relay parameter: Maximum current 5A, Maximum voltage 250VAC/30VDC
- **24-25: Active Energy pulse output or Null**
 Active Energy pulse output parameter: Pulse-Width>30ms
- **26-27: Reactive Energy pulse output or Null**
 Reactive Energy pulse output parameter: Pulse-Width>30ms
- **28-29: M-bus or Null**
- **PORT1: P1 or Null**
- **PORT2: RS485 or RS485 with 12V voltage output or Null**
- **30-31: RS485 or SI (Signal input) or Null**
 Signal input parameter: Passive pulse input, usually used to opening meter box detection.

19 Client management

The meter shall fully support DLMS Security as described in the 8th DLMS/COSEM Green Book and it can transmit the data with/without encryption and authentication.

Several authentication mechanisms are used to authenticate communication entities during AA establishment. Data transportation security is based on a role-based security. Each role has its own access privileges. And all these authentication and encryption algorithms are limited to security policy. Here as following is the list with all the roles, their privileges and authentication mechanism:

Role	Client ID	Privileges	Description
Public client	16	Read limited meter information, like the meter serial number, clock, etc.	Accessible via remote communication and local interface without any security
Reading client (Technician)	2	Read meter data and parameters	Established with authentication HLS (LLS backup) Data transmission with none security, or authentication and encryption
Management client	1	Read meter data, configure meter parameters and control meter	Established with authentication HLS (LLS backup) Data transmission with none security, or authentication and encryption
Pre-established client	102	Receive broadcast commands, and push data	Accessible only via remote communication Always Established Data transmission with none security, or authentication and encryption

20 Overall dimensions and installation

20.1 Meter Connection

Please follow the instruction to arrange the wire connection:

- a) Use copper cable to connect terminal block.
- b) Screw out the wire-fasten screw so that the connection wires can be inserted into.
- c) Remove the plastic cover of the connection wire and make sure that the exposed wire is long enough, the recommended length is no less than 22cm.
- d) Tighten the screws to fix the connection wires.
- e) Check whether the connection is tight or not.



NOTE

The screws in the terminal block should be screwed down tightly to avoid burnt.

20.1.1 Connection Diagram:

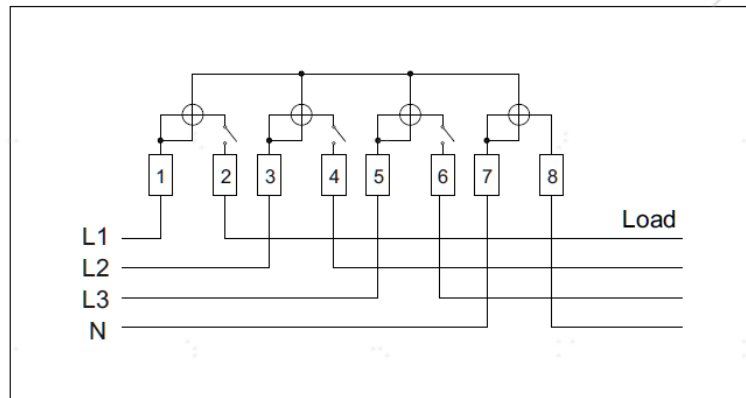

3P4W Asymmetric Connection

20.1.2 Auxiliary terminal wiring diagram

- 20-21: Screw tighten terminals, Magnetic hold auxiliary relay/non-magnetic hold auxiliary relay /null
- 22-23: Screw tighten terminals, non-magnetic hold auxiliary relay / null
- 24-25: Screw tighten terminals, Active Energy pulse output /null
- 26-27: Screw tighten terminals, Reactive energy pulse output/ null
- 28-29: Screw tighten terminals, MBUS/ null
- PORT1: RJ12 terminal, P1/ null
- PORT2: RJ45 terminal, RS485/ RS485(+12V) / null
- 30-31: Screw tighten terminals, RS485/ SI/ null



- **RS485 wiring diagram**
 - Terminal 30: RS485-A
 - Terminal 31: RS485-B
- **P1 port wiring diagram(Option)**

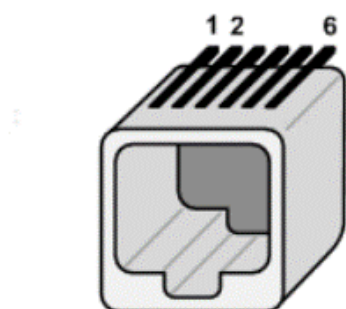

Metering System
RJ12 female socket

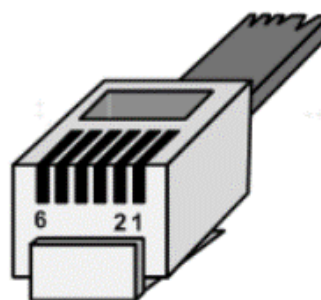

OSM
RJ12 male connector

Pin #	Signal name	Description	Remark
1	+5V	+5V power supply	Power supply line
2	Data Request	Data Request	Input
3	Data GND	Data ground	
4	n.c.	Not connected	
5	Data	Data line	Output. Open collector
6	Power GND	Power ground	Power supply line

20.2 Meter Dimension

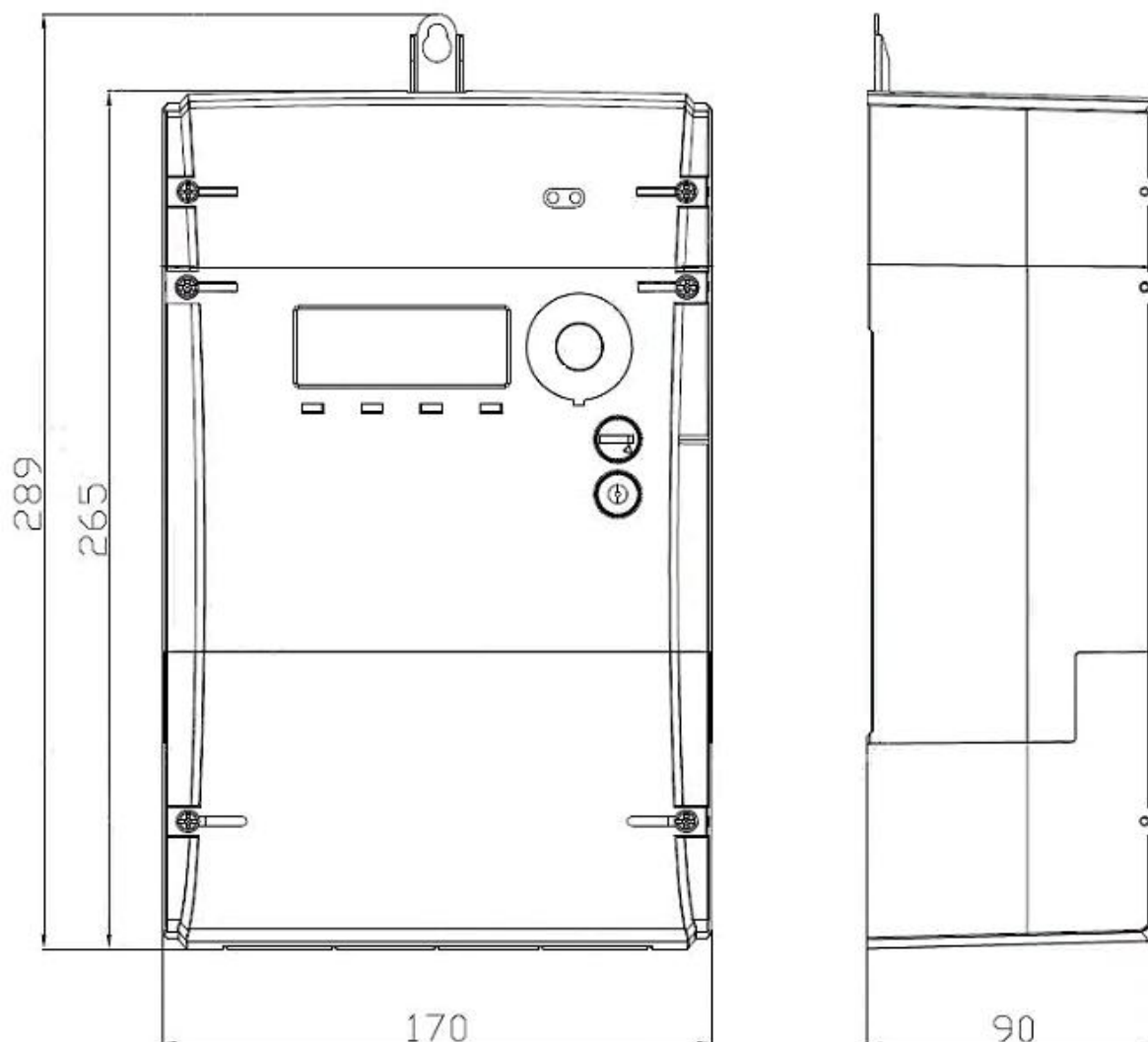

Dimension of smart meter (long terminal cover 31mm)

- Length—289mm (DIN with metal hanging), 265mm (BS)
- Width—170mm
- Height—90mm
- Terminal space—31mm



NOTE

The terminal space of terminal cover is able to change according to the customer requirement. The default terminal space value is 31mm.

The meter hanger is optional according to the customer requirement.

20.3 Installation dimension drawing

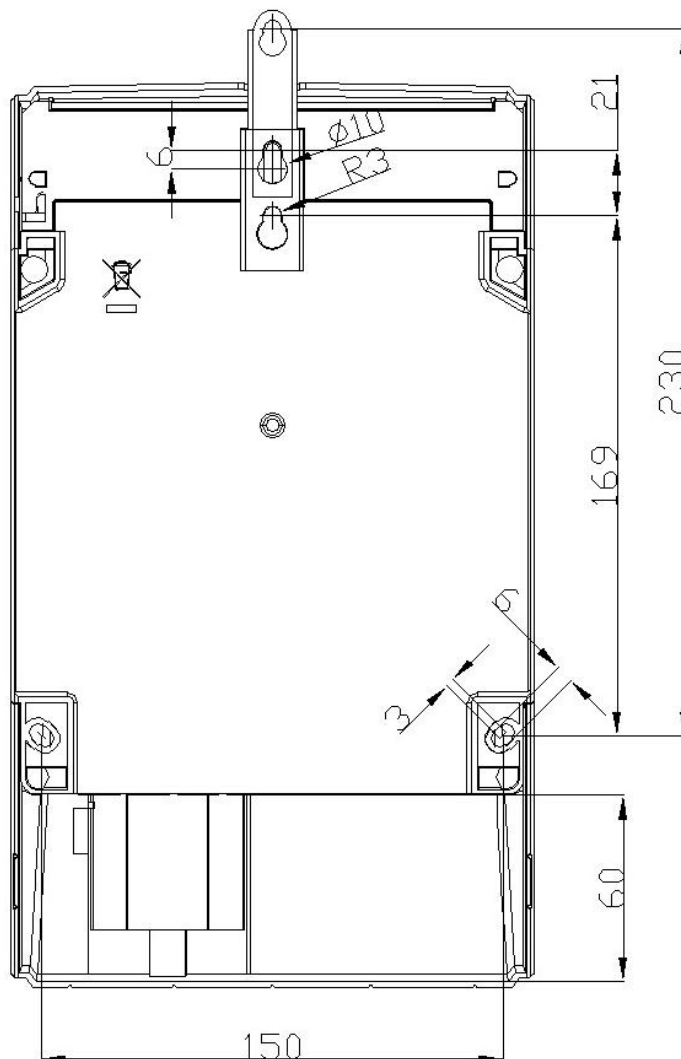

Installation Dimension

20.4 Terminal drawing

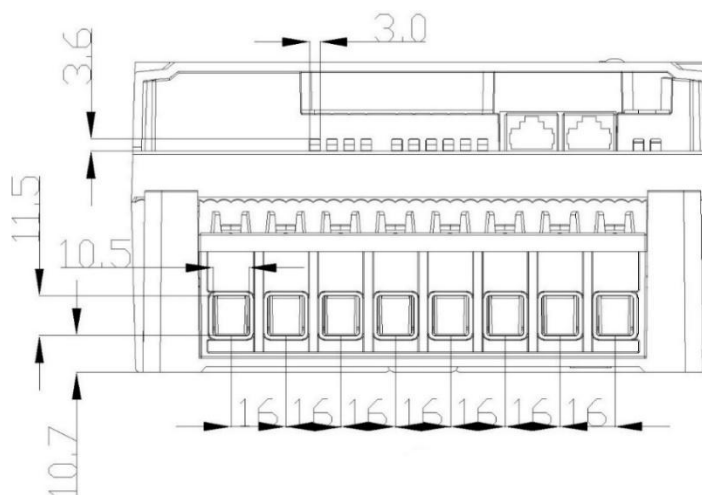

Dimension of Terminal Block



HEXING TECHNOLOGIES EUROPE S.R.L.

Sat Giarmata, Comuna Giarmata, DJ 691 KM 8 + 775 M DREAPTA, Judet Timis, Romania.

Phone: +40 742058188 Email: Europe@hxgroup.com

21 Installation and un-installation

21.1 Installation tools

Cross screwdriver	
Electric drill	
Wire stripper	
Lead sealing pliers	
Hair springs	
Screw	

21.2 Preparation before installation

- The meter should be installed in ventilated and dry place to ensure the meter's safety and reliability. In the dirty or risky area, the meter should be installed in a protection box.
- There should be protective device at the front end of the meter to ensure that the maximum current of supply side not more than meter's maximum current, if the direct connected meter with

SGS also not more than contactor's maximum current according to UC category.

- Meter should be fixed on a firm, fire-resistant and stable support.
- Before installation, please check if the meter has been damaged during the transportation (damage of meter cover, hanger, seal, and LCD display, etc.)
- As the internal part of the electrical meter is composed by the delicate electronic components, the meter should be carefully protected during the installation in order to avoid any damage.

WARNING

Make sure that the power is cut off before the meter installation, otherwise it will cause a threat to life. The fuse should be disconnected and put it in a safe place to avoid the accidental power-on.

21.3 Installation procedure

1. Select the proper position according to the meter dimensions, and indicate fixing points of the meter on the installation panel.
2. Drill down holes on previously marked positions. (make sure that there's no cable behind before punching, avoid ruining the cable and threatening personal safety)

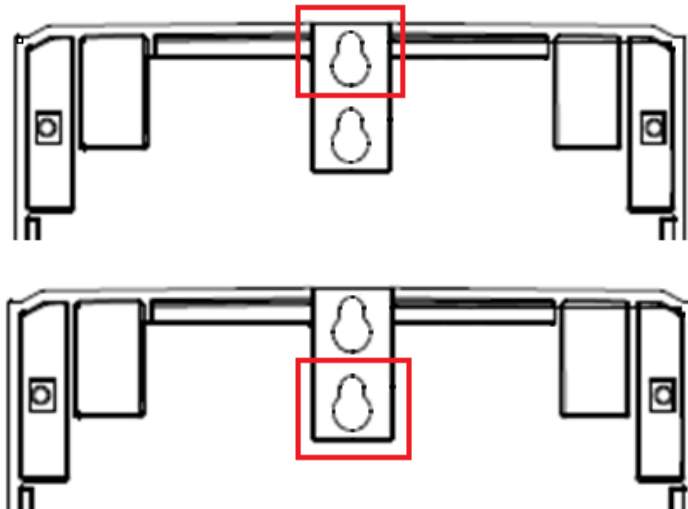

3. Open the meter terminal cover, and adjust the height of hanger.
4. Using the vertical installation method, the meter hangs on the hanger screw, and fixed on the bottom by two screws. Need to make sure that the 3 screws are completely banned, and the meter is installed firmly, without shaking.

NOTE

To ensure the installation stability, the diameter of hanger screw must be longer than 11mm, and the diameter of bottom fixed screws must be wider than 7mm.

5. Cut the cable to the required length and use the wire stripper to uncover the cable. The recommended bare metal length after stripping is at least 20mm for this series of products.

WARNING

We insist on the recommended length of the stripped wire to make sure that the bare metal part is long enough and can be fixed by two connection screws at the same time. However the bare part should not exceed the terminal box wiring

holes, ensure the safety and insulation effect.

- When using a small sectional cable, such as 4mm squared, the cable must be placed in the medium to ensure that the screw is well tightened without deviation.

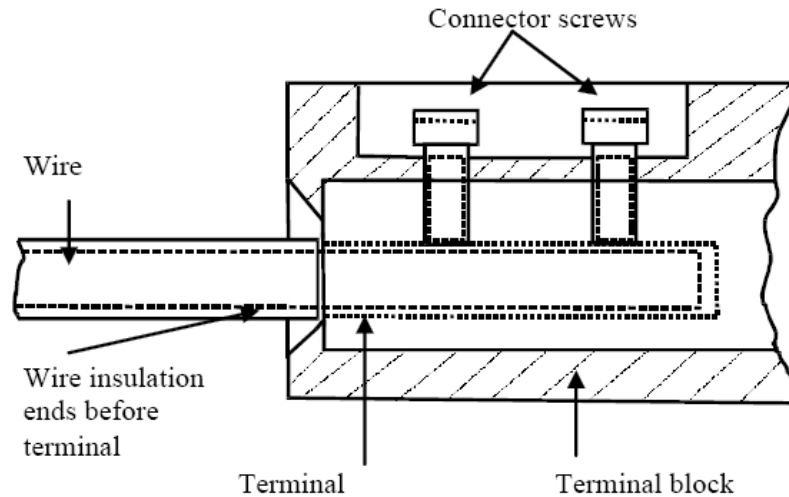

- The cables should be connected correctly according to the wiring diagram and the terminals should be tightened during the installation in order to avoid any damage caused by bad connection.

**NOTE**

The bad fixing of connection screws will lead to the raise of resistance, which can lead to electrical energy loss and heating of terminals. The heating of component is risky. Besides, 1mΩ contact resistance in a circuit of 80A will result in 6.4 W power losses.

- The cables should be connected correctly according to the definition of the auxiliary terminal (such as pulse output, signal input or RS485 communication).

**WARNING**

Please be careful and don't connect the auxiliary terminal with the voltage or current line by mistake to avoid damage to meter.

- Check connecting wire carefully and avoid any error (such as the reverse wiring for the incoming and outgoing lines, the wrong connection of live and neutral, the bad fixing of screws).

**NOTE**

To ensure the correct wiring, it is recommended to use the appropriate testing tools (such as multi-meters) for input/output test.

- Close the terminal cover, and sealed it.

**NOTE**

Please make sure that the terminal cover is closed tightly, otherwise it will cause the meter relay cut off due to terminal cover open.

21.4 Commissioning test after installation

- Switch on the breaker
- Check the meter display, if there is any malfunction indication, phase inverse, cover open, or strong magnetic field, no current indicator.
- Press button to display voltage value, check the voltage twice.
- Check the relay is on the right position (if the symbol '  ' is shown on the LCD).

**CAUTION**

After the commissioning test, the meter will exit the storage mode, the service life of the battery will be affected if kept a long time interruption of supply.

Please keep that the installation environment has enough space or ventilation, exceeding the operating temperature of the meter may cause error changes.

21.5 Remove

1. Switch off the breaker and power off the meter.

**WARNING**

Make sure that the power is cut off before the meter un-installation, otherwise it will cause a threat to life. The fuse should be disconnected and put it in a safe place to avoid the accidental power-on.

2. Cut off the terminal cover seal, and remove the terminal cover.
3. Use the voltage test equipment (such as multi-meter) to test meter connecting wire and confirm power-off before go to the next operation.
4. Use the appropriate screwdriver to unscrew the meter auxiliary terminal screws and remove the connecting wires.
5. Use the appropriate screwdriver to unscrew the current connection screws and remove the connecting wires.
6. Use the appropriate screwdriver to unscrew the meter fixing screws.
7. Remove the meter.

**CAUTION**

The meter un-installation should be done according to the above -mentioned steps. Be attention to prevent meter from dropping down, which will cause injuries and damage to the meter itself.

8. If necessary, please replace a new meter.

**WARNING**

If a new meter cannot be installed at the moment, please envelop the voltage and current connection cables in insulating material and avoid exposing any

bare metal part, otherwise it will pose a threat to life.

22 Service

22.1 Fault Operation

If the LCD cannot display correctly, or data communication does not work, please check as follows:

1. Whether the environment temperature is over the limit working temperature range of the meter
2. Whether the optical communication interface or LCD display window is clean (no scratches, no paint, no fog, or any other kinds of pollution)

If it's not the above-mentioned reasons which leads to failure, meters should be unloaded and sent to Hexing service center.

22.2 Meter Repair

If the meter repair is necessary, please operate in accordance with the following process:

1. If the METER has been installed, then uninstall the METER (refer to section 21 "install and uninstall"), and reinstall another METER.
2. Describe the fault phenomenon as much as possible (if you can, please provide with METER fault code), the name, phone number of the responsible person for the follow-up maintenance. Please indicate the serial number and complete METER model (METER model can be obtained from the METER nameplate)
3. Package the METER, ensure the METER will not be damaged during the transport. Try to use the original package. Don't put in a METER with missing part
4. Send the electric METER to a certified Hexing service center

23 Maintenance

There is no need to change the METER within the life cycle. METER maintenance can be executed based on local regulations. Recommended every 5~10 years.

23.1 Clean

Use dry cloth to clean the surface of the METER and wipe the stains and insects.



WARNING

Warning: Flowing water and high-pressure water equipment is not allowed to clean the METER, which may lead to short circuit.

23.2 Error and function check

The following process can be performed to recognize error and check function

1. Insert the METER to the corresponding terminal of error test bench. (electric METER wiring hole number detailed in chapter 19.1 "Meter Connection"), tighten the connection screws (maximum torque is 3Nm)
2. Put the pulse testing part of the error testing bench align to the LED on the METER. (Actual auxiliary terminal definition can be found on installation manual or on the wiring diagram on the nameplate.)
3. Start the error test bench. Put on rate voltage but no current. Confirm no current indicator display on LED. Check whether the electric METER is displayed correctly (trouble-free code instructions).
4. After the METER is power on, set the METER to test mode through communication. The test mode is with the highest level of security. Both communication key and administrator password are needed to enter the test mode.



NOTE

Attention: In order to not affect the actual accumulated power when doing the test, each time METER is off from the electricity, the METER need to set into the test mode again.

5. Start the error testing bench
6. Execute relay control operation through PC software (if the relay is applied), check whether the relay is working properly.
7. Take away the METER from the test bench after test finished.

23.3 Reinstall

In order to avoid the change of asset management, it's recommended to reinstall the METER in the former position.

The installation process detailed refer to chapter 21 "install and uninstall".

24 Scrap Processing

This chapter describes the right method of meter scrap processing.

Comply with the ISO 14001 environmental certification specification, the components of the meter is separable to maximum extent, therefore you can send the corresponding abandoned to recycling station after disassembled.



NOTE

Attention: meter scrap processing should comply with local waste and environmental protection laws and regulations.

Meter can be disassembled into different parts of the recommended waste treatment methods are as follows:

Parts	Recommend scrap processing method
PCB board	Electronic waste, scrap according to local regulations
Metal parts, including iron part of optical communication, terminal connection copper bar, internal current cables etc.	Provided to the metal material recycling
Plastic	Recycle bin for plastic materials, otherwise can burn

25 Transportation and Storage

The meters should be placed on pallet and the height should not exceed 5 layers. The storage condition should be clean, with an environmental temperature of between -40°C and +70°C, relative humidity of less than 95% and with an absence of rusty matter in the air.

26 Parameters

Electrical	
Reference Voltage	3P4W: 3×220/380-3×240/415V
Basic current	5A,10A
Maximum current	60A,80A,100A
Utilization category for relay(SCS)	UC3
Operating voltage of relay(SCS)	230V or equal to meter reference voltage
Maximum operating current of relay(SCS)	100A
Starting current	≤0.4%I _b (active) ≤0.5%I _b (reactive)
Frequency	(50±5%)Hz
Consumption in current circuit	≤2VA
Consumption in voltage circuit	≤2W/10VA without communication ≤5W/25VA with communication
Battery life	15years
Data retention	>15years
Meter life	15years
Impulse constant	1000imp/kWh 1000imp/kvarh

Auxiliary output relay	
Maximum operating voltage	250V AC
Maximum operating current	5A
Type of the contact	Normally open
Contact impedance	50 mΩ
Withstand voltage across open contacts	1000V AC (50/60 Hz 1min)
Number of operating cycles	100,000

Note: Auxiliary output relays are optional features if applicable

External influence	
Protection	IP54(indoor)
Material for meter case compliance	ISO 75
Operating temperature	-40°C~+70°C
Storage temperature	-40°C~+70°C
Relative humidity	≤95% Non-Condensing
Atmospheric pressure	63kPa-106kPa
Altitude	0-2000 meter
Pollution degree	2

HEXING TECHNOLOGIES EUROPE S.R.L.

Sat Giarmata, Comuna Giarmata, DJ 691 KM 8 + 775 M DREAPTA, Judet Timis, Romania.
Phone: +40 742058188 Email: Europe@hxgroup.com

Mechanical Environment	M1, M2
Electromagnetic Environment	E1, E2

Electromagnetic compliance

Fast transient burst	4kV
Surge voltage	4kV

Electrical insulation

Protective class	II
Impulse voltage	6kV
AC voltage	4kV

Accuracy

Class (IEC) active	1
Class (EN) active	B
Class (IEC) reactive	2
Standard Compliance	IEC62053-21:2020 IEC62053-23:2020 EN IEC 62052-11: 2021 +A11:2022 EN50470-3:2020

Mechanical parameters

Connection type	Direct connection
Network type	3P4W
Terminal configuration	L1L1L2L2L3L3NN (3P4W)
Weight of Meter	2.28 kg
Dimension(H x W x D)	Long terminal cover: 265mm×170mm×90mm(BS)
Mounting	Front projection mounting Location: Meter box, Wall or Cabinet
Sealing	Sealing provisions for terminal with sealing screw cover
Terminal hole diameter	9.5mm
Rang of wire diameter	4mm ² -35mm ²
Type of wire	Multi-unit copper
Recommend wire diameter	Maximum current 60A≥10 mm ² Maximum current 80A≥16 mm ² Maximum current 100A≥25 mm ²
Terminal cover	Long terminal cover
Meter Cover material	PC+10%GF
Meter Base material	PC+10%GF
Terminal Cover material	PC

HEXING TECHNOLOGIES EUROPE S.R.L.

Sat Giarmata, Comuna Giarmata, DJ 691 KM 8 + 775 M DREAPTA, Judet Timis, Romania.
Phone: +40 742058188 Email: Europe@hxgroup.com

Display parameters

Default display range	0~999999.99 kWh
Display mode	LCD

Annex A Communication and Display OBIS

Display items	Display OBIS code	Display format
Energy		
Active energy import (+A)	1.8.0	xxxxxxx kWh
Active energy import (+A) rate X	1.8.X	xxxxxxx kWh
Active energy export (-A)	2.8.0	xxxxxxx kWh
Active energy export (-A) rate X	2.8.X	xxxxxxx kWh
Reactive energy import (+R)	3.8.0	xxxxxxx kWh
Reactive energy import (+R) rate X	3.8.X	xxxxxxx kWh
Reactive energy export (-R)	4.8.0	xxxxxxx kVAh
Reactive energy export (-R) rate X	4.8.X	xxxxxxx kVAh
Reactive energy of QI	5.8.0	xxxxxxx kVAh
Reactive energy of QI rate X	5.8.X	xxxxxxx kVAh
Reactive energy of QII	6.8.0	xxxxxxx kVAh
Reactive energy of QII rate X	6.8.X	xxxxxxx kVAh
Reactive energy of QIII	7.8.0	xxxxxxx kVAh
Reactive energy of QIII rate X	7.8.X	xxxxxxx kVAh
Reactive energy of QIV	8.8.0	xxxxxxx kVAh
Reactive energy of QIV rate X	8.8.X	xxxxxxx kVAh
Apparent energy import	9.8.0	xxxxxxx kVAh
Apparent energy import rate X	9.8.X	xxxxxxx kVAh
Apparent energy export	10.8.0	xxxxxxx kVAh
Apparent energy export rate X	10.8.X	xxxxxxx kVAh
Combined active energy	15.8.0	xxxxxxx kWh
Combined active energy rate X	15.8.X	xxxxxxx kWh
Net active energy	16.8.0	xxxxxxx kWh
Net active energy rate X	16.8.X	xxxxxxx kWh
Instantaneous		
Instantaneous voltage on phase A	32.7.0	xxx.xx V
Instantaneous current on phase A	31.7.0	xxx.xx A
Instantaneous voltage on phase B	52.7.0	xxx.xx V
Instantaneous current on phase B	51.7.0	xxx.xx A
Instantaneous voltage on phase C	72.7.0	xxx.xx V
Instantaneous current on phase C	71.7.0	xxx.xx A
Instantaneous current on neutral	91.7.0	xxx.xx A
Instantaneous net frequency	14.7.0	xx.xx Hz
Instantaneous active import power (+A)	1.7.0	xx.xx kW

Display items	Display OBIS code	Display format
Instantaneous active export power (-A)	2.7.0	xx.xx kW
Instantaneous reactive import power (+R)	3.7.0	xx.xx kVAr
Instantaneous reactive export power (-R)	4.7.0	xx.xx kVAr
Instantaneous active import power (+A) in L1	21.7.0	xx.xx kW
Instantaneous active export power (-A) in L1	22.7.0	xx.xx kW
Instantaneous reactive import power (+R) in L1	23.7.0	xx.xx kVAr
Instantaneous reactive export power (-R) in L1	24.7.0	xx.xx kVAr
Instantaneous active import power (+A) in L2	41.7.0	xx.xx kW
Instantaneous active export power (-A) in L2	42.7.0	xx.xx kW
Instantaneous reactive import power (+R) in L2	43.7.0	xx.xx kVAr
Instantaneous reactive export power (-R) in L2	44.7.0	xx.xx kVAr
Instantaneous active import power (+A) in L3	61.7.0	xx.xx kW
Instantaneous active export power (-A) in L3	62.7.0	xx.xx kW
Instantaneous reactive import power (+R) in L3	63.7.0	xx.xx kVAr
Instantaneous reactive export power (-R) in L3	64.7.0	xx.xx kVAr
Instantaneous power factor (PF)	13.7.0	x.xxx
Instantaneous power factor (PF) in L1	33.7.0	x.xxx
Instantaneous power factor (PF) in L2	53.7.0	x.xxx
Instantaneous power factor (PF) in L3	73.7.0	x.xxx
Demand		
Import active MD	1.6.0	xxxxx.xxx kW
Import active MD occurrence date	1.6.0	dd-mm-yy
Import active MD occurrence time	1.6.0	hh:mm:ss
Import active MD rate X	1.6.X	xxxxx.xxx kW
Import active MD rate X occurrence date	1.6.X	dd-mm-yy
Import active MD rate X occurrence time	1.6.X	hh:mm:ss
Export active M.D	2.6.0	xxxxx.xxx kW
Export active MD occurrence date	2.6.0	dd-mm-yy
Export active MD occurrence time	2.6.0	hh:mm:ss
Export active MD rate X	2.6.X	xxxxx.xxx kW
Export active MD rate X occurrence date	2.6.X	dd-mm-yy
Export active MD rate X occurrence time	2.6.X	hh:mm:ss
Import reactive MD	3.6.0	xxxxx.xxx kVAr
Import reactive MD occurrence date	3.6.0	dd-mm-yy
Import reactive MD occurrence time	3.6.0	hh:mm:ss
Import reactive MD	3.6.X	xxxxx.xxx kVAr
Import reactive MD rate X occurrence date	3.6.X	dd-mm-yy

HEXING TECHNOLOGIES EUROPE S.R.L.

Sat Giarmata, Comuna Giarmata, DJ 691 KM 8 + 775 M DREAPTA, Judet Timis, Romania.
 Phone: +40 742058188 Email: Europe@hxgroup.com

Display items	Display OBIS code	Display format
Import reactive MD rate X occurrence time	3.6.X	hh:mm:ss
Export reactive MD	4.6.0	xxxxx.xxx kVAr
Export reactive MD occurrence date	4.6.0	dd-mm-yy
Export reactive MD occurrence time	4.6.0	hh:mm:ss
Export reactive MD	4.6.X	xxxxx.xxx kVAr
Export reactive MD rate X occurrence date	4.6.X	dd-mm-yy
Export reactive MD rate X occurrence time	4.6.X	hh:mm:ss
Import apparent MD	3.6.0	xxxxx.xxx kVAr
Export apparent MD rate X occurrence date	4.6.X	dd-mm-yy
Export apparent MD rate X occurrence time	4.6.X	hh:mm:ss
Combined active MD	15.6.0	xxxxx.xxx kW
Combined active MD occurrence date	15.6.0	dd-mm-yy
Combined active MD occurrence time	15.6.0	hh:mm:ss
Combined active MD rate X	15.6.X	xxxxx.xxx kW
Combined active MD rate X occurrence date	15.6.X	dd-mm-yy
Combined active MD rate X occurrence time	15.6.X	hh:mm:ss
Others		
Local time	0.9.1	hh:mm:ss
Local date	0.9.2	dd-mm-yy
Error register	F.F.0	xxxxxxxx
Meter serial number	C.1.0	xxxxxxxx
Number of power failures on all phase	C.7.0	xxxxxxx
Number of long power failures on all phase	C.7.5	xxxxxxx
Reason of disconnected	146.A.18	
Calendar name	13.0.0	xxxxxxxx
Limiter 1 threshold	17.0.0	xxxxx.xxx kW
Display all on LCD	C.2.221	
Battery voltage	C.6.3	

Annex B Demand content OBIS list

Description	OBIS
Active import demand	1.0.1.4.0.255
Reactive import demand	1.0.2.4.0.255
Active export demand	1.0.3.4.0.255
Reactive export demand	1.0.4.4.0.255
Reactive demand in QI	1.0.5.4.0.255
Reactive demand in QII	1.0.6.4.0.255
Reactive demand in QIII	1.0.7.4.0.255
Reactive demand in QIV	1.0.8.4.0.255
Import apparent demand	1.0.9.4.0.255
Export apparent demand	1.0.10.4.0.255
Active demand (QI+QIV + QII+QIII)	1.0.15.4.0.255
Active import MD total and per tariff	1.0.1.6.x.255 (x=0~4)
Active export MD total and per tariff	1.0.2.6.x.255 (x=0~4)
Reactive import MD total and per tariff	1.0.3.6.x.255 (x=0~4)
Reactive export MD total and per tariff	1.0.4.6.x.255 (x=0~4)
Reactive MD total and per tariff in QI	1.0.5.6.x.255 (x=0~4)
Reactive MD total and per tariff in QII	1.0.6.6.x.255 (x=0~4)
Reactive MD total and per tariff in QIII	1.0.7.6.x.255 (x=0~4)
Reactive MD total and per tariff in QIV	1.0.8.6.x.255 (x=0~4)
Import apparent MD total and per tariff	1.0.9.6.x.255 (x=0~4)
Export apparent MD total and per tariff	1.0.10.6.x.255 (x=0~4)
Active accumulated MD (QI+QIV + QII+QIII)	1.0.15.6.x.255 (x=0~4)



HEXING TECHNOLOGIES EUROPE S.R.L.

Sat Giarmata, Comuna Giarmata,
DJ 691 KM 8 + 775 M DREAPTA,
Judet Timis,
Romania.
Phone: +40 742058188
Email: Europe@hxgroup.com
Web: www.hexing.ro