



Bakery & Food Processing Equipment
Professional Kitchen Equipment
Commercial Refrigeration Equipment
Stainless Steel Fabrication

LINK RICH



LinkRich

Linkrich Machinery Development Co., Ltd

105-106, Block 15th, Tian'an Science & Technology
Innovation Center, No.555, Panyu Avenue North, Panyu,
Guangzhou, China

Tel: +86 20 87601850 87603075
Email: info@chinalinkrich.com
www.chinalinkrich.com

2023

www.chinalinkrich.com

ABOUT US

LINKRICH Machinery Group. Established in 2001, we are committed to the improvement and further innovation of professional kitchen equipment. With dedication in product manufacturing, semi-product processing, product marketing and merchandise export. LINKRICH has obtained ISO9001: 2008 quality system certification and developed competences in a wide range of world standard quality products, complete service and self-innovation. From mixers to ovens, cooking equipment to refrigeration, LINKRICH is the answer for all your kitchen equipment requirements.

Our Commitment and Principles

A Passion For Professional Equipment

We are passionate about each and every piece of our equipment. Our highly trained technicians are constantly working to develop new and more efficient systems and processes. All our machinery either meet or exceed international standards.

A long-term Approach For Our Products

Each product purchased from LINKRICH comes with a long term commitment. We fully support all our machinery and back that up with warranties on all parts.

Dedication to Self-innovation

We maintain flexibility to be able to adapt to variable conditions and an ever changing environment. Since the launch of LINKRICH, we have been continually developing new products, keeping up with the latest new techniques and trends to remain at the forefront of the industry.

Devotion to Customer Satisfaction

LINKRICH values and respect our customer's needs and strives to exceed customer expectations. We aim to provide complete services in international trade to ensure complete satisfaction and convenience for each and every customer.



BAKERY EQUIPMENT

Food Mixer	2
Accessories	11
Spiral Mixer	12
Power Mixer	20
French Roll Moulder & Bread Moulder Machine	22
Bun Divider & Dough Divider	23
Bun Divider and Roller	24
Dough Sheeter	25
Pizza Dough Roller	26
Bread Slicer & Multifunctional Filling Dispenser	27
Dumpling Machine	28

FOOD PREPARATION

Noodle Machine & Dough Press Machine	29
Fresh Meat Slicer and Cutter	30
Meat Mincer	31
Meat Mincer & Hamburger Patty Press	32
Meatballs Forming Machines	33
Sausage Stuffer	34
Sausage Stuffer & J Bone Saw Machine	35
Bone Saw Machine	36
Five Finger Plastic Strap Metal Mesh Glove	37
Meat Slicer	38
Vegetable Preparation Machine	40
Combination Processor & Cutter Machine	42
Batch Bowl Food Processor	43
Processing Cutter & Ingredient Mixing Machine	45
Commercial Potato Peeler	46
Manual Potato Cutter & Soybean Grinder	47
Vacuum Sealing Machine	48

COMMERCIAL OVEN

Pizza Oven	49
Electric Conveyor Pizza Oven	50
Gas Conveyor Pizza Oven	51
Electric Food Dehydrator & Electric Smoke House	52
Convection Oven	53
Signature Deck Oven	58
Stainless Steel Oven with Proofer	64
Stainless Steel Oven	67
Professional Digital Stainless Steel Oven	68
Rotary Convection Oven	75
Gas Tunnel Furnace	76
Spray Proofer	77
Refrigerated Bread Fermentation & Water Cooling Machine	78
Rotary Rotisseries	79

CATERING EQUIPMENT

Bread Toaster	81
Salamander	82
Waffle Baker & Cone Baker	83
Crepe Maker	84
Hot Dog Steamer and Warmer & Corn Steamers	85
Hot Dog Machine	86
Kebab Slicer	87
Kebab Machine With Cabinet	88
Coffee Urns	89
Hot Water Urns	90
Commercial Contact Grill & Induction Cooker	91

COOKING EQUIPMENT

Commercial Contact Grill	92
Commercial Electric Deep Fryer	93
Commercial Deep Fryer	97
Commercial Gas Standing Deep Fryer	99
Commercial Gas Deep Fryer	100
Pressure Fryer	101
Commercial Donut Machine	102
Grill and Griddle	104
Gas Grill and Griddle & Gyoza Machine	107
Radiant Charbroiler	108
Countertop Cooking Range	109
Combination Cooking Line	116
Gas Burner	122

COOKING EQUIPMENT

Food Holding Cabinet	126
Electric Rice Steamer	128
Gas Rice Steamer	129
Luxury Rice Steamer	130

CATERING EQUIPMENT

Popcorn Machine	131
Cotton Candy Machine	132
Hot Food Display Warmer & LRH Pizza Warmer	133
Food Warmer & Food Display Steamer	134
Countertop Heated Display Warmer	135
Hot Food Display Warmer	136
Food Display Warmer	139
Bulb Food Warmer	140
Potato Chips Worker	141
Oil Filter Cart & Bolating Machine & Wrapping Powder Table	142
Cup Warmer & Dish Dispenser	143
Soup Warming Kettle	144
Electric Bain Marie	145
BV Kitchenware Equipment	149
Buffet Case	151
Glass Washing Machine & Knife Sterilizer	152
Dish Washer	153
Faucet	158
Glass Racks	159

CAFE & BAR EQUIPMENT

Semi Automatic Coffee Maker	162
Coffee Machine	163
Chocolate Dispenser & Chocolate Fountain	164
Commercial Blender	165
Ice Crusher & Ice Shaver & Milk Shake	166
Juice Extractor & Lemon Juicer & Sugar Cane Juicer	167
Orange Juicer	168
Juicer Dispenser	170
Bowl Refrigerated Beverage Dispenser & Ice Cream Machine	173
Commercial Slushy Machine	174
Snow Machine & Flake Ice Maker	175
Bullet Ice Maker	176
Self Contained Solid Ice Maker	177
Self Contained Solid Ice Cube	178
Ice Cream Machine	179

COMMERCIAL REFRIGERATION

Sushi Showcase & Cake Showcase	184
Cake Showcase	185
Square Series Cake Showcase	187
Combination Cake Display	188
Glass Door Chiller and Freezer	189
Glass Door Drink Display	192

KITCHEN REFRIGERATION

Solid Door Working Chillers	194
Solid Door Vegetable Working Chillers	197
Solid Door Pizza Working Chillers	198
Solid Door Chillers	199
Gastronorm Chiller and Freezers	200
Solid Door Chiller and Freezers	202
Glass Door Chillers	205
Blast Freezer	206

COMMERCIAL REFRIGERATION

Chest Freezers	207
Supermarket Showcase	208
Modular Cool Room	212

STAINLESS STEEL FABRICATION

Working Table	214
Assembling Sink Table	220
Stainless Steel Cabinet	224
Kitchen Desk & Mobile Cabinet	225
Stainless Steel Cabinet & Wall Shelf	226
Stainless Steel Shelving System	227
Buffet Trolley & Bench	228
Bar Bench & Steam Frame	229

Food Mixer



Tabletop Food Mixer

Product Description

- Motor power, strength.
- Circuit board professional level frequency conversion technology, the use of long life, the use of stable
- The use of the surface paint process, no discoloration, resistant to washing
- Mixing effect is more uniform
- It is better to beat the eggs and cream.



Specifications

Model	Power (kW)	Voltage (V)	Capacity (L)	Mixing Speed (r/min)	Max Kneading Capacity (kg)	Net Weight (kg)	Dimensions (mm)
LR-FM-5	0.3	220	5	150-1020	0.5-0.7	25	370x230x410
LR-FM-7	0.35	220	7	150-1020	0.5-0.7	26	410x250x425

Tabletop Food Mixer

Product Description

- Oil pressure bar.
- Motor power, strength.
- All parts are 304 material.
- Switches, electrical accessories etc. are imported.
- Circuit board professional level frequency conversion technology, the use of long life, the use of stable
- The use of the surface paint process, no discoloration, resistant to washing
- Hook special design, screw type design, the effect is better.
- Mixing effect is more uniform
- It is better to beat the eggs and cream.



Specifications

Model	Power (kW)	Voltage (V)	Capacity (L)	Mixing Speed (r/min)	Max Kneading Capacity (kg)	Net Weight (kg)	Dimensions (mm)
B8	0.55	220	7.5	130~900	0.6	30	470x255x465

10L Planetary Food Mixer

Product Description

- Great for mixing, beating, whipping batters, cake mixes and the occasional dough or pastry. Thanks to their multitude of functions, they are the best partner for professional cooks.
- Ergonomic style bowl lift, and a removable safety guard make it incredibly easy to remove them for cleaning and maintenance without tools.
- Integrated emergency stop, motor overload protection, cover opening protection and bowl sliding protection ensure the operator's safety.
- The non-welded brushed stainless steel bowl adopts a one-step molding technique which enhances durability.
- Supplied standard with stainless steel safety guard, stainless steel bowl, beater, whip and dough hook for increased utility and functionality.



Specifications

Model	Power (kW)	Voltage (V)	Capacity (L)	Mixing Speed (r/min)	Max Kneading Capacity (kg)	Net Weight (kg)	Dimensions (mm)
B10	0.37	220	10	67/189/362	2	65	450x370x660

15L Planetary Food Mixer

Product Description

- Great for mixing, beating, whipping batters, cake mixes and the occasional dough or pastry. Thanks to their multitude of functions, they are the best partner for professional cooks.
- Ergonomic style bowl lift, and a removable safety guard make it incredibly easy to remove them for cleaning and maintenance without tools.
- Integrated emergency stop, motor overload protection, cover opening protection and bowl sliding protection ensure the operator's safety.
- The non-welded brushed stainless steel bowl adopts a one-step molding technique which enhances durability.
- Supplied standard with stainless steel safety guard, stainless steel bowl, beater, whip and dough hook for increased utility and functionality.



Specifications

Model	Power (kW)	Voltage (V)	Capacity (L)	Mixing Speed (r/min)	Max Kneading Capacity (kg)	Net Weight (kg)	Dimensions (mm)
B15	0.55	220	15	67/189/362	3	90	540x415x740

20L Planetary Food Mixer

Product Description

- Great for mixing, beating, whipping batters, cake mixes and the occasional dough or pastry. Thanks to their multitude of functions, they are the best partner for professional cooks.
- Ergonomic style bowl lift, and a removable safety guard make it incredibly easy to remove them for cleaning and maintenance without tools.
- Integrated emergency stop, motor overload protection, cover opening protection and bowl sliding protection ensure the operator's safety.
- The non-welded brushed stainless steel bowl adopts a one-step molding technique which enhances durability.
- Supplied standard with stainless steel safety guard, stainless steel bowl, beater, whip and dough hook for increased utility and functionality.



Specifications

Model	Power (kW)	Voltage (V)	Capacity (L)	Mixing Speed (r/min)	Max Kneading Capacity (kg)	Net Weight (kg)	Dimensions (mm)
B20C	0.75	220	20	113/168/386	6	80	570x440x770

20L Planetary Food Mixer

Product Description

- Great for mixing, beating, whipping batters, cake mixes and the occasional dough or pastry. Thanks to their multitude of functions, they are the best partner for professional cooks.
- Ergonomic style bowl lift, and a removable safety guard make it incredibly easy to remove them for cleaning and maintenance without tools.
- Integrated emergency stop, motor overload protection, cover opening protection and bowl sliding protection ensure the operator's safety.
- The non-welded brushed stainless steel bowl adopts a one-step molding technique which enhances durability.
- Supplied standard with stainless steel safety guard, stainless steel bowl, beater, whip and dough hook for increased utility and functionality.



Specifications

Model	Power (kW)	Voltage (V)	Capacity (L)	Mixing Speed (r/min)	Max Kneading Capacity (kg)	Net Weight (kg)	Dimensions (mm)
B20	0.75	220	20	113/168/386	6	98	570x440x770

25L Planetary Food Mixer

Product Description

- Great for mixing, beating, whipping batters, cake mixes and the occasional dough or pastry. Thanks to their multitude of functions, they are the best partner for professional cooks.
- Ergonomic style bowl lift, and a removable safety guard make it incredibly easy to remove them for cleaning and maintenance without tools.
- Integrated emergency stop, motor overload protection, cover opening protection and bowl sliding protection ensure the operator's safety.
- The non-welded brushed stainless steel bowl adopts a one-step molding technique which enhances durability.
- Supplied standard with stainless steel safety guard, stainless steel bowl, beater, whip and dough hook for increased utility and functionality.



Specifications

Model	Power (kW)	Voltage (V)	Capacity (L)	Mixing Speed (r/min)	Max Kneading Capacity (kg)	Net Weight (kg)	Dimensions (mm)
B25	1.1	220	25	113/168/386	8	130	580x450x820

30L Planetary Food Mixer

Product Description

- Great for mixing, beating, whipping batters, cake mixes and the occasional dough or pastry. Thanks to their multitude of functions, they are the best partner for professional cooks.
- Ergonomic style bowl lift, and a removable safety guard make it incredibly easy to remove them for cleaning and maintenance without tools.
- Integrated emergency stop, motor overload protection, cover opening protection and bowl sliding protection ensure the operator's safety.
- The non-welded brushed stainless steel bowl adopts a one-step molding technique which enhances durability.
- Supplied standard with stainless steel safety guard, stainless steel bowl, beater, whip and dough hook for increased utility and functionality.



Specifications

Model	Power (kW)	Voltage (V)	Capacity (L)	Mixing Speed (r/min)	Max Kneading Capacity (kg)	Net Weight (kg)	Dimensions (mm)
B30	1.5	220	30	65/102/296	10	203	680x540x1100

40L Planetary Food Mixer

Product Description

- Great for mixing, beating, whipping batters, cake mixes and the occasional dough or pastry. Thanks to their multitude of functions, they are the best partner for professional cooks.
- Ergonomic style bowl lift, and a removable safety guard make it incredibly easy to remove them for cleaning and maintenance without tools.
- Integrated emergency stop, motor overload protection, cover opening protection and bowl sliding protection ensure the operator's safety.
- The non-welded brushed stainless steel bowl adopts a one-step molding technique which enhances durability.
- Supplied standard with stainless steel safety guard, stainless steel bowl, beater, whip and dough hook for increased utility and functionality.



Specifications

Model	Power (kW)	Voltage (V)	Capacity (L)	Mixing Speed (r/min)	Max Kneading Capacity (kg)	Net Weight (kg)	Dimensions (mm)
B40	1.8	220	40	65/102/296	12	210	680x540x1150

60L Planetary Food Mixer

Product Description

- Great for mixing, beating, whipping batters, cake mixes and the occasional dough or pastry. Thanks to their multitude of functions, they are the best partner for professional cooks.
- Ergonomic style bowl lift, and a removable safety guard make it incredibly easy to remove them for cleaning and maintenance without tools.
- Integrated emergency stop, motor overload protection, cover opening protection and bowl sliding protection ensure the operator's safety.
- The non-welded brushed stainless steel bowl adopts a one-step molding technique which enhances durability.
- Supplied standard with stainless steel safety guard, stainless steel bowl, beater, whip and dough hook for increased utility and functionality.



Specifications

Model	Power (kW)	Voltage (V)	Capacity (L)	Mixing Speed (r/min)	Max Kneading Capacity (kg)	Net Weight (kg)	Dimensions (mm)
B60	2.2/2.8	380	60	73/109/143/216	20	490	1030x620x1430

20L Planetary Food Mixer

Product Description

- Great for mixing, beating, whipping batters, cake mixes and the occasional dough or pastry. Thanks to their multitude of functions, they are the best partner for professional cooks.
- Ergonomic style bowl lift, and a removable safety guard make it incredibly easy to remove them for cleaning and maintenance without tools.
- Integrated emergency stop, motor overload protection, cover opening protection and bowl sliding protection ensure the operator's safety.
- The non-welded brushed stainless steel bowl adopts a one-step molding technique which enhances durability.
- Supplied standard with stainless steel safety guard, stainless steel bowl, beater, whip and dough hook for increased utility and functionality.



Specifications

Model	Power (kW)	Voltage (V)	Capacity (L)	Mixing Speed (r/min)	Max Kneading Capacity (kg)	Net Weight (kg)	Dimensions (mm)
M20A	0.9	220	20	113/168/386	6	102	570x440x770

25L Planetary Food Mixer

Product Description

- Great for mixing, beating, whipping batters, cake mixes and the occasional dough or pastry. Thanks to their multitude of functions, they are the best partner for professional cooks.
- Ergonomic style bowl lift, and a removable safety guard make it incredibly easy to remove them for cleaning and maintenance without tools.
- Integrated emergency stop, motor overload protection, cover opening protection and bowl sliding protection ensure the operator's safety.
- The non-welded brushed stainless steel bowl adopts a one-step molding technique which enhances durability.
- Supplied standard with stainless steel safety guard, stainless steel bowl, beater, whip and dough hook for increased utility and functionality.



Specifications

Model	Power (kW)	Voltage (V)	Capacity (L)	Mixing Speed (r/min)	Max Kneading Capacity (kg)	Net Weight (kg)	Dimensions (mm)
M25A	1	220	25	113/168/386	8	130	580x450x820

30L Planetary Food Mixer

Product Description

- Great for mixing, beating, whipping batters, cake mixes and the occasional dough or pastry. Thanks to their multitude of functions, they are the best partner for professional cooks.
- Ergonomic style bowl lift, and a removable safety guard make it incredibly easy to remove them for cleaning and maintenance without tools.
- Integrated emergency stop, motor overload protection, cover opening protection and bowl sliding protection ensure the operator's safety.
- The non-welded brushed stainless steel bowl adopts a one-step molding technique which enhances durability.
- Supplied standard with stainless steel safety guard, stainless steel bowl, beater, whip and dough hook for increased utility and functionality.



Specifications

Model	Power (kW)	Voltage (V)	Capacity (L)	Mixing Speed (r/min)	Max Kneading Capacity (kg)	Net Weight (kg)	Dimensions (mm)
M30A	1.5	220	30	65/102/296	10	203	680x540x1100

40L Planetary Food Mixer

Product Description

- Great for mixing, beating, whipping batters, cake mixes and the occasional dough or pastry. Thanks to their multitude of functions, they are the best partner for professional cooks.
- Ergonomic style bowl lift, and a removable safety guard make it incredibly easy to remove them for cleaning and maintenance without tools.
- Integrated emergency stop, motor overload protection, cover opening protection and bowl sliding protection ensure the operator's safety.
- The non-welded brushed stainless steel bowl adopts a one-step molding technique which enhances durability.
- Supplied standard with stainless steel safety guard, stainless steel bowl, beater, whip and dough hook for increased utility and functionality.



Specifications

Model	Power (kW)	Voltage (V)	Capacity (L)	Mixing Speed (r/min)	Max Kneading Capacity (kg)	Net Weight (kg)	Dimensions (mm)
M40A	1.8	220	40	65/102/296	12	210	680x540x1150

60L Planetary Food Mixer

Product Description

- Great for mixing, beating, whipping batters, cake mixes and the occasional dough or pastry. Thanks to their multitude of functions, they are the best partner for professional cooks.
- Ergonomic style bowl lift, and a removable safety guard make it incredibly easy to remove them for cleaning and maintenance without tools.
- Integrated emergency stop, motor overload protection, cover opening protection and bowl sliding protection ensure the operator's safety.
- The non-welded brushed stainless steel bowl adopts a one-step molding technique which enhances durability.
- Supplied standard with stainless steel safety guard, stainless steel bowl, beater, whip and dough hook for increased utility and functionality.



Specifications

Model	Power (kW)	Voltage (V)	Capacity (L)	Mixing Speed (r/min)	Max Kneading Capacity (kg)	Net Weight (kg)	Dimensions (mm)
M60A	2.2/2.8	380	60	73/109/143/216	20	490	1030x620x1430

80L Planetary Food Mixer

Product Description

- Great for mixing, beating, whipping batters, cake mixes and the occasional dough or pastry. Thanks to their multitude of functions, they are the best partner for professional cooks.
- Ergonomic style bowl lift, and a removable safety guard make it incredibly easy to remove them for cleaning and maintenance without tools.
- Integrated emergency stop, motor overload protection, cover opening protection and bowl sliding protection ensure the operator's safety.
- The non-welded brushed stainless steel bowl adopts a one-step molding technique which enhances durability.
- Supplied standard with stainless steel safety guard, stainless steel bowl, beater, whip and dough hook for increased utility and functionality.



Specifications

Model	Power (kW)	Voltage (V)	Capacity (L)	Mixing Speed (r/min)	Max Kneading Capacity (kg)	Net Weight (kg)	Dimensions (mm)
B80	3.0/4.0	380	80	89/133/174/262	30	720	1200x700x1650

Accessories

B&M Series Hooks

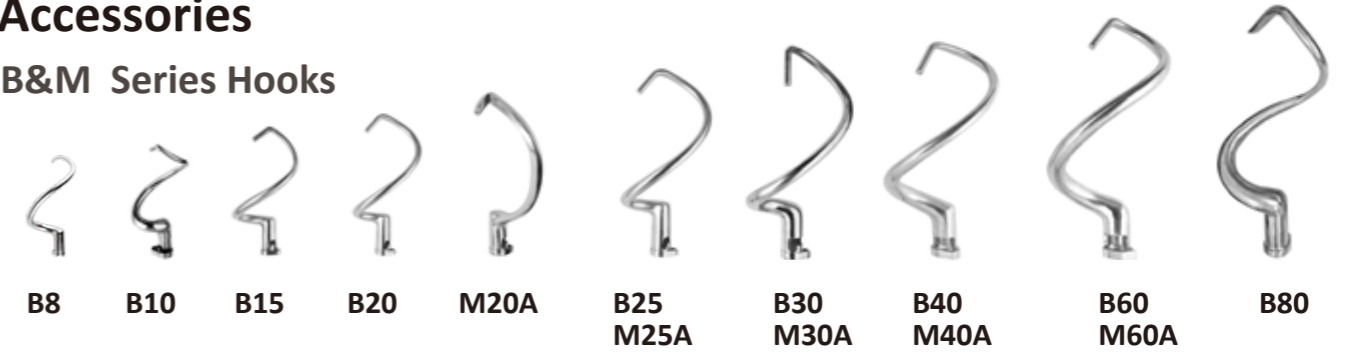

B&M Series Whips

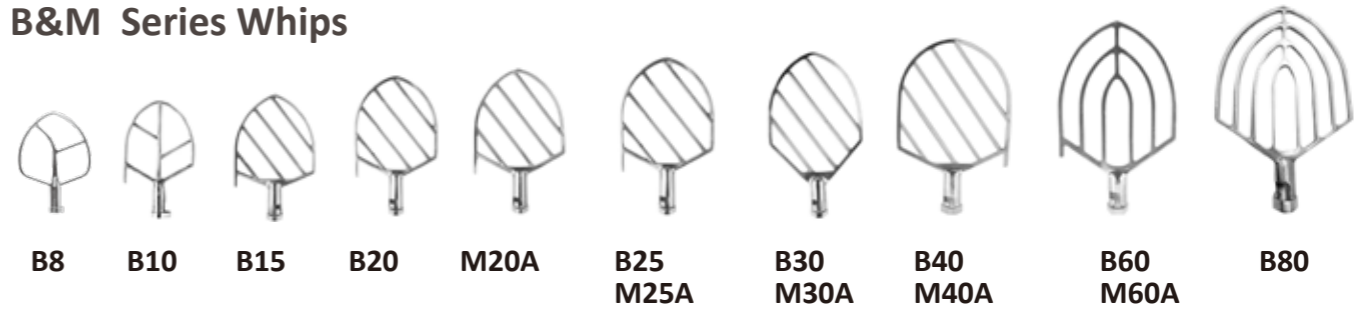

B&M Series Beaters



B&M Series Barrels



Spiral Mixer



Stepless Speed Spiral Mixer

Product Description

- CE and ETL Listed
- Stepless speed controller spiral mixer, you don't need to stop the machine from changing the speed.
- The speed range from 100~240r/min, the big speed range can mix the flour more finely.
- Single phase and three phases optional, come with the timer and emergency button.
- Belt and gear transmission system, Copper motor, powerful and quiet, wear-resisting opti belt.
- Capacity from 10L to 60L, Safety switch, and motor overload protection.



Specifications



Model	Bowl Volume (L)	Power (kW)	Voltage (V)	Mixing Speed (r/min)	Bowl Speed (r/min)	Max Kneading Capacity (kg)	Net Weight (kg)	Dimensions (mm)
LB20	20	0.75	220	100-240	10-28	8	60	685x400x635
LB30	30	1.1	220	100-240	10-28	12	80	730x440x685
LB40	40	2.2	220	100-240	10-28	16	115	830x480x715
LB50	50	2.2	220	100-240	10-28	20	120	850x530x715
LB60	60	2.5	220	100-240	10-28	25	130	850x530x780

Stepless Speed Spiral Mixer

Product Description

- CE and ETL Listed
- Stepless speed controller spiral mixer, you don't need to stop the machine from changing the speed.
- The speed range from 100~240r/min, the big speed range can mix the flour more finely.
- Single phase and three phases optional, come with the timer and emergency button.
- Belt and gear transmission system, Copper motor, powerful and quiet, wear-resisting opti belt.
- Capacity from 10L to 60L, Safety switch, and motor overload protection.



Specifications



Model	Bowl Volume (L)	Power (kW)	Voltage (V)	Mixing Speed (r/min)	Bowl Speed (r/min)	Max Kneading Capacity (kg)	Net Weight (kg)	Dimensions (mm)
LB20C	20	0.75	220	100-240	10-28	8	60	685x400x635
LB30C	30	1.1	220	100-240	10-28	12	80	730x440x685
LB40C	40	2.2	220	100-240	10-28	16	115	830x480x715
LB50C	50	2.2	220	100-240	10-28	20	120	850x530x715
LB60C	60	2.5	220	100-240	10-28	25	130	850x530x780

Spiral Mixer

Commercial Spiral Mixer

Product Description



- CE and ETL Listed
- Durable design
- Easy-access front panel controls
- Perfect for bakeries and pizza shops
- Integrated emergency stop and bowl guard cover opening protection.
- The Model come with A has two speed to mixing,kneading performance is more better.
- The gap between the hook and bowl is less than 5mm, obtaining the best dough kneading performance
- Can be used with wide variety of dough products.



LM20

Specifications

Model	Bowl Volume (L)	Power (kW)	Voltage (V)	Mixing Speed (r/min)	Bowl Speed (r/min)	Max Kneading Capacity (kg)	Net Weight (kg)	Dimensions (mm)
LM10	10	0.55	220	165	15	5	62	610X350X730
LM20	Single Speed 20	0.75	220	202	16	8	70	690x380x730
LM20BA	Two Speeds 20	0.90	220	101/202	8/16	8	70	690x380x760
LM30	Single Speed 30	1.1	220	202	16	12	90	730x430x770
LM30A	Two Speeds 30	0.85/1.1	380	101/202	8/16	12	90	730x430x770
LM30BA	Two Speeds 30	1.1	220	101/202	8/16	12	90	730x430x800

Commercial Spiral Mixer

Product Description

- CE and ETL Listed
- Durable design
- Easy-access front panel controls
- Perfect for bakeries and pizza shops
- Integrated emergency stop and bowl guard cover opening protection.
- The Model come with A has two speed to mixing,kneading performance is more better.
- The gap between the hook and bowl is less than 5mm, obtaining the best dough kneading performance
- Can be used with wide variety of dough products.



LM50A

Specifications

Model	Bowl Volume (L)	Power (kW)	Voltage (V)	Mixing Speed (r/min)	Bowl Speed (r/min)	Max Kneading Capacity (kg)	Net Weight (kg)	Dimensions (mm)
LM40	Single Speed 40	2.2	220	202	16	16	127	870x480x935
LM40A	Two Speeds 40	1.1/2.2	380	101/202	8/16	16	127	870x480x935
LM50	Single Speed 50	2.2	380	202	16	20	130	920x530x935
LM50A	Two Speeds 50	1.1/2.2	380	101/202	8/16	20	130	920x530x935



Spiral Mixer

80L Commercial Spiral Mixer

Product Description

- Copper motor, powerful and quiet , wear resisting Opti belt from Taiwan
- Safety switch and motor overload protect
- Metal body with 4mm of thickness, solid and durable, ensuring a stable working status.
- The new designed "S" shaped hook makes sure a complete mixing, and works more efficiently than the traditional design.
- Thickened solid material for barrel base to ensure the stableness when it is kneading.
- Spiral mixer is transmitted by belt, double motors



Panel



Barrels



Specifications

Model	Bowl Volume (L)	Power (kW)	Voltage (V)	Mixing Speed (r/min)	Bowl Speed (r/min)	Max Kneading Capacity (kg)	Net Weight (kg)	Dimensions (mm)
LM-80	80	1.5/2.4	380	107/210	16	25	429	1150x750x1325

100L Commercial Spiral Mixer

Product Description

- Copper motor, powerful and quiet , wear resisting Opti belt from Taiwan
- Safety switch and motor overload protect
- Metal body with 4mm of thickness, solid and durable, ensuring a stable working status.
- The new designed "S" shaped hook makes sure a complete mixing, and works more efficiently than the traditional design.
- Thickened solid material for barrel base to ensure the stableness when it is kneading.
- 100 L is transmitted by belt, double motors



Panel



Barrels



Specifications

Model	Bowl Volume (L)	Power (kW)	Voltage (V)	Mixing Speed (r/min)	Bowl Speed (r/min)	Max Kneading Capacity (kg)	Net Weight (kg)	Dimensions (mm)
LM-100	100	3/4.5	380	107/210	16	40	470	1150x750x1380

Spiral Mixer

130L Commercial Spiral Mixer

Product Description

- lift-up off-cylinder types speed-adjusting mixer series
- The specially designed kneading rod can coordinate the rotation speed with the bucket to obtain the best kneading effect.
- Specially set time control operation procedures, digital adjustment, and surface speed, with timer, can automatically stop.
- The barrel can be disassembled for easy cleaning.
- 130 L is transmitted by belt, double motors



Panel



Barrels

Specifications

Model	Bowl Volume (L)	Power (kW)	Voltage (V)	Mixing Speed (r/min)	Bowl Speed (r/min)	Max Kneading Capacity (kg)	Net Weight (kg)	Dimensions (mm)
LM-130	130	2.8/5.6	380	107/210	16	50	507	1250x750x1430

200/260L Commercial Spiral Mixer

Product Description

- Copper motor, powerful and quiet, wear resisting Opti belt from Taiwan
- Safety switch and motor overload protect
- Metal body with 4mm of thickness, solid and durable, ensuring a stable working status.
- The new designed "S" shaped hook makes sure a complete mixing, and works more efficiently than the traditional design.
- Thickened solid material for barrel base to ensure the stableness when it is kneading.
- 200/260 L is transmitted by belt, double motors



Panel



Barrels

Specifications

Model	Bowl Volume (L)	Power (kW)	Voltage (V)	Mixing Speed (r/min)	Bowl Speed (r/min)	Max Kneading Capacity (kg)	Net Weight (kg)	Dimensions (mm)
LM-200	200	5/7.5	380	107/210	16	75	675	1400x1080x1630
LM-260	260	5.5/11	380	107/210	16	100	735	1400x1080x1650

Spiral Mixer

Commercial Spiral Mixer

Product Description

- Electronically controlled variable-speed, durable and convenient manipulation
- Single-phase two-speed electronically controlled, patented product
- The specially designed mixing bar matched with the perfectly adjusted rotation speed, achieves the best kneading.
- It is also specially equipped with time control operating procedures, automatically controls the kneading time with both low and high speed, and shutdown by itself when time is up.
- It has timing and manual settings, high-speed and low-speed switch buttons, you can control the kneading time at either speed.
- You can also use the inching button in order to take out the dough or clean the barrel.



HS20T



HS20

Specifications

Model	Bowl Volume (L)	Power (kW)	Voltage (V)	Mixing Speed (r/min)	Bowl Speed (r/min)	Max Kneading Capacity (kg)	Net Weight (kg)	Dimensions (mm)
HS10T	10	0.75	220	80-200	6-16	4	60	660x310x650
HS20T	20	1.5	220	80-200	6-16	8	88	720x400x720
HS30T	30	1.8	220/380	140/200	11/16	12	125	880x440x820
HS40T	40	2.2	220/380	140/200	11/16	16	140	920x490x820
HS20	20	1.5	220/380	112/198	15/20	8	90	730x390x900
HS30	34	1.5	220/380	112/198	15/20	12	100	750x435x900
HS40	45	3	220/380	112/198	15/20	16	115	800x480x970
HS50	54	3	220/380	112/198	15/20	20	125	850x510x970
HS60	64	3	220/380	112/198	15/20	25	130	850x510x970

Automatic Tilting Spiral Mixer

Product Description

- Copper motor, powerful and quiet
- Wear resisting Opti belt from Taiwan
- Safety switch and motor overload protect
- Metal body with 4mm of thickness, solid and durable, ensuring a stable working status.
- The new designed "S" shaped hook makes sure a complete mixing, and works more efficiently than the traditional design.
- Durable AC contactor.
- Barrel is made of 304 stainless steel
- The whole machine is driven by belt, with three motors. The rollover function can be manually or automatically controlled. There are two mixing speeds with programmable timer, which are used in bakery and cake shop, greatly reducing the working time.



Specifications

Model	Bowl Volume (L)	Power (kW)	Voltage (V)	Mixing Speed (r/min)	Bowl Speed (r/min)	Max Kneading Capacity (kg)	Net Weight (kg)	Dimensions (mm)
LMF-200	200	13.5	380	180/90	17	100	890	1540x1540x1650
LMF-260	260	16.5	380	240/120	18	120	1000	1640x1640x1750
LMF-300	300	16.5	380	240/120	18	150	1100	1700x1640x1800

GM Spiral Mixer



70/130L Commercial Spiral Mixer

Product Description

- Professional durable design heavy-duty 2 Speed spiral mixer
- Easy-access front panel controls
- Integrated emergency stop and bowl guard cover opening protection.
- Can be used with wide variety of dough products, Perfect for bakeries and pizza shops
- Built-in programmable timer, Professional and reliable
- German belts drive durably without noise
- The non-welded 304 stainless steel bowl adopts one-step molding technique and enhances durability
- The gap between the hook and bowl is less than 3mm, obtaining the best dough kneading performance
- Bowl positive inversion



Specifications

Model	Bowl Volume (L)	Power (kW)	Voltage (V)	Mixing Speed (r/min)	Bowl Speed (r/min)	Max Kneading Capacity (kg)	Net Weight (kg)	Dimensions (mm)
LR-GM-25B	70	1.5/2.4	380	120/240	20/40	25	300	989X575X1240
LR-GM-50B	130	3/4.5	380	120/240	20/40	50	400	1100x700x1500

200L Commercial Spiral Mixer

Product Description

- Professional durable design heavy-duty 2 Speed spiral mixer
- Easy-access front panel controls
- Integrated emergency stop and bowl guard cover opening protection.
- Can be used with wide variety of dough products, Perfect for bakeries and pizza shops
- Built-in programmable timer, Professional and reliable
- German belts drive durably without noise
- The non-welded 304 stainless steel bowl adopts one-step molding technique and enhances durability
- The gap between the hook and bowl is less than 3mm, obtaining the best dough kneading performance
- Bowl positive inversion



Specifications

Model	Bowl Volume (L)	Power (kW)	Voltage (V)	Mixing Speed (r/min)	Bowl Speed (r/min)	Max Kneading Capacity (kg)	Net Weight (kg)	Dimensions (mm)
LR-GM-75B	200	4.5/9	380	120/240	20/40	75	650	1332x950x1510

PM Power Mixer

Features

- A lowered short ventilation slot and short spacing design is beneficial for water proofing and prevents foreign items from entering.
- Press on protect button can avoid the wrong operation effectively.
- Continuous operation is secured with a locking press button.
- Detaching the mixer is also made easy with a screw-type connection design.
- Permanent magnet DC motor with high efficiency ratio, small size, light weight and long operating life.
- Handle designed for easy grip and effortless use.
- The foot, blades and tube can all be taken apart for cleaning to ensure perfect hygiene.
- The tube, bell and blades are made from Stainless steel to ensure a longer life span.
- The model names that include T also possess a variable speed button that is positioned at the top of the appliance for ease of visibility and easier adjustment.



350 Series Blade

500/750 Series Blade

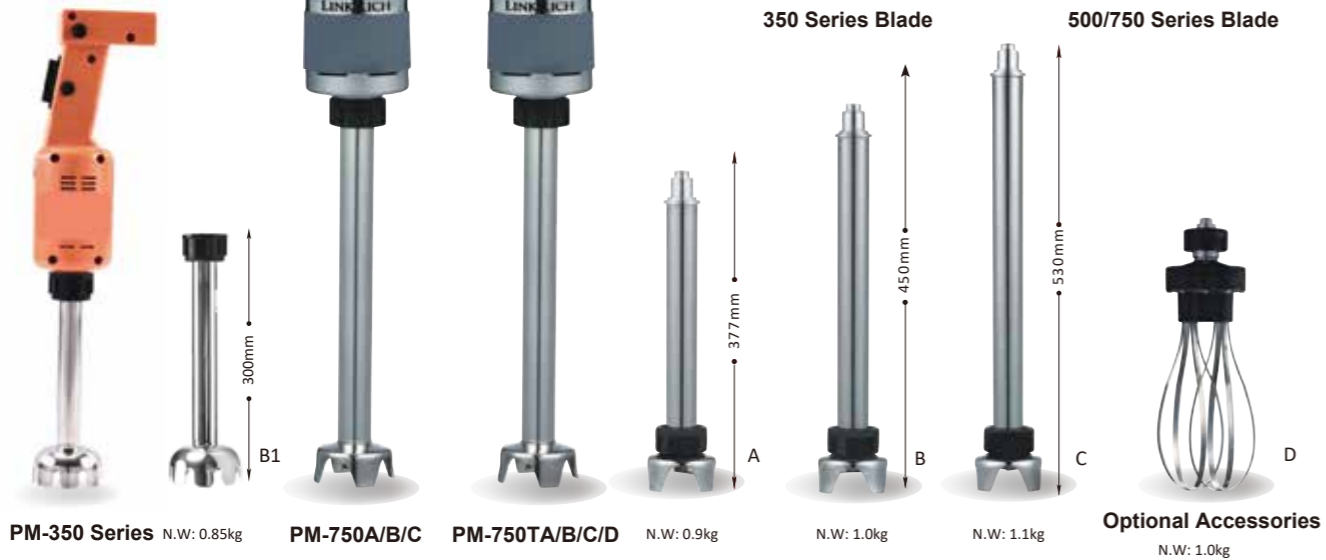

Note: PM-750T-AD, PM-750T-BD, PM-750T-CD with speed Switch

Model	Voltage (V)	Power (W)	Mixing Speed (r/min)	Net Weight (kg)
PM-350B	220	350	12000	1.4
PM-350WLB	220	350	3000~12000	1.4
PM-750A/B/C	220	750	12000	4
PM-750T-A/B/C	220	750	3800~12000	4
PM-750T-AD/BD/CD	220	750	3800~12000	6



PM Power Mixer

Features

- HP, heavy-duty motor
- 750W BLDC motor, the speed range from 3000~20000rpm.
- With speed control knob large input voltage range from 110 to 240 VAC&50/60 Hz without affecting output power.
- All purpose stainless steel blade.
- High efficiency due to BLDC working principle.
- Little heat dissipation which sustaining long time continuous operation.
- Stable torque force which does not decrease as rotation speed increases (this happens in the most prevailing immersion blenders using universal or brush DC motors)
- Ergonomic design for easy and comfortable operation
- Completely sealed stainless steel shaft, easily removable and dishwasher safe.
- Operating with protection and power button that avoid accidental switching ON.
- Operating with locking button for easy handling.

Model	PM-750W
Voltage	adapt to different input voltage range: 120v~, 208v~, 230v~, 240v~, 50/60Hz
Power	750W(rating), 1000W(Max)
Speed	3000-12000 rpm
Torque force	3Nm
Blender head	2.2kg



French Roll Moulder & Bread Moulder Machine

French Roll Moulder

Features

- The Moulder can process dough ranging from 50 grams up to 1.25 kg - Making it ideal for small rolls to large french baguettes.
- Easy to use controls allow precision fine tuning to achieve perfect results everytime.
- The unique natural felt is easy to replace, non-stick, non-marking and allows for gentler handling of the dough.
- Safety features include an emergency stop button and a safety switch.
- The unit comes on castors for easy mobility

Specifications

Model	Voltage (V)	Power (kW)	Productivity (pcs/time)	Dividing Weight (g/pcs)	Net Weight (kg)	Dimensions (mm)
LRF-750	380	0.75	1	50~1250	288	960x1010x1080



CG-280 Bread Moulder Machine

Features

- Reversible shifting devices.
- Operations concentrated on one side, a person can operate, save time.
- Job holding standardized uniform.
- Has a good closure, except the dough lightly pressed air inside.
- Conveyor has a positive reverse function can be used for many purposes.
- Safety, health, easy to clean.

Specifications

Model	Power (kW)	Voltage (V)	Inlet Size (mm)	Roll Size (mm)	Belt Size (mm)	Net Weight (kg)	Dimensions (mm)
CG-280	0.4	220	60x180	∅95x280	1325x330	145	1000x530x1060



LR-CG-38 Bread Moulder Machine

Features

- It is ideal for molding rolls, buns, toasts, baguettes, loaves, etc.
- The dough moulder use for molding and discharging air from raw materials to obtain quality end products.
- It has simple operation by switching on-off push bottom, as well as easily catching the dough with mobile steel tray both meet user-friendly demands for all clients.
- The roller system equipped in the dough moulder can adjust depend on the size and hardness of dough and can make the dough structure more solid. In addition, the roller spacing and conveyor belt can be well adjusted by hand wheel.

Specifications

Model	Power (kW)	Voltage (V)	Inlet Size (mm)	Roll Size (mm)	Belt Size (mm)	Net Weight (kg)	Dimensions (mm)
LR-CG-38	0.75	220	45x275	∅87x385	2300x380	208	1457x665x1090

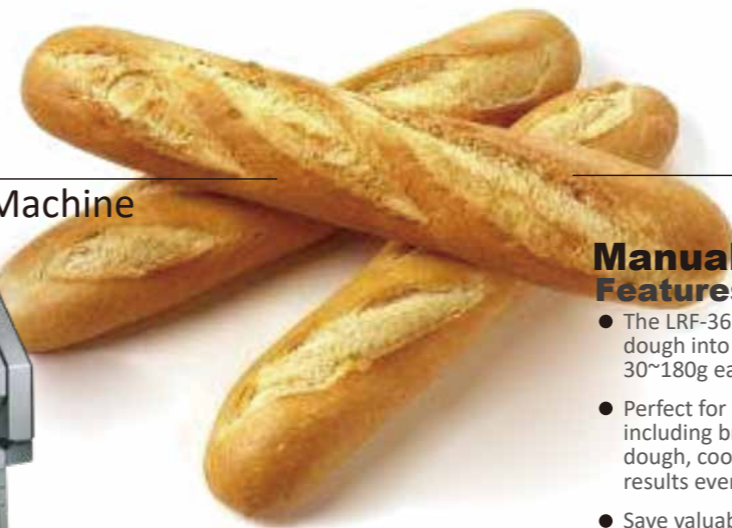

Bun Divider & Dough Divider

Manual Bun Divider Features

- The LRF-36M manual dough divider makes it easy to divide dough into 36 equal pieces, in weights ranging from 30~180g each!
- Perfect for a variety of different types of yeast-raised dough including bread dough, bun dough, tortilla dough, pizza dough, cookie dough, you'll achieve consistent, repeatable results every time.
- Save valuable time in the kitchen by using this manual dough divider to quickly.
- The simple handle-operated design makes it easy to use and requires less maintenance than an automatic machine.
- Simply place a bulk of dough into the operating area and pull the divider's handle to evenly portion your dough.
- Removable base, can save the space for loading.

Specifications

Model	Voltage (V)	Power (kW)	Productivity (pcs/time)	Dividing Weight (g/pcs)	Net Weight (kg)	Dimensions (mm)
LRF-36	Manual	-	36	30~180	61	530x450x600
LRF-36M	Manual	-	36	30~180	125	370x590x1160
LRF-36A	Manual	-	36	30~140	70	530x460x1620



Automatic Bun Divider Features

- With dough dividers, you can quickly form consistent and repeatable lumps of dough to bake the perfect bread loaves and buns.
- The Dividing Machine can process dough into 36 pcs, each ranging from 30grams up to 180 grams
- Stainless steel cutting knives
- Hydraulic system for gentle dough treatment and perfect products.
- With four wheel, it is convenient to move.
- HDD36 can be customized for 9 pcs, 20 pcs, 30 pcs and 36 pcs.

Specifications

Model	Voltage (V)	Power (kW)	Productivity (pcs/time)	Dividing Weight (g/pcs)	Net Weight (kg)	Dimensions (mm)
CG-36	380	1	36	30~180	193	505x408x1271
HDD36	220	1.5	36	30~120	224	520x420x1420



Commercial Dough Divider Features

- With dough dividers, you can quickly form consistent and repeatable lumps of dough to bake the perfect bread loaves and buns.
- The Dividing Machine can process dough into 20 pcs, each ranging from 100 grams up to 800 grams
- You can significantly cut down the time required for shaping and cutting dough and also save money by controlling the size of portions.

Specifications

Model	Material	Voltage (V)	Power (kW)	Productivity (pcs/time)	Dividing Weight (g/pcs)	Net Weight (kg)	Dimensions (mm)
LRF-20H	Spray Paint	380	1	20	100~800	425	660x700x1060
LRF-20S	Stainless Steel	380	1.5	20	135~800	350	640x660x980



Bun Divider and Roller

Semi-Automatic Bun Divider and Roller

Features

- Proven concept that the dough gently and make perfect round rolls
- The machine is on wheel and it comes standard with three synthetic food-approved
- Features of the innovative machines are the optimum ease of operation, with minimum effort, and high hourly production combined with a perfect baking result
- With permanent lubrication to protect transmission, this unit requires minimum maintenance
- Dividing and rounding are carried out in a semi-automatic way
- Very precise in the dividing and weight range produces a perfect rounded dough piece
- The shafts and moving parts are perfectly submerged in a oil bath

Specifications

Model	Voltage (V)	Power (kW)	The total weight of dough (kg)	Productivity (pcs/time)	Dividing Weight (g/pcs)	Net Weight (kg)	Dimensions (mm)
LRK-30	380	0.75	3	30	30~100	368	550x720x1350
LRK-36	380	0.75	2.8	36	20~80	368	550x720x1350



Automatic Bun Divider and Roller

Features

- Proven concept that the dough gently and make perfect round rolls
- The machine is on wheel and it comes standard with three synthetic food-approved
- Features of the innovative machines are the optimum ease of operation, with minimum effort, and high hourly production combined with a perfect baking result
- With permanent lubrication to protect transmission, this unit requires minimum maintenance
- Dividing and rounding are carried out in a semi-automatic way
- Very precise in the dividing and weight range produces a perfect rounded dough piece

Specifications

Model	Voltage (V)	Power (kW)	The total weight of dough (kg)	Productivity (pcs/time)	Dividing Weight (g/pcs)	Net Weight (kg)	Dimensions (mm)
LRF-30G	380	1.5	3	30	30~100	400	640x580x1500
LRF-36G	380	1.5	2.8	36	20~70	415	640x580x1500



Automatic Bun Divider and Roller

Features

- Proven concept that the dough gently and make perfect round rolls
- Features of the innovative machines are the optimum ease of operation, with minimum effort, and high hourly production combined with a perfect baking result
- Dividing and rounding are carried out in a semi-automatic way
- Very precise in the dividing and weight range produces a perfect rounded dough piece

Specifications

Model	Voltage (V)	Power (kW)	Productivity (pcs/time)	Dividing Weight (g/pcs)	Net Weight (kg)	Dimensions (mm)
LR-800	380	0.4	8000/hour	10~800	200	880x850x1400



Dough Sheeter

Dough Sheeter

- Large roller opening (40mm) with large hard chrome rollers
- Very large dough weight capacity
- Steel, stainless steel & aluminium
- Easy to remove & clean scraper assemblies with low replacement cost
- Safety guards with internal safety switching
- Quality food grade conveyor belt (not a cotton belt)
- No external switches to allow flour entry & subsequent damage
- Allows easy access in folded position to conveyor drive-rollers for cleaning

Specifications

Model	Power (kW)	Voltage (V)	Thickness (mm)	Roll Size (mm)	Belt Size (mm)	Net Weight (kg)	Dimensions (mm)
LSP530B	0.75	220	1-50mm	71x515	500x2000	220	945x2680x1270
LSP630B	0.75	220	1-50mm	71x600	585x2800	260	1040x3480x1270



Dough Sheeter

- Large roller opening (40mm) with large hard chrome rollers
- Very large dough weight capacity
- Steel, stainless steel & aluminium (not plastic components & casings like many other sheeters)
- Easy to remove & clean scraper assemblies with low replacement cost
- Safety guards with internal safety switching
- Quality food grade conveyor belt (not a cotton belt)
- No external switches to allow flour entry & subsequent damage
- Allows easy access in folded position to conveyor drive-rollers for cleaning (unlike other sheeters)

Specifications

Model	Power (kW)	Voltage (V)	Thickness (mm)	Roll Size (mm)	Belt Size (mm)	Net Weight (kg)	Dimensions (mm)
TSP450B	0.56	220	1-40mm	88x450	430x1700	117	820x1770x620
TSP520B	0.56	220	1-40mm	88x520	500x2000	125	880x2080x620
LSP520R	0.56	220	1-40mm	88x520	500x2160	190	880x2550x1180
LSP650R	0.72	220	1-40mm	88x650	630x2400	225	1100x2950x1180

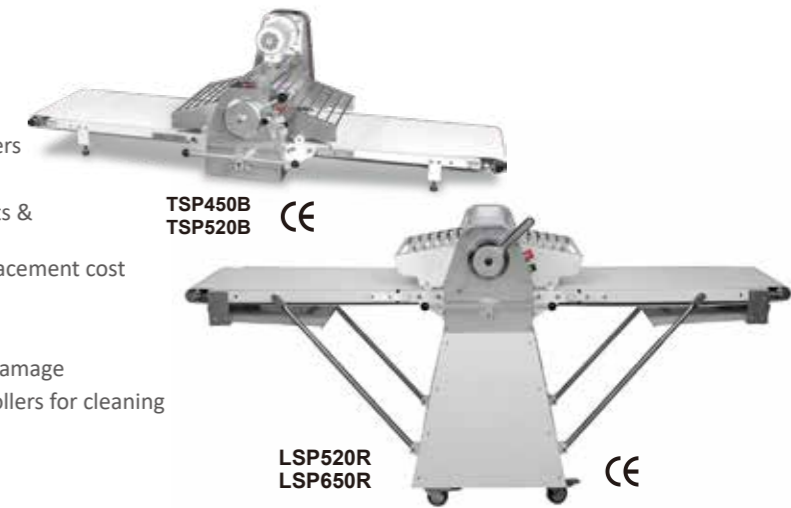

Automatic Dough Sheeter

- Very large dough weight capacity
- Steel, stainless steel & aluminium (not plastic components & casings like many other sheeters)
- Easy to remove & clean scraper assemblies with low replacement cost
- Safety guards with internal safety switching
- No external switches to allow flour entry & subsequent damage

Specifications

Model	Voltage (V)	Power (kW)	Dough Capacity (kg)	Roller Size (mm)	Conveyor Size (mm)	Net Weight (kg)	Dimensions (mm)
LR-800	380	1.5	12	650;880	3600x630	380	3920x1090x1360



Pizza Dough Roller

Product Description

- Only 3 seconds per pizza base.
- Thickness adjustment range from 1 to 4 mm.
- Dough Rollers are a must for any busy pizzeria or bakery that makes pies, pizzas or calzones.
- Eliminate the tedious process of manually rolling out dough by using an automatic dough roller that will yield perfect, consistent results every time.
- The simplicity of the machines means that untrained employees can create upwards of 250 crusts per hour of uniform thickness and shape
- Two pairs of adjustable rollers, to get a sheet of dough as many millimeters thick as you like, and for obtaining a round sheet
- A system of lower rollers and an idle roller favour the process of putting the dough into the machine
- Structure fully made of stainless steel and food safe resin roller, meet health and safety regulations.
- Designed to cold work the dough so as not to alter its characteristics.



APD-40
CE



APD-30
CE



APD-40E
CE

Specifications

Model	Power (kW)	Voltage (V)	Pizza Diameter (cm)	Maximum Capacity	Net Weight (kg)	Dimensions (mm)
APD-30	0.37	220	10 to 30		33	340x505x700
APD-40	0.45	220	10 to 40	20~700g for pizza base	40	480x560x700
APD-40E	0.37	220	10 to 40	20~1400g for dough presser	38	370x565x715

Bread Slicer

Product Description

The bread slicer is a high-performance machine that takes up very little counter space and is perfect for bakeries, specialty sandwich stores, hotels, cafes and trendy bread joints.

- Bread Width: 375mm max
- Bread Height: 14.5mm max
- Capacity: 240 breads per hour, Can cut 31/39 pcs 12mm thickness breads One time
- Optional blade distance. 31D: 10-30mm; 39D: 12mm/15mm



Specifications

Model	Power (kW)	Voltage (V)	Number of Bread (pcs)	Bread Size (mm)	Net Weight (kg)	Dimensions (mm)
CG-31D	0.2	220	31	150x375	70	630x630x685
CG-39D	0.2	220	39	150x475	80	675x630x740

Multifunctional Filling Dispenser

Product Description

- The Multifunctional Filling Dispenser is an innovative and advanced equipment that can automatically pour accurate quantities of semi fluid materials.
- It can also be used to inject fillings into breads, cakes, cream puffs, and other pastries.
- This machine is suitable for large food factories, bakery chains, and even hotel pastry kitchens.



Specifications

Model	Power (kW)	Voltage (V)	Capacity (L)	Net Weight (kg)	Dimensions (mm)
CG-23	0.25	220	6.5	7.5	445x320x445

Dumpling Machine

Dumpling Machine

Features

- This machine has the characteristics of small size, simple operation and convenient maintenance.
- The parts in contact with food are made of stainless steel, which meet the food processing hygiene requirements.
- It is suitable for processing all kinds of meat fillings, meat and vegetable fillings and other similar fillings with hotels, restaurants, canteens and small food processing enterprises.
- The dough thickness can be adjusted, the filling amount can be adjusted, the surface speed can be adjusted, and the forming head can be easily replaced.



DP60

DP120

Specifications

Model	Power (kW)	Voltage (V)	Productivity (pcs/h)	Dumpling Weight (g)	Net Weight (kg)	Dimensions (mm)
DP60	0.55	220	3600	11~12	53	500x240x550
DP120	1.5	220	7200	16~18	160	900x470x1150

Dumpling Machine

Features

- The Main part of this machine are all made of stainless steel, and the conveying surface and forming parts adopt square bonding technology.
- The thickness and thickness of dumpling made by the machine can be adjusted.
- The appearance of the product is beautiful, its conveyor belt dumpling machine.



DP135

DP200

Specifications

Model	Power (kW)	Voltage (V)	Productivity (pcs/h)	Dumpling Weight (g)	Net Weight (kg)	Dimensions (mm)
DP135	1.5	220	8100	14~16	160	990x470x1150
DP200	1.68	220	360-12000	14~15	220	1005x520x1540

Noodle Machine & Dough Press Machine

Noodle Machine

Features

- Chain driving, efficient and quiet.
- Magnetic control switch, safe and stable.
- The roller is processed by external grinding, lasting and durable.
- The roller is made of 304 stainless steel to prevent from rusty
- Vertical plate is made of cast iron, stable and strong.
- National standard copper 1uire motor, stable and durable
- The body is made of mirror stainless steel, high class and luxury.

Material of Fuselage: Model with S: Stainless steel, model without S: Painted



Model	Voltage	Power	Roller Speed	Roller Length	Capacity	Net Weight	Dimension
MT25	220V	1.1kW	69r/min	190mm	20-30kg	69kg	390x330x860mm
MT30	220V	1.5kW	69r/min	240mm	30-35kg	74kg	440x330x860mm
MT35	220V	2.2kW	69r/min	290mm	35-40kg	79kg	490x330x860mm
MT25S	220V	1.1kW	69r/min	190mm	20-30kg	69kg	390x330x860mm
MT30S	220V	1.5kW	69r/min	240mm	30-35kg	74kg	440x330x860mm
MT35S	220V	2.2kW	69r/min	290mm	35-40kg	79kg	490x330x860mm

Dough Press Machine

Features

- Easy operation with an on/off button
- Easy to clean and is heavy duty
- The thickness of the dough can be easily adjusted to your needs.
- Made from high quality stainless steel.
- High productivity and a low energy cost.



MT25I

MTS300

Model	Voltage	Power	Slice width	Net Weight	Dimension
MT25I	220V	0.37kW	210mm	32kg	330x250x320mm
MTS300	220V	1.5kW	290mm	68kg	480x290x800mm
MTS400	220V	2kW	340mm	68kg	530x290x800mm



Fresh Meat Slicer and Cutter

Features

- Machine body is made of thickened stainless steel, with surface brushed treatment.
- Imported blade, sharp and wearable.
- Protective cover design for safety protection.
- Copper turbine, long-lasting wearable.
- Slice thickness can be adjusted by changing the blades set.
- National standard copper wire motor, stable and durable.



Model	Voltage	Power	Cutting Thickness	Output	Net Weight	Dimension
TQ250	220V	600W	3mm	250kg/h	35kg	350x480x500mm
TQ500	220V	1.1kW	3mm	500kg/h	39kg	350x510x500mm

Fresh Meat Slicer and Cutter

Features

- Machine body is made of thickened stainless steel, with surface brushed treatment.
- Imported blade, sharp and wearable.
- Protective cover design for safety protection.
- Belt driving, wearable and quiet.
- Slice thickness can be adjusted by changing the blades set.
- National standard copper wire motor, stable and durable.



Model	Voltage	Power	Cutting Thickness	Output	Net Weight	Dimension
TQ600	220V	750W	3mm	600kg/h	38kg	280x500x800mm

Fresh Meat Slicer and Cutter

Features

- Machine body is made of thickened stainless steel, with surface brushed treatment.
- Imported blade, sharp and wearable.
- Double cutter design, makes meat thickness come out evenly.
- Protective cover design for safety protection.
- Belt driving, wearable and quiet.
- Slice thickness can be adjusted by changing the blades set.
- National standard copper wire motor, stable and durable.



Model	Voltage	Power	Cutting Thickness	Output	Net Weight	Dimension
TQA800	220V	750Wx2	5mm	800kg/h	125kg	650x600x820mm



Countertop Stainless Steel Meat Mincer

Features

- Ideal for small butcher shops, delis and restaurants.
- Includes replacement knife, plastic pusher, meat tray, grinder plates.
- Using a low speed and high torque process, the food retains all of its nutrients after it has been processed.
- The head and body structures are separate, allowing for a much easier clean and safer product to the customer's health.
- Copper gear-driven transmission, making it incredibly durable.



Specifications

Model	Voltage (V)	Power (kW)	Production Capacity (kg/h)	Net Weight (kg)	Dimensions (mm)
TD-12	220	0.55	62	29	400x270x500
TD-22	220	0.75	100	32	460x280x530

Stainless Steel Meat Mincer

Features

- Ideal for small butcher shops, delis and restaurants.
- Includes replacement knife, plastic pusher, meat tray, grinder plates.
- Using a low speed and high torque process, the food retains all of its nutrients after it has been processed.
- The head and body structures are separate, allowing for a much easier clean and safer product to the customer's health.
- Copper gear-driven transmission, making it incredibly durable.



Specifications

Model	Voltage (V)	Power (kW)	Production Capacity (kg/h)	Net Weight (kg)	Dimensions (mm)
TT-12G	220	0.75	120	35	456x290x490
TT-22G	220	1.1	220	38	458x290x490
TT-32G	220	2.2	320	52	524x298x541

Countertop Stainless Steel Meat Mincer

Features

- Ideal for small butcher shops, delis and restaurants.
- This compact-design chopper can be fed at a rapid pace with continuous chopping action.
- This Chopper has a fresh meat capacity of 320kg per hour.
- Includes replacement knife, plastic pusher, meat tray, grinder plates.
- Using a low speed and high torque process, the food retains all of its nutrients after it has been processed.



Specifications

Model	Voltage (V)	Power (kW)	Production Capacity (kg/h)	Net Weight (kg)	Dimensions (mm)
TT-32E	220/380V	2.2	320	80	735x380x500

Standing Stainless Steel Meat Mincer

Features

- Ideal for small butcher shops, delis and restaurants.
- This compact-design chopper can be fed at a rapid pace with continuous chopping action.
- This Chopper has a fresh meat capacity of TC-42AE 600kg per hour and TC-52AE 1200kg per hour.
- Includes replacement knife, plastic pusher, meat tray, grinder plates.
- Using a low speed and high torque process, the food retains all of its nutrients after it has been processed.
- The head and body structures are separate, allowing for a much easier clean and safer product to the customer's health..



Specifications

Model	Voltage (V)	Power (kW)	Production Capacity (kg/h)	Net Weight (kg)	Dimensions (mm)
TC-42AE	380	4	600	158	1095x535x955
TC-52AE	380	5.5	1200	285	1240x630x1080

Commercial Manual Hamburger Patty Press

Patty Press Manually Operated, Single Burger Molds

Features

- WF-A is anodized aluminum base and stainless steel bowls offer a durable, heavy-duty construction, designed for high-volume use.
- This patty press is controlled with a simple, single-level press handle for easy operation.
- Its compact, ergonomic design makes this ideal for storage and saving essential counter space.



Model	Patty.Dia (mm)	Patty.Height (mm)	Net Weight (kg)	Dimensions (mm)
WF-A100	115	35	5.2	275x230x300
WF-A130	135	35	5.8	275x230x300

Meatball Beater

Features

- Reasonable design, convenient operation and high efficiency
- In line with national health requirements parts are made of stainless steel or electrolating.
- Suitable for restaurants, shops, factories.

Specifications

Model	Voltage (V)	Power (kW)	Woring Efficiency (kg/times)	Net Weight (kg)	Dimensions (mm)
LR-18R/18ER	220	1.1	2	23	320x320x820
LR-20R/20ER	220	1.5	2.5	25	320x350x820
LR-22R/22ER	220	2.2	3	30	370x390x830
LR-24R/24ER	220	3	3.5	35	370x420x830
LR-30R	220	3	8	50	460x410x860



Fish Meat Picker

Features

- Can use for pick fish, crab and shrimp meat.
- The machine made of 304 stainless steel, which is meet the food requirement.
- Powerful motor ensures efficient production and large output.



Specifications

Model	Voltage (V)	Power (kW)	Yield (kg/h)	Belt Thickness (mm)	Belt Length (mm)	Diameter (mm)	Net Weight (kg)	Dimensions (mm)
LR-150M	220	2.2/1.5	180	20	1240	2.7/3/3.2	180	850x700x900
LR-200M	220	2.2/1.5	250	20	1470	2.7/3/3.2	240	940x800x930
LR-300M	220	3	500	20	1470	2.7/3/3.2	280	1100x700x930
LR-350M	220	7.5	1500	20	250	2.7/3/3.2	750	1300x1000x1050

Meatballs Forming Machines

Features

- The machine made of stainless steel and the meatball it formed with copper ring, more hygienic and durable.
- Easy for operation, efficient production and large output.
- The Mold specification its $\phi 18\text{mm}/\phi 22\text{mm}/\phi 26\text{mm}$, Also $\phi 11\text{mm}$ and $\phi 36\text{mm}$ can be customized.

Specifications

Model	Voltage (V)	Power (kW)	Woring Efficiency (pcs/min)	Net Weight (kg)	Dimensions (mm)
LR-280T	220/380	1.1	280~300	70	420x360x820
LR-280L	220/380	1.1	280~300	80	750x450x1230



Sausage Stuffer

Manual Sausage Stuffer

Features

- For Maximum performance, this sausage stuffer boasts an enclosed two speed gearing to drive the piston and a pressure release valve.
- It's good Ideal for all kinds of kitchen.
- Durable and heat free operation.
- Includes four stuffing funnel sizes(16mm/22mm/32mm/38mm).
- Vertical design saves countertop space.

Specifications

Model	Capacity (L)	Bowl Size (mm)	Net Weight (kg)	Dimensions (mm)
TV-3L	3.5	200x149	3	320x280x520
TV-5L	5.5	320x149	5	320x280x620
TV-7L	7.9	450x149	7	320x280x760
TV-10L	11	325x219	22	320x420x640
TV-15L	15	405x219	24	320x420x760



Manual Sausage Stuffer

Features

- Manual horizontal enema machine series, double speed design, each model are made of high quality stainless steel material.
- The shell integration, steel gear drive, sturdy and durable.
- The size of gear shaft and the driving rack of high surface electroplating food grade chromium.
- Two gear seat(cast aluminum and cast iron) as you choose.
- The integration of a material barrel, to make food more health.

Specifications

Model	Capacity (L)	Bowl Size (mm)	Net Weight (kg)	Dimensions (mm)
HV-3L	3.5	200x149	9	400x200x158
HV-5L	5.5	320x149	11	520x200x158
HV-7L	7.9	450x149	13	650x200x158



Electric Sausage Stuffer

Features

- Durable and heat free operation.
- Vertical design saves countertop space.
- For Maximum performance, this sausage stuffer boasts an enclosed two speed gearing to drive the piston and a pressure release valve.
- It's good Ideal for all kinds of kitchen.
- Includes four stuffing funnel sizes(16mm/22mm/32mm/38mm).
- Come with the pedal control, it's more convenient for workers to operate

Specifications

Model	Voltage (V)	Power (kW)	Capacity (L)	Net Weight (kg)	Dimensions (mm)
TE-10L	220	0.12	10	40	320x420x670
TE-15L	220	0.12	15	42	320x420x800
TE-20L	220	0.25	20	46	330x440x800
TE-25L	220	0.25	25	50	330x440x900
TE-30L	220	0.25	30	55	330x440x990



Sausage Stuffer & J Bone Saw Machine

Hydraulic Sausage Stuffer

Features

- Oil system lifting sausage up and down, low noise and high efficiency.
- Mobile body ensure greater applicability.
- Motor housing is completely enclosed and a tube is supplied to cover the gear bar when in operation or for storage.
- Work at your comfort level,Use a slower speed for snack sticks to you don't have casing blowouts.
- A faster speed can be used for larger size casings.



Knee-switch



Specifications

Model	Voltage (V)	Power (kW)	Bowl Dia (mm)	Bowl Volume (L)	Productivity (kg/h)	Net Weight (kg)	Dimensions (mm)
SF-150	220	0.55	φ200	15	300	125	600x400x1240
SF-260	220	0.75	φ260	26	400	150	640x485x1240
SF-350	220	1.1	φ320	35	600	175	735x560x1240

J Bone Saw Machine Aluminium Alloy 

Features

- The saw blade is made solid steel, making it firm and durable.
- The bench is made of high quality stainless steel, confirms to the international sanitation requirements.
- Ideal for cutting fresh meat or frozen meat,bones, fish etc in butcher shops,clubs,hotels and restaurants.
- With safty lock, when the machine outer covering open,will automatically switch off.
- The whole body is made of aluminum,and the parts in touch with food are made of high quality stainless steel.
- Efficient, runs steadily, easily operated and easy to clean.



J-210N
J-310N



Specifications

Model	Power (kW)	Voltage (V)	Cutting Thickness (mm)	Cutting Height (mm)	Rotational Speed (r/min)	Length of saw blade (mm)	Thickness of the saw blade (mm)	Size of the bench (mm)	Net Weight (kg)	Dimensions (mm)
J-210	0.65	220	5~155	0~180	1420	1650	0.5	500x380	41	520x470x820
J-210N	0.65	220	5~155	0~180	1420	1650	0.5	500x380	40.6	520x470x820
J-310	1.1	220	5~180	0~260	1420	2000	0.5	560x425	70	590x570x1040
J-310N	1.2	220	5~180	0~260	1420	2000	0.5	560x425	63	590x570x1040
J-380	1.1	380	5~260	0~270	1420	2490	0.5	440x340	142	930x770x1570
J-410	2.2	380	5~350	0~300	960	3460	0.5	450x580	256	1270x1020x1720

Bone Saw Machine

Bone Saw Machine Stainless Steel

Features

- Suitable for cutting through various meat bones, frozen meat, poultry and fish with ease.
- Stainless steel sliding table and fence components.
- Built-in grinder makes processing fast and easy.
- Has a front access panel for easy clean up.
- The upright design takes up less room.

Specifications

Model	Voltage (V)	Power (kW)	Commodity Height(mm)	Belt Wheel Dia.(mm)	Blade Speed (m/s)	Length of saw blade (mm)	Table Dimensions (mm)	Net Weight (kg)	Dimensions (mm)
JG210C	220	1.1	226/151	210	15	1650	595x415	50	630x515x950



Bone Saw Machine Stainless Steel

Features

- Suitable for cutting through various meat bones, frozen meat, poultry and fish with ease.
- Stainless steel sliding table and fence components.
- Built-in grinder makes processing fast and easy.
- Has a front access panel for easy clean up.
- The upright design takes up less room.

Specifications

Model	Voltage (V)	Power (kW)	Commodity Height(mm)	Belt Wheel Dia.(mm)	Blade Speed (m/s)	Length of saw blade (mm)	Table Dimensions (mm)	Net Weight (kg)	Dimensions (mm)
JG310C	220	1.5	440x245	300	22	2580	790x565	138	865x735x1700
JG410C	220	2.2	465x370	400	34	3172	880x760	171	900x960x1845
JG510C	220	2.2	566x345	400	34	3370	875x760	180	970x955x2100



Bone Saw Machine Spray Painting

Features

- Suitable for cutting through various meat bones, frozen meat, poultry and fish with ease.
- Stainless steel sliding table and fence components.
- Built-in grinder makes processing fast and easy.
- Has a front access panel for easy clean up.
- The upright design takes up less room.

Specifications

Model	Voltage (V)	Power (kW)	Commodity Height(mm)	Belt Wheel Dia.(mm)	Blade Speed (m/s)	Length of saw blade (mm)	Table Dimensions (mm)	Net Weight (kg)	Dimensions (mm)
JG210CA	220	1.1	231x166	210	15	1650	495x405	52	555x495x910
JG280CA	220	1.1	231x166	210	15	1830	494x405	54	555x495x1000



Bone Saw Machine & Plastic Strap Metal Mesh Glove

Bone Saw Machine Spray Painting

Features

- Suitable for cutting through various meat bones, frozen meat, poultry and fish with ease.
- Stainless steel sliding table and fence components.
- Built-in grinder makes processing fast and easy.
- Has a front access panel for easy clean up.
- The upright design takes up less room.

Specifications

Model	Voltage (V)	Power (kW)	Commodity Height(mm)	Belt Wheel Dia.(mm)	Blade Speed (m/s)	Length of saw blade (mm)	Table Dimensions (mm)	Net Weight (kg)	Dimensions (mm)
JG310CA	220	1.5	380x215	260	15	2218	675x550	91	710x695x1700
JG360CA	220	1.5	440x245	300	22	2580	790x565	150	905x780x1860



Five Finger Plastic Strap Metal Mesh Glove

Important Notice:

1. DO NOT wear the gloves while operating power rotating machine. Protection against injuries cannot be guaranteed when working with power driven blades/knives/saws or similar tools. The gloves provide no protection against chain saws.
2. For saw and knife blades have a tooth height of more than 1mm, no protection is guaranteed.
3. The gloves must have a comfortable secure fit. Over hanging chain nail can pulled into the machine which causes serious injuries. If the size is not suitable, please return and replace it.
4. It is better to wear a cotton glove in cold or humid conditions.
5. Avoid contact with electricity when wearing gloves.
6. Discard and replace the gloves if they become damaged.



Model	Belt	Sleeve Size
5101	Nylon	
5102	S/S	
Model	Belt	Sleeve Size
1101	Nylon	8cm, 15cm, 19cm, 22cm
1102	S/S	8cm, 15cm, 19cm, 22cm

Size Chart

Belt Color	XXS	XS	S	M	L	XL
Size						
Palm Length(mm)	210	225	235	245	255	260
Plam Width(mm)	105	110	120	125	130	135

Nylon belt:

Equipped with metal adjustment button design, adapt to different hand circumference, wear soft and comfortable, not easy to fatigue

S/S Belt:

Stainless steel hook wrist strap is all metal structure, rust and corrosion resistant, easy to clean and disinfected, more suitable for slaughter industry, especially aquaculture industry

Meat Slicer

Semi-automatic Meat Slicer

Features

- CE,Rohs and ETL Listed
- It's suited to large restaurants, supermarkets,delicatessens and butcher shops where high volume slicing is required for different varieties of meats.
- Manufactured from anodized aluminium with clean lines, the machine features a built-in sharpening head and blade ring-guard.
- With sharpener, which helps to use more convenient.
- The cut thickness is easily adjustable



Model	Power (kW)	Voltage (V)	Diameter (mm)	Max Slicing Size (mm)	Slicing Thickness(mm)	Net Weight (kg)	Dimensions (mm)
SL-195ES-6	0.18	220	195	120x115	0~12	12.5	390x360x320
SL-220ES-8	0.32	220	220	125x125	0~12	14	430x380x350
SL-250ES-10	0.32	220	250	160x150	0~12	16	480x370x360
SL-250ES-10A	0.32	220	250	160x150	0~12	16	480x370x360
SL-300ES-12	0.42	220	250	180x180	0~15	24.5	530x460x460
SL-300ES-12A	0.42	220	300	180x180	0~15	24.5	530x460x460

Semi-automatic Meat Slicer

Features

- CE,Rohs and ETL Listed
- The cut thickness is easily adjustable
- It's suited to large restaurants, supermarkets,delicatessens and butcher shops where high volume slicing is required for different varieties of meats.
- Manufactured from anodized aluminium with clean lines, the machine features a built-in sharpening head and blade ring-guard.
- With sharpener, which helps to use more convenient.

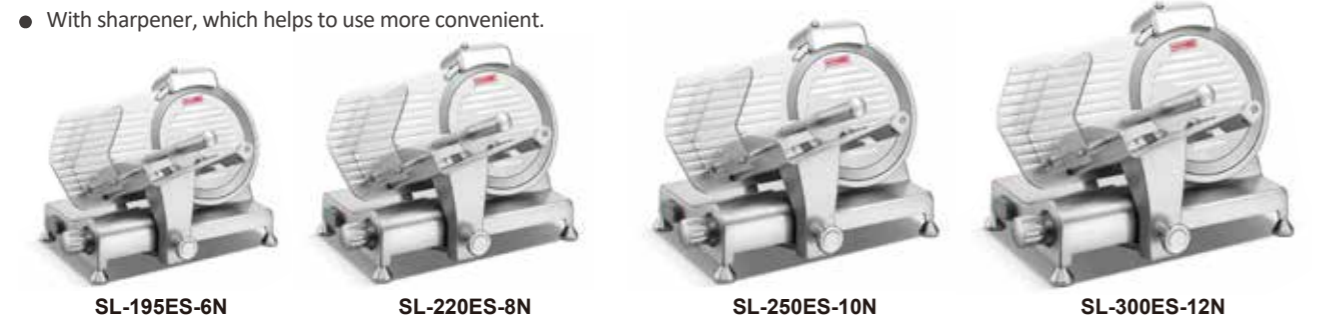

Model	Power (kW)	Voltage (V)	Diameter (mm)	Max Slicing Size (mm)	Slicing Thickness(mm)	Net Weight (kg)	Dimensions (mm)
SL-195ES-6N	0.2	220	195	160x150	0~12	12.5	390x360x320
SL-220ES-8N	0.28	220	220	180x180	0~12	14.2	440x380x340
SL-250ES-10N	0.32	220	250	160x150	0~12	16.8	490x390x380
SL-300ES-12N	0.42	220	300	180x180	0~15	26.3	600x430x460

Meat Slicer

Automatic Meat Slicer

Features

- CE,Rohs and ETL Listed
- It's suited to large restaurants, supermarkets,delicatessens and butcher shops where high volume slicing is required for different varieties of meats.
- Manufactured from anodized aluminium with clean lines, the machine features a built-in sharpening head and blade ring-guard.
- With sharpener, which helps to use more convenient.
- The cut thickness is easily adjustable



Specifications

Model	Power (kW)	Voltage (V)	Diameter (mm)	Max Slicing Size (mm)	Slicing Thickness(mm)	Net Weight (kg)	Dimensions (mm)
SL-300C(12'')	0.42	220	300	230x160	0~12	41	640x600x650
SL-300B	0.42	220	300	230x160	0~15	68	640x600x750

Automatic Meat Slicer

Features

- CE,Rohs and ETL Listed
- It's suited to large restaurants, supermarkets,delicatessens and butcher shops where high volume slicing is required for different varieties of meats.
- Manufactured from anodized aluminium with clean lines, the machine features a built-in sharpening head and blade ring-guard.
- With sharpener, which helps to use more convenient.
- The cut thickness is easily adjustable



Specifications

Model	Power (kW)	Voltage (V)	Diameter (mm)	Max Slicing Size (mm)	Slicing Thickness(mm)	Net Weight (kg)	Dimensions (mm)
SL-300E(12'')	0.42	220	195	230x160	0~15	47	600x540x680
SL-350B	0.75	220/380	350	-	0~18	228	1000x750x1450

LINKRICH FOOD PREPARATION

Vegetable Preparation Machines

Vegetable Preparation Machines

Features

- For safety, the motor stops when the attached pusher is opened more than 12" above the opening.
- A powerful 750W motor, a large feed entrance for mass food preparation and a functional vegetable cutter.
- Good looking with a compact design, the construction is made from a special alloy of aluminium and magnesium in accordance with health regulation standards.
- Multi-purpose multifunctional vegetable cutter: slicing, grating, shredding and cutting into chips or cubes of all sizes.
- High capability, versatile choice, work smoothly and low noise.
- Attachment: 5 different disc blades. Spec. For Slicing: SP002/SP004; For Grater: G003/G005/G007.



LR-MFC65

LR-MFC60

LR-MFC23

LR-MFC26

LR-MFC28

Heavy Duty Electric multifunction vegetable cutter.

	LR-MFC65	LR-MFC60	LR-MFC60	LR-MFC23	LR-MFC26	LR-MFC28
Voltage	220V	220V	220V	220V	220V	220V
Power	750W	550W	550W	250W	200W	200W
Blade Speed	329r/min	329r/min	329r/min	280r/min	280r/min	280r/min
Blade Dia	205mm	205mm	205mm	-	-	-
Output	≥180kg/h	≥150kg/h	≥150kg/h	100-150kg/h	100-150kg/h	100-150kg/h
Feeding Inlet Size	180x169mm	175x75mm	175x75mm	-	-	-
G.W/N.W	30/26	29/25	29/25	30/-	29/-	29/-
Dimension	560x270x480mm	560x275x480mm	560x275x480mm	610x335x610mm	610x335x610mm	610x335x610mm



Blades

For Grater



G002

G003

G005

G007

G010

For Slicing(Plastic)



SP002



SP004

For French Fries



FS808
FS100

For Dicing



DS1000/DS2000
DS888/DS140

For Slicing(Aluminium)



For Grater

SA002

SA004

SA006

SA008
SA010//SA014

J303/J404

MODEL	G002	G003	G005	G007	G010	J303/404
Specification	2mm	3mm	4.5mm	7mm	10mm	3x3mm/4x4mm

For Slicing

MODEL	SP002	SP004	SA002	SA004	SA006	SA008/SA100/SA014
Specification	2mm	4mm	2mm	4mm	6mm	8mm/10mm/14mm

For Dicing

MODEL	SA008/SA010/SA014	DS888/DS1000	DS140/DS2000	SA008/SA010	FS808/FS100
Specification	8mm 10mm/14mm	8x8x8mm 10x10x10mm	14x14x14mm 20x20x20mm	8mm 10mm	8x8mm 10x10mm

For French Fries



Heavy Duty Combination Processor

- Strong and robust casting aluminum housing .
- Very powerful and ventilated motor.
- Detachable blades and discs>
- Adjustable speeds control and pulse function.
- Safety micro-switch included.
- Transparent lid with opening to add ingredients during operation.
- Scraper accessory ensures a perfect result.
- The machine is designed and produced according to international standards for safety and hygiene.



Specifications

Model	Power (kW)	Voltage (V)	Speed (rpm)	Net Weight (kg)	Dimensions (mm)
LR-MFC70MF	1.5	220	500-3000	27.3/31.5	540x410x735

French Fries Cutting Machine

- The French fry cutter is suitable for cutting potatoes, radishes, taro, and other root vegetables into square-shaped strips or slices.
- The cut surface of the finished product is smooth and does not damage the texture.
- It is suitable for further steaming, boiling, or frying of the raw materials.
- It is suitable for use in fast food restaurants, manufacturers, or food processing factories.



Specifications

Model	Power (kW)	Voltage (V)	Efficiency (Kg/h)	Net Weight (kg)	Dimensions (mm)
PC-600	1.5	220	1000	105	710x1040x900

Vegetable Cutter Machine

- Stainless steel bowl and body
- Smooth S shape blade
- Easy for clean to take our the shape and bowl for wash
- With safety switch
- High efficiency,save time
- Easy to use



Specifications

Model	Power (kW)	Voltage (V)	Capacity (L)	Efficiency (Kg/h)	Net Weight (kg)	Dimensions (mm)
VC-200	0.75	220	20	800	23	380x280x780

Batch Bowl Food Processor

- The body is made from an aluminium - magnesium alloy for the 3/5/8L series, making it very durable.
- Waterproofed with a two seal ring inside, making for a safe operation.
- Contains a safety controller that stops the machine once the cover has been opened.
- Uses a stainless steel bowl.



White shell / Stainless steel shell
LR-QS-3L~LR-QS-8L



LR-QS-13L~LR-QS-15L



Garlic Pork Ginger Peanut Capsicum
A Knife with big S-shape, which has long blade wire.



Blade for 13L&15L



Blade for 3L&5L&8L

So it has the highest cutting efficiency and the best cutting effect.

Model	Voltage (V)	Power (kW)	Capacity (L)	Cutting Speed(r/min)	Net Weight (kg)	Dimensions (mm)
LR-QS-3LA	220	0.65	3	1400	30	230x300x480
LR-QS-5LA	220	1.5	5	1400	38	305x380x530
LR-QS-8LA	220	2.5	8	1400	56	370x445x615
LR-QS-13L	380	2.8/3.5	13	1300/2600	140	420x680x720
LR-QS-15L	380	2.8/3.5	15	1300/2600	143	420x680x770

Weight of cutting(once)

Model	Pork (kg)	Capsicum (kg)	Ginger, Garlic (kg)	Peanut (kg)	Tomato (kg)	Variety of Gutting	Timeof cutting(secs)
LR-QS-3LA	1.5	1	1.4	1.3	1.5	Pork	13
LR-QS-5LA	2.5	2	2.1	1.7	1.9	Capsicum	60
LR-QS-8LA	3.5	3	2.8	2.8	2.8	Ginger, Garlic	30
LR-QS-13L	10	5.5	5	5	4	Peanut	18
LR-QS-15L	12.5	8	7.5	7.5	6	Tomato	15

Batch Bowl Food Processor

Batch Bowl Food Processor

Batch Bowl Food Processor use the batch bowl to puree, chop, mix, and a variety of other tasks,exposing your employees to sharp knives that can easily cause injury

- Stainless steel bowl and body ,smooth S shape blade
- Easy for clean to take our the shape and bowl for wash
- With safety switch,high efficiency,save time,easy to use



A Knife with big S-shape, which has long blade wire. So it has the highest cutting efficiency and the best cutting effect.



Specifications

Model	Power (kW)	Voltage (V)	Capacity (L)	Cutting Speed (r/min)	Net Weight (kg)	Dimensions (mm)
LR-QS-804	0.55	220	4	1400	20.5	363x318x525
LR-QS-806	0.75	220	6	1400	22	425x365x560
LR-QS-810	1.1	220	10	1400	31	435x410x585
LR-QS-815	1.4	220	15	1400	33	500x460x670

Batch Bowl Food Processor

Batch Bowl Food Processor use the batch bowl to puree, chop, mix, and a variety of other tasks,exposing your employees to sharp knives that can easily cause injury

- Stainless steel bowl and body ,smooth S shape blade
- Easy for clean to take our the shape and bowl for wash
- With safety switch,high efficiency,save time,easy to use



A Knife with big S-shape, which has long blade wire. So it has the highest cutting efficiency and the best cutting effect.



Specifications

Model	Power (kW)	Voltage (V)	Capacity (L)	Cutting Speed (r/min)	Net Weight (kg)	Dimensions (mm)
LR-QS-3D	0.75	220	3	1400	22	320x310x555
LR-QS-5D	1.1	220	5	1400	29	370x350x630
LR-QS-8D	1.5	220	8	1400	38	380x400x735
LR-QS-13D	2.2	220	13	1400	55	420x415x820

Commercial Food Processing Cutter & Ingredient Mixing Machine

Commercial Food Processing Cutter

Features

- Suited for cutting up meat, vegetables and fruit.
- Contains a safety control that will stop the machine when the cover is opened.
- The heavier machines have four wheels, making them more convenient to move.
- All parts in contact with food are made of stainless steel.
- Easy to operate and have a high efficiency.
- Driven with an enclosed gear.



TQ-5A



QS620A

Specifications

Model	Power (kW)	Voltage (V)	Capacity (L)	Bowl Diameter (mm)	Output (kg/h)	Net Weight (kg)	Dimensions (mm)
TQ-5A	0.37	220	5	350	80	30	530x420x540
TQ-8A	0.75	220	8	480	120	50	800x550x550
QS620A <i>Spray Paint</i>	1.1	220	20	600	120	126	775x710x940
QS620B <i>S/S</i>	1.1	220	20	600	120	126	775x710x940

Commercial Food Processing Cutter

Features

- Suited for cutting up meat, vegetables and fruit.
- Contains a safety control that will stop the machine when the cover is opened.
- The heavier machines have four wheels, making them more convenient to move.
- Easy to operate and have a high efficiency.
- Driven with an enclosed gear.
- All parts in contact with food are made of stainless steel.



Specifications

Model	Power (kW)	Voltage (V)	Capacity (L)	Bowl Diameter (mm)	Output (kg/h)	Net Weight (kg)	Dimensions (mm)
QS630	2.2/2.8	380	30	700	500	318	990x810x980
QS650	2.2/2.8	380	30	700	1000	360	1200x1000x1138

Ingredient Mixing Machine

Features

- Outer and bowl are made of stainlesssteel 201
- A machine for the professional, busy butcher or farm shop.
- Blender rotate quickly to ensure uniform blending.
- All the Works smoothly and at low noise contacting the food directly are made of stainless steel.
- With the four wheels, it is convenient to move.
- Working smoothly and low noise.



Interior Structure



Specifications

Model	Voltage (V)	Power (kW)	Production Capacity (L)	Net Weight (kg)	Dimension (mm)
BX35A	220	0.75	35	136	700x510x1100
BX50A	220	1.1	50	152	820x510x1100
BX70A	220	1.5	70	178	850x500x1100

Commercial Potato Peeler

Features

- This heavy duty stainless steel potato peeler was built for speed and durability, making it a powerful ally in situations in which potato peeling is a priority.
- **Non Slip Rubber Feet**
The potato peeler comes with unyielding non slip rubber feet so it remains steadfast during high intensity potato peeling sessions.
- **Stainless Steel Body**
The structure is built to be durable with quality grade stainless steel making it ideal for use in restaurants, hotels and other commercial environments.
- **High Speed**
This machine makes quick work of potatoes, with an average 8kg peeling time of only 2-3 minutes.

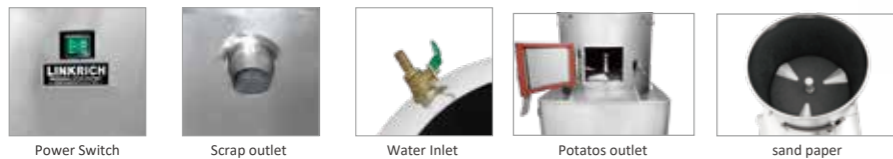
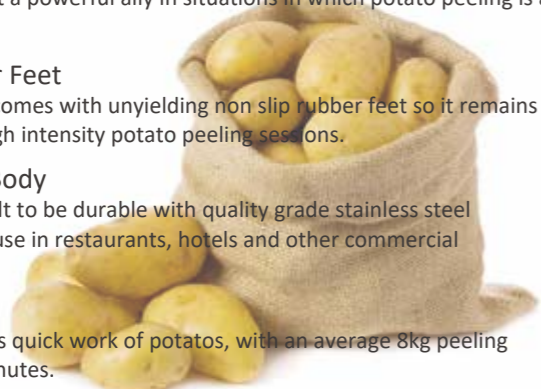

Specifications

Model	Power (kW)	Voltage (V)	Production Capacity (Kg/h)	Capacity (L)	Net Weight (kg)	Dimensions (mm)
PP-8C	0.55	220	240-480	10	42	460x460x785
PP-15C	0.75	220	480-900	15	53	520x520x850
PP-30C	1.5	380	1080-2160	30	72	600x580x1020

Commercial Potato Peeler

Features

- Potato Peeler is the new product developed and designed with the imported advanced foreign technology.
- It is suitable for the round or oval vegetable and fruits such as ginger, carrot, potatoes cleaning and peeling.
- It is with the fine appearance, easy to operate and clean, high efficiency, low consumption and long using life.
- The barrel and the body of the machine are made of good stainless steel, not rust, it can meet the health standards.
- It is supplied with filter system, can be more environmental friendly.



Specifications

Model	Power (kW)	Voltage (V)	Production Capacity (Kg/h)	Capacity (Kg)	Net Weight (kg)	Dimensions (mm)
PP-6D	0.37	220	100-240	6	38	635x360x880
PP-10D	0.55	220	240-480	10	50	685x410x960
PP-15D	0.75	220	480-900	15	62	715x440x1030
PP-6DE	0.37	220	100-240	6	30	635x360x750
PP-10DE	0.55	220	240-480	10	50	685x410x830
PP-150DE	0.75	220	480-900	15	62	715x440x900

Manual Potato Cutter

- The machine adopts a stainless steel, aluminium and steel structure, giving it a high corrosion resistance and high strength.
- The stainless steel blade and aluminium alloy tool both have a long service life.
- The structure of the handle makes for comfortable operation.
- The size of the product is completely consistent when a piece of raw material is placed one at a time.
- Production efficiency is over 10 times greater than manual processing.



Specifications

Model	Material	Specification(mm)
A150	Aluminium Alloy	7x7/9x9/14x14
S150	Stainless Steel	7x7/9x9/14x14

FDM Soybean Grinder

Features

- Possesses a high thermal efficiency, with an automatic separation of the juicer-residue, making it easy to operate.
- The shell stretch-formed by stainless steel with elegant appearance.
- First low voltage start up.
- High quality electric elements, safe, reliable, practical.

Specifications

Model	Voltage (V)	Power (kW)	Frequency (Hz)	Output (kg/h)	Net Weight (kg)	Dimensions (mm)
FDM-100	220	0.75	50	35	25	330x290x660
FDM-125	220	1.5	50	80	33	375x335x710
FDM-150	220	2.2	50	150	45	445x390x785



Spice Grinder

Features

- High Speed Powdering & pulverizing from 200g - 1.25 kg/h
- For industries such as herbal and pharmaceutical, foodstuff, agricultural, fishery, feed, cosmetic, chemical material, powder paint and laboratories or wherever dried products such as grains, grasses, herb, spices, mineral ores, feed & etc. need processing.



Specifications

Model	Voltage (V)	Power (kW)	Speed (r/min)	Net weight (kg)	Dimensions (mm)
WF-04A	220	1.2	28000	4	168x168x390
WF-10B	220	2	25000	7.5	216x216x395
WF-20B	220	3	25000	8.5	236x236x415
WF-25B	220	3.5	25000	8.5	236x236x425
LR1500	220	1.5	1500	47.5	730x330x340
LR2200	220	2.2	1500	49.5	730x330x340
LR3000	220	3.0	1500	58.5	730x360x380
LR3600	220	3.6	1500	68	765x365x410

Vacuum Sealing Machine

Product Description

- This commercial grade stainless steel vacuum sealing machine is suitable for sealing meat, vegetables, fruit, condiments, medicine etc.



The Ultimate Conservation

With this machine, both food & non food products can be protected from oxidation, mold and damp, allowing them to be stored for an extended period of time. Proper package is essential for increasing shelf life.

Industrial Strength Pump

Though compact, this machine uses an industrial strength pump (20m³/hr) that keeps products visible through the packaging so there'll be no surprises.

Stainless Steel Body

The structure is built to be durable, with quality grade stainless steel fascia making it ideal for use in restaurants, hotels and other commercial environments.

Fast Sealing Time

The 400mm long sealing bars ensure that almost any types of bags fit in the machine, substantially reducing the time of all future packing endeavours.



DZ-500



DZQ-500



DZQ-5002SA

Single Chamber Vacuum Packer

Model	Voltage (V)	Power (W)	Heat-sealing Power(kW)	Volume Of Vacuum Case(mm)	Sealing Strip Size(mm)	Exhaustment Of Vacuum Pump(m ³ /h)	Net Weight (kg)	Dimensions (mm)
DZ-400	220	900	1.3/1.75	420x435x70	400x10	20	65	540x490x550
DZ-500	220	900	2.0/2.7	530x530x70	500x10	20	72	650x585x565
DZ(Q)-400	220	900	1.3/1.75	420x435x70	400x10	20	80	540x490x940
DZ(Q)-500	220	900	2.0/2.7	530x530x70	500x10	20	105	650x585x980
DZ(Q)-600	220	900x2	2.0/2.7	630x630x95	600x10	20	125	760x710x1000

Double Chamber Vacuum Packer

Model	Voltage (V)	Pump Power(kW)	Chamber size (mm)	Sealing Length (mm)	Pump Capacity (m ³ /h)	Net Weight (kg)	Dimensions (mm)
DZQ-4002SA	220	1.2	453x471x50	400x10	20	180	1025x630x907
DZQ-5002SA	220	2.4	587x541x50	500x10	40	235	1254x703x937
DZQ-6002SA	220	2.4	670x552x50	600x10	40	300	1460x703x938

Mini Deck Oven

Features

- Knob type temperature control
- The whole stone plate design makes the food heated evenly.
- The body is made of stainless steel plate, and the double-layer toughened glass window is convenient to master the baking condition.



LR-EP-1



LR-EP-2

Specifications

Model	Specification	Voltage (V)	Power (kW)	Temperature (°C)	Net Weight (kg)	Pizza Ceramic Plate(mm)	Dimensions (mm)
LR-EP-1	One-layer One-tray	110	1.4	0~300	18.6	400x400	560x550x260
LR-EP-2	Two-layers Two-trays	110	2.1	0~300	25.3	400x400	560x570x440

Electric Pizza Oven

Features

- Top and bottom heat is controlled by the most accurate electronics
- Superior insulation to keep the heat in&the outside cool
- An exceptional oven that is suitable for all types of baking
- Each deck is complete with timer for individual deck by deck control



LR-DBS-1



LR-DBS-2

Model	Voltage	Power	Specification	Tempt.range.	Net Weight	Chamber Size	Dimensions
LR-DBS-1	220V	4.2kW	4(12")pcs	85~450°C	60kg	720x730mm	1000x930x430mm
LR-DBS-2	380V	8.4kW	8(12")pcs	85~450°C	104kg	720x730mm	1000x930x750mm

Electric Pizza Oven

Features

- Top and bottom heat is controlled by the most accurate electronics
- Superior insulation to keep the heat in&the outside cool
- An exceptional oven that is suitable for all types of baking
- Each deck is complete with timer for individual deck by deck control



EP-2-1
EP-1-1



EP-2
EP-1

Model	Voltage	Power	Specification	Tempt.range.	Net Weight	Chamber Size	Dimensions
EP-2-1	380V	4.2kW	1 Layer (4x12"pcs)	30~500°C	68	610x610x140mm	910x820x430mm
EP-1-1	380V	7.2kW	1 Layer (6x12"pcs)	30~500°C	108	610x910x140mm	890x1125x430mm
EP-2	380V	8.4kW	2 Layers (8x12"pcs)	30~500°C	118	610x610x140mm	910x820x750mm
EP-1	380V	14.4kW	2 Layers (12x12"pcs)	30~500°C	154	610x910x140mm	890x1125x750mm

LINKRICH COMMERCIAL OVEN

Electric Conveyor Pizza Oven

Electric Conveyor Pizza Oven ⚡

Features

- Digital presentation of the transmission speed of the chain and the working also can be adjusted according to different need
- The transmission direction of the chain can be adjusted freely
- Two knobs independently control the transmission speed of the chain and lower heating element



Model	Voltage	Power	Temperature	Net Weight	Work Area	Dimensions
LR-EP-12	220-240V/50HZ	6.7kW	50-350°C	45kg	380X1000mm	1100X570X370
LR-EP-18	3N-380V/50HZ	10.3kW	50-350°C	65kg	530X1450mm	1560X750X370
LR-EP-18	3N-380V/50HZ	25.5kW	50-350°C	65kg	880X1800mm	2500X1070X460

Electric convection conveyor pizza oven ⚡

Features

- The oven baking is 3D hot air circulation and the baking temperature is stable, which can make the baked food color is uniform and nice.
- The oven is equipped with microcomputer intelligent memory controls, the oven can stop working automatically, it is energy saving.
- The oven adopts the imported electricity elements and the thermostat.
- The body uses the A grade oil grinds sand grain 430 stainless steel, the chains are using the food grade 304 stainless steel. The thickness of the material is 1.2-2.0mm.
- The oven equips with 304 stainless steel heating elements, the service life is up to 3000 hours.



Model	Specification	Voltage	Heat Power	Temperature	Net Weight	The size of conveyor belt	Work Area	Dimensions
LR-MEP-15H	15" 2-6min/pcs	220V	7.5kW	0~400°C	140kg	1120x400mm	500x400x80mm	1230x890x450mm
LR-MEP-18H	18" 2-6min/pcs	220V	12kW	0~400°C	160kg	1340x530mm	650x530x80mm	1440x1100x470mm
LR-MEP-24H	24" 2-6min/pcs	380V	19kW	0~400°C	190kg	1580x645mm	770x645x80mm	1690x1150x535mm
LR-MEP-32H	32" 2-6min/pcs	380V	24kW	0~400°C	250kg	2000x850mm	1010x850x80mm	2070x1435x720mm

LINKRICH COMMERCIAL OVEN

Gas Conveyor Pizza Oven



Gas Conveyor Pizza Oven GAS

Features

- The structure of the oven is completely made of stainless steel.
- Fast heating and even temperature.
- Transmission direction and speed of the chain is adjustable
- Top and bottom heating elements control individually.
- Equip with garbage collection pan.
- Max temperature: 400°C
- Baking time: 3-5 minutes
- Gas and electric models are available.



Model	Voltage	Power	Temperature	Net Weight	Workstation Dimension	Gas type	Dimensions
LR-GP-12	110V/220V	0.1kW	0~400°C	60kg	350X1000mm	LPG/NG	1260X840X520mm
LR-GP-18	110V/220V	0.1kW	0~400°C	80kg	500X1450mm	LPG/NG	1735X990X520mm
LR-GP-18	110V/220V	0.1kW	0~400°C	80kg	850X1800mm	LPG/NG	2250X1500X1100mm

Gas convection conveyor pizza oven GAS

Features

- The oven baking is 3D hot air circulation and the baking temperature is stable, which can make the baked food color is uniform and nice.
- The oven is equipped with microcomputer intelligent memory controls, the oven can stop working automatically, it is energy saving.
- The oven adopts the imported electricity elements and the thermostat.
- The body uses the A grade oil grinds sand grain 430 stainless steel, the chains are using the food grade 304 stainless steel. The thickness of the material is 1.2-2.0mm.
- The oven equips with 304 stainless steel heating elements, the service life is up to 3000 hours.



Model	Specification	Voltage	Heat Power	Temperature	Net Weight	The size of conveyor belt	Work Area	Dimensions
LR-MGP-15H	15" 2-6min/pcs	220V	10kW/h	0~400°C	150kg	1170x400mm	600x400x80mm	1270x900x450mm
LR-MGP-18H	18" 2-6min/pcs	220V	12kW/h	0~400°C	170kg	1390x530mm	700x530x80mm	1500x1040x490mm
LR-MGP-24H	24" 2-6min/pcs	220V	12kW/h	0~400°C	200kg	1580x645mm	770x645x80mm	1690x1150x535mm
LR-MGP-32H	32" 2-6min/pcs	220V	20kW/h	0~400°C	260kg	2000x850mm	1010x850x80mm	2070x1435x720mm

Electric Food Dehydrator

Features

- Unique domestic hot air circulation technology.
- The uniform hot air circulation solves the issue of external dryness and/or internal wetness where other fruit dryers on the market fail.
- It dries your product 30% faster than other existing brands.
- The large glass door design and stainless steel 304-layer mesh are made to national hygiene standards.

Computer board with timer

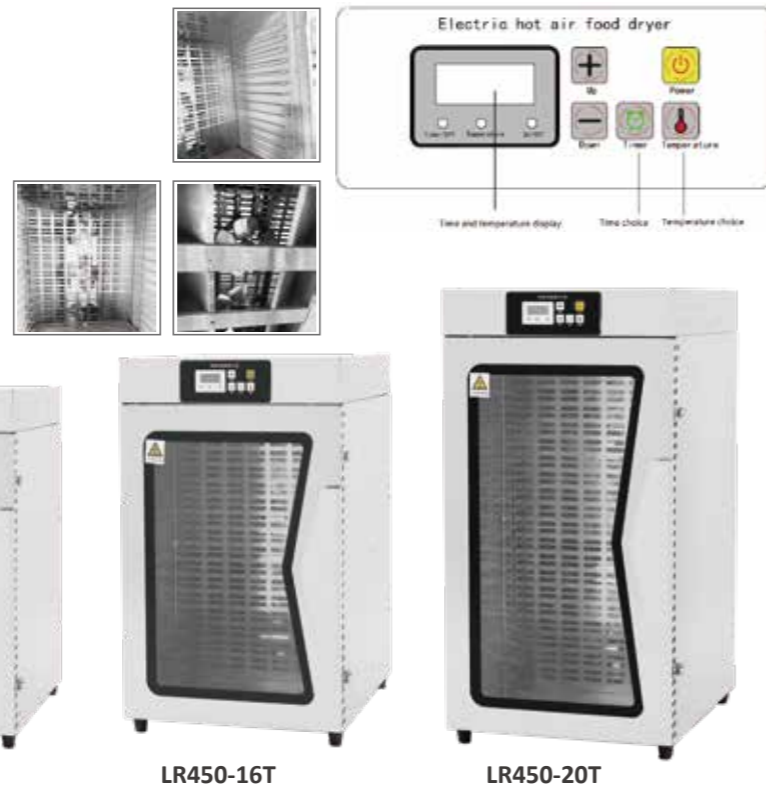

Specifications

Model	Capacity	Voltage (V)	Power (kW)	Drying Method	Max Temperature (°C)	Material	Net Weight (kg)	Dimensions (mm)
LR450-6T	6 trays	220	0.6	Hot wind	90	Stainless Steel	19	450x530x385
LR450-12T	12 trays	220	1	Hot wind	90	Stainless Steel	20	450x530x593
LR450-16T	16 trays	220	1.2	Hot wind	90	Stainless Steel	22	450x530x733
LR450-20T	20 trays	220	1.5	Hot wind	90	Stainless Steel	26.5	450x530x873

Electric Smoke House

Features

- Raw materials used :0.5 cm fruit wood particles, or fruit wood chips for smoking.
- Can be make a variety of ingredients such as: sausage/sausage/bacon/dried beans, etc



Specifications

Model	Voltage (V)	Power (kW)	Timer (H)	Inner layer height(cm)	Internal Dimensions(mm)	Net Weight (kg)	Dimensions (mm)
DSH-S03	110/220	1	0-12	9	400x340x690	22	450x400x790 +135chimney
DSH-S03L	110/220	1	0-12	9	400x340x1085	30	450x400x790 +135chimney

Convection Oven

Features

- 360°C hi-limit ensures safety operation
- Stainless steel cavity or ceramic coating cavity 120 minutes timer with bell
- Steel handle fixed by Bakelite base
- Dual round heaters plus two high speed motors Stainless steel baffle to generate heat more evenly Timing and heating indicators
- Good insulation at 5 sides
- Door latch opens at 90°for easy access to the cavity Level distance is 75mm
- Double toughened visual glass for better view and to keep cool to touch
- Manual steaming function is available for YXD-4A Grilling is perfect for finish of the cooked products



Specifications

Model	Description	Voltage (V)	Power (kW)	Temperature (°C)	Net Weight (kg)	Capacity	Dimensions (mm)
YXD-1A	Inner Chamber S/S	220	2.67	50~300	38	4x450x325mm Trays	595x530x570
YXD-1AE	Inner Chamber Enamel	220	2.67	50~300	38	4x450x325mm Trays	595x530x570
YXD-4A	Inner Chamber S/S, Spray	220	2.67	50~300	41	4x450x325mm Trays	595x530x570

Convection Oven

Features

- 62L capacity cavity 460x375x360 mm
- PCB control with programming function for 5 menus Easy conversion from program to manual(5-stages cooking)
- Cook & Hold, holding temperature at 65°C
- 360°C hi-limiter ensures safety operation
- Stainless steel cavity or ceramic coating cavity Precise timing function to seconds ,up to 99 minutes 59 seconds
- Chamber light for better view of cooking process Steel handle fixed by Bakelite base
- Dual round heaters plus two high speed motors Stainless steel baffle to generate heat more evenly Trip switch to stop working when door is opened Nickel coating pan support Four aluminum baking trays 325x450mm Optional wiring grid 325x450mm
- Good insulation at 5 sides
- Door latch opens at 90°for easy access to the cavity Level distance is 75mm
- Double toughened visual glass for better view and to keep cool to touch



Specifications

Model	Description	Voltage (V)	Power (kW)	Temperature (°C)	Net Weight (kg)	Capacity	Dimensions (mm)
YXD-1AD	Inner Chamber S/S	220	2.67	5~260	38	4x450x325mm Trays	595x530x570
YXD-1AED	Inner Chamber Enamel	220	2.67	5~260	38	4x450x325mm Trays	595x530x570
YXD-2AD	Inner Chamber S/S, Spray	220	2.67	5~260	38	4x450x325mm Trays	595x530x570
YXD-4AD	Inner Chamber S/S, Spray	220	2.67	5~260	41	4x450x325mm Trays	595x530x570

LINKRICH COMMERCIAL OVEN

Convection Oven

Convection Oven

Features

- Stainless steel structure Stainless steel heating elements Enameled cavity for easy cleaning 4 standard GN1/1 rack
- Bakelite handle
- Cook & Hold function
- Water proof switch



Specifications

Model	Description	Voltage (V)	Power (kW)	Temperature (°C)	Net Weight (kg)	Capacity	Dimensions (mm)
YXD-6A	Inner Chamber S/S, Spray	220	2.8	50~300	70	4 GN1/1 Pans	595x530x570

Convection Oven

Features

- 116L capacity cavity 700x460x360 mm
- 120 minutes timer with bell ● Steaming function
- 360°C hi-limiter ensures safety operation Stainless steel cavity or ceramic coating cavity Manual spraying switch for direct steam
- Chamber light for better view of cooking process Steel handle fixed by Bakelite base
- Dual round heaters plus two high speed motors Stainless steel baffle to generate heat more evenly Trip switch to stop working when door is opened Nickel coating pan support
- Four aluminum baking trays 600x400mm Optional wiring grid 600x400mm Good insulation at 5 sides
- Door latch opens at 90° for easy access to the cavity Level distance is 75mm
- Double toughened visual glass for better view and to keep cool to touch



Specifications

Model	Description	Voltage (V)	Power (kW)	Temperature (°C)	Net Weight (kg)	Capacity	Dimensions (mm)
YXD-8A	Inner Chamber S/S, Spray	220	6.4	50-300	67	4x400x600mm Trays	834x765x572

Convection Oven

Features

- Dual independent glass doors provide optimal visibility when shut, helping to keep the chamber temperature stable.
- Bakelite door handles are cool to the touch, avoiding user burns.
- 3 adjustable wire racks can be configured on 11 sets of slides along the interior side walls.
- Handy control panel complete with thermostatic controls, built-in timer, cook and cool modes, and adjustable fan speeds.
- Convenient interior light controlled by an exterior rocker switch.
- Stainless steel construction with porcelain interior floor to withstand regular use in busy commercial kitchens.
- A Full-size cavity ranges in temperature from 50~300 C to bake or hold the product.



Model	Description	Voltage (V)	Total input (btu/hr)	Power (kW)	Temperature (°C)	Net Weight (kg)	No. of Tray	Dimensions (mm)
FGC-100	Gas	220	54000	0.8	50~300	185	13	967x1099x1384
FEC-100	Electric	380	-	12.4	50~300	180	11	967x1099x1384

LINKRICH COMMERCIAL OVEN

Convection Oven

Convection Oven

Features

- Equipped with two timers, one for baking, the other for steaming.
- The inside and outside of the oven area all constructed from stainless steel, with a heat-resistant glass door with silica-gel air-proof gasket.
- The oven is also equipped with two fans (for 8 trays), baking is optimized thanks to the perfect heating system and the possibility of spraying steam as needed.
- Easily taken down door which makes for easy cleaning.
- Air convection ,fast baking
- Powerful steam
- Gas convection oven can hold from 1 tray to 3 trays ,5 trays, 8trays and 10 trays, tray size:400*600mm
- Adjustable steaming time, good for french baguette



LR-5D



LR-8D
LR-10D



LR-5Q



LR-8Q
LR-10Q



Electric Convection Oven

Model	Voltage (V)	Power (kW)	Temperature (°C)	Distance (mm)	Capacity	Net Weight (kg)	Dimensions (mm)
LR-5D	380	7.5	50-300°C	100	5 trays, 400x600mm	150	900x1275x850
LR-8D	380	15	50-300°C	100	8 trays, 400x600mm	214	900x1285x1180
LR-10D	380	19	50-300°C	100	10 trays, 460x720mm	220	960x1410x1340

Gas Convection Oven

Model	Voltage (V)	Power (kW)	Temperature (°C)	Distance (mm)	Capacity	Net Weight (kg)	Dimensions (mm)
LR-5Q	220	0.55	50-300°C	100	5 trays, 400x600mm	175	970x1330x1090
LR-8Q	220	0.75	50-300°C	100	8 trays, 400x600mm	255	970x1340x1480
LR-10Q	380	0.8	50-300°C	100	10 trays, 400x600mm	280	900x1250x1300

Convection Oven

Features

- The whole machine adopts the assembled structure, the production of the imported stainless steel plate material, and the standard apparatus. The blast type forced hot air circulation system is heated which greatly improves the heat transfer efficiency, shortens the heating time, so as to save energy.
- Air regulation and humidity equipment are used in the hot air outlet to produce the optimal temperature optimal for making grilled foods taste better
- Beautiful and luxurious appearance, functional, small size, low energy consumption, high output, baking uniform and each layer can be adjusted



EFC-6A



EFC-12A

Electric Convection Oven		Voltage (V)	Power (kW)	Temperature (°C)	Net Weight (kg)	Chamber Size (mm)	Dimensions (mm)
EFC-6A	Six-layers Six-trays	380	7.55	20~400	150	700x480x580	1230x900x730
EFC-12A	Twelve-layers Twelve-trays	380	16	20~400	230	700x480x1150	1230x900x1280

Convection Oven

Features

- Adopt the Europe-style outer design, beautiful and good-looking.
- Use the hot blast circulation to heat oven to keep the temperature risen evenly and quickly.
- The bottom and top fire can be set at will between 0°C~ 300°C.
- The oven will keep the constant temperature automatically.



RCO-5



RCO-10

Electric Convection Oven		Voltage (V)	Power (kW)	Net Weight (kg)	Tray Size (mm)	Chamber Size (mm)	Dimensions (mm)
RCO-5	One-layer Five-layers	380	9	198	605x410x35	470x600x700	980x1020x950
RCO-10	Two-layers Ten-layers	380	18	250	604x410x35	470x600x700	980x1020x1875



Signature Deck Oven

Features

- 400x600mm trays included.
- Glasses door windows,light inside each deck.
- Temperature in the 20-400°C adjustable,points underside fire,automatic constant temperature.
- With accurate digital controls for top&bottom element.
- Extremely well insulated.
- Fast heating,uniform furnace temperature,high thermal efficiency
- The furnace bottom for slab,heated evenly.

TECHNICAL DRAWING

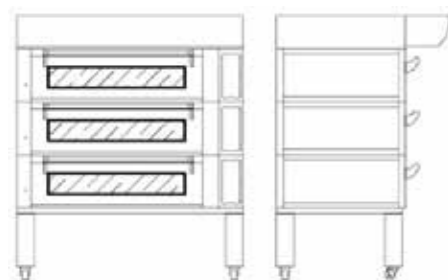

COMMERCIAL OVEN Signature Deck Oven

LINKRICH



LR-ES-12





LR-ES-24



LR-ES-36

Electric Signature Deck Oven

Model	Specification	Voltage	Power	Temperature	Net Weight	Chamber Size	Dimensions	Tray Layout
LR-ES-12	One-layer Two-trays	220V	6.6kW	20~400°C	66kg	870x650X220mm	1220x840x630mm	
LR-ES-24	Two-layers Four-trays	380V	13kW	20~400°C	129kg	870x650X220mm	1220x840x1330mm	
LR-ES-36	Three-layers Six-trays	380V	19.8kW	20~400°C	178kg	870x650X220mm	1220x840x1700mm	



LR-ES-13



LR-ES-26







LR-ES-39



LR-ES-312
LR-ES-416

Electric Signature Deck Oven

Model	Specification	Voltage	Power	Temperature	Net Weight	Chamber Size	Dimensions	Tray Layout
LR-ES-13	One-layer Three-trays	380V	8.4kW	20~400°C	87kg	1290x650X220mm	1640x840x630mm	
LR-ES-26	Two-layers Six-trays	380V	16.8kW	20~400°C	165kg	1290x650X220mm	1640x840x1330mm	
LR-ES-39	Three-layers Nine-trays	380V	25.2kW	20~400°C	227kg	1290x650X220mm	1640x840x1700mm	
LR-ES-312	Three-layers Twelve-trays	380V	30kW	20~400°C	276kg	1290x870x220mm	1640x1060x1700mm	
LR-ES-416	Four-layers Sixteen-trays	380V	36kW	20~400°C	410kg	1290x870x220mm	1640x1060x1920mm	



Signature Deck Oven

Features

- 400x600mm trays included.
- Glasses door windows, light inside each deck.
- Temperature in the 20-400°C adjustable, points underside fire, automatic constant temperature.
- With accurate digital controls for top & bottom element.
- Extremely well insulated.
- Fast heating, uniform furnace temperature, high thermal efficiency
- The furnace bottom for slab, heated evenly.



TECHNICAL DRAWING

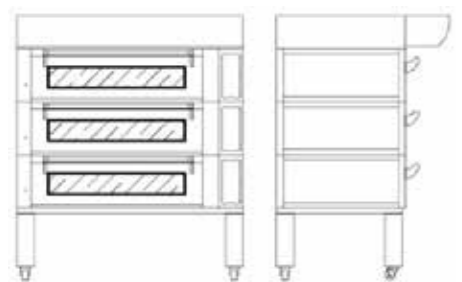

COMMERCIAL OVEN **LINKRICH** Signature Deck Oven



LR-GS-12





LR-GS-24



LR-GS-36

Gas Signature Deck Oven

Model	Specification	Voltage	Power	Temperature	Net Weight	Chamber Size	Dimensions	Tray Layout
LR-GS-12	One-layer Two-trays	220V	0.06kW	20~400°C	95kg	870x650x220mm	1310x910x650mm	
LR-GS-24	Two-layers Four-trays	220V	0.12kW	20~400°C	168kg	870x650x220mm	1310x910x1500mm	
LR-GS-36	Three-layers Six-trays	220V	0.18kW	20~400°C	220kg	870x650x220mm	1310x910x1700mm	



LR-GS-13



LR-GS-26







LR-GS-39



LR-GS-312
LR-GS-416

Gas Signature Deck Oven

Model	Specification	Voltage	Power	Temperature	Net Weight	Chamber Size	Dimensions	Tray Layout
LR-GS-13	One-layer Three-trays	220V	0.06kW	20~400°C	158kg	1290x650x220mm	1730x910x650mm	
LR-GS-26	Two-layers Six-trays	220V	0.12kW	20~400°C	220kg	1290x650x220mm	1730x910x1500mm	
LR-GS-39	Three-layers Nine-trays	220V	0.18kW	20~400°C	300kg	1290x650x220mm	1730x910x1730mm	
LR-GS-312	Three-layers twelve-trays	220V	0.18kW	20~400°C	380kg	1290x870x220mm	1730x1130x1730mm	
LR-GS-416	Four-layers Sixteen-trays	220V	0.24kW	20~400°C	500kg	1290x870x220mm	1730x1130x2180mm	



Signature Deck Oven

Features

- 400x600mm trays included.
- Glasses door windows,light inside each deck.
- Temperature in the 20-400°C adjustable,points underside fire,automatic constant temperature.
- With accurate digital controls for top&bottom element.
- Extremely well insulated.
- Fast heating,uniform furnace temperature,high thermal efficiency
- The furnace bottom for slab,heated evenly.



COMMERCIAL OVEN Signature Deck Oven

LINKRICH



Electric Signature Deck Oven

Model	Specification	Voltage	Power	Temperature	Net Weight	Chamber Size	Dimensions	Tray Layout
LR-ES-1	One-layer One-tray	220V	3.2kW	20~400°C	33kg	618x518x220mm	850x640x450mm	
LR-ES-2	Two-layers Two-trays	220V	6.4kW	20~400°C	66kg	618x518x220mm	850x640x800mm	
LR-ES-3	Three-layers Three-trays	220V	9.6kW	20~400°C	100kg	618x518x220mm	850x640x1100mm	



Gas Signature Deck Oven

Model	Specification	Voltage	Power	Temperature	Net Weight	Chamber Size	Dimensions	Tray Layout
LR-GS-1	One-layer One-tray	220V	0.06kW	20~400°C	55kg	650x520x220mm	990x730x530mm	
LR-GS-2	Two-layers Two-trays	220V	0.12kW	20~400°C	92kg	650x520x220mm	990x730x1100mm	
LR-GS-3	Three-layers Three-trays	220V	0.18kW	20~400°C	148kg	650x520x220mm	990x730x1600mm	



Stainless Steel Oven With Proofer

Features

- The oven is equipped with a combined oven , with detachable upper and lower layers and independent control system.
- Infrared heating tube, reasonable heat distribution,high gas thermal efficiency and low gas consumption,independent temperature control of upper and lower fire.
- The body its made of stianless steel and double-layer toughened glass window.
- Hot air circulation technology in the box,uniform temperature and humidity environment,convenient control of fermentation by glass window.



COMMERCIAL OVEN

Stainless Steel Oven with Proofer

LINKRICH



LR-102DF



LR-204DF



LR-102QF



LR-204QF

Electric Oven With Proofer



Model	Specification	Voltage (V)	Power (kW)	Temperature (°C)	Net Weight (kg)	Chamber Size (mm)	Dimensions (mm)
LR-102DF	One Layer Two Trays Oven 10 Trays Proofer	220/380	9.4	0~400 for Oven 0~110 for Proofer	-	400x600	1220x810x1470
LR-204DF	Two Layers Four Trays Oven 10 Trays Proofer	380	16	0~400 for Oven 0~110 for Proofer	-	400x600	1220x800x1880

Gas Oven With Proofer



Model	Specification	Voltage (V)	Power (kW)	Gas Type	Temperature (°C)	Net Weight (kg)	Chamber Size (mm)	Dimensions (mm)
LR-102QF	One Layer Two Trays Oven 10 Trays Proofer	220	2.8	LPG/NG	0~400 for Oven 0~110 for Proofer	-	400x600	1340x900x1620
LR-204QF	Two Layers Four Trays Oven 10 Trays Proofer	220	2.8	LPG/NG	0~400 for Oven 0~110 for Proofer	-	400x600	1340x900x2120



Stainless Steel Oven

Features Temperature 0~400°C

- Artistic appearance, suitable for shopping malls, supermarkets, hotel, fresh baking shop to bake all kinds of products
- All outside in stainless steel. Using intelligent dual display temperature control system, the temperature error is small, the failure rate is low.
- Oven door with high temperature door seal, to avoid the phenomenon of leakage, to enhance the oven insulation performance, the use of chain drive, to avoid the spring often break.
- Each layer up and down of fire alone control, with a timer alarm function, simple operation.
- Unique increased chamber design, baked products more uniform.
- Lava stone and steam device are customized.



COMMERCIAL OVEN Stainless Steel Oven

LINKRICH



Electric Stainless Steel Oven



Model	Specification	Voltage (V)	Power (kW)	Net Weight (kg)	Tray Size (mm)	Chamber Size (mm)	Dimensions (mm)	Tray Layout
LR-20D	One-layer Two-trays	220	6.6	78	600x400	870x670x220	1280x875x575	■ ■
LR-40D	Two-layers Four-trays	380	13.2	149	600x400	870x670x220	1280x875x1245	■ ■
LR-60D	Three-layers Six-trays	380	19.8	200	600x400	870x670x220	1280x875x1640	■ ■
LR-90D	Three-layers Nine-trays	380	24	275	600x400	1290x670x220	1700x875x1640	■ ■ ■



Gas Stainless Steel Oven



Model	Specification	Voltage (V)	Power (kW)	Net Weight (kg)	Tray Size (mm)	Chamber Size (mm)	Dimensions (mm)	Tray Layout
LR-20R	One-layer Two-trays	220	0.1	115	600x400	910x715x230	1340x990x700	■ ■
LR-40R	Two-layers Four-trays	220	0.2	210	600x400	910x715x230	1340x990x1357	■ ■
LR-60R	Three-layers Six-trays	220	0.3	285	600x400	910x715x230	1340x990x1777	■ ■
LR-90R	Three-layers Nine-trays	220	0.3	390	600x400	1330x715x230	1760x990x1777	■ ■ ■



Professional Digital Stainless Steel Oven

Features (Temperature:0~300°C)

- Microcomputer control and touch panel
- Temperatures of bottom fire and surface fire can be set at a range of room temperature ~300°C as required
- The oven keeps the temperatures at constant automatically
- Easy to operate. Working reliably
- The equipped steam generator system ensures the food surface with a right humidity
- The oven uses superior quality distant infrared radiant heating tube to heat the materials rapidly and uniformly. It is in conformity with national food hygiene standard
- The ultra-high temperature protection system ensures the oven working in safety
- Built-in lamp and glass window make it easier to observe the baking process
- Elegant style design meets the western European trends



COMMERCIAL OVEN Professional Digital Stainless Steel Oven

LINKRICH



PEO-2

PEO-4

PEO-6

Professional Digital Electric Stainless Steel Oven



Model	Specification	Voltage (V)	Power (kW)	Temperature (°C)	Net Weight (kg)	Tray Size (mm)	Chamber Size (mm)	Dimensions (mm)	Tray Layout
PEO-2	One-layer Two-trays	220	8	0~300	110	600x400	865x655x225	1355x930x730	■ ■
PEO-4	Two-layers Four-trays	380	16	0~300	200	600x400	865x655x225	1355x930x1260	■ ■
PEO-6	Three-layers Six-trays	380	24	0~300	290	600x400	865x655x225	1355x930x1650	■ ■



GFO-2C

GFO-4C

GFO-6C

Professional Digital Gas Stainless Steel Oven



Model	Specification	Voltage (V)	Heat Load (MJ/h)	Net Weight (kg)	Tray Size (mm)	Chamber Size (mm)	Dimensions (mm)	Tray Layout
GFO-2C	One-layer Two-trays	220	45	185	600x400	865x655x225	1355x960x720	■ ■
GFO-4C	Two-layers Four-trays	220	90	300	600x400	865x655x225	1355x960x1375	■ ■
GFO-6C	Three-layers Six-trays	220	135	400	600x400	865x655x225	1355x960x1835	■ ■



Professional Digital Stainless Steel Oven

Features

- Stainless Steel Material--The Body its made of stainless steel and equipped with all glass windows.which is convenient to master the baking condition.
- Electric Heating Control System--The black titanium series customized for different user groups,matching different decotation styles, is more corrosion-resistant and high-temperature than ordinary SS.
- Electric Oven--Far infrared electric heating tube its used to radiate and heat evenly.
- Gas Control System--Furnace surface,bottom temperature independent control,microcomputer pulse ignition and flame monitoring system,high ignition rate,accidental flameout or flameout,automatic alarm.
- Gas Oven--Baking heating tube has hihg combustion he and low air consumption.
- High flow steam ,Heating tube and stone its opertional.



COMMERCIAL OVEN Professional Digital Stainless Steel Oven

LINKRICH



LR-102DHA

LR-204DHA

LR-306DHA

Professional Digital Electric Stainless Steel Oven



Model	Specification	Voltage (V)	Power (kW)	Temperature (°C)	Tray Size (mm)	Chamber Size (mm)	Dimensions (mm)	Tray Layout
LR-102DHA	One Layer Two Trays	220/380	6.6	20~400	600x400	870x650x230	1220x900x590	■ ■
LR-204DHA	Two Layers Four Trays	380	13.2	20~400	600x400	870x650x230	1220x900x1250	■ ■
LR-306DHA	Three Layers Six Trays	380	19.8	20~400	600x400	870x650x230	1220x900x1640	■ ■



LR-102QHA

LR-204QHA

LR-306QHA

Professional Digital Gas Stainless Steel Oven



Model	Specification	Voltage (V)	Gas Type	Temperature (°C)	Tray Size (mm)	Chamber Size (mm)	Dimensions (mm)	Tray Layout
LR-102QHA	One Layer Two Trays	220	LPG/NG	20~400	600x400	890x695x220	1340x990x680	■ ■
LR-204QHA	Two Layers Four Trays	220	LPG/NG	20~400	600x400	890x695x220	1340x990x1320	■ ■
LR-306QHA	Three Layers Six Trays	220	LPG/NG	20~400	600x400	890x695x220	1340x990x1810	■ ■



Professional Digital Stainless Steel Oven

Features

- **Stainless Steel Material**--The whole machine is made of stainless steel.The inner tank can be customized with stainless steel or aluminum plating.
- **Uniform Heat Transfer**--9 stainless steel heating tubes are arranged at the top and bottom to make the heat transfer evenly from top to bottom,and the baking effect is even and stable.
- **Energy Saving**--Good thermal insulation technology makes the heat in the oven not easy to lose. When the equipment is running, the power peak value is coordinated through the performance control system planning to achieve the effect of energy saving and power saving.
- **Portability**--Equipped with universal wheel tripod, with brake design, easy to push and fix.
- **Intelligent Control Panel**--The intelligent control panel with clear structure is used to control up and down fire/baking time/steam/lighting.It is equipped with high-speed cup chip, with standby insulation system, steam blocking system and machine cooling system.
- The Intelligent Control Panel come with 32 groups of fast data storage,Over Temp Power-Off protection,Automatic alarm when the environment is higher than 75℃ and Standby insulation system.

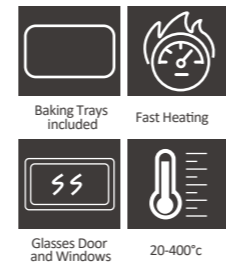

COMMERCIAL OVEN

LINKRICH

Professional Digital Stainless Steel Oven



Professional Digital Electric Stainless Steel Oven

Model	Specification	Voltage (V)	Power (kW)	Temperature (°C)	Tray Size (mm)	Chamber Size (mm)	Dimensions (mm)	Tray Layout
LR-102DS	One Layer Two Trays	380	10.8	20~400	600x400	870x760x220	1300x1150x720	■ ■
LR-204DS	Two Layers Four Trays	380	21.6	20~400	600x400	870x760x220	1300x1150x1390	■ ■
LR-306DS	Three Layers Six Trays	380	32.4	20~400	600x400	870x760x220	1300x1150x1890	■ ■
LR-103DS	One Layer Three Trays	380	11.3	20~400	600x400	1305x760x220	1760x1150x720	■ ■ ■
LR-206DS	Two Layers Six Trays	380	22.6	20~400	600x400	1305x760x220	1760x1150x1485	■ ■ ■
LR-309DS	Three Layers Nine Trays	380	33.9	20~400	600x400	1305x760x220	1760x1150x2030	■ ■ ■



Professional Digital Gas Stainless Steel Oven

Model	Specification	Voltage (V)	Gas Type	Temperature (°C)	Tray Size (mm)	Chamber Size (mm)	Dimensions (mm)	Tray Layout
LR-102QS	One Layer Two Trays	220	LPG/NG	20~400	600x400	860x730x200	1300x1170x720	■ ■
LR-204QS	Two Layers Four Trays	220	LPG/NG	20~400	600x400	860x730x200	1300x1170x1490	■ ■
LR-306QS	Three Layers Six Trays	220	LPG/NG	20~400	600x400	860x730x200	1300x1170x2040	■ ■
LR-103QS	One Layer Three Trays	220	LPG/NG	20~400	600x400	1300x730x200	1760x1140x720	■ ■ ■
LR-206QS	Two Layers Six Trays	220	LPG/NG	20~400	600x400	1300x730x200	1760x1170x1490	■ ■ ■
LR-309QS	Three Layers Nine Trays	220	LPG/NG	20~400	600x400	1300x730x200	1760x1170x2040	■ ■ ■



Rotary Convection Oven

Features

- Providing processing service, catering customers power supplying condition oil type, gas type, and electric types.
- The burning mechanism is imported from Japan and feature complete burning, and low exhaust emission saving energy and lowering the producing cost.
- The electric parts apply imported components.
- Reasonable structure design beautiful appearance, simple and reliable.

Product advantage:

- The door double-layer tempered glass door, removable cleaning, simple and convenient.
- Five-stage style tuyere, facilitate adjustment, furnace temperature.
- The oven is removable structure, conveniently to transport and install.
- With the exhaust system.
- With the steam function can be baking the french baguette.



COMMERCIAL OVEN Rotary Convection Oven

LINKRICH



LR-16D/LR-32D
LR-16C/LR-32C
LR-16G/LR-32G



LR-32D / LR-64D
LR-32C / LR-64C
LR-32G / LR-64G

Electric Rotary Convection Oven

Model	Description	Voltage (V)	Power (kW)	Temperature (°C)	Net Weight (kg)	Tray Size (mm)	Dimensions (mm)
LR-16D	Electric, 16 Trays	380	37	0~300	1600	400x600	1330x2190x2450
LR-32D	Electric, 32 Trays	380	46	0~300	1800	400x600	1550x2360x2450
LR-64D	Electric, 64 Trays	380	68.5	0~300	3200	400x600	2050x2850x2450

Diesel Rotary Convection Oven

Model	Description	Voltage (V)	Power (kW)	Temperature (°C)	Net Weight (kg)	Chamber Size (mm)	Dimensions (mm)
LR-16C	Diesel, 16 Trays	380	3.2	0~300	1600	400x600	1330x2190x2450
LR-32C	Diesel, 32 Trays	380	3.2	0~300	1800	400x600	1550x2360x2450
LR-64C	Diesel, 64 Trays	380	4.5	0~300	3200	400x600	2050x2850x2450

Gas Rotary Convection Oven

Model	Description	Voltage (V)	Power (kW)	Temperature (°C)	Net Weight (kg)	Chamber Size (mm)	Dimensions (mm)
LR-16G	Gas, 16 Trays	380	3.2	0~300	1600	400x600	1330x2190x2450
LR-32G	Gas, 32 Trays	380	3.2	0~300	1800	400x600	1550x2360x2450
LR-64G	Gas, 64 Trays	380	4.5	0~300	3200	400x600	2050x2850x2450



Gas Tunnel Furnace

The gas tunnel furnace has the advantages of a large output and high speed, and can be also be configured into an assembly line operation. The upper and lower flames are controlled separately allowing for even baking and the speed can be adjusted to suit different baking requirements. This oven utilises a centralized air supply and a mixed combustion process. This means it does not require constant re-ignition which not only saves energy, but also provides for a more uniform baking process and better tasting final product. The main electrical components are made in France while the temperature control instrument is made in Taiwan. These controls provide for precise temperature management and reliability. The oven can also be equipped with a PLC control system, and fully braked in and out conveyor lines to automate the whole production process. Baking range: suitable for cakes, breads, toast, mooncakes, French sticks and other kinds of breads and snacks.



Product advantages:

- The special design solves the problem of traditional tunnel furnaces which often have uneven temperatures with high temperature on the sides and low temperatures in the middle.
- The use of German technology stainless steel mesh chain solves the problem of chain breakage caused by thermal expansion.
- The stainless steel shell and the hearth are made of food-grade aluminized plates, which have fast heat transfer and uniform heat reflection.
- The inner chamber and outer wall are separated by ceramic which saves energy by more than 25%.
- The inner chamber is equipped with a furnace residue cleaning device which can automatically clean the residue and keep the furnace clean and hygienic.
- The oven is equipped with a manual release device, so the product may be easily removed by hand in the event of a power outage.

Specifications

Model	Description	Voltage (V)	Power (kW/M)	Net Weight (kg)	Energy Consumption	Dimensions (mm)
BM-14QBL	2 trays infeed, chamber width: 1.4M	380	0.2	-	M*Hour*0.5m ³	(customize)x2300x1780
BM-20QBL	3 trays infeed, chamber width: 2M	380	0.4		M*Hour*0.75m ³	(customize)x2900x1780

Spray Proofer ⚡

Features

- Powerful,efficient even airflow heating system maintains the right combination of heat and humidity to properly ferment products.
- Power switch on the top,easy to operate.
- Full stainless steel body and strong insulation,more effective.



PO-12B
PO-14B



PO-24B
PO-28B



PO-16
PO-16S



PO-32
PO-32S

Electric Spray Proofer ⚡

Model	Specification	Voltage (V)	Power (kW)	Temperature (°C)	Humidity (%RH)	Net Weight (kg)	Tray Size (mm)	Dimensions (mm)
PO-12B	12 Trays Proofer Single Door	220	2.4	36~38	60~80	50	400x600	500x770x1600
PO-14B	14 Trays Proofer Single Door	220	2.4	36~38	60~80	65	400x600	500x770x1600
PO-24B	24 Trays Proofer Double Doors	220	2.5	36~38	60~80	85	400x600	1200x770x1600
PO-28B	28 Trays Proofer Double Doors	220	2.5	36~38	60~80	100	400x600	1200x770x1600
PO-16	16 Trays Proofer Single Door	220	2.45	30~110	60~80	45	400x600	500x730x1985
PO-16S	16 Trays Proofer Single Door, Spray	220	2.0	30~110	60~80	55	400x600	500x800x2045
PO-32	32 Trays Proofer Double Doors	220	3.2	30~110	60~80	83	400x600	1010x730x1985
PO-32S	32 Trays Proofer Double Doors, Spray	220	2.0	30~110	60~80	105	400x600	1010x800x2045

Spray Proofer ⚡

Features

- All outside in #201 Stainless Steel & inside in #304Stainless Steel, PU insulation layers
- Micro-computer touch panel,digital sensor and timer
- Automatic airflow circulation system.,water enter automatically
- Germany & Taiwan imported critical components.



Electric Spray Proofer ⚡

Model	Specification	Voltage (V)	Power (kW)	Net Weight (kg)	Chamber Size (mm)	Dimensions (mm)
LR-232S	2 trolleys, 64 Trays	220	2	340	400x600/460x720	1910x1380x2050
LR-432S	4 trolleys, 128Trays	220	4	380	400x600/460x720	1970x1660x2050
LR-632S	6 trolleys, 192 Trays	220	6	800	400x600/460x720	2740x2160x2050
LR-832S	8 trolleys, 256 Trays	220	8	1000	400x600/460x720	3080x1920x2050

Refrigerated Bread Fermentation & Water Cooling Machine

Spray Proofer ⚡ Features

- Microcomputer control panel, temperature and humidity time can be controlled, working state is clear, hot air circulation technology makes the air in the cabinet fast convection, uniform fermentation.
- Stainless steel high temperature resistant frame, convenient for mobile cleaning, visual glass can observe the whole process of dough fermentation



PO-32TC

PO-64TC

Electric Spray Proofer ⚡

Model	Specification	Voltage (V)	Power (kW)	Temperature (°C)	Humidity (%RH)	Net Weight (kg)	Chamber Size (mm)	Dimensions (mm)
PO-32TC	32 Trays Proofer Single Door	220	2.8	0~6	0~95	-	400x600	850x1100x2170
PO-64TC	64 Trays Proofer Double Doors	220	5.6	0~6	0~95	-	400x600	1700x1100x2170

Refrigerated Bread Fermentation

Features ⚡

- Delayed fermentation Automatic conversion
- The body is made of stainless steel, using imported compressor, electronic control panel, and the whole process of proofing is guided and controlled.
- The water consumption in 24 hours is about one bottle of mineral water. It is foamed with polyurethane material, and the foam thickness can reach 45mm.
- Automatic conversion to a refrigerated fermentation box, so you can say goodbye to the hassle of having to get up early every day to rise your dough.



LR-18
LR-24L...

LR-36DR

Model	Specification	Voltage (V)	Power (kW)	Refrigeration Temp(°C)	Freezing Temp(°C)	Proofer Temp(°C)	Humidity (%RH)	Net Weight (kg)	Tray Size (mm)	Dimensions (mm)
LR-18DR	18 Trays Proofer SingleDoor	220	1.7	2~5	0~-15	15~38	60~95	130	400x600	600x955x2100
LR-24DR	24 Trays Proofer SingleDoor	220	2.6	2~5	0~-15	15~38	60~95	123	400x600	780x1100x1680
LR-36DR	36 Trays Proofer SingleDoor	220	3.4	2~5	0~-15	15~38	60~95	176	400x600	800x1155x2100

Water Cooling Machine

Bread Food Factory Mist Water Cooling System Chilled Water System

- Water cooler, capacity 100L/hour or 200L/hour cooling from +18°C to +2°C
- Useful tank volume: 100L/200L
- With pump and water stirrer
- Overflow safety Electric mechanical control box
- Exterior and water tank are stainless steel



Specifications

Model	Voltage (V)	Power (kW)	Capacity (L)	Net Weight (kg)	Dimensions (mm)
HM-100	220	0.75	100	70	800x530x950
HM-200	220	1.5	200	150	800x600x1360

Rotary Rotisseries

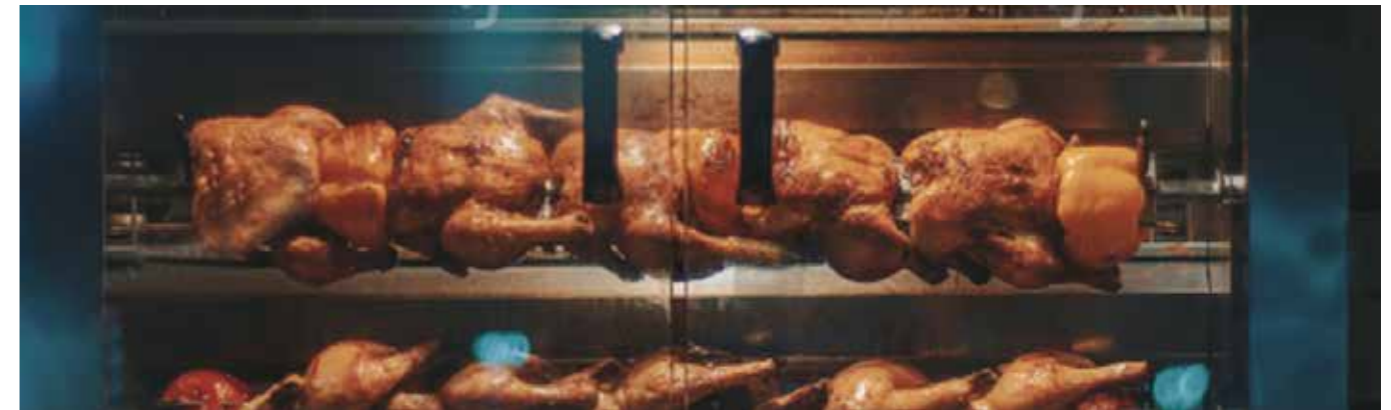

Rotary Rotisseries ⚡ GAS

Features

- Interior lighting
- Inside is completely removable for easy cleaning
- Easy thermostatically controlled
- Spit and basket interchangeable
- All stainless steel body
- High-performance burner to make a balance distribution of heat.
- Convenient to observe the roasting process and have good heat insulation, ensure good taste.



Specifications

Model	Specification	Voltage (V)	Power (kW)	Heat Power (kW)	Temperature (°C)	Net Weight (kg)	Dimensions (mm)
GT-3P	Gas, 12-15chickens	220	0.2	10	50~300	60	1180x490x710
ET-3P	Electrics, 12-15chickens	220	6	-	50~300	50	1180x490x710

Rotary Rotisseries ⚡ GAS

Features

- Interior lighting
- Inside is completely removable for easy cleaning
- Easy thermostatically controlled
- Spit and basket interchangeable
- All stainless steel body
- High-performance burner to make a balance distribution of heat.
- Convenient to observe the roasting process and have good heat insulation, ensure good taste.



Specifications

Model	Specification	Voltage (V)	Power (kW)	Heat Power (kW)	Temperature (°C)	Net Weight (kg)	Dimensions (mm)
GT-6P	Gas, 24-30chickens	220	0.3	20	50~300	85	1180x490x1250
GT-9P	Gas, 36-45chickens	220	0.4	30	50~300	115	1180x490x1780
ET-6P	Electrics, 24-30chickens	380	12.3	-	50~300	75	1180x490x1250
ET-9P	Electrics, 36-45chickens	380	18.4	-	50~300	105	1180x490x1780

Rotary Rotisseries Features



- Interior lighting
- Inside is completely removable for easy cleaning
- Easy thermostatically controlled
- Spit and basket interchangeable
- All stainless steel body
- High-performance burner to make a balance distribution of heat.
- Convenient to observe the roasting process and have good heat insulation,ensure good taste.



YXD-201
YXD-201-G

YXD-201-L

Specifications

Model	Specification	Voltage (V)	Power (kW)	Temperature (°C)	Net Weight (kg)	Dimensions (mm)
YXD-201	Electric, 24chickens	380	10	50~300	179	1000x900x1000
YXD-201-G	Gas, 24chickens	220	9	50~300	160	1000x900x1060
YXD-201-L	Electric, 48 chickens	380	10+10	50~300	353	1000x900x2140

Rotary Rotisseries Features



- Interior lighting
- Inside is completely removable for easy cleaning
- Easy thermostatically controlled
- Spit and basket interchangeable
- All stainless steel body
- Three sides visual heatproof glasses for good showing effect
- High-performance burner to make a balance distribution of heat.
- Convenient to observe the roasting process and have good heat insulation,ensure good taste.



Specifications

Model	Specification	Voltage (V)	Power (kW)	Temperature (°C)	Net Weight (kg)	Dimensions (mm)
YXD-306	Gas, 24 chickens	220	0.6	50~300	106	670x550x1580
YXD-206-L	Electric, 24 chickens	220	6.7	50~300	106	670x550x1580

Bread Toaster

Bread Toaster

Features

- Uniformly toasts regular bread, bagels, Texas toast, frozen waffles, and more
- Switchable bread and bagel controls provide perfect toasting results each time
- Able to hold 4 slices at once and toast up to 380 slices per hour
- Easily replaceable industrial heating plates



Model	Description	Voltage (V)	Power (kW)	Net Weight (kg)	Dimensions (mm)
ETS-4	4 Pieces Toaster	220	1.8	3.9	325x285x250
ETS-6	6 Pieces Toaster	220	3.9	5.5	460x285x250

Conveyor Bread Toaster

Features

For versatility, this toaster can dispense product from the front or back on the included chutes. This makes it great for either self-service breakfast bars or prep areas where you have multiple employees assembling sandwiches! To set this toaster up to operate *only from the front*, simply close the rear panel. This will direct the toast toward the bottom of the unit and out through the front chute

- Different conveyor speeds let you toast different items to perfection
- The wide conveyor can handle one to three pieces of toast or two bagel halves, side by side for different



Model	Voltage (V)	Power (kW)	Internal Size (mm)	Net Weight (kg)	Out put (pcs/h)	Dimensions (mm)
TT-150	220	1.34	170	14	150~180	288x418x387
TT-300	220	1.94	240	16	300~350	368x418x387
TT-450	220	2.64	360	20.5	450~500	468x418x387

Bread Toaster

Features

- Infrared quartz tube for prompt heating Temperature can reach maximum within 30 seconds Infrared heating efficiency is much better than regular heating
- Insulation on three sides(Top, Left, Right) Stainless steel crumb collector with handle Cooling down in seconds after switch is turned off Anti slippery rubber foot
- Mirror polished stainless steel structure
- Selective switch for different heating groups Wiring grid protection to protect quartz tube 15 minutes mechanical timer with bell
- Removable stainless steel crumb collector Optional tongs



Model	Description	Voltage (V)	Power (kW)	Net Weight (kg)	Dimensions (mm)
QT-1	Single Layer	220	1.7	7.8	440x300x290
QT-2	Double Layers	220	3	10.2	440x300x400

Salamander

Electric Salamander ⚡

Features

- Stainless steel construction
- Dual energy regulator control
- Dura-life stainless steel elements for prolonged element life
- Easy-clean crumb tray & reflector
- Ideal for grilling, top toasting and finishing off ingredients such as cheese, mornays and toppings
- High quality control system of heating, durable, quality assurance



Model	Voltage (V)	Power (kW)	Temperature (°C)	Net Weight (kg)	Dimensions (mm)
EB-450	220	2.8	50~300	38	450x520x500
EB-600	220	4	50~300	49	600x520x500
EB-800	220	5.6	50~300	63	800x520x500

Electric Salamander ⚡

Features

- Stainless steel construction
- Dual energy regulator control
- Dura-life stainless steel elements for prolonged element life
- Top heat source only
- Easy-clean crumb tray & reflector
- Ideal for grilling, top toasting and finishing off ingredients such as cheese, mornays and toppings
- High quality control system of heating, durable, quality assurance



Model	Voltage (V)	Power (kW)	Temperature (°C)	Net Weight (kg)	Chamber Size (mm)	Dimensions (mm)
AT-936	220	2	0~300	12	455x260x155	615x305x280
AT-938	220	2.2	0~300	12	415x340x255	580x375x380
AT-937	220	4	0~300	26	635x400x365	790x455x490

Gas Salamander GAS

Features

- Stainless steel construction
- Dual energy regulator control
- Top heat source only
- Easy-clean crumb tray & reflector
- Ideal for grilling, top toasting and finishing off ingredients such as cheese, mornays and toppings
- High quality control system of heating, durable, quality assurance



Model	Heat Power (BTU/h)	Net Weight (kg)	Chamber Size (mm)	Dimensions (mm)
RG-14	23884	32	440x380x290	620x440x620
RG-16	35143.6	63	700x380x300	880x440x620
RG-18	46403.2	72	920x380x300	1100x440x620

Waffle Baker & Cone Baker

Waffle Baker With Timer

Features

- Overall stainless steel body
- Cast iron plate coated, non-stick
- With temperature controller and five minutes timer setting

- This waffle baker is one of the latest style food cooker;
- It is popular with the advantages of clean ,sanitation, easy to operation and power saving.



Model	Voltage (V)	Power (kW)	Temperature (°C)	Net Weight (kg)	Dimensions (mm)
LR-WB-01	220	1.2	0~300	6	250x430x250
LR-WB-02	220	2.4	0~300	12	500x430x250
LR-WBL-01	220	1.2	0~300	6	250x430x250
LR-WBL-02	220	2.4	0~300	12	500x430x250

Waffle Baker With Timer

Features

- Overall stainless steel body
- Cast iron plate coated, non-stick
- With temperature controller and five minutes timer setting

Cone Baker

Features

- This waffle baker is one of the latest style food cooker;
- It is popular with the advantages of clean ,sanitation, easy to operation and power saving.



Model	Voltage (V)	Power (kW)	Temperature (°C)	Net Weight (kg)	Cooking Size(mm)	Dimensions (mm)
WB-03D	220	1.0	124~230	11	Dia. 180	255x440x320
WB-S	220	1.5	50~320	17	100x160	470x320x225
LR-CM-01	220	1.2	0~300	7	-	250x430x250
LR-CM-02	220	2.4	0~300	13	-	400x430x250

Crepe Maker

Electric Crepe Maker ⚡

Features

Designed with simplicity and efficiency in mind, this crepe maker's compact size is ideal for small prep areas or food trucks where space is limited. Built-to last, this crepe maker includes all of the essential features necessary to make sweet and savory signature crepes at your busy restaurant or hotel breakfast bar.

- Non-slip feet for added stability
- Thermostatic temperature control
- Heavy-duty stainless steel construction
- Warming and power indicator lights
- 16mm Non-stick cast iron plate
- 16" diameter plate provides ample room to evenly spread out batter and prevents crepes from sticking



Model	Voltage (V)	Power (kW)	Temperature (°C)	Net Weight (kg)	Cooking Surface Size(mm)	Dimensions (mm)
LR-DE-1	220	3	50~300	23	φ400x8	450x490x225
LR-DE-2	220	3+3	50~300	47	φ400x8	890x490x225
LR-DE-1	220	3	220~240	15	Φ400x8	450x490x235
LR-DE-2	220	3+3	220~240	30	Φ400x8	860x490x235

Gas Crepe Maker GAS

Features

Designed with simplicity and efficiency in mind, this crepe maker's compact size is ideal for small prep areas or food trucks where space is limited. Built-to last, this crepe maker includes all of the essential features necessary to make sweet and savory signature crepes at your busy restaurant or hotel breakfast bar.

- Non-slip feet for added stability
- Thermostatic temperature control
- Heavy-duty stainless steel construction
- Warming and power indicator lights
- 20mm Non-stick cast iron plate
- 16" diameter plate provides ample room to evenly spread out batter and prevents crepes from sticking.



Model	Gas Class	Power (MJ/h)	Net Weight (kg)	Cooking Surface Size(mm)	Dimensions (mm)
LR-VG-1A	LPG, Natural Gas,Coal Gas	36.5	25	φ400x8	450x540x300
LR-VG-2A	LPG, Natural Gas,Coal Gas	73	50	φ400x8	860x540x300

Hot Dog Steamer and Warmer



Hot Dog Steamer and Warmer ⚡

Features

This model's simple temperature control dial makes it easy for you to steam hot dogs while simultaneously warming any style of bun to perfection! It has a stainless steel construction with a compact design to offer you maximum efficiency and reliable performance while taking up a minimal amount of countertop space. It also keeps the condiments contained within the bun for a clean, delicious snack to enjoy on the go



- Unique European-style steamer and warmer
- Steams up to 30 hot dogs and warms up to 4 buns at a time
- Pyrex container and stainless steel basket for steaming 9" x 1 1/2" spikes
- Simple temperature control dial
- Stainless steel steam heater and construction

Model	Voltage (V)	Power (kW)	Temperature (°C)	Net Weight (kg)	Dimensions (mm)
HDD-1L	220	0.45	50~100	4	250x280x410
HDD-4L	220	0.65	50~100	6.2	480x280x410
HDD-6L	220	0.7	50~100	8	650x280x410

Corn Steamers

Features

- High capacity
- Steam food
- Detachable heating plate
- Temperature controllable: 30°C-110°C



Model	Voltage (V)	Power (kW)	Temperature (°C)	Net Weight (kg)	Dimensions (mm)
LR-CS48L	220	2.5	30-110	6	430x430x430

Hot Dog Machine



LR-HD Hot Dog Machine ⚡ **MOQ: 10PCS**

Features

- Stainless steel Rollers-durable & easy to clean.
- Heavy duty motor-drives the rollers.
- Excellent performance and easy control.
- Amade of stainless steel outer tube with embedded aluminum tube inside roller heating mode, fully automatic rotate 360, temperature transmission rapidly and heated evenly.
- Adopt imported thermostat automatic constant temperature control,the sausage could be heated evenly. And the temperature is adjustable to ensure the quality of the food and save the power.



Specifications

Model	Voltage (V)	Power (kW)	Temperature (°C)	Net Weight (kg)	Dimensions (mm)
LR-HD-5	220	0.5	0~200	6.5	440x250x175
LR-HD-7	220	0.7	0~200	8	440x325x175
LR-HD-9	220	0.9	0~200	12	550x400x175
LR-HD-11	220	1.1	0~200	14	550x475x175

WY Hot Dog Machine ⚡ **MOQ: 10PCS**

Features

- Stainless steel Rollers-durable & easy to clean.
- Heavy duty motor-drives the rollers.
- Excellent performance and easy control.
- Amade of stainless steel outer tube with embedded aluminum tube inside roller heating mode, fully automatic rotate 360, temperature transmission rapidly and heated evenly.
- Adopt imported thermostat automatic constant temperature control,the sausage could be heated evenly. And the temperature is adjustable to ensure the quality of the food and save the power.



Specifications

Model	Voltage (V)	Power (kW)	Temperature (°C)	Net Weight (kg)	Dimensions (mm)
WY-005	220	0.96	0~250	9	590x250x420
WY-007	220	1.33	0~250	11.5	590x330x420
WY-009	220	1.69	0~250	14	590x400x420
WY-011	220	2.06	0~250	16.5	590x480x420
WY-007D	220	1.33	0~250	11.5	590x330x420
WY-009D	220	1.69	0~250	14	590x400x420

Kebab Slicer

Kebab Slicer

Features

- Full stainless steel blade cover An adapter included
- Adjustment ring and screw for desired thickness
- Metal anti-slip body, ergonomic design, safe and easy handling Wear-resistant switch
- The front part is easily detachable for cleaning
- One smooth blade included in the unit and one serrated blade included in the package



2 Smooth blades

Specifications

Model	Voltage (V)	Power (kW)	Cutting Depth (mm)	Blade Dia (mm)	Capacity (kg/h)	Net Weight (kg)	Dimensions (mm)
EMS-100	220	0.08	0-8	100	60	1.4	230x180x265

Kebab Machine GAS

Features

- Easy to control, as it is quite easy to hang or remove the food.
- Easy to clear the pan to pick the oil.
- High efficiency and low energy wastage.
- Quickly bakes the food with 6~9 minutes.

Specifications

Model	Gas Class	Power (MJ/h)	Rotate Speed (r/min)	Net Weight (kg)	Dimensions (mm)
GB-800	LPG, Natural Gas,Coal Gas	32.7	5	23	540x650x950
GB-950	LPG, Natural Gas,Coal Gas	43.7	5	25	540x650x1050

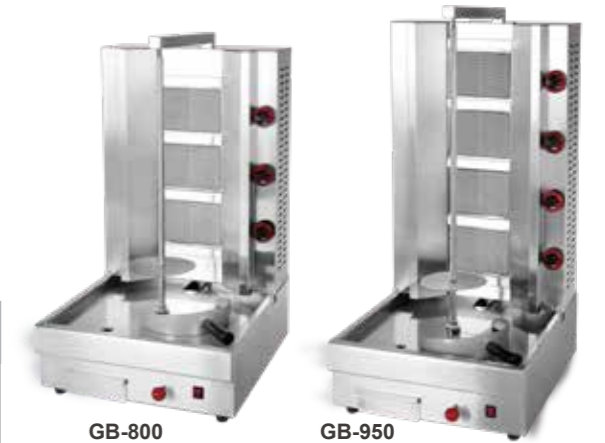

Kebab Machine

Features

- Easy to control, as it is quite easy to hang or remove the food.
- Easy to clear the pan to pick the oil.
- High efficiency and low energy wastage.
- Quickly bakes the food with 6~9 minutes.

Specifications

Model	Voltage (V)	Gas Class	Power	Rotate Speed (r/min)	Net Weight (kg)	Dimensions (mm)
GB-960	220	LPG, Natural Gas, Coal Gas	54.6MJ/h	5	27	540x650x1220
EB-850	220	-	8kW	2.5	26	540x650x950



Kebab Machine

Features

- Easy to control, as it is quite easy to hang or remove the food.
- Easy to clear the pan to pick the oil.
- High efficiency and low energy wastage.
- Quickly bakes the food with 6~9 minutes.

Specifications

Model	Voltage (V)	Power	Rotate Speed (r/min)	Temperature (°C)	Net Weight (kg)	Dimensions (mm)
PE-2	380	9.9kW	3.5	50~300	31	534x607x950
RG-2	220	53.8MJ/h	5	50~300	31	534x607x950



LINKRICH CATERING EQUIPMENT

Kebab Machine With Cabinet

Kebab Machine With Cabinet ⚡

Features

- The construction is stainless steel and come with the cabinet , more convenient.
- Group fire control can be adjusted according to the group you need to make the food evenly heaed.
- Infrared heating plate and heat-resistant metal mesh consitute a burner, flame burning evenly, high efficiency, energy saving.
- Easy to control, as it is quite easy to hang or remove the food.
- Easy to clear the pan to pick the oil.
- High efficiency and low energy wastage.
- Quickly bakes the food with 6~9 minutes.



EB-T800

EB-MT800

Specifications

Model	Voltage(V)	Power	Net Weight (kg)	Dimensions (mm)
EB-T800	220	8kW	60	650x600x1750
EB-MT800	220	16kW	110	1400x600x1750

Kebab Machine With Cabinet GAS

Features

- The construction is stainless steel and come with the cabinet , more convenient.
- Group fire control can be adjusted according to the group you need to make the food evenly heaed.
- Infrared heating plate and heat-resistant metal mesh consitute a burner, flame burning evenly, high efficiency, energy saving.
- Easy to control, as it is quite easy to hang or remove the food.
- Easy to clear the pan to pick the oil.
- High efficiency and low energy wastage.
- Quickly bakes the food with 6~9 minutes.



GB-G820

GB-MG820

Specifications

Model	Voltage(V)	Net Weight (kg)	Dimensions (mm)
GB-G820	220	65	650x600x1770
GB-MG820	220	115	1400x600x1770



Coffee Urn CE ⚡

Feature

- Quick&easy-just add cold water and fresh coffee grounds to hold up to quality coffee.
- Available in 10and 15 litre sizes suitable for all kinds of church,office,catered event or any other application where there is a need to quickly make a lot of coffee.
- Heating element at the bottom with dry protection.
- Long life concealed elements allowing easy cleaning inside the urn.
- Stylish brushed finish stainless steel exterior.
- Sight-glass with cup capacity graduations.
- Boil dry-protection.
- CP Series is stainless steel heating element, CP-A Series is aluminum heating element

A type



Specifications

Model	Voltage (V)	Power (kW)	Capacity (L)	Net Weight (kg)	Dimensions (mm)
CP-10	220	1.15	10	3.96	Φ 340x480
CP-10A	220	1.25	10	3.96	Φ 340x480
CP-15	220	1.15	15	4.6	Φ 340x590
CP-15A	220	1.25	15	4.6	Φ 340x590

Hot Water Urns

Hot Water Urn 
Feature

- Adjust temper-ature with inner heating element.
- Heating element at the bottom with dry protection.
- Available in 10,15,20,30,40 litre sizes.
- Long life concealed elements allowing easy cleaning inside the urn.
- Stylish brushed finish stainless steel exterior.
- Sight-glass with cup capacity graduations.
- WB-A series its Composite-bottom.
- Boil dry-protection .



Specifications

Model	Voltage (V)	Power (kW)	Capacity (L)	Net Weight (kg)	Dimensions (mm)
WB-10	220	2	10	2.8	φ290x405
WB-10A	220	2	10	2.7	φ290x405
WB-15	220	2.5	15	3.3	φ310x420
WB-15A	220	2.5	15	3.28	φ310x420
WB-20	220	2.5	20	3.62	φ310x523

Model	Voltage (V)	Power (kW)	Capacity (L)	Net Weight (kg)	Dimensions (mm)
WB-20A	220	2.5	20	3.58	φ310x523
WB-30	220	3	30	4.34	φ390x420
WB-30A	220	3	30	4.3	φ390x420
WB-40	220	3	40	4.84	φ390x523
WB-40A	220	3	40	4.76	φ390x523

Hot Water Urn 
Feature

- Come with the glass cover ,you can see the change in the bowl.
- Double liner, insulation better
- Available in 10,15,25,30,35,40, litre sizes.
- Boil dry-protection .



Specifications

Model	Voltage (V)	Power (kW)	Capacity (L)	Net Weight (kg)	Dimensions (mm)
WG-10	220	2	10	3.1	φ245x425
WG-15	220	2	15	3.9	φ245x495
WG-25	220	2	25	4.2	φ315x490
WG-30	220	2	30	4.7	φ315x540
WG-35	220	2	35	6.2	φ315x610
WG-40	220	2	40	6.6	φ315x660
WG-50	220	2	50	7.5	φ400x620
WG-60	220	2.5	60	7.7	φ400x660

Model	Voltage (V)	Power (kW)	Capacity (L)	Net Weight (kg)	Dimensions (mm)
WE-10	220	2	10	3.1	φ245x425
WE-15	220	.2	15	3.9	φ245x495
WE-25	220	2	25	4.2	φ315x490
WE-30	220	2	30	4.7	φ315x540
WE-35	220	2	35	6.2	φ315x610
WE-40	220	2	40	6.6	φ315x660

Commercial Contact Grill & Induction Cooker

Multi Ceramic Panini Sandwich Grill **Fast Warming up to 300°C in 5 min**

Features 

- Stainless steel base and stainless steel construction
- Heavy duty, glass cooking surface
- Removable stainless steel crumb/drip tray for easy cleaning
- Ideal for sizzling steaks, burgers, eggs and much more
- Exceptional quality and value
- Quick heating and fast recovery
- Non-slip rubber feet **MOQ: 10 PCS**



Specifications

Model	Voltage (V)	Net Weight (kg)	Power (kW)	Temperature (°C)	Cooking Surface Size (mm)	Dimensions (mm)
LR-FG-1	220	10.5	16	50~300	250x250	340x480x170
LR-FG-2	220	21	32	50~300	250x250x2	700x480x170

Electric Induction Cooker **MOQ: 10PCS**

- Multi-functional, can be used for frying, steaming, boiling, stewing, brasing,etc.
- Suitable for various working conditions, especially places that prohibit the use of open flames.
- Better quality when compared to the patchworks of small factories.
- Approved by international CE certification
- 6-stage firepower settings
- Easy and safe operation
- Automatic disconnect
- Faster cooking
- Energy saving



Model	Voltage (V)	Power (kW)	Temperature (°C)	Net Weight (kg)	Dimensions (mm)	MOQ (pcs)
LR-CH-3	220	3	150~250	7.6	350x468x135	10

Electric Ceramic Hob-Single & Hob-Double Head **MOQ: 10PCS**

- Multi-functional, can be used for frying, steaming, boiling, stewing, brasing,etc.
- Suitable for various working conditions, especially places that prohibit the use of open flames.
- Better quality when compared to the patchworks of small factories.
- Approved by international CE certification
- 6-stage firepower settings
- Easy and safe operation
- Automatic disconnect
- Faster cooking
- Energy saving



Model	Voltage (V)	Power (kW)	Temperature (°C)	Net Weight (kg)	Dimensions (mm)	MOQ (pcs)
LR-CH-2	220	1.8	150~250	4.8	350x420x110	5
LR-CH-4	220	3.6	150~250	8	666x420x110	5

Commercial Contact Grill



Linkrich Signature Contact Panini Sandwich Grill

Features ⚡ **Fast Warming up to 300°C in 15 min**

- Stainless steel base and stainless steel construction with stylish brushed finish
- With grooved cast iron plates
- Removable stainless steel crumb/drip tray for easy cleaning
- Ideal for sizzling steaks, burgers, eggs and much more
- Exceptional quality and value
- Quick heating and fast recovery
- Non-slip rubber feet
- EGO thermostat is optional



LR-811 LR-811R (Flat Bottom) LR-811E LR-811ER (Flat Bottom)

Specifications

Model	Voltage (V)	Net Weight (kg)	Power (kW)	Temperature (°C)	Cooking Surface Size (mm)	Dimensions (mm)
LR-811	220	14.5	1.8	50~300	214x214	370x305x185
LR-811R	220	14.5	1.8	50~300	214x214	370x305x185
LR-811E	220	20	2.2	50~300	340x220	460x370x190
LR-811ER	220	20	2.2	50~300	340x220	460x370x190

Linkrich Signature Contact Panini Sandwich Grill

Features ⚡ **Fast Warming up to 300°C in 15 min**

- Stainless steel base and stainless steel construction with stylish brushed finish
- With grooved cast iron plates
- Removable stainless steel crumb/drip tray for easy cleaning
- Ideal for sizzling steaks, burgers, eggs and much more
- Exceptional quality and value
- Quick heating and fast recovery
- Non-slip rubber feet
- EGO thermostat is optional



LR-813 LR-813R (Flat Bottom) LR-813B

Specifications

Model	Voltage (V)	Net Weight (kg)	Power (kW)	Cooking Surface Size (mm)	Dimensions (mm)
LR-813	220	28	2x1.8	485x230	565x370x190
LR-813R	220	28	2x1.8	485x230	565x370x190
LR-813B	220	28	2x1.8	485x230	565x370x190

Commercial Electric Deep Fryer

6 Liter Commercial Electric Deep Fryer ⚡

Features

- Ideal for chips and countless other deep-fry fast-foods
- Powerful countertop fryer with stainless steel lid
- Hygienic, safe and easy to clean
- Adjustable thermostatic control
- Solid intergral forming handle for fried basket
- Knitting two side basket, more solid and durable
- 21A inner waterproof switch, more durable
- Pan with handle for easy remove



LR-EF-061 CE LR-EF-062 CE

Specifications

Model	Voltage (V)	Power (kW)	Capacity (L)	Temperature (°C)	Net Weight (kg)	Dimensions (mm)
LR-EF-061	220	2	6	60~200	4.5	190x440x270
LR-EF-062	220	2x2	6x2	60~200	7	380x440x270

10 Liter Commercial Electric Deep Fryer ⚡

Features

- Ideal for chips and countless other deep-fry fast-foods
- Powerful countertop fryer with stainless steel lid
- Hygienic, safe and easy to clean
- Adjustable thermostatic control
- Solid intergral forming handle for fried basket
- Knitting two side basket, more solid and durable
- 21A inner waterproof switch, more durable
- The non-welded stainless steel oil bowl adopts one step molding technique and enhances
- Removable head
- Pan with handle for easy remove



LR-EF-101B LR-EF-102B

Specifications

Model	Voltage (V)	Power (kW)	Capacity (L)	Temperature (°C)	Net Weight (kg)	Dimensions (mm)
LR-EF-101B	220	3	10	60~250	7	280x465x310
LR-EF-102B	220	3x2	10x2	60~250	12	575x465x310



10/17 Liter Commercial Electric Deep Fryers (With Timer) ⚡

Features

- Powerful countertop fryer with stainless steel lid
- Hygienic, safe and easy to clean
- Ideal for chips and countless other deep-fry fast-foods
- Adjustable thermostatic control
- Basket included
- Removable head
- Pan with handle for easy remove



LR-EF-101
LR-EF-171 €€

LR-EF-102
LR-EF-172 €€

Specifications

Model	Voltage (V)	Power (kW)	Capacity (L)	Temperature (°C)	Net Weight (kg)	Dimensions (mm)
LR-EF-101	220	3	10	60~200	6	290x440x285
LR-EF-102	220	3x2	10x2	60~200	8	590x440x285
LR-EF-171 €€	220	5	17	60~200	9.5	293x500x330
LR-EF-172 €€	220	5x2	17x2	60~200	15.5	595x500x330

10/17 Liter Commercial Electric Fryers (With Drain Valve) ⚡

Features

- Powerful countertop fryer with stainless steel lid
- Hygienic, safe and easy to clean
- Ideal for chips and countless other deep-fry fast-foods
- Adjustable thermostatic control
- Basket included
- Removable head
- Pan with handle for easy remove



LR-EF-101V €€
LR-EF-171V

LR-EF-102V €€
LR-EF-172V

Specifications

Model	Voltage (V)	Power (kW)	Capacity (L)	Temperature (°C)	Net Weight (kg)	Dimensions (mm)
LR-EF-101V €€	220	4	10	60~200	7.5	280x460x325
LR-EF-102V €€	220	4x2	10x2	60~200	11	570x460x325
LR-EF-171V	220	5	17	60~200	9	320x540x380
LR-EF-172V	220	5x2	17x2	60~200	16.5	630x540x380



Electric table type frying furnace

Features ⚡

- Powerful standing fryer with stainless steel lid
- Hygienic, safe and easy to clean
- Ideal for chips and countless other deep-fry fast-foods
- Adjustable thermostatic control



CG-201V

CG-301V

Specifications

Model	Voltage (V)	Power (kW)	Capacity (L)	Net Weight (kg)	Dimensions (mm)
CG-201V	220~240	4.8	20	14	600X590X360
CG-301V	220~240	6	30	16	620x620x425

EF Commercial Electric Countertop Deep Fryers (With Drain Valve)

Features ⚡

- Powerful countertop fryer with stainless steel lid
- Hygienic, safe and easy to clean
- Ideal for chips and countless other deep-fry fast-foods
- Adjustable thermostatic control
- Basket included
- Removable head



EF-12L

EF-12L-2

Specifications

Model	Voltage (V)	Power (kW)	Capacity (L)	Temperature (°C)	Net Weight (kg)	Dimensions (mm)
EF-12L	220	3.25	12	60~200	10	285x470x410
EF-12L-2	220	6.5	12x2	60~200	17.5	580x470x410

EF Commercial Electric Countertop Deep Fryers

Features ⚡

- Powerful countertop fryer with stainless steel lid
- Hygienic, safe and easy to clean
- Ideal for chips and countless other deep-fry fast-foods
- Adjustable thermostatic control
- Basket included
- Removable head
- Pan with handle for easy remove



EF-4L EF-6L
EF-8L EF-11L

EF-4L-2 EF-6L-2
EF-8L-2 EF-11L-2

Specifications

Model	Voltage (V)	Power (kW)	Capacity (L)	Temperature (°C)	Net Weight (kg)	Dimensions (mm)
EF-4L	220	2	4	60~200	5	260x380x310
EF-4L-2	220	4	4x2	60~200	10	480x380x310
EF-6L	220	2.5	6	60~200	9.5	310x410x285
EF-6L-2	220	5	6x2	60~200	12	550x410x285
EF-8L	220	3.25	8	60~200	6	310x410x340
EF-8L-2	220	6.5	8x2	60~200	14	550x410x340
EF-11L	220	3.5	11	60~200	7	320x440x340
EF-11L-2	220	7	11x2	60~200	15	670x440x340

Countertop Gas Deep Fryers GAS

Features

- Powerful countertop fryer with stainless steel lid
- Hygienic, safe and easy to clean
- Ideal for chips and countless other deep-fry fast-foods
- Adjustable thermostatic control
- Basket included



LR-GF5.5-1 (1 Tank)

LR-GF5.5-2 (2 Tanks)
LR-GF11-1 (1 Tank)

Specifications

Model	Gas Class	Power (MJ/h)	Capacity (L)	Net Weight (kg)	Dimensions (mm)
LR-GF5.5-1	LPG,Natural Gas,Coal Gas	19.9	5.5	12	290x520x445
LR-GF5.5-2	LPG,Natural Gas,Coal Gas	39.8	5.5x2	22	580x520x445
LR-GF11-1	LPG,Natural Gas,Coal Gas	39.8	11	22	580x520x445



Countertop Gas Deep Fryers GAS

Features

- Powerful countertop fryer with stainless steel lid
- Hygienic, safe and easy to clean
- Ideal for chips and countless other deep-fry fast-foods
- Adjustable thermostatic control
- Basket included



LR-GF-81

LR-GF-82

Specifications

Model	Gas Class	Power (MJ/h)	Capacity (L)	Net Weight (kg)	Dimensions (mm)
LR-GF-81	LPG,Natural Gas,Coal Gas	11.3	8	14	310x660x550
LR-GF-82	LPG,Natural Gas,Coal Gas	22.7	8x2	27	616x660x550

Countertop Gas Deep Fryers

Features GAS

- Powerful countertop fryer with stainless steel lid
- Hygienic, safe and easy to clean
- Ideal for chips and countless other deep-fry fast-foods
- Basket included



LR-GF8.5-1

LR-GF8.5-2

Specifications

Model	Gas Class	Power (MJ/h)	Capacity (L)	Net Weight (kg)	Dimensions (mm)
LR-GF8.5-1	LPG,Natural Gas,Coal Gas	19	5.5	9.5	300x510x470
LR-GF8.5-2	LPG,Natural Gas,Coal Gas	32	5.5x2	14.5	580x510x470

Commercial Standing Electric Countertop Deep Fryers

Features ⚡

- Powerful standing fryer with stainless steel lid
- Hygienic, safe and easy to clean
- Ideal for chips and countless other deep-fry fast-foods
- Adjustable thermostatic control
- Basket included



Specifications

Model	Voltage (V)	Power (kW)	Capacity (L)	Temperature (°C)	Net Weight (kg)	Dimensions (mm)
LR-EF48-1	3~380	9	48	60~200	32.5	420x850x935
LR-EF48-2	3~380	9x2	48x2	60~200	56	870x850x935

Commercial Electric Standing Deep Fryer

Features CE ⚡

- Powerful standing fryer with stainless steel lid
- Hygienic, safe and easy to clean
- Ideal for chips and countless other deep-fry fast-foods
- Adjustable thermostatic control
- Basket included



Specifications

Model	Voltage (V)	Power (kW)	Capacity (L)	Temperature (°C)	Net Weight (kg)	Dimensions (mm)
LR-14L-2	380	9x2	14x2	60~200	60	400x800x1100
LR-28L	380	18	28	60~200	60	400x800x1100
LR-28L-2	380	18x2	28x2	60~200	100	800x800x1100

Lift Digital Electric Fryer ⚡

Features

- Using stainless steel high-efficiency heating wire, heating up quickly
- Compensate for the temperature drop during frying in time to ensure the quality of frying
- The computer board has 10 sections of product frying function and reminder function to realize the operation of standardized management



Specifications

Model	Voltage (V)	Power (kW)	Capacity (L)	Temperature (°C)	Dimensions (mm)
DF-30K	380	18	28	50-200	400x800x1125
DF-38K	380	18+18	28+28	50-200	800x800x1125

Commercial Gas Standing Deep Fryer GAS

Features

- Powerful standing fryer with stainless steel lid
- Hygienic, safe and easy to clean
- Ideal for chips and countless other deep-fry fast-foods
- Adjustable thermostatic control
- Gas 1-Tank Fryer (1-Basket)



Specifications

Model	Gas class	Tube Dia (mm)	Power (MJ/h)	Capacity (L)	Net Weight (kg)	Dimensions (mm)
ZH-RC-1	LPG,Natural Gas,Coal Gas	19	55.8	21	60	400x900x850

Commercial Standing Gas Deep Fryers

Features GAS

- Powerful standing fryer with stainless steel lid
- Hygienic, safe and easy to clean
- Ideal for chips and countless other deep-fry fast-foods
- Adjustable thermostatic control
- Basket included
- With drain valve for easy drain oil
- 1.0mm stainless steel tank



Specifications

Model	Gas Pressure (Pa)	Power (MJ/h)	Capacity (L)	Temperature (°C)	Net Weight (kg)	Dimensions (mm)
LR-GF-171	2800	20.8	17x1	60~200	22	340x615x630
LR-GF-172	2800	41.6	17x2	60~200	38	680x615x630

Commercial Standing Gas Deep Fryers GAS

Features

- Powerful standing fryer with stainless steel lid
- Hygienic, safe and easy to clean
- Ideal for chips and countless other deep-fry fast-foods
- Adjustable thermostatic control
- Basket included
- 1.0mm stainless steel tank



Specifications

Model	Gas Pressure (Pa)	Power (MJ/h)	Capacity (L)	Temperature (°C)	Net Weight (kg)	Dimensions (mm)
LR-GF46-1	2800	240.4	46x1	60~200	48	450x700x980
LR-GF46-2	2800	240.4x2	46x2	60~200	83	870x700x980



Commercial Gas Standing Deep Fryer



Features

- 30.000 BTU/ burner
- Millivolt(snao action)thermostat,200 F-400 F
- Stainless steel front and door , Sides and back are galvanized steel
- Large cold zone to trap food particles
- 1-1/4" dia.full port drain valve for fast and complete oil draining
- 2" diameter adjustable Stainless Steel legs standard,casters optional
- 1.5mm thickness Tank is fully peened for smoother welds & easy cleaning
- Drain pipe holder attached to inside door
- Twin nickel plated baskets
- 1 year parts &labor warranty

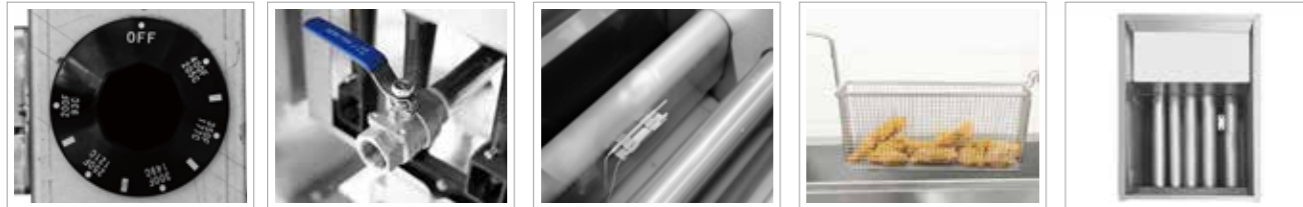
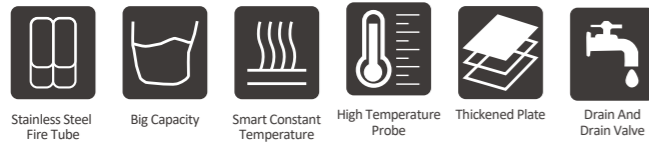

Temperature control thermostats for peace of mind
 30mm diameter drain pipe with lockable ball valve
 1.5mm stainless steel Tank, One burner connect one oil pipe , Heating more faster-1. 3 oil pipe, 4 oil pipe and 5 oil pipe optional.
 Thickened and reinforced stainless steel frying basket
 1.5mm stainless steel tank

Specifications

Model	Gas Source and Pressure	Maximum Power (kW)	Capacity (L)	Net Weight (kg)	Dimensions (mm)
LR-3G	LPG(2800pa), Gas(2000pa), Artificial gas(1000pa)	27	30-38	71	395x780x1125
LR-4G	LPG(2800pa), Gas(2000pa), Artificial gas(1000pa)	36	35-45	71	395x780x1112
LR-5G	LPG(2800pa), Gas(2000pa), Artificial gas(1000pa)	43.5	35-45	84	530x780x1125

Table Top Pressure Fryer ⚡

Features

- Frying under high pressure,makes the meat crispy out-side and seal the juice inside.
- Samll size to save the space, large capacity, easy to operate,high efficiency.
- Standard electro-mechanical control with easy to use temperature and timer controls.
- Automatic pressure release valve to ensure the safety.
- Proven round cooking well design: Engineered for more uniform heat distribution, durability and efficiency, no cold spots or corners



Specifications

Model	Voltage (V)	Power (kW)	Capacity (L)	Temperature (°C)	Net Weight (kg)	Dimensions (mm)
PF-16	220	3	16	-	21	440x570x520

Commercial Standing Pressure Fryer Manual Control

Features

- High-efficiency heat exchange system: High-efficiency heat exchange system produces among the lowest average exhaust gas temperatures in the industry , so it get fast recovery and energy savings.
- Fast and productive: Cooks up to 6 pieces of fresh chicken per load in under 10 minutes"
- High quality stainless steel body and lid, makes the machine stable with elegant appearance. Stainless steel rectangular fry pot promotes more even cooking.
- Standard electro-mechanical control with easy to use temperature and timer controls.Automatic pressure release valve to ensure the safety.
- Lower cooking oil consumption,very low oil absorption into food.Better tasting food-seals in natural juice.
- 4 heavy duty casters,2 locking, easy to move and position.



Specifications

Model	Type	Voltage (V)	Power (kW)	Capacity (L)	Gas consumption (kg/h)	Net Weight (kg)	Dimensions (mm)
PF-25E	Electric	380	12	25	-	95	470x940x1100
PF-25G	Gas	220	0.1	25	0.48	125	490x1080x1100
PF-25EA	Electric	380	13.5	25	-	135	470x920x1180
PF-25GA	Gas	220	0.65	25	-	160	500x1080x1180
PF-25ED	Electric	380	13.5	25	-	135	470x920x1180
PF-25GD	Gas	220	0.65	25	-	160	500x1080x1180



Commercial Donut Machine

- Size and shapes donuts.
- With timer exposed, easy to adjust the time.
- Health and environmental protection, machinery noise
- With oil drain valve for easy oil changes and cleaning
- It is easy to operate with high efficiency, stable performance
- The height of outlet can be adjusted according the level of the oil because the machine use the screw to adjust.
- Electric cake donut machine, having 3 moulds, you can produce different



T-101

T-100



For 40mm inside diameter, 80mm outside diameter of donut. 700 pcs/hour



For 36mm inside diameter, 70mm outside diameter of donut. 800 pcs/hour



For 20mm inside diameter, 38mm outside diameter of donut. 1200 pcs/hour



Specifications

Model	Power (kW)	Voltage (V)	Capacity (L)	Temperature (°C)	Outside Diameter of Donut (mm)	Inside Diameter of Donut (mm)	Net Weight (kg)	Dimensions (mm)
T-101	3	220	12	50~300°C	80	25/35/45	25	1030x400x650
T-100	6	220	25	50~300°C	80	25/35/45	48	1200x500x720

4/5 automatic donuts machine

Features

- Continuous food delivery
- #201 stainless steel
- Simple operation interface
- Adjustable temperature escape temperature difference
- The silicone MATS
- Increase friction and stabilize the fuselage
- Adjustable piston



Specifications

Model	Voltage (V)	Power (kW)	Material	Net Weight (kg)	Dimensions (mm)
NP- 4	220	2.8	Stainless steel(#201)	26	620x525x440
NP- 5	220	2.8	Stainless steel(#201)	26	620x525x440

6 automatic donuts machine

Features

- Continuous food delivery
- #201 stainless steel
- Simple operation interface
- Adjustable temperature escape temperature difference
- The silicone MATS
- Increase friction and stabilize the fuselage
- Adjustable piston



Specifications

Model	Voltage (V)	Power (kW)	Material	Net Weight (kg)	Dimensions (mm)
NP- 6	220/110	2.8/11.97	Stainless steel(#201)	26	620x525x440

Countertop Electric Grill and Griddle ⚡

Features

- Stainless steel base and stainless steel construction with stylish brushed finish
- 12mm thickness of the hot plate
- Polished mild steel cooking surface
- Removable stainless steel crumb/drip tray for easy cleaning
- Ideal for sizzling steaks, burgers, eggs and much more
- Exceptional quality and value
- Quick heating and fast recovery
- Non-slip rubber feet



LR-EG-538T CE

LR-EG-300
LR-EG-420
LR-EG-450

Specifications

Model	Voltage (V)	Power (kW)	Cooking Surface (mm)	Thickness of Hot Plate (mm)	Temperature (°C)	Net Weight (kg)	Dimensions (mm)
LR-EG-538T	220	3	497x336	8	50~300	19.5	500x480x220
LR-EG-300	220	1.5	294x292	12	50~300	14	300x360x250
LR-EG-420	220	1.8	336x350	12	50~300	18.5	400x420x250
LR-EG-450	220	2	356x390	12	50~300	22	360x460x250

Countertop Electric Grill and Griddle ⚡

Features

- Stainless steel base and stainless steel construction with stylish brushed finish
- 12mm thickness of the hot plate
- Polished mild steel cooking surface
- Removable stainless steel crumb/drip tray for easy cleaning
- Ideal for sizzling steaks, burgers, eggs and much more
- Exceptional quality and value
- Quick heating and fast recovery
- Non-slip rubber feet



LR-EG-548 CE

LR-EG-618
LR-EG-738

LR-EG-530

LR-EG-600
LR-EG-750

Specifications

Model	Voltage (V)	Power (kW)	Cooking Surface (mm)	Thickness of Hot Plate (mm)	Temperature (°C)	Net Weight (kg)	Dimensions (mm)
LR-EG-548	220	3	522x366	8	50~300	25	555x473x250
LR-EG-618	220	6	610x511	8	50~300	40	620x613x325
LR-EG-738	220	4.4	732x415	8	50~300	37	735x524x293
LR-EG-530	220	3	527x422	8	50~300	34	530x600x475
LR-EG-600	220	4.4	597x422	8	50~300	39	600x600x475
LR-EG-750	220	6	747x422	8	50~300	46	750x600x475

Electric Grill and Griddle ⚡

Features

- Polished mild steel plate, 10mm in thickness
- Splash guard to prevent food spillage
- Stainless steel structure
- Temperature range 50-300 C
- Large stainless steel oil collector with handle
- Bakelite knob, cool to touch
- Large opening of front grease through
- Stainless steel heating element
- Anti slippery rubber foot
- Heating and power indicator



LR-818

LR-820

Specifications

Model	Voltage (V)	Power (kW)	Cooking Surface (mm)	Plate type	Net Weight (kg)	Dimensions (mm)
LR-818	220~240	3	548x350	Flat	23	550x450x230
LR-820	220~240	4.4	728x400	Flat	34	730x500x230
LR-822	220~240	4.4	728x400	½ Flat + ½ grooved	34	730x500x230

Electric Grill and Griddle ⚡

Features

- Stainless steel base and stainless steel construction with stylish brushed finish
- Heavy duty, polished mild steel cooking surface
- Removable stainless steel crumb/drip tray for easy cleaning
- Ideal for sizzling steaks, burgers, eggs and much more
- Exceptional quality and value
- Quick heating and fast recovery
- Non-slip rubber feet



Specifications

Model	Voltage (V)	Power (kW)	Cooking Surface (mm)	Thickness of Hot Plate (mm)	Temperature (°C)	Net Weight (kg)	Dimensions (mm)
LR-EH-750	220	6	747x522	8	50~300	58	750x700x1000

Gas Grill and Griddle GAS

Features

- Stainless steel base and stainless steel construction with stylish brushed finish
- Heavy duty, polished mild steel cooking surface
- Removable stainless steel crumb/drip tray for easy cleaning
- Ideal for sizzling steaks, burgers, eggs and much more
- Exceptional quality and value
- Quick heating and fast recovery
- Non-slip rubber feet



LR-GT-750

LR-GT-36L
LR-GT-48L

Specifications

Model	Gas Class	Gas Pressure (Pa)	Power (MJ)	Cooking Surface Size (mm)	Thickness of Hot Plate (mm)	Net Weight (kg)	Dimensions (mm)
LR-GT-750	LPG, Coal Gas, Natural Gas	2800	59.4	747x522	8	78	750x700x1000
LR-GT-36L	LPG	2800	63.25	909x482	20	105	915x685x950
LR-GT-48L	LPG	2800	83.03	1200x482	20	131	1200x685x950

Gas Grill and Griddle

Features

- Independently-controlled, heat evenly
- Continuous pilot for instant ignition
- Features reversible, cast iron top grates
- Heavy-duty, adjustable feet provide stability
- Made of durable, easy-to-clean stainless steel
- Includes a waste tray for easy cleanup
- Available in 16", 24", 36", 48" and 60" size



Specifications

Model	Description	Gas Pressure (Pa)	Heat Power (MJ/h)	Net Weight (kg)	Dimensions (mm)
LR-EG-16S	16" size	2800	31.6	41	404x640x390
LR-EG-24S	24" size	2800	63.3	52	604x640x390
LR-EG-36S	36" size	2800	95.0	80	904x640x390
LR-EG-48S	48" size	2800	126.6	135	1204x640x390
LR-EG-60S	60" size	2800	158.2	140	1504x640x390

Countertop Electric Grill and Griddle

Features

- Stainless steel base and stainless steel construction with stylish brushed finish
- 12mm thickness of the hot plate
- Polished mild steel cooking surface
- Removable stainless steel crumb/drip tray for easy cleaning
- Ideal for sizzling steaks, burgers, eggs and much more
- Exceptional quality and value
- Quick heating and fast recovery
- Non-slip rubber feet



LR-RG-530L
LR-RG-530L-2 (Flat Left)

LR-RG-600L
LR-RG-600L-2 (Flat Left)
LR-RG-750L
LR-RG-750L-2 (Flat Left)

Specifications

Model	Gas Class	Gas Pressure (Pa)	Power (MJ)	Cooking Surface Size (mm)	Thickness of Hot Plate (mm)	Net Weight (kg)	Dimensions (mm)
LR-RG-530L	LPG	2800	26.2	527x422	8	30	530x600x475
LR-RG-530L-2	LPG	2800	26.2	527x422	8	29	530x600x475
LR-RG-600L	LPG	2800	43.45	597x422	8	34	600x600x475
LR-RG-600L-2	LPG	2800	43.45	597x422	8	33	600x600x475
LR-RG-750L	LPG	2800	59.4	747x422	8	40	750x600x475
LR-RG-750L-2	LPG	2800	59.4	747x422	8	39	750x600x475

LR-GA Gas Grill and Griddle

Features

- Stainless steel base and stainless steel construction with stylish brushed finish
- Heavy duty, polished mild steel cooking surface
- Removable stainless steel crumb/drip tray for easy cleaning
- Ideal for sizzling steaks, burgers, eggs and much more
- Exceptional quality and value
- Quick heating and fast recovery
- Non-slip rubber feet



LR-GA0-718

LR-GA0-721

LR-GA0-720
LR-GA0-722

Specifications

Model	Gas Class	Gas Pressure (Pa)	Power (kW)	Thickness of Hot Plate(mm)	Cooking Surface Size (mm)	Net Weight (kg)	Dimensions (mm)
LR-GA-718	LPG、 Natural Gas、 Coal Gas	2800	8	8	550x350	29	610x560x400
LR-GA-721	LPG、 Natural Gas、 Coal Gas	2800	8	8	550x350	29	610x560x400
LR-GA-720	LPG、 Natural Gas、 Coal Gas	2800	12	8	730x400	43	790x590x400
LR-GA-722	LPG、 Natural Gas、 Coal Gas	2800	12	8	730x400	43	790x590x400

Automatic Japanese Style Gyoza Machine

Features

- The gyoza machine is made by stainless steel 304 and service life will be longer than other raw material .
- It is full automatic dumpling frying machine.
- Automatic water injection, heating. The time of frying adjustable.
- Whole process only need 5 minutes so it is no problem for weekend and holiday.
- Our gyoza machine is widely used in bakery equipment, the restaurant , snack food factory , meat processing factory ,paste process factory ,dinning room,etc.



DS-1303

DS-1302

Specifications

Model	Voltage (V)	Power (kW)	Cooking Pan (mm)	Temperature (°c)	Plate size (mm)	Net Weight (kg)	Dimensions (mm)
DS-1303	220	3	20mm Thick Nanbu Cast Iron Cooking	50-250	210x320x40	32	300x600x450
DS-1302	220	3+3	20mm Thick Nanbu Cast Iron Cooking	50-250	210x320x40x2	64	600x600x450

LINKRICH COOKING EQUIPMENT

Radiant Charbroiler

Gas Radiant Charbroiler Features

- Independently-controlled, heat evenly
- Continuous pilot for instant ignition
- Features reversible, cast iron top grates
- Heavy-duty, adjustable feet provide stability
- Made of durable, easy-to-clean stainless steel
- Includes a waste tray for easy cleanup



LR-RG-12A



LR-RG-24A



LR-RG-36A

Specifications

Model	Gas Class	Gas Pressure (Pa)	Heat Power (MJ/h)	Cooking Surface Size (mm)	Net Weight (kg)	Dimensions (mm)
LR-RG-12A	LPG, Natural Gas, Coal Gas	2800	14.7	286x520	56	365x770x(370+110)
LR-RG-24A	LPG, Natural Gas, Coal Gas	2800	29.3	550x520	94	610x770x(370+110)
LR-RG-36A	LPG, Natural Gas, Coal Gas	2800	44	800x520	134	860x770x(370+110)
LR-RG-48A	LPG, Natural Gas, Coal Gas	2800	58.6	1050x520	174	1220x770x(370+110)

Gas Radiant Charbroiler Features

- Independently-controlled, heat evenly
- Continuous pilot for instant ignition
- Features reversible, cast iron top grates
- Heavy-duty, adjustable feet provide stability
- Made of durable, easy-to-clean stainless steel
- Includes a waste tray for easy cleanup
- Available in 16", 24", 36", 48" and 60" size



LR-RG-16S



LR-RG-24S



LR-RG-36S

Specifications

Model	Description	Gas Pressure (Pa)	Heat Power (MJ/h)	Net Weight (kg)	Dimensions (mm)
LR-RG-16S	16" size	2800	31.6	49	404x640x390
LR-RG-24S	24" size	2800	63.3	54	604x640x390
LR-RG-36S	36" size	2800	95.0	74	904x640x390
LR-RG-48S	48" size	2800	126.6	98	1204x640x390
LR-RG-60S	60" size	2800	158.2	122	1504x640x390

LINKRICH COOKING EQUIPMENT

Countertop Cooking Range

LINKRICH

Double Tank Deep Fryer & Gas Fryer Features

- Stainless steel base and stainless steel construction with stylish brushed finish
- Quick heating and fast recovery
- The temperature range from 50°C~190°C
- Two 8L capacity oil tanks it's separate, it's more convenient.
- Come with the drain tap, after working, take out the oil faster.
- The gas range and electric range it's optional.



TEF-8+8



TEF-8+8R

Specifications

Model	Voltage (V)	Heat Power (MJ/H)	Power (kW)	Tank Size (mm)	Tank Capacity (L)	Net Weight (kg)	Dimensions (mm)
TEF-8+8	220	-	2.8+2.8	-	8+8	29	600x600x430
TEF-8+8R	-	40.3	-	300x240x150	8+8	29	600x650x470

Electric Bain Marie & Gas Bain Marie Features

- Stainless steel base and stainless steel construction with stylish brushed finish
- Quick heating and fast recovery
- The temperature range from 50°C~100°C
- Come with the drain tap, after working, take out the water faster.
- The gas range and electric range it's optional.



TY-4



TY-4R

Specifications

Model	Voltage (V)	Heat Power (MJ/H)	Power (kW)	Specification	Net Weight (kg)	Dimensions (mm)
TY-4	220	-	1.5	2x1/3x6" and 2x1/2x6"	24	700x600x350
TY-4R	-	21.8	-	2x1/3x6" and 2x1/2x6"	29	700x650x470

Paste Cooker Features

- Stainless steel base and stainless steel construction with stylish brushed finish
- Quick heating and fast recovery
- The temperature range its 50-100°C
- Come with the water drain tap, after working, can take out the water faster.
- The gas range and electric range it's optional.



TM-6



TM-6R

Specifications

Model	Voltage (V)	Heat Power (MJ/H)	Power (kW)	Capacity (L)	Net Weight (kg)	Dimensions (mm)
TM-6	220	-	6	6 Noodle Basket	25	600x600x350
TM-6R	-	21.8	-	6 Noodle Basket	25	600x650x470

Electric Stove ⚡

Features

- Stainless steel base and stainless steel construction with stylish brushed finish
- Quick heating and fast recovery
- The heating plate power its 2kw each one.



Specifications

Model	Voltage (V)	Power (kW)	Net Weight (kg)	Dimensions (mm)
TB-4	220	8	20	600x600x350

Gas Stove GAS

Features

- Stainless steel base and stainless steel construction with stylish brushed finish
- Quick heating and fast recovery
- Each burner power its 12.6MJ/h, its bigger and high efficiency.



Specifications

Model	Heat Power (MJ/H)	Net Weight (kg)	Dimensions (mm)
TB-4.R	51.1	44	570x650x470

Electric Griddle ⚡

Features

- Stainless steel base and stainless steel construction with stylish brushed finish
- Quick heating and fast recovery
- The griddle plate thickness its 16mm , and the size is 536x330mm
- The gas range and electric range it's optional.



Specifications

Model	Voltage (V)	Power (kW)	Griddle Plate Dimensions (mm)	Net Weight (kg)	Dimensions (mm)
TGH-21	220	5	536x330x16	43	600x600x350

Gas Griddle GAS

Features

- Stainless steel base and stainless steel construction with stylish brushed finish
- Quick heating and fast recovery
- The griddle plate thickness its 16mm , and the size is 536x330mm
- The gas range and electric range it's optional.



Specifications

Model	Heat Power (MJ/H)	Griddle Plate Dimensions (mm)	Net Weight (kg)	Dimensions (mm)
TGH-21.R	29.1	536x330x16	46	600x650x470

Electric Lava Rock Grill ⚡

Features

- Stainless steel base and stainless steel construction with stylish brushed finish
- Quick heating and fast recovery
- The lava rack size gas type is 560x440mm the electric size is 480mmx360mm
- The gas range and electric range it's optional.



Specifications

Model	Voltage (V)	Power (kW)	Roasting Surface (mm)	Net Weight (kg)	Dimensions (mm)
THS-150	220	4.8	570x350	43	650x600x350

Gas Lava Rock Grill GAS

Features

- Stainless steel base and stainless steel construction with stylish brushed finish
- Quick heating and fast recovery
- The lava rack size gas type is 560x440mm the electric size is 480mmx360mm
- The gas range and electric range it's optional.



Specifications

Model	Heat Power (MJ/H)	Roasting Surface (mm)	Net Weight (kg)	Dimensions (mm)
THS-150.R	58.23	570x350	46	600x650x470



LINKRICH signature cooking line offer a variety of styles Western Combination Cooking Line to suit your needs, including cooktops, electric fryers, bain marie etc

These products are great for hotels, restaurants, cafes, bistros, and bakeries in their back-of-house area. Constructed from highly durable materials, Western Combination Cooking Line is designed for frequent, daily use, so they're sure to handle the demands of your establishment.

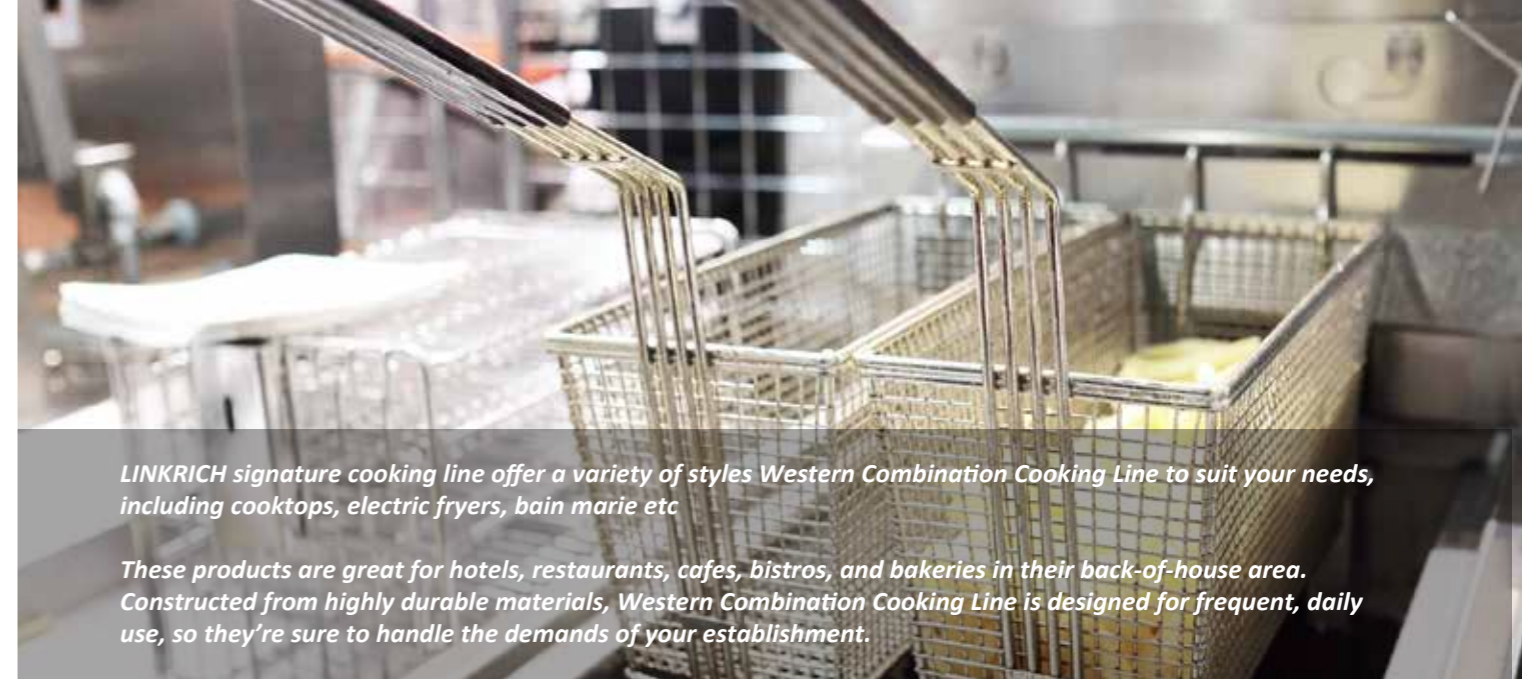

LINKRICH signature cooking line offer a variety of styles Western Combination Cooking Line to suit your needs, including cooktops, electric fryers, bain marie etc

These products are great for hotels, restaurants, cafes, bistros, and bakeries in their back-of-house area. Constructed from highly durable materials, Western Combination Cooking Line is designed for frequent, daily use, so they're sure to handle the demands of your establishment.



Gas Griddle With Cabinet 1/3 Grooved 

Model:	ZH-RG-L	JZH-RG-L
Power (MJ/H)	13.67	39.31
Net Weight (kg)	70	65
Dimensions (mm)	800x900x970	700x750x910



Gas Lava Rock Grill 

Model:	ZH-RH-L	JZH-RH-L
Power (MJ/H)	61.87	61.87
Net Weight (kg)	80	70
Dimensions (mm)	800x900x970	700x750x910



Gas Fryer 2 Tank with Cabinet 

Model:	ZH-RCx2-L	JZH-RCx2-L
Power (kW)	112.84	112.84
Temp Range (°C)	50~190	50~190
Net Weight (kg)	100	90
Dimensions (mm)	800x900x970	700x750x910mm



Gas Pasta Cooker with Cabinet 

Model:	ZH-RM-16-L	ZH-RM-12-L
Power (MJ/H)	80.07	69.15
Net Weight (kg)	70	60
Dimensions (mm)	800x900x970	700x750x910

Electric Griddle With Cabinet 1/3 Grooved 

Model:	ZH-TG-L	JZH-TG-L
Voltage (V)	380	380
Power (kW)	15	8
Temp Range (°C)	50~300	50~300
Net Weight (kg)	80	70kg
Dimensions (mm)	800x900x970	700x750x910

Electric Lava Rock Grill 

Model:	ZH-TH-L	JZH-TH-L
Voltage (V)	380	380
Power (kW)	12	9
Temp Range (°C)	50~300	50~300
Net Weight (kg)	80	65
Dimensions (mm)	800x900x970	700x750x910

Electric Fryer 2 Tank with Cabinet 

Model:	ZH-TCx2-L	JZH-TCx2-L
Voltage (V)	380	380
Power (kW)	24	24
Temp Range (°C)	50~190	50~190
Net Weight (kg)	80	70
Dimensions (mm)	800x900x970	700x750x910

Electric Pasta Cooker with Cabinet 

Model:	ZH-TM-16-L	ZH-TM-12-L
Voltage (V)	380	380
Power (kW)	16	16
Net Weight (kg)	60	50
Dimensions (mm)	800x900x970	700x750x910



LINKRICH signature cooking line offer a variety of styles Western Combination Cooking Line to suit your needs, including cooktops, electric fryers, bain marie etc

These products are great for hotels, restaurants, cafes, bistros, and bakeries in their back-of-house area. Constructed from highly durable materials, Western Combination Cooking Line is designed for frequent, daily use, so they're sure to handle the demands of your establishment.



LINKRICH signature cooking line offer a variety of styles Western Combination Cooking Line to suit your needs, including cooktops, electric fryers, bain marie etc

These products are great for hotels, restaurants, cafes, bistros, and bakeries in their back-of-house area. Constructed from highly durable materials, Western Combination Cooking Line is designed for frequent, daily use, so they're sure to handle the demands of your establishment.



Gas Bain Marie with Cabinet 

Model:	ZH-RB-L	JZH-RB-L
Power (MJ/H)	40.03	34.94
Net Weight (kg)	85	75
Dimensions (mm)	800x900x970	700x750x910



Gas Tilting Braising Pan 

Model:	ZH-RS-L	JZH-RS-L
Power (MJ/H)	94.63	94.63
Capacity (L)	80	80
Net Weight (kg)	140	100
Dimensions (mm)	800x900x970	800x900x970



Gas Range With 4-burner With Gas Oven 

Model:	ZH-RQ-4-L	JZH-RQ-4-L
Power (MJ/H)	134.68	134.68
Net Weight (kg)	90kg	80kg
Dimensions (mm)	800x900x970mm	700x750x910mm



Electric Range With 4-Hot Plate & Electric Oven 

Model:	ZH-TT-4-L	JZH-TT-4D-L
Power (kW)	16+4.8	16+4.8
Net Weight (kg)	80	80
Dimensions (mm)	800x900x970	800x900x970

Electric Bain Marie with Cabinet 

Model:	ZH-TB-L	JZH-TB-L
Voltage (V)	380	380V
Power (kW)	6	5
Net Weight (kg)	65	55
Dimensions (mm)	800x900x970	700x750x910

Electric Tilting Braising Pan 

Model:	ZH-TS-L	JZH-TS-L
Voltage (V)	380	380
Power (kW)	12	9
Capacity (L)	80L	60
Net Weight (kg)	135	120
Dimensions (mm)	800x900x970	700x750x910

Gas Range With 4-burner With Electric Oven 

Model:	ZH-TQ-4-L	JZH-TQ-4-L
Voltage (V)	380	380
Power (kW)	36	36
Net Weight (kg)	90	70
Dimensions (mm)	800x900x970	700x750x910



COMBINATION COOKING LINE



COMBINATION COOKING LINE Combination Cooking Line

LINKRICH

LINKRICH Signature 700 Cook Centre



With a high power output, this product can heat up quickly, ensuring a high energy efficiency.

Adopts a die casting iron top, with heat conducting grooves which conducts heat quickly and keeps food warm.

Also comes equipped with adjustable feet.

Lava Rock Grill With Cabinet



Griddle With Cabinet



2-Tank Fryer With Cabinet



	JZH-RH	JZH-RG	JZH-RCx2
Heat Power(MJ/h):	52	42.6	111.9
Net Weight(kg):	113	95	85
Dimensions(mm):	700x700x(850+70)	700x700x(850+70)	700x700x(850+70)

	ZH-RH	ZH-RG	ZH-RCx2
Heat Power(MJ/h):	61.4	42.6	111.9
Net Weight(kg):	150	125	124
Dimensions(mm):	800x900x(850+60)	800x900x(850+60)	800x900x(850+60)

With a high power output, this product can heat up quickly, ensuring a high energy efficiency.

High pressure heating makes it safe and reliable.

The cooking pot has strainer inside it, which makes it easy to operate.

Water can be easily poured in and drained out.

Also comes equipped with adjustable feet.

Pasta Cooker With Cabinet



Bain Marie With Cabinet



	ZH-RM-16	ZH-RM-S6	ZH-RB
Heat Power(MJ/h):	85	84.9	57.8
Net Weight(kg):	100	102	90
Dimensions(mm):	800x900x(850+60)	800x900x(850+60)	800x900x(850+60)

	JZH-RM-12	JZH-RM-S4	JZH-RB
Heat Power(MJ/h):	85	84.9	57.8
Net Weight(kg):	77	102	77
Dimensions(mm):	700x700x(850+70)	700x700x(850+60)	700x700x(850+60)



LINKRICH Signature Cook Centre

With a high power output, this product can heat up quickly, ensuring a high energy efficiency.

High pressure heating makes it safe and reliable.

The cooking pot has strainer inside it, which makes it easy to operate.

Water can be easily poured in and drained out.

Also comes equipped with adjustable feet.

With a high power output, this product can heat up quickly, ensuring a high energy efficiency.

Adopts a die casting iron top, with heat conducting grooves which conducts heat quickly and keeps food warm.

Also comes equipped with adjustable feet.

Lava Rock Grill With Cabinet



ZH-TH

Power(kW):
Voltage(V):
Net Weight(kg):
Dimensions(mm):

12
380
128
800x900x(850+60)

Griddle With Cabinet



ZH-TG

Power(kW):
Voltage(V):
Net Weight(kg):
Dimensions(mm):

9
380
95
700x700x(850+60)

2-Tank Fryer With Cabinet



ZH-TCx2

Power(kW):
Voltage(V):
Net Weight(kg):
Dimensions(mm):

24
380
94
800x900x(850+60)

Pasta Cooker With Cabinet



ZH-TM-16

Power(kW):
Voltage(V):
Net Weight(kg):
Dimensions(mm):

18
380
86
800x900x(850+60)

Bain Marie With Cabinet



ZH-TB

Power(kW):
Voltage(V):
Net Weight(kg):
Dimensions(mm):

6
380
86
800x900x(850+60)

JZH-TM-12

JZH-TM-S4

JZH-TB

12
380
75
700x700x(850+60)

18
380
86
800x900x(850+60)

6
380
86
800x900x(850+60)

LINKRICH Signature GAS Cook Centre



The combination of the design, the beautiful shape and whole stainless steel constructions results in a luxurious product.

Provides a simplification of the operation procedure.

Concerning the stove, the burner can be easy taken out for cleaning.

High efficiency and low energy consumption.

The combination of the design, the beautiful shape and whole stainless steel constructions results in a luxurious product.

Provides a simplification of the operation procedure.

Concerning the stove, the burner can be easy taken out for cleaning.

High efficiency and low energy consumption.

Gas Range 4-Burner With Gas Oven



Heat Power(MJ/h):
Net Weight(kg):
Dimensions(mm):

ZH-RQ-4
67.8
156
800x900x(850+70)

Gas Range 6-Burner With Gas Oven



Heat Power(MJ/h):
Net Weight(kg):
Dimensions(mm):

JZH-RQ-4
67.8
117
700x700x(850+70)

Gas Range 4-Burner With Cabinet



Gas Range 4-Burner With Electric Oven



Heat Power(MJ/h):
Power(Kw):
Voltage(V):
Net Weight(kg):
Dimensions(mm):

ZH-TQ-4
51.3
4.8
380
136
800x900x(850+70)

Gas Range 6-Burner With Electric Oven



Heat Power(MJ/h):
Power(Kw):
Voltage(V):
Net Weight(kg):
Dimensions(mm):

JZH-TQ-4
51.3
4.8
380
111
700x700x(850+70)

Gas Range With 4-Burner & Griddle With Electric Oven



Heat Power(MJ/h):
Power(Kw):
Voltage(V):
Net Weight(kg):
Dimensions(mm):

ZH-TQ-6
76.9
4.8
380
179
1200x900x(850+70)

Heat Power(MJ/h):
Power(Kw):
Voltage(V):
Net Weight(kg):
Dimensions(mm):

JZH-TQ-6
76.9
4.8
380
144
1050x700x(850+70)

Heat Power(MJ/h):
Power(Kw):
Voltage(V):
Net Weight(kg):
Dimensions(mm):

ZH-TJ-4
67.4
4.8
380
171
1200x900x(850+70)

Heat Power(MJ/h):
Power(Kw):
Voltage(V):
Net Weight(kg):
Dimensions(mm):

JZH-TJ-4
67.4
4.8
380
154
1050x700x(850+70)

LINKRICH Signature GAS Cook Centre



With a high power output, this product can heat up quickly, ensuring a high energy efficiency.

High pressure heating makes this machine very safe and reliable.

The cooking pot also has a strainer inside of it, which makes it very easy to operate.

Water can be easily poured in and drained out.

Also comes equipped with adjustable feet.



JZH-RO

Heat Power(kW):	16
Capacity(L):	60
Net Weight(kg):	112
Maximum Pressure of Inter Layer(MPa):	>50
Dimensions(mm):	700x750x(850+60)

ZH-RO100

Heat Power(MJ/h):	26
Capacity(L):	100
Net Weight(kg):	140
Maximum Pressure of Inter Layer(MPa):	>50
Dimensions(mm):	800x900x(850+120)

ZH-RO150

Heat Power(MJ/h):	26
Capacity(L):	150
Net Weight(kg):	140
Maximum Pressure of Inter Layer(MPa):	>50
Dimensions(mm):	800x900x(850+120)



JZH-RS

Heat Power(kW):	24
Capacity(L):	60
Net Weight(kg):	100
Maximum Pressure of Inter Layer(MPa):	--
Dimensions(mm):	700x750x(850+60)

ZH-RS

Heat Power(MJ/h):	26
Capacity(L):	80
Net Weight(kg):	140
Maximum Pressure of Inter Layer(MPa):	--
Dimensions(mm):	800x900x(850+120)

ZH-RO150

Heat Power(MJ/h):	26
Capacity(L):	150
Net Weight(kg):	140
Maximum Pressure of Inter Layer(MPa):	>50
Dimensions(mm):	800x900x(850+120)

LINKRICH Signature Cook Centre



With a high power output, this product can heat up quickly, ensuring a high energy efficiency.

High pressure heating makes this machine very safe and reliable.

The cooking pot also has a strainer inside of it, which makes it very easy to operate.

Water can be easily poured in and drained out.

Also comes equipped with adjustable feet.

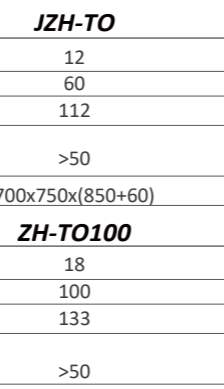

JZH-TO

Power(kW)	12
Capacity(L):	60
Net Weight(kg):	112
Maximum Pressure of Inter Layer(MPa):	>50
Dimensions(mm):	700x750x(850+60)

ZH-TO100

Power(kW)	18
Capacity(L):	100
Net Weight(kg):	133
Maximum Pressure of Inter Layer(MPa):	>50
Dimensions(mm):	800x900x(850+120)

ZH-TO150

Power(kW)	18
Capacity(L):	150
Net Weight(kg):	133
Maximum Pressure of Inter Layer(MPa):	>50
Dimensions(mm):	800x900x(850+120)

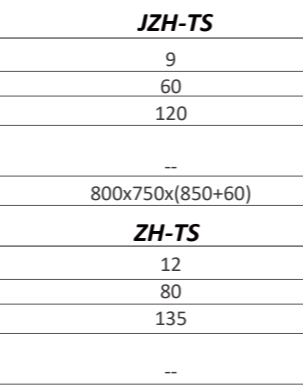

JZH-TS

Power(kW)	9
Capacity(L):	60
Net Weight(kg):	120
Maximum Pressure of Inter Layer(MPa):	--
Dimensions(mm):	800x750x(850+60)

ZH-TS

Power(kW)	12
Capacity(L):	80
Net Weight(kg):	135
Maximum Pressure of Inter Layer(MPa):	--
Dimensions(mm):	800x900x(850+120)

LINKRICH Signature Cook Centre



The housing is made from 304 stainless steel, whilst the worktop is made with a 1.5mm thickness to ensure strength.

Core accessories(including hot plates and thermostats) made in Germany are adopted to ensure stable and reliable performance.

Comes equipped with safety thermostats to ensure safety.

The 20cm stainless steel feet can be adjusted;adjustable range:plus or minus 25cm.

Electric 4-plate Cooker With Cabinet



Power(kW):	9.2
Voltage(V):	380
Net Weight(kg):	63
Dimensions(mm):	800x900x(850+60)

Electric 4-plate Cooker With Oven



Power(kW):	14
Voltage(V):	380
Net Weight(kg):	104
Dimensions(mm):	800x900x(850+60)

Electric 4 Hot-plate Cooker&Oven



Power(kW):	20.8
Voltage(V):	380
Net Weight(kg):	129
Dimensions(mm):	800x900x(850+60)

Electric 4 Ceramic Hob With Cabinet



Power(kW):	8
Voltage(V):	380
Net Weight(kg):	66
Dimensions(mm):	700x700x(850+60)

Electric 4 Ceramic Hob With Oven



Power(kW):	12.8
Voltage(V):	380
Net Weight(kg):	94
Dimensions(mm):	700x700x(850+60)

Electric 6 Hot-plate Cooker&Oven



The housing is made from 304 stainless steel, whilst the worktop is made with a 1.5mm thickness to ensure strength.

Core accessories(including hot plates and thermostats) made in Germany are adopted to ensure stable and reliable performance.

Comes equipped with safety thermostats to ensure safety.

The 20cm stainless steel feet can be adjusted;adjustable range:plus or minus 25cm.

Countertop Gas Burner 

Features

- Octagon cast iron burner, each 25000 BTU/hr
- 12" x12"(30x30cm) castiron grate
- Standby pilot for easy start
- Stainless steel adjustable heavy duty legs
- Zinc alloy knob with chrome coating
- Crumb tray at the bottom
- Easy conversion from natural gas to Propane or vice versa
- Stainless steel in the front, and galvanized sides and back
- Available in 2, 4 and 6 burners



EHP-2S



EHP-4S



EHP-6S

Specifications

Model	Heat Power (MJ/h)	Description	Net Weight (kg)	Dimensions (mm)
EHP-2S	52.7	Two burner	32	300x690x340
EHP-4S	105.5	Three burners	57	600x690x340
EHP-6S	158.2	Four burners	83	900x690x340

Countertop Gas Burner 

Features

- Octagon cast iron burner, each 109946 BTU/hr
- Stainless steel adjustable heavy duty legs
- Zinc alloy knob with chrome coating
- Crumb tray at the bottom
- Easy conversion from natural gas to Propane or vice versa
- Stainless steel in the front, and galvanized sides and back
- Available in 1, 2, 4 and 6 burners



RB-1W



RB-2W



RB-4W

Specifications

Model	Heat Power (MJ/h)	Description	Net Weight (kg)	Dimensions (mm)
RB-1W	116	One burner	55	457x625x520
RB-2W	55.9	Two burners 12"x24"(300x600)	34	305x734x376
RB-4W	111.8	Four burners 12"x24"(300x600)	59	610x734x376
RB-6W	167.7	Six burners 12"x24"(300x600)	92	915x734x376

Stand Gas Burner 

Features

- Pressed top, burners worked cast-iron, crown in Iron ,with very high output.
- 12" x12"(30x30cm) castiron grate
- Lighting by back-burner, thermocouple protection.
- Made stainless steel, adjustable feet in stainless steel.
- With stainless steel shelves, convenient and practical



BV-33



BV-34



BV-35

Specifications

Model	Heat Power (MJ/h)	Net Weight (kg)	Dimensions (mm)
BV-33	79.2	45	700x700x(850+100)
BV-34	118.8	65	1100x700x(850+100)
BV-35	162	85	1400x700x(850+100)

Chinese Wok Cooker 

Features

- The stove panel above is 0.8mm of thickness, decorative edge 1.0mm, front plate, side plate and back plate are 0.6mm.
- Boil a pot of water costs 8 minutes and a red pan for 8 seconds.
- It can be designed to turn off the burner automatically when the pot is taken away, as a protective measure.
- Self-developed burner and fan, the national standard is 83 DB(decibel) , and our products can achieve 75 DB



Specifications

Model	Heat Power (MJ/h)	Description	Net Weight (kg)	Dimensions (mm)
XH-10	187.2	Two burner	196	900x800x1150
XH-18	374.4	Two burner	196	1400x800x1150
XH-20	374.4	Two burner	380	2000x950x1150

Gas burners with griddle & oven

Features

- Fully MIG welded frame for stability
- Stainless steel front, back-riser
- 6" stainless steel adjustable heavy duty legs
- Two/Four open top burners, each 30,000 BTU/hr
- Coved pilot burner cover to prevent clogging from spillage
- Heavy duty cast grates, 12"x12" (30x30cm) in size, easy to be removed
- 31,000 BTU/hr. U-shape burner for each bottom oven
- With 20000 BTU/hr burner (1/2 pc) for griddle
- Full size sheet pans fit side-to-side or front-to-back.
- Oven thermostat adjusts from 250°F to 550°F
- Two oven racks and four rack positions
- 12"/24" griddle plate, 3/4" thickness, optional with castors



RGR36-G12

RGR36-G24

Specifications

Model	Description	Total input (btu/hr)	Net Weight	Dimensions (mm)
RGR36-G12	4 burners with griddle & oven	171,000	108kg	914 x 826 x 1532 mm
RGR36-G24	2 burners with griddle & oven	131,000	183 kg	914 x 829 x 1530 mm

Gas burners with griddle & oven

Features

- Fully MIG welded frame for stability
- Stainless steel front, back-riser
- 6" stainless steel adjustable heavy duty legs
- Six open top burners, each 30,000 BTU/hr
- Coved pilot burner cover to prevent clogging from spillage
- Heavy duty cast grates, 12"x12" (30x30cm) in size, easy to be removed
- 31,000 BTU/hr. U-shape burner for each bottom oven
- With 20000 BTU/hr burner (2 pc) for griddle
- Full size sheet pans fit side-to-side or front-to-back.
- Oven thermostat adjusts from 250°F to 550°F
- Two oven racks and four rack positions
- 24" griddle plate, 3/4" thickness, optional with castors



RGR60-G24

RGR60-GS24

Specifications

Model	Description	Total input (btu/hr)	Net Weight	Dimensions (mm)
RGR60-G24	6 burners with griddle & oven	282,000	310kg	1524 x 829 x 1530 mm
RGR60-GS24	6 burners with griddle & oven	278,000	330kg	1523 x 774 x 1532 mm

Gas burners with oven

Features

- Fully MIG welded frame for stability
- Stainless steel front, back-riser, galvanized sides
- 6" stainless steel adjustable heavy duty legs
- Four/Six open top burners, each 30,000 BTU/hr
- Coved pilot burner cover to prevent clogging from spillage
- Heavy duty cast grates, 12"x12" (30x30cm) in size, easy to be removed
- 31,000 BTU/hr. U-shape burner for bottom oven
- Full size sheet pans fit side-to-side or front-to-back.
- Oven thermostat adjusts from 250°F to 550°F
- Two oven racks and four rack positions
- Optional with castors



RGR24

RGR36

Specifications

Model	Description	Total input (btu/hr)	Net Weight	Dimensions (mm)
RGR24	4 burners with oven	151,000	132kg	609 x 830 x 1520 mm
RGR36	6 burners with oven	211,000	167 kg	915 x 829 x 1520 mm

Gas burners with oven

Features

- Fully MIG welded frame for stability
- Stainless steel front, back-riser, galvanized sides
- 6" stainless steel adjustable heavy duty legs
- Ten open top burners, each 30,000 BTU/hr
- Coved pilot burner cover to prevent clogging from spillage
- Heavy duty cast grates, 12"x12" (30x30cm) in size, easy to be removed
- 31,000 BTU/hr. U-shape burner for bottom oven
- Full size sheet pans fit side-to-side or front-to-back.
- Oven thermostat adjusts from 250°F to 550°F
- Two oven racks and four rack positions
- Optional with castors



Specifications

Model	Description	Total input (btu/hr)	Net Weight	Dimensions (mm)
RGR60	10 burners with oven	362,000	280kg	1524 x 829 x 1520 mm

XF Electric Food Holding Cabinet ⚡

Features

- With the whole body made of stainless steel, the machine is simple and elegant, with smooth and flat surface, nice-looking color and dirt-proof design, ensuring easy cleaning.
- The one stretch forming interior and water pan are made through superb techniques.
- The natural convection heating mode ensures quick heating and constant and even temperature for keeping food warm..
- The steam forms during heating will help retain moisture of food and its taste during the process.
- The temperature can be accurately adjusted for different food. The newly added automatic safety function can protect both the food and equipment.



Model	Voltage (V)	Power (kW)	Capacity	Chamber Size (mm)	Net Weight (kg)	Dimensions (mm)
XF-10S	220	2.7	10 layers	540x680x1380	130	790x975x1795

XF Electric Food Holding Cabinet ⚡

Features

- With the whole body made of stainless steel, the machine is simple and elegant, with smooth and flat surface, nice-looking color and dirt-proof design, ensuring easy cleaning.
- The one stretch forming interior and water pan are made through superb techniques.
- The natural convection heating mode ensures quick heating and constant and even temperature for keeping food warm..
- The steam forms during heating will help retain moisture of food and its taste during the process.
- The temperature can be accurately adjusted for different food. The newly added automatic safety function can protect both the food and equipment.



Model	Voltage (V)	Power (kW)	Capacity	Chamber Size (mm)	Net Weight (kg)	Dimensions (mm)
XF-11B	220	3	11 layers	540x680x1380	182	790x975x1795

XF Electric Food Holding Cabinet CE ⚡

Features

- With the whole body made of stainless steel, the machine is simple and elegant, with smooth and flat surface, nice-looking color and dirt-proof design, ensuring easy cleaning.
- The one stretch forming interior and water pan are made through superb techniques.
- The natural convection heating mode ensures quick heating and constant and even temperature for keeping food warm..
- The steam forms during heating will help retain moisture of food and its taste during the process.
- The temperature can be accurately adjusted for different food.
- The newly added automatic safety function can protect both the food and equipment.



Model	Voltage (V)	Power (kW)	Capacity	Chamber Size (mm)	Net Weight (kg)	Dimensions (mm)
XF-5	220	3	5 layers	540x680x940	136	790x975x1350

XF Electric Food Holding Cabinet CE ⚡

Features

- With the whole body made of stainless steel, the machine is simple and elegant, with smooth and flat surface, nice-looking color and dirt-proof design, ensuring easy cleaning.
- The one stretch forming interior and water pan are made through superb techniques.
- The natural convection heating mode ensures quick heating and constant and even temperature for keeping food warm..
- The steam forms during heating will help retain moisture of food and its taste during the process.
- The temperature can be accurately adjusted for different food.
- The newly added automatic safety function can protect both the food and equipment.



Model	Voltage (V)	Power (kW)	Capacity	Chamber Size (mm)	Net Weight (kg)	Dimensions (mm)
XF-22	220	3	22 layers	1350x680x1380	320	1540x940x1795

COMMERCIAL ELECTRIC RICE STEAMER



Widely used in factories, schools, institutions, military units, hotels, restaurants, etc., suitable for steamed rice, bread, buns, meat products, and can be used as multi-use tableware disinfection.
High quality stainless steel heat pipe, more efficiency and energy saving.
Airbag embedded multi-temperature silicone door seal.
Heat-resistant polyester double-layer structure rigid foam insulation layer, sealing strong, good insulation effect.
Automatic pulse electronic ignition, easy to operate
Automatic Watering, The timer device, Water shortage protection device, the machine more safety.



LR-ERC-16
LR-ERC-24

LR-ERC-6 / LR-ERC-8
LR-ERC-10 / LR-ERC-12

Model	Power (kW)	Voltage (V)	Door Quantity	Tray Quantity	Net Weight (kg)	Chamber Size (mm)	Dimensions (mm)
LR-ERC-6	8/9	220/380	1	6	55	600x435x690	720x650x960
LR-ERC-8	8/9	220/380	1	8	60	600x435x850	720x650x1120
LR-ERC-10	12	380	1	10	65	600x435x1010	720x650x1280
LR-ERC-12	12	380	1	12	70	600x435x1170	720x650x1440
LR-ERC-16	20	380	2	16	81.3	(600x435x850)x2	1470x650x1120
LR-ERC-24	24	380	2	24	131.5	(600x435x1170)x2	1470x650x1440

COMMERCIAL GAS RICE STEAMER



Widely used in factories, schools, institutions, military units, hotels, restaurants, etc., suitable for steamed rice, bread, buns, meat products, and can be used as multi-use tableware disinfection.
High quality stainless steel heat pipe, more efficiency and energy saving.
Airbag embedded multi-temperature silicone door seal.
Heat-resistant polyester double-layer structure rigid foam insulation layer, sealing strong, good insulation effect.
Accidental gas tuto turn off protection device, Fire-tube heat exchangers, Automatic watering, Over-temperature protection device, more safety.
LR-GRC Series its With fan pulse ignition, LR-GRC-A its cellular electronic ignition



LR-GRC-16/A
LR-GRC-24/A

LR-GRC-6/A / LR-GRC-8/A
LR-GRC-10/A / LR-GRC-12/A

Model	Gas	Heat Load (MJ/h)	Door Quantity	Tray Quantity	Net Weight (kg)	Chamber Size (mm)	Dimensions (mm)
LR-GRC-6	LPG 2800Pa	43.8	1	6	46.5	600x435x850	720x670x1160
LR-GRC-8	LPG 2800Pa	43.8	1	8	51.4	600x435x1010	720x670x1320
LR-GRC-10	LPG 2800Pa	43.8	1	10	55.8	600x435x1170	720x670x1480
LR-GRC-12	LPG 2800Pa	43.8	1	12	60.8	600x435x1330	720x670x1640
LR-GRC-16	LPG 2800Pa	43.8x2	2	16	98.5	(600x435x850)x2	1470x670x1320
LR-GRC-24	LPG 2800Pa	43.8x2	2	24	116.5	(600x435x1170)x2	1470x670x1640
LR-GRC-6A	LPG 2800Pa	43.8	1	6	72.5	600x435x950	720x670x1160
LR-GRC-8A	LPG 2800Pa	43.8	1	8	77.5	600x435x1110	720x670x1320
LR-GRC-10A	LPG 2800Pa	43.8	1	10	82.5	600x435x1270	720x670x1480
LR-GRC-12A	LPG 2800Pa	43.8	1	12	87.5	600x435x1330	720x670x1640
LR-GRC-16A	LPG 2800Pa	43.8x2	2	16	114.2	(600x435x850)x2	1470x670x1320
LR-GRC-24A	LPG 2800Pa	43.8x2	2	24	166.5	(600x435x1170)x2	1470x670x1640

LUXURY RICE STEAMER

Widely used in factories, schools, institutions, military units, hotels, restaurants, etc., suitable for steamed rice, bread, buns, meat products, and can be used as multi-use tableware disinfection.
High quality stainless steel heat pipe, more efficiency and energy saving.
Airbag embedded multi-temperature silicone door seal.
Heat-resistant polyester double-layer structure rigid foam insulation layer, sealing strong, good insulation effect.
Automatic pulse electronic ignition, easy to operate
Accidental gas tuto turn off protection device, Fire-tube heat exchangers, Automatic watering, Over-temperature protection device, more safety.



LR-ERC-90
LR-ERC-120

LR-GRC-90
LR-GRC-120

Model	Voltage	Power	Capacity (L)	Net Weight (kg)	Dimensions (mm)
LR-ERC-90	380V	24kW	30	260	900x1000x1890
LR-ERC-120	380V	36kW	30	300	1200x1000x1890
LR-GRC-90	LPG Natural Gas 2800pa	72MJ/H	30	275	900x1000x1890
LR-GRC-120	LPG Natural Gas 2800pa	72MJ/H	30	320	1200x1000x1890

Popcorn Machine ⚡ CE
Features

- High-output, side-hinged, hard-coat anodized aluminum kettle provides optimum performance and easy cleaning.
- Built-in warming deck heats popcorn from underneath the bottom tray.
- Old maid drawer collects the unpopped kernels or "old maids".
- Stainless steel bottom tray.
- 50-watt R20 presentation lamp lights the cabinet interior and highlights the popped corn for added impulse sales.



Model	Voltage (V)	Power (kW)	Output (oz.per/hour)	Net Weight (kg)	Boiler Temperature(°C)	Bottom Temperature(°C)	Dimensions (mm)
EB-10	220	1.45	-	17	0~245	0~65	500x350x670
801	220	1.43	96	23	0~245	0~65	500x360x660
802	220	1.43	96	20	0~245	0~65	580x420x740
817	220	1.3	96	22	0~245	0~65	560x420x760

Popcorn Machine ⚡ CE
Features

- High-output, side-hinged, hard-coat anodized aluminum kettle provides optimum performance and easy cleaning.
- Sturdy cabinet construction, designed to withstand heavy use without damage.
- Built-in warming deck heats popcorn from underneath the bottom tray.
- Old maid drawer collects the unpopped kernels or "old maids".
- Stainless steel bottom tray, drop door and old maid drawer are removable for quick cleaning.
- Tempered glass side and back panels are designed for safety as well as easy cleaning.
- 50-watt R20 presentation lamp lights the cabinet interior and highlights the popped corn for added impulse sales.
- Coordinating Popcorn Machine Cart sold below for greater mobility.



Model LR-PM-6E (Red/Black)

Voltage: 220V
Power: 1.175kW
Output: 1 tray/3 min
Net Weight: 23kg
Dimensions: 450x375x585mm

Popcorn Machine cart
Model:LR-POP6C-S
650x435x925mm

Model LR-PM-6A (Red/Black)

Voltage: 220V
Power: 1.35kW
Output: 1 tray/2 min
Net Weight: 23kg
Dimensions: 560x417x770mm

Popcorn Machine cart
Model:LR-POP6C
940x500x825mm

Cotton Candy Machine



Cotton Candy Machine ⚡ CE

Features

- Output: 30s/pc, Max 7pcs/min, Sugar Usage: 23g / pc
- Pink spray and lovely appearance , Can produce multi-colored cotton candy
- Comes with ON-OFF switch, HEAT switch; Voltage Meter, Fuse and Booster.
- Copper rotating head, fuse for safety use, Electric Leakage Protection Switch, volt controller and display meter
- Operating disc and fuselage can be separated with 4 safe lock, can be easy cleaning and maintenance of the machine
- Four holes at the bottom of the cotton machine for connecting into the foot pad or cart. (Cart is not included)

Model	Voltage (V)	Power (kW)	Output (pcs/hour)	Net Weight (kg)	Dimensions (mm)
LR-CM-03	220	1.3	300	9.5	530x530x410



Cotton Candy Machine ⚡ CE

Features

- Output: 30s/pc, Max 7pcs/min, Sugar Usage: 23g / pc
- Pink spray and lovely appearance , Can produce multi-colored cotton candy
- Comes with ON-OFF switch, HEAT switch; Voltage Meter, Fuse and Booster.
- Copper rotating head, fuse for safety use, Electric Leakage Protection Switch, volt controller and display meter
- Operating disc and fuselage can be separated with 4 safe lock, can be easy cleaning and maintenance of the machine
- Four holes at the bottom of the cotton machine for connecting into the foot pad or cart. (Cart is not included)

Model	Voltage (V)	Power (kW)	Output (pcs/hour)	Net Weight (kg)	Dimensions (mm)
LR-CM-02S	220	1.05	300	14	520x520x510



Cotton Candy Machine ⚡ CE

Features

- Output: 30s/pc, Max 7pcs/min, Sugar Usage: 23g / pc
- Pink spray and lovely appearance , Can produce multi-colored cotton candy
- Comes with ON-OFF switch, HEAT switch; Voltage Meter, Fuse and Booster.
- Copper rotating head, fuse for safety use, Electric Leakage Protection Switch, volt controller and display meter
- Operating disc and fuselage can be separated with 4 safe lock, can be easy cleaning and maintenance of the machine
- Four holes at the bottom of the cotton machine for connecting into the foot pad or cart. (Cart is not included)

Model	Voltage (V)	Power (kW)	Output (pcs/hour)	Net Weight (kg)	Dimensions (mm)
LR-CM-02WS	220	1.3	300	17	800x560x960



Hot Food Display Warmer& LRH Pizza Warmer

Hot Food Display Warmer ⚡

Feature

- Removable crumb tray
 - Temperature indicating gauge for monitoring internal temperature
 - Convenient sliding doors provide quick, easy access
 - With Interior light
 - Four side thick tempered glass, delicious food could be seen all around
 - Adopt fantastic quality thermostat to hold food items at optimum temperature
 - Water-well humidity control to keep moisture, texturer and freshness of food
 - Insulated top and bottom tiers for high efficiency heating operation
 - Edge protected glass doors on metal runners
- It is ideal for keeping food like pasties, pies, chicken and other meats at the perfect warm temperature ready for serving



DH-13



DH-14

Specifications

Model	Power (kW)	Voltage (V)	Temperature (°C)	Net Weight (kg)	Dimensions (mm)
DH-13	0.9	220	40~80	27	550x450x770
DH-14	0.88	220	40~80	27	550x450x770

LRH Pizza Warmer ⚡

Feature

- Removable crumb tray
 - Temperature indicating gauge for monitoring internal temperature
 - Convenient sliding doors provide quick, easy access
 - With Interior light
 - Four side thick tempered glass, delicious food could be seen all around
 - Adopt fantastic quality thermostat to hold food items at optimum temperature
 - Water-well humidity control to keep moisture, texturer and freshness of food
 - Insulated top and bottom tiers for high efficiency heating operation
 - Edge protected glass doors on metal runners
- It is ideal for keeping food like pasties, pies, chicken and other meats at the perfect warm temperature ready for serving



LRH-108L



LRH-97L-2

Specifications

Model	Power (kW)	Voltage (V)	Temperature (°C)	Net Weight (kg)	Dimensions (mm)
LRH-108L	1.2	220	30~90	33	470x470x870
LRH-97L-2	0.8	220	30~90	22	460x448x785

Food Warmer & Food Display Steamer

Food Warmer ⚡

Feature

- It features 4 levels, which allows you to stock numerous food and reduce the need of re-stocking.
- Removable shelves to simplify cleaning.
- Holds perfectly due to a combination of conduction heat and impingement heat transfer
- The motor, light, curtain are from famous international supplier.



LR-WSB-1750



LR-WS-1200

Model	Power (kW)	Voltage (V)	Temperature (°C)	Net Weight (kg)	Dimensions (mm)
LR-WSB-1450 2 Brakes	3.2	220	60~80	115	620x975x1920
LR-WSB-1750 3 Brakes	3.6	220	60~80	280	1020x975x1920
LR-WS-1200	1.839	220	25~80	180	1200x800x1900

Food Display Steamer ⚡

Features

- Adjustable shelf height and shelf angle
- Resettable hi-limit thermostat turns off power to the heater and upper lighting
- Smooth stainless steel body, curved glass, luxury style
- Easy-to-fill water pan, unique water tube allows for easy monitoring of water level and can be used to quickly refill or drain the unit
- Equipped with water proof light bulb, makes the food even more attractive
- Sliding shelves for easy access to product



Model	Voltage (V)	Power (kW)	Temperature (°C)	Net Weight (kg)	Dimensions (mm)
MME-500S	220	0.9	30~110	22	380x400x745
MME-600S	220	0.9	30~110	23	457x518x825

Commercial Food Display Warmer

Features

- It is good ideal for canteens, bakeries, cafes, fast food restaurants and many other catering establishments
- Precise temperature conditioning, cover a range from 30~85°C, keep the food tastes fresh
- The top cabinet can be used for advertising light boxes, using the new electric light illumination, more prominent food color attract customers.
- Easy loading, cleaning and serving



Model	Voltage (V)	Power (kW)	Temperature (°C)	Net Weight (kg)	Dimensions (mm)
FW-4	220	0.85	40~80	16	350x425x550

Countertop Heated Display Warmer

Countertop Heated Display Warmer

With Sliding Door ⚡

Features

- Great for convenience stores, snack bars, and more
- Maximum temperature of 85 degrees
- 3 stainless steel racks
- Front and rear sliding doors
- Thermostatic temperature controls



Model	Voltage (V)	Power (kW)	Temperature (°C)	Net Weight (kg)	Dimensions (mm)
LR-WS-66	220	1.84	30~80	37	660x437x655
LR-WS-90	220	1.84	30~80	50	900x480x610
LR-WS-120	220	2.2	30~80	72	1200x480x810

Countertop Heated Display Warmer ⚡

Features

- Designed with the option of utilizing the heat and humidity control, can keep variety of food products warmer for an extended period of time.
- Glass and Stainless Steel Construction



Model	Voltage (V)	Power (kW)	Temperature (°C)	Net Weight (kg)	Dimensions (mm)
LR-WS-861	220	1.2	30~85	21.2	380x490x560
LR-WS-862	220	1.2	30~85	33	650x490x580
LR-WS-863	220	1.5	30~85	41	900x490x580

Hot Food Display Warmer

Commercial Curved Glass Hot Food Display Warmer

Features

- It is good ideal for canteens, bakeries, cafes, fast food restaurants and many other catering establishments
- Easy thermostatically controlled.
- 4 sides clear glass with front curved glass and internal light for excellent presentation.
- Water tray included to add humidity to cabinet.
- With 2 service trays and 2 shelves.



Model	Voltage (V)	Power (kW)	Temperature (°C)	Net Weight (kg)	Dimensions (mm)
FW-3	220	1.2	30~85	25	660x500x620
FW-3S	220	1.2	30~85	35	950x466x620

Hot Food Display Warmer ⚡

Features

- It's good ideal for the cake showcase, because the temperature only up to 50°C.
- Dual fans circulate air to ensure even temperature control.
- Double glazed hollow glass front adds durability and insulation benefits.
- 10mm glass for side glass for better thermal insulation effect.
- Light strips at the top of the cabinet and beneath the upper shelf offer optimum illumination.
- Rear sliding doors remove for simple cleaning and display changes.



Model	Voltage (V)	Power (kW)	Capacity (L)	Temperature (°C)	Net Weight (kg)	Dimensions (mm)
DH-60	220	0.2	60	50	42	610x480x678
DH-80	220	0.22	95	50	58	905x480x678

Commercial Food Display Warmer

Features

- Internal display light
- Alternative shelf positions
- Element baffle for even heat distribution
- Precise thermostat control
- Toughened safety glass
- Removable glass, shelves and crumb trays for easy cleaning
- Double skin cavity for even temperature and low running costs



Model	Voltage (V)	Power (kW)	Temperature (°C)	Net Weight (kg)	Dimensions (mm)
FW-1	220	1	40~80	21	640x360x530
FW-2	220	1.5	40~80	35	865x360x625

Hot Food Display Warmer

Hot Food Display Warmer ⚡

Features

- High quality compressor and condenser fan motor, durable and reliable.
- Precise digital controller, with big LCD display and inner temperature display.
- Patented electronic expansion valve fan cooling system, energy saving 30%.
- Automatic defrost system
- Independent compressor deck and track type electrical board, easy maintenance.
- Improved slidding doors track and bearing, easy moving and lower noise.
- With both braked castors and adjustable feet.



Model	Voltage (V)	Shelves	Capacity (L)	Temperature (°C)	Net Weight (kg)	Dimensions (mm)
R98FC	220-240	2	115	65	95	900x540x820
R128FC	220-240	2	155	65	105	1200x540x820
R168FC	220-240	2	200	65	125	1500x540x820

Black Mirror Hot Display Showcase ⚡

Features

- Curved glass, luxury style, perfect for displaying pies, pastries etc.
- Four side thick tempered glass, delicious food could be seen all around.
- Edge protected glass doors on metal runners.
- Adjustable shelves with 3 levels, easily to set for large product.
- Equipped with water proof light bulb, makes the food even more attractive.
- 4 rubber feet, ideal for extra stability
- Water tray to keep the food fresh



Without Fever Glass

Model	Voltage (V)	Power (kW)	Capacity (L)	Temperature (°C)	Net Weight (kg)	Dimensions (mm)
LR-WH-730C	220	1.2	100	50~100	60	730x557x677

Food Warmer CE ⚡

Features

- 3 Adjustable Chrome plated Shelves, simple for cleaning
- Toughened glass, With LED light
- Sliding toughened glass doors provide quick, easy access
- With Steam to keep moisture, texture and freshness of food
- Four side thick tempered glass, delicious food could be seen all around
- Adopt fantastic quality thermostat to hold food items at optimum temperature



Model	Voltage (V)	Power (kW)	Capacity (L)	Temperature (°C)	Net Weight (kg)	Dimensions (mm)
FW120L	220	1.1	120	30~90	48	678x568x670
FW150L	220	1.5	160	30~90	56	856x568x670

Hot Food Display Warmer

Hot Food Display Warmer

Features

- Brilliant Internal illumination on sides
- Adjustable temperature controller
- Non-adjustable shelf
- Fixed rubber feet
- Stainless steel
- Front Acrylic hinge door/Sliding doors



RTR-2D-2



RTR-3D

Model	Display Area(m ²)	Power (W)	Temperature Range(°C)	Net Weight (kg)	Dimensions (mm)
RTR-2D-2	0.5	560	30~85	26.5	650X467X630
RTR-3D	145L	1160	30~90	32	648X467X691

Hot Food Display Warmer

Features

- Brilliant Internal LED illumination on top
- Adjustable temperature controller
- Temperature display
- Adjustable chrome plated shelves
- Sliding doors
- Front flat glass



Model	Capacity-GrossW(L)	Power (W)	Temperature Range(°C)	Net Weight (kg)	Dimensions (mm)
RTR-130L-1	130	1100	30-90	34.5	678X578X698
RTR-160L-2	160	1500	30-90	42	857X578X698

Hot Food Display Warmer

Features

- Brilliant internal LED illumination on top
- Adjustable temperature controller
- Temperature display
- Adjustable chrome plated shelves
- Front flat glass
- Front and back sliding doors



Model	Capacity-GrossW(L)	Power (W)	Temperature Range(°C)	Net Weight (kg)	Dimensions (mm)
RTR-125L	125	1100	30-90	36	678X568X686
RTR-165L	165	1500	30-90	51	855X568X686
RTR-205L	205	1800	30-90	60	1219X568X686
RTR-256L	256	1800	30-90	76	1524X568X686

Food Display Warmer

Food Display Warmer

Features

- Brilliant Internal LED illumination on top
- Digital temperature controller and display
- Adjustable chrome plated shelves
- 4 sides double glass
- Front Curved glass
- Sliding doors
- Maintenance free condenser
- Ventilated cooling system
- Automatic defrost
- Stainless steel



RTW-105L



RTW-120L/160L/202L/252L

Model	Capacity -GrossW(L)	Power (W)	Temperature Range(°C)	Refrigerant	Class mate	Net Weight (kg)	Dimensions (mm)
RTW-105L	100	160	0-12	R134a/R600a	4	53.5	695X470X685
RTW-120L	120	230/160	0-12	R134a/R600a	4	57	702X568X686
RTW-160L	160	230/200	0-12	R134a/R600a	4	66	880X568X686
RTW-202L	200	400/360	0-12	R134a/R600a	4	88.5	1219X568X686
RTW-252L	252	460	0-12	R290	4	116	1524X568X686

Food Display Warmer

Features

- Brilliant Internal LED illumination on top
- Digital temperature controller and display
- Adjustable chrome plated shelves
- 4 sides double glass
- Front flat glass
- Maintenance free condenser
- Ventilated cooling system
- Automatic defrost
- Stainless steel
- Sliding doors



Model	Capacity -GrossW(L)	Power (W)	Temperature Range(°C)	Refrigerant	Class mate	Net Weight (kg)	Dimensions (mm)
RTW-120L-3	120	230/160	0-12	R134a/R600a	4	57	702X568X686
RTW-160L-3	160	230/210	0-12	R134a/R600a	4	66	880X568X686
RTW-202L-3	200	400/400	0-12	R134a/R600a	4	90	1219X568X686
RTW-252L-3	252	460	0-12	R290	4	116	1524X568X686

Food Display Warmer

Features

- Brilliant Internal LED illumination on top
- Digital temperature controller and display
- Adjustable chrome plated shelves
- 4 sides double glass
- Front and back sliding doors
- Maintenance free condenser
- Ventilated cooling system
- Automatic defrost
- Stainless steel



Model	Capacity -GrossW(L)	Power (W)	Temperature Range(°C)	Refrigerant	Class mate	Net Weight (kg)	Dimensions (mm)
RTW-125L	125	230/160	0-12	R134a/R600a	4	54	702X568X686
RTW-165L	165	230/210	0-12	R134a/R600a	4	66	880X568X686
RTW-205L	205	400/400	0-12	R134a/R600a	4	90	1219X568X686
RTW-256L	256	460	0-12	R290	4	116	1524X568X686



Potato Chips Worker

- All stainless steel body
- Easy and convenient operation
- Display and warm chips, Multicolor light for good display effect
- Keep temperature by infrared ray
- The equipment adopts infrared lamp and heating tube infrared heat, heat preservation and lighting for food



DH-6P With humidity convection system



WS-02

Model	Voltage (V)	Power (kW)	Temperature (°C)	Net Weight (kg)	Dimensions (mm)
DH-6P-L	220	2.9	30~85	112	1550x810x885
DH-6P	220	3.5	30~85	112	1500x750x860
DH-6P-B	220	2	30~85	94	1200x750x860
WS-02A	220	-	-	50	1200x760x800
WS-02	220	-	-	65	1500x760x800
WS-04	220	-	-	80	1800x760x800

Potato Chips Worker

- All stainless steel body
- Easy and convenient operation
- Display and warm chips, Multicolor light for good display effect
- Keep temperature by infrared ray
- The equipment adopts infrared lamp and heating tube infrared heat, heat preservation and lighting for food



VF-8S



VF-60



VF-10

Model	Voltage (V)	Power (kW)	Temperature (°C)	Net Weight (kg)	Dimensions (mm)
VF-8S	220	0.971	30~50	20	800x500x600
VF-60	220	0.75	30~85	45	600x770x1570
VF-10	220	1	30~85	85	1050x770x1570

Freestanding Infrared Fry Warmer

Features

- All stainless steel construction
- A simple rocker switch controls the heat and the lights, making it easy for any employee to operate the dump stationBase includes food pan
- Heat and light display,keep your French fries hot, crisp, and ready to serve at all times



Model	Voltage (V)	Power (kW)	Temperature (°C)	Net Weight (kg)	Dimensions (mm)
EHS-330	220	0.6	80	5.5	340x565x420
EHS-660	220	1	100	13	860x370x420

2 Bulb Food Warmer

Features

- This warmer boasts a simple design that combines with a rugged construction to give you a reliable way to keep fried foods hot without drying them out so they always taste like they just came out of the fryer
- Adjustable height,you can control the intensity of the heat and prevent over-drying
- A aluminum construction give this free standing heat lamp exceptional durability



Model	Voltage (V)	Power (kW)	Temperature (°C)	Net Weight (kg)	Dimensions (mm)
BV-BWD-2	220	0.5	50	2.8	380x480x560
BV-BWZ-2	220	2+0.5	50	12	730x500x700

3&4 Bulb Food Warmer

Features

- This warmer boasts a simple design that combines with a rugged construction to give you a reliable way to keep fried foods hot without drying them out so they always taste like they just came out of the fryer
- Adjustable height,you can control the intensity of the heat and prevent over-drying
- A aluminum construction give this free standing heat lamp exceptional durability



Model	Voltage (V)	Power (kW)	Temperature (°C)	Net Weight (kg)	Dimensions (mm)
BV-BWZ-3	220	2+0.75	50	16	1070x500x700
BV-BWZ-4	220	2+1	50	21	1370x500x700

Oil Filter Cart & Bolating Machine & Wrapping Powder Table

Oil Filter Cart

- Stainless steel body, more durable
- Equipped with a slag separator, which can effectively filter out relatively large oil residues and leave them in the net for easy cleaning
- The oil suction pipe is connected to the oil filter paper. When the power is turned on to pump oil, the oil filter paper can further filter the oil residue again.
- Equipped with an oil discharge valve, the remaining oil or water can be drained through this valve when cleaning or cleaning.
- High temperature resistant tubing, in line with food safety, can be filtered while hot



Model	Voltage (V)	Power (kW)	-	Net Weight (kg)	Dimensions (mm)
LU-400	220	0.5	220Kg liter/min 0.33mpa	50	450x800x750

Bolating Machine

- Made of stainless steel, clean, hygienic and durable
- Large space work area, more convenient to operate
- Detachable design for easy transportation



Model	Voltage (V)	Power (kW)	Net Weight (kg)	Dimensions (mm)
VBM-617	220	0.37	44	930x470x1000

Wrapping Powder Table

- The food is rotated and squeezed in the drum, make the sauce into the food more fully
- Stainless steel body, more hygienic and durable
- Cooling plate waterproof design, safe to use
- Thickened sealing cover design, no air leakage and no sauce leakage
- Come with casters for easy mobility



Model	Net Weight (kg)	Dimensions (mm)
VW-88	33.5	1000x700x1000

Cup Warmer & Dish Dispenser

Cup Warmer

Features

- Stainless steel construction
- Easy to clean
- Each layer are separated control
- 170mm height for each layer
- 550x338mm for each layer heating area



Model	Voltage (V)	Power (kW)	Net Weight (kg)	Dimensions (mm)
LR-OT-346	220	1.5	18	340x550x860

Heated Dish Dispenser

Features

- Used to dispense dishes, cups, glasses, bowls, plate covers and other round dinnerware. This tube-type, self-leveling dispenser is easily installed in serving counters, back bars, and other service points.
- Plate after one hour in heated tube, depending on temperature of plates when placed in tube
- Each holder Maximum capacity for all units is to six dozen dishes.
- Suitable for 8-12" diameter plate
- Heating system keeps dishes warm to the touch
- Stainless steel construction



Model	Voltage (V)	Power (kW)	Net Weight (kg)	Dimensions (mm)
DR-3	220	0.4	19	φ405x725

Heat Dish Dispenser

Features

- Used to dispense dishes, cups, glasses, bowls, plate covers and other round dinnerware.
- This tube-type, self-leveling dispenser is easily installed in serving counters, back bars, and other service points.
- Plate after one hour in heated tube, depending on temperature of plates when placed in tube
- Each holder Maximum capacity for all units is to six dozen dishes.
- Suitable for 8-12" diameter plate
- Heating system keeps dishes warm to the touch
- Stainless steel construction
- The Temperature is from 30°C to 50°C



DR-1



DR-2

Model	Voltage (V)	Power (kW)	Net Weight (kg)	Dimensions (mm)
DR-1	220	0.4	31	450x485x940
DR-2	220	0.4x2	48	450x910x940

Soup Warming Kettle

Soup Warming Kettle ⚡

Features

- convenient and affordable, with a strong focus on health and safety.
- Made from 304 stainless steel, safe and healthy.
- The electric soup pot is used as a heating element, heating soup and any food contained within it.
- It's exquisite workmanship ensures that this product is durable.



Model	Voltage (V)	Power (kW)	Net Weight (kg)	Capacity (L)	Temperature (°C)	Dimensions (mm)
SB-6000	220	0.4	4.8	10	35~95	340x340x395
SB-6000A	220	0.6	5.3	13	35~95	400x400x320
SB-6000S	220	0.4	4.7	9	35~95	340x340x395

Soup Warming Kettle ⚡

Features

- Uniformly heats its contents quickly.
- Can hold a large volume of independent soup, and can cook 1 or 2 soups separately.
- Independent temperature regulation, a simple operation and energy saving.
- Uniform heating, a heat insulating effect and the large capacity of the deep and thick soup pots can also add to the insulation.
- The construction of the whole machine is of thick stainless steel, resulting the machine having a long life.



Model	Voltage (V)	Power (kW)	Net Weight (kg)	Capacity (L)	Temperature (°C)	Dimensions (mm)
LR-RBM-1	220	0.8	9.5	11	0~85	407x450x327
LR-RBM-2	220	1.5	15.6	11x2	0~85	810x455x327

Electric Bain Marie

Electric Bain Marie ⚡

Features

- Stainless steel construction
- Tap for easy drainage
- Wet heat only operation
- Drain tap for fast, safe cleaning
- The wire with Plug
- Easy to clean
- Insulated faucet handle



Model	Power (kW)	Voltage (V)	Temperature (°C)	Specification	Depth of Pan (mm)	Net Weight (kg)	Dimensions (mm)
BM150-1B	1.2	220	0~90	GN1/1x1	150	10.05	570x370x240
BM150-2B	1.2	220	0~90	GN1/2x2	150	10.32	570x370x240
BM150-3B	1.2	220	0~90	GN1/3x3	150	10.55	570x370x240

Electric Bain Marie (Pans are not included) ⚡

Features

- Stainless steel construction
- Tap for easy drainage
- Wet heat only operation
- Stainless steel construction
- Tap for easy drainage
- Wet heat only operation

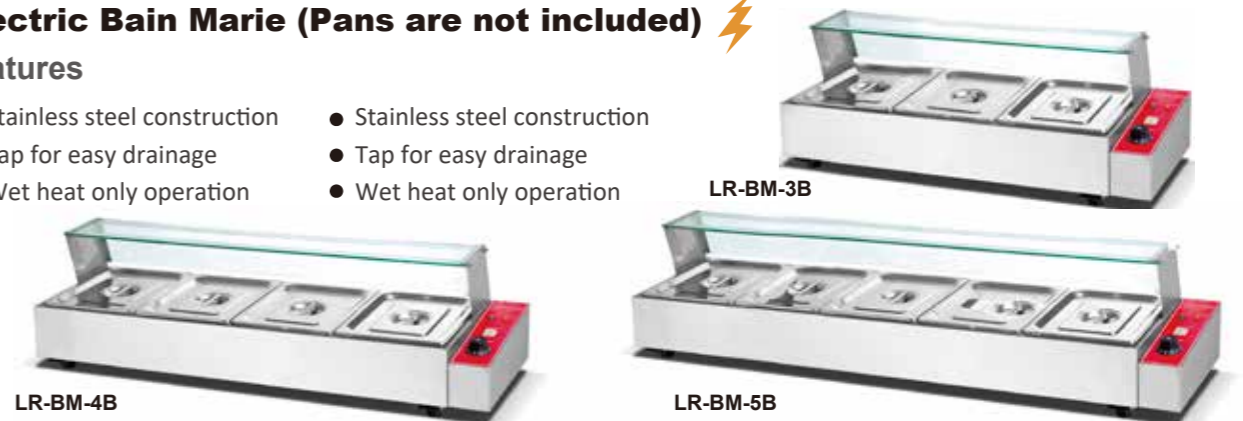

Model	Power (kW)	Voltage (V)	Temperature (°C)	Specification	Depth of Pan (mm)	Net Weight (kg)	Dimensions (mm)
LR-BM-3B	1.5	220	30~85	GN1/2 x3	100	13.5	920x350x340
LR-BM-4B	1.5	220	30~85	GN1/2x4	100	17	1185x350x340
LR-BM-5B	1.8	220	30~85	GN1/2x5	100	20	1450x350x340

Electric Bain Marie ⚡

Features

- Stainless steel construction
- Tap for easy drainage
- Wet heat only operation
- Drain tap for fast, safe cleaning
- The wire with Plug
- Easy to clean
- Insulated faucet handle



Model	Power (kW)	Voltage (V)	Temperature (°C)	Specification	Depth of Pan (mm)	Net Weight (kg)	Dimensions (mm)
BS-2TB	0.8	220	30~85	GN1/2x2	100	12	550x400x300
BS-4TB	1.5	220	30~85	GN1/2x4	100	20	694x565x240
BS-6TB	1.8	220	30~85	GN1/2x6	100	25	1035x590x240
BS-8TB	1.8	220	30~85	GN1/2x8	100	30	1355x565x240

Bain Marie

Electric Bain Marie ⚡

Features

- Stainless steel construction
- Tap for easy drainage
- Wet heat only operation
- Drain tap for fast, safe cleaning
- The wire with Plug
- Easy to clean
- Insulated faucet handle



BM1200C



BM1500C



BM1800C

Model	Power (kW)	Voltage (V)	Temperature (°C)	Specification	Depth of Pan (mm)	Net Weight (kg)	Dimensions (mm)
BM1200C	0.2	220	2~8	GN1/2x1+GN1/3x3	150	43	1200x380x430
BM1500C	0.2	220	2~8	GN1/2x1+GN1/3x5	150	52	1500x380x430
BM1800C	0.2	220	2~8	GN1/3x8	150	58	1800x380x430

BV Bain Marie ⚡

Features

Ideal for home and commercial use such as cafeterias, banquet halls and restaurants.

- Stainless steel construction
- Thermostat control knob
- Indicator Lights
- Gastronorm containers included
- Durable, heavy duty food warmer



BV-63



BV-64



BV-65



Model	Power (kW)	Voltage (V)	Temperature (°C)	Specification	Depth of Pan (mm)	Net Weight (kg)	Dimensions (mm)
BV-63	2.3	220	30~80	GN1/2 x6	65	44	1060x680x700
BV-64	2.8	220	30~80	GN1/2 x8	65	59	1400x680x700
BV-65	2.9	220	30~80	GN1/2 x10	65	70	1730x680x700
BV-66	2.9	220	30~80	GN1/1 x6	100	75	2070x680x700

Bain Marie

BV Bain Marie ⚡

Features

Ideal for home and commercial use such as cafeterias, banquet halls and restaurants.

- Stainless steel construction
- Thermostat control knob
- Indicator Lights
- Depth of Pan: 100mm
- Gastronorm containers included
- Durable, heavy duty food warmer
- Temperature range 30-80°C



Model	Power (kW)	Voltage (V)	Temperature (°C)	Specification	Net Weight (kg)	Dimensions (mm)
BV6-1	2.5	220	GN1/2x6	30~80	83	1070x650x850
BV8-1	2.5	220	GN1/2x8	30~80	103	1400x650x850
BV10-1	2.5	220	GN1/2x10	30~80	123	1730x650x850
BV12-1	2.5	220	GN1/2x12	30~80	143	2060x650x850

BV Bain Marie ⚡

Features

Ideal for home and commercial use such as cafeterias, banquet halls and restaurants.

- Stainless steel construction
- Thermostat control knob
- Indicator Lights
- Depth of Pan: 100mm
- Gastronorm containers included
- Durable, heavy duty food warmer
- Temperature range 30-80°C



Model	Power (kW)	Voltage (V)	Temperature (°C)	Specification	Net Weight (kg)	Dimensions (mm)
BV6-2	2.5	220	GN1/1x3+GN1/1x3	30~80	88	1070x650x850
BV8-2	2.5	220	GN1/1x4+GN1/1x4	30~80	108	1400x650x850
BV10-2	2.5	220	GN1/1x5+GN1/1x5	30~80	129	1730x650x850
BV12-2	2.5	220	GN1/1x6+GN1/1x6	30~80	151	2060x650x850

BV Bain Marie ⚡

Features

Ideal for home and commercial use such as cafeterias, banquet halls and restaurants.

- Stainless steel construction
- Thermostat control knob
- Indicator Lights
- Gastronorm containers included
- Durable, heavy duty food warmer



Model	Power (kW)	Voltage (V)	Temperature (°C)	Specification	Depth of Pan (mm)	Net Weight (kg)	Dimensions (mm)
BV-57	2.5	220	30~80	GN1/1x4 or GN1/2x8	100	37	1500x700x850
BV-58	2.5	220	30~80	GN1/1x5 or GN1/2x10	100	44	1900x700x850
BV-59	2.5	220	30~80	GN1/1x6 or GN1/2x12	100	51	2200x700x850

BV Bain Marie ⚡

Features

Ideal for home and commercial use such as cafeterias, banquet halls and restaurants.

- Stainless steel construction
- Thermostat control knob
- Indicator Lights
- Gastronorm containers included
- Durable, heavy duty food warmer



Model	Power (kW)	Voltage (V)	Temperature (°C)	Specification	Depth of Pan (mm)	Net Weight (kg)	Dimensions (mm)
BV-60	2.5	220	30~80	GN1/1x4 or GN1/2x8	100	70	1500x700x850
BV-61	2.5	220	30~80	GN1/1x5 or GN1/2x10	100	88	1900x700x850
BV-62	2.5	220	30~80	GN1/1x6 or GN1/2x12	100	102	2200x700x850



BV Kitchenware Equipment

Features

Ideal for home and commercial use such as cafeterias, banquet halls and restaurants.

- Stainless steel construction
- Thermostat control knob
- Indicator Lights
- Gastronorm containers included
- Durable, heavy duty food warmer
- Temperature range 30-85°C

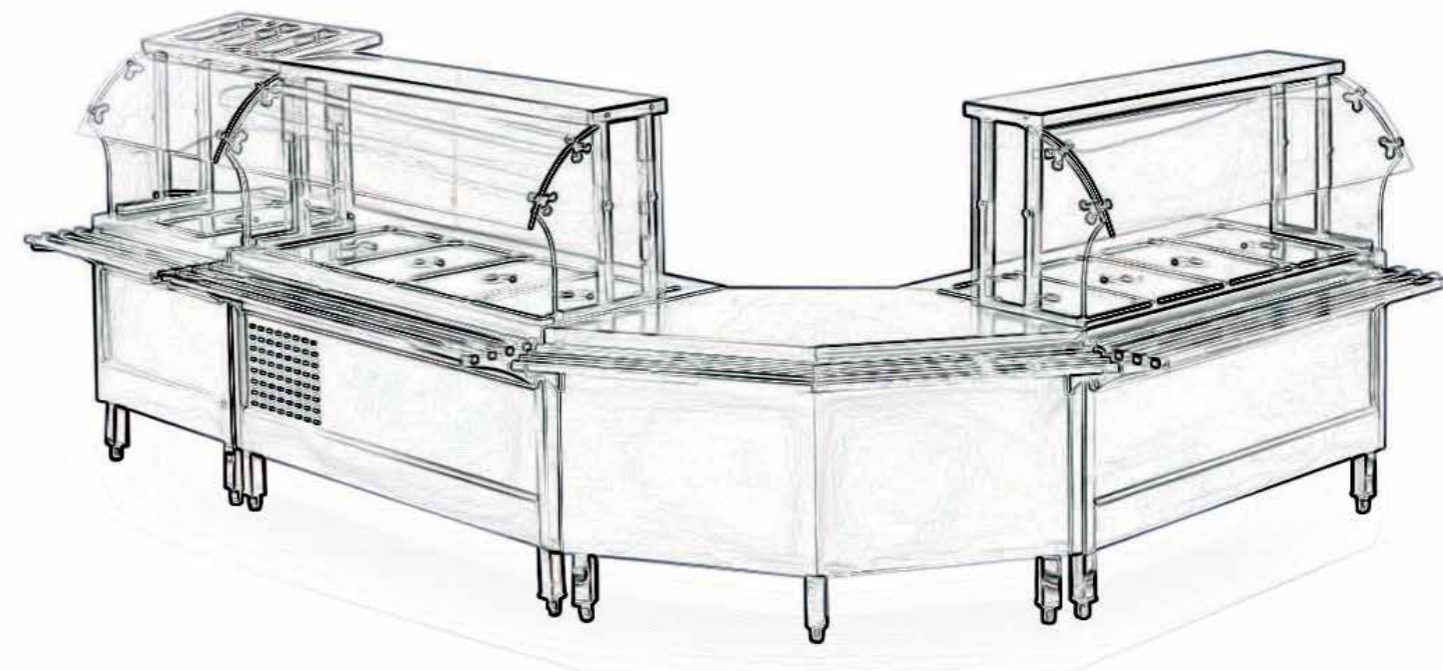

BV Kitchenware Equipment ⚡

Features

Ideal for home and commercial use such as cafeterias, banquet halls and restaurants.

- Stainless steel construction
- Thermostat control knob
- Indicator Lights
- Gastronorm containers included
- Durable, heavy duty food warmer



Model	Voltage (V)	Power (kW)	Depth of Pan (mm)	Temperature (°C)	Net Weight (kg)	Dimensions (mm)	Specification
BV-54C/4	220	0.32	100	0~8	125	1500x950x(850+600)	GN1/1x4

BV Kitchenware Equipment ⚡

Features

Ideal for home and commercial use such as cafeterias, banquet halls and restaurants.

- Stainless steel construction
- Thermostat control knob
- Indicator Lights
- Gastronorm containers included
- Durable, heavy duty food warmer



Model	Voltage (V)	Power (kW)	Depth of Pan (mm)	Temperature (°C)	Net Weight (kg)	Dimensions (mm)	Specification
BV-54	220	2.5	100	30~80	90	1500x950x(850+600)	GN1/1x4 or GN1/2x8
BV-55	220	2.5	100	30~80	114	1900x950x(850+600)	GN1/1x5 or GN1/2x10
BV-56	220	2.5	100	30~80	132	2200x950x(850+600)	GN1/1x6 or GN1/2x12

BV Kitchenware Equipment ⚡

Features

Ideal for home and commercial use such as cafeterias, banquet halls and restaurants.

- Stainless steel construction
- Thermostat control knob
- Indicator Lights
- Gastronorm containers included
- Durable, heavy duty food warmer



Model	Voltage (V)	Power (kW)	Depth of Pan (mm)	Temperature (°C)	Net Weight (kg)	Dimensions (mm)	Specification
BV-56-8	220	0.32	100	0~8	260	1500x1400x1550	GN1/1x8

Buffet Case

Features

Ideal for home and commercial use such as cafeterias, banquet halls and restaurants.

- Stainless steel construction
- Thermostat control knob
- Indicator Lights
- Gastronorm containers included
- Durable, heavy duty food warmer



Model	Specification	Depth of Pan (mm)	Net Weight (kg)	Dimensions (mm)
BV-54C	GN1/1x1	100	47	800x950x(850+600)

Buffet Case

Features

Ideal for home and commercial use such as cafeterias, banquet halls and restaurants.

- Stainless steel construction
- Thermostat control knob
- Indicator Lights
- Gastronorm containers included
- Durable, heavy duty food warmer



Model	Power (kW)	Voltage (V)	Temperature (°C)	Specification	Depth of Pan (mm)	Net Weight (kg)	Dimensions (mm)
BV-54A	2.5+1.1	220	30~80	GN1/1x4	100	109	1520x960x(900+700)
BV-55A	2.5+1.375	220	30~80	GN1/1x5	100	130	1820x960x(900+700)
BV-56A	2.5+1.65	220	30~80	GN1/1x6	100	152	2130x960x(900+700)

Buffet Case

Features

Ideal for home and commercial use such as cafeterias, banquet halls and restaurants.

- Stainless steel construction
- Thermostat control knob
- Indicator Lights
- Gastronorm containers included
- Durable, heavy duty food warmer



Model	Net Weight (kg)	Dimensions (mm)
BV-54B	48	1450x(820+250)x850

Glass Washing Machine

Features

- Suitable for hotels and restaurants
- Contact area is large, leaving a high cleaning efficiency
- Before use, the device must be left to dry overnight.
- Only requires 3-4s to clean cups, improving work efficiency and save on labour costs.
- High efficiency and energy saving, greatly improve the circulation utilization of the cup.
- To save time, save water, energy conservation and environmental protection



Model	Voltage (V)	Power (κW)	Speed (r/min)	Net Weight (kg)	Dimensions (mm)
SB-1	220	0.25	2750	7	200x300x250

Glass Dryer and Polisher

Feature

- High efficiency and great energy saving ability, improving the circulation utilisation of the cup.
- Saves time, water, energy, saving money and lessening the impact on the environment.
- Professional Polishing - the brushes are made of natural, absorbent fiber and are suitable for all types of cups and glasses
- Hot Air Drying - dries quickly and hygienically
- Stainless steel construction
- Production: 240-360 pieces/hour



Model	Voltage (V)	Power (kW)	Speed (r/min)	Net Weight (kg)	Dimensions (mm)
GD-5	220	1.1	1400	20	342x312x563
GD-8	220	2.0	1400	29	342x468x563

Knife Sterilizer

Feature

- Vertical wall hanging dual-purpose fashion, high-grade atmosphere!
- Characteristics of the production quality include a double-layer tempered glass, handling high temperatures up to 125°C, sensitive temperature control, automatic power-off device,
- Uses a high tech microcomputer chip with plastic integrated hidden handles, with a stainless steel shell/liner, bold electroplating anti-rust layer frame and a simple piano type touch key design.



Model	Voltage (V)	Power (W)	Net Weight (kg)	Dimensions (mm)
DX-1	220	20	8	400x150x615
DX-2	220	30	12	400x300x615



Under Table Dish washer

Features

- Up and down rotary washing and rinsing, cover the tableware in all directions to ensure the cleaning effect.
- The energy consumption is reduced by more than 20-30% compared with the traditional one.
- Key operation panel
- The unique design of the mezzanine door has both the functions of heat preservation and heat insulation, and effectively reduces noise.
- The machine is made of stainless steel 304, and all spare parts are selected from high-quality products at home and abroad. High-efficiency Italian water pump ensures washing power.
- Fully enclosed bottom plate, insect-proof and rat-proof design.

Installation requirements:

Switch: >32A

Inlet pipe diameter: 4 minutes outer wire (DN15)

Drain pipe diameter: φ40

Water inlet pressure: 0.15-0.6Mpa

Inlet water temperature: 10°C~60°C

Inlet water hardness: <50mg/L



	UD-50
Voltage	380V 3 phase
Power	7.4kW
Washing Heating Power	1kW
Rinse Heating Power	6kW
Washing Pump Power	0.37kW
Washing Temperature	55~65°C
Rinse temperature	80~90°C
Washing Capacity	50 Racks/h
Water Consumption	2.3L/Rack
Dimensions	570x620x796mm

Dish Washer

Features

- Suitable for all kinds of restaurants, cafes, canteen, etc.
- Mechanical circuit control panel, easy to operate, external digital temperature display, start indicator light, so that the machine running status is clear at a glance.
- Independent washing spray arm and rinsing spray arm, easy to clean and easy to load and unload.
- The unique design of the door can stay at different heights and is suitable for different types of tableware.
- Sensitive door control switch, which can be washed immediately after closing the door, which is safe and convenient.
- The advanced float device can accurately control the water level to a reliable height and protect the heater at all times.
- Use circulating water for the initial washing stage, saving washing water consumption, environmental protection and energy saving.
- The washing arm adopts the concave anti-blocking spray design, high-speed rotation 360-degree rotating fan-shaped water spray form, expands the spray washing range, and has super cleaning ability to ensure a perfect washing effect.
- Optional bench and sink.



Optional accessories



C88	
Capacity	100 Piece/h 60 Racks/h
Total Electrical Voltage	380V 50Hz
Main Wash Tank Power	3kw
High Temperature Tank Power	9kw
Total Electrical Power	13kw
Max Water Consumption	180L/Hour
Main Wash Tank Capacity	30L
High Temperature Tank Capacity	7L
Water Inlet Pressure	1-3(kg/cm ²)
Tank Temp.	50~70 C
Temp.Boiler	75~95 C
Net Weight	120kg
Door Entry Height	400mm
Height When Open Machine	1750mm
Dimensions	640x710x1400mm

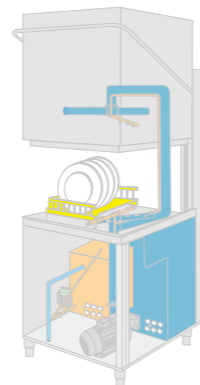
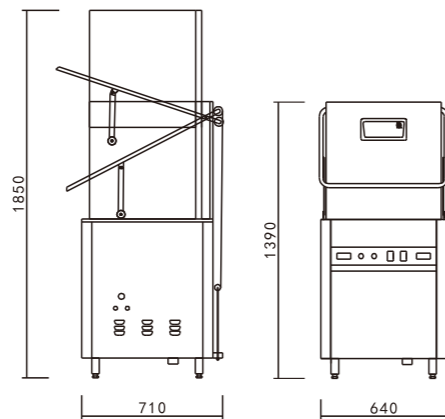

Dish Washer

Features

- Tunnel type (basket transmission type) transmission design, implements the cleaning method of "advance 2 retreat 1" to ensure all-round spray cleaning.
- When the dishwasher is running, once the detection door is accidentally opened, the water pump and transmission motor will be automatically turned off immediately to prevent hot water from splashing, which is safe and comfortable.
- High-quality temperature control function to ensure that the rinsing water temperature reaches above 85 degrees to achieve the best results
- The end of the optional outlet table is equipped with an automatic shutdown protection device to prevent the tableware from being damaged due to not being unloaded in time, saving time and worry.
- Use circulating water for the initial washing stage, saving washing water consumption, environmental protection and energy saving.
- When the tableware enters the high temperature spray area, the spray system is automatically turned on to achieve the effect of energy saving.
- The washing arm adopts the concave anti-blocking nozzle design, 60° fan-shaped water spray form, expands the spray washing range, and has super cleaning ability to ensure perfect washing effect.



Optional accessories



C100	
Capacity	2600 Piece/h 130 Racks/h
Total Electrical Voltage	380V 50Hz
Main Wash Tank Power	9kw
High Temperature Tank Power	27kw
Total Electrical Power	37kw
Max Water Consumption	360L/Hour
Main Wash Tank Capacity	98L
High Temperature Tank Capacity	30L
Water Inlet Pressure	1-3(kg/cm ²)
Tank Temp.	50~70 C
Temp.Boiler	75~95 C
Net Weight	233kg
Door Entry Height	400mm
Height When Open Machine	2100mm
Dimensions	1160x780x1600mm

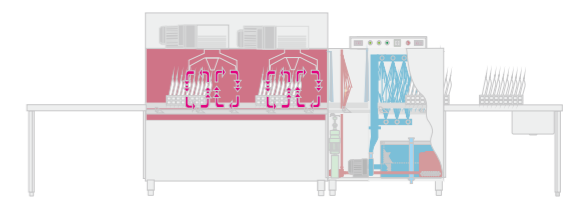

Machine Direction - Right In, Left Out

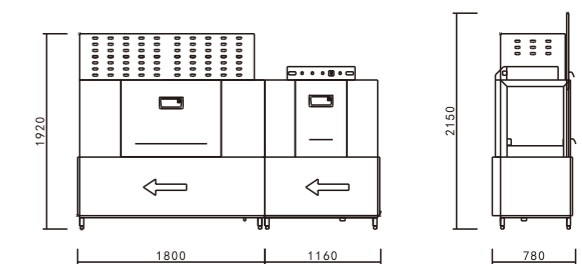

Dish Washer Features

- Tunnel type (basket transmission type) transmission design, implements the cleaning method of "advance 2 retreat 1" to ensure all-round spray cleaning.
- When the dishwasher is running, once the detection door is accidentally opened, the water pump and transmission motor will be automatically turned off immediately to prevent hot water from splashing, which is safe and comfortable.
- High-quality temperature control function to ensure that the rinsing water temperature reaches above 85 degrees to achieve the best results
- The end of the optional outlet table is equipped with an automatic shutdown protection device to prevent the tableware from being damaged due to not being unloaded in time, saving time and worry.
- Use circulating water for the initial washing stage, saving washing water consumption, environmental protection and energy saving.
- When the tableware enters the high temperature spray area, the spray system is automatically turned on to achieve the effect of energy saving.
- The washing arm adopts the concave anti-blocking nozzle design, 60° fan-shaped water spray form, expands the spray washing range, and has super cleaning ability to ensure perfect washing effect.

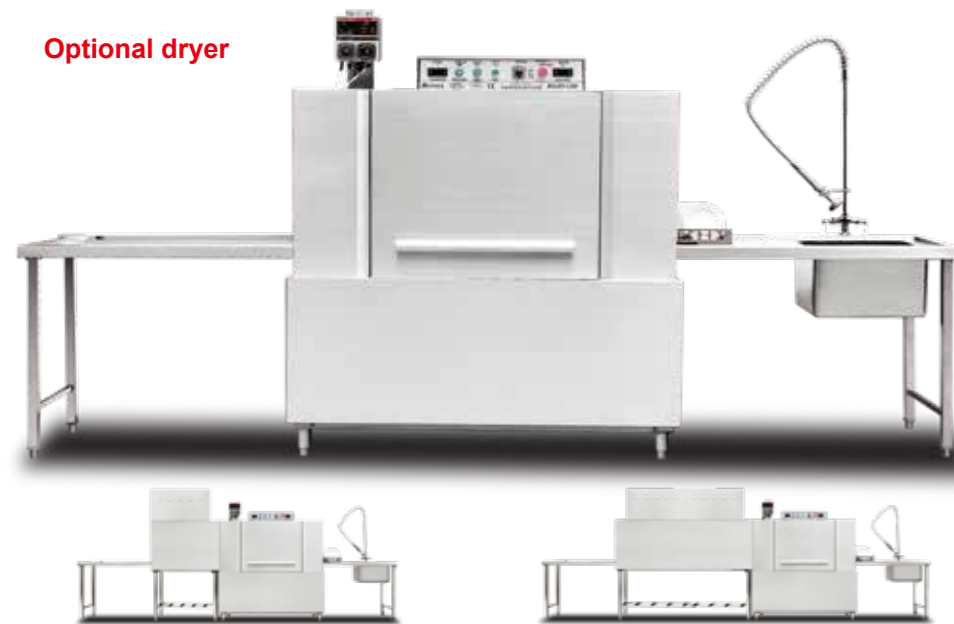

Optional accessories



C180	
Capacity	3700 Piece/h 185 Racks/h
Total Electrical Voltage	380V 50Hz
Main Wash Tank Power	9kw
High Temperature Tank Power	27kw
Total Electrical Power	37kw
Max Water Consumption	360L/Hour
Main Wash Tank Capacity	98L
High Temperature Tank Capacity	30L
Water Inlet Pressure	1-3(kg/cm ²)
Tank Temp.	50~70 C
Temp.Boiler	75~95 C
Net Weight	318kg
Door Entry Height	400mm
Height When Open Machine	2100mm
Dimensions	1500x780x1600mm

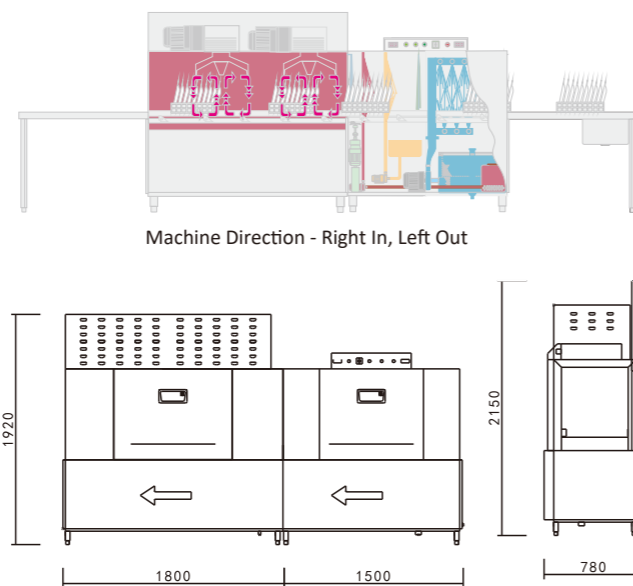

Dish Washer Features

- Tunnel type (basket transmission type) transmission design, implements the cleaning method of "advance 2 retreat 1" to ensure all-round spray cleaning.
- When the dishwasher is running, once the detection door is accidentally opened, the water pump and transmission motor will be automatically turned off immediately to prevent hot water from splashing, which is safe and comfortable.
- High-quality temperature control function to ensure that the rinsing water temperature reaches above 85 degrees to achieve the best results
- The end of the optional outlet table is equipped with an automatic shutdown protection device to prevent the tableware from being damaged due to not being unloaded in time, saving time and worry.
- Use circulating water for the initial washing stage, saving washing water consumption, environmental protection and energy saving.
- When the tableware enters the high temperature spray area, the spray system is automatically turned on to achieve the effect of energy saving.
- The washing arm adopts the concave anti-blocking nozzle design, 60° fan-shaped water spray form, expands the spray washing range, and has super cleaning ability to ensure perfect washing effect.



Optional accessories

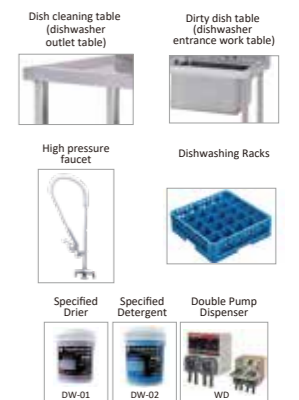

C250	
Capacity	5000 Piece/h 250 Racks/h
Total Electrical Voltage	380V 50Hz
Main Wash Tank Power	9kw
High Temperature Tank Power	27kw
Total Electrical Power	42kw
Max Water Consumption	360L/Hour
Main Wash Tank Capacity	2x140L
High Temperature Tank Capacity	30L
Water Inlet Pressure	1-3(kg/cm ²)
Tank Temp.	50~70 C
Temp.Boiler	75~95 C
Net Weight	378kg
Door Entry Height	400mm
Height When Open Machine	2100mm
Dimensions	2190x780x1600mm

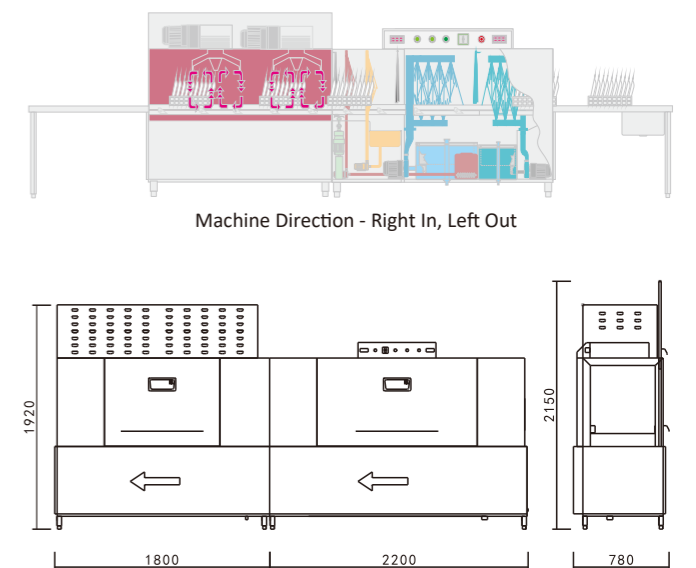

Faucet



LB-128A
 Open aperture 35mm
 2/1 of the outer teeth
 6" long fixed wall bracket
 Additional swing the tap water to wash the hands
 the total height of about 1000mm

LB-128
 Open aperture 35mm
 2/1 of the outer teeth
 6" long fixed wall bracket
 the total height of about 1000mm

LB-138A
 Open aperture 25mm
 2/1 of the outer teeth
 12" long fixed wall bracket
 Additional swing the tap water to wash the hands
 the total height of about 1000mm

LB-138
 Open aperture 25mm
 2/1 of the outer teeth
 12" long fixed wall bracket

LB-188A
 Open aperture 35mm
 2/1 of the outer teeth of hot and cold water joint
 12" long fixed wall bracket
 the total height of about 1000mm

LB-016
 Open aperture 25mm
 12" long fixed wall bracket
 the total height of about 1000mm

JC-1181S-10
JC-1181S-10T
JC-1181S-10T+Y

- 304# polished stainless steel surface treatment
- The gun style
- Adjustable shape and pressure washing water
- High temperature 120 degree steel wire braided
- Hydraulic hose, 20mm diameter hole 3/8 inch
- Length of 5m~10m, 8 length distance location
- Turntable diameter 360mm length 490mm
- 1/2 external tooth copper joint
- The base angles to adjust the position of the turntable



JC-1181S-10
JC-1181S-10T
JC-1181S-10T+Y

JC-1150F-10
JC-1150F-10T
JC-1150F-10T+Y

- Showerhead design
- Low carbon steel spray surface treatment
- High temperature 120 degree steel wire braided
- Hydraulic hose, 20mm diameter hole 3/8 inch
- Length of 5m~10m, 8 length distance location
- Turntable diameter 360mm length 490mm
- 1/2 external tooth copper joint
- The base angles to adjust the position of the turntable



JC-1150F-10
JC-1150F-10T
JC-1150F-10T+Y

The pipe can be easily used to hold the pipe tensile, recyclable
 Simple installation, beautiful and sturdy product,
 convenient use, greatly saves the space
 Flushing effect can reach more than 100 square

Glass Racks

Open Inside Compartments

Particular wave patterns and open inside compartments ensure thorough washing, and advance air circling to dry inside faster.

Glass Racks

The racks fit through any commercial dishwasher. Seven different rack specifications are available. The rack is the perfect tool for holding large plates during washing cycles.

Comfortable Handling

Easy-to-grip. Tough handles with texturing on four sides provide comfortable handling.

Steady Construction

Clever structure design bring extra convenience of packing and stacking.

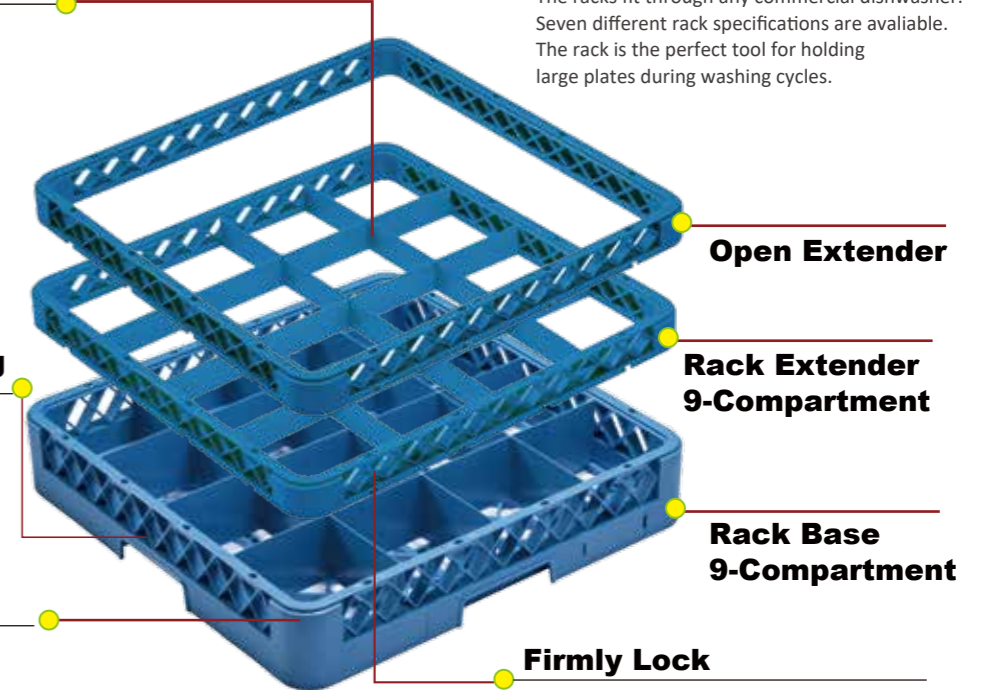

Firmly Lock

The well cutting snap-fit could lock the layers firmly. More safety for shipping and stacking.

Glass Racks (500 x 500mm)

9-Compartment

Maximum Glass Diameter 152mm

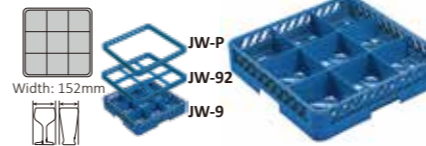

Item No.	Description	Height	Ctn Qty
JW-9	Rack	100mm	6
JW-92	Extender	45mm	6

16-Compartment

Maximum Glass Diameter 115mm



Item No.	Description	Height	Ctn Qty
JW-16	Rack	100mm	6
JW-162	Extender	45mm	6

25-Compartment

Maximum Glass Diameter 90mm

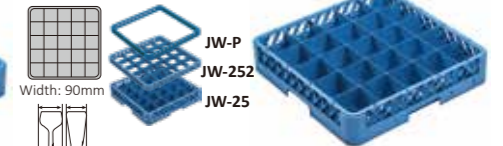

Item No.	Description	Height	Ctn Qty
JW-25	Rack	100mm	6
JW-252	Extender	45mm	6

36-Compartment

Maximum Glass Diameter 75mm

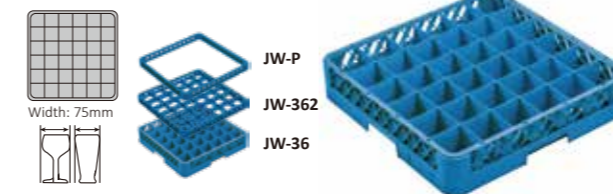

Item No.	Description	Height	Ctn Qty
JW-36	Rack	100mm	6
JW-362	Extender	45mm	6

49-Compartment

Maximum Glass Diameter 65mm

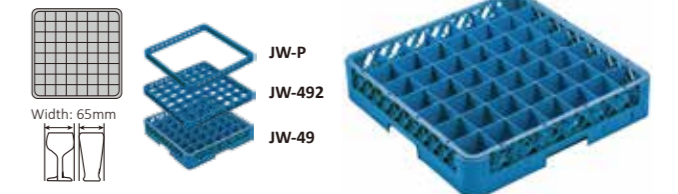

Item No.	Description	Height	Ctn Qty
JW-49	Rack	100mm	6
JW-492	Extender	45mm	6

(500 x 500mm)

20-Compartment Glass Racks

Maximum Glass Diameter 115mm

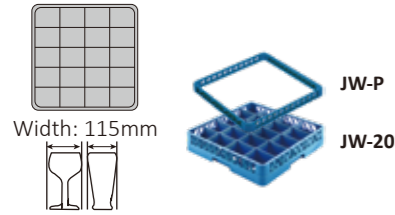

Item No.	Description	Height	Ctn Qty
JW-9	Rack	100mm	6

25-Compartment Plate Rack

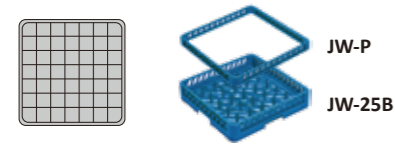

Item No.	Description	Height	Ctn Qty
JW-25B	Rack	100mm	6

25-Compartment Open Plate Rack

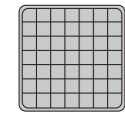

Item No.	Description	Height	Ctn Qty
JW-25P	Open Rack	100mm	6

64-Compartment Plate Rack

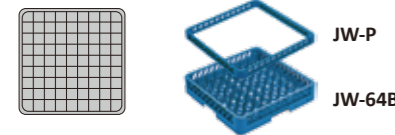

Item No.	Description	Height	Ctn Qty
JW-64B	Rack	100mm	6

64-Compartment Open Plate Rack

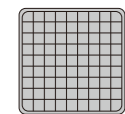

Item No.	Description	Height	Ctn Qty
JW-64P	Open Rack	100mm	6

Open Rack

500 x 500mm

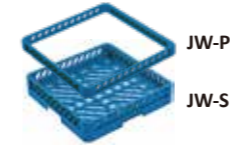

Item No.	Description	Height	Ctn Qty
JW-S	Rack	100mm	6

Cutlery Rack

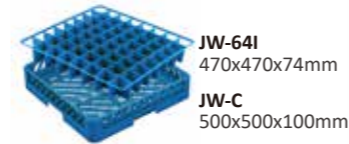

Item No.	Description	Height	Ctn Qty
JW-C	Rack	100mm	6
JW-64I	Inser Rack	74mm	6

Open Extender

500 x 500mm

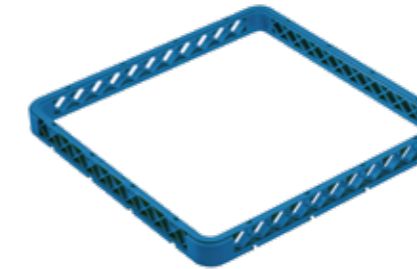

Item No.	Description	Height	Ctn Qty
JW-P	Extender	45mm	16

Cutlery Basket

JW-8B No Handles
JW-8BH With Handles
Overall Size 427x208x151mm
Comp. Size 90x90x110mm
Ctn Qty: 12



Cutlery Box

JW-4C
Overall Size 520x290x100mm
Comp. Size 240x110x75mm
Ctn Qty: 12



Rack Dolly



Item No.	Description	Ctn Qty
JW-RT	540x540x170mm No Handles	1
JW-ST	540x540x773mm With Handles	1

Beige
Material: S/S 、 PP

Semi Automatic Coffee Maker

HC Commercial Coffee Grinder

Features

- Commercial coffee grinder with All Aluminum alloy casted dispenser, right/left hand handle.
- Extra wide dosing capability from as low as 5gr to 10+gr per dose.
- Specially hardened tooling steel grindstones
- Micro adjust table for accurate grinding
- 3 optional colors: Black Red and Silver
- Semi Automatic (T): Timer (max. 5 minutes) control
- Grinding stones diameter:64mm (flat type)
- Certifications:CE, Sanitation listed



Model	Voltage (V)	Power (κW)	Bean Hopper Capacity (kg)	Grinding capacity (kg/h)	Dispenser capacity (g)	Dispensing capacity (g/cup)	Net Weight (kg)	Dimensions (mm)
HC	220	0.35	90	1.8	250	250	12.7	300x210x560

Semi Automatic Coffee Maker

Features

- 304 stainless steel manufacturing and spraying surface; Built-in suction water circulation and water capacity measurement system, always keep the water pressure stable.
- Design of mother and son double boilers, stable outlet water and outlet gas.
- Automatic air supply system, equipped with buttons that can continuously discharge water.
- PID precision temperature control system, Stable supply of 9-12 Pa water pressure water temperature 90.5 C.
- Optimum water output design for extracting coffee essence:Ultra-high temperature protection, over-pressure protection, can be used for coffee embossing.
- 50mm professional flat knife grinding, inching switch to control the powder output.



Model	Voltage (V)	Power (κW)	Volume (L)	Net Weight (kg)	Dimensions (mm)
DZ-1	220	2.2	6.6	30	365X545X460
DZ-1G	220	2.2	6.6	35	365X545X570

Semi Automatic Coffee Maker

Features

- Heightened coffee machine takeaway tall cup, made of high-quality mirror stainless steel and sprayed on the surface.
- Built-in suction water circulation and water capacity measurement system, always keep the water pressure stable.
- Design of mother and son double boilers, stable outlet water and outlet gas.
- Automatic air supply system, equipped with buttons that can continuously discharge water.
- Optimum water output design for extracting coffee essence:Ultra-high temperature protection, over-pressure protection, can be used for coffee embossing.
- Safe electric heating constant temperature system; stable supply of 9 Pa water pressure, water temperature 90±5 C.
- Double head and double steam outlet, produced by single and double mouth.



Model	Voltage (V)	Power (κW)	Volume (L)	Net Weight (kg)	Dimensions (mm)
DZ-2	220	3.75	11	68	665x560x580
DZ-3	220	3.75	16	88	895x560x580

Coffee Machine

Fully Automatic Coffee Machine

Features

- Two boilers separately for steam making and coffee making
- Grind coffee bean instantly and completely automatically
- Brew aromatic coffee just by pushing a small button
- Easy to operate with LCD display guide
- Hot water and steam ready for use whenever necessary
- Cup pre-warming function
- Removable Water Tank and Drip Tray
- Italian 20 bar Invensys pump



Model	Voltage (V)	Power (κW)	Output (cup/h)	Hot water output (L/H)	Bean Box (g)	Net Weight (kg)	Dimensions (mm)
ME-709	220	1.25	90	1.8	250	15	438x452x465

Fully Automatic Espresso Cappuccino Coffee Machine

Features

- Two boilers separately for steam making and coffee making
- Grind coffee bean instantly and completely automatically
- Brew aromatic coffee just by pushing a small button
- Easy to operate with LCD display guide
- Hot water and steam ready for use whenever necessary
- Cup pre-warming function
- Removable Water Tank and Drip Tray
- Italian 20 bar Invensys pump



CE, EMC,ROHS & GS certificates are available.

Model	Voltage (V)	Power (κW)	Output (cup/h)	Hot water output (L/H)	Bean Box (g)	Net Weight (kg)	Dimensions (mm)
ME-715	220	1.25	90	2.0	300	11.6	438x280x368
ME-717	220	1.25	90	2.0	300	11	422x280x380

Coffee Warmer

Features

- Ideal for restaurants, cafes, or other heavy-duty applications
- Compact design is ideal for applications with limited counter space
- Stainless steel construction is durable and easy to maintain



Model	Voltage (V)	Power (κW)	Temperature (°C)	Net Weight (kg)	Dimensions (mm)
LR-W-1	220	0.1	0~100	1.6	247x233x68
LR-W-2	220	0.2	0~100	2.5	358x178x68

Distillation Coffee Machine

Features

- Ideal for restaurants, cafes, or other heavy-duty applications
- Compact design is ideal for applications with limited counter space
- Stainless steel construction is durable and easy to maintain



Model	Voltage (V)	Power (κW)	Net Weight (kg)	Dimensions (mm)
DW-17	220	0.15	6.5	205x385x450

Chocolate Dispenser & Chocolate Fountain

Chocolate Dispenser CE ETL RoHS

Features

- Good in quality and lovely design
- Bain-marie heating system with a wide controlled range if temperature 30 to 90
- Thermostat for adjusting temperature as required
- Special anti-clogging faucet
- #304 stainless steel boiler with thermal protector
- Drip tray with float indicator warning when full
- Food-grade high density polycarbonate bowl,remove and clean easily



Model	Voltage (V)	Hot Power (W)	Motor Power (W)	Temperature (°C)	Frequency (Hz)	Net Weight (kg)	Dimensions (mm)
CH-5	220-240/110-115	400	40	30~90	50-60	6	400x320x470
CH-10	220-240/110-115	400	40	30~90	50-60	7	400x320x470

Chocolate Dispenser CE ETL RoHS

Features

- Good in quality and lovely design
- Bain-marie heating system with a wide controlled range if temperature 30 to 90
- Thermostat for adjusting temperature as required
- Special anti-clogging faucet
- #304 stainless steel boiler with thermal protector
- Drip tray with float indicator warning when full
- Food-grade high density polycarbonate bowl,remove and clean easily



Model	Voltage (V)	Power (W)	Capacity (L)	Temperature (°C)	Net Weight (kg)	Dimensions (mm)
CH-5L	220	1000	5	85	6.8	410x280x465
CH-10L	220	1000	10	85	7.5	410x280x580

Chocolate Fountain

Features

- Lower noise with professional motor
- Temperature control switch adjustable
- Stainless steel bowl, tower and screw
- Large chocolate pot prevent splashing
- Melt chocolate automatically
- Rubber righ seal avoid any chocolate leak
- Easy to use and clean up
- Digital Switch



Model	Voltage (V)	Power (kW)	Capacity (kg/h)	Temperature (°C)	Net Weight (kg)	Dimensions (mm)
CH-4F	220	0.23	4	30~150	8	φ280x560
CH-5F	220	0.23	5	30~150	9	φ330x680

Commercial Blender

Commercial Blender

Features

- This high performance with drive coupling made entirely of metal to give your customers the smoothest, most delicious margaritas or daiquiris they've ever had!
- This blender features convenient measurement markings on the container so you can easily and accurately measure ingredients for the perfect mix.
- Pulse, the stainless steel blade design continuously forces your mixture into the blades, ensuring that there are never chunks of ice or other product leftover at the end of the blending process.



Model	Voltage(V)	Power(κW)	Capacity(L)	Speed(rpm)	Net Weight(kg)	Dimensions(mm)
BL-666D	220	1.5	4	12000-28000	6.5	222x222x500
BL-767	220	1.5	2	25000	4	315x260x375

Commercial Blender

Features

- The BL-666B blender is a professional blender built to last.
- The generous 2000ml hardened cup is designed to handle abrasions, acidity as well as high temperatures.
- SUS420. 6 leaves, 2mm thick blade easily cuts through ice frozen fruits and vegetables and even coffee beans and remains sharp for longer.
- The high-speed inlet bearing and motor is encased in waterproof housing, while the air flow is structured as to minimise noise during operation.
- A clear and bright LED display with triple function smart buttons makes for ease of use while the dual safety function protects the motor in the event of overheating.



Model	Voltage(V)	Power(κW)	Capacity(L)	Speed(rpm)	Net Weight(kg)	Dimensions(mm)
BL-666B	220	1.5	2	25000	6	210x210x540

Commercial Blender

Features

- The BL-666A blender is a professional blender built to last.
- The generous 1500ml hardened cup is designed to handle abrasions, acidity as well as high temperatures.
- SUS304. 6 leaves, 2mm thick blade easily cuts through ice frozen fruits and vegetables and even coffee beans and remains sharp for longer.
- The high-speed inlet bearing and motor is encased in waterproof housing, while the air flow is structured as to minimise noise during operation.
- A clear and bright LED display with triple function smart buttons makes for ease of use while the dual safety function protects the motor in the event of overheating.



Model	Voltage(V)	Power(κW)	Capacity(L)	Speed(rpm)	Net Weight(kg)	Dimensions(mm)
BL-666A	220	1.5	1.5	12000-28000	6	210x210x540

Commercial Blender

Features

- The blender enclosure significantly reduce noise
- Wave-Action system forces product into blade for smooth blending
- Stackable polycarbonate container



Model	Voltage(V)	Power(κW)	Capacity(L)	Speed(rpm)	Net Weight(kg)	Dimensions(mm)
BL-156	220	1.8	2	25000	9.23	300x295x565

Ice Crusher & Ice Shaver & Milk Shake

Ice Crusher

Features

- Serve delicious in a variety of tasty flavors
- High output to ensure you have a constant supply of ice during your busiest hours.
- Its 4 1/4" diameter hopper makes it easy to drop ice into the grinding mechanisms
- The hopper is made of stainless steel for long-lasting durability,
- Motor is designed to give you the power and reliability you need



SL-108 CE



Two Blade
ZY-114 CE

Model	Voltage (V)	Power (W)	Productivity (kg/h)	Net Weight (kg)	Dimensions (mm)
SL-108	220	300	65	5.5	400x160x250
ZY-114	220	200	80	7.5	405x245x425

Block Ice Shaver

Features

- The Block Ice Shaver is suitable for catering, restaurant,
- Protection Shield: prevents accidents from improper ice block installation
- New Handle Design: for softer and easier grip
- Designed for snow ice block, give you the best taste of snowflake ice
- Equipped with easy blade sharpening devices



A188 CE



A288 CE

Model	Voltage (V)	Power (W)	Productivity (kg/h)	Speedy (r/min)	Capacity (kg)	Platter Size (mm)	Net Weight (kg)	Dimensions (mm)
A188	220	250	60	1400	2	-	15	350x290x430
A288	220	250	90	1420	3	135	18	420x340x700

Milk Shake Machine

Features

- Powerful Motor
- Made of Stainless steel
- Lower noise
- Easy to control
- Durable and hygienic
- Simple structure, easy to operate, safe and reliable working
- Auto start with main switch, overload protection

Model	Voltage	Capacity	Net Weight	Dimensions
D-1L	220V	1L	3.5kg	190x160x530mm
D-2L	220V	2L	6.5kg	230x230x530mm



D-1L CE



D-2L CE

Juice Extractor & Lemon Juicer & Sugar Cane Juicer

Juice Extractor

Features

- Can be widely used to press apple, pineapple, grape, watermelon, ham melon, peeled orange and lemon, carrot, celery, cucumber, potato etc.
- Juicer and press residues can be automatically separated through centrifugalization.
- High efficiency, wide applications, easy operation



A4000 CE



B3000 CE



A3000 CE

Specifications

Model	Voltage (V)	Power (kW)	Speed (r/min)	Pomace Box Capacity(L)	Output (kg/h)	Net Weight (kg)	Dimensions (mm)
A4000	220	0.18	4300	2.5	50-65	7	358x220x300
B3000	220	0.37	2800	4	80-100	12	340x270x360
B2000	220	0.55	2800	4	100-120	19	430x350x450
A3000	220	0.37	2800	-	80-100	11	340x270x360
A2000	220	0.55	2800	-	100-120	19	430x350x450

Lemon Juicer

Features

- Multifunction lemon juicer small machine
- It is special for small lemon, kumquat machine.
- Widely used for orange, lemon, pomegranate, apple and so on.
- Function: Fast speed, household, small, high yield.
- Advantage, cheap price, widely use (commercial and household), Multifunction for different fruit



Specifications

Model	Voltage(V)	Power(kW)	Net Weight(kg)	Dimensions(mm)
1000C-1	220	0.1	23	325x325x490

Sugar Cane Juicer

Features

- Luxury all steel shape design, the machine is reasonable.
- High efficiency, low power consumption, low noise, small size, easy to operate and so on.
- All parts of the machine that touch the fresh cane are made from stainless steel, meeting health requirements.



SP-L100BE



SP-160B

Specifications

Model	Voltage (V)	Power (kW)	Capacity (L)	Output (kg/h)	Net Weight (kg)	Dimensions (mm)
SP-L100BE	220	0.75	1.5	350-400	76	500x470x685
SP-160B	220	0.75	1.5	300-350	53	435x480x880

Orange Juicer

Orange Juicer

Features

- 250W powerful motor with long life time
- 3 reamer sizes to accommodate different citrus fruits.(Only for model LR-MFC-50MC & LR-MFC-50MS)
- Removable plastic bowl for easy cleanup
- Non-skid feet ensure stability
- Heavy-duty construction with cast aluminum body
- Easy to use and clean



LR-MFC-50MH

LR-MFC-50MS

LR-MFC-50MC

Specifications

Model	Voltage (V)	Power (W)	Speed	Net Weight (kg)	Package Size (mm)
LR-MFC-50MH	220-240/110	250	1500RPM(50Hz) 1750RPM(60Hz)	8.65	375x24x460
LR-MFC-50MS	220-240/110	250	1500RPM(50Hz) 1750RPM(60Hz)	8.0	295x245x405
LR-MFC-50MC	220-240/110	250	1500RPM(50Hz) 1750RPM(60Hz)	8.15	295x245x530

Orange Juicer

Features

- High speed motor, low noise.
- A drip tight device, not the juice onto the motor.
- A permanent filter, specialty of squeezed orange
- With non-slip feet
- A professional commercial design squeezed orange juice, grapefruit juice.wheel.



CS-Z8

A9000 CE

Specifications

Model	Voltage (V)	Power (kW)	Frequency (Hz)	Speed (kg/h)	Net Weight (kg)	Dimensions (mm)
CS-Z8	220	0.18	50	2800	15.2	210x246x406
A9000	220	0.18	50	1600	2.5	300x190x340

Orange Juicer

Features

- Orange Juicer transparent plastic cover, food-grade plastic parts and remaining collector .
- The structure is well-organized and rational with anti-corrosion ,easy to wash.
- It could produce fresh and delicious juice in a few seconds after operation.
- The operation is simple and convenient .
- The juicer is easy to operate ,it can produces instantly .
- The juice is original and tasty ,green and trendy.



Model	Voltage(V)	Power(kW)	Orange size(mm)	Net Weight(kg)	Dimensions(mm)
2000M-6	220	0.085	40-90	4.5	295x245x460

Orange Juicer

Orange Juicer

Features

- Orange Juicer transparent plastic cover, food-grade plastic parts and remaining collector .
- The structure is well-organized and rational with anti-corrosion ,easy to wash.
- It could produce fresh and delicious juice in a few seconds after operation.
- The operation is simple and convenient .
- The juicer is easy to operate ,it can produces instantly .
- The juice is original and tasty ,green and trendy.



Model	Voltage (V)	Power (kW)	Orange Capacity	Orange size (mm)	Output (pcs/min)	Net Weight (kg)	Dimensions (mm)
2000M-2(P)-2	220	0.12	may add to top of container	60-90	18-25	41.5	500x490x905

Orange Juicer

Features

- Orange Juicer transparent plastic cover, food-grade plastic parts and remaining collector .
- The structure is well-organized and rational with anti-corrosion ,easy to wash.
- It could produce fresh and delicious juice in a few seconds after operation.
- The operation is simple and convenient .
- The juicer is easy to operate ,it can produces instantly .
- The juice is original and tasty ,green and trendy.



Model	Voltage	Power (kW)	Yield	Output (pcs/min)	Net Weight (kg)	Dimensions (mm)
2000A-1	110V 60HZ 220V 50HZ	0.37	60%-70%	40	110	660x64x1720

Orange Juicer

Features

- Orange Juicer transparent plastic cover, food-grade plastic parts and remaining collector .
- The structure is well-organized and rational with anti-corrosion ,easy to wash.
- It could produce fresh and delicious juice in a few seconds after operation.
- The operation is simple and convenient .
- The juicer is easy to operate ,it can produces instantly .
- The juice is original and tasty ,green and trendy.



2000E-2

2000E-3

Model	Voltage (V)	Power (kW)	Yield	Orange size (mm)	Output (pcs/min)	Net Weight (kg)	Dimensions (mm)
2000E-2	220	0.12	40%-50%	40-80	20	45	400x330x780
2000E-3	220	0.12	40%-50%	40-80	20	53	400x330x780

9L Bowl Refrigerated Beverage Dispenser

Features

- Reasonable configuration.
- Excellent performance.
- Easy control.
- The body are made of stainless steel, the bowl are made of PC.
- Use Copper pipe to keep more quick and durable for cooling.
- Refrigerant R134A



Model	Voltage (V)	Power (κW)	Heat Power (κW)	Capacity (L)	Temperature (°C)	Flow Pattern	Net Weight (kg)	Dimensions (mm)
MC9x1	220	0.18	-	9	7~12	Mixing	13	210x390x670
SC9x1	220	0.18	-	9	7~12	Spraying	13	210x390x670
MCH9x1	220	0.18	0.36	9	7~12 / 52~58	Mixing	14	210x390x670
SCH9x1	220	0.18	0.36	9	7~12 / 52~58	Spraying	14	210x390x670
MC9x2	220	0.28	-	9x2	7~12	Mixing	21	330x390x670
SC9x2	220	0.28	-	9x2	7~12	Spraying	23	330x390x670
MCH9x2	220	0.28	0.8	9x2	7~12 / 52~58	Mixing	24	330x390x670
SCH9x2	220	0.28	0.8	9x2	7~12 / 52~58	Spraying	26	330x390x670

9L Bowl Refrigerated Beverage Dispenser

Features

- Reasonable configuration.
- Excellent performance.
- Easy control.
- The body are made of stainless steel, the bowl are made of PC.
- Use Copper pipe to keep more quick and durable for cooling.
- Refrigerant R134A



Model	Voltage (V)	Power (κW)	Heat Power (κW)	Capacity (L)	Temperature (°C)	Flow Pattern	Net Weight (kg)	Dimensions (mm)
MC9x3	220	0.32	-	9x3	7~12	Mixing	27	410x390x670
SC9x3	220	0.32	-	9x3	7~12	Spraying	29	410x390x670
MCH9x3	220	0.32	1	9x3	7~12 / 52~58	Mixing	30	410x390x670
SCH9x3	220	0.32	1	9x3	7~12 / 52~58	Spraying	32	410x390x670
MC9x4	220	0.38	-	9x4	7~12	Mixing	30	540x390x670
SC9x4	220	0.38	-	9x4	7~12	Spraying	35	540x390x670
MCH9x4	220	0.38	1.2	9x4	7~12 / 52~58	Mixing	33	540x390x670
SCH9x4	220	0.38	1.2	9x4	7~12 / 52~58	Spraying	38	540x390x670

Single 18L Bowl Refrigerated Beverage Dispenser

Features

- Reasonable configuration.
- Excellent performance.
- Easy control.
- The body are made of stainless steel, the bowl are made of PC.
- Use Copper pipe to keep more quick and durable for cooling.



Model	Voltage (V)	Power (κW)	Capacity (L)	Refrigerant	Temperature (°C)	Flow Pattern	Net Weight (kg)	Dimensions (mm)
MC18Lx1	220	0.18	18	R134A	7~12	Mixing	24	430x350x740
SC18Lx1	220	0.18	18	R134A	7~12	Spraying	24	430x350x740

Double 18L Bowl Refrigerated Beverage Dispenser

Features

- Reasonable configuration.
- Excellent performance.
- Easy control.
- The body are made of stainless steel, the bowl are made of PC.
- Use Copper pipe to keep more quick and durable for cooling.



Model	Voltage (V)	Power (κW)	Capacity (L)	Refrigerant	Temperature (°C)	Flow Pattern	Net Weight (kg)	Dimensions (mm)
MC18Lx2	220	0.28	18x2	R134A	7~12	Mixing	32	480x460x740
SC18Lx2	220	0.28	18x2	R134A	7~12	Spraying	32	480x460x740

Triple 18L Bowl Refrigerated Beverage Dispenser

Features

- Reasonable configuration.
- Excellent performance.
- Easy control.
- The body are made of stainless steel, the bowl are made of PC.
- Use Copper pipe to keep more quick and durable for cooling.



Model	Voltage (V)	Power (κW)	Capacity (L)	Refrigerant	Temperature (°C)	Flow Pattern	Net Weight (kg)	Dimensions (mm)
MC18Lx3	220	0.38	18x3	R134A	7~12	Mixing	39	700x430x740
SC18Lx3	220	0.38	18x3	R134A	7~12	Spraying	39	700x430x740

Single 18L Bowl Refrigerated Beverage Dispenser

Features

- Reasonable configuration.
- Excellent performance.
- Easy control.
- The body are made of stainless steel, the bowl are made of PC.
- Use Copper pipe to keep more quick and durable for cooling.



Model	Voltage (V)	Power (κW)	Heat Power (κW)	Capacity (L)	Temperature (°C)	Flow Pattern	Net Weight (kg)	Dimensions (mm)
MCD18Lx1	220	0.18	0.6	18	7~12	Mixing	24	430x350x740
SCD18Lx1	220	0.18	0.6	18	7~12	Spraying	25	430x350x740
MCDH18Lx1	220	0.18	0.6	18	7~12 / 52~58	Mixing	25	430x350x740
SCDH18Lx1	220	0.18	0.6	18	7~12 / 52~58	Spraying	26	430x350x740

Double 18L Bowl Refrigerated Beverage Dispenser

Features

- Reasonable configuration.
- Excellent performance.
- Easy control.
- The body are made of stainless steel, the bowl are made of PC.
- Use Copper pipe to keep more quick and durable for cooling.



Model	Voltage (V)	Power (κW)	Heat Power (κW)	Capacity (L)	Temperature (°C)	Flow Pattern	Net Weight (kg)	Dimensions (mm)
MCD18Lx2	220	0.28	1.2	18x2	7~12	Mixing	29	480x430x740
SCD18Lx2	220	0.28	1.2	18x2	7~12	Spraying	31	480x430x740
MCDH18Lx2	220	0.28	1.2	18x2	7~12 / 52~58	Mixing	31	480x430x740
SCDH18Lx2	220	0.28	1.2	18x2	7~12 / 52~58	Spraying	34	480x430x740

Triple 18L Bowl Refrigerated Beverage Dispenser

Features

- Reasonable configuration.
- Excellent performance.
- Easy control.
- The body are made of stainless steel, the bowl are made of PC.
- Use Copper pipe to keep more quick and durable for cooling.
- Refrigerant R134A



Model	Voltage (V)	Power (κW)	Heat Power (κW)	Capacity (L)	Temperature (°C)	Flow Pattern	Net Weight (kg)	Dimensions (mm)
MCD18Lx3	220	0.38	1.5	18x3	7~12	Mixing	37	700x430x740
SCD18Lx3	220	0.38	1.5	18x3	7~12	Spraying	39	700x430x740
MCDH18Lx3	220	0.38	1.5	18x3	7~12 / 52~58	Mixing	41	700x430x740
SCDH18Lx3	220	0.38	1.5	18x3	7~12 / 52~58	Spraying	44	700x430x740

Single 50L Bowl Refrigerated Beverage Dispenser

Features

- Reasonable configuration.
- Excellent performance.
- Easy control.
- The body are made of stainless steel, the bowl are made of PC.
- Use Copper pipe to keep more quick and durable for cooling.
- Refrigerant R134A



Model	Voltage (V)	Power (κW)	Heat Power (κW)	Capacity (L)	Temperature (°C)	Flow Pattern	Net Weight (kg)	Dimensions (mm)
MC50L	220	0.38	-	50	7~12	Mixing	25	500x500x720
SC50L	220	0.38	-	50	7~12	Spraying	26	500x500x720
MCH50L	220	0.38	0.6	50	7~12 / 52~58	Mixing	26	500x500x720
SCH50L	220	0.38	0.6	50	7~12 / 52~58	Spraying	27	500x500x720

Single 25L Bowl Refrigerated Beverage Dispenser

Features

- Reasonable configuration.
- Excellent performance.
- Easy control.
- The body are made of stainless steel, the bowl are made of PC.
- Use Copper pipe to keep more quick and durable for cooling.
- Refrigerant R134A



Model	Voltage (V)	Power (κW)	Capacity (L)	Refrigerant	Temperature (°C)	Flow Pattern	Net Weight (kg)	Dimensions (mm)
MC25L	220	0.24	25	R134A	7~12	Mixing	19	380x420x740

Italy Soft Ice Cream Machine

Features

- It is a smart and multifunction machine can make soft ice cream, slush, juice and cocktails, etc.
- Each cylinder is controlled by an independent control system.
- Eight speeds and pulses for adjustment.
- Quiet heavy-duty motor.
- Makes delicious ice desserts
- Color available: Black, White, Red



Model	Voltage (V)	Power (κW)	Capacity (L)	Refrigerant	Temperature (°C)	Flow Pattern	Net Weight (kg)	Dimensions (mm)
DI-6L	220	0.6	6x1	404A	7~-7	Mixing	30	260x420x740
DI-6Lx2	220	0.9	6x2	404A	7~-7	Mixing	43	470x420x740

Commercial Slushy Machine

Commercial Slushy Machine (CE)

Features

- Eight speeds and pulses for adjustment.
- Quiet heavy-duty motor.
- Makes delicious ice desserts
- Color available:Black, White, Red



Model	Voltage (V)	Power (κW)	Capacity (L)	Refrigerant	Temperature (°C)	Flow Pattern	Net Weight (kg)	Dimensions (mm)
SM10Lx1N	220	0.3	10x1	R134A	-2 ~ -3	Mixing	28	270x580x790
SM10Lx2N	220	0.4	10x2	R134A	-2 ~ -3	Mixing	44	470x580x790
SM10Lx3N	220	0.5	10x3	R134A	-2 ~ -3	Mixing	61	660x580x790

Commercial Slushy Machine (CE)

Features

- Eight speeds and pulses for adjustment.
- Quiet heavy-duty motor.
- Makes delicious ice desserts
- Color available:Black, White, Red



Model	Voltage (V)	Power (κW)	Capacity (L)	Refrigerant	Temperature (°C)	Flow Pattern	Net Weight (kg)	Dimensions (mm)
SM12Lx1	220	0.4	12x1	R134A	-2~-3	Mixing	28	270x580x790
SM12Lx2	220	0.5	12x2	R134A	-2~-3	Mixing	44	470x580x790
SM12Lx3	220	0.6	12x3	R134A	-2~-3	Mixing	63	660x580x790

Commercial Slushy Machine (CE)

Features

- Eight speeds and pulses for adjustment.
- Quiet heavy-duty motor.
- Makes delicious ice desserts
- Color available:Black, White, Red
Cycle: 30~45 mins



Model	Voltage (V)	Power (κW)	Capacity (L)	Refrigerant	Temperature (°C)	Flow Pattern	Net Weight (kg)	Dimensions (mm)
SM15Lx1	220	0.3	15x1	R134A	-2 ~ -3	Mixing	29	290x560x760
SM15Lx2	220	0.4	15x2	R134A	-2 ~ -3	Mixing	41	420x560x760
SM15Lx3	220	0.5	15x3	R134A	-2 ~ -3	Mixing	58	600x560x760

Snow Machine & Flake Ice Maker

High-Speed Snow Machine

Features

- Digital panel, rapid ice making
- Multi-gear speed regulation, threaded roller
- Water shortage protection, low noise operation
- One-button cleaning function 1-60 levels can be adjusted, convenient and fast.
- The extended threaded ice-making roller produces ice in 3 seconds and has a high output, which improves the efficiency faster than smooth rollers
- The food-grade transparent material box is not easy to produce bacteria



Model	Voltage (V)	Power (κW)	Cooling	Output	Refrigerant	Net Weight (kg)	Dimensions (mm)
FL-150F	220	1.3	Air cooling	200KG/24H	R404A	46	394x595x730
FL-150AF	220	1.3	Air cooling	200KG/24H	R22	40	394x595x730
FL-300F	220	1.9	Air cooling	350KG/24H	R404A	52	455x595x730
FL-300AF	220	1.9	Air cooling	300KG/24H	R22	52	455x595x730

Flake Ice Maker

Features

- One-button refrigeration is convenient and fast, and the ice can be produced quickly and the ice production capacity is large
- High-speed fan exhaust heat, thickened integrated large-capacity ice storage bucket
- Water shortage alarm, low noise operation
- The ice bucket adopts PE built-in blue light sterilization, thickened foam insulation layer, good cooling effect, durable, anti-collision and anti-deformation
- The machine intelligently controls the water intake without supervision, making everything simple and convenient



Model	Voltage (V)	Power (κW)	Cooling	Ice storage capacity (L)	Net weight (Kg)	Refrigerant	Output	Dimensions (mm)
PBJ-200	220	1.65	Air cooling	420	105	R22	200kg/24h	775X820X1740
PBJ-300	220	2.3	Air cooling	420	165	R22	300kg/24h	775X820X1740
PBJ-500	220	2.3	Air cooling	420	165	R22	500kg/24h	775X820X1840

Bullet Ice Maker



Bullet Ice Maker

Features

- Self-diagnosis function
- Adjustable feet
- Micro-coupter electronic control technique
- Portable appearance
- Powerful performance
- Hosting events such as BBQs, picnics, birthday parties.



Model	Voltage (V)	Ice Making Capacity (kg/24h)	Ice Storage (kg/pound)	Cooling Type	Net Weight (kg/pound)	Dimensions (mm)
ZB-14	220~240	10	0.8/1.7	Air Cooling	13.5/29.8	305x380x380

Bullet Ice Maker

Features

- Self-diagnosis function
- Adjustable feet
- Micro-coupter electronic control technique
- Portable appearance
- Powerful performance
- Hosting events such as BBQs, picnics, birthday parties.



Model	Voltage (V)	Ice Making Capacity (kg/24h)	Ice Storage (kg/pound)	Cooling Type	Net Weight (kg/pound)	Dimensions (mm)
ZB-15	220~240	15	1.4/3	Air Cooling	17/37.5	360x398x414

Self Contained Solid Ice Maker



Self Contained Solid Ice Maker

Product Description

- The Accepted standard of ice all international markets.because of its wide heat exchange surface with inner hole-allowing quicker cooling.
- These units have an integrated storage bin for compact space utilization.
- Reliable operation and easy installation.
- Maximum performance, Heavy duty machine.
- Stainless Steel Construction, Hygienic and clean.
- Self-contained unit, Easy to access ice, Removable legs.



Specifications

Model	Power (kW)	Voltage (V)	Max daily production -24h (kg)	Storage Capacity (kg)	legs (mm)	Refrigerant (mm)	Net Weight (kg)	Dimensions (mm)
IC-25	0.53	220	20~30	10	60	R134A	32	500x500x750
IC-45	0.4	220	48~50	20	60	R134A	36	500x560x750
IC-60	0.48	220	60~70	35	60	R134A	46	706x560x950
IC-90	0.68	220	90~100	45	60	R134A	52	830x570x950
IC-120	0.75	220	120~130	45	60	R134A	54	830x570x950

Self Contained Solid Ice Maker

Product Description

- The Accepted standard of ice all international markets.because of its wide heat exchange surface with inner hole-allowing quicker cooling.
- These units have an integrated storage bin for compact space utilization.
- Reliable operation and easy installation.
- Maximum performance, Heavy duty machine.
- Stainless Steel Construction, Hygienic and clean.
- Self-contained unit, Easy to access ice, Removable legs.



Specifications

Model	Power (kW)	Voltage (V)	Max daily production -24h (kg)	Storage Capacity (kg)	legs (mm)	Refrigerant (mm)	Net Weight (kg)	Dimensions (mm)
IC-20A	0.32	220	20	10	60	R134A	36	403x535x773
IC-40A	0.42	220	40	20	60	R134A	40	496x535x773
IC-60A	0.65	220	60	35	60	R134A	62	696x612x1024
IC-90A	0.75	220	90	45	60	R22/R134A	80	816x612x1024
IC-120A	0.85	220	120	45	60	R22/R134A	80	816x612x1024

Self Contained Solid Ice Cube



Ice Cube(2x2x2cm) AIR COOLED

Product Description

- The Accepted standard of ice all international markets.because of its wide heat exchange surface with inner hole-allowing quicker cooling.
- These units have an integrated storage bin for compact space utilization.
- Reliable operation and easy installation.
- Maximum performance.
- Heavy duty machine.
- Stainless Steel Construction.
- Hygienic and clean.
- Self-contained unit.
- Easy to access ice.
- Removable legs.



Specifications

Model	Power (kW)	Voltage (V)	Max daily production -24h (kg)	Storage Capacity (kg)	legs (mm)	Refrigerant (mm)	Net Weight (kg)	Dimensions (mm)
IC-150	0.75	220	150~160	150	100	R134A	64	760x820x1330
IC-250	1.08	220	250~270	150	100	R404A	68	760x820x1360
IC-350	1.3	220	350~370	150	100	R404A	72	780x820x1550
IC-500	1.5	220	500~550	250	100	R404A	74	760x820x1680

Ice Cream Machine

- All stainless steel body ,durable
- LCD operator Panel
- The first circle producing time is around 10-15 mins
- The blender with food-grade materials ,safety and health
- Automatic cleaning, simple and easy to use
- The well -know brand compressor ,refrigeration fast, high capacity , low noise, energy saving
- Optional : Precooling the mix and keeping fresh



Countertop Ice Cream Machine

Model	LR-IC-8T
Power (kW)	1.7
Voltage (V)	220
Production Capacity (L/h)	17-28
Cups per Hour (80g/cup)	200-300 Cups
Hopper Capacity (L)	2x5.8
Net Weight (kg)	116
Dimensions (mm)	518x745x770



- All stainless steel body ,durable
- LCD operator Panel
- The first circle producing time is around 10-15 mins
- The blender with food-grade materials ,safety and health
- Automatic cleaning, simple and easy to use
- The well -know brand compressor ,refrigeration fast, high capacity , low noise, energy saving
- Optional : Precooling the mix and keeping fresh



Countertop Ice Cream Machine

Model	LR-IC-11T
Power (kW)	1.5
Voltage (V)	220
Production Capacity (L/h)	14-20
Cups per Hour (80g/cup)	330-420 Cups
Hopper Capacity (L)	1x12
Net Weight (kg)	100
Dimensions (mm)	473x830x790

Ice Cream Machine

Model	LR-IC-2	LR-IC-3
Power (kW)	1.7	2.6
Voltage (V)	220	220
Production Capacity (L/h)	17-28	28-36
Cups per Hour (80g/cup)	200-300 Cups	330-420 Cups
Hopper Capacity (L)	2x5.8	2x5.8
Net Weight (kg)	143	158
Dimensions (mm)	518x745x1425	518x745x1425



- All stainless steel body ,durable
- LCD operator Panel
- The first circle producing time is around 10-15 mins
- The blender with food-grade materials ,safety and health
- Automatic cleaning, simple and easy to use

- The well -know brand compressor ,refrigeration fast, high capacity , low noise, energy saving
- Optional : Precooling the mix and keeping fresh



Countertop Ice Cream Machine

Model	LR-IC20A
Power (kW)	1.9
Voltage (V)	220
Production Capacity (L/h)	20
Refrigerant	R22/R41a
Hopper Capacity (L)	-
Net Weight (kg)	88
Dimensions (mm)	544x710x850

- All stainless steel body ,durable
- LCD operator Panel
- The first circle producing time is around 10-15 mins
- The blender with food-grade materials ,safety and health
- Automatic cleaning, simple and easy to use

- The well -know brand compressor ,refrigeration fast, high capacity , low noise, energy saving
- Optional : Precooling the mix and keeping fresh



Ice Cream Machine

Model	LR-IC-20
Power (kW)	1.9
Voltage (V)	220
Production Capacity (L/h)	20
Refrigerant	R22/R41a
Hopper Capacity (L)	-
Net Weight (kg)	98
Dimensions (mm)	504x705x1177

- Pure 304 food grade stainless steel large evaporating cylinder with a capacity of 13L to ensure large output.
- The pure 304 food-grade stirring shaft is matched with high-strength food-grade curved scraper, and the raw materials are stirred more delicately.
- The unique transparent push-pull discharge valve design has better refrigeration sealing and practicability.
- The whole machine is equipped with a high-strength motor, which is efficient, balanced and silent.
- All-copper tube large condenser is equipped with high-power motor fan and world-renowned brand compressor Embraco/Panasonic/copeland/tecumseh, which greatly shortens the cooling time and improves the cooling efficiency.
- Microcomputer LCD screen, built-in one-key refrigeration, one-key cleaning, current protection, voltage alarm, cooling time adjustment and other functions.

Countertop Hard Ice Cream Machine

Model	LR-GT30	LR-GT50
Power (kW)	2.4	3.3
Voltage (V)	220	220
Production Capacity (L/h)	38-40	48-50
Cylinder Capacity (L)	13	16
Refrigerant Gas	R22/R404A/R410A	R22/R404A/R410A
Compressor	Panasonic/Embracl	Panasonic/Embracl/Tecumseh
Net Weight (kg)	130	150
Dimensions (mm)	780x560x730	780x560x730



Hard Ice Cream Machine

Model	LR-G30	LR-G50
Power (kW)	2.4	3.3
Voltage (V)	220	220
Production Capacity (L/h)	38-40	48-50
Cylinder Capacity (L)	13	16
Refrigerant Gas	R22/R404A/R410A	R22/R404A/R410A
Compressor	Panasonic/Embracl	Panasonic/Embracl/Tecumseh
Net Weight (kg)	140	160
Dimensions (mm)	820x555x1355	820x555x1355



- Precooling the mix and keeping fresh
- Higher Overrun
- Cabinet
- Lower noise
- Optional: 220V/60Hz/1Ph



6218 (Capacity varies depending on condition of mix and environment.)
Single Flavor, Table Model Gravity Freezer



Beater
Stainless Steel, More Overrun

Dispenser Door
With Muddler To Mix Well

Dimension	440x700x721mm 17.3"x24.6"x28.4"
Packing Size	500x770x890mm 19.7"x30.3"x35"
Voltage	220V,50Hz,1Ph
Power	1.80kW
Net Weight	101kg
Gross Weight	113kg
Capacity	130 Cones/Hour(100g/Cone),18 Liters/Hour
Cylinder	1.70 Liters
Hopper	8.00 Liters
Beater Motor	One,1.25HP
Main Compressor	One,3150 BTU,R404a
Separate Hopper Refrigeration(S.H.R)	One compressor,480BTU/HR,R134a

6248 **6348**

Twin Twist Flavors, Floor model, Gravity Freezer
Separate Control of Each Flavor

6248A **6348A**

Twin Twist Flavors, Floor model, Air Pump
Separate Control of Each Flavor



6248/6348



Beater
Stainless Steel, More Overrun



Stand pipe in hopper

6248A/6348A



Dispenser Door
With Muddler To Mix Well



Blade Scraper Beater
Stainless Steel, more Overrun



Pump in the hopper

Agitator
Optional

6228
Single Flavor, Table model, Gravity Freezer

- Precooling the mix and keeping fresh.
- Lower noise.
- Optional: 220V/60Hz/1 Ph
- 220V/60Hz/3 Ph

6228A
Single Flavor, Table model,Air pump

6228



Blade
Stainless Steel, more Overrun

6228A



Blade
Stainless Steel, more Overrun



	6228	6228A
Dimension	453x573x822mm	453x573x822mm
Packing Size	510x740x955mm	510x740x955mm
Voltage	220V,50Hz,1Ph	220V,50Hz,1Ph
Power	3kW	3kW
Net Weight	103kg	120kg
Gross Weight	115kg	135kg
Capacity	30 Liters/Hour	30 Liters/Hour
Cylinder	1.70 Liters	1.70 Liters
Hopper	12.00 Liters	10.00 Liters
Beater Motor	One,1.25HP	One,1.25HP
Main Compressor	One,3650 BTU,R404a	One,3650 BTU,R404a
Separate Hopper Refrigeration(S.H.R)	One compressor, 480BTU/HR,R134a	One compressor, 480BTU/HR,R134a

	6248	6348	6248A	6348A
Dimension	553x654x1474mm	553x654x1374mm	553x654x1474mm	553x654x1374mm
Packing Size	650x780x1620mm	650x780x1520mm	650x780x1620mm	650x780x1520mm
Voltage	220V,50Hz,1Ph	380V,50Hz,3Ph	220V,50Hz,1Ph	380V,50Hz,3Ph
Power	4kW	4.4kW	4kW	4.4kW
Net Weight	200kg	204kg	211kg	215kg
Gross Weight	217kg	219kg	228kg	230kg
Capacity	390 Cone/Hour(100g/Cone),50Liters/Hour	420 Cone/Hour(100g/Cone),55Liters/Hour	65Liters/Hour	420 Cone/Hour(100g/Cone),55Liters/Hour
Cylinder	1.70 Litersx2	1.70 Litersx2	1.70 Litersx2	1.70 Litersx2
Hopper	12.00 Litersx2	12.00 Litersx2	10.00 Litersx2	10.00 Litersx2
Beater Motor	Two,1.25HPx2	Two,1.0HPx2	Two,1.25HPx2	Two,1.0HPx2
Main Compressor	Two,3150 BTUx2,R404a	Two,3650 BTUx2,R404a	Two,3150 BTUx2,R404a	Two,3650 BTUx2,R404a
Separate Hopper Refrigeration(S.H.R)	One compressor, 480BTU/HR,R134a	One compressor, 480BTU/HR,R134a	One compressor, 480BTU/HR,R134a	One compressor, 480BTU/HR,R134a



Sushi Showcase

Features

- Stainless steel base.
- Evaporator with hydrophilic aluminum coil, corrosion resistant.
- High quality international brand compressor: Konor compressor.
- CFC free refrigerant R134a.
- Static cooling system.
- Operating temperature: 2°C~8°C, under room temperature of 28°C



Specifications

Model	Power (kW)	Voltage (V)	Volume (L)	Temperature (°C)	Net Weight (kg)	Dimensions (mm)
G120LA	0.23	220	50	2~8	33	1220x350x306
G150LA	0.25	220	68	2~8	38	1520x350x306
G180LA	0.35	220	85	2~8	43	1820x350x306

Countertop Cake Showcase

Features

- Fully enclosed, low noise,high efficiency.
- Cools fast, with a strong corrosion resistance, energy saving, serpentine pipes increase the cooling area, durable.
- Can be used for a long time, and improve the life.refrigeration more quickly.
- Evaporation heat increase refrigeration,pipeline life long, strong corrosion resistance.
- Temperature control precision, convenient operation.
- Electronic thermostat and digital display for accuracy and easy reading.
- Internal Lights:LED; R134A Refrigerant



Specifications

Model	Power (kW)	Voltage (V)	Capacity-Gross (L)	Temperature (°C)	Number Of Shelves	Defrost System	Net Weight (kg)	Dimensions (mm)
CD-60K2	0.38	220	60	2~8	1	Forced Air Circulation	85	610x485x680
CD-80K2	0.56	220	80	2~8	1	Forced Air Circulation	90	905x485x680

Countertop Cake Showcase

Features

- Fully enclosed, low noise,high efficiency.
- Cools fast, with a strong corrosion resistance, energy saving, serpentine pipes increase the cooling area, durable.
- Evaporation heat increase refrigeration,pipeline life long, strong corrosion resistance.
- Temperature control precision, convenient operation.
- Electronic thermostat and digital display for accuracy and easy reading.
- Internal Lights:LED; R134A Refrigerant



CD-75H2



CD-120E3

Specifications

Model	Power (kW)	Voltage (V)	Capacity-Gross (L)	Temperature (°C)	Number Of Shelves	Defrost System	Net Weight (kg)	Dimensions (mm)
CD-75H2	0.35	220	110	2~8	1	Forced Air Circulation	65	750x460x660
CD-90H2	0.4	220	160	2~8	1	Forced Air Circulation	80	900x460x660
CD-120H2	0.45	220	200	2~8	1	Forced Air Circulation	90	1200x460x660
CD-120E3	0.7	220	420	2~8	2	Forced Air Circulation	210	1200x700x1200
CD-150E3	0.8	220	520	2~8	2	Forced Air Circulation	235	1500x700x1200
CD-180E3	0.85	220	620	2~8	2	Forced Air Circulation	260	1800x700x1200
CD-200E3	0.9	220	700	2~8	2	Forced Air Circulation	290	2000x700x1200

Cake Showcase

Features

- Fully enclosed, low noise,high efficiency.
- Cools fast, with strong corrosion resistance, energy saving, serpentine pipes increase the cooling area, durable.
- Can be used for a long time, and improve the life.refrigeration more quickly.
- Evaporation heat increase refrigeration, pipeline life long, strong corrosion resistance.
- Temperature control precision, convenient operation.
- Electronic thermostat and digital display for accuracy and easy reading.



CD-150Q3



CD-150P3S

Specifications

Model	Power (kW)	Voltage (V)	Capacity (L)	Refrigerant	Temperature (°C)	Net Weight (kg)	Dimensions (mm)
CD-120Q3	0.75	220	380	R134A	2~8	180	1200x750x1300
CD-150Q3	0.85	220	560	R134A	2~8	210	1500x750x1300
CD-180Q3	0.95	220	740	R134A	2~8	240	1800x750x1300
CD-200Q3	1.05	220	920	R134A	2~8	270	2000x750x1300
CD-120P3S	0.845	220	310	R134A	2~8	245	1200x730x1200
CD-150P3S	0.945	220	405	R134A	2~8	305	1500x730x1200
CD-180P3S	1.045	220	500	R134A	2~8	390	1800x730x1200



Cake Showcase



Cake Showcase

Features

- Fully enclosed, low noise, high efficiency.
- Cools fast, with strong corrosion resistance, energy saving, serpentine pipes increase the cooling area, durable.
- Can be used for a long time, and improve the life. refrigeration more quickly.
- Evaporation heat increase refrigeration, pipeline life long, strong corrosion resistance.
- Temperature control precision, convenient operation.
- Electronic thermostat and digital display for accuracy and easy reading.



Specifications

Model	Power (kW)	Voltage (V)	Capacity (L)	Refrigerant	Temperature (°C)	Net Weight (kg)	Dimensions (mm)
CD-120D3	0.7	220	318	R134A	2~8	220	1200x730x1200
CD-150D3	0.8	220	418	R134A	2~8	255	1500x730x1200
CD-180D3	0.85	220	518	R134A	2~8	280	1800x730x1200
CD-200D3	0.9	220	600	R134A	2~8	310	2000x730x1200

Cake Showcase

Features

- Fully enclosed, low noise, high efficiency.
- Cools fast, with a strong corrosion resistance, energy saving, serpentine pipes increase the cooling area, durable.
- Evaporation heat increase refrigeration, pipeline life long, strong corrosion resistance.
- Temperature control precision, convenient operation.
- Electronic thermostat and digital display for accuracy and easy reading.
- Internal Lights: LED; R134A Refrigerant



Specifications

Model	Power (kW)	Voltage (V)	Capacity-Gross (L)	Temperature (°C)	Number Of Shelves	Defrost System	Net Weight (kg)	Dimensions (mm)
CD-120S4	0.998	220	370	2~8	3	Forced Air Circulation	270	1200x815x1400
CD-150S4	1.0	220	505	2~8	3	Forced Air Circulation	300	1500x815x1400
CD-180S4	1.2	220	625	2~8	3	Forced Air Circulation	334	1800x815x1400
CD-200S4	1.43	220	700	2~8	3	Forced Air Circulation	440	2000x815x1400

Square Series Cake Showcase



Square Series Cake Showcase

Features

- All cold vertical cabinets have heated front and top glass and hot air blown onto side glass to prevent condensation.
- Double glazed side panels and doors.
- Ambient temperature: 32°C at 82% R.H.
- Fluorescent lighting.
- Removable filter on condenser for easy cleaning.
- Electronic temperature control and display.
- Ventilated cooling system.
- Automatic defrost.
- Adjustable shelves.
- Internal Lights: LED
- R134A Refrigerant



Specifications

Model	Power (kW)	Voltage (V)	Capacity-Gross (L)	Temperature (°C)	Number Of Shelves	Defrost System	Net Weight (kg)	Dimensions (mm)
CD-120I5	0.63	220	700	2~8	4	Forced Air Circulation	260	1200x730x1800
CD-150I5	0.65	220	850	2~8	4	Forced Air Circulation	320	1500x730x1800
CD-180I5	0.78	220	1000	2~8	4	Forced Air Circulation	360	1800x730x1800



COMMERCIAL REFRIGERATION LINKRICH

Glass Door Chiller and Freezer

- 50mm insulation for increased energy efficiency.
- Forced air cooling ensures consistent internal temperatures.
- Adjustable shelving with anti-tilt protection.
- Self-closing doors and lockable front castors.
- Advanced electronic control provides temperature display, ease of set point control, condenser blockage alarm.
- All units include castor/rollers (may not be included in picture)

Combination Cake Display Features

- Adjustable shelves.
- High-density foam, closed glass structure, good insulation, energy-saving.
- Air cooling, air-cooled circulation, cooling speed, temperature is even.
- Each shelf with lights, enhancing display effect.
- Hollow insulated safety glass, the glass door with heater defrosting, reducing consumption.
- Refrigerating or heating or ambient temperature.
- Stainless steel, marble or artificial stone (the color can be selected according to the customer request).
- Refrigerant : R134a.



Part NO	Name	Dimensions LxWxH (mm)	Temperature Range(°C)	Material
1 / 3	Luxurious Cake showcasw (CD-B3)	1200x730x1200	2~8	Marble or artificial
		1500x730x1200		
		1800x730x1200		
		2000x730x1200		
2	Ark of corner	730x730x800		
4	The casher	1200x730x800	---	
		1500x730x800		
5	Vertical Cake showcase (CD-I5)	1200x730x1800	2~8	
		1500x730x1800		
		1800x730x1800		



Corner Display



SBZJ02
Material: Marble
Dimensions: 730x730x510mm

SS-SBZJ02
Material: Stainless Steel
Dimensions: 660x660x510mm

SBZJ01
Material: Marble
Dimensions: 840x840x510mm

SS-SBZJ01
Material: Stainless Steel
Dimensions: 804x804x510mm

Cashier Counter



SBZT02
Material: Marble
Dimensions: 600x840x790mm

SS-SBZT02
Material: Stainless Steel
Dimensions: 600x804x790mm

SBZT03
Material: Marble
Dimensions: 1200x730x790mm

SS-SBZT03
Material: Stainless Steel
Dimensions: 1200x660x790mm



One Big Door
SG-360A1



One Big Door
SG-360FA1



One Big Door
SD-360FA1

	SG-360A1	SG-360FA1	SD-360FA1
Capacity-Gross(Liter)	326	300	265
External Dimension(mm)	600x670x2100	600x700x2100	640x730x2180
Net Weight(kg)	98	108	120
Temperature Range(°C)	2~8	2~8	-22~-18
Refrigeration Power(W)	210	240	1150
Door Material	Alluminium alloy	Alluminium alloy	PVC
Door Lock	Yes	Yes	Yes
Temperature Controller	Digital	Digital	Digital
Number Of Shelves	5	5	5
Refrigerant	R134A	R134A	R404A
Cooling System	Direct Cooling	Fan Cooling	Fan Cooling
Ambient Operating Temperature(°C)	32	32	32

- 50mm insulation for increased energy efficiency.
- Forced air cooling ensures consistent internal temperatures.
- Adjustable sheving with anti-tilt protection.
- Self-closing doors and lockable front castors.
- Advanced electronic control provides temperature display,ease of set point control,condenser blockage alam.
- All units includecastor/rollers (may not be included in picture)



Two Big Door
SG-860A2

Two Big Door
SG-860FA2

Two Big Door
SD-860FA2

(Sliding Door)
Two Big Door
SG-860FB2

	SG-860A2	SG-860FA2	SD-860FA2	SG-860FB2
Capacity-Gross(Liter)	707	647	656	585
External Dimension(mm)	1200x670x2100	1200x700x2100	1240x730x2180	1220x720x2100
Net Weight(kg)	148	168	190	158
Temperature Range(°C)	2~8	2~8	-22~-18	2~8
Refrigeration Power(W)	340	380	1294	380
Door Material	Alluminium alloy	Alluminium alloy	PVC	PVC
Door Lock	Yes	Yes	Yes	Yes
Temperature Controller	Digital	Digital	Digital	Digital
Number Of Shelves	5+5	5+5	5+5	5+5
Refrigerant	R134A	R134A	R404A	R134A
Cooling System	Direct Cooling	Fan Cooling	Fan Cooling	Fan Cooling
Ambient Operating Temperature(°C)	32	32	32	32

- 50mm insulation for increased energy efficiency.
- Forced air cooling ensures consistent internal temperatures.
- Adjustable sheving with anti-tilt protection.
- Self-closing doors and lockable front castors.
- Advanced electronic control provides temperature display,ease of set point control,condenser blockage alam.
- All units includecastor/rollers (may not be included in picture)



Three Big Door
SD-1260FA3

Three Big Door
SG-1260A3

Three Big Door
SG-1260FA3

	SD-1260FA3	SG-1260A3	SG-1260FA3
Capacity-Gross(Liter)	892	1089	1000
External Dimension(mm)	1840x730x2180	1800x670x2100	1800x700x2100
Net Weight(kg)	210	198	228
Temperature Range(°C)	-22~-18	2~8	2~8
Refrigeration Power(W)	1960	460	530
Door Material	PVC	Alluminium alloy	Alluminium alloy
Door Lock	No	No	No
Temperature Controller	Digital	Digital	Digital
Number Of Shelbes	5+5+5	5+5+5	5+5+5
Refrigerant	R404A	R134A	R134A
Cooling System	Fan Cooling	Direct Cooling	Fan Cooling
Ambient Operating Temperature(°C)	32	32	32

Glass Door Drink Display

- 50mm insulation for increased energy efficiency.
- Forced air cooling ensures consistent internal temperatures.
- Adjustable shelving with anti-tilt protection.
- Self-closing doors and lockable front castors.
- Advanced electronic control provides temperature display, ease of set point control, condenser blockage alarm.
- All units include castor/rollers (may not be included in picture)
- Customized light box stickers



One Big Door
LG-268E Direct Cooling
LG-368E Direct Cooling

One Big Door
LG-268WE Fan Cooling
LG-368WE Fan Cooling



	LG-268E	LG-368E	LG-268WE	LG-368WE
Capacity-Gross(Liter)	268	368	268	368
External Dimension(mm)	575x535x1930	622x585x2080	575x535x1930	622x585x2080
Internal Dimension(mm)	481x408x1141	528x458x1291	481x408x1141	528x458x1291
Temperature Range(°C)	0~10	0~10	0~10	0~10
Refrigeration Power(W)	250	280	250	280
Door Material	Plastic	Plastic	Aluminum alloy	Aluminum alloy
Door Lock	No	No	No	No
Temperature Controller	Mechanical	Mechanical	Digital	Digital
Number Of Shelbes	4	4	4	4
Refrigerant	R134A	R134A	R134A	R134A
Cooling System	Direct	Direct	Fan Cooling	Fan Cooling
Operating Temperature(°C)	32	32	32	32
Net Weight(kg)	60	70	60	70

Glass Door Drink Display

- 50mm insulation for increased energy efficiency.
- Forced air cooling ensures consistent internal temperatures.
- Adjustable shelving with anti-tilt protection.
- Self-closing doors and lockable front castors.
- Advanced electronic control provides temperature display, ease of set point control, condenser blockage alarm.
- All units include castor/rollers (may not be included in picture)
- Customized light box stickers



Two Big Door
LG-788M2W Fan Cooling
LG-1260M2W Fan Cooling

Three Big Door
LG-1860M3F Fan Cooling

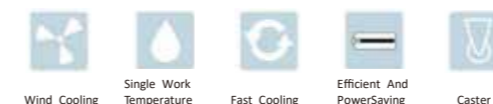

	LG-788M2WE	LG-1260M2WE	LG-1860M3WE
Capacity-Gross(Liter)	788	1260	1860
External Dimension(mm)	1100x620x2030	1260x720x2100	1860x720x2100
Internal Dimension(mm)	1010x485x1500	1190x585x1590	1770x585x1590
Temperature Range(°C)	0~10	0~10	0~10
Refrigeration Power(W)	400	580	700
Door Material	Aluminum alloy	Aluminum alloy	Aluminum alloy
Door Lock	No	No	No
Temperature Controller	Digital	Digital	Digital
Number Of Shelbes	10	10	10
Refrigerant	R134A	R134A	R134A
Cooling System	Fan Cooling	Fan Cooling	Fan Cooling
Operating Temperature(°C)	32	32	32
Net Weight(kg)	90	120	180

Solid Door Working Chillers

CFC free refrigerant and foam.
Stainless steel framework construction.
Electronic thermostat and LED digital display for accuracy and easy reading.
Automatic defrosting, automatic evaporation of defrost water.
Bottom with round edges for easy sanitation.
Temperature:2~8°C.



260 Liter ,2-solid Doors
Stainless steel Table

400 Liter ,3-solid Doors
Stainless steel Table

260 Liter ,2-solid Doors
Stainless steel Table



D-2AH CE

D-3AH CE

D-2A CE

400 Liter ,3-solid Doors
Stainless steel Table

540 Liter ,4-solid Doors
Stainless steel Table



D-3A CE

D-4A CE

Model	Capacity -Gross (Liter)	External Dimension (mm)	Inner dimension (mm)	Temperature Range (°C)	Refrigeration Power (kW)	Number Of Shelves	Cooling System	Refrigerator	Ambient Operating Temperature(°C)	Net Weight (kg)
D-2A	260	1360X700X850	794X560X580	+2~+8	0.4	4xGN1/1	Fan Cooling	R134A	32	98
D-3A	400	1795x700x850	1230x560x580	+2~+8	0.4	6xGN1/1	Fan Cooling	R134A	32	115
D-4A	540	2230x700x850	1669x560x580	+2~+8	0.4	8xGN1/1	Fan Cooling	R134A	32	141
D-2AH	260	1360x700x1050	794x560x580	+2~+8	0.4	4xGN1/1	Fan Cooling	R134A	32	106
D-3AH	400	1795x700x1050	1230x560x580	+2~+8	0.4	6xGN1/1	Fan Cooling	R134A	32	120

Solid Door Working Chillers

CFC free refrigerant and foam.
Stainless steel framework construction.
Electronic thermostat and LED digital display.
Automatic defrosting, automatic evaporation of defrost water.
Bottom with round edges for easy sanitation.
Temperature Range:2~8 ° C.

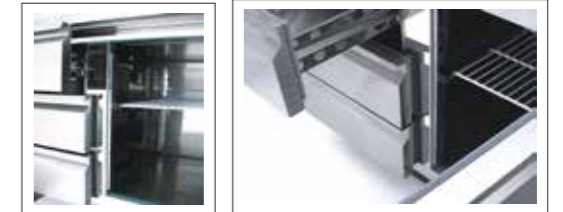

260 Liter ,1-solid Doors with 2 Drawers
Stainless steel Table

400 Liter ,1-solid Doors with 4 Drawers
Stainless steel Table



D-1A2

D-1A4

400 Liter , 6 Drawers
Stainless steel Table

400 Liter ,2-solid Doors with 3 Drawers
Stainless steel Table



D-A6

D-2A3

Model	Capacity -Gross (Liter)	External Dimension (mm)	Inner dimension (mm)	Temperature Range (°C)	Refrigeration Power (kW)	Number Of Shelves	Cooling System	Refrigerator	Ambient Operating Temperature(°C)	Net Weight (kg)
D-1A2	260	1360X700X850	794X560X580	+2~+8	0.4	2xGN1/1	Fan Cooling	R134A	32	105
D-1A4	400	1795x700x850	1230x560x580	+2~+8	0.4	2xGN1/1	Fan Cooling	R134A	32	140
D-A6	400	1795x700x850	1230x560x580	+2~+8	0.4	-	Fan Cooling	R134A	32	145
D-2A3	400	1795x700x850	1230x560x580	+2~+8	0.4	4xGN1/1	Fan Cooling	R134A	32	127

Solid Door Working Chillers

CFC free refrigerant and foam.
Stainless steel construction.
Electronic thermostat and digital display for accuracy and easy reading.
Automatic defrosting, automatic evaporation of defrost water.
Bottom with round edges for easy sanitation.

225 Liter ,2-solid Doors
Stainless steel Table



G-2A

230 Liter ,2-solid Doors
Stainless steel Table



G-2AN
CE

225 Liter ,1-solid Doors with 2 Drawers
Stainless steel Table



G-1A2

225 Liter , 4 Drawers
Stainless steel Table



G-A4

Model	Capacity -Gross (Liter)	External Dimension (mm)	Inner dimension (mm)	Temperature Range (°C)	Refrigeration Power (kW)	Number Of Shelves	Cooling System	Refrigerator	Ambient Operating Temperature(°C)	Net Weight (kg)
G-2A	225	900x700x850	830x595x510	+4~+8	0.2	4xGN1/1	Direct Cooling	R134A	32	80
G-2AN	230	900x700x(850+130)	830x595x510	+4~+8	0.2	4xGN1/1	Direct Cooling	R134A	32	80
G-1A2	225	900x700x850	830x595x510	+4~+8	0.2	2xGN1/1	Direct Cooling	R134A	32	90.5
G-A4	225	900x700x850	830x595x510	+4~+8	0.2	-	Direct Cooling	R134A	32	100

Solid Door Vegetable Working Chillers

CFC free refrigerant and foam.
Stainless steel construction.
Electronic thermostat and digital display for accuracy and easy reading.
Automatic defrosting, automatic evaporation of defrost water.
Bottom with round edges for easy sanitation.

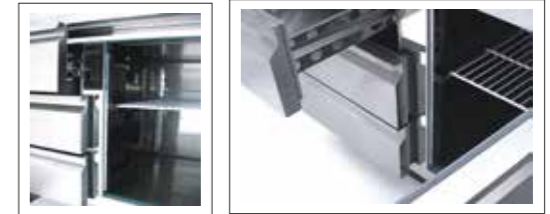

225 Liter, 2-solid Doors
Marble with Bain Marie Table



G-2AH

225 Liter, 2-solid Doors
Bain Marie Table with Glass



G-2AP CE

350 Liter, 3-solid Doors
Bain Marie Table with Glass



G-3AP

350 Liter ,3-solid Doors
Plastic cutting board with Bain Marie Table



G-3AG CE

350 Liter ,3-solid Doors
Stainless steel Table



G-3A CE

Model	Capacity -Gross (Liter)	External Dimension (mm)	Inner dimension (mm)	Temperature Range (°C)	Refrigeration Power (kW)	Number Of Shelves	Number Of Shelves (Bain Marie)	Cooling System	Refrigerator	Ambient Operating Temperature (°C)	Net Weight (kg)
G-2AH	225	900x700x(850+230)	830x595x510	+2~+8	0.2	4xGN1/1	5xGN1/6	Direct Cooling	R134A	32	89
G-2AP	225	900x700x(850+400)	830x585x510	+2~+8	0.2	4xGN1/1	2xGN1/1 +2xGN1/4	Direct Cooling	R134A	32	100
G-3AP	350	1365x700x(850+400)	1295x580x510	+2~+8	0.38	6xGN1/1	4xGN1/1	Direct Cooling	R134A	32	110
G-3AG	350	1365x700x850	1295x585x510	+4~+8	0.38	6xGN1/1	4xGN1/1	Direct Cooling	R134A	32	91
G-3A	350	1365x700x850	1295x585x510	+4~+8	0.38	6xGN1/1	-	Direct Cooling	R134A	32	92

Solid Door Pizza Working Chillers

CFC free refrigerant and foam.
 Stainless steel framework construction.
 Electronic thermostat and LED digital display for accuracy and easy reading.
 Automatic defrosting, automatic evaporation of defrost water.
 Bottom with round edges for easy sanitation.
 Temperature: 2~8 °C.

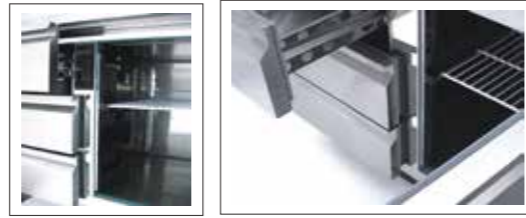

Model	Capacity -Gross (Liter)	External Dimension (mm)	Inner dimension (mm)	Temperature Range (°C)	Refrigeration Power (kW)	Number Of Shelves	Cooling System	Refrigerator	Ambient Operating Temperature(°C)	Net Weight (kg)
E-2A	360	1510x800x(850+160)	940x680x560	+2~+8	0.4	4xGN1/1	Fan Cooling	R134A	32	203
E-3A	350	1365x700x(850+160)	1290x580x450	+4~+8	0.38	6xGN1/1	Direct Cooling	R134A	32	160
E-2A2	350	1365x700x830	1290x580x450	+4~+8	0.38	4xGN1/1	Direct Cooling	R134A	32	160
E-3AL	550	2025x800x(850+160)	1450x680x560	+2~+8	0.4	6xGN1/1	Fan Cooling	R134A	32	300
E-2AS	360+51	1510x800x(850+595)	940x680x560	+2~+8	0.4+0.2	4xGN1/1	Fan Cooling	R134A	32	255
E-3AS	379	1365x700x(850+595)	1290x580x450	+4~+8	0.38+0.2	6xGN1/1	Direct Cooling	R134A	32	210
E-2A7S	460+74	2025x800x(850+595)	940x680x560	+2~+8	0.4+0.2	4xGN1/1	Fan Cooling	R134A	32	365

Solid Door Chillers

CFC free refrigerant and foam.
 Stainless steel framework construction.
 Electronic thermostat and LED digital display for accuracy and easy reading.

Automatic defrosting, automatic evaporation of defrost water.
 Bottom with round edges for easy sanitation.
 Temperature: 0~10 °C
 *B: with Splashback



	TB-520A2	TB-520B2	TB-520A3	TB-520B3
Capacity-Gross(Liter)	325	325	520	520
Inner dimension(mm)	970x570x510	970x570x510	1560x660x510	1560x660x510
External Dimension(mm)	1500x760x800	1500x760x(800+150)	2100x800x800	2100x800x(800+150)
Temperature Range(°C)	0~10	0~10	0~10	0~10
Refrigeration Power(W)	420	420	530	530
Internal Material	Stainless Steel	Stainless Steel	Stainless Steel	Stainless Steel
External Material	Stainless Steel	Stainless Steel	Stainless Steel	Stainless Steel
Number Of Shelves	2	2	3	3
Shelves Size(mm)	550x480	550x480	515x640	515x640
Cooling System	Fan Cooling	Fan Cooling	Fan Cooling	Fan Cooling
Refrigerator	R134A	R134A	R134A	R134A
Ambient Operating Temperature(°C)	32	32	32	32
Net Weight(kg)	120	120	130	130

GASTRONORM CHILLER AND FREEZERS

50mm insulation for increased energy efficiency.
 Forced air cooling ensures consistent internal temperatures.
 Adjustable shelving with anti-tilt protection.
 Advanced electronic control provides temperature display, ease of set point control, condenser blockage alarm.
 Optional castor/Rollers

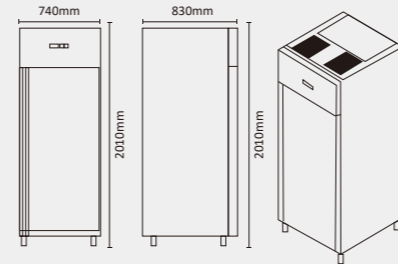

Refrigeration Type
Fan Cooling ❄️

GN650S1 / GN650S2
GN650S1B / GN650S2B

Model	Capacity -Gross (Liter)	Inner dimension (mm)	External Dimension (mm)	Temperature Range (°C)	Refrigeration Power (W)	Door Number	Temperature Controller	Number Of Shelves	Refrigerator	Ambient Operating Temperature(°C)	Net Weight (kg)
GN650S1	550	690x600x1390	740x830x2010	+2~+8	400	1	Digital	3	R134A	32	117
GN650S2	550	690x600x1390	740x830x2010	+2~+8	400	2	Digital	3	R134A	32	119
GN650S1B	550	690x600x1390	740x830x2010	-22~-18	700	1	Digital	3	R404A	32	124
GN650S2B	550	690x600x1390	740x830x2010	-22~-18	700	2	Digital	3	R404A	32	126

GASTRONORM CHILLER AND FREEZERS

50mm insulation for increased energy efficiency.
 Forced air cooling ensures consistent internal temperatures.
 Adjustable shelving with anti-tilt protection.
 Advanced electronic control provides temperature display, ease of set point control, condenser blockage alarm.
 Optional castor/Rollers

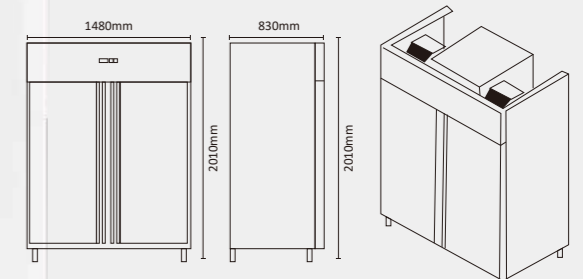

Refrigeration Type
Fan Cooling ❄️

GN1410S2 / GN1410S4
GN1410S2B / GN1410S4B

Model	Capacity -Gross (Liter)	Inner dimension (mm)	External Dimension (mm)	Temperature Range (°C)	Refrigeration Power (W)	Door Number	Temperature Controller	Number Of Shelves	Refrigerator	Ambient Operating Temperature(°C)	Net Weight (kg)
GN1410S2	1250	1340x690x1390	1480x830x2010	+2~+8	650	2	Digital	3+3	R134A	32	184
GN1410S4	1250	1340x690x1390	1480x830x2010	+2~+8	650	4	Digital	3+3	R134A	32	188
GN1410S2B	1250	1340x690x1390	1480x830x2010	-22~-18	1000	2	Digital	3+3	R404A	32	190
GN1410S4B	1250	1340x690x1390	1480x830x2010	-22~-18	1000	4	Digital	3+3	R404A	32	194

SOLID DOOR CHILLER AND FREEZERS

50mm insulation for increased energy efficiency.
Forced air cooling ensures consistent internal temperatures.
Adjustable shelving with anti-tilt protection.
Advanced electronic control provides temperature display, ease of set point control, condenser blockage alarm.
All units include castor/rollers
(may not be included in picture)



Model	Capacity -Gross (Liter)	Inner dimension (mm)	External Dimension (mm)	Temperature Range (°C)	Refrigeration Power (W)	Door Number	Temperature Controller	Number Of Shelves	Refrigerator	Ambient Operating Temperature(°C)	Net Weight (kg)
D-670FA1	670	690x600x1390	740x830x2010	-18~-15	510	1	Digital	3	R404A	36	98
D-670FA2	670	690x600x1390	740x830x2010	-18~-15	510	2	Digital	3	R404A	36	98
G-670FA1	670	690x600x1390	740x830x2010	0~10	400	1	Digital	3	R404A	36	98
G-670FA2	670	690x600x1390	740x830x2010	0~10	400	2	Digital	3	R404A	36	98

SOLID DOOR CHILLER AND FREEZERS

50mm insulation for increased energy efficiency.
Forced air cooling ensures consistent internal temperatures.
Adjustable shelving with anti-tilt protection.
Advanced electronic control provides temperature display, ease of set point control, condenser blockage alarm.
All units include castor/rollers
(may not be included in picture)



Model	Capacity -Gross (Liter)	Inner dimension (mm)	External Dimension (mm)	Temperature Range (°C)	Refrigeration Power (kW)	Door Number	Temperature Controller	Number Of Shelves	Refrigerator	Ambient Operating Temperature(°C)	Net Weight (kg)
D-1460FA2	1460	1340x690x1390	1480x830x2010	-18~-15	0.79	2	Digital	3+3	R404A	36	184
D-1460FA4	1460	1340x690x1390	1480x830x2010	-18~-15	0.79	4	Digital	3+3	R404A	36	184
G-1460FA2	1460	1340x690x1390	1480x830x2010	-0~10	0.79	2	Digital	3+3	R404A	36	184
G-1460FA4	1460	1340x690x1390	1480x830x2010	0~10	0.79	4	Digital	3+3	R404A	36	184
DG-1460A2	1460	1340x690x1390	1480x830x2010	-18~-15/0~10	0.69	2	Digital	3+3	R404A	36	184
DG-1460A4	1460	1340x690x1390	1480x830x2010	-18~-15/0~10	0.69	4	Digital	3+3	R404A	36	184

SOLID DOOR CHILLER AND FREEZERS

50mm insulation for increased energy efficiency.
Forced air cooling ensures consistent internal temperatures.
Adjustable shelving with anti-tilt protection.
Advanced electronic control provides temperature display, ease of set point control, condenser blockage alarm.
All units include castor/rollers
(may not be included in picture)

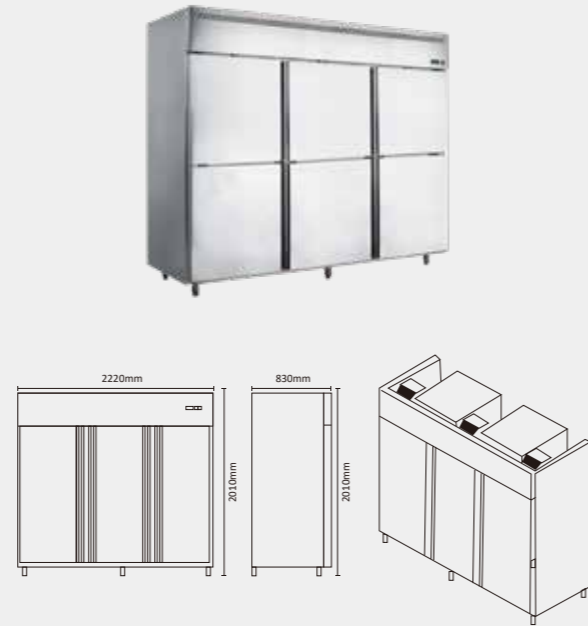

Refrigeration Type
Fan Cooling

D-1780FA3 / D-1780FA6
G-1780FA3 / G-1780FA6

Direct Cooling

DG-1780A3 / DG-1780A6

Model	Capacity -Gross (Liter)	Inner dimension (mm)	External Dimension (mm)	Temperature Range (°C)	Refrigeration Power (kW)	Door Number	Temperature Controller	Number Of Shelves	Refrigerator	Ambient Operating Temperature(°C)	Net Weight (kg)
D-1780FA3	1770	2010x600x1390	2220x830x2010	-18~-15	1.3	3	Digital	3+3+3	R404A	36	235
D-1780FA6	1770	2010x600x1390	2220x830x2010	-18~-15	1.3	6	Digital	3+3+3	R404A	36	235
G-1780FA3	1770	2010x600x1390	2220x830x2010	0~10	1.3	3	Digital	3+3+3	R404A	36	235
G-1780FA6	1770	2010x600x1390	2220x830x2010	0~10	1.3	6	Digital	3+3+3	R404A	36	235
DG-1780A3	1780	2010x600x1390	2220x830x2010	-18~-15/0~10	1.4	3	Digital	3+3+3	R404A	36	235
DG-1780A6	1780	2010x600x1390	2220x830x2010	-18~-15/0~10	1.4	6	Digital	3+3+3	R404A	36	235

Glass Door Chillers

50mm insulation for increased energy efficiency.
Forced air cooling ensures consistent internal temperatures.
Adjustable shelving with anti-tilt protection.
Advanced electronic control provides temperature display, ease of set point control, condenser blockage alarm.
Optional castor/Rollers

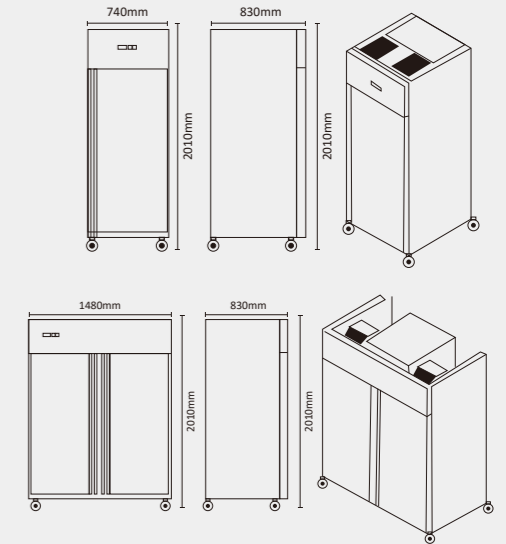

Refrigeration Type
Fan Cooling

GN650B1 / GN1410B

Model	Capacity -Gross (Liter)	Inner dimension (mm)	External Dimension (mm)	Temperature Range (°C)	Refrigeration Power (W)	Door Number	Temperature Controller	Number Of Shelves	Refrigerator	Ambient Operating Temperature(°C)	Net Weight (kg)
GN650B1	550	690x600x1390	740x830x2010	+2~+8	400	1	Digital	3	R134A	32	117
GN1410B2	1250	1340x690x1390	1480x830x2010	+2~+8	650	1	Digital	3+3	R134A	32	184

Blast Freezer



The blast chiller cool foods quickly and safety,designed to prevent surface freezing and preserve the nutritional value of your goods,this unit features exclusive food identification controller technology that automatically adjusts blast chilling cycles thanks to a single multi-sensor probe. One piece construction with rounded internal corners and s stainless steel interior and exterior ensure lasting durability while also keeping the unit easy to clean.The ideal holding temperature for your foods in ensured by thick interior wall and CFC-free polyurethane foamed-in place insulation.

- Prevents surface freezing and preserves nutritional values of food
- Stainless steel interior and exterior
- CFC-free polyurethane foamed-in-place unsulation
- Includes 3 removable sire rack with vertical spacing intervas.
- Capacity:3 pieces of oven trayss 600X400x50mm
- Fan cooling
- 1.5P comprossor and R404A Refrigerator

	LD-3	LD-5	LD-10	LD-14
Capacity-Gross(Liter)	91	127	230	318
Power (kW)	1.0	1.48	3.0	4.0
Voltage (V)	220	220	220	380
External Dimension(mm)	800x850x950	800x850x1050	800x850x1580	800x850x2000
Temperature range(°C)	-36~-40	-36~-40	-36~-40	-36~-40
Internal Material	Stainless Steel	Stainless Steel	Stainless Steel	Stainless Steel
External Material	Stainless Steel	Stainless Steel	Stainless Steel	Stainless Steel
Number of shelves	3x600x400x50	5x600x400x50	10x600x400x50	14x600x400x50
Cooling system	Fan Cooling	Fan Cooling	Fan Cooling	Fan Cooling
Refrigerator	R404A	R404A	R404A	R404A
Ambient operating temerature(°C)	32	32	32	32

Chest Freezers

Features

The Flat Top,Flat glass Chest Freezer offer the perfect display or storage for keeping meat&vegetables fresh f or a long time,9 sizes available

- Adoption of environment-friendly pollution-free freezing agent and vesicant.
- Fast cooling,low noise,low power consumption,stable performance.
- Balance gemel door,easy to open and close in the temperature between 35° and 70°.
- Ultra-thick foam door to avoid the loss of cooling air,perfect heat preservation.
- Compressor and the case are separate.Multi-side ventilation,perfect heat radiation effect
- Easy clean condenser design for better protection,less condensation,less humidity even in tropical climatic conditions
- Sliding glass lid(open left and right)
- Defrost water drain
- Lockable castor for easy positioning.



BD-258
BD-338



BD-1800

Convertical Cooling and Freezing Series of Single Temperature and Converting Door

Model	Power (W)	Voltage (V)	Capacity (L)	Temperature (°C)	Net Weight (kg)	Dimensions (mm)
BD-258	250	220	258	-18 or 0~10	40	1080x665x940
BD-338	280	220	338	-18 or 0~10	47	1300x665x940

Convertical Cooling and Freezing Series of Single Temperature and Covering Door

Model	Power (W)	Voltage (V)	Capacity (L)	Temperature (°C)	Net Weight (kg)	Dimensions (mm)
BD-1800	700	220	1800	-18 or 0~10	175	3305x930x1065
BD-1000	462	220	1000	-18 or 0~10	125	2305x930x945
BD-1200	518	220	1200	-18 or 0~10	135	2575x930x945
BD-1580T	700	220	1580	-18 or 0~10	165	2575x1050x1035

Chest Freezers

Features

The Flat Top, Flat glass Chest Freezer offer the perfect display or storage for keeping meat & vegetables fresh for a long time, 4 sizes available

- Adoption of environment-friendly pollution-free freezing agent and vesicant.
- Fast cooling, low noise, low power consumption, stable performance.
- Balance gemel door, easy to open and close.
- Ultra-thick foam door to avoid the loss of cooling air, perfect heat preservation.
- Compressor and the case are separate. Multi-side ventilation, perfect heat radiation effect
- Easy clean condenser design for better protection, less condensation, less humidity even in tropical climatic conditions
- Sliding glass lid (open left and right)
- Defrost water drain
- Lockable castor for easy positioning.



	WD4-580	WD4-750	WD4-860	WD4-970
Capacity-Gross(Liter)	580	750	860	970
External Dimension(mm)	1730x890x910	2180x890x910	2480x890x910	2780x890x910
Temperature Range(°C)	-18~0	-18~0	-18~0	-18~0
Refrigeration Power(W)	326	398	460	518
Net Weight(kg)	100	130	150	175
Lid	2 Sliding	2 Sliding	2 Sliding	2 Sliding
Lid Material	Glass	Glass	Glass	Glass
Color	White	White	White	White
Refrigerant	R134A	R134A	R134A	R134A
Cooling System	Direct Cooling	Direct Cooling	Direct Cooling	Direct Cooling
Ambient Operating Temperature(°C)	32	32	32	32

Supermarket Showcase

Features:

- Fan-assisted refrigeration display and storage
- Superior performance and European styling
- Easy clean and food safe environment
- Advanced ventilated cooling system
- Heavy duty castors
- Fast cooling
- Low noise
- Low power consumption
- Stable performance
- Color: silver panels
- Customize for style, dimensions, color, etc

Idear for:

- Cafes
- Juicer Bars
- Restaurants
- Hotel and Resorts
- Supermarket

WXG Supermarket Showcase
(Fresh Meat-case)



WXG Customer made

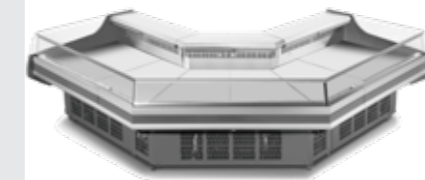

WSG Supermarket Showcase
(Dishes Showcase)



	WXG-200F	WXG-250F	WSG-200FK	WSG-250FK
Capacity-Gross(Liter)	160	201	151	192
External Dimension(mm)	2000x1180x900	2500x1180x900	2000x1180x1280	2500x1180x1280
Temperature Range(°C)	-2~8	-2~8	2~8	2~8
Refrigeration Power(W)	780	980	780	780
Light Power(W)			42	42
Light	LED	LED	LED	LED
Lid	No	No	2 Sliding	2 Sliding
Lid Material	No	No	Glass	Glass
Refrigerant	R404A	R404A	R404A	R404A
Cooling System	Fan Cooling	Fan Cooling	Fan Cooling	Fan Cooling
Ambient Operating Temperature(°C)	32	32	32	32
Net Weight(kg)	158	198	203	250

Supermarket Showcase

Compared with the traditional open island
Unique split the fence and the base can transform different effect.
Advanced ventilated cooling system
Heavy duty castors
Fast cooling,
Low noise,Low power consumption
Stable performance,
Color:silver panels
Customize for style, dimensions, color,etc

Idear for:
Cafes
Juicer Bars
Restaurants
Hotel and Resorts
Supermarket



LRG Supermarket Showcase



LRP Supermarket Showcase



LRF2 Supermarket Showcase



LRHD Supermarket Showcase

Specifications

Model	Capacity-Gross(Liter)	Display Area (m ²)	External Dimension(mm)	Temperature Range(°C)	Refrigeration Power(W)	Light Power(W)	Net Weight (kg)	Refrigerant	Cooling System	Ambient Operating Temperature(°C)
LRG-1200F	441	1.55	1200x800x1950	2~8	1370	LED126	223	R404A	Fan cooling	32
LRG-1500F	561	1.79	1500x800x1950	2~8	1756	LED168	260	R404A	Fan cooling	32
LRF2-20	1970	5.55	2100x950x1980	2~10	2105	LED210	310	R22/R404A	Fan cooling	32
LRF2-25	2488	7.08	2600x950x1980	2~10	2588	LED250	360	R22/R404A	Fan cooling	32
LRF2-30	3007	8.62	3100x950x1980	2~10	3155	LED310	405	R22/R404A	Fan cooling	32
LRP-2000F	568	1.81	2000x980x1680	2~8	1700	LED112	300	R404A	Fan cooling	32
LRP-2500F	716	2.24	2500x980x1680	2~8	2245	LED168	370	R404A	Fan cooling	32
LRHD-20	700	4.8	2000x1500x1600	2~8	2750	LED396	500	R22/R404A	Fan cooling	32

Supermarket Showcase

Features:
Compared with the traditional open island
Unique split the fence and the base can transform different effect.
Advanced ventilated cooling system
Heavy duty castors
Fast cooling,
Low noise, low power consumption
Stable performance,
Customize for style, dimensions, color,etc

Idear for:
Cafes
Juicer Bars
Restaurants
Hotel and Resorts
Supermarket



**D14-06Y
D14-08Y
D14-10Y**



**H19-04Y
H19-06Y
H19-08Y
H19-10Y**

	D14-06Y	D14-08Y	D14-10Y	H19-04Y	H19-06Y	H19-08Y	H19-10Y
Capacity-Gross(Liter)	410	520	630	1372	1862	2352	2842
Internal Dimension(mm)	1900x800x270	2400x800x270	2900x800x270	1500x1000x2100	2000x1000x2100	2500x1000x2100	3000x1000x2100
External Dimension(mm)	2000x1080x900	2500x1080x900	3000x1080x900	--	--	--	--
Temperature Range(°C)	-18~-22	-18~-22	-18~-22	2~8	2~8	2~8	2~8
Refrigeration Power(W)	--	--	--	--	--	--	--
Voltage(V)	380	380	380	380	380	380	380
Net Weight(kg)	250	300	350	400	532	665	798
Refrigerant	R404A	R404A	R404A	R404A	R404A	R404A	R404A
Cooling System	Fan cooling	Fan cooling	Fan cooling	Fan cooling	Fan cooling	Fan cooling	Fan cooling
Ambient Operating Temperature(°C)	32	32	32	32	32	32	32

Modular Cool room



High Quality

Each polyurethane prefab panel undergoes strict quality testing to ensure you receive a product that performs to your expectations. Our panelized designs are built in a factory and arrive at the construction site ready for quick assembly. As a result, labor costs and construction schedules are greatly reduced. These efficiencies translate into big savings.

Low Cost

Our panelized designs are built in a factory and arrive at the construction site ready for quick assembly. As a result, labor costs and construction schedules are greatly reduced. These efficiencies translate into big savings.

Quick Assembly

Each Panel is produced in factory-controlled conditions, and then shipped complete to the construction site for final assembly. Nearly all of our structures can be built in a fraction of the time that is required by conventional framing

1.Panels Dimension

Widths & Heights of Standard Panel

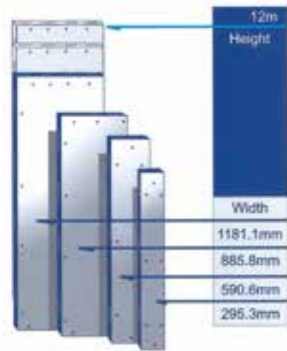

Polyurethane sandwiched panels are of 100% Polyurethane insulation, which is constructed by being foamed in place with retarded polyurethane using high pressure. They have certain dimension. Standard widths of panels are a multiple of 295.3mm. The maximum lengths of panels are 12m. Non-standard sizes are also available upon request with prices varying

2.Choice Embossed Aluminium

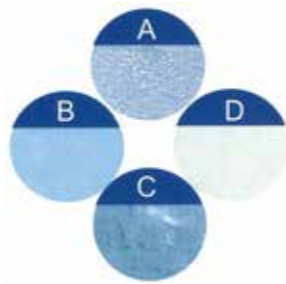

- A.Stucco Embossed Aluminium
- B.Stainless Steel
- C.Painted Galvanized Mild Steel
- D.PVC Steel
- E.Standard floor panels:1.2mm galvanized mild steel

3.Panels Thickness

Panel THK Operating Temp

50	5°C(or above)
75	-5°C(or above)
100	-25°C(or above)

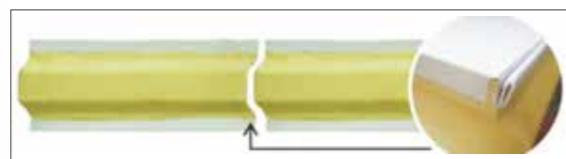

Gasket



The Solution to Cold-room Door



Cam lock



Gasket



- Double Handle Convex Hinged Door
- Standard Convex Hinged Door
- Standard Hinged Door
- Standard Straight Hinge Convex Door

Every panel consists of tongue and groove construction and can be tightened by a number of excentric fasters, which may be unscrewed easily with a hexagonal key.

Polyurethane Specification

According to the inspection result of national JB/T6527-92<modular cold room insulation sandwiched panel's technology conditions>

no	Inspection item	Unit	Technology inspection	Inspection result
1	Density	Kg/m ³	32~50	43
2	Compressing strength(10% deformation)	Kpa	≥160	200
3	Bending strength	Kpa	≥245	331
4	Absorbing rate	%	≤4	3
5	Heating coefficient	W/m.k	0.024	0.024
6	Average burning time(vertical)	S	≤30	3
7	average burning height(vertical)	S	≤250	250



Cold storage circular corner processing



Linkrich panels are appropriate for GB8624-1997<<Classification of the firing capability of construction-materials>>and reach the requirements of level B1 hard firing materials

Unit: mm

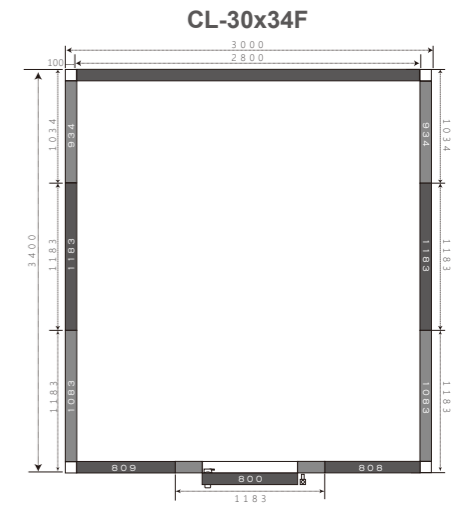
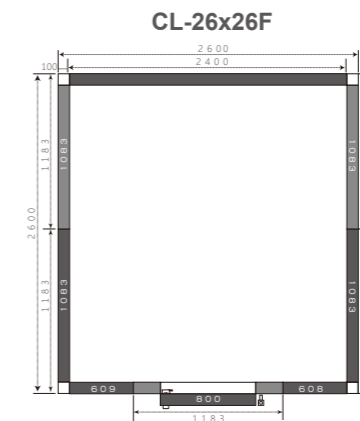
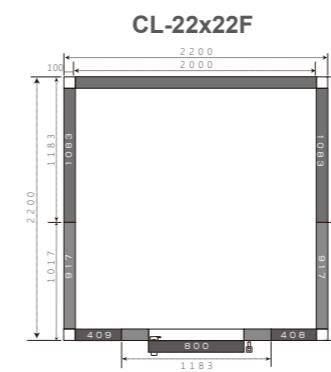

FREEZER ROOMS

	CL-22x22F	CL-26x26F	CL-30x34F
External Dimensions (mm)	2200x2200	2600x2600	3000x3400
Volume (m3)	8.8	12.67	19.71
Internal height (mm)	2200	2200	2200
External Height (mm)	2400	2400	2400
Panel Thickness (mm)	100	100	100
Door Opening	1900x800	1900x800	1900x800

- ▶ Heavy duty customized work table suitable for a variety of kitchen types.
- ▶ Adjustable feet to suit unflat floor. 1mm thickness stainless steel table top has curved edges for safety.
- ▶ A smooth work surface is ideal for preparing and processing sauces, meats and vegetable, and is large enough to complete most arts and crafts projects.

- ▶ Adjustable stainless steel shelf fits under the table and provides additional storage space for supplies.
- ▶ Optional splashback are hygienic and professional, practical, reliable and great value.
- ▶ Suitable for work, kitchen, restaurants and food preparation.

Assembling 2 Deck Working Table

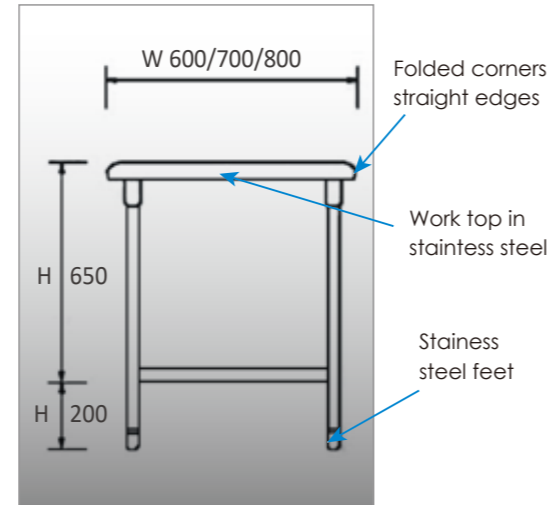

Central table+Splashback

600 Series Work Tables			
	Central table	Central table+Splashback	Optional
L x W x H mm	Model	Model	
900 x 600 x 850	BV600-90	BV600-90B	Wheels, Stainless Steel Drawer Assembly
1200 x 600 x 850	BV600-120	BV600-120B	Wheels, Stainless Steel Drawer Assembly
1500 x 600 x 850	BV600-150	BV600-150B	Wheels, Stainless Steel Drawer Assembly
1800 x 600 x 850	BV600-180	BV600-180B	Wheels, Stainless Steel Drawer Assembly
2100 x 600 x 850	BV600-210	BV600-210B	Wheels, Stainless Steel Drawer Assembly

700 Series Work Tables			
	Central table	Central table+Splashback	Optional
L x W x H mm	Model	Model	
900 x 700 x 850	BV700-90	BV700-90B	Wheels, Stainless Steel Drawer Assembly
1200 x 700 x 850	BV700-120	BV700-120B	Wheels, Stainless Steel Drawer Assembly
1500 x 700 x 850	BV700-150	BV700-150B	Wheels, Stainless Steel Drawer Assembly
1800 x 700 x 850	BV700-180	BV700-180B	Wheels, Stainless Steel Drawer Assembly
2100 x 700 x 850	BV700-210	BV700-210B	Wheels, Stainless Steel Drawer Assembly

800 Series Work Tables			
	Central table	Central table+Splashback	Optional
L x W x H mm	Model	Model	
900 x 800 x 850	BV800-90	BV800-90B	Wheels, Stainless Steel Drawer Assembly
1200 x 800 x 850	BV800-120	BV800-120B	Wheels, Stainless Steel Drawer Assembly
1500 x 800 x 850	BV800-150	BV800-150B	Wheels, Stainless Steel Drawer Assembly
1800 x 800 x 850	BV800-180	BV800-180B	Wheels, Stainless Steel Drawer Assembly
2100 x 800 x 850	BV800-210	BV800-210B	Wheels, Stainless Steel Drawer Assembly

- ▶ Heavy duty customized work table suitable for a variety of kitchen types.
- ▶ Adjustable feet to suit unflat floor. 1mm thickness stainless steel table top has curved edges for safety.
- ▶ A smooth work surface is ideal for preparing and processing sauces, meats and vegetable, and is large enough to complete most arts and crafts projects.

- ▶ Adjustable stainless steel shelf fits under the table and provides additional storage space for supplies.
- ▶ Optional splashback are hygienic and professional, practical, reliable and great value.
- ▶ Suitable for work, kitchen, restaurants and food preparation.

Assembling 2 Deck Working Table

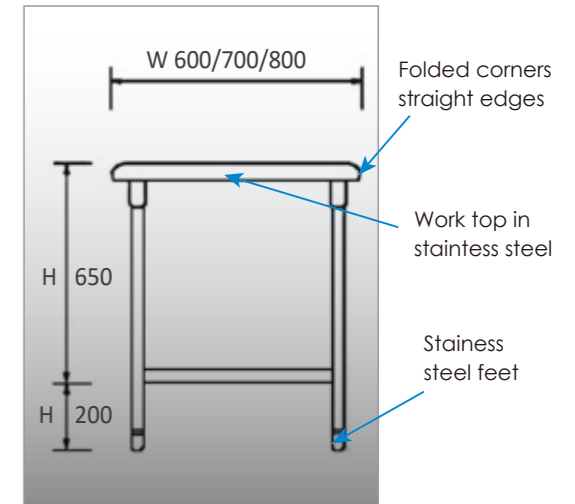

Central table+Splashback

600 Series Work Tables			
	Central table	Central table+Splashback	Optional
L x W x H mm	Model	Model	
900 x 600 x 850	BV600-90A	BV600-90AB	Wheels, Stainless Steel Drawer Assembly
1200 x 600 x 850	BV600-120A	BV600-120AB	Wheels, Stainless Steel Drawer Assembly
1500 x 600 x 850	BV600-150A	BV600-150AB	Wheels, Stainless Steel Drawer Assembly
1800 x 600 x 850	BV600-180A	BV600-180AB	Wheels, Stainless Steel Drawer Assembly
2100 x 600 x 850	BV600-210A	BV600-210AB	Wheels, Stainless Steel Drawer Assembly

700 Series Work Tables			
	Central table	Central table+Splashback	Optional
L x W x H mm	Model	Model	
900 x 700 x 850	BV700-90A	BV700-90AB	Wheels, Stainless Steel Drawer Assembly
1200 x 700 x 850	BV700-120A	BV700-120AB	Wheels, Stainless Steel Drawer Assembly
1500 x 700 x 850	BV700-150A	BV700-150AB	Wheels, Stainless Steel Drawer Assembly
1800 x 700 x 850	BV700-180A	BV700-180AB	Wheels, Stainless Steel Drawer Assembly
2100 x 700 x 850	BV700-210A	BV700-210AB	Wheels, Stainless Steel Drawer Assembly

800 Series Work Tables			
	Central table	Central table+Splashback	Optional
L x W x H mm	Model	Model	
900 x 800 x 850	BV800-90A	BV800-90AB	Wheels, Stainless Steel Drawer Assembly
1200 x 800 x 850	BV800-120A	BV800-120AB	Wheels, Stainless Steel Drawer Assembly
1500 x 800 x 850	BV800-150A	BV800-150AB	Wheels, Stainless Steel Drawer Assembly
1800 x 800 x 850	BV800-180A	BV800-180AB	Wheels, Stainless Steel Drawer Assembly
2100 x 800 x 850	BV800-210A	BV800-210AB	Wheels, Stainless Steel Drawer Assembly

- ▶ Heavy duty customized work table suitable for a variety of kitchen types.
- ▶ Adjustable feet to suit unflat floor. 1mm thickness stainless steel table top has curved edges for safety.
- ▶ A smooth work surface is ideal for preparing and processing sauces, meats and vegetable, and is large enough to complete most arts and crafts projects.

- ▶ Adjustable stainless steel shelf fits under the table and provides additional storage space for supplies.
- ▶ Optional splashback are hygienic and professional, practical, reliable and great value.
- ▶ Suitable for work, kitchen, restaurants and food preparation.

Assembling 2 Deck Working Table



Central table+Splashback

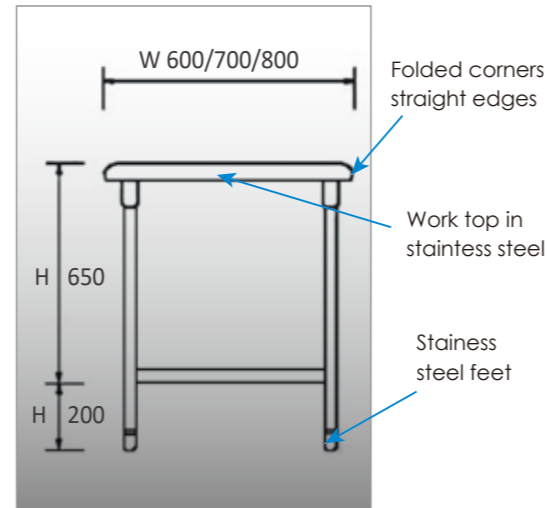

L x W x H mm	600 Series Work Tables		Optional
	Central table Model	Central table+Splashback Model	
900 x 600 x 850	BV600-90AL	BV600-90BL	Wheels, Stainless Steel Drawer Assembly
1200 x 600 x 850	BV600-120AL	BV600-120BL	Wheels, Stainless Steel Drawer Assembly
1500 x 600 x 850	BV600-150AL	BV600-150BL	Wheels, Stainless Steel Drawer Assembly
1800 x 600 x 850	BV600-180AL	BV600-180BL	Wheels, Stainless Steel Drawer Assembly
2100 x 600 x 850	BV600-210AL	BV600-210BL	Wheels, Stainless Steel Drawer Assembly

L x W x H mm	700 Series Work Tables		Optional
	Central table Model	Central table+Splashback Model	
900 x 700 x 850	BV700-90AL	BV700-90BL	Wheels, Stainless Steel Drawer Assembly
1200 x 700 x 850	BV700-120AL	BV700-120BL	Wheels, Stainless Steel Drawer Assembly
1500 x 700 x 850	BV700-150AL	BV700-150BL	Wheels, Stainless Steel Drawer Assembly
1800 x 700 x 850	BV700-180AL	BV700-180BL	Wheels, Stainless Steel Drawer Assembly
2100 x 700 x 850	BV700-210AL	BV700-210BL	Wheels, Stainless Steel Drawer Assembly

L x W x H mm	800 Series Work Tables		Optional
	Central table Model	Central table+Splashback Model	
900 x 800 x 850	BV800-90AL	BV800-90BL	Wheels, Stainless Steel Drawer Assembly
1200 x 800 x 850	BV800-120AL	BV800-120BL	Wheels, Stainless Steel Drawer Assembly
1500 x 800 x 850	BV800-150AL	BV800-150BL	Wheels, Stainless Steel Drawer Assembly
1800 x 800 x 850	BV800-180AL	BV800-180BL	Wheels, Stainless Steel Drawer Assembly
2100 x 800 x 850	BV800-210AL	BV800-210BL	Wheels, Stainless Steel Drawer Assembly

- ▶ Heavy duty customized work table suitable for a variety of kitchen types.
- ▶ Adjustable feet to suit unflat floor. 1mm thickness stainless steel table top has curved edges for safety.
- ▶ A smooth work surface is ideal for preparing and processing sauces, meats and vegetable, and is large enough to complete most arts and crafts projects.

- ▶ Adjustable stainless steel shelf fits under the table and provides additional storage space for supplies.
- ▶ Optional splashback are hygienic and professional, practical, reliable and great value.
- ▶ Suitable for work, kitchen, restaurants and food preparation.

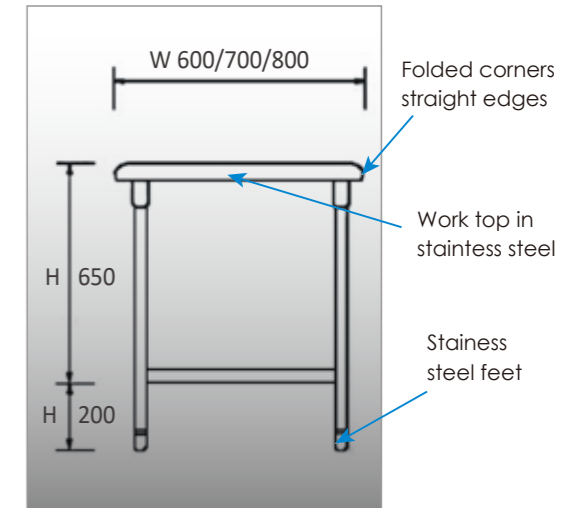

L x W x H mm	600 Series Work Tables		Optional
	Central table Model	Central table+Splashback Model	
900 x 600 x 850	BV600-90C	BV600-90CB	Wheels, Stainless Steel Drawer Assembly
1200 x 600 x 850	BV600-120C	BV600-120CB	Wheels, Stainless Steel Drawer Assembly
1500 x 600 x 850	BV600-150C	BV600-150CB	Wheels, Stainless Steel Drawer Assembly
1800 x 600 x 850	BV600-180C	BV600-180CB	Wheels, Stainless Steel Drawer Assembly
2100 x 600 x 850	BV600-210C	BV600-210CB	Wheels, Stainless Steel Drawer Assembly

L x W x H mm	700 Series Work Tables		Optional
	Central table Model	Central table+Splashback Model	
900 x 700 x 850	BV700-90C	BV700-90CB	Wheels, Stainless Steel Drawer Assembly
1200 x 700 x 850	BV700-120C	BV700-120CB	Wheels, Stainless Steel Drawer Assembly
1500 x 700 x 850	BV700-150C	BV700-150CB	Wheels, Stainless Steel Drawer Assembly
1800 x 700 x 850	BV700-180C	BV700-180CB	Wheels, Stainless Steel Drawer Assembly
2100 x 700 x 850	BV700-210C	BV700-210CB	Wheels, Stainless Steel Drawer Assembly

L x W x H mm	800 Series Work Tables		Optional
	Central table Model	Central table+Splashback Model	
900 x 800 x 850	BV800-90C	BV800-90CB	Wheels, Stainless Steel Drawer Assembly
1200 x 800 x 850	BV800-120C	BV800-120CB	Wheels, Stainless Steel Drawer Assembly
1500 x 800 x 850	BV800-150C	BV800-150CB	Wheels, Stainless Steel Drawer Assembly
1800 x 800 x 850	BV800-180C	BV800-180CB	Wheels, Stainless Steel Drawer Assembly
2100 x 800 x 850	BV800-210C	BV800-210CB	Wheels, Stainless Steel Drawer Assembly

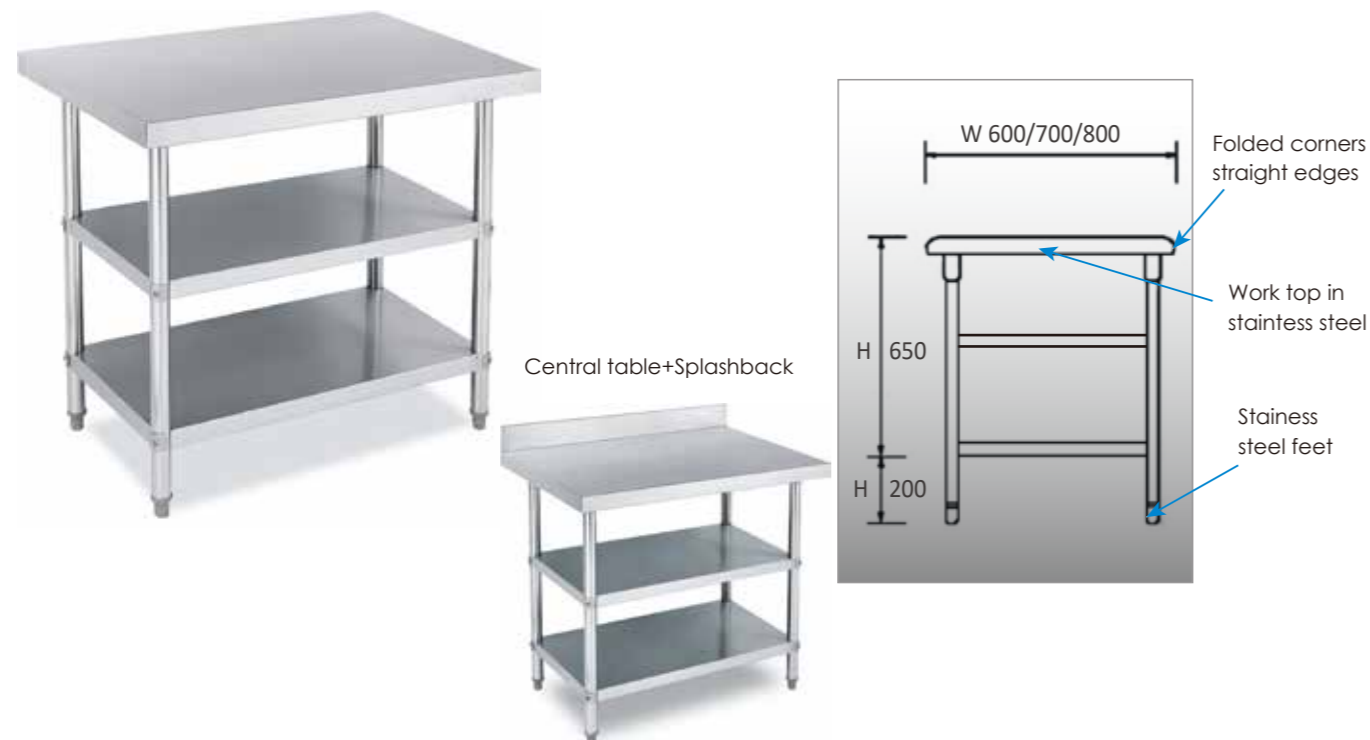

Central table+Splashback

600 Series Work Tables

L x W x H mm	Central table	Central table+Splashback	Optional
	Model	Model	
900 x 600 x 850	BV600-90A2	BV600-90AB2	Wheels, Stainless Steel Drawer Assembly
1200 x 600 x 850	BV600-120A2	BV600-120AB2	Wheels, Stainless Steel Drawer Assembly
1500 x 600 x 850	BV600-150A2	BV600-150AB2	Wheels, Stainless Steel Drawer Assembly
1800 x 600 x 850	BV600-180A2	BV600-180AB2	Wheels, Stainless Steel Drawer Assembly
2100 x 600 x 850	BV600-210A2	BV600-210AB2	Wheels, Stainless Steel Drawer Assembly

700 Series Work Tables

L x W x H mm	Central table	Central table+Splashback	Optional
	Model	Model	
900 x 700 x 850	BV700-90A2	BV700-90AB2	Wheels, Stainless Steel Drawer Assembly
1200 x 700 x 850	BV700-120A2	BV700-120AB2	Wheels, Stainless Steel Drawer Assembly
1500 x 700 x 850	BV700-150A2	BV700-150AB2	Wheels, Stainless Steel Drawer Assembly
1800 x 700 x 850	BV700-180A2	BV700-180AB2	Wheels, Stainless Steel Drawer Assembly
2100 x 700 x 850	BV700-210A2	BV700-210AB2	Wheels, Stainless Steel Drawer Assembly

800 Series Work Tables

L x W x H mm	Central table	Central table+Splashback	Optional
	Model	Model	
900 x 800 x 850	BV800-90A2	BV800-90AB2	Wheels, Stainless Steel Drawer Assembly
1200 x 800 x 850	BV800-120A2	BV800-120AB2	Wheels, Stainless Steel Drawer Assembly
1500 x 800 x 850	BV800-150A2	BV800-150AB2	Wheels, Stainless Steel Drawer Assembly
1800 x 800 x 850	BV800-180A2	BV800-180AB2	Wheels, Stainless Steel Drawer Assembly
2100 x 800 x 850	BV800-210A2	BV800-210AB2	Wheels, Stainless Steel Drawer Assembly

Assembling 2Deck Working Table With 1Deck Shelf



LxDxH/BxTxH mm	Central tables	Ref.
	1200 x 800 x (850+660)	
1500 x 800 x (850+660)		BV800-150A3
1800 x 800 x (850+660)		BV800-180A3

LxDxH/BxTxH mm	Central tables	Central tables +low shelf
	Ref.	Ref.
900 x 600 x (850+550)	BV600-90B2	BV700-90B2
1200 x 600 x (850+550)	BV600-120B2	BV700-120B2
1500 x 600 x (850+550)	BV600-150B2	BV700-150B2
1800 x 600 x (850+550)	BV600-180B2	BV700-180B2

Table shelf (flr tables with straight or rounded edges)

1SHELF



2 SHELVES

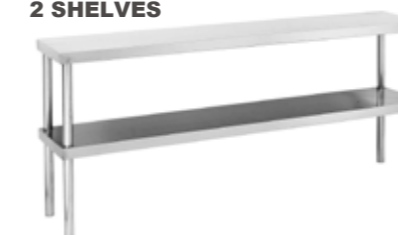

1SHELF	
LxDxH/BxTxH mm	Ref.
1000 x 300 x 400	EGS110
1200 x 300 x 400	EGS112
1400 x 300 x 400	EGS114
1600 x 300 x 400	EGS116
1800 x 300 x 400	EGS118
2000 x 300 x 400	EGS120

2 SHELVES	
LxDxH/BxTxH mm	Ref.
1000 x 300 x 600	EGS210
1200 x 300 x 600	EGS212
1400 x 300 x 600	EGS214
1600 x 300 x 600	EGS216
1800 x 300 x 600	EGS218
2000 x 300 x 600	EGS220

Assembling 2 Deck Corner Working Table



	LxDxH/BxTxH mm	Ref.
600 Series Work Tables	900 x 600 x (900+100)	BV600-90BS
700 Series Work Tables	900 x 700 x (900+100)	BV700-90BS

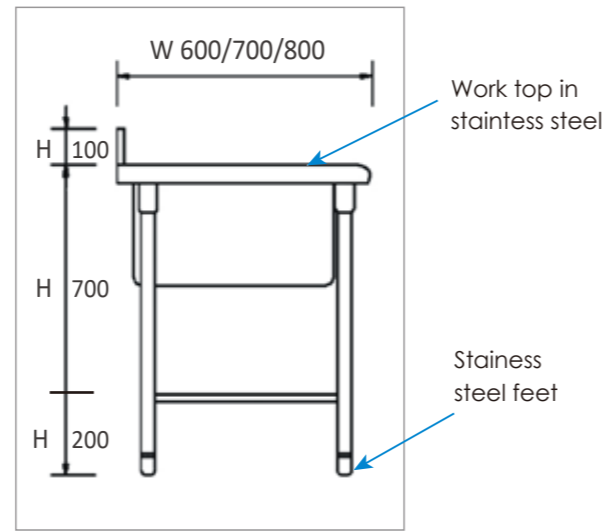

Assembling 1-Sink Table
BV6 series sink size: 400x400x280mm
BV7 series sink size: 500x500x300mm

	L x W x H mm	Model	L x W x H mm	Model
1 sink	600 x 600 x (900+100)	BV6-60-1	600 x 700 x (900+100)	BV7-60-1
Center sink	1200 x 600 x (900+100)	BV6-120-1C	1200 x 700 x (900+100)	BV7-120-1C
Left sink	1200 x 600 x (900+100)	BV6-120-1L	1200 x 700 x (900+100)	BV7-120-1L
Right sink	1200 x 600 x (900+100)	BV6-120-1R	1200 x 700 x (900+100)	BV7-120-1R
Center sink	1500 x 600 x (900+100)	BV6-150-1C	1500 x 700 x (900+100)	BV7-150-1C
Left sink	1500 x 600 x (900+100)	BV6-150-1L	1500 x 700 x (900+100)	BV7-150-1L
Right sink	1500 x 600 x (900+100)	BV6-150-1R	1500 x 700 x (900+100)	BV7-150-1R
Center sink	1800 x 600 x (900+100)	BV6-180-1C	1800 x 700 x (900+100)	BV7-180-1C
Left sink	1800 x 600 x (900+100)	BV6-180-1L	1800 x 700 x (900+100)	BV7-180-1L
Right sink	1800 x 600 x (900+100)	BV6-180-1R	1800 x 700 x (900+100)	BV7-180-1R
Center sink	2100 x 600 x (900+100)	BV6-210-1C	2100 x 700 x (900+100)	BV7-210-1C
Left sink	2100 x 600 x (900+100)	BV6-210-1L	2100 x 700 x (900+100)	BV7-210-1L
Right sink	2100 x 600 x (900+100)	BV6-210-1R	2100 x 700 x (900+100)	BV7-210-1R

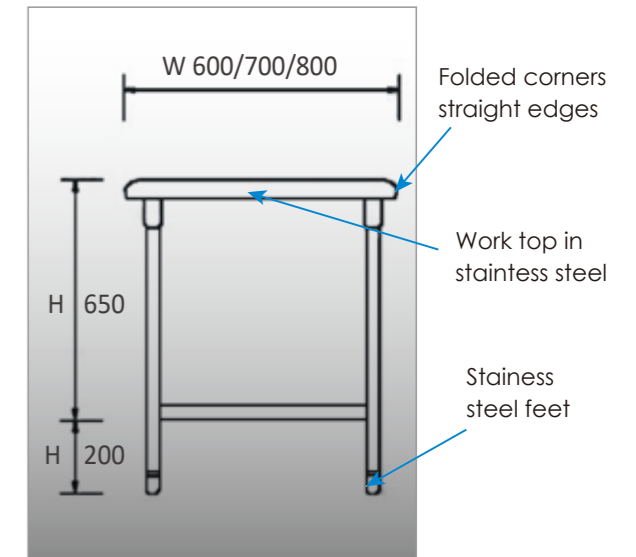

Assembling 1-Sink Table

	Sink Dimension(mm)	Dimension LxWxH(mm)	Model
1 sink	400x400x280mm	600 x 600 x (850+100)	BV-78
2 sinks	400x400x280mm	1100 x 600 x (850+100)	BV-80
2 sinks	400x400x280mm	1500 x 600 x (850+100)	BV-82
2 sinks	400x400x280mm	1800 x 600 x (850+100)	BV-84
1 sink	500x500x280mm	700 x 700 x (850+100)	BV-79
2 sinks	500x500x280mm	1200 x 700 x (850+100)	BV-81
2 sinks	500x500x280mm	1500 x 700 x (850+100)	BV-83
2 sinks	500x500x280mm	1800 x 700 x (850+100)	BV-85
3 sinks	500x500x280mm	1800 x 700 x (850+100)	BV-86
3 sinks	500x500x280mm	2200 x 700 x (850+100)	BV-87

▶ Draining board: grooved with non-drip edges

Assembling Sink Table



	Sink Dimension(mm)	Dimension LxWxH(mm)	Ref.
Assembling 1-Sink Table	400 x 400 x 280	1500 x 600 x (850+100)	BV-77
	400 x 400 x 280	1200 x 600 x (850+100)	BV-76

Assembling 2-Sink Table

▶ Draining board: grooved with non-drip edges



	Dimension LxWxH(mm)	600 Series Work Tables	700 Series Work Tables
		Ref.	Ref.
Assembling 2-Sink Table Sink Size: 450x450x300mm	1200 x 600/700 x (850+100)	BV6-120-2	BV7-120-2
	1500 x 600/700 x (850+100)	BV6-150-2	BV7-150-2
	1800 x 600/700 x (850+100)	BV6-180-2	BV7-180-2
	2100 x 600/700 x (850+100)	BV6-210-2	BV7-210-2

Assembling 3-Sink Table

▶ Draining board: grooved with non-drip edges



	Sink Size(mm)	Dimension LxWxH(mm)	Ref.
Assembling 3-Sink Table	420 x 250 x 350	1050 x 610 x (900+200)	BV-76B1
	420 x 250 x 350	1300 x 610 x (900+200)	BV-76B2
	420 x 250 x 350	1500 x 610 x (900+200)	BV-76B3

▶ Draining board: grooved with non-drip edges



	Sink Dimension(mm)	Dimension LxWxH(mm)	Ref.
Assembling 1-Sink Table	500 x 500 x 280	1500 x 700 x (850+100)	BV-76A1



	Sink Dimension(mm)	Dimension LxWxH(mm)	Ref.
Assembling 2-Sink Table	500 x 500 x 280	1800 x 700 x (850+100)	BV-76A2



	Sink Dimension(mm)	Dimension LxWxH(mm)	Ref.
Assembling 3-Sink Table	500 x 500 x 280	2000 x 700 x (850+100)	BV-76A3

Knee Operated Wash Basin

- ▶ SS201+SS304
- ▶ Thickness:1.0mm



	Sink Dimension(mm)	Dimension LxWxH(mm)	Ref.
without accessory	330x232x130	400x330x570	F-W
with accessories-only cold water	330x232x130	400x330x570	F-L
with accessories-warm and cold water adjusted	330x232x130	400x330x570	F-LR

- ▶ Sink: SS 304, 0.9mm thickness
- ▶ Lateral board: SS 201, 0.6mm thickness
- ▶ Accessories included

	Sink Dimension(mm)	Dimension LxWxH(mm)	Ref.
only cold water	350x350	400x400x225	Y-LR
warm and cold water adjusted	350x350	400x400x225	Y-L

Stainless Steel Cabinet



Dimension LxWxH(mm)	Ref.
1800 x 800 x 850	BV-43

Dimension LxWxH(mm)	Ref.
1800 x 750 x (850+100)	BV-44

Dimension LxWxH(mm)	Ref.
1200 x 350 x 600	BV-45
1500 x 350 x 600	BV-46
1800 x 350 x 600	BV-47

Upright Cabinet



Dimension LxWxH(mm)	Ref.
1500 x 700 x 850	BV-50
1800 x 700 x 850	BV-51

Cabinet With Shelve



Dimension LxWxH(mm)	Ref.
1500 x 700 x (850+1000)	BV-52
1800 x 700 x (850+1000)	BV-53

Mobil cabinet with drawers



Dimension LxWxH(mm)	Ref.
1160 x 540 x 1400	BV-M1

Mobil Bin Station



Dimension LxWxH(mm)	Ref.
1180 x 550 x 1260	BV-M2

Kitchen Desk With Splashback



Cubic(m3)	Net Weight(kg)	Dimension LxWxH(mm)	Ref.
1.28	67	1500X750X850+100	LR84-75-1500
1.5	70	1800X750X850+100	LR84-75-1800

Kitchen Bench With 3 Drawers & Under Shelf



Cubic(m3)	Net Weight(kg)	Dimension LxWxH(mm)	Ref.
1.28	87	1800 x 800 x 850	LR84-75-1500
1.28	87	1800 x 800 x 850	LR84-75-1500

Mobile Cabinet With 3 Drawers



Cubic(m3)	Net Weight(kg)	Dimension LxWxH(mm)	Ref.
0.28	33	600X600X850	LR88-600
0.32	38	700X600X850	LR88-700

Mobile Cabinet With Drawers & Under Shelf



Cubic(m3)	Net Weight(kg)	Dimension LxWxH(mm)	Ref.
0.14	22	750X600X700	LR89-750

Mobile Bench With Under Bench Racks



Cubic(m3)	Net Weight(kg)	Dimension LxWxH(mm)	Ref.
0.1	30	750X50X700	LR90-750

Upright Cabinet



Dimension LxWxH(mm)	Ref.
1200 x 600 x 1800	BV-48

Extraction Canopy



Dimension LxWxH(mm)	Ref.
Length (Custom-made) x 1200x600	BV-104

Wall Shelve



Dimension LxWxH(mm)	Ref.	Ref.
1200 x 350 x 300	BV-94	BV-94A
1500 x 350 x 300	BV-95	BV-95A
1800 x 350 x 300	BV-96	BV-96A



Cubic(m3)	Net Weight(kg)	Dimension LxWxH(mm)	Ref.
0.02	3	600X350X300	LR86-35-600
0.03	4	900X350X300	LR86-35-900
0.04	6	1200X350X300	LR86-35-1200
0.05	7	1500X350X300	LR86-35-1500
0.06	8	1800X350X300	LR86-35-1800
0.07	9	2100X350X300	LR86-35-2100
0.08	11	2400X350X300	LR86-35-2400

Cubic(m3)	Net Weight(kg)	Dimension LxWxH(mm)	Ref.
0.02	1.6	600X350X300	LR87-35-600
0.03	2.5	900X350X300	LR87-35-900
0.04	3.2	1200X350X300	LR87-35-1200
0.05	4	1500X350X300	LR87-35-1500
0.06	4.8	1800X350X300	LR87-35-1800
0.07	5.6	2100X350X300	LR87-35-2100
0.08	6.4	2400X350X300	LR87-35-2400

Stainless Steel Shelving System

Stainless steel shelves refer to all kinds of stainless steel appliances for storage and display of goods. In order to adapt to the new situation or to make full use of space, it is convenient for the goods to be distinguished.

To improve the space utilization rate, the need for business office or warehouse for repairing and adjusting the shelves, counters and other major commodity display apparatus. Make a new appearance of a business hall or a warehouse



4 Shelves Shelving

Easy-Clean Stainless Steel Shelves
Non-slip rubber feet

Item No.	Dimensions
BV-70	1100x500x1550mm
BV-71	1500x500x1550mm



3 Shelves Shelving

Easy-Clean Stainless Steel Shelves
Non-slip rubber feet

Item No.	Dimensions
BV-74	1100x500x1800mm
BV-75	1500x500x1800mm



3 Shelves Shelving

Easy-Clean Stainless Steel Shelves
Non-slip rubber feet

Item No.	Dimensions
BV-72	1100x500x1550mm
BV-73	1500x500x1550mm

LINKRICH

Buffet Trolley & Bench

Buffet Trolley



Cubic(m3)	Net Weight(kg)	Dimension LxWxH(mm)	Ref.
0.17	37	900X700X1520	LR49B

Condiment Bench



Cubic(m3)	Net Weight(kg)	Dimension LxWxH(mm)	Ref.
0.16	13	600X600X840	LR-49C-6-600
0.24	19	900X600X840	LR-49C-6-900

Waste Collector Bench



Cubic(m3)	Net Weight(kg)	Dimension LxWxH(mm)	Ref.
0.1	16	900X600X850+100	LR26-6-900
0.14	20	1200X600X850+100	LR26-6-1200
0.17	24	1500X600X850+100	LR26-6-1500
0.2	28	1800X600X850+100	LR26-6-1800
0.24	32	2100X600X850+100	LR26-6-2100

Preparation Bench with Cutting Board



Cubic(m3)	Net Weight(kg)	Dimension LxWxH(mm)	Ref.
0.09	16	600X600X850+100	LR26-6-600
0.14	23	900X600X850+100	LR26-6-900
0.19	31	1200X600X850+100	LR26-6-1200
0.24	39	1500X600X850+100	LR26-6-1500
0.29	46	1800X600X850+100	LR26-6-1800

Work Bench with Overshelves



Cubic(m3)	Net Weight(kg)	Dimension LxWxH(mm)	Ref.
0.25	60	1200X850X2100	LR18B-1200
0.34	69	1500X950X2100	LR18B-1500
0.45	80	1800X1050X2100	LR18B-1800

Bar Bench & Steam Frame

LINKRICH

Cabinet with doors drawer splash back



Cubic(m3)	Net Weight(kg)	Dimension LxWxH(mm)	Ref.
0.84	58	1200X600X850+100	LR97-6-1200
1.04	64	1500X600X850+100	LR97-6-1500
1.25	70	1800X600X850+100	LR97-6-1800

Desk with under shelf and splash back



Cubic(m3)	Net Weight(kg)	Dimension LxWxH(mm)	Ref.
0.84	46	1200X600X850+100	LR98-6-1200
1.04	49	1500X600X850+100	LR98-6-1500
1.25	50	1800X600X850+100	LR98-6-1800

Bar Bench with Drawer



Cubic(m3)	Net Weight(kg)	Dimension LxWxH(mm)	Ref.
0.72	58	2000x620x900+100	LR44B-6-2000
0.88	65	2500x620x900+100	LR44B-6-2500
1.05	73	3000x620x900+100	LR44B-6-3000

5 Level Steam Frame



Cubic(m3)	Net Weight(kg)	Dimension LxWxH(mm)	Ref.
0.43	6	610X430X1550	LR92-5