SH530
Respiratory Tract Humidifier for
Medical Use

Operating Manual

Revision D

Content

Content.....	I
Cautions.....	III
Attentions.....	V
1 Introduction.....	1
2 Working Principle	2
3 Technical Characteristics.....	3
4 Weight & Dimensions.....	6
5 Equipment Installation & Adjustment.....	7
6 Basic Steps.....	10
7 Alarm.....	15
8 Service and Periodic Check.....	19
9 Cleaning , Disinfection & Maintenance.....	23
10 Environmental Protection.....	25
11 Transportation & Storage.....	26
Appendix A.....	27
Appendix B.....	31

Revision	Description of Operating Manual Change	Date Issued
A	First release operating manual	2011.11.4
B	Add AC indicator to Figure 5-1 in 5.3 and change power indicator to working indicator, amend other related contents. Add 8.7 Periodic Safety Checks. Add Appendix B: EMC information	2011.12.5
C	Amend 3.9, the low temperature alarm parameter. Accordingly, amend Table 7-1 Alarm Summary Table in 7.1	2012.4
D	Symbols , add and modify some symbols 1.3 , add pollution degree, overvoltage category and altitude 3.2 and 3.3 , modify some indexes 5.3 , the mute button is replaced by audio paused button, on the basis of IEC60601-1-8 9 , delete the contents of the disinfections of shell and power cable Appendix A , modify the table A-2 and figure A-2	2014.4

Cautions



Consult accompanying documents.

- . **SH530** Respiratory Humidifier can only be operated by appointed personnel.
- . Take care of explosion-proof. Don't use **SH530** Respiratory Humidifier near flammable anesthetic.
- . Read carefully of this manual and all manuals of accessories, attentions and warnings before using. Users must check the safety of this manual to ensure it is in complete and good working conditions.
- . Maintenance, covering or random removal of this instrument is prohibited when it is connected with patients.
- . Don't open the shell without permission. Internal problem shall be maintained by the manufacturer accredited personnel. If the unaccredited personnel maintain the humidifier, it may be damaged.
- . Clinic safety has been carefully considered during design, but the operator shall not neglect to observe the status of the instrument and the patient's nursing.
- . Take care of the prevention of collision or acute shake.
- . Setting the cable and whorl pipe carefully and avoid winding or choking the patients.
- . The power cable of **SH530** Humidifier can only be connected to the standard socket in hospital.
- . **SH530** Humidifier storage environment: temperature ($-10^{\circ}\text{C}\sim 50^{\circ}\text{C}$) , RH ($\leq 93\%$) , atmospheric pressure ($50\text{kPa}\sim 106\text{kPa}$) . No corrosion. Any excess may damage the system.
- . When voltage fluctuation of mains exceeds 10%, it is suggested to use AC stabilizer.
- . **SH530** humidifier is an instrument of Class I with Type BF applied part. So it is also necessary to ensure the earth of machine's rear wires in good condition!
- . Users shall choose the power supply on the nameplate of humidifier.
- . The power supply system shall be coincided with the local national electrical safety standards.
- . When humidifier is starting to operate, we test the alarm system by not inserting the sensors or unplugging the sensors.
- . All the parts of chamber and heater wires can only be sterilized for 100 times.

. For details of each start-up, see chapters 5 and 6.

Symbols:



Type BF



Do not discard
WEEE collection

IPX1

Drip-proof
protection to IPX1



Caution: Hot surfaces
may exceed 85°C



Electric Shock Hazard



Date of manufacture



CE marking



Follow operating
Instruction



Name and address
of the manufacturer



Serial Number



Name and address of the
authorized representative in
the European community



Lot Number

Attentions

Read this manual carefully before use. Follow the operation regulation strictly. Our company guarantees the quality of our products. Customers can put forth any enquiries when you met any problems in operation. We shall provide you the ardent service.

This manual provides all necessary information to meet the requirements of operating **SH530** Respiratory Humidifier.

Don't operate the machine before reading this manual!

In order to operate the equipment conveniently, there will be "attention" "note" "warning" appeared in this manual:

"Attention": To prevent errors in operation.

"Note": Indicate various functions and point out advanced features.

"Warning": Refers to possibilities of danger or equipment damages.

For information support or service please contact the local accredited organizations.

Attention: Only trained personnel can operate this humidifier according to this manual.

Warning: Do not modify this equipment without authorization of the manufacture

Packing & Transportation:

Move the equipment out of the transport packing and check if it is damaged. If there is any problem please keep all packing materials, bill of lading and other necessary explanatory materials then contact the local dealer in time.

Service:

Contact the local dealer for services needed. Before asking service please finish the adjustment operation to confirm the whole machine's status. Please also provide the machine's series number and the details of your problems.

Maintenance:

It is suggested that the local accredited professional serviceman perform such maintenance every 12 months.

Company: Wuxi Jike Electronics Co., Ltd.

Address: 2nd workshop floor & 3rd office floor of the 4th building,
NO. 29 Changjiang South Road, New District, 214028Wuxi,
Jiangsu Province, PEOPLE'S REPUBLIC OF CHINA

Tel: (86)-510-85228335

Fax: (86)-510-85223855

Website: <http://www.jike-medical.com>

E-mail: wuxijike@sohu.com

Information of Authorized EC Representative:

Name: Wellkang Ltd

Address: Suite B, 29 Harley Street LONDON W1G 9QR, England,
United Kingdom

1 Introduction

1.1 Intended Use

SH530 Respiratory Humidifier is designed for ventilators or other positive pressure systems to warm and humidify the airflow. The airflow is warmed and humidified by ventilating through the warm water's surface. Reducing the stimulation to the cardiopulmonary system produced by the mechanical ventilation, keeping the pulmonary alveolus moist, being beneficial to sputum aspiration, preventing the airway obstruction. The temperature is regulated by setting up temperature setting button, and it also can be monitored alone.

With temperature digital display and overheating alarm and error indication function. Increase the security and intuitiveness, in favor of doctor's wardship. The system is intended to be used in a hospital environment by trained healthcare providers. It is suitable to use with high-quality ventilators in all levels of hospital. It shall be used on children and adults. It also can be used on the patient whose upper respiratory tract is bypassed.

It is used with ventilators or other positive pressure systems to warm and humidify the airflow.

Contraindication: No

Applied part: all the breathing tubes connecting to the patient port

1.2 Main Functions

SH530 Respiratory Humidifier has 3 steps to control the temperature range with the function of overheating protection, working in both heater wire and non-heater wire model. Used with the heater wire breathing circuit.

1.3 Classification

Product safety: Comply with IEC60601-1&ISO8185

Degree of Protection Against Electric Shock: Type BF

Type of Protection Against Electric Shock: Class I

Degree of Protection Against Ingress of Water: Drip-proof IPX1

Protection Against Inflammable Anesthetic Gases:

no Category AP/APG

not intended for use in oxygen rich environment

Operation Mode: Continuous Operation

Pollution degree: 2

Overvoltage category: II

Altitude: $\leq 2000\text{m}$

1.4 Structures

SH530 Respiratory Humidifier is composed of the main frame of humidifier, chamber, temperature sensors, heater wires and connectors; hanging and digital

display type.

1.5 Others

Refer to relevant contents in chapters 2~11 for more details.

2 Working Principle

The schematic figure of the machine is shown in the following:

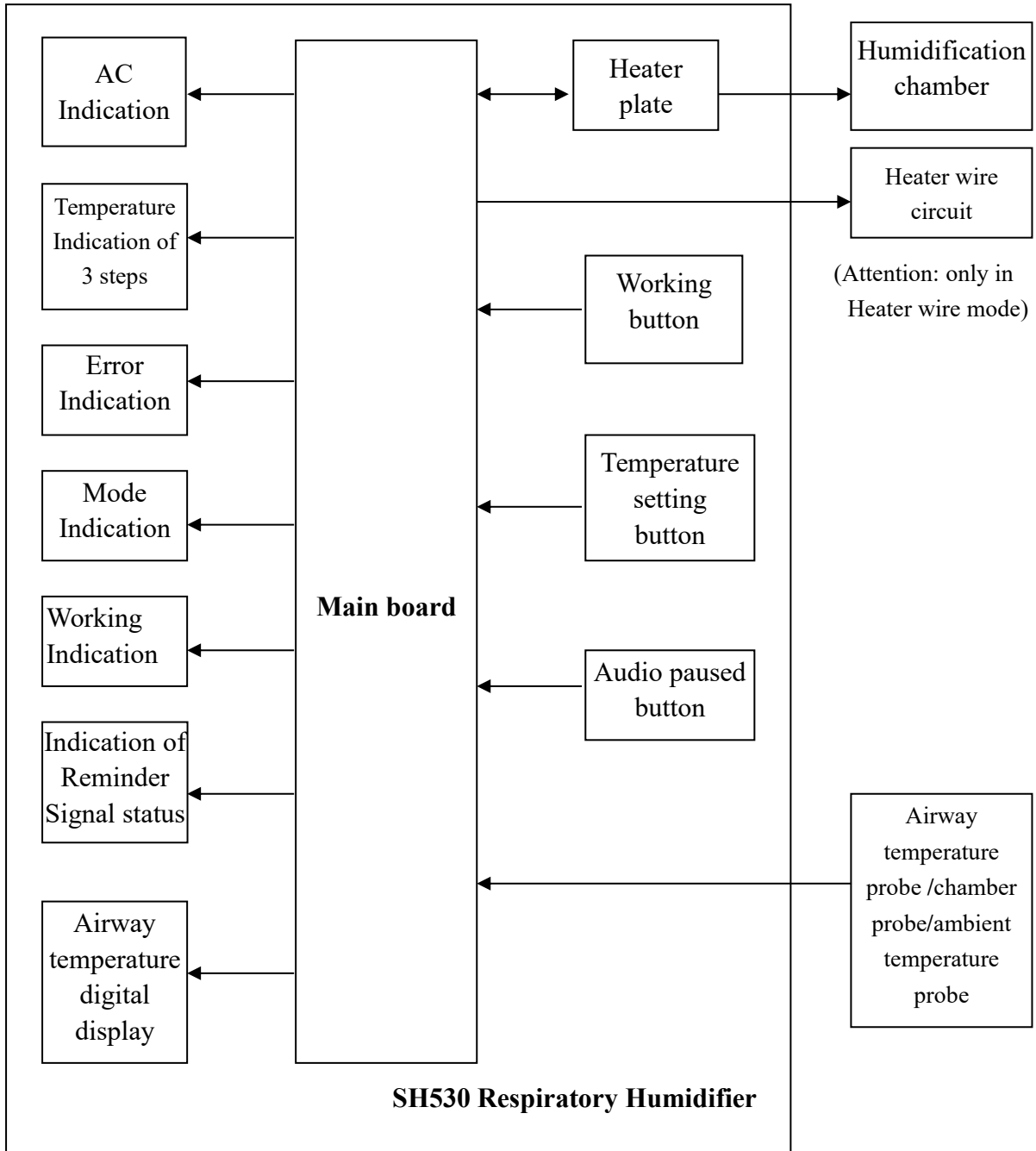

Fig. 2-1 SH530 Respiratory Humidifier

3 Technical Characteristics

3.1 Working condition

Temperature	18°C~26°C
Relative humidity	≤80%
Atmospheric pressure	86kPa~106kPa
Operating gas inlet temperature	18°C~26°C

Attention: The operating temperature over the recommended one may affect the performance.

3.2 Range of temperature control:

a) Control Performance of Dynamic Temperature

We get data in table 3-1, table 3-2 under the following test conditions.

Test conditions:

- (1) The testing working Temperature: 18°C~26°C,
Temperature of input gas: 18°C~26°C.
- (2) Pipeline requirements:

Heater wire mode: Φ22mm×1500mm silica gel tubes with heater wires,

Non-heater wire mode: Φ22mm×600mm+Φ22mm×900mm silica gel tubes.

- (3) Type of humidification chamber: SH360

Table 3-1 Heater wire mode

Temperature setting steps (vision state of indicators)	The range of continuous flow	Air temperature control range of the input port of patient
Low (● ○ ○)	5L/min~40L/min	25°C~29°C
Medium (● ● ○)	5L/min~40L/min	30°C~34°C
High (● ● ●)	5L/min~40L/min	35°C~39°C

Table 3-2 Non-Heater wire mode

Temperature setting steps (vision state of indicators)	The range of continuous flow	Air temperature control range of the input port of patient
Low (● ○ ○)	5L/min~40L/min	24°C~28°C
Medium (● ● ○)	5L/min~40L/min	28°C~32°C
High (● ● ●)	5L/min~40L/min	32°C~36°C

Attention: ● Indicator on ○ Indicator off

3.3 Humidification system output

The output shall meet the requirements in table 3-3.

Attention: the test condition is the same as the above one.

Table 3-3 system output

Temperature setting steps (vision state of indicators)	The range of continuous flow	Output(mg/L)
Low (● ○ ○)	5L/min~40L/min	> 10mg/L
Medium (● ● ○)	5L/min~30L/min	> 22mg/L
High (● ● ●)	5L/min~25L/min	> 33mg/L

Warning: The performance of our humidification system will degrade and the output may exceed the requirement of table 3-3, if the flow and temperature exceed the approved ones.

Note: The high step is used with patients whose upper airways are bypassed, the range of continuous flow are 5L/min~25L/min.

3.4 Electrical performance

NO.	Power supply	Rated frequency	Fuse capacity
1	110V~	50/60Hz	T 3A H 250VAC
2	230V~	50/60Hz	T 2A H 250VAC

Power input	220VA
Heater plate capacity	150W
Heater wire	22VAC 60W Max
Heater plate thermal cutout	120±5°C

3.5 Characteristics of the chamber

Max operate pressure	≤6kPa
Pressure drop	<0.2kPa(the flow is 60L/min)
Max volume	350mL
Adaptability	6mL/KPa~12mL/KPa
Leakage rate	≤10 mL/min

3.6 Test of the gas temperature in patient input port

Type	Panel digital display
Measuring range	10°C~50°C Temperature≤10°C, display L; Temperature≥50°C, display H;
Measuring accuracy	±2°C
Testing point	25mm away from the patient

3.7 warm-up time

The time required (warm-up time) for the measured gas temperature to reach the set temperature from a starting temperature of (23±2) °C shall be less than 30min.

3.8 Alarm Parameters

High Temperature Alarm: Cause an immediate, audible and visible alarm at a displayed temperature of 41°C.

Low Temperature Alarm:

Heater wire operation

High temperature step:

Fig 3-1 shows the relationship between the temperature of patient port and the ambient temperature.

Non-heater wire operation

High temperature step:

Fig 3-2 shows the relationship between the temperature of patient port and the ambient temperature.

Ambient temperature = T1, temperature of patient port \leq T2 for 10minutes, causes an audible and visible alarm. (In Fig 3-1 and 3-2, T2 is the corresponding patient port temperature of ambient temperature T1.)

They are disabled during warm-up conditions.

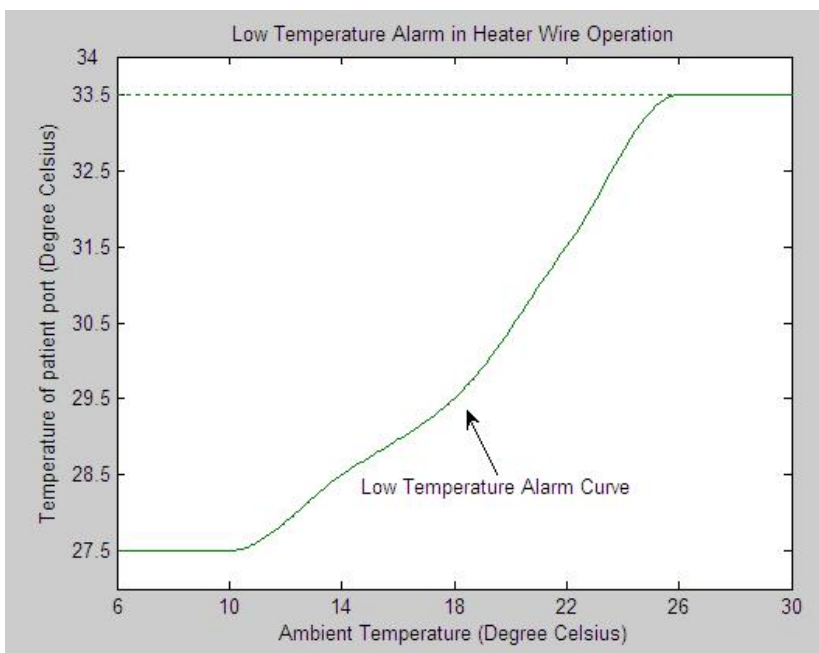

Fig. 3-1 Low Temperature Alarm in Heater Wire Operation

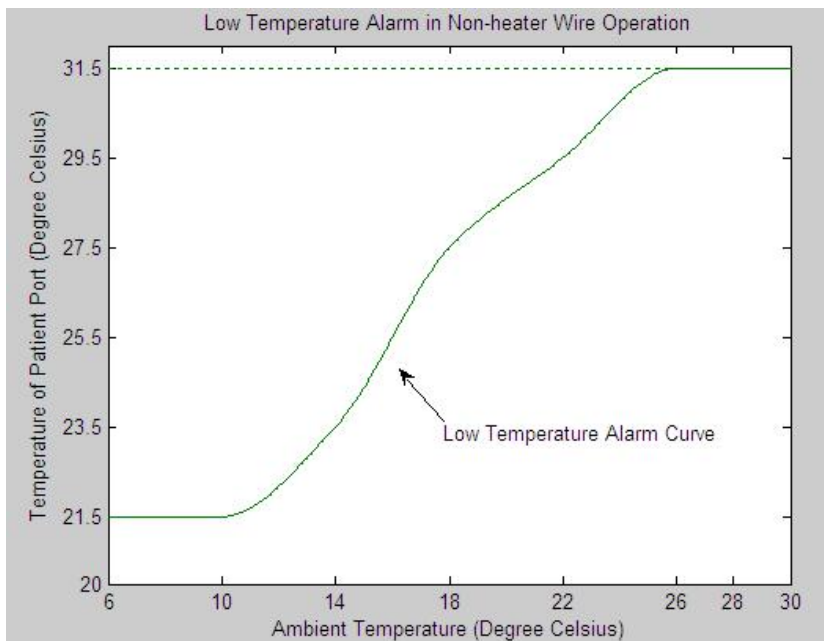

Fig. 3-2 Low Temperature Alarm in Non-heater Wire Operation

Sound Pressure Level: Alarms exceed 50 dBA@1m.

4. Weight & Dimensions

Dimensions 135mm(W)×145mm(H)×155mm(D)
(Without chamber fitted)

Weight 2.5kg (max) (without chamber fitted)
3.2kg (max) (with SH360 chamber fitted& filled with water)

5 Equipment Installation & Adjustment

Before starting the system, please keep up the following requirements to ensure the safety of patient, operator and equipment.

Attention: The working environment for SH530 Respiratory Humidifier shall comply with the following:

Temperature 18°C~26°C
Relative Humidity ≤80%
Atmospheric pressure 86KPa~106KPa

Attention: The operating temperature over the recommended one may affect the performance.

Warning: The power cable of SH530 Respiratory Humidifier can only be connected to the standard socket of the hospital.

Warning: The storage environment of SH530 Respiratory Humidifier: Temperature (-10°C~50°C) , RH (≤93%) , Atmospheric pressure (50KPa~106KPa) , no corrosion, any excess may damage the system.

Attention: When the machine is operated from the storage status to the working status and if the storage condition exceeded the working requirements then it is necessary to check if it is working properly and safely before using.

5.1 Installation site

It is forbidden to use the SH530 Respiratory Humidifier in flammable or explosive environment. SH530 Respiratory Humidifier must mate with the ventilator and be operated by well-trained medical personnel.

If the equipment is not working well please don't disassemble or assemble the system rudely. Just mark a warning on it and contact the accredited personnel for maintenance right away.

Warning: The functions of humidifier shall be badly affected when there is high frequency surgical apparatus, shortwave or microwave equipments operating nearby. If it occurs, we shall remove the humidifier away from these devices.

Warning: The performance of the humidification system may be badly affected when the system are exposed to environments of electrocautery, electrosurgery, defibrillation, X ray(γ ray), infrared radiation, transient electromagnetic field, including MRI and radio interference. So we shall remove the humidifier away from these environments.

Warning: Mains plug is intended to be used as the isolation means from the supply mains, please don't position the device so that it is difficult to operate the disconnection device.

Warning: The operator or patient may touch the enclosure of the humidifier and chamber, their materials are PC and PSU. They are safe enough to not cause harms to operator or patient.

5.2 Power supply requirement

SH530 Respiratory Humidifier must be connected to the power supply with a 3-line protective earth socket, and the earth must comply with the local national regulation. Please check if the voltage at site complies with the rated requirement on the humidifier nameplate or not. SH530 Respiratory Humidifier is connected with the power supply by its power cord.

Warning: Ensure the power supply comply with the requirement on the nameplate, otherwise it will damage the equipment.

warning: To avoid risk of electric shock, this equipment must only be connected to a supply mains with protective earth.

5.3 Operation interface

Connect SH530 with the power supply, then the AC indicator light. Front panel and sideboard are shown in figure 5-1, figure 5-2.

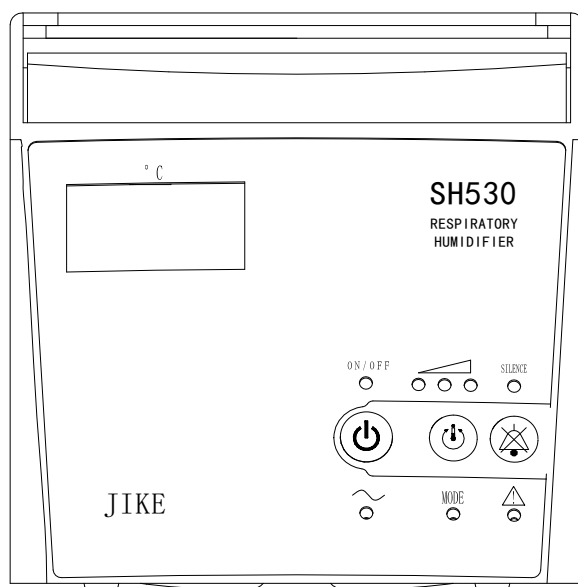







Fig.5-1

Working Button		Stand-by
Temperature setting button		Switch the temperature setting steps
Audio Paused button		Audio pause
Working Indicator	ON/OFF	Used to indicate the humidifier is working or not, the indicator color is green.

Mode Indicator MODE	Used to indicate the status of working mode, the indicator color is green.
Error Indicator 	Used to indicate that the humidifier is in error or abnormal state, see the indicator color in 7.1.
Heating step Indicator 	Used to indicate the heating status. There are three steps: “low”, “medium” and “high”. The indicator color is green.
Reminder Signal Indicator SILENCE	Used to indicate the reminder signal status. The indicator color is green.
Temperature display °C	Used to indicate the gas temperature of patient port.
AC Indicator 	Used to indicate the status of device connecting with AC, the indicator color is green.

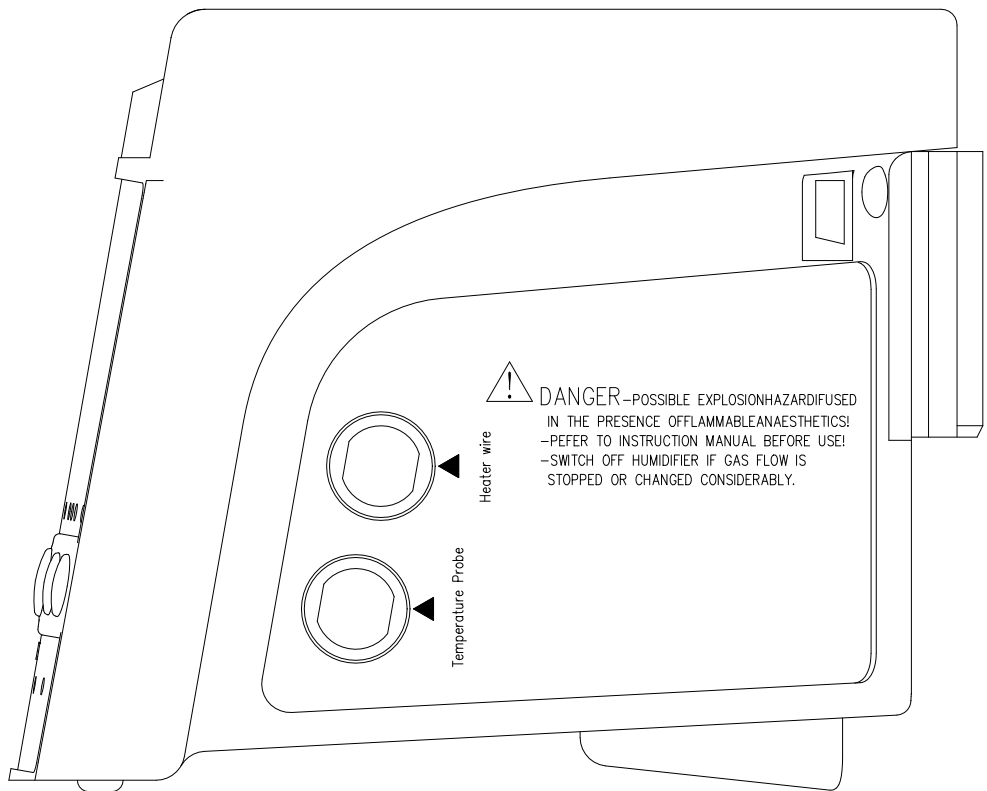

Fig.5-2

Heater wire socket HEATER WIRE	Output port of the heater wire tube
Temperature probe socket TEMPERATURE PROBE	Signal input port of the temperature probe of patient port, chamber port and ambient temperature

6 Basic Steps

6.1 Make some preparations before opening the machine

Warning: Check accessories for any physical damage before use and replace if damaged.

(1) Fixed SH530 Respiratory Humidifier on the bracket of ventilators, make sure SH530 Respiratory Humidifier should be lower than the patient.

(2) Ensure the humidification chamber and connection tubes clean and humidification chamber's bracket correctly installed before using.

(3) Pour water into the chamber between maximum and minimum level.

(4) Lay the humidification chamber on the chamber guard, and press the chamber guard down, then slide the chamber onto the heater plate. They are locked automatically, and the chamber guard will spring up automatically.

Warning: Don't fill the water exceeding the maximum level otherwise the water may spill into the breathing tube, and also do not below the minimum level.

Warning: Don't fill the water exceeding 37°C into the humidification chamber.

Warning: Quality water required: The distilled water is available otherwise the machine shall be affected.

Warning: Only use the assorted chamber for this humidifier (the recommended chamber is SH360).

Warning: Ensure the chamber with appropriate water is installed to the humidifier, or the humidifier will burn out after opening, causing the overheating protection relay cut off the power.

(5) Insert temperature probe into the socket with same color. Insert heater wire connector into the socket with the same color when entering the heater wire mode.

(6) Make the heater wire pass through the breathing tube correctly;

Specific methods are as follows:

(a) Make the stainless steel draw wire pass through the breathing tube.

(b) Make the stainless steel draw wire hook up one end of heater wire.

(c) Pull the draw wire along the breathing tube, until the breathing tube connector can be inserted into the elbow.

(7) Insert the airway adapter into the inlet of the chamber according to the arrow directions on top of the humidification chamber.

(8) Connect the airway inlet and outlet tubes of SH530 humidifier.

Warning: Range the breathing tube to make it collect water and drain out anytime.

Warning: We should not put things on the tubes.

Warning: We recommend breathing tubes with CE marking, our assorted chamber and connectors. The performance and using may be affected when using incompatible breathing tubes and accessories.

Warning: It may affect the performance of related equipment or damage it

when the recommended accessories are used with other humidifiers.

(9) Insert temperature sensors into the temperature sensor adapters of chamber port and patient port.

(System connection is shown in fig. 6-1, fig. 6-2, and fig. 6-3)

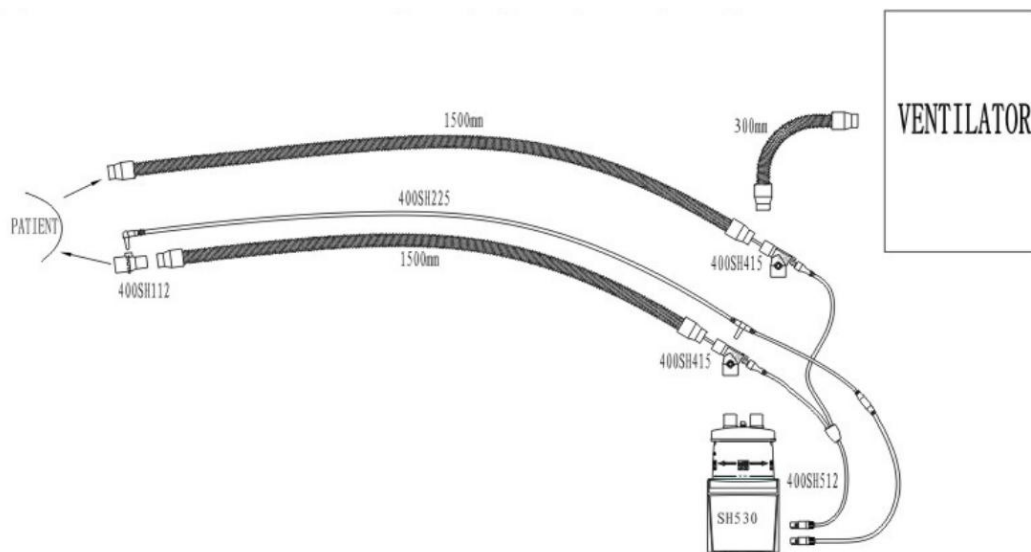

Fig. 6-1 the typical system (two tubes with heater wires)

Components in this system:

Humidification chamber: SH360

Respiratory tubes: silica gel tubes, the length is 1500mm

Temperature probe: 400SH225

Adapters: 400SH112

Heater wires: 400SH415

Heater wire adapters: 400SH512

We should choose the components according to the practical conditions.

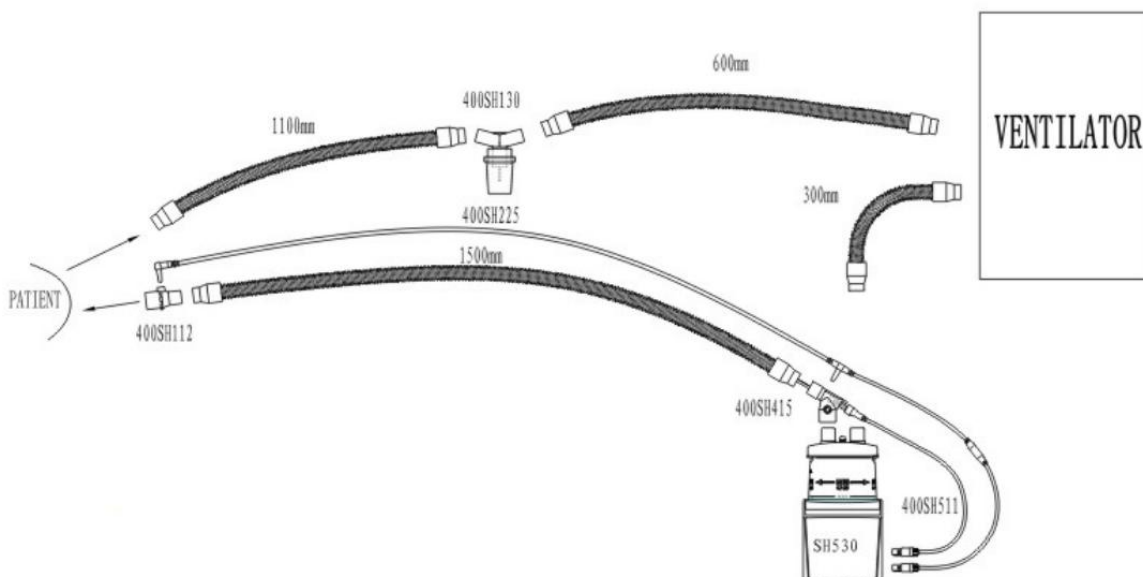

Fig. 6-2 the typical system (only one tube with heater wires)

Components in this system:

Humidification chamber: SH360

Respiratory tubes: silica gel tubes, the length is 1500mm, 1100mm+600mm

Temperature probe: 400SH225

Adapters: 400SH112

Heater wires: 400SH415

Heater wire adapters: 400SH511

Water trap: 400SH130

We should choose the components according to the practical conditions.

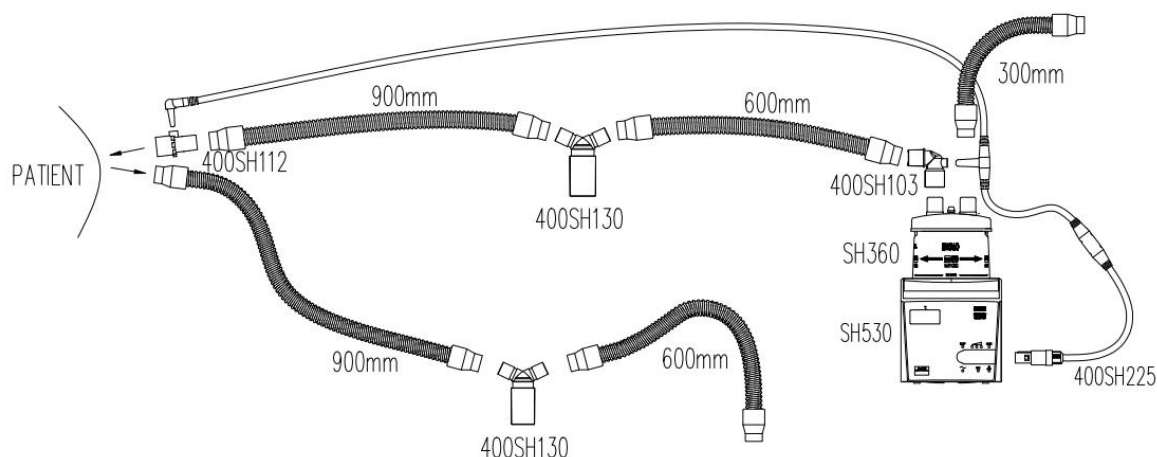

Fig. 6-3 the typical system (without heater wires)

Components in this system:

Humidification chamber: SH360

Respiratory tubes: silica gel tubes, the length is 600mm+900mm

Temperature probe: 400SH225

Adapters: 400SH112, 400SH103

Water trap: 400SH130

We should choose the components according to the practical conditions.

6.2 Basic operation steps

(1) Plug power cord of **SH530** humidifier into the required socket and the AC indicator light on.

(2) Check if power supply is connected.

(3) Check good protective earth continuity.

(4) Check right ventilation circuit.

(5) Check if the temperature probe is connected correctly. Check if the heater wire connector is connected correctly in heater wire mode.

(6) Start the ventilator and gas supply to set up a normal application airflow.

Warning: Ensure airflow flowing before connecting the machine with patient.

(7) Press down the working button of **SH530** humidifier then the “ON/OFF” indicator is lit. The humidifier enters self-checking state as follows:

(a) Display humidifier type, as “530”.

(b) Display software version, as “V2.0”.

(c) Judge that system is regular or not. Such as the temperature probe is inserted or not, or an abnormal alarm.

(d) Working mode selection: heater wire mode (mode indicator on)

Non-heater wire mode (mode indicator off)

Attention: when we pull out the heater wire assembly in heater-wire mode, the humidifier will switch to the non-heater wire mode, making a sound of 5 long warning tone (· · · · ·) , as a mode change warning.

Attention: the software updates all the time, you should contact manufacturer to update the software.

(e) Normally display the temperature at patient airway port.

(8) According to the actual parameters of ventilator, the ambient temperature and the patient port temperature digitally displayed on the panel, regulate the temperature setting button to set the optimal step.

Note: Ventilator-invasive mode, set the temperature at "high" step; non-invasive ventilation (masks) mode, set the temperature at “medium” step; family CPAP ventilator, set the temperature at "low" step.

Warning: We shall set the temperature at “low” step when warming up the humidifier. We shall increase the step after normal operation.

(9) Press down the temperature setting button. There are three steps, “low”, “medium” and “high”. We can set the temperature from low to high circularly. It needs 30min to stabilize the temperature after setting the temperature.

Setting steps and indicators,

Low setting	Left LED illuminated only	(● ○ ○)
Medium setting	Left and middle LED illuminated	(● ● ○)
High setting	All three LED illuminated	(● ● ●)

(10) When the patient port temperature exceeds 41°C, the alarm indicator light on and the audible alarm works at the same time. Press down the silence button at the same time. Wait for a moment (1~2min). If the alarm continues, the humidifier is out of control or damaged. Power off then replace the humidifier.

(11) **SH530** humidifier must be turned off when the airflow is interrupted or stopped.

Attention: Many operation factors may focus on breathing tubes.

Warning: Don't touch heater plate—the surface temperature may reach 85°C.

Warning: Periodically inspect the airflow temperature at patient port displayed on panel .

Warning: Periodically inspect water level in chamber to avoid it too high or too low.

Warning: We should clear the condensate water in water trap in time when in the non-invasive mode, or the condensate water may get into the breathing tubes and block the airway.

Note: The temperature of the breathing tube is below 41°C.

(12) Put the power off and disconnect the plug after working finished. Disconnect various connections carefully then make cleaning and sterilization of the whole equipment and accessories then use it directly next time.

Attention: Pour out the water in the humidification chamber then clean and dry it after use. Assembly and disassembly methods are shown in 8.6.

6.3 Overheating Protection

If the temperature of heater plate reached $120\pm 5^{\circ}\text{C}$ the overheating protection relay will cut off the power supply of **SH530** humidifier and the AC indicator is cut off also. After cooling the overheating protection relay and power supply shall be reset by hand. Refer to 8.4.1 for more details.

Warning: When the unconventionality appears (including out of control or damaged) the overheating protection will just appear. If it appeared when you are using, please contact with the local supplier or our customer service department directly.

7 Alarm

7.1 Alarms of Troubles

The device provides two alarm levels, high and medium priority.

· **High Priority**—these alarms require immediate operator response. The alarm signal consists of a high priority sound, which is a continuous three-beep and two-beep pattern (indicated in the following table as: ··· ··). Additionally, the error indicator will provide a high priority flashing pattern consisting of a red, continuous, bright-to-off, one-flashing pattern (indicated in the following table as: ◇ ◇ ◇). Meanwhile, the trouble codes are displayed in the display windows.

The trouble codes are E1, E2, E3, E4 showed in the displaying window. If there is more than one trouble, the window shows all the codes circularly until the troubles are cleared.

· **Medium Priority**—these alarms require promote operator response. The alarm signal consists of a medium priority sound, which is a continuous three-beep pattern (indicated in the following table as: ···). Additionally, the error indicator will provide a medium priority flashing pattern consisting of a yellow, continuous, bright-to-off, one-flashing pattern (indicated in the following table as: ◇ ◇ ◇).

Table 7-1 Alarm Summary Table

Alarm	Audible	Visual	Device Action	Possible Cause	Patient Action
Troubles of temperature sensors at patient port	··· ··	Visual indicator: ◇ ◇ ◇ Information in display window: E1	The relay stop working, the heater plate and heater-wire stop heating	Troubles of temperature sensors (short or open)	Press down the “silence” button, stop the audible alarm, change the sensor or contact the manufacturer.
Troubles of temperature sensors at chamber port	··· ··	Visual indicator: ◇ ◇ ◇ Information in display window: E2	The relay stop working, the heater plate and heater-wire stop heating	Troubles of temperature sensors (short or open)	Press down the “silence” button, stop the audible alarm, change the sensor or contact the manufacturer.

Troubles of temperature sensors of heater plate	••• • •	Visual indicator: ◇ ◇ ◇ Information in display window: E3	The relay stop working, the heater plate and heater-wire stop heating	Troubles of temperature sensors (short or open)	Press down the “silence” button, stop the audible alarm, change the sensor or contact the manufacturer.
Troubles of ambient temperature sensors	••• • •	Visual indicator: ◇ ◇ ◇ Information in display window: E4	The relay stop working, the heater plate and heater-wire stop heating	Troubles of temperature sensors (short or open)	Press down the “silence” button, stop the audible alarm, change the sensor or contact the manufacturer.
The temperature of patient port $\geq 41^{\circ}\text{C}$	••• • •	Visual indicator: ◇ ◇ ◇ Information in display window: the actual temperature	The relay stop working, the heater plate and heater-wire stop heating	The temperature above the protection range	Press down the “silence” button, stop the audible alarm, disconnect the tubes, observe the display window until the temperature return to normal. If it can not return, please contact the manufacturer.
Heater wire operation, high temperature step, low temperature alarm	•••	Visual indicator: ◇ ◇ ◇ Information in display window: the actual temperature	no	Temperature sensor of patient port is loose or the resistance of the sensor is not correct. Working environment does not meet the requirements.	Press down the “silence” button, stop the audible alarm, reinsert the temperature sensor or replace the sensor. Readjust the working environment to the recommended range.

Non-heater wire operation, high temperature step, low temperature alarm	...	Visual indicator: ◇ ◇ ◇ Information in display window: the actual temperature	no	Temperature sensor of patient port is loose or the resistance of the sensor is not correct. Working environment does not meet the requirements.	Press down the "silence" button, stop the audible alarm, reinsert the temperature sensor or replace the sensor. Readjust the working environment to the recommended range.
---	-----	---	----	---	--

Attention : In heater wire mode, the humidifier will appear five long warning tone (· · · · ·) when we pull out the heater wire assembly and it works in non-heater wire mode. The warning tone is not an alarm; it is just a prompt of mode change.

Attention : When humidifier appears troubles, the operator should deal with troubles in 2meters away from humidifier.

Note: There is 1 second delay between appearing troubles and bringing alarms.

Note: When humidifier is starting to operate, we test the alarm system by not inserting the sensors or unplugging the sensors.

Note: The setting value of humidifier alarm system has been set before leaving the factory. If operator or user wants to adjust or change it, please contact our company.

Note: When the sound pause button is pressed, the sound alarm signal of the humidifier is inactivated, and the alarm signal indicator remains unchanged. At the same time, the "silence" indicator is on. If the troubleshooting or high temperature state still exists, the alarm signal will be activated again after the sound alarm is suspended for 110s. At this time, the "silence" indicator will be extinguished and the sound alarm will ring again.

Note: The flicker frequency of the error indicator is 1.56 Hz.

7.2 Sound Pressure of Alarms

1 meter away from humidifier			
ALARM CONDITION ⁽¹⁾	Measured sound pressure level (dB)	A-weighted background level ⁽²⁾ (dB)	Remarks
E1	68.4	35.4	HIGH PRIORITY
E2	68.4	35.4	HIGH PRIORITY
E3	68.4	35.4	HIGH PRIORITY
E4	68.4	35.4	HIGH PRIORITY
$\cong 41^{\circ}\text{C}$	68.4	35.4	HIGH PRIORITY
MODE CHANGE	68.4	35.5	INFORMATION SIGNAL
LOW TEMPERATURE ALARM	68.4	35.4	MEDIUM PRIORITY
Supplementary information:			
(1) Including HIGH, MEDIUM and LOW PRIORITY ALARM CONDITIONS.			
(2) Including any INFORMATION SIGNAL or extraneous noise			

The sound pressure level: $<70\text{dBA}$, from 100HZ to 8KHZ

In simulate patient environment, “A-weighted background level” is measured in the normal operating condition. “Measured sound pressure level” is measured in the abnormal or mode changing conditions.

8 Servicing and Periodic Check

Attention: the contents of the whole parts are shown in appendix A, the complete exploded view is shown in Fig. A-1.

Warning: the following operation should only be done by service personnel or manufacturer

Warning: The machine is still energized when the working button is turned off. Be sure SH530 is isolated from the power supply before servicing.

Ensure all the screws are fixed tightly on both the inside and outside of humidifier after servicing finished and humidifier being assembled. The humidifier may be badly affected whenever anyone of the screws is loose.

Do not use excessive force when re-fastening screws, in order to avoid permanent damages such as units cracking.

Attention: Because the SH530 humidifier is complex, the electronic parts are especially complicated, if the PCB components are damaged, we recommend service personnel not to replace components on it. You should buy another one with the same type to replace it. Or you can send the humidifier to our service department for repair.

Warning: we will make available on request circuit diagrams, component part lists and other information that will assist SERVICE PERSONNEL to repair those parts of the device that are designated by the MANUFACTURER as repairable by SERVICE PERSONNEL.

Attention: the service personnel should be trained and written authorized by manufacturer.

Warning: Before service, pull out the mains plug from the main supply socket-outlet.

8.1 Open the shell and remove the PCB

8.1.1 Open the shell

- (1) Ensure the mains plug has been disconnected from the wall socket.
- (2) Put the humidifier upside down and remove the four screws out of the rear cover.
- (3) Separate the front cover of the shell from the rear cover carefully (See the whole exploded view in Fig. A-1).

8.1.2 Remove the PCB

- (1) Remove three screws fixed in PCB.
- (2) Pull out all the connectors connected to the PCB.
- (3) Remove the PCB carefully.

8.2 Replace the Fuses

Warning: Be sure to replace fuses with correct type and rating, specified in table 8-1.

- (1) Open the shell (See 8.1.1).
- (2) Remove the damaged fuse, replace a new one with the same type then assemble the whole shell.

Table 8-1 power and types of the replacing fuses

Model	Supply voltage	Fuse type	Part number
SH530	110VAC	F1 T 3A H 250V	004 021 106
		F2 T 3A H 250V	004 021 106
		F3 T 4A H 250V	004 021 108
	230VAC	F1 T 2A H 250V	004 021 104
		F2 T 2A H 250V	004 021 104
		F3 T 4A H 250V	004 021 108

8.3 Replace the PCB

Table 8-2 part number of PCB

Model	Supply voltage	PCB part number
SH530	110VAC	099 024 504
	230VAC	099 024 507

- (1) Open the shell.
- (2) Disconnect all cables and connecting lines of signal connectors on the PCB.
- (3) Unscrew the power cable, remove the wires.
- (4) Unpack the replaced PCB and replace it with the type given in Table 8-2.
- (5) Reconnect all the cables and connecting lines of connectors.
- (6) Install the new PCB and assemble the whole shell.

8.4 Service the heater plate

8.4.1 Reset the thermal cutout

Attention: The heater plate must cool sufficiently before resetting the thermal cutout.

- (1) Disconnect the power supply and open the shell.
- (2) Put the humidifier upside down, and find out the reset hole. Press the reset button by a screwdriver (See the whole exploded view in Fig. A-1, A-2).
- (3) Assemble the whole shell.

8.4.2 Replace the heater plate

Table 8-3 Part number of heater plate

Model	Supply voltage	Heater plate part number
SH530	110VAC	099 018 223
	230VAC	099 018 233

- (1) Open the shell and remove the PCB.
- (2) Unscrew the three fix screws on the heater plate (See the whole exploded view in Figure A-1, A-2).
- (3) Remove the heater plate out of front part of the shell, and be careful not to lose three springs underneath the heater plate.
- (4) Replace the heater plate. The type shall accord with Table 8-3.
- (5) Install the springs and screws, and also the new heater plate.
- (6) Assemble the PCB and the shell.

Attention: If the heater plate partly damaged, it is suggested to replace a complete one.

8.5 Replacing the mains cable

1. Open the case.
2. Disconnect the ribbon of mains cable on the PCB, open the dark green terminal, and take down the cables (two). Open the earthing screw on the bracket, and take down the earth wire. Open the white fixing piece of mains cable by screwdriver.
3. Take the mains cable away from the rear of the case.
4. Replace the mains cable; fix it on the bracket by fixing piece. Connect two of the cable to the terminal on PCB. Also connect the earthing cable to the earthing terminal on the bracket. Fix the cable on PCB by new ribbon.
5. Close the case.

Warning: washer shall be used when connecting earthing cable to the earthing terminal on the bracket.

Attention: the mains cable can not be replaced by users, it just be replaced by professional serviceman.

Warning: Replacing the mains cable by a new one which is supplied by the manufacturer.

Cord type	Phase	Neutral	Earth
European	Blue	Brown	Yellow green

8.6 Assemble and disassemble the humidification chamber & replace the parts

8.6.1. Disassemble the humidification chamber

(1) Turn off the SH530 Humidifier and unplug the inlet/outlet tubes connected with the humidification chamber.

(2) Press down the chamber guard. Move ahead the humidification chamber and remove it from the mainframe of **SH530** humidifier;

8.6.2. Disassemble and assemble the humidification cup

(1) Disassemble the coping from humidification cup by anticlockwise rotation.

(2) Apart the chamber base and humidification cup after holding them with

two hands respectively. Or use the small screwdriver to prise the humidification cup out lightly along the edge of the chamber base to make them apart.

(3) After cleaning and drying (if need sterilization, refer to section 9.3), press the humidification cup to make the chamber base to the right position.

(4) Assemble the coping with the humidification cup by clockwise rotation.

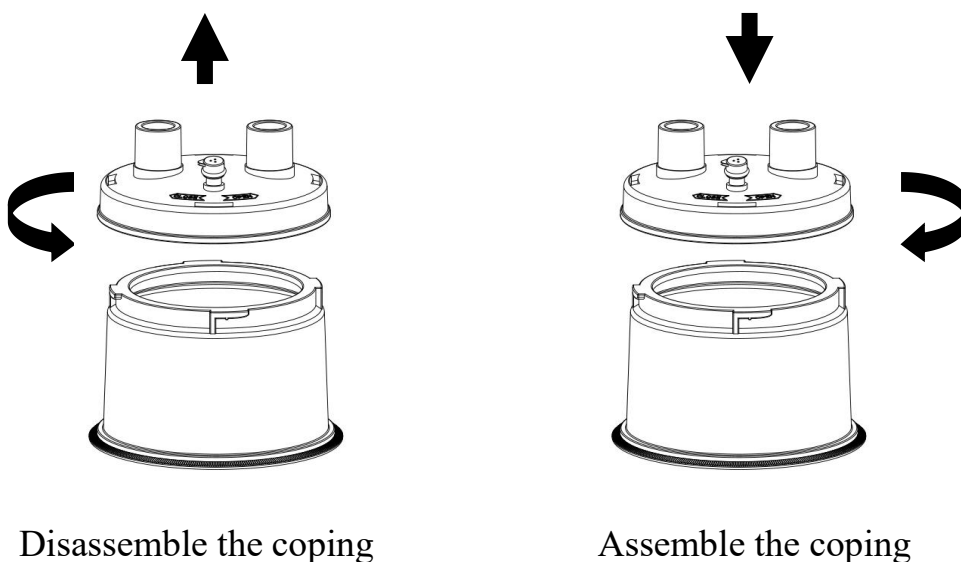

Fig.8-1

8.6.3. Replace the coping washer of the humidification cup.

(1) Disassemble the coping washer from the coping trough when replace the coping washer.

(2) Put a new one into the coping trough then press the coping washer evenly with hand.

8.6.4. Replace the O circle of chamber base

(1) Disassemble the O circle from the chamber base trough when replace the O circle.

(2) Put a new O circle into the chamber base trough then press the O circle evenly with hand.

8.7 Periodic Safety Checks

The following safety checks should be performed at least every 24 months by a qualified person who has adequate training, knowledge, and practical experience to perform these tests.

* Inspect the equipment and accessories for mechanical and functional

damage.

- * Inspect the safety relevant labels for legibility.
- * Inspect the fuse to verify compliance with rated current and breaking characteristics.
- * Verify that the device functions properly as described in the instructions for use.
- * Check protective earth reliability.
- * Test the protection earth resistance according IEC 60601-1: Limit 0.2 ohm.
- * Test the earth leakage current according IEC 60601-1: Limit: NC 500 uA, SFC 1000uA.
- * Test the patient leakage current according IEC 60601-1: Limit: 10 uA (dc), 100uA(ac) (BF).
- * Test the patient leakage current under single fault condition with mains voltage on the applied part according IEC 60601-1: Limit: 5 mA (BF).

The leakage current should never exceed the limit. The data should be recorded in an equipment log. If the device is not functioning properly or fails any of the above tests, the device has to be repaired.

8.8 Troubleshooting

When trouble occurs, take quick action referring to the table below. If there is any damage or the humidifier is suspected to be faulty as a result of checking, pull out plug from mains socket-outlet, attach an “unusable” or “repair request” label to the humidifier and contact manufacturer or his agent.

Symptom	Corrective Action	Section
The gas was not heated by the device when working button pushed and working indicator is on.	The heater-wire under the heater plate breaks, replace the heater-wire or heater plate.	8.4
The working indicator is not on, also the humidifier don't work when working button pushed.	Check the fuse, replace if necessary; Check the thermal cut-out tripped, reset by hand if necessary; Faulty PCB, replace.	8.2 8.4.1 8.3

9 Cleaning, Disinfection, Sterilization & Maintenance

9.1 The Cleaning of Shell

- 1、 Disconnect the system power supply.
- 2、 Add domestic cleanser into water. Dip cotton cloth into water. Clean the shell with the cloth.
- 3、 Dry the shell with dry cloth.

Attention: Don't use organic benzene, anther, benzene, trichloroethylene etc to clean the shell.

9.2 Cleaning of power cable

- 1、 Disconnect the power supply.
- 2、 Add domestic cleanser into water. Dip cotton cloth、 soft brush into water. Clean the cable with the brush and cloth.
- 3、 Dry the cable with dry cloth.

9.3 Cleaning and Disinfection of temperature probe

- 1、 Add domestic cleanser into water. Dip cotton cloth、 soft brush into water. Clean the temperature probe with the brush and cloth.
- 2、 Dry the temperature probe with dry cloth.
- 3、 Disinfect the temperature probe with medical alcohol (disinfectant).
- 4、 Dry the temperature probe with dry cloth.

Warning: Don't put the plug of probe line into water, or it will be soaked.

9.4 Cleaning and Sterilization of humidification chamber

- 1、 Take the chamber apart. Add domestic cleanser into water. Dip cotton cloth into water. Clean the parts of chamber with the cloth. (Assembling and disassembling methods of the chamber are shown in 8.6)
- 2、 Dry all the parts with dry cloth.
- 3、 Put all the parts into high-pressure sterilizing boiler (103.4KPa, 121°C, 15min), sterilizing with high-pressure and high-temperature.
- 4、 After the temperature drops, dry the chamber with dry cloth.

Attention: It is wrong to sterilize the accessories of SH530 humidifier when they are bounded together.

9.5 Cleaning and Sterilization of heater wires

- 1、 Add domestic cleanser into water. Dip cotton cloth into water. Clean the heater wires with the cloth.
- 2、 Dry the heater wires with dry cloth.
- 3、 Put the heater wires into high-pressure sterilizing boiler (103.4KPa, 121°C, 15min), sterilizing with high-pressure and high-temperature.
- 4、 After the temperature drops, dry the heater wires with dry cloth.

Note: All the parts of chamber and heater wires can only be sterilized for 100 times.

Attention: the tubes used with the humidifier should be cleaned and disinfected according to their manufacturers' requirements.

Attention: For different patients, we should clean, disinfect and sterilize the humidifier and its accessories before using it.

Attention: For a same patient, relevant parts(heater wires, humidification chambers and temperature probes) must be sterilized or disinfected twice a week.

Attention: For patients with special respiratory infections, we should clean, disinfect and sterilize the humidifier and its accessories immediately after use.

9.6 Maintenance

Inspect and maintain the equipment & accessories periodically. Ensure the heater plate and chamber base are free from surface contaminations and damages. Heater plate surface can be cleaned by the wet cloth and dried by soft cloth.

10 Environmental protection

The humidifiers are used with ventilators to warm and humidify airflow. It has a certain life just like other medical equipments. If a certain part is determined to be scrapped, it is necessary to make a risk control of environmental damages.

10.1 Humidification chamber

As the chamber directly connecting the patient's respiratory tract, it may be infected with special viruses, the waste or trash in the chamber optional discarding may pollute the environment. The users must carry on the normal cleaning and disinfecting, give it to qualified companies to deal with according to the hospital processes.

10.2 The main frame of humidifier

After normal cleaning and disinfecting, the users must refer the humidifier to qualified companies according to abandonment orders of electronic products and hospital processes.

Warning: dispose of the device must follow local directive.

11 Transportation & Storage

Transportation and Storage environment: temperature $-10^{\circ}\text{C}\sim 50^{\circ}\text{C}$, $\text{RH}\leq 93\%$, atmospheric pressure $50\text{kPa}\sim 106\text{kPa}$, no corrosive materials and good ventilation.

Prevent from impulsion, acute shake and moisture during transportation.

Attention: When storage conditions are not satisfied, it is necessary to keep the equipment in working environment more than 8 hours from storage status into working status.

Appendix A

A.1 The following tables are the parts number detailed list of replaceable parts of humidifier. The figure is the exploded views of humidifier.

Table A-1

NO.	Part number	name	NO.	Part number	name
1	001 005 005	Chamber guard	17	003 001 208	Screw
2	003 008 325	Guard spring	18	006 007 504/ 006 007 204	Sticker
3	003 006 305	Washer	19	003 002 616	Screw
4	003 001 208	Screw	20	004 001 202	Mains cord
5	003 011 420	Screw	21	003 003 625	Screw
6	099 026 001	Heater wire inner adapter	22	001 015 001	Outer bracket
7	099 016 002	Probe inner adapter	23	001 007 005	Rear case
8	003 002 412	Screw	24	003 001 413	Screw
9	001 010 001	Mains cord presser	25	003 001 208	Screw
10	003 002 408	Screw	26	001 008 003	Button group
11	003 005 403	Nut	27	001 008 005	Button bracket
12	004 023 002	Transformer	28	099 024 507/ 099 024 504	PCB assembly
13	003 005 605	Nut	29	001 006 005	Front case
14	003 007 411	Washer	30	003 008 510	Heater plate spring
15	002 004 003	Inner bracket	31	099 018 233/ 099 018 223	Heater plate assembly
16	003 002 450	Screw			

We will provide the circuit diagram and other data about servicing according to the user's requirements.

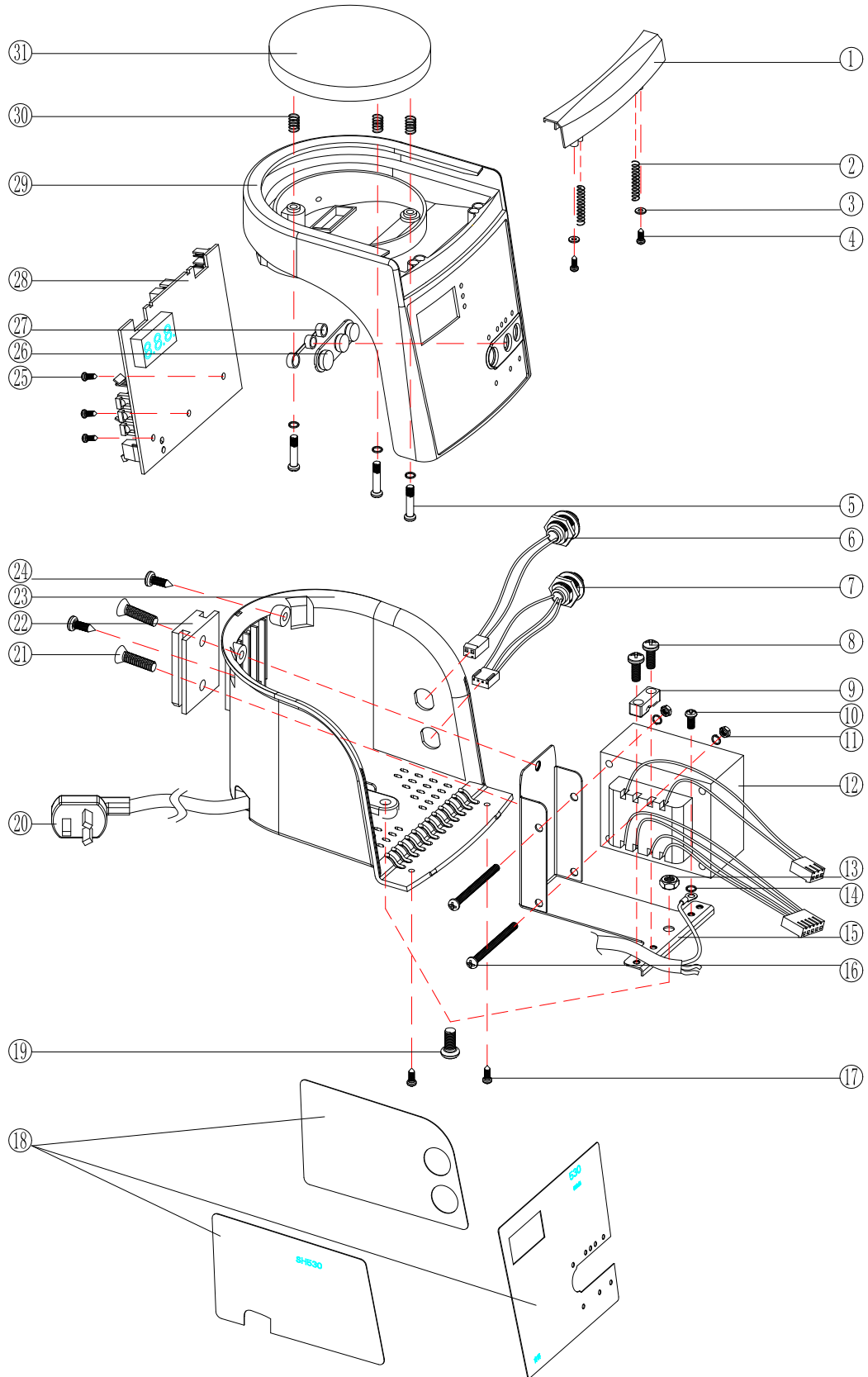

Fig. A-1 The humidifier's exploded view

A.2 The following tables are the parts number detailed list of heater plate. The figure is the exploded views of heater plate.

Table A-2

NO.	Part number	name	NO.	Part number	name
1	002 003 001	Heater plate	8	004 031 405	Emifil
2	004 005 002	Insulator	9	099 020 003	High temperature cord assembly
3	003 010 310	Tubular rivet	10	004 006 004	Thermal cutout
4	004 004 011/ 004 004 004	Heater wire	11	003 002 406	Screw
5	004 005 001	Insulator	12	003 007 411	Washer
6	002 006 001	Heater wire presser	13	099 017 003	Protective earth cord
7	003 002 408	Screw	14	004 022 002	Temperature probe of HP

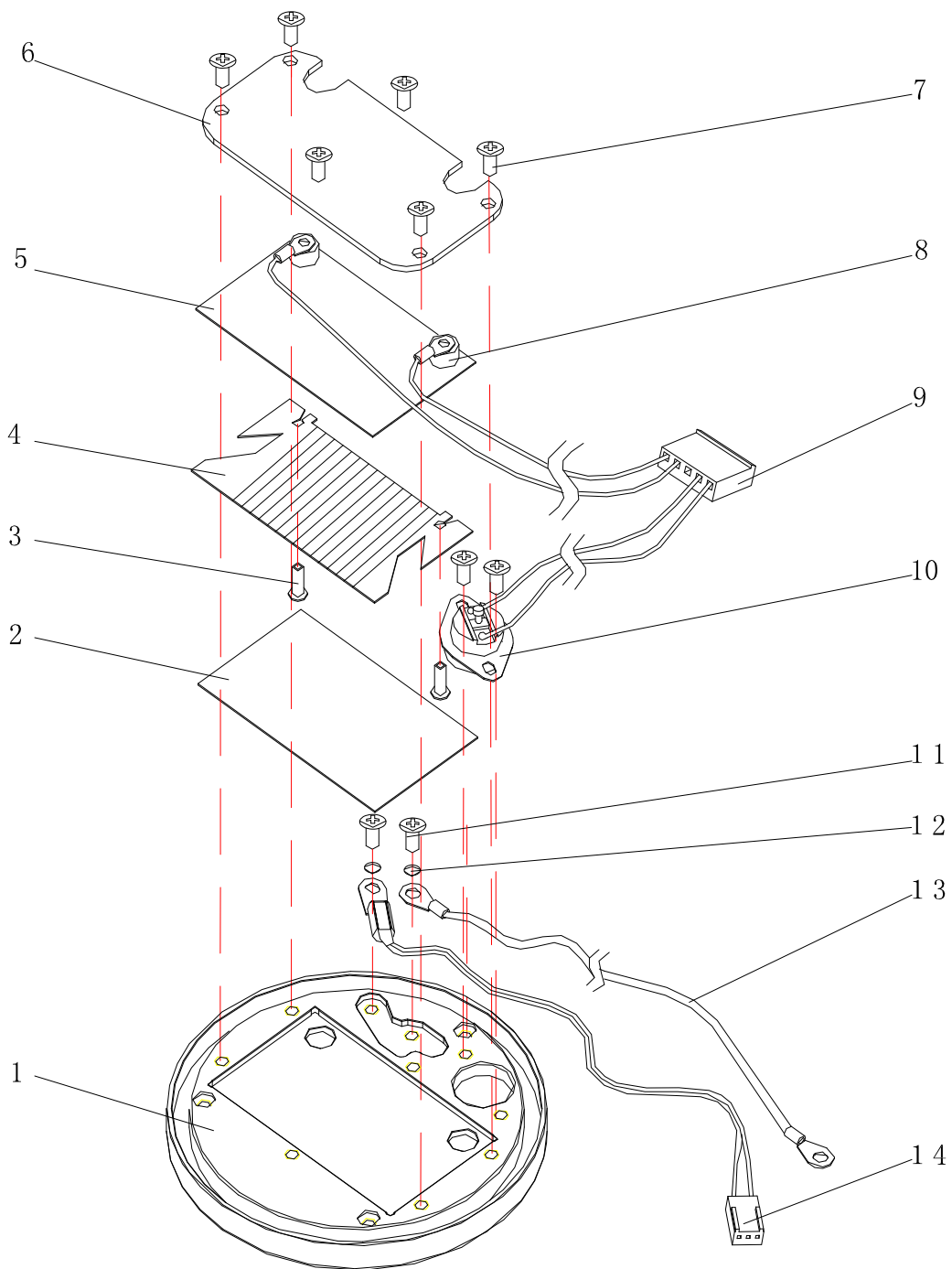

Fig.A-2 the heater plate's exploded view

Appendix B

EMC Information

Warning: The user shall install and use the humidifier according to the EMC information provided in the operating manual.

Warning: Ensure that the electromagnetic environment complies with the requirements of this appendix before use.

Warning: Use of this equipment adjacent to or stacked with other equipment should be avoided because it could result in improper operation. If such use is necessary, this equipment and the other equipment should be observed to verify that they are operating normally.

Warning: The portable RF communications equipment, including antennas, can affect humidifier, so the portable RF communications equipment should be used no closer than 30 cm (12 inches) to any part of the respiratory humidifier, including cables specified by the manufacturer.

Warning: The Operator should not use the system and should inform the customer service, if the ESSENTIAL PERFORMANCE is lost or degraded due to EM DISTURBANCES.

Warning: The system can operate correctly under the anti-interference level identified in this specification. If the interference level is higher than that level, it may cause functional degradation. Please take care to avoid functional degradation caused by high intensity electric field.

Information of the accessories, transducers and cables

Port No.	Name	Specification Type	Cable Length	Cable Shielded	Manufacturer
1	Temperature probe	400SH223 400SH225 400SH228 400SH233 400SH235 400SH238	1.3-1.8m	Shielded	Wuxi Jike Electronics Co., Ltd
2	Heater-wire adapter	400SH511 400SH512 400SH521 400SH522 400SH561	< 1m	Unshielded	

3	Heater-wire	400SH412 400SH413 400SH415	1.1-1.8m	Unshielded
---	-------------	----------------------------------	----------	------------

Warning: Use of accessories, transducers and cables other than those specified or provided by the manufacturer of this equipment could result in increased electromagnetic emissions or decreased electromagnetic immunity of this equipment and result in improper operation.

Table 1 Electromagnetic emission level

Electromagnetic emission	
Electromagnetic requirements of this RF generator are given below and it is the responsibility of end user to meet these requirements.	
Emission test	Compliance
CISPR 11 Conducted emission	Group 1, Class B
CISPR 11 Radiated emission	
IEC61000-3-2 Harmonic emission	Class A
IEC61000-3-3 Voltage fluctuation / flickering emission	Conform

Table 2 ENCLOSURE PORT

Phenomenon	Basic EMC standard	Immunity compliant levels
ELECTROSTATIC DISCHARGE	IEC 61000-4-2	± 8 kV contact ± 2 kV, ± 4 kV, ± 8 kV, ± 15 kV air
Radiated RF EM fields	IEC 61000-4-3	3 V/m 80 MHz – 2,7 GHz 80 % AM at 1 kHz
Proximity fields from RF wireless communications equipment	IEC 61000-4-3	See Table 4
RATED power frequency magnetic fields	IEC 61000-4-8	30 A/m 50 Hz or 60 Hz

Table 3 Input a.c. power PORT

Phenomenon	Basic EMC standard	Immunity compliant levels
Electrical fast transients / bursts	IEC 61000-4-4	± 2 kV 100 kHz repetition frequency
Surges Line-to-line	IEC 61000-4-5	$\pm 0,5$ kV, ± 1 kV
Surges Line-to-ground	IEC 61000-4-5	$\pm 0,5$ kV, ± 1 kV, ± 2 kV
Conducted disturbances induced by RF fields	IEC 61000-4-6	3 V 0,15 MHz – 80 MHz 6 V in ISM bands between 0,15 MHz and 80 MHz 80 % AM at 1 kHz
Voltage dips	IEC 61000-4-11	0 % UT; 0,5 cycle At 0°, 45°, 90°, 135°, 180°, 225°, 270° and 315°
		0 % UT; 1 cycle and 70 % UT; 25/30 cycles Single phase: at 0°
Voltage interruptions	IEC 61000-4-11	0 % UT; 250/300 cycle

Table 4 Test specifications for ENCLOSURE PORT IMMUNITY to RF wireless communications equipment

Test Frequency (MHz)	Band (MHz)	Service	Modulation	IMMUNITY TEST LEVEL (V/m)
385	380 – 390	TETRA 400	Pulse modulation 18 Hz	27
450	430 – 470	GMRS 460, FRS 460	FM ± 5 kHz deviation 1 kHz sine	28
710	704 – 787	LTE Band 13,17	Pulse modulation 217 Hz	9
745				
780				
810	800 – 960	GSM 800/900, TETRA 800, iDEN 820, CDMA 850, LTE Band 5	Pulse modulation 18 Hz	28
870				
930				
1720	1700 – 1990	GSM 1800;	Pulse modulation	28

1845		CDMA 1900; GSM 1900; DECT;	217 Hz	
1970		LTE Band 1, 3,4, 25; UMTS		
2450	2400 – 2570	Bluetooth, WLAN, 802.11 b/g/n, RFID 2450, LTE Band 7	Pulse modulation 217 Hz	28
5240	5100 – 5800	WLAN 802.11a/n	Pulse modulation 217 Hz	9
5500				
5785				