

EFFICIENT LINE

# SUPER SILENT



Contact

# Super, without the noise

The **SUPER SILENT** model stands out for its outstanding noise reduction. Easy to use, it features a high monitoring capability through control systems that track compressor operations. Standard equipment includes: two connections for high pressure hoses, interstage pressure gauge, oil level and internal cabin temperature control, rotation detector, electric motor, automatic condensate drain and autostop. Choose the best pumping group for your needs.

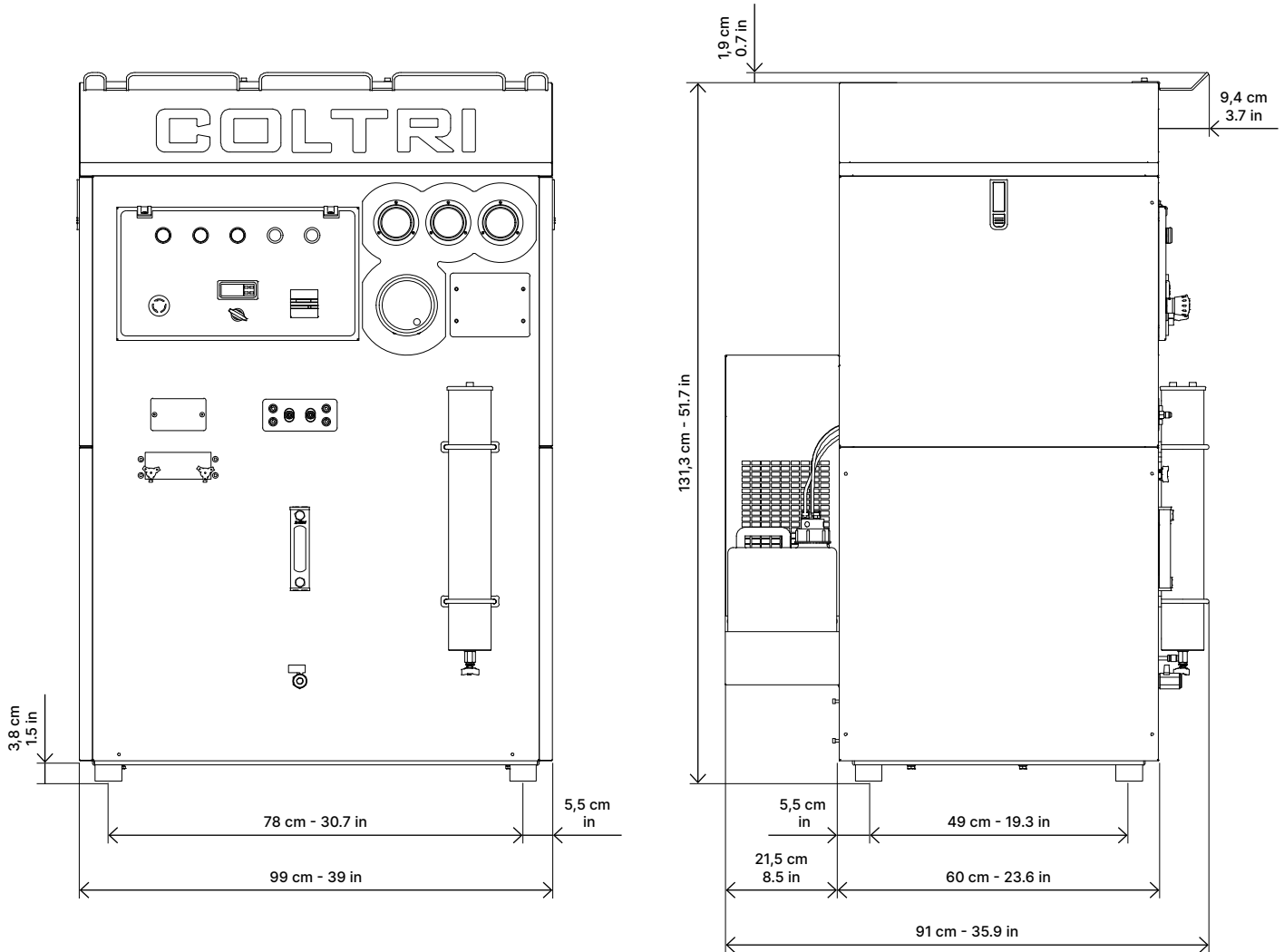

## Technical data

Type of gas	Breathing air EN 12021
Intake pressure	Atmospheric / max 300 millibar
Working pressure	232 bar / 300 bar / 330 bar
Max working pressure	420 bar
Permissible ambient temperature range	-10° C ÷ +40° C
Permissible altitude	0 ÷ 1.500 m SLM
Max permissible tilt	6°
Oil	Synthetic Coltri Oil ST 755
Oil change interval	1 year / 1.000 h
Frame	Steel - Colour Black RAL 9005 - Powder coating painting - Scratch proof

## Compressor

	235 ET	315 ET
<b>Charging rate</b> Measured during 10 liters cylinder filling from 0-200 bar tolerance +/- 5% at + 20 ° C ambient temperature.	235 l/min 14.1 m³/h 8.3 cfm	315 l/min 18.9 m³/h 11.1 cfm
<b>Purification System</b>	Maxifilter	
<b>Cooling air flow</b>	1,440 m³/h	2.180 m³/h
<b>Weight<sup>1</sup></b>	162 kg - 357 lb	168 kg - 370 lb
<b>Dimensions (W x D x H)<sup>1</sup></b>	90 × 91 × 132 cm - 35.4 × 35.8 × 52 in	
<b>Noise</b>	LpA 63,3 dB	

<sup>1</sup> Standard model. Dimensions and weight may vary depending on accessories.

## Electric motor

	235 ET		315 ET	
<b>Type</b>	Three-phase electric			
<b>Power</b>	4 kW - 5.5 Hp		5,5 kW - 7.5 Hp	
<b>Operating voltage/frequency</b> Different voltage / frequency available on request.	400 V, 50 Hz	440 V, 60 Hz	400 V, 50 Hz	440 V, 60 Hz
<b>Rated current</b>	9,7 A		12,6 A	
<b>Speed (RPM)</b>	2.840	3.410	2.850	3.420
<b>Protection class</b>	IP55			

The IP55 protection class, compliant with IEC 60034-5, guarantees protection against dust deposits and water jets from any direction.

# Technical data pumping unit MCH 16

	235 ET	315 ET
<b>Charging rate</b> Measured during 10 liters cylinder filling from 0-200 bar tolerance +/- 5% at + 20 ° C ambient temperature.	235 l/min 14.1 m <sup>3</sup> /h 8.3 cfm	315 l/min 18.9 m <sup>3</sup> /h 11.1 cfm
<b>Speed (RPM)</b>	1.270	1.600
<b>Number of stages</b>	3	
<b>Number of cylinders</b>	3	
<b>Cylinder bore 1st stage</b>	95 mm	
<b>Cylinder bore 2nd stage</b>	38 mm	
<b>Cylinder bore 3rd stage</b>	14 mm	
<b>Stroke</b>	40 mm	
<b>Direction of rotation (from flywheel side)</b>	Counter clockwise (left)	
<b>Drive type</b>	V-belt A type	
<b>Intermediate pressure 1st stage</b>	~ 6 bar	
<b>Intermediate pressure 2nd stage</b>	~ 45 bar	
<b>Oil sump capacity</b>	1,8 liters	
<b>Max intake pressure</b>	1,3 bar (absolute) / 300 millibar - 4,35 psi	

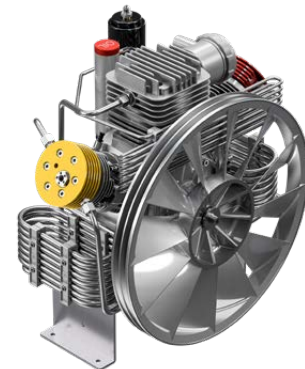
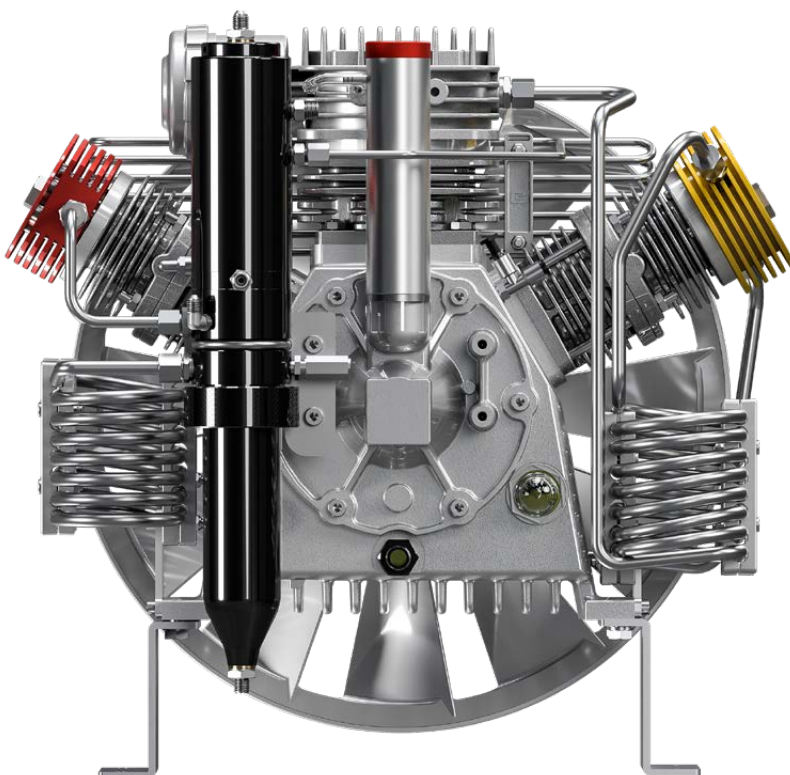



Splash lubrication with conrod pin immersed in oil



Suction filter: 10 µm

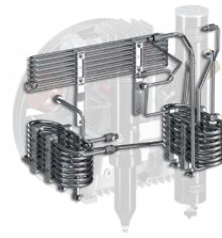

Pipes, fitting and nuts in stainless steel AISI 316

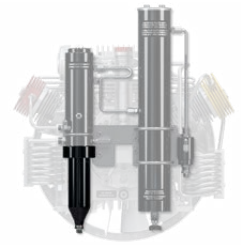

Intermediate condensate separator after the second stage

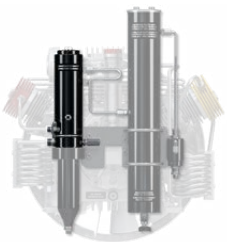

High pressure final condensate separator



Safety valves after each stage of compression



Die-cast aluminium cylinders with barrel coating in nicasil



Forged aluminum connecting rods



Forged steel crankshaft

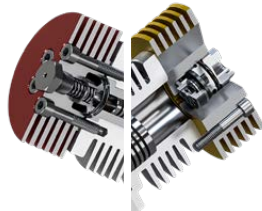

Stainless steel second and third stage valves



Roller Bearings for intensive work load

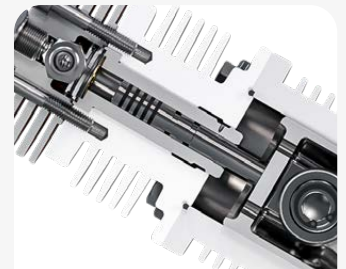

Third stage in tempered steel with 5 piston rings in special cast iron



Second and third stage with pushing pistons to eliminate lateral forces on the pistons

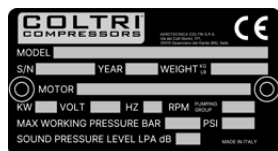

CE certification

# Standard equipment

## Purification system Maxifilter

MAXIFILTER cartridge repackable or disposable



Purification system	Maxifilter
Operating pressure (Standard)	250 bar / 330 bar / 360 bar
Operating pressure max. (PS)	420 bar
Processable air capacity (air inlet temperature in the filter 20° C at 300 bar) <sup>1</sup>	890 m <sup>3</sup>

<sup>1</sup> When using a filter cartridge without HOPCALITE CO CATALYST. If a cartridge with CO removal is used, the process air capacity is reduced by about 20%.

## Condensate separation system

- Interstage separator after 2nd stage
- Final separator for the removal of oil/water condensate
- Final safety valve, fitted to separator housing
- Pressure maintaining/non return valve



Contamination	Maximum content as per DIN EN 12021:2014	Air quality*
H <sub>2</sub> O	25 mg/m	≤ 10 mg/m
CO	5 ppm(v)	≤ 4
CO <sub>2</sub>	500 ppm(v)	≤ 500
Oil	0,5 mg/m	≤ 0,5 mg/m

- \* Measured at our facility using ASCO HORA 160 ANALYZER.
- Only with special filter cartridge with HOPCALITE CO CATALYST. and up to a maximum concentration of 25 ppm CO in intake air. The compressed clean breathing air then contains a maximum of 5 ppm CO.
  - The level of CO<sub>2</sub> in the intake air must not exceed the maximum level of CO<sub>2</sub> as per EN 12021:2014.
  - Reported values exceed standards:
    - ISO 8573-1 class 3 for particles
    - ISO 8573-1 class 1 for humidity
    - ISO 8573-1 class 1 for oil.



**Filling connection**

2 Filling connection to choose from: DRV DIN 232 bar, INT/YOKE DRV 232 bar and DRV DIN 300 bar.



**Electromechanical pressure switch**



**Interstage pressure gauges**



**Compressor control and automatic condensate drain system**



**Soundproof frame**

**Optional**



**C-Monitor**



**Multi-Gas Analysis System (SAM)**



**CO SafeGuard**

# Application fields

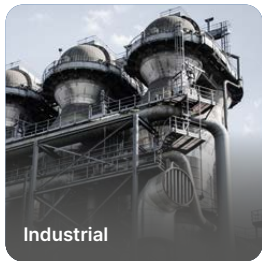
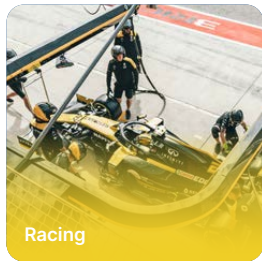
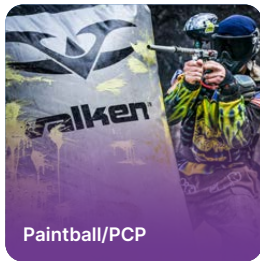

## Aerotecnica Coltri S.p.A.

Via dei Colli Storici, 177  
25015 Desenzano del Garda - Brescia - Italy

Tel. +39 030 9910301  
+39 030 9910297

[info@coltri.com](mailto:info@coltri.com)



Printed on paper from  
sustainably managed forests



[coltri.com](http://coltri.com)



Visit our  
showroom in  
Virtual Reality



[coltri.com/showroom](http://coltri.com/showroom)

**COLTRI**<sup>®</sup>  
COMPRESSORS