

# Flow Sensor SpiroQuant H

## Use the advantages:

- Proven passive flow differential pressure converter
- Measuring of breathing gas flow in adult applications
- High product quality
- RoHS conform
- Biocompatible components
- Short delivery times
- Technical support
- Made in Germany
- Certified quality management system according EN ISO 13485



## „We keep your devices operating at their best.“

EnviteC has been developing and manufacturing highly specialized products for medical applications. EnviteC's research and development activities are consistently aligned to customer and market needs – identification and optimization of sustainable product solutions are the main concerns of the company.

The company trusts in the quality of advanced production methods and processes. The result are flow measurement solutions for medical applications, which share the same extraordinary quality, excellent signal stability and reliable response for accurate readings. The Flow sensor SpiroQuant H is a passive flow differential pressure converter for measuring of breathing gas flow in connection with the appropriate measuring unit (differential pressure gauge). The sensor is designed as disposable sensor for single patient use in adult applications. A re-use or cleaning is not allowed.

## From standard sensors to customized sensors

Experienced EnviteC engineers analyze customer requirements. This input is used for different standard and OEM applications, and ongoing support is provided right up to the final integration in the solution. EnviteC designs customized sensors characterized by a maximum possible degree of precision.

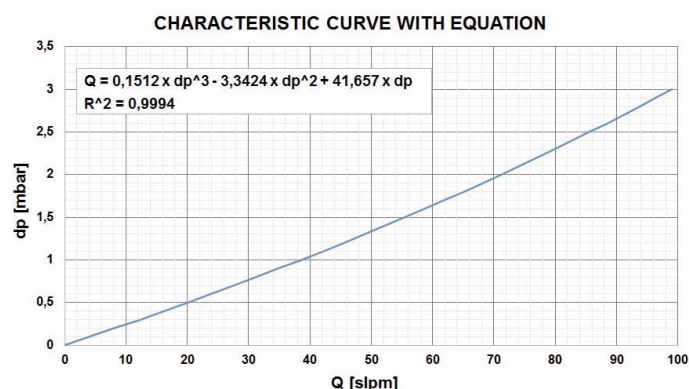

## Mechanical drawing (All dimension in mm)

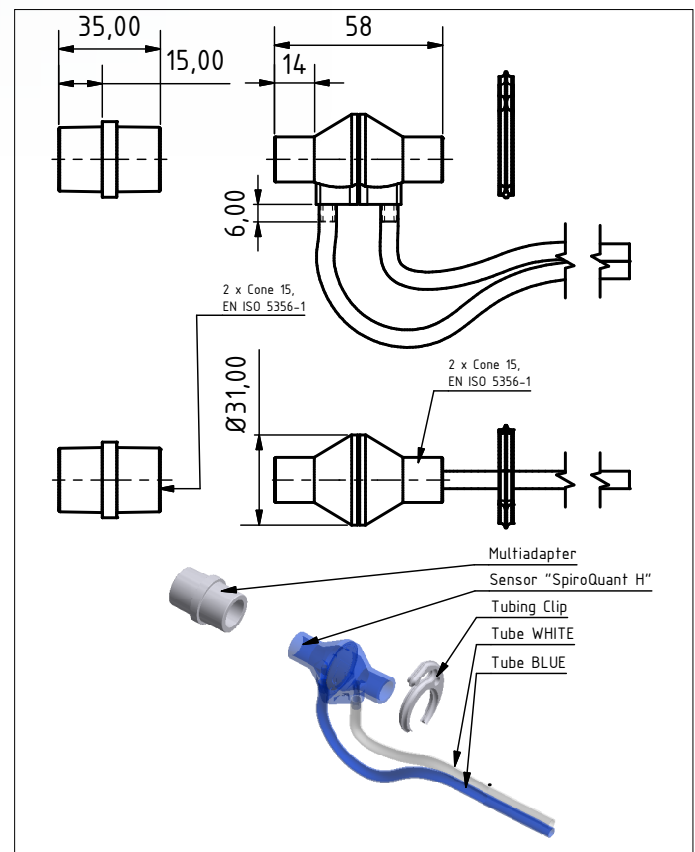

General tolerances ISO 2768-c

## Additional information

If the sensor is intended to replace the original flow-sensing component in anesthesia machines or ventilators, consult the EnviteC XRL Cross Reference List under [www.EnviteC.com](http://www.EnviteC.com) for selecting the appropriate sensor.

## For more information please contact us!

**We look forward to assisting you either on the phone or in a personal talk.**

## Technical Specifications SpiroQuant H

|                          |  |
|--------------------------|--|
| Measuring principle      | Differential pressure principle  |
| Cross reference          | Compatible to Hamilton flow sensor PN 279331   |
| Sensor type              | Disposable sensor for single patient use   |
| Application              | Adult applications   |
| Flow range               | 0 ... 100 slpm (standard liters per minute)  |
| Accuracy                 | ± 15 % over measuring range  |
| Flow resistance          | Approx. 1.0 mbar equals 60 slpm  |
| Operating temperature    | 0 °C ... +50 °C  |
| Operating humidity       | 5 ... 95 % RH non-condensing   |
| Operating conditions     | 570 ... 1200 hPa only with external pressure compensation  |
| Operating time           | Single patient use, applicable as long as a sensor calibration is successful   |
| Storage temperature      | -20 °C ... +70 °C  |
| Storage ambient pressure | 570 ... 1200 hPa   |
| Storage humidity         | 5 % ... 95 % RH non-condensing   |
| Storage time             | Max. 5 years   |
| Dead space               | 11 cm <sup>3</sup> (without cone adaption)   |
| Cleaning / disinfection  | No re-use, cleaning or disfection not allowed  |
| Weight                   | Sensor without tubes: approx. 11 g;<br>Sensor incl. tubes: approx. 51 g  |
| Material                 | Housing parts: MABS;<br>Inner part: PET;<br>Tube: PVC - medical grade;<br>Tube length: 1.8 m;<br>Tube diameters: dI 0 3.0 mm -0.1 +0.05; dA = 4.6 mm |
| Part number              | 07-00-0001: SpiroQuant H (Pack with 6 pieces incl. clip and adapter);<br>07-000027: Tubing clip;<br>07-000025: Multi adapter                         |

All specifications are applicable at standard conditions:  
1013 hPa, 25 °C dry ambient air



### Certified Quality Management

EnviteC is maintaining a quality management system, which meets the requirements of EN ISO 13485 for medical devices.

### EnviteC-Wismar GmbH a Honeywell Company

Alter Holzhafen 18, 23966 Wismar, Germany

Phone: +49 (0)3841-360-1

Phone: +49 (0)3841-360-200

Fax: +49 (0)3841-360-222

Internet: [www.envitec.com](http://www.envitec.com)

Email: [info@envitec.com](mailto:info@envitec.com)

Doc. No. 007-05-SpiroQuant\_H\_Spec-0

December 2017

Technical information is subject  
to change without notice!

© 2017 Honeywell International Inc.

EnviteC by Honeywell reserves the  
right to make changes in product  
specifications and adjust its production  
at any time and without notice.

**ENVITEC**  
by Honeywell