

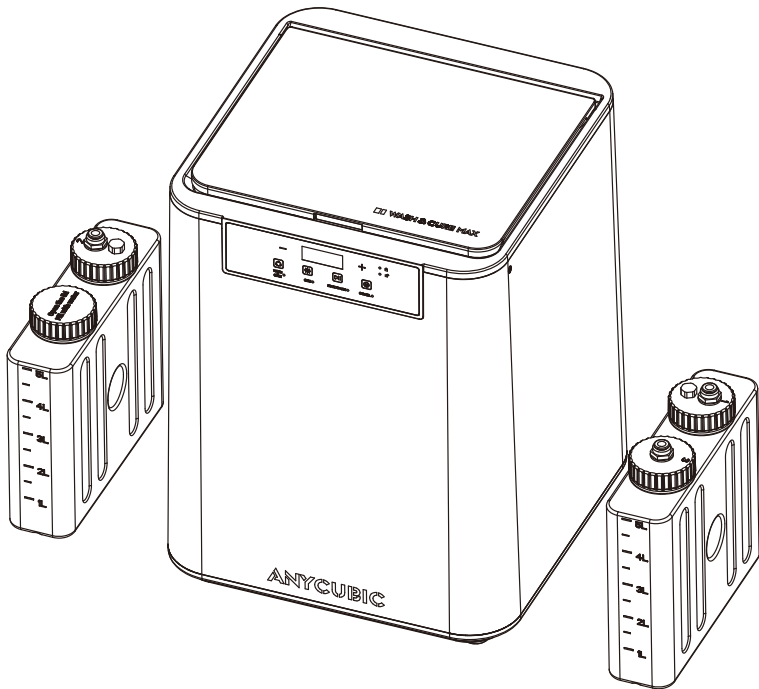

Wash & Cure Max

Installation and Usage Instructions



All pictures are for reference only. Please refer to the actual object.

Dear customer,

Thank you for choosing Anycubic products.

Please read this instruction carefully. The installation techniques and precautions in the instruction can help you avoid any unnecessary damage or frustration.











Please visit <https://support.anycubic.com> to contact us if you have any questions. You can also learn more information from the website, such as software, videos and models.



Anycubic support center

Safety Instructions

Always follow the safety instructions during assembly and usage, to avoid unnecessary damage to the machine or individual injury.

-  Please contact our Customer Service if you have any issues after receiving the products.
-  Do not force to open the door when the machine is working to avoid the individual injury or environmental damage.
-  **Open flames are prohibited. Please keep the machine away from fire and heat to prevent a fire or explosion.**
-  In case of emergency, please immediately cut off the power of the machine and contact our technical support.
-  The pipes must be connected properly. Do not frequently plug and unplug the pipe, as the joints may become loose and cause water leakage and other problems.
-  Keep the machine and its accessories out of the reach of children.
-  **Do not clean or cure the models directly without the tray.**
-  The washing solvent should be sealed and stored in a cool and dry place after use. If the solvent is alcohol, please comply with usage specifications of alcohol.
-  Do not expose the machine to any water or rain environment.
-  Use the machine in an environment with a temperature of 10°C-40°C and a humidity of 20%-90%. For optimal performance, do not exceed this range.
-  Do not disassemble the machine, please contact the technical support if you have any questions.

Content

01 Introduction 1

02 Preparations 3

03 Control Panel 6

04 Usage Instruction 7

Wash & Cure Mode 8

Cure Mode 10

05 Maintenance 12

06 Troubleshooting 16

01 Introduction

Overview

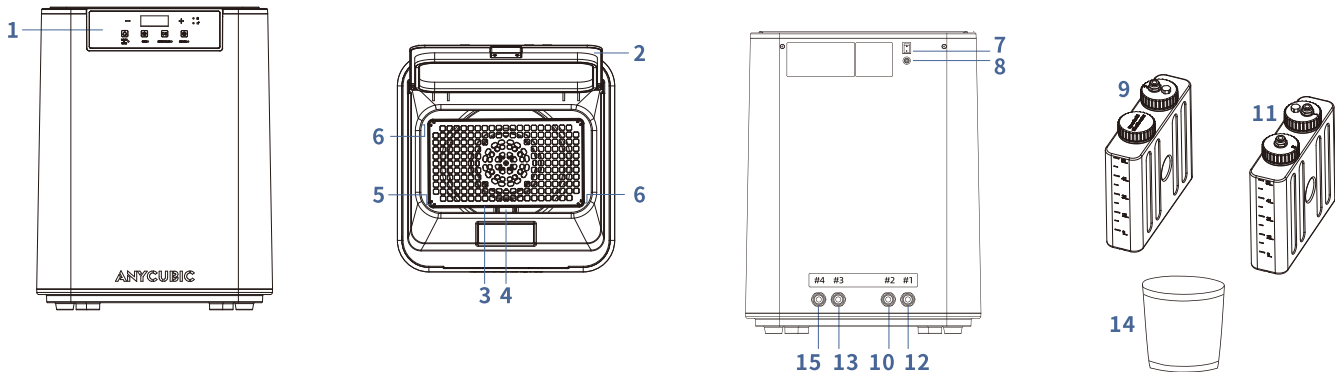

- 1. Control Panel:** Set the working mode and time
- 2. Door:** To block the detergent spray and UV light
- 3. Tray:** Load the printed objects during washing and curing
- 4. Strainer:** To filter the residue
- 5. UV Light:** To cure the printed objects
- 6. Sprinkler:** To spray the detergent /water
- 7. Power Switch**
- 8. Power Port**

- 9. Water Container:** To load the water
- 10. Water Inlet:** To connect the pipe 2
- 11. Detergent Container:** To load detergent
- 12. Detergent Inlet:** To connect the pipe 1
- 13. Detergent Outlet:** To connect the pipe 3
- 14. Bucket:** To collect the waste
- 15. Waste Output:** To connect the pipe 4

In the Box

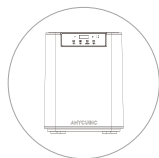

Wash & Cure Max

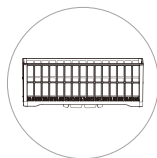

Tray*1

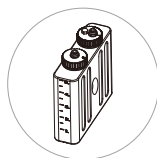

Detergent container*1

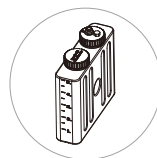

Water container*1

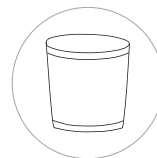

Bucket*1

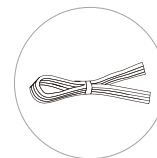

Tube*4



Hex Key Set



Plastic scraper

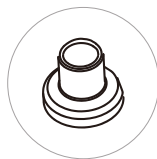

Filter replacement for container

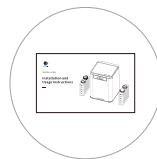

User Manual*1

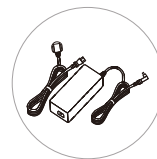

Power Cord
Power Adaptor

Product Parameters

Technical Specifications

Properties	Wash and Cure
Control method	Control Panel
Rated Power	144W
Input Voltage	AC110-240V 50/60Hz
UV wavelength	405nm

Physical Dimensions

Product Dimension	434 mm(L) *434 mm(W) *556 mm (H)
Washing/ Curing Volume	300 mm(L) *165 mm(W) *300 mm(H)
Weight	13.5kg

02 Preparations

For the first use, please follow the instruction to finish the preparation. The machine has been carefully examined; few water marks or droplets might appear. This phenomenon does not affect the normal use of the device.

1. Take out the accessories in the machine.
2. Connect the pipes.

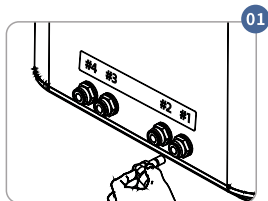

Insert the pipe and then check whether it is loose

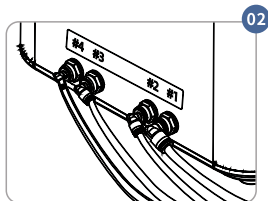

Insert the pipes to the corresponding ports

**Notice: To unplug the pipes, please refer to the steps in page 15.
Force to pull the pipe will damage the safety valve to affect the sealing of the pipes.**

3. Prepare the detergent container. If the pipes are too long, please cut them to proper length.

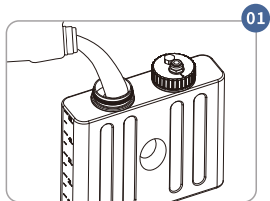

Pour more than 4L detergent* into the container

*This product allows IPA or ethanol($\geq 95\%$) as detergent.

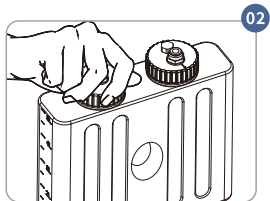

Tighten the lid

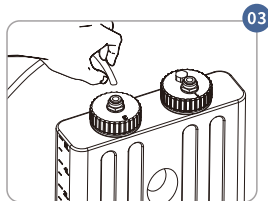

Insert the pipes to the lids with the same numbers

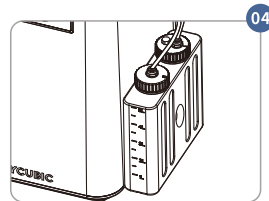

Put the container against the machine to avoid it tip over

4. Prepare the water container. If the pipe is too long, please cut it to proper length.

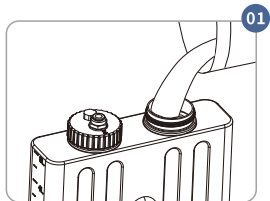

Fill the container with water

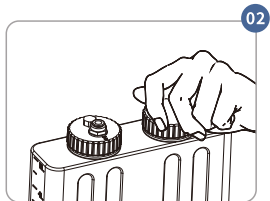

Tighten the lid

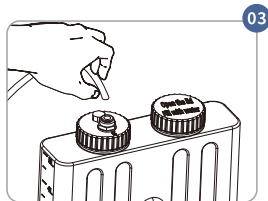

Insert the pipes to the lids with the same numbers

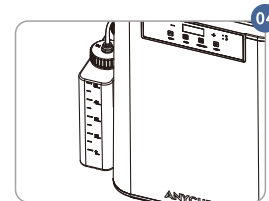

Put the container against the machine to avoid it tip over

5. Put the pipe 4 into the bucket

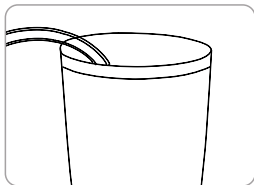

**Do not pour waste liquid or partially cured resin into drains.
Please collect the waste with the bucket and then dispose
the wastes. The disposal of used solvent is in the page 12.**

6. Install the tray.

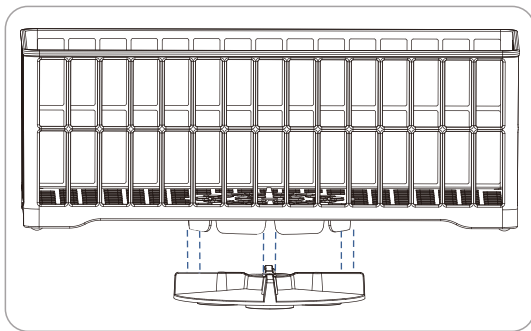

Align the groove with the rotor

03 Control Panel

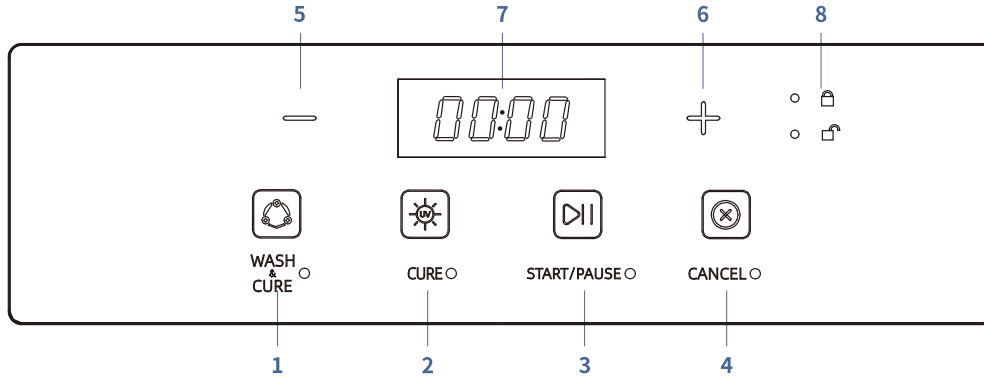

- 1. Wash & Cure Mode:** The work flow costs 15' 30".
- 2. Cure Mode:** The work flow costs 3 minutes by default setting.
- 3. Start/Pause:** To start or pause the process.
- 4. Cancel:** When the machine is working, press it once to stop*. When machine is free, long press it for 3 seconds to drain off the liquid in the machine.

- 5. Reduce time:** Press once to reduce one minute and long press to reduce time continually.
- 6. Add time:** Press once to add one minute and long press to add time continually.
- 7. Remaining Time:** The remaining time of the process.
- 8. Lock Status:** To display whether the door is locked. The red light indicates that it is locked and the green light indicates that it is unlocked.

***If you stop the washing process, the machine will drain off the liquid which takes up to 4' 30". The control panel is invalid before the machine finishes the reset.**

04 Usage Instruction

This machine is suitable for washing and post-curing the printed objects of 3D resin printers. This machine has two working modes. The following parts illustrate its basic operation and precautions in different working modes. Please read it carefully before use.

1. Plug in power and turn on the machine.

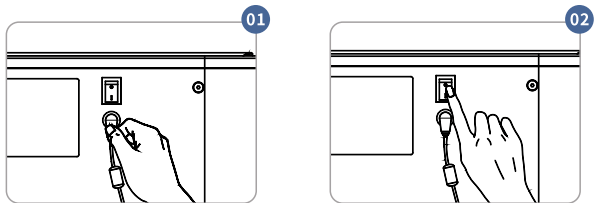

2. Check whether the detergent/water container is filled up.

Wash & Cure Mode

This one-key operation can help you to finish both washing and curing. The working time of this mode cannot be modified.

1. Place the objects in the tray after removing them from the print platform.

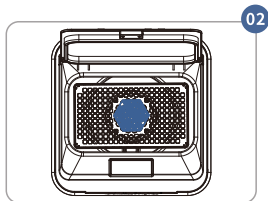
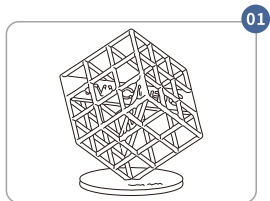

Place the printed objects in the tray

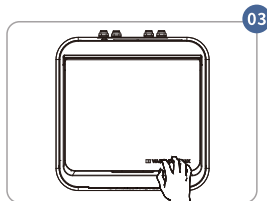

Close the door

2. Press WASH&CURE button to select this mode. Then, press START/PAUSE button to start the washing and curing process. The door is locked when the machine is working.

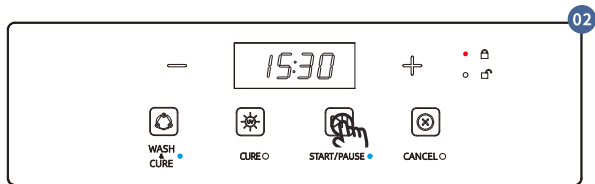
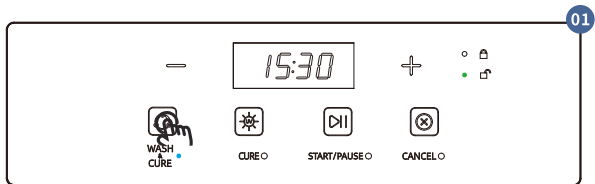

3. If you have to open the door during washing, the process must be stopped. Press CANCEL button and wait for it finishes the current program. Then, open the door.

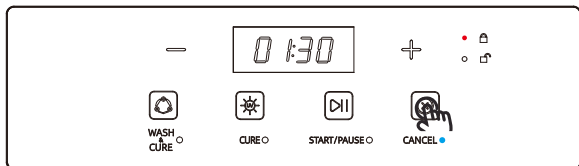

Stop the process

4. If you have to open the door during curing, press START/PAUSE button to pause the process and open the door when the indicator light is green. Then, press START/PAUSE button to continue the process.

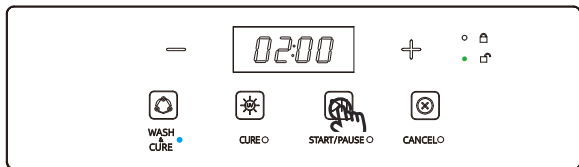

Pause/start the process

5. A beeping sound indicates the process is finished. Please open the door and take out the printed objects.

Cure Mode

This operation only cure the printed objects.

1. Place the objects in the tray.

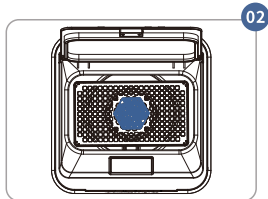
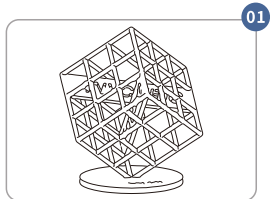

Place the printed objects in the tray

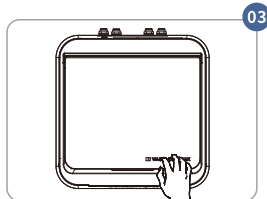

Close the door

2. Press CURE button to select this mode. You can modify the curing time by pressing +/- button. Then, press START/PAUSE button to start the curing process. The door is locked when the machine is working.

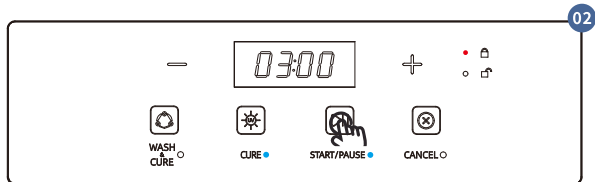
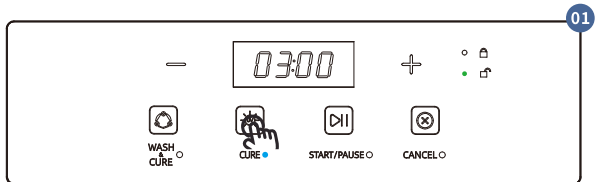

3. If you have to open the door during curing, press START/PAUSE button to pause the process and open the door when the indicator light is green. Then, press START/PAUSE button to continue the process.

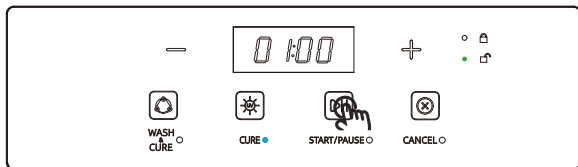

Pause/start the process

4. A beeping sound indicates the process is finished. Please open the door and take out the printed objects.

05 Maintenance

Wastes Disposal

The waste liquid is the combination of water, a little resin and little detergent. It should be disposed of before being discarded.

- 1. Allow the solvent stay still for over 10 hours so the residue could be precipitated and settled.**
- 2. Pour the top layer of liquid into drainer and then expose the residue in the sunlight. Then, the cured resin can be handled as general solid waste.**

Recycling of detergent

The solvent in the detergent container might become muddy after long-time washing. The solvent can be recycled through the following treatment. (It is recommended to dispose or replace the solvent after one month/ washing 20 10.1" height models , to ensure the washing effect.)

- 1. Pour the solvent into another bucket and allow it stay still for over 10 hours so the residue could be precipitated and settled. At this time, you can clean the detergent container with water.**
- 2. Filter the top layer of solvent and pour it into the detergent container. Then, cover the container.**
- 3. Expose the residue in the sunlight. Then, the cured resin can be handled as general solid waste.**

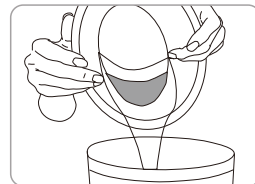

Cleaning

Please turn off the machine and unplug the power before cleaning.

1. Clean the rotor:

If the rotor rotates abnormally after long-term use, you can remove the rotor from drum to clean it.

① Open the door, remove the rotor at the bottom of drum.

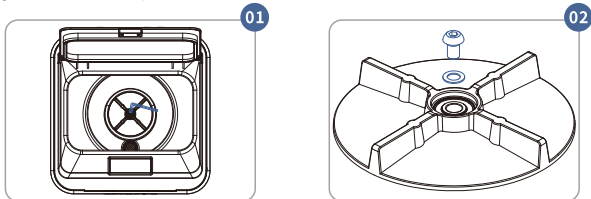

② Clean the rotor. Then, install the rotor.

2. Clean the strainers in the drum: Please clean the strainers periodically to avoid the residue and other foreign matters block it.

① Open the door and take out the two strainers at the bottom of the drum.

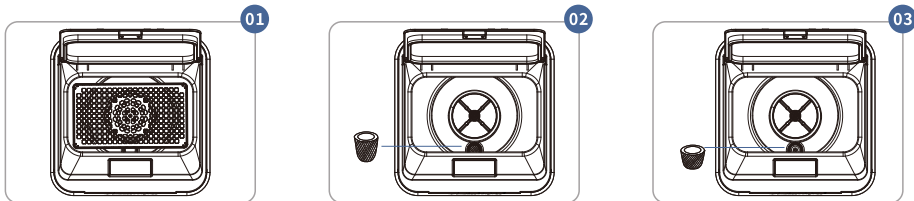

Take out the tray

Take out the upper strainer

Take out the lower strainer

② Clean the strainers with a brush.

③ Install the two strainers.

3.Clean the drum: Pour water into the drum and clean it with the plastic scraper. Never scratch the inner wall with sharp objects. After cleaning, plug in the power and turn on the machine. Long press the CANCEL button for 3 seconds and then It will drain off the waste water.

4.Clean/replace the filter in the container: Please clean the filter periodically to avoid the foreign matters block it.

① Open the lid and take out the filter. (The pictures here take the detergent container as an example.)

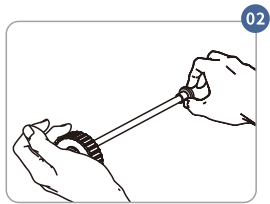
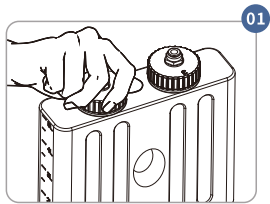

② Clean the filter with a brush. If the filter is used for over 3 months or hard to be cleaned, please replace it.

③ Install the filter.

5.Clean the machine: Please clean the machine before it is left unused for a long time. If there are accessories or parts being contaminated, clean them according to the Part 1-4 of Cleaning and then overall wash the machine by the steps below.

① Drain the detergent and water containers, and then wash the containers.

② Put the pipes 1/2/3 into a container filled with water. Keep pipe 4 in the bucket.

③ Close the machine door, set the wash & cure mode and then press START/PAUSE button to start the process.

④ When the process is finished, wait until the drum is dry and store the machine in a dark, cool place.

Pipe replacement

If the pipes are broken, please replace them timely.

1. Turn off the machine and unplug the power.

2. Take off the stopper first. Then, press the safety valve of the L-shaped connector and pull out the pipe.

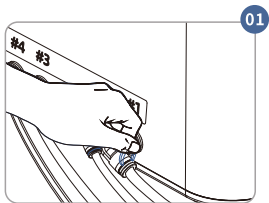

Remove the stopper

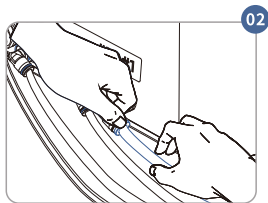

Press the safety valve
and pull out the pipe

3. Insert the new pipe into the L-shaped connector and then install the stopper.

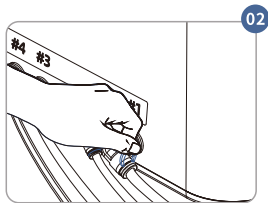
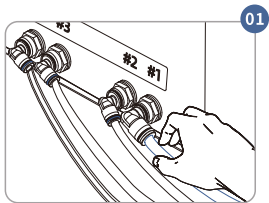

06 Troubleshooting

1. The machine does not work.

- Poor power contact. Pull out the power cord and plug it in again.
- Please contact our technical support if the solution above cannot solve your problem.

2. The rotor inside the washing drum does not rotate during the washing process.

- The rotor inside the washing drum is stuck by foreign matter. Press CANCEL button and wait for the machine stops. Then, turn off the machine and open the door to remove the foreign matter. Then turn on the machine to wash and cure.
- There are too much precipitation in the solvent. Press CANCEL button and wait for the machine stops. Then, turn off the machine and open the door to cleaning the precipitation. Then turn on the machine to wash and cure.

3. The machine has abnormal sound during operation.

- The ground where the machine is placed is not flat enough.
- The screw on the rotor is loose. Tighten the screw.

4. Part of print objects are white after wash and cure

- The concentration of the alcohol which is used for washing is not high enough. Use alcohol with concentration exceeding 95%.

5. When mode button is pressed to switch mode, the two mode lights are not lit.

- Try again or reboot the machine.

6. The machine does not work and reports error: E20

- The door is not closed. Close the door and the machine will work.

7. The machine pauses the washing and reports error: E11

- There is no water. Check the water volume and fill up the container. Then, press START/PAUSE button and the machine will continue the process before.

8. The machine pauses the washing and reports error: E12

- The outlet of water/detergent is blocked. The door will unlock this time.
Please clean the blockage in the drum or drainer. Then, close the door and press START/PAUSE button.
The machine will continue the process before.
- The machine is not level. Please place it to a stable, level workspace. Then, close the door and press START/PAUSE button. The machine will continue the process before.

Thank you for purchasing Anycubic products! Please visit Anycubic support center(support.anycubic.com/en) to report any issues with Anycubic products. Our professional after-sale service team would respond within 24 hours and solve the issues.



Name: APEX CE SPECIALISTS LIMITED
Add: 89 Princess Street, Manchester, M1 4HT, UK
Contact: Wells
Tel: + 441616371080
E-mail: info@apex-ce.com



Name: Apex CE Specialists GmbH
Add: Habichtweg 1 41468 Neuss Germany
Contact: Wells Yan
Tel: +353212066339
E-mail: info@apex-ce.com

FC CE RoHS



UK CA



M02030342