

ENERGY[®]

BATTERY



www.energybatterytr.com



ESAN BATTERY AND MATERIALS INDUSTRY & TRADE INC.

Esan Battery was established in 1978 in Istanbul and started the production of batteries under the title Esan Battery and Materials Industry & Trade Inc. For many years, the company continued manufacturing operations in 4. Levent, as a requirement of increasing business volume and growing need of organizational structure, in 1999 a modern production facility was built in Ayazaga.

Our company has completed ISO 9001 Quality Management System work in 2006, and entitled to receive a certificate. Now continues of work certifications: ISO 14001 Environmental Management System and OHSAS 18001 Occupational Health and Safety. In 2012, has started to work on ISO/TS 16949:2009 Automotive Quality Management System.

In 2005, it became the number 1 and founding member of the AKÜDER (Association of Accumulator and Recycling Industrialists), authorized by the Ministry of Environment and Forests.

*Along with growing sales network and organization, **Esan Battery** serves customers via dealers across the country, region, sub-dealers and after-sales service points. 60% of production of **Esan Battery**, is exported three continents.*

*In 2016, **Esan Battery** moved to Gebze and started to run its operations here. Within 40 years of experience, knowledge and also "**Positive Energy**" motto, **Esan Battery** adopted the principle Environmental Awareness and Customer Satisfaction.*



ENERGY[®]
BATTERY

**Charge level indicator
integrated on lid**

**Terminal design
for new battery**

**Ergonomic battery
handle design**

New label design

New battery case design



ENERGY[®]

BATTERY

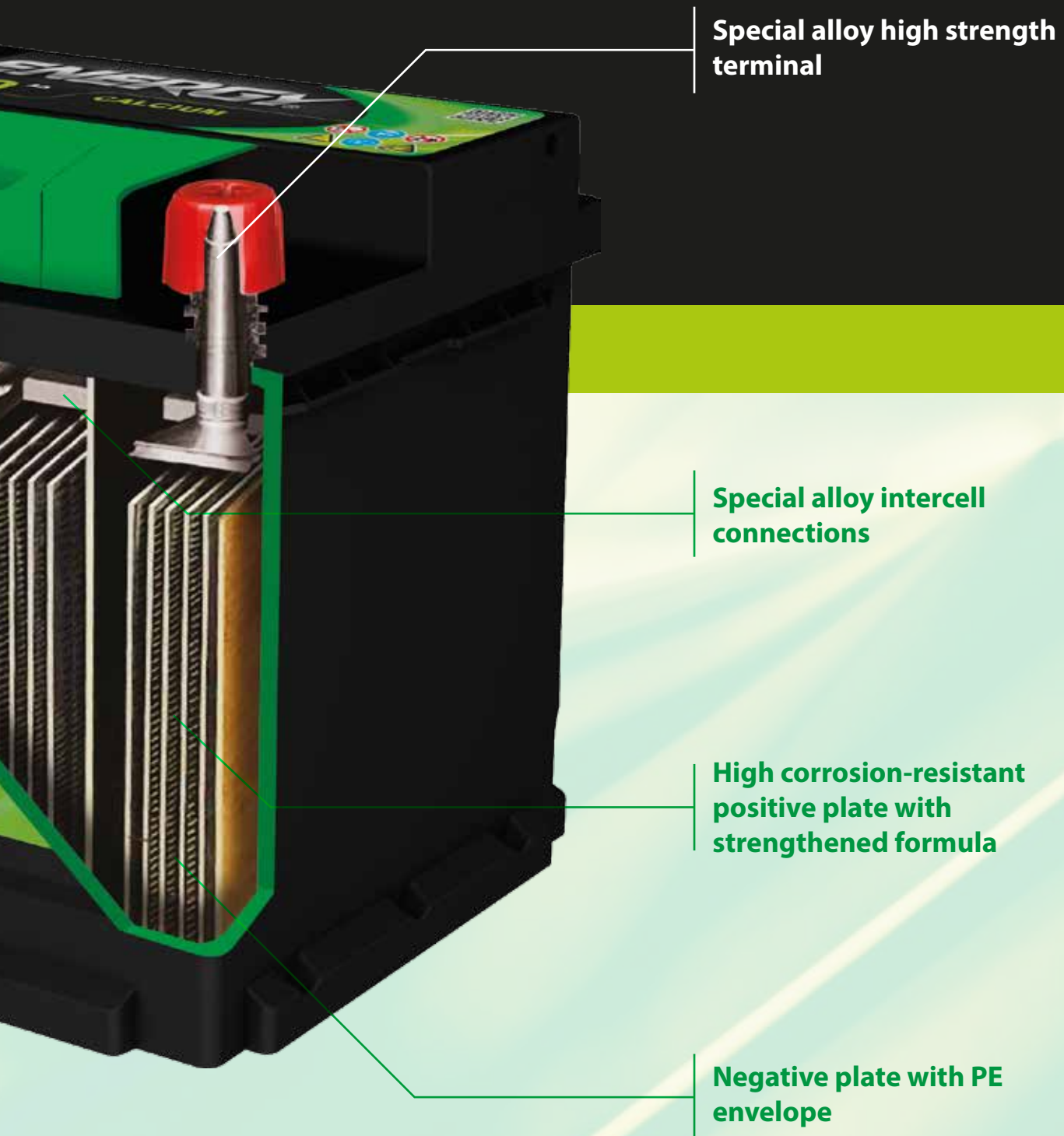

ENERGY[®]

BATTERY

Step to Foreign Market

Esan Battery, which attaches important to development each period and exports 65% of its production to more than 40 countries currently in Europe, Asia and Africa continents, opened to foreign market in **1997**.

World Brand

It continued its branding process starting with **Esan** in **1985** with **Energy, Vega** and **Pure Energy**.

Young Energy is In Charge

It started to work actively as second generation in **1998**.

1980

1990

2000

Establishment Years

Foundations of **Esan Battery** were laid in 4.Levent by Teoman Sunkar and Mehmet Reşat Birmiş, in **1978**. The Company has been continuing its production activities for many years.

Expansion of Work Area

It carried its entire production and management activities to its modern facilities located in Şişli Ayazağa to perform increasing work load and growing organization structure requirement in **1999**.

Star of The Sector

Investments were made on industry 4.0, efficiency, robot usage, automation, ergonomics and new generation environmental protection systems continuing in **2017** in Gebze facilities, and state-of-the-art and high technologies were gained.

Sustainable Excellence

Esan Battery is one of the most successful companies of Turkey in the sector with its endorsement, exportation, young and dynamic employees. **Esan Battery**, which continuously reinforced its position with awards it received in national and international platform, continues to carry out all of its activities with environmental protection principle, sense of social responsibility, employee and customer satisfaction.

Esan Battery proceeds fast on its way that it started in **1978** with the target of becoming a world brand with its young and dynamic team and thanks to its increasing sales network and organization, local dealer, sub dealer and after sales service points in nationwide.

Sector Leader

It became 1st and founder member of AKÜDER (Association of Accumulator and Recycling Industrialists) authorized by the Ministry of Environment and Forestry in **2005**.

Capacity Increase

Esan Battery, completing exmet production line investment that it imported from Canada and America in **2011**, reached **1 million and 200 thousand** production capacity per year.

ISO 10002

Completed ISO 10002 "Customer Satisfaction Management System" studies in **2018** and which gained right to receive document

Solution Center

It started to produce fully closed accumulator in **2008**.

Technology Investments

It made investment on line automation, robot usage and new technologies on accumulator systems within the scope of modernization of current production lines in **2014**.

2010

2020

Step for Joint-stock Company

Esan Battery and Materials Industry & Trade Inc. was established in **2010** following target of reinforcing corporate identity.

Firm Steps in The Light of New Targets

It started production as of September of **2016** in its new facilities established on an area of 20 thousand square meters in Gebze Organized Industrial Zone, and **Esan Battery**, continuing to carry out activity with its target of production capacity of 2.500.000 number/year, aims at ranking among second 500 industrial companies in **2017** and among first 500 industrial companies in **2019**.

Importance Attached to Quality

Esan Battery, which completed ISO 9001 Quality Management System studies in **2006** and which gained right to receive document, completed ISO 14001 Environmental Management System and OHSAS 18001 Occupational Health and Safety certification studies.

Superior Quality

Importance that **Esan Battery** attached on each area as of the date when it was established was registered with its membership to Turkish Quality Association (KalDer) in **2015**.

ENERGY[®]
BATTERY

The **WORLD**
Gets
its **Energy**
from **US!**



www.energybatterytr.com





Lid
Types

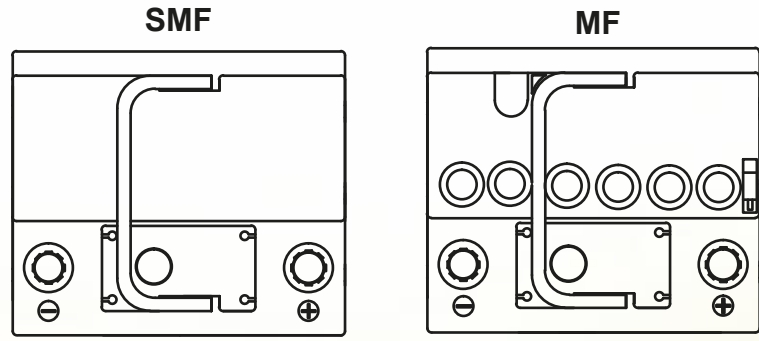

Layout
Types

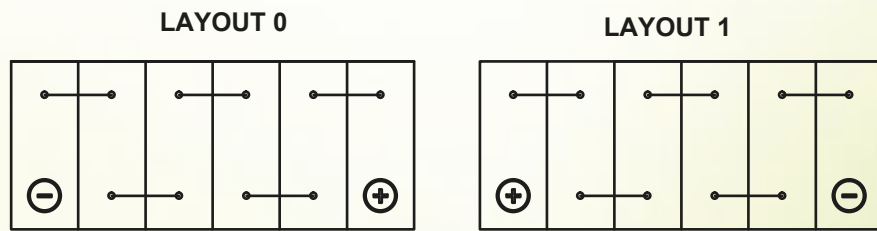

Terminal
Types

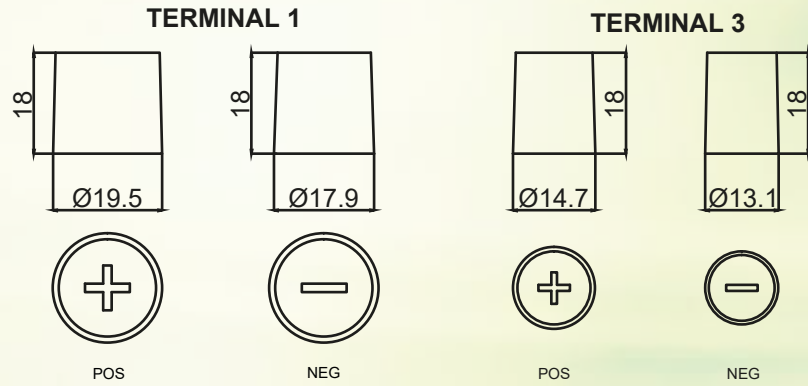

Hold-down
Types

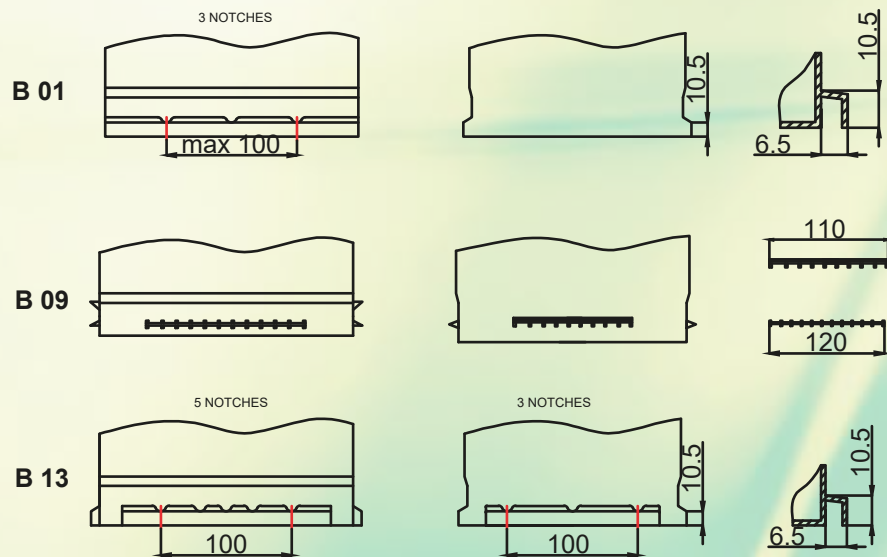



LB1 & L1 EUROPEAN VEHICLES

Box Type	Dimensions (mm)			Hold-down	Pieces / Pallet	
	L	W	H		Container	Truck
LB1	207	175	175	B13	80	120
L1	207	175	190	B13	80	120

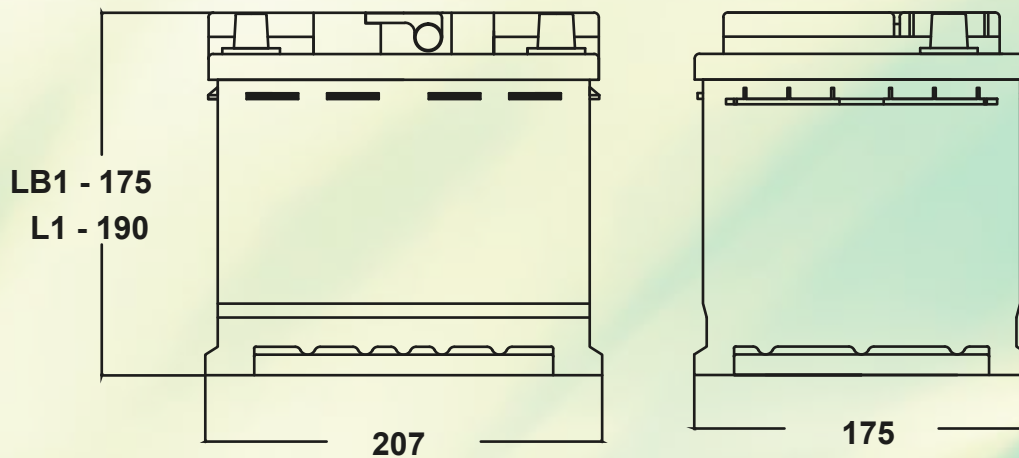

Box Type	Product Number		Capacity Ah/20h	CCA		Terminal	Lay-out	Hold-down
	MF	SMF		EN	DIN			
LB1	LB1 044 10B13	S LB1 044 10B13	44	360	220	1	0/1	B13
	LB1 045 10B13	S LB1 045 10B13	45	360	220	1	0/1	B13
	LB1 050 10B13	S LB1 050 10B13	50	420	230	1	0/1	B13
L1	L1 044 10B13	S L1 044 10B13	44	360	220	1	0/1	B13
	L1 045 10B13	S L1 045 10B13	45	360	220	1	0/1	B13
	L1 050 10B13	S L1 050 10B13	50	420	230	1	0/1	B13

LB2 & L2

EUROPEAN VEHICLES



Box Type	Dimensions (mm)			Hold-down	Pieces / Pallet	
	L	W	H		Container	Truck
LB2	242	175	175	B13	72	112
L2	242	175	190	B13	72	112

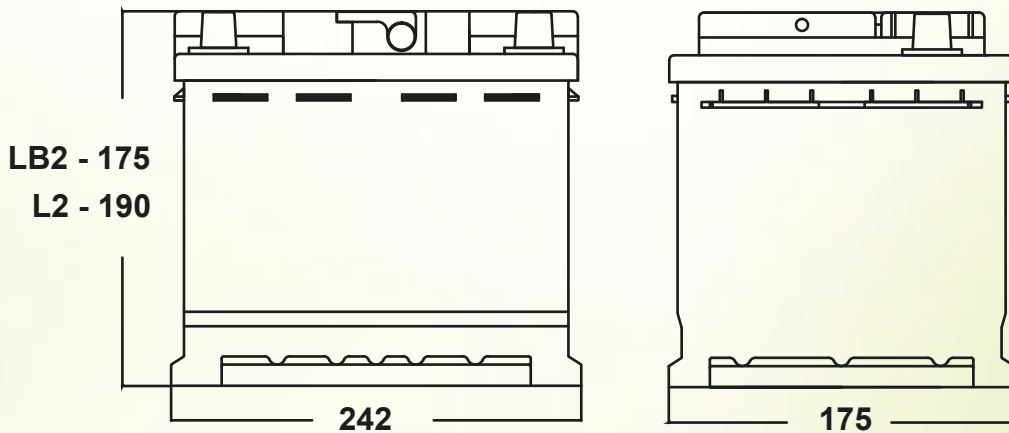

Box Type	Product Number		Capacity Ah/20h	CCA		Terminal	Lay-out	Hold-down
	MF	SMF		EN	DIN			
LB2	LB2 050 10B13	S LB2 050 10B13	50	420	230	1	0/1	B13
	LB2 055 10B13	S LB2 055 10B13	55	460	240	1	0/1	B13
	LB2 060 10B13	S LB2 060 10B13	60	540	255	1	0/1	B13
	LB2 062 10B13	S LB2 062 10B13	62	550	290	1	0/1	B13
L2	L2 050 10B13	S L2 050 10B13	50	420	230	1	0/1	B13
	L2 055 10B13	S L2 055 10B13	55	460	240	1	0/1	B13
	L2 060 10B13	S L2 060 10B13	60	540	255	1	0/1	B13
	L2 062 10B13	S L2 062 10B13	62	550	290	1	0/1	B13

2.500.000 BATTERY/YEAR PRODUCTION CAPACITY WITH EXPANDED METAL TECHNOLOGY.

PRODUCTION MANAGEMENT CONFIRMING TO ISO 9001, ISO 14001 AND OHSAS 18001 STANDARDS



LB3 & L3 EUROPEAN VEHICLES

Box Type	Dimensions (mm)			Hold-down	Pieces / Pallet	
	L	W	H		Container	Truck
LB3	278	175	175	B13	64	100
L3	278	175	190	B01	64	100

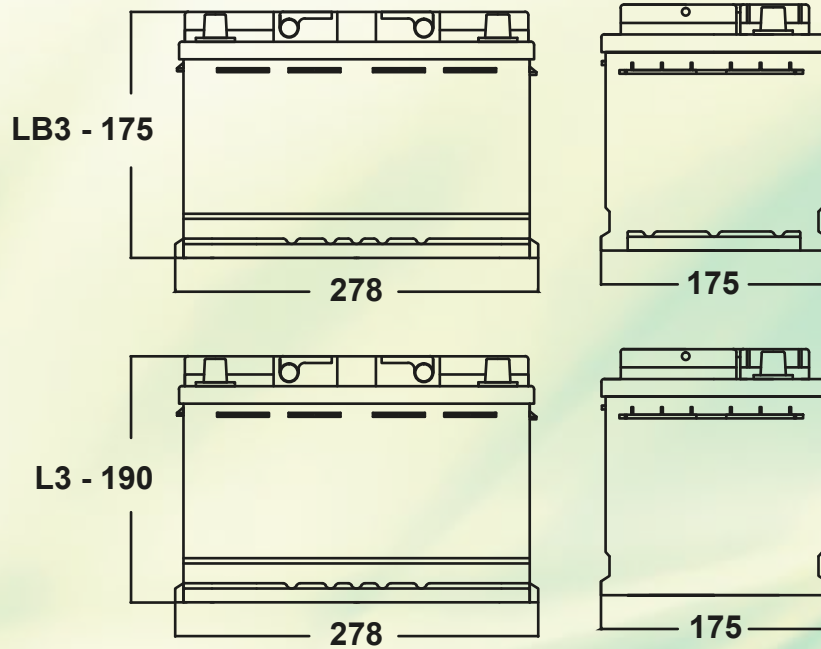

Box Type	Product Number		Capacity Ah/20h	CCA		Terminal	Lay-out	Hold-down
	MF	SMF		EN	DIN			
LB3	LB3 066 10B13	S LB3 066 10B13	66	590	300	1	0/1	B13
	LB3 072 10B13	S LB3 072 10B13	72	640	360	1	0/1	B13
	LB3 074 10B13	S LB3 074 10B13	74	650	380	1	0/1	B13
	LB3 075 10B13	S LB3 075 10B13	75	650	380	1	0/1	B13
L3	L3 066 10B01	S L3 066 10B01	66	590	300	1	0/1	B01
	L3 072 10B01	S L3 072 10B01	72	640	360	1	0/1	B01
	L3 074 10B01	S L3 074 10B01	74	650	380	1	0/1	B01
	L3 075 10B01	S L3 075 10B01	75	650	380	1	0/1	B01

LB4 & L4 EUROPEAN VEHICLES



Box Type	Dimensions (mm)			Hold-down	Pieces / Pallet	
	L	W	H		Container	Truck
LB4	315	175	175	B13	48	54
L4	315	175	190	B13	48	54

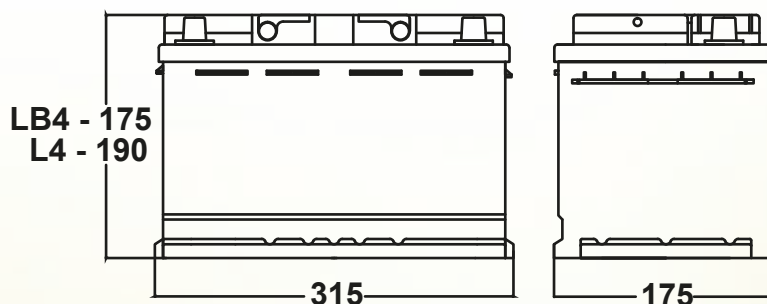

Box Type	Product Number		Capacity Ah/20h	CCA		Terminal	Lay-out	Hold-down
	MF	SMF		EN	DIN			
LB4	LB4 080 10B13	S LB4 080 10B13	80	700	410	1	0/1	B13
L4	L4 080 10B13	S L4 080 10B13	80	700	410	1	0/1	B13

LB5 & L5

Box Type	Dimensions (mm)			Hold-down	Pieces / Pallet	
	L	W	H		Container	Truck
LB5	353	175	175	B13	48	54
L5	353	175	190	B13	48	54

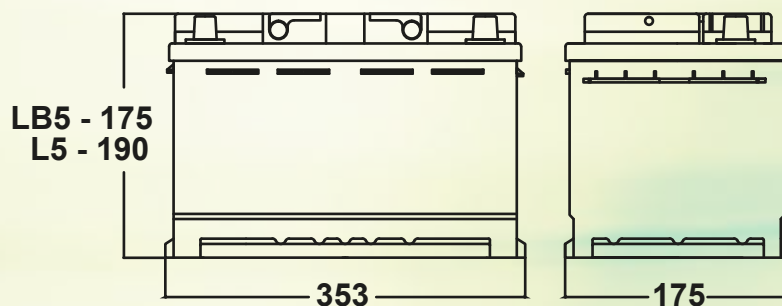

Box Type	Product Number		Capacity Ah/20h	CCA		Terminal	Lay-out	Hold-down
	MF	SMF		EN	DIN			
LB5	LB5 088 10B13	S LB5 088 10B13	88	720	420	1	0/1	B13
	LB5 100 10B13	S LB5 100 10B13	100	800	480	1	0/1	B13
L5	L5 088 10B13	S L5 088 10B13	88	720	420	1	0/1	B13
	L5 100 10B13	S L5 100 10B13	100	800	480	1	0/1	B13

2.500.000 BATTERY/YEAR PRODUCTION CAPACITY WITH EXPANDED METAL TECHNOLOGY.

PRODUCTION MANAGEMENT CONFIRMING TO ISO 9001, ISO 14001 AND OHSAS 18001 STANDARDS



H4

EUROPEAN VEHICLES

Box Type	Dimensions (mm)			Hold-down	Pieces / Pallet	
	L	W	H		Container	Truck
H4	343	175	220	B03	48	54

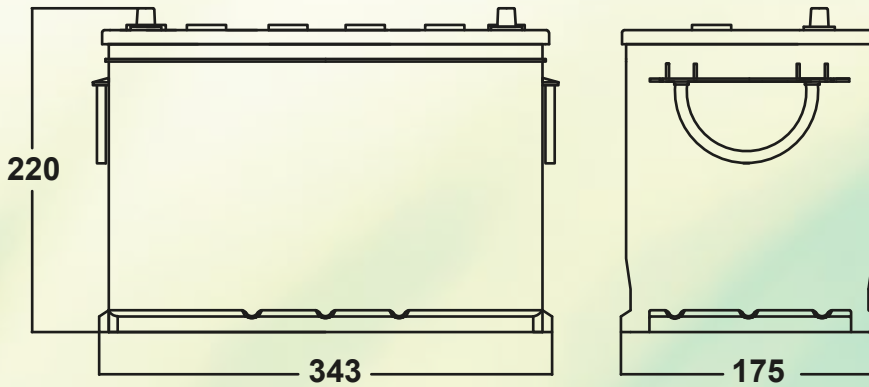

Box Type	Product Number	Capacity Ah/20h	CCA		Terminal	Lay-out	Hold-down
	MF		EN	DIN			
H4	H4 105 10B03	105	760	440	1	0/1	B03
	H4 110 10B03	110	780	490	1	0/1	B03

You have Positive Energy
with Esan Battery!



NS40 (B19)

ASIAN VEHICLES



Box Type	Dimensions (mm)			Hold-down	Pieces / Pallet	
	L	W	H		Container	Truck
NS40	195	126	225	B00	108	150

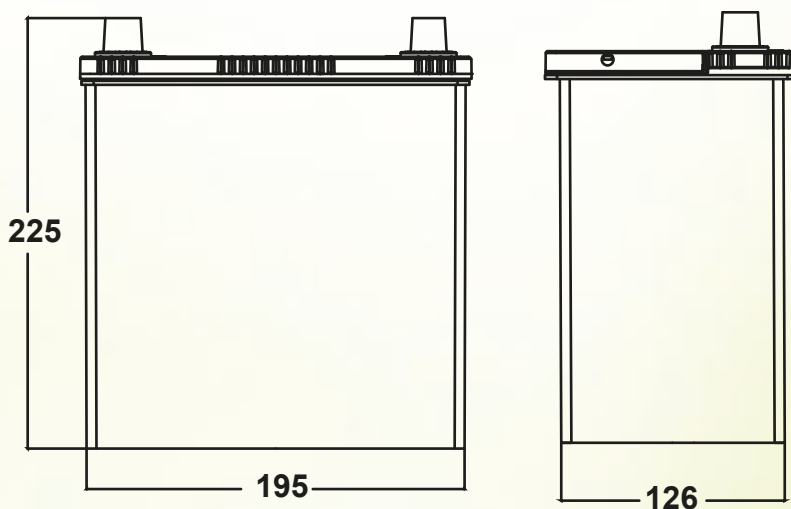

Box Type	Product Number		Capacity Ah/20h	CCA		Terminal	Lay-out	Hold-down
	MF	SMF		EN	DIN			
NS40	NS40 035 30B00	S NS40 035 30B00	35	240	150	3	0/1	B00
	NS40 040 30B00	S NS40 040 30B00	40	270	170	3	0/1	B00
	NS40 042 30B00	S NS40 042 30B00	42	330	200	3	0/1	B00

2.500.000 BATTERY/YEAR PRODUCTION CAPACITY WITH EXPANDED METAL TECHNOLOGY.

PRODUCTION MANAGEMENT CONFIRMING TO ISO 9001, ISO 14001 AND OHSAS 18001 STANDARDS



NS60 (B24)

ASIAN VEHICLES

Box Type	Dimensions (mm)			Hold-down	Pieces / Pallet	
	L	W	H		Container	Truck
NS60	236	126	225	B00	90	135

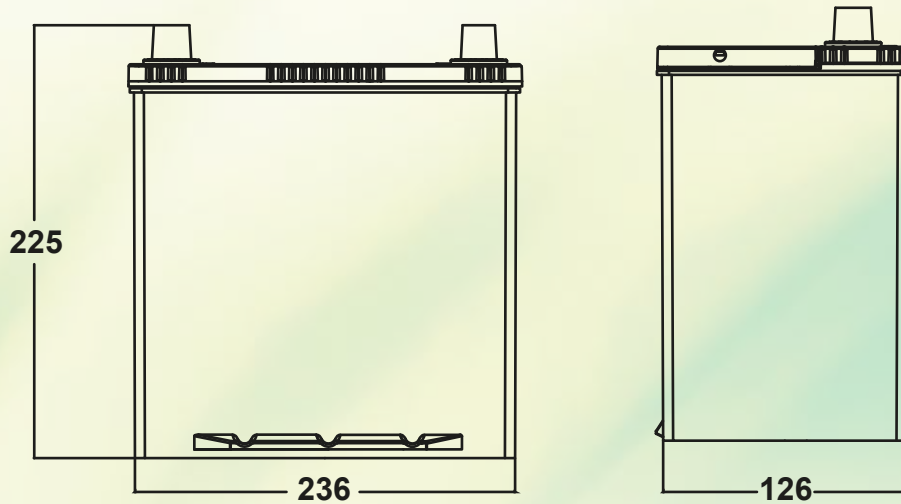

Box Type	Product Number		Capacity Ah/20h	CCA		Terminal	Lay-out	Hold-down
	MF	SMF		EN	DIN			
NS60	NS60 045 30B00	S NS60 045 30B00	45	360	220	3	0/1	B00
	NS60 045 10B00	S NS60 045 10B00	45	360	220	1	0/1	B00

D23

ASIAN VEHICLES



Box Type	Dimensions (mm)			Hold-down	Pieces / Pallet	
	L	W	H		Container	Truck
D23	229	171	215	B01	80	93

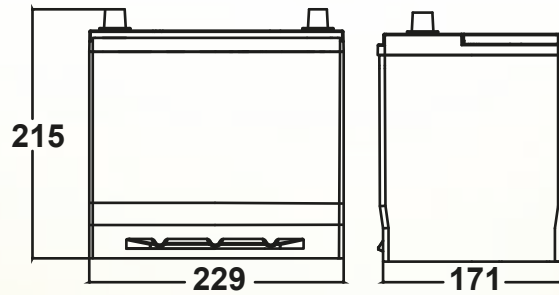

Box Type	Product Number		Capacity Ah/20h	CCA		Terminal	Lay-out	Hold-down
	MF	SMF		EN	DIN			
D23	D23 055 10B01	S D23 055 10B01	55	460	240	1	0/1	B01
	D23 060 10B01	S D23 060 10B01	60	540	255	1	0/1	B01

N50 (D26)

Box Type	Dimensions (mm)			Hold-down	Pieces / Pallet	
	L	W	H		Container	Truck
N50	261	175	216	B09	64	100

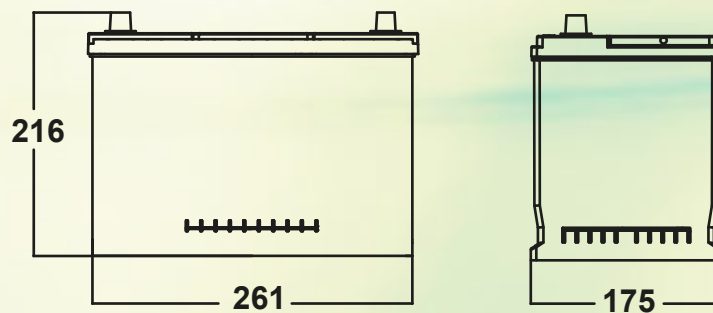

Box Type	Product Number		Capacity Ah/20h	CCA		Terminal	Lay-out	Hold-down
	MF	SMF		EN	DIN			
N50	N50 070 10B09	S N50 070 10B09	70	600	340	1	0/1	B09

2,500,000 BATTERY/YEAR PRODUCTION CAPACITY WITH EXPANDED METAL TECHNOLOGY.

PRODUCTION MANAGEMENT CONFIRMING TO ISO 9001, ISO 14001 AND OHSAS 18001 STANDARDS



N70 (D31)

ASIAN VEHICLES

Box Type	Dimensions (mm)			Hold-down	Pieces / Pallet	
	L	W	H		Container	Truck
N70	329	175	225	B01	36	54

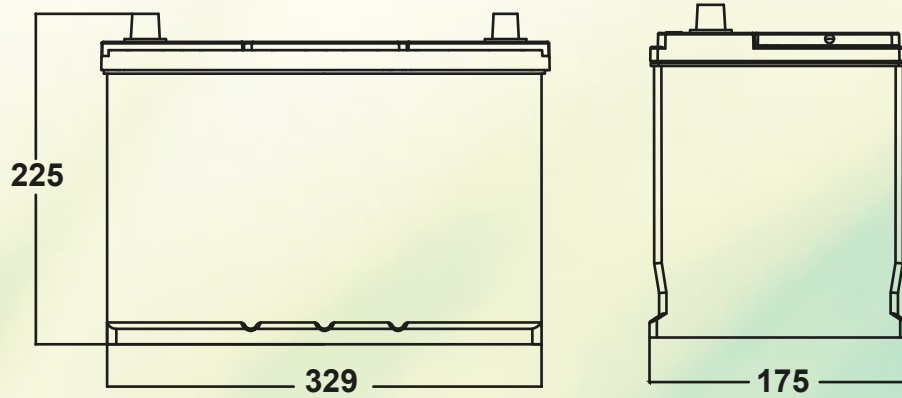

Box Type	Product Number		Capacity Ah/20h	CCA		Terminal	Lay-out	Hold-down
	MF	SMF		EN	DIN			
N70	N70 090 10B01	S N70 090 10B01	90	720	370	1	0/1	B01
	N70 100 10B01	S N70 100 10B01	100	800	480	1	0/1	B01



HEAVY DUTY



Lid Types

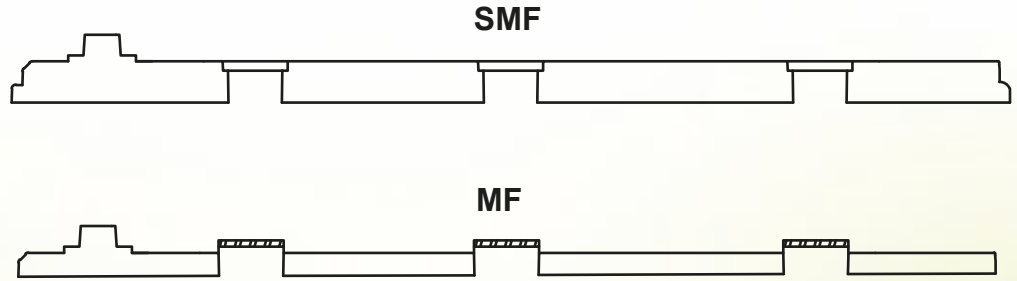

Layout Types

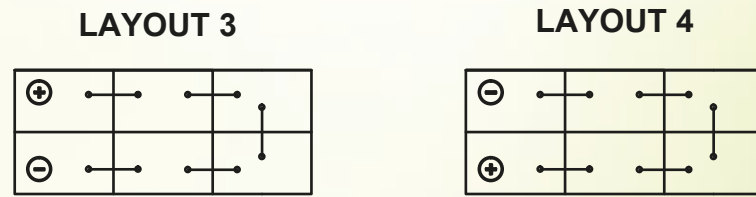

Terminal Types

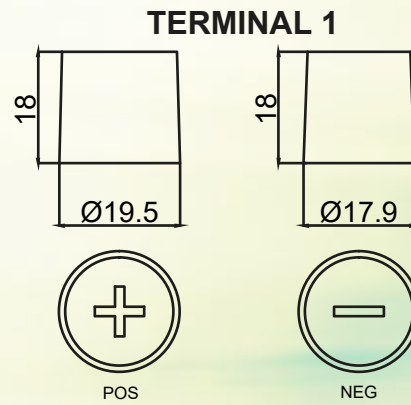

Hold-down Types

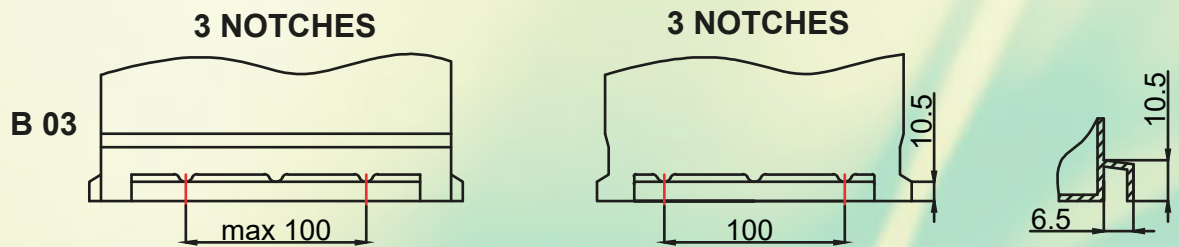



A (D4A) HEAVY DUTY

Box Type	Dimensions (mm)			Hold-down	Pieces / Pallet	
	L	W	H		Container	Truck
A	512	180	219	B03	24	36



Box Type	Product Number		Capacity Ah/20h	CCA		Terminal	Lay-out	Hold-down
	MF	SMF		EN	DIN			
A	A 120 13B03	S A 120 13B03	120	850	420	1	3/4	B03
	A 135 13B03	S A 135 13B03	135	950	450	1	3/4	B03



ESAN BATTERY acts on the principle of respect for nature in all its activities and in all decisions, this principle is taken into consideration. To create this awareness among the employees and other stakeholders, trainings and awareness-raising activities are organized.

B (D5A) HEAVY DUTY



Box Type	Dimensions (mm)			Hold-down	Pieces / Pallet	
	L	W	H		Container	Truck
B	516	220	206	B00	28	30

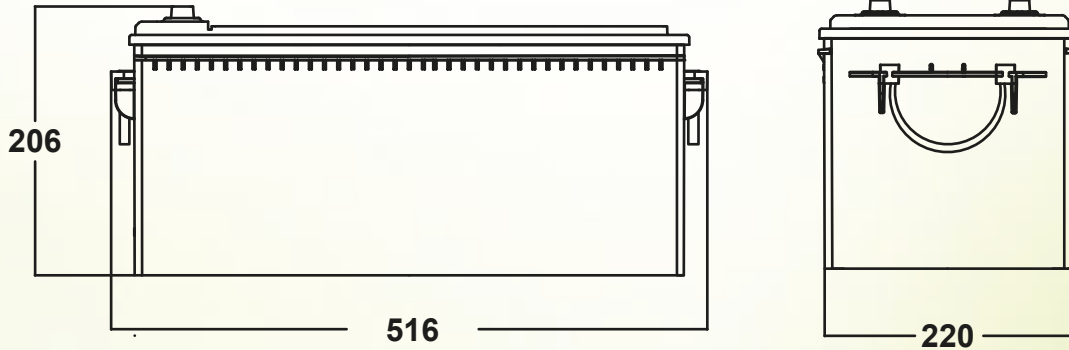

Box Type	Product Number		Capacity Ah/20h	CCA		Terminal	Lay-out	Hold-down
	MF	SMF		EN	DIN			
B	B 150 13B00	S B 150 13B00	150	1000	500	1	3/4	B00
	B 165 13B00	S B 165 13B00	165	1100	550	1	3/4	B00
	B 180 13B00	S B 180 13B00	180	1150	600	1	3/4	B00
	B 190 13B00	S B 190 13B00	190	1180	620	1	3/4	B00

<p>Turkish Standart Institution</p> <p>Turkey Standarts Certificate of Conformity</p>	<p>ISO 9001</p> <p>Quality Management System</p>	<p>ISO 14001</p> <p>Environmental Management System</p>	<p>OHSAS 18001</p> <p>Occupational Health and Safety</p>	<p>ISO 10002</p> <p>Quality Management System</p>	<p>GOST-R</p> <p>Rusia Standarts Certificate of Conformity</p>	<p>Acid Resirculation Investment</p> <p>Quality Management System</p>	<p>Expanded Metal Technology Investment</p> <p>Canada 2011</p>	<p>IATF 16949</p> <p>In Progress</p>	<p>Lead Analysis laboratory</p>	<p>Acid Analysis laboratory</p>	<p>R-D Center Set Up Studies</p>
---------------------------------------------------------------------------------------	--------------------------------------------------	---------------------------------------------------------	----------------------------------------------------------	---------------------------------------------------	----------------------------------------------------------------	-----------------------------------------------------------------------	----------------------------------------------------------------	--------------------------------------	---------------------------------	---------------------------------	----------------------------------

2.500.000 BATTERY/YEAR PRODUCTION CAPACITY WITH EXPANDED METAL TECHNOLOGY.

PRODUCTION MANAGEMENT CONFIRMING TO ISO 9001, ISO 14001 AND OHSAS 18001 STANDARDS



C (D6) HEAVY DUTY

Box Type	Dimensions (mm)			Hold-down	Pieces / Pallet	
	L	W	H		Container	Truck
C	516	275	239	B00	24	24

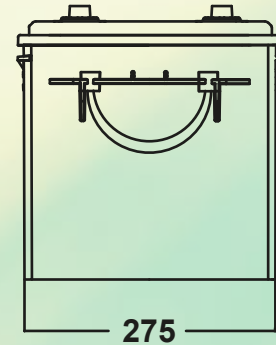
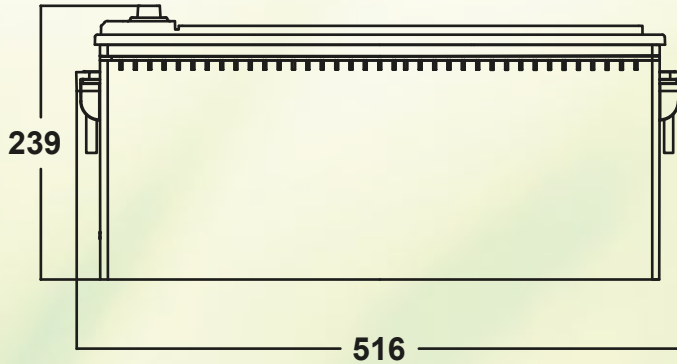

Box Type	Product Number		Capacity Ah/20h	CCA		Terminal	Lay-out	Hold-down
	MF	SMF		EN	DIN			
C	C 200 13B00	S C 200 13B00	200	1200	630	1	3/4	B00
	C 210 13B00	S C 210 13B00	210	1220	650	1	3/4	B00
	C 225 13B00	S C 225 13B00	225	1250	700	1	3/4	B00
	C 240 13B00	S C 240 13B00	240	1400	750	1	3/4	B00

CERTIFICATES

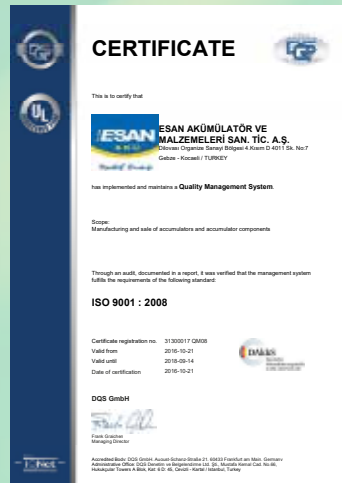

ENERGY[®]

BATTERY

🏠 Dilovası OSB 4. Kısım D 4011 Sok. No: 7 Gebze 41455 Kocaeli - Türkiye

☎ +90 262 502 17 40 ☎ +90 850 227 37 26 🏢 +90 262 502 17 38 📞 +90 533 453 25 57
@ esan@esanaku.com



www.energybatterytr.com