

### Specificație Completată

#### Lampă chirurgicală cu 1 satelit (caracteristici de baza)

Model: Q-Flow4 Producător: Merivaara; Tara: Finlanda

Specificarea tehnică deplină solicitată de către autoritatea contractantă	Specificarea tehnică deplină propusă de către autoritatea ofertantă
<p>Lampă chirurgicală cu 1 satelit (caracteristici de baza) Cod 130200 Descriere Lampă chirurgicală fără umbre destinată pentru iluminare în investigații chirurgicale majore cu fixare pe tavan Parametrul Specificația Caracteristici tehnice Sistem de iluminare bazat pe tehnologia LED (Light Emitting Diodes) da Numărul de sateliți 1 Temperatura culorii 4,500 ±500 K</p> <p>Reglarea intensității da Indexul de culoare ≥ 95 Dimensiunea câmpului, cm Diametrul 20 - 28 cm Adâncimea ≥ 80 cm Distanța de lucru 0.7-1.2 m Nivelul de iluminare la 1 m distanță ≥ 120000 lux Rotația 270 grade Ajustare pe verticală, cm ≥ 70 Cresterea temperaturii în câmpul operator &lt; 1° C Alimentarea Rețeaua electrică 220V, 50Hz Durata medie de viață a LED-urilor min. 50 000 h Mînere detașabile sterilizabile Panou de control integrat în lampa principal</p> <p>Înălțimea podului 3-4 m</p>	<p>Lampă chirurgicală cu 1 satelit (caracteristici de baza) Cod 130200 Descriere Lampă chirurgicală fără umbre destinată pentru iluminare în investigații chirurgicale majore cu fixare pe tavan <b>DA</b> Parametrul Specificația Caracteristici tehnice Sistem de iluminare bazat pe tehnologia LED (Light Emitting Diodes) <b>DA</b> Numărul de sateliți 1 <b>DA</b> Temperatura culorii 3700/4400/5100 <b>DA la alegerea utilizatorului</b> Reglarea intensității <b>DA</b> Indexul de culoare 98 <b>DA</b> Dimensiunea câmpului, cm Diametrul 20 - 32 cm <b>DA</b> Adâncimea - 80 cm <b>DA</b> Distanța de lucru 0.6-1.7 m <b>DA</b> Nivelul de iluminare la 1 m distanță - 140000 lux <b>DA</b> Rotația 270 grade <b>DA</b> Ajustare pe verticală, cm - 70 <b>DA</b> Cresterea temperaturii în câmpul operator &lt; 1° C <b>DA</b> Alimentarea Rețeaua electrică 220V, 50Hz <b>DA</b> Durata medie de viață a LED-urilor min. 50 000 h <b>DA</b> Mînere detașabile sterilizabile <b>DA</b> Panou de control integrat în lampa principal <b>DA tip touch in limba romina</b> Înălțimea podului 3-4 m <b>DA</b></p>

### Specificație Completată

#### Lampa chirurgicala cu 1 satelit (caracteristici avansate)

Model: Q-Flow 4 Producător: Merivaara; Tara: Finlanda

Specificarea tehnică deplină solicitată de către autoritatea contractantă	Specificarea tehnică deplină propusă de către autoritatea ofertantă
<p>Lampa chirurgicala cu 1 satelit (caracteristici avansate) Cod 130210 Descriere Lampă chirurgicală fără umbre destinată pentru iluminare în investigații chirurgicale majore cu fixare pe tavan Parametrul Specificația Caracteristici tehnice Sistem de iluminare bazat pe tehnologia LED (Light Emitting Diodes) da Numărul de sateliți 1 Temperatura culorii 4,500 ±500 K reglabilă</p> <p>Reglarea intensității da Indexul de culoare ≥ 95 Dimensiunea câmpului, cm Focusabil da Diametrul 20-28 cm Adâncimea ≥ 80 cm Distanța de lucru 0.7-1.5 m Nivelul de iluminare la 1 m distanță ≥ 130000 lux Rotația 270 grade Ajustare pe verticală, cm ≥ 80 Cresterea temperaturii în câmpul operator &lt;1° C Alimentarea Rețeaua electrică 220V, 50Hz Durata medie de viață a LED-urilor min. 50000 h Mișcarea capului luminos ≥ 4 grade de libertate Mînere detașabile sterilizabile Panou de control integrat în lampa principal</p> <p>Posibilitatea integrării sistemului de telemedicină și a sistemelor de înregistrare video da Înălțimea podului 3-4 m</p>	<p>Lampa chirurgicala cu 1 satelit (caracteristici avansate) Cod 130210 Descriere Lampă chirurgicală fără umbre destinată pentru iluminare în investigații chirurgicale majore cu fixare pe tavan <b>DA</b> Parametrul Specificația Caracteristici tehnice Sistem de iluminare bazat pe tehnologia LED (Light Emitting Diodes) <b>DA</b> Numărul de sateliți 1 <b>DA</b> Temperatura culorii 3700/4400/5100 <b>DA la alegerea utilizatorului</b> Reglarea intensității <b>DA</b> Indexul de culoare 98 <b>DA</b> Dimensiunea câmpului, cm Focusabila <b>DA</b> Diametrul 20 - 32 cm <b>DA</b> Adâncimea - 80 cm <b>DA</b> Distanța de lucru 0.6-1.7 m <b>DA</b> Nivelul de iluminare la 1 m distanță - 140000 lux <b>DA</b> Rotația 270 grade <b>DA</b> Ajustare pe verticală, cm - 80 <b>DA</b> Cresterea temperaturii în câmpul operator &lt; 1° C <b>DA</b> Alimentarea Rețeaua electrică 220V, 50Hz <b>DA</b> Durata medie de viață a LED-urilor min. 50 000 h <b>DA</b> Mișcarea capului luminos ≥ 4 grade de libertate Mînere detașabile sterilizabile <b>DA</b> Panou de control integrat în lampa principal <b>DA tip touch in limba romina</b> Posibilitatea integrării sistemului de telemedicină și a sistemelor de înregistrare video <b>DA este posibil</b> Înălțimea podului 3-4 m <b>DA</b></p>

### Specificație Completată

#### Lampa chirurgicala cu 2 sateliti (caracteristici avansate)

Model: Q-Flow 4+6 Producător: Merivaara; Tara: Finlanda

Specificarea tehnică deplină solicitată de către autoritatea contractantă	Specificarea tehnică deplină propusă de către autoritatea ofertantă
<p>Lampa chirurgicala cu 2 sateliti (caracteristici avansate) Cod 130230 Descriere Lampă chirurgicală fără umbre destinată pentru iluminare în investigații chirurgicale majore cu fixare pe tavan cu 2 sateliți Parametrul Specificația Caracteristici tehnice Sistem de iluminare bazat pe tehnologia LED (Light Emitting Diodes) da Numărul de sateliți 2 Temperatura culorii 4,500 ±500 K reglabilă Reglarea intensității da Indexul de culoare ≥ 95 Dimensiunea câmpului, cm Focusabil da Diametrul 20-28 cm Adâncimea ≥ 80 cm Distanța de lucru 0.7-1.5 m Nivelul de iluminare la 1 m distanță ≥ 120000 lux Reglarea intensității da Rotația 270 grade Ajustare pe verticală, cm ≥80 Cresterea temperaturii în câmpul operator &lt;1° C Alimentarea Rețeaua electrică 220V, 50Hz Durata medie de viață a LED-urilor min. 50000 h Mișcarea capului luminos ≥ 4 grade de libertate Mînere detașabile sterilizabile Panou de control integrat în lampa principal</p> <p>Posibilitatea integrării sistemului de telemedicină și a sistemelor de înregistrare video da Înălțimea podului 3-4 m</p>	<p>Lampa chirurgicala cu 2 sateliti (caracteristici avansate) Cod 130230 Descriere Lampă chirurgicală fără umbre destinată pentru iluminare în investigații chirurgicale majore cu fixare pe tavan cu 2 sateliți <b>DA</b> Parametrul Specificația Caracteristici tehnice Sistem de iluminare bazat pe tehnologia LED (Light Emitting Diodes) <b>DA</b> Numărul de sateliți 2 <b>DA Q-Flow 4+6</b> Temperatura culorii 3700/4400/5100 K reglabilă <b>DA</b> Reglarea intensității <b>DA</b> Indexul de culoare - 98 Dimensiunea câmpului, cm Focusabil <b>DA</b> Diametrul 20-37cm <b>DA</b> Adâncimea ≥ 80 cm <b>DA</b> Distanța de lucru 0.7-1.8 m <b>DA</b> Nivelul de iluminare la 1 m distanță - 300000 lux <b>DA</b> Reglarea intensității <b>dDA</b> Rotația 270 grade <b>DA</b> Ajustare pe verticală, cm ≥80 <b>DA</b> Cresterea temperaturii în câmpul operator &lt;1° C <b>DA</b> Alimentarea Rețeaua electrică 220V, 50Hz <b>DA</b> Durata medie de viață a LED-urilor min. 50000 h <b>DA</b> Mișcarea capului luminos ≥ 4 grade de libertate <b>DA</b> Mînere detașabile sterilizabile <b>DA</b> Panou de control integrat în lampa principal <b>DA tip touch screen in limba romina</b> Posibilitatea integrării sistemului de telemedicină și a sistemelor de înregistrare video <b>DA</b> Înălțimea podului 3-4 m <b>DA</b></p>



**DECLARATION OF CONFORMITY**  
**To European Council Directive 93/42/EEC**

**We**

**Merivaara Corp.**  
Puustellintie 2, FI-15150 LAHTI, FINLAND

**declare that the**

**Q-FLOW**

**Surgical Light System**

**Product codes: Q-FLOW SOLO 520210, Q-FLOW DUO 320 520220, Q-FLOW DUO 520222, Q-FLOW TRIO 520230, Q-FLOW MOBILE 520211**

**Consisting of one or more of following lamp heads, optionally equipped with wireless camera: LAMP HEAD Q-FLOW 4 520241, LAMP HEAD Q-FLOW 4i 520242, LAMP HEAD Q-FLOW 4 LCH 520243, LAMP HEAD Q-FLOW 4i LCH 520244, LAMP HEAD Q-FLOW 6 520251, LAMP HEAD Q-FLOW 6i 520252, LAMP HEAD Q-FLOW 6 LCH 520253, LAMP HEAD Q-FLOW 6i LCH 520254**

**Class I (Annex IX)**  
**GMDN group: 04, GMDN code: 37332**

**provided with specified accessories conforms to the European Council Directive 93/42/EEC, Medical Device Directive (Annex VII), corresponding Finnish National Law (629/2010) and European Council Directive 2014/53/EU (Radio Equipment Directive).**

The product is controlled in accordance with ISO 9001 and ISO 13485 Quality Management Systems and ISO 14001 Environmental Management System, and meets the requirements of following standards

- EN 60601-1: Medical electrical equipment. Part 1: General requirements for safety
- EN 60601-1-2: Collateral Standard: Electromagnetic compatibility - Requirements and tests.
- EN 60601-2-41: Medical electrical equipment. Part 2-41:  
Particular requirements for the safety of surgical luminaries and luminaries for diagnosis

August 23<sup>rd</sup>, 2018

  
Leena Viljo  
CEO

## EU DECLARATION OF CONFORMITY

**Manufacturer:** **Merivaara Corp.**  
Puustellintie 2  
15150 Lahti, FINLAND

This Declaration of conformity is issued under the sole responsibility of the manufacturer.

Objects of the Declaration:

Trade name of Electrical Medical Device:	Product code(s):
Practico	100030000, 145000
Promerix	100060000
Merimote	100060860
OpenOR™	200040100, 200040101, 200040102, 200040103 200041000, 200041001, 200042000 200040010, 200040020, 200043000
Q-Flow	520210, 520220, 520222, 520230, 520211 (incl. Camera option)

The objects of the declaration described above are in conformity of Directive 2011/65/EU of the European Parliament and of the Council of 8 June 2011 on the Restriction of the use of certain Hazardous Substances (RoHS) in electrical and electronic equipment. Conformity is declared based on harmonized standard:

EN 50581:2012                      Technical documentation for the assessment of electrical and electronic products with respect to the restriction of hazardous substances

Signed for and on behalf of Merivaara Corp.:

Lahti 21<sup>st</sup> of August 2019

  
\_\_\_\_\_  
Jari Kalja, Chief Executive Officer

# MANAGEMENT SYSTEM CERTIFICATE

Certificate No:  
66582-2009-AQ-FIN-FINAS

Initial certification date:  
13 May 1998

Valid:  
23 August 2018 - 31 December 2021

This is to certify that the management system of

**Merivaara Corp.**  
Puustellintie 2, 15150 Lahti, Finland

has been found to conform to the Management System standards:  
**ISO 9001:2015/ ISO 13485:2016**

This certificate is valid for the following scope:  
**Design, manufacture and sales of medical furniture and equipment.**

Place and date:  
Espoo, 23 August 2018



For the issuing office:  
DNV GL Business Assurance Finland Oy Ab

**Kimmo Haarala**  
Management Representative

# MANAGEMENT SYSTEM CERTIFICATE

Certificate No:  
66844-2009-AE-FIN-FINAS

Initial certification date:  
08 November 2000

Valid:  
23 August 2018 - 31 December 2021

This is to certify that the management system of

**Merivaara Corp.**  
Puustellintie 2, 15150 Lahti, Finland

has been found to conform to the Environmental Management System standard:  
**ISO 14001:2015**

This certificate is valid for the following scope:  
**Design, manufacture and sales of medical furniture and equipment.**

Place and date:  
**Espoo, 23 August 2018**



For the issuing office:  
**DNV GL Business Assurance Finland Oy Ab**

  
**Kimmo Haarala**  
Management Representative

# Q-FLOW

## New era in surgical lights

Merivaara Q-Flow™ surgical light improves the working environment in operating rooms as well as offers a new way to reduce the risk of infections.

Designed and manufactured in Finland, Q-Flow™ is the light of choice for any surgical team.



**OPTIMISED FOR THE OPERATING ROOM**

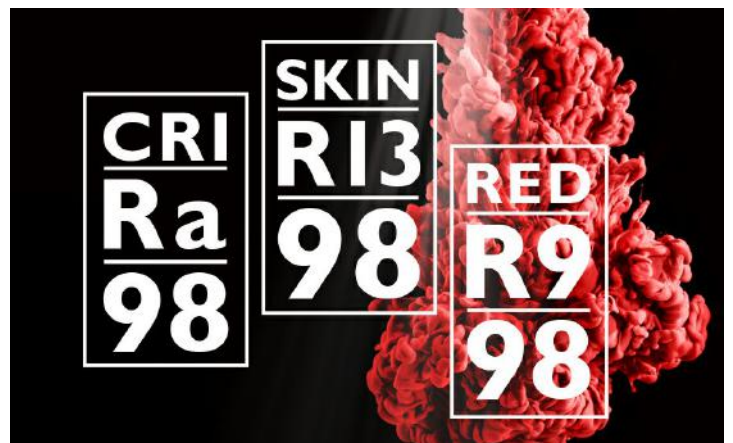

**SUPERB COLOUR RENDERING**



## AIR FLOW

Q-Flow™ is the intelligent solution for any operating theatre.

The design is optimised for the operating room air flow, because it decreases the air flow circulation in the operating area, thus reducing the potential for contamination. The standard turbulence intensity should be below 37.5 % but the Q-Flow boasts 15.9 % according to the DIN 1946-4:2008 standard.



## INTUITIVE STERILE SURGEON CONTROL (INTUERI™)

Intuitive Sterile Surgeon Control (Intueri™) makes surgical operations safer and the OR environment more ergonomic for surgeons. The user interface design is simplicity itself – anyone can use it.



## DYNAMIC OBSTACLE COMPENSATION (DOC™)

Dynamic Obstacle Compensation (DOC™) of Q-Flow™ automatically adapts to the shadows in the light field.

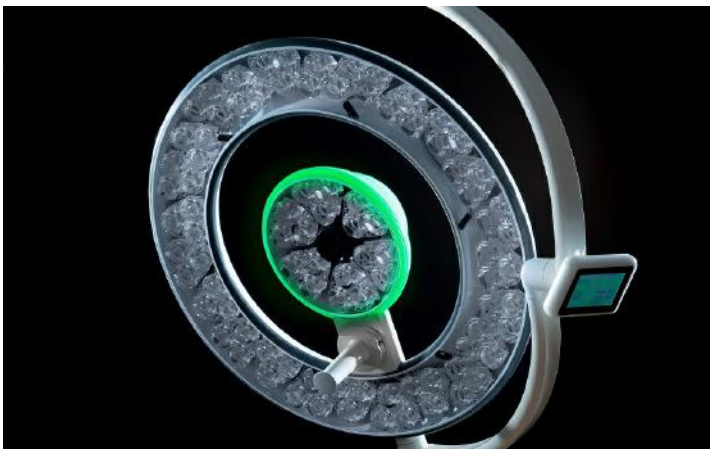

## GREEN AMBILITE

Q-Flow™ has excellent illumination properties, providing a deep column of light – not forgetting green ambilite, delivering consistent light for seeing images and reading monitors.



## FULL HD CAMERA

Q-Flow™ system with Full HD Camera provides excellent video stream quality. Integrated camera is controlled via same intuitive user interface as the light itself. Wireless transmission enables live video feed to external monitors e.g. in training or consulting.



reddot award 2017  
winner

FENNIAPRIZE 17  
GRAND PRIX

## **SUPERIOR LIGHTING WHERE YOU NEED IT**

Q-Flow™ Mobile is an intelligent and easily maneuverable solution for any operating room. Integrated battery and functional design provide outstanding flexibility.

**REDDOT 2017 WINNER &  
FENNIA PRIZE 2017 GRAND PRIX WINNER**

## Q-Flow™ surgical light features in a nutshell:

- Optimised for an OR's air flow (Q-OptiFlow™)
- Dynamic Obstacle Compensation (DOC™)
- Intuitive Sterile Surgeon Control (Intueri™)
- Excellent colour rendering
- Green ambilight
- Intuitive User Interface
- Deep column of light
- Wireless full HD Camera

Surgical light Q-Flow™ can be controlled through OpenOR integrated operating room management system and/or through multifunctional remote control Merimote™.

Title	Q-Flow 4	Q-Flow 4i	Q-Flow 6	Q-Flow 6i
Primary voltage	100 - 240 V	100 - 240 V	100 - 240 V	100 - 240 V
Secondary voltage	24 V	24 V	24 V	24 V
Illumination intensity E <sub>c</sub> at 1m distance	140000 lx	140000 lx	160000 lx	160000 lx
Depth of illumination, @ 20%	1500 mm	1500 mm	1800 mm	1800 mm
Depth of illumination, @ 60%	690 mm	690 mm	1200 mm	1200 mm
Colour temperature	3700/4400/5100 K	3700/4400/5100 K	3700/4400/5100 K	3700/4400/5100 K
Light field	200 - 320 mm	200 - 320 mm	200 - 370 mm	200 - 370 mm
Light field diameter, value d10	270 mm	270 mm	330 mm	330 mm
Light field diameter, value d50	150 mm	150 mm	190 mm	190 mm
Working distance	650 - 1700 mm	650 - 1700 mm	700 - 1800 mm	700 - 1800 mm
Colour rendering index (Ra)	98	98	98	98
Red colour rendering index (R9)	98	98	98	98
Number of LEDs	69	69	90	90
Average life time of LED	>50 000 h	>50 000 h	>50 000 h	>50 000 h
Size of light head	560 mm	560 mm	700 mm	700 mm
Weight of luminaire	13 kg	13 kg	16 kg	16 kg
Skin colour rendering index (R13)	98	98	98	98
Integrated dimming (%)	10 - 100 %	10 - 100 %	10 - 100 %	10 - 100 %
Turbulence intensity, DIN 1946 (%)	35 %	35 %	15.9 %	15.9 %
Power consumption (W)	60	60	100	100
Product Code	520210, 520220, 520222, 520230	520210, 520220, 520222, 520230	520210, 520220, 520222, 520230	520210, 520220, 520222, 520230

# Q-FLOW

## Surgical lighting system



Type: **Installation and maintenance instructions**

Document: **DO1140.en**

First release: 28.1.2016

Version: 1-9 17.5.2019



**Merivaara Corp.**

Puustellintie 2, FI - 15150 LAHTI, FINLAND  
Tel. +358 3 3394 611 • Fax +358 3 3394 6144  
merivaara@merivaara.com

[www.merivaara.com](http://www.merivaara.com)



<b>1</b>	<b>GENERAL</b>	<b>5</b>
	1.1 Why choose Merivaara Q-FLOW	5
	1.2 Intended use	6
	1.3 Essential performance	6
	1.4 User identification	6
	1.5 Liability	7
<b>2</b>	<b>WARNING AND NOTES</b>	<b>8</b>
	2.1 Warning	8
	2.2 Caution	11
<b>3</b>	<b>INSTALLATION</b>	<b>12</b>
	3.1 Before installation	12
	3.2 Wall installation of the system	14
	3.3 Ceiling installation of the system	14
	3.3.1 Raw ceiling installation	14
	3.3.1.1 Fixing bracket for 1-3 PSU	16
	3.3.2 Raw ceiling installation with intermediate tube set	17
	3.3.3 Installing Q-Flow SOLO and Q-Flow DUO 320	18
	3.3.3.1 Installing the tube to the adapting flange (Q-Flow SOLO and Q-Flow DUO 320)	18
	3.3.3.2 Q-Flow SOLO and Q-Flow DUO 320 with reinforced ceiling flange	19
	3.3.3.3 Installation of the extension arms - Q-Flow SOLO and Q-Flow DUO 320	19
	3.4 Q-Flow DUO - 3 point fixing	20
	3.4.1 Installing the ceiling tube assembly	20
	3.4.2 Preparing the ceiling tube	20
	3.4.3 Locking of the ceiling tube with the groove pin	21
	3.4.4 Secure the ceiling tube with clamping rings	21
	3.4.5 Installing extension arms and protective hood	22
	3.5 Power supply unit (PSU, for all models)	23
	3.5.1 Replacing fuses	24
	3.6 Installing the Q-Flow - 6 point fixing	25
	3.6.1 Ceiling tube D110 with welded flange - Q-Flow DUO and Q-Flow TRIO	26
	3.6.2 Installing extension arms to the ceiling tube D110 - Q-Flow DUO and Q-Flow TRIO	26
	3.6.3 Installing the protective hood D600	27

<b>3.7</b>	<b>Installing the balance arms - Q-Flow SOLO, DUO and TRIO</b>	<b>28</b>
3.7.1	Dismantling the circlip (Lock ring) from the balance arm	29
3.7.2	Balance arm adjustments (5202005)	30
3.7.2.1	Movement range of balance arm (5202005)	31
3.7.3	Low ceiling height versions of balance arms (LCH)	31
3.7.3.1	LCH (5202006) type balance arm installation with the Q-Flow	32
<b>3.8</b>	<b>Adjustment of the extension arm brake force</b>	<b>33</b>
<b>3.9</b>	<b>Installation of the Q-Flow luminaires</b>	<b>33</b>
<b>3.10</b>	<b>Installation of the Q-Flow mobile</b>	<b>34</b>
3.10.1	Contents of the Q-Flow mobile luminaire sub assembly	34
3.10.2	Fixing parts and required tools for the assembly	34
3.10.3	Installing the lower and upper vertical tubes	35
3.10.4	Installing the balance arm	36
3.10.5	Installing the luminaire	37
3.10.6	Preparing the Q-Flow mobile ready for use	38
3.10.7	Installation inspection	38
<b>3.11</b>	<b>Q-Flow luminaire with wireless HD camera module (optional)</b>	<b>39</b>
3.11.1	Installing the system containing camera and monitor	39
3.11.2	Installing the RF unit	39
3.11.3	Removing the camera	43
3.11.4	Installing the camera	45
3.11.5	Installing the wall mounted control panel (optional)	47
<b>3.12</b>	<b>Definition of user interface icons</b>	<b>48</b>
<b>3.13</b>	<b>User interface of the Q-Flow luminaire</b>	<b>50</b>
3.13.1	Starting the use	50
3.13.2	Luminaire (lamp) menu	51
3.13.3	Camera menu	51
3.13.4	Settings menu	53
3.13.4.1	Changing the language of the user interface	53
3.13.4.2	Setup menu- Connected devices	54
3.13.4.3	Synchronizing/adding a lamp	54
3.13.4.4	Removing a lamp	56
3.13.5	Pairing the camera with the network	57
3.13.6	Starting the diagnostic test	58
3.13.7	Resetting the lamp and camera counter	60
<b>4</b>	<b>CLEANING</b>	<b>61</b>
4.1	Covering front glass of the luminaire	61
4.2	Luminaire cleaning	61
4.3	Disinfecting	61
4.4	Sterilization	61

<b>5</b>	<b>MAINTENANCE AND REPAIR</b>	<b>62</b>
	<b>5.1 Preventative maintenance</b>	<b>62</b>
	<b>5.2 Daily maintenance</b>	<b>62</b>
	5.2.1 Annual maintenance	62
	<b>5.3 Troubleshooting</b>	<b>62</b>
<b>6</b>	<b>TECHNICAL DATA</b>	<b>65</b>
	<b>6.1 Identification plate</b>	<b>64</b>
	6.1.1 Labelling and symbols used on the product	66
	6.1.2 Packaging labels	67
	<b>6.2 Specifications</b>	<b>68</b>
	6.2.1 Environmental Conditions	68
	6.2.2 Classification data	68
	6.2.3 Surface materials	69
	6.2.4 Load data	69
	6.2.5 Luminaire specifications	71
	6.2.6 RF Unit specifications	74
	6.2.7 Electrical specifications of HD camera module (option)	74
	6.2.8 Technical specifications of HD camera	75
	<b>6.3 Dimensioning and connection diagrams</b>	<b>76</b>
	6.3.1 Q-Flow SOLO ceiling mounted system	77
	6.3.1.1 Connection diagram - Q-Flow SOLO lighting systems	78
	6.3.2 Q-Flow SOLO ceiling mounted monitor	79
	6.3.3 Q-Flow DUO ceiling mounted system	80
	6.3.3.1 Q-Flow DUO 360	81
	6.3.3.2 Q-Flow DUO 320 ceiling mounted system	82
	6.3.3.3 Q-Flow DUO - Low ceiling height system	83
	6.3.3.4 Connection diagram - Q-Flow DUO and Q-Flow TRIO lighting systems	84
	6.3.4 Q-Flow TRIO ceiling mounted system	85
	6.3.5 Connection diagram - Q-Flow SOLO, DUO and TRIO ceiling mounted systems with a battery backup unit BBU (option)	86
	6.3.6 Weights of the Q-Flow system components	87
<b>7</b>	<b>RECYCLING</b>	<b>88</b>
	<b>7.1 Metals and plastics</b>	<b>88</b>
<b>8</b>	<b>USER GUIDANCE FOR EMC</b>	<b>89</b>
	<b>8.1 Guidance and manufacturer's declaration - electromagnetic immunity and emissions</b>	<b>90</b>
	<b>NOTES</b>	

# 1. GENERAL

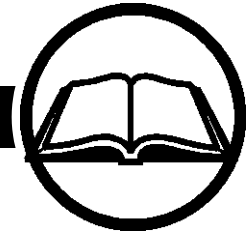

Read these instructions carefully to ensure safe and trouble-free operation of the Q-Flow™ luminaire. This user manual is regarded as a part of the product. Keep the user manual near the product for further reference. When installing additional equipment into the system, supplement these instructions with the user instructions that came with the additional equipment.

The EN 60601-2-41 standard has been applied in the structural design of the Q-Flow system and luminaires. The device is classified as belonging to product category I according to the directive 93/42/EEC (MDD) including amending directive 2007/47/EC, and thus has a CE marking. This product contains a wireless radio equipment and conforms to Radio Equipment Directive (RED) 2014/53/EU.

## 1.1 Why Merivaara Q-FLOW

- Compatibility towards laminar air flow
- Intuitive sterile controls for the surgeon (Intueri™)
- Dynamic obstacle compensation (DOC™)
- Excellent colour rendering properties
- Improved hygienic properties
- Deep stabilized column of light
- Intuitive touch controls

### Health technology with a human touch

Merivaara provides a wide range of hospital-grade furniture such as operating tables, medical lights, examination tables, trolleys and stretchers for transportation and day surgery, as well as birthing and patient beds. Additionally, our offering includes also revolutionary integrated OR management systems.

We believe that technology in critical operations such as surgery has to work seamlessly together and still be easy to use. Our operating room solutions aim to make procedures more fluent and comfortable which, in turn, leads to concentration, confidence and better co-operation within the surgical team.

Established in 1901, Merivaara has more than 115 years of experience in designing and manufacturing hospital-grade furniture. Today our products are highly appreciated by users in more than 120 countries thanks to their ease-of use, durability and ergonomic design.

Merivaara's medical products are CE-labelled as the company's quality management system complies with EU directives for medical device. It is certified by DNV according to ISO 9001 and ISO 13485 standards. The company's environmental management system is ISO 14001:2004 certified. Read more at [www.merivaara.com](http://www.merivaara.com).

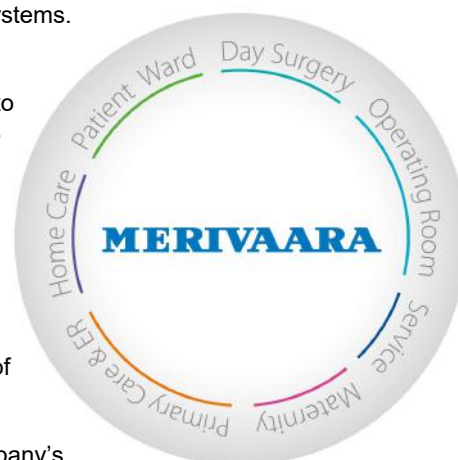



## 1.2 Intended use

The Q-Flow surgical lighting system contains modern operating room luminaires which are intended to be used in hospitals and health care centres. The luminaires are suitable for use during examinations and surgical operations with high illumination requirements. The HD camera is intended for transferring the image and helping the operation room personnel to follow up surgeries. The camera is not intended for diagnostic use.

## 1.3 Essential performance

The essential performance of Q-Flow surgical lights and lighting system is the delivery of illumination and the limitation of energy to the operating field. Produced total irradiance and illumination intensity of one luminaire is  $<1000 \text{ W/m}^2 / 160\,000 \text{ Ec}$  at 1m distance (lx). Complete technical details are presented in chapter 6. TECHNICAL DATA on page 66.

## 1.4 User identification

Merivaara's Q-Flow system and these operating instructions are intended to be used by medical personnel and qualified technicians working in hospitals, medical surgeries, or qualified legal agencies, who have acquired working skills by undergoing medical training and who are in possession of necessary authorisation where required.

Mandatory personnel training for the use of *Merivaara* Q-Flow system must be carried out. Make sure that the training of your personnel complies with the guidelines presented in the document no. T404474.

For your personal safety, read all safety precautions and warnings carefully in section 2. WARNINGS AND NOTES on page 8 before using the product.

The operations which associate with adjustments necessary during the installation must be performed by a qualified technician of the product owner operator in accordance with the safety rules and precautions indicated in this user manual.

In case of re-adjustments for the central axis or of its components, contact technical personnel immediately. Nursing staff or persons involved in treatment or surgical procedures are not intended to do these kind of procedures.

Product cleaning and disinfection can only be done by duly trained personnel according to the best practices used at the facility, strictly attended with the instructions given in this user manual.

Before use is strongly recommended to disinfect the whole system.

Disregarding the guidelines presented in this user manual can be interpreted as a user error and result in loss of product warranty.

## 1.5 Liability

The contents of this user manual may be amended by *Merivaara*, without prior notice or any further obligations, in order to make changes and improvements. The reproduction, including partial, or translation of any part of this manual is forbidden without a written permission of *Merivaara*.

*Merivaara* reserves the right to change, cancel or otherwise amend the data contained in this document at any time and for any reason without prior notice as much as *Merivaara* is constantly seeking new solutions which lead to product evolution. *Merivaara* therefore reserves the right to make changes to the supplied product in terms of shape, fittings, technology, and performances.

With regard to translations into languages other than English, reference is always made to the English edition of this operator's and user manual. For the best benefit to understanding the instructions, we suggest to read and look the corresponding pictures enclosed.

The system is delivered in pre-assembled modules, which the customer must assemble into a finished product. Check the contents of every package for any shipping damages. The corrugated board packaging is recyclable, whereas the plastics and styrofoam are energy waste.

On-site verification must be done by whoever is responsible for or is a holder of an office both at the public and private establishments of the *Merivaara* Q-Flow system.

*Merivaara* does not take responsibility of consequences if the system contains other suppliers material or components. All system parts must be tested according to EN 60601-1.





Copyright © 2019 *Merivaara* Corp. All rights reserved.

## 2. WARNINGS AND NOTES



### 2.1 Warning

All warnings and items to be noted in this installation and maintenance manual are specified as follows. Read them carefully!

-  **WARNING!** Observe to ensure user, maintenance personnel and patient safety.
-  **CAUTION!** Please observe in order to avoid causing damage to the equipment or its parts.
-  **WARNING!** Dangerous voltage! Improper installation or maintenance can cause electric shock.
-  **NOTE!** Please observe in order to improve Q-Flow properties.
-  **SERVICE!** Must be lubricated during installation and maintenance as well as when replacing parts.

-  **WARNING!** Always switch off the luminaire and the lighting system from the power mains, and make sure the system is on de-energized state before any maintenance or repair!

Maintenance allowed only to persons specialized and trained to *Merivaara* surgical lights service work.

Please read and understand the service policy and warranty terms clearly before performing any maintenance to *Merivaara* surgical lights!

In order to replace the Q-Flow parts, read carefully all instructions before start any operation especially which regards opening of the sealed cover or other inner parts of the luminaire. List of spare parts is available separately.

Make sure the sterilizable handle is installed in place before use.

Keep the camera and the RF receiver unit at a minimum distance of twenty (20) centimetres from the living tissue.

Do not modify the product during maintenance procedures.

If more than one luminaire is focused to the same illuminance spot, total irradiance and UV irradiance can increase over the permissible values.

Risk of ceiling tube dropping! A dropping ceiling tube can cause serious injuries. During the assembly, nobody is allowed to stand under the central axis!

High luminous intensity, do not look directly to the light source when operating, can cause dazzling effect.

Use luminaire metal yokes only for the pre-adjustments.

Connect power supply cord to earthed power supply only!

Device can be isolated from supply mains by detaching the power supply cord!

Static charges can cause sparks harming sensitive electronic components. Ground yourself to metallic parts before touching electronic components.

Use only spare parts acquired from *Merivaara Corp.* Use procedure number as a reference and check if the part is available as a spare part from the list.

Mark the lock ring (circlip) as a single-use item and keep it in a safe place for later mounting. Follow the instructions given in [3.7.1 Dismantling the circlip \(Lock ring\) from the balance arm on page 29](#).

If any parts are replaced, final testing must be performed before implementation.

Improper installation can cause electric shock and will void the warranty!

Copying of this document and giving it to others and the use or communication of the contents thereof are forbidden without express authority. Offenders are liable to the payment of damages. All rights are reserved by *Merivaara Corp.* in the event of the grant of a patent or the registration of a model or design.

The Q-Flow surgical lighting system must be equipped with a power supply backup system which prevents use interruptions if failure of power supply network occurs. A power supply backup system is not included with the system delivery.





To avoid the risk of electric shock, this equipment must only be connected to a mains supply with protective earth.

All rated values of illumination intensity are measured as a standard 1 m distance; however, the maximum illumination intensity is higher than rated values and it is measured from 1.3 m distance of the luminaire surface.

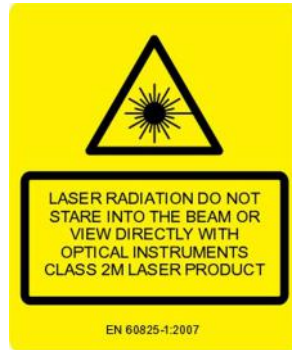
**LASER RADIATION! DO NOT STARE INTO BEAM OR VIEW DIRECTLY WITH OPTICAL INSTRUMENTS, CLASS 2M LASER PRODUCT!** The laser UI feature is only on the Q-Flow i-series!





 **WARNING!** When using the laser UI, keep the laser beam away from patient's and employee's eyes. Attention, danger of injury! If necessary, use laser safety glasses!

 **NOTE!** Activate the sterilizable focus handle Intueri™ controls with laser UI from the settings menu of the luminaire user interface.

 If the luminaire hits obstacles, the sterilizable focus handle or the touch screen may get broken. Always handle the luminaire with great care.

 Faulty device must not be used, set the luminaire out of use and contact service personnel.

 **WARNING!** During installation, ensure that no wires are pinched or otherwise damaged! A damaged wire can cause electrical shock! The system may only be installed by trained personnel!

 Faulty wiring must NOT be installed and defective products must not be used! Faulty wiring can cause electric shock!

 No user serviceable parts inside! Hazard of electric shock!

 Improper installation of the system can cause electric shock and will void the warranty!

## 2.2 Caution



### CAUTION!

If the system has been stored in a cold, damp place, it must be allowed to dry out in a heated room, preferably one full day before the installation and activation. Take care of the product by following the instructions on storage and transport presented on Chapter 6.2.1 Environmental Conditions on page 69.

If you use other supplier's components, e.g an other power supply with Q-Flow luminaires, please read the instructions carefully provided by the component supplier. *Merivaara* does not take responsibility of consequences if the system contains other supplier's material or components. Every system parts must be tested according to EN 60601-1.

Improper installation of the RF receiver unit may result in disturbances in the image quality of the camera.

Other electrical equipment should not be installed adjacent to the power supply unit. If multiple power supply units are mounted, they must not be stacked.

Ground all of the monitor bracket arm joint parts together in series and attach the grounding leads to the sleeve of the ceiling flange.

The protective plastic covering of the luminaire must not be removed until after the final construction clean-up.

The system may only be installed by an qualified technician with the required licenses and qualifications! Improper installation can cause electric shock and will void the warranty!

## 3. INSTALLATION

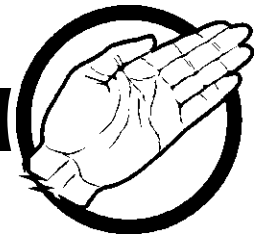

### 3.1 Before installation

 **WARNING!** Remember to perform all annual maintenance measures to the system and train your service team according to the document: T404474.

 **WARNING!** The system may only be installed by an qualified technician with the required licenses and qualifications! Improper installation can cause electric shock and will void the warranty!

During the concrete pouring stage, wedge anchors or threaded rods with screw anchors must be installed to the ceiling in accordance of the instructions given in the *Q-Flow Site Preparation Manual T404230*. If the system is installed into a ceiling that does not have fixings (post-installation), holes for supplied wedge anchors has to be drilled.

Any illustrations of concrete ceiling structures and the wedge anchors in this manual are presented in order to bring the installation of the ceiling flange and its substructures to a complete product. All technical information concerning the wedge anchors and concrete ceiling preparation are defined in the *Q-Flow Site Preparation Manual T404230*.

Definitions of the electrical requirements of the installation site for the Q-Flow system installation have been defined also in the *Q-Flow Site Preparation Manual T404230*. Please complement your knowledge by reading this Q-Flow Installation and maintenance manual thoroughly.

Professional engineer of a trusted party which is duly registered with the professional register must ensure the structural strength of the ceiling before the installation can be done. Installation must also comply with the local regulations, building codes and standards. Fill in the *Ceiling installation sign off document no. T404360* and archive it.

Separate Q-Flow inspection forms for the installation and maintenance are presented in documents: T404338 and T404339. Make sure the measures given are followed.

 **WARNING!** When the system is in de-energized state, make sure that the mains power cannot be switched on accidentally during the installation.

 **WARNING!** Before continuing the Q-Flow system installation presented in this manual, make sure the site preparation instructions given are strictly followed.

 **WARNING!** Because of the risk of the system or its part dropping during the installation, nobody is allowed to stand under the ceiling tube or its substructures.

 **WARNING!** If not installed properly, the ceiling flange mounting may fail and the whole Q-Flow system might fall.

 **WARNING!** The moment of the long extension arm places a stress on the ceiling tubes that is greater than the weight of the luminaire, and because of this, the installation of the system must be performed carefully.

 **WARNING!** Ensure that you have all the specified components and the supplies included with them which you can identify with these instructions at hand. Also ensure that all components are intact and fully functional!

 **WARNING!** Following carefully the instructions presented in this manual you can ensure that the system is properly installed and fully operational.

 **WARNING!** When ordering the system, height of the concrete ceiling must be indicated, because the ceiling tube measures are defined in accordance with the height of the installation site.

This Installation and maintenance manual refers to the intermediate tube set and interface plate provided by *Merivaara Corporation*. If the intermediate tube set or flange assembly provided by Merivaara cannot be installed, re-engineered solution can be used. However, note that in this case it will be done at own risk.

*Merivaara* does not accept any legal responsibility for the inappropriate installation or corrupted material or faulty structure of the ceiling.

 **NOTE!** The Q-Flow system installation inspection must be done according to the T404338.

 **NOTE!** Optionally, the power supply unit can be installed with an isolating transformer into the technical space, at the maximum distance of 15 meters measured from the central axis cabling connections. This applies also to cases in which a UPS with a back-up battery are used. General electrical requirements are specified in the document *Q-Flow Site Preparation Manual T404230*.

 **NOTE!** Merivaara recommends to use primary and secondary wiring at least 2.5 mm<sup>2</sup> cables, e.g. MMJ 3 x 2.5 mm<sup>2</sup> or MPLM 3 x 2.5 mm<sup>2</sup>.

 **WARNING!** The electrical connections of the Q-Flow PSU are indicated in the *Picture 7. Dimensions and connections of the power supply unit (PSU) on page 23.*

 **WARNING!** Merivaara Q-Flow surgical lighting system must be installed primarily using the 6 point fixing, Use the 3 point fixing only for a specific model with a triangular ceiling flange.



## 3.2 Wall installation of the system

When installing the Q-Flow to the wall with the wall bearing (code 5202003), follow the manufacturer's instructions, which are delivered with the wall bearing (refer to "*Ondal Installation instructions ACROBAT 77/2000*

*Wall bearing*").



**WARNING!** Requirements concerning the wedge anchors and the site preparation procedure before the installation is presented in the *Q-Flow Site preparation manual, document number T404230*.

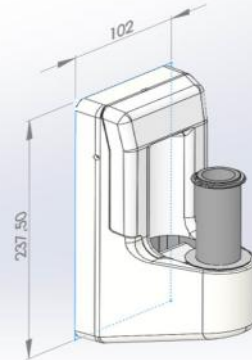

## 3.3 Ceiling installation of the system

### 3.3.1 Raw ceiling installation



**WARNING!** Before starting the installation, the structural engineer must sign off the *Q-Flow Ceiling Flange installation Sign Off document T404360*. This document must be archived by the Q-FLOW light installing party.

After the installation site is prepared according to the instructions of the *Q-Flow Site Preparation Manual T404230*, the system can be installed to the superstructure of the installation site by following the steps presented below (the numbers in brackets refer to the *Picture 1. Installing the ceiling tube with the M16 fixing set on page 15.*) At least this fixing method must be used.

1. Prepare the interface plate and the actual ceiling flange assembly carefully before the final installation.
2. Install the ceiling tube (1) with welded flange (2) at a maximum distance of 275 mm of the surface of the interface plate (3 and 4).
3. Cut the M16 threaded rods for even spacing and check that there is also enough space to level the ceiling tube straight.
4. Install the M16 threaded rods (5) ,6 pcs) around the base circle of 270 mm close to actual flange (interface plate) inner cutout. Make sure the rod ends are collinear with the ceiling flange backside edge. Tighten the rods with M16 nuts and washers to the torque of 195 Nm.
5. Ensure that there is enough space to duct the cabling which is fed through from the ceiling tube.

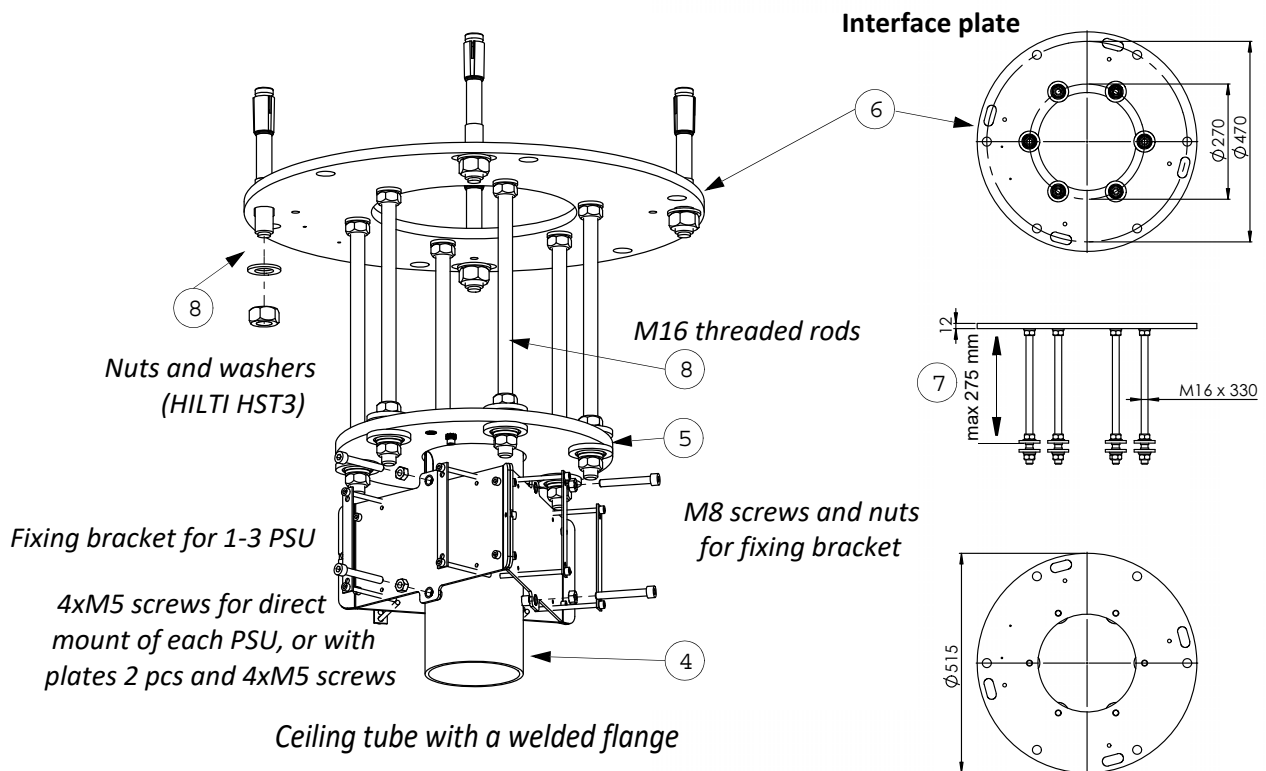

Picture 1. Installing the ceiling tube with the M16 fixing set

6. Install the M16 nuts against the insulation washer set from both sides of the ceiling tube with a welded flange to the torque of 100 Nm.

7. Fix the interface plate assembly flush to the raw ceiling with supplied M20 nuts 4 pcs and washers 4 pcs (5). Tighten the nuts to the torque of 240 Nm. Note that there are four (4) contoured mounting holes on the flange (interface plate) for an easy installation.

8. Use a spirit level to check the ceiling tube straightness.

**WARNING!** Requirements concerning the wedge anchors and the site preparation procedure before the installation is presented in the *Q-Flow Site preparation manual, document number T404230*.

**NOTE!** The 3-point fixing is only allowed on the triangular flange of the Q-Flow DUO with the D70 ceiling tube.

### 3.3.1.1 Fixing bracket for 1-3 PSU

An optional fixing bracket part no. A43404700 installation for the 1 to 3 pcs power supply units can be done by stringing the bracket onto the ceiling tube.

1. Prepare the bracket and the cabling of the power supply units to be ready for the installation.
2. Take a close look to the PSU unit installation in chapter 3.5 Power supply unit (PSU, for all models) on page 23.
3. Direct mount the Q-Flow luminaire PSU with 4 pcs of M5 screws to the bracket plate.
3. There are alternative 2 pcs of securing plates for the PSU units for the use of other end devices such as displays and monitors. In such cases, tighten the plates towards the PSU frame with M5X75 ZN SFS2219 screws.
4. Install the bracket assembly to the ceiling tube with 6 pcs M8X60 ZN SFS 2219 screws and secure it with M8 SFS 2067 nuts (6 pcs).



**WARNING!** Requirements concerning the environmental conditions and general requirements of the Q-Flow power supply unit have been specified in the *Q-Flow Site Preparation Manual T404230*.



**WARNING!** There may be limitations in this kind of PSU arrangement; if the power supply unit installation cannot be safely covered with the protective hoods supplied, or sufficient ventilation cannot be guaranteed, alternative options must be considered before the system installation!

### 3.3.2 Raw ceiling installation with intermediate tube set

The intermediate tube set is used with the intermediate ceiling structures (dropped ceiling/false ceiling) to ensure the firm installation of any Q-Flow system.

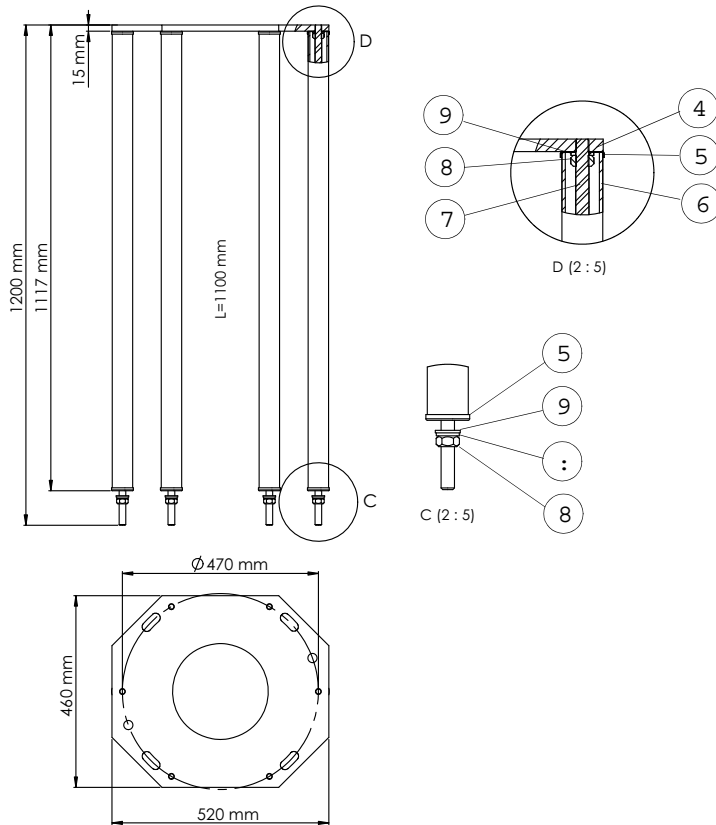

#### Intermediate tube set:

- (1.), Ceiling flange 1 pcs
- (2.), Metal fixing disk 12 pcs
- (3.), Intermediate tube 6 pcs
- (4.), M16 threaded rods 6 pcs
- (5.), M16 nuts 12 pcs
- (6.), M16 washers 6 pcs
- (7.), M16 spring washers 12 pcs

#### Interface plate fixing set:

- M16 nuts 13 pcs
- M16 washers 7 pcs
- M16 spring washers 13 pcs
- Fixing discs 13 pcs

Picture 2. Intermediate tube set for raw ceiling installation

1. After the installation site is prepared according to the instructions in the *Q-Flow Site Preparation Manual T404230*, the system can be installed to the superstructure of the installation site.
2. Measure the M16 threaded rods to the correct installation length. Install the rods (6 pcs) around the hexagonal plate base circle of 470 mm. Make sure the rod ends are collinear with the ceiling flange backside edge. Tighten the rods with M16 nuts and washers to the torque of 195 Nm.
3. Cut the intermediate tubes 6 pcs to fit the space located between the raw ceiling and the intermediate ceiling. Fixing disks are installed directly after of the tube ends on both sides.
4. Prepare the interface plate with a fixing set prior to complete the intermediate tube set.
5. Install the intermediate tubes with threaded rods between the plates. Metal fixing disks are intended to hold the intermediate tubes in place to mount the interface plate towards the tubes. Tighten the M16 nuts and washers to the torque of 195 Nm. Please take a look to the details C and D in the picture above.

6. Go through the steps presented in the previous section for the installation of the Interface plate and the ceiling tube assembly. A supplied fixing set includes all parts needed for the firm installation.
7. Install the intermediate tube set with the flanges (base plate and the interface plate) flush to raw ceiling!
8. Install and set the medium duty or light duty ceiling tube after these steps by following the forthcoming sections.

### 3.3.3 Installing Q-Flow SOLO and Q-Flow DUO 320

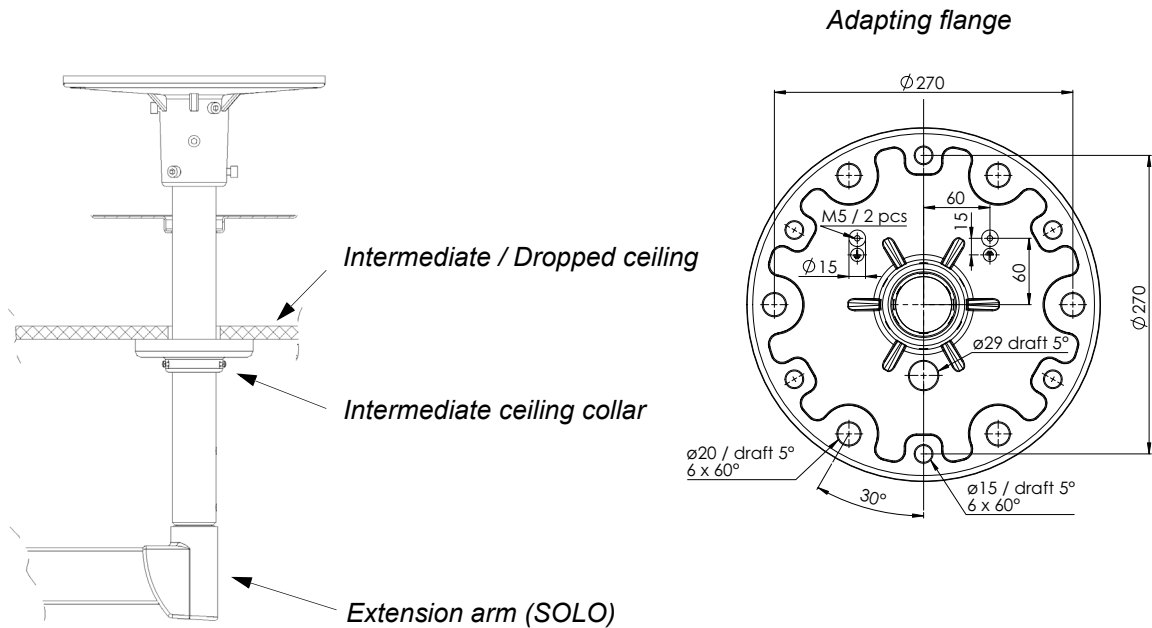

Picture 3. A ceiling tube D50 with a adapting flange assembly

**WARNING!** Requirements concerning the wedge anchors and the site preparation procedure before the installation is presented in the *Q-Flow Site preparation manual*, document number T404230.

#### 3.3.3.1 Installing the tube to the adapting flange (Q-Flow SOLO and Q-Flow DUO 320)

1. Remove the screw (1) and nut/washer (2) from the adapting flange (3).
2. Loosen the screws (4) such a way they are almost off (6 pcs of screws).
3. Place the tube (5) inside the flange base (3) and attach it with the fixing parts (1) and (2).
4. Tighten the screws (4) and position the tube vertically by using a spirit level (6).
5. Connect the cables coming from the tube cutout (7) to the connection strip (8).
6. After the ceiling tube has been installed to the adapting flange, follow the instructions presented in the sections 3.2.1 and 3.2.2.
7. Connect the wires from the PSU to the connection strip (8), and the yellow-green (GND/PE) wire under the earthing screw.
8. Install the protective hood (10) and secure it with screws (11) 3 pcs nuts 3 pcs.

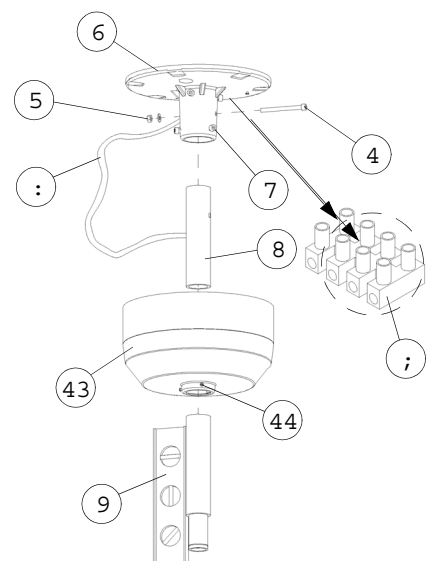

**!** **NOTE!** Check the length of the ceiling tube during the procedure. Recommended measure of the tube end is about 2.25–2.35 m from the floor.

### 3.3.3.2 Q-Flow SOLO and Q-Flow DUO 320 with reinforced ceiling flange

This type of reinforced ceiling tube with a welded flange can be used for the light duty systems if the raw ceiling height is over 4.4 m. It can be also replaced by using a intermediate tube set.

1. Open the screws (1) and (2) so that the screws are almost off (6 pcs).
2. Place the ceiling tube (3) into the ceiling flange (4) and tighten with screws (1).
3. Tighten screws (2) and position the tube vertically by using a spirit level (5).
4. Connect the cable (6) to the connector strip (7).
5. Connect the wires of the transformer to the serial connector (7) and the yellow-green wire under the earthing screw.
6. Install the protective hood (8) and fix it with the fixing collar (9).

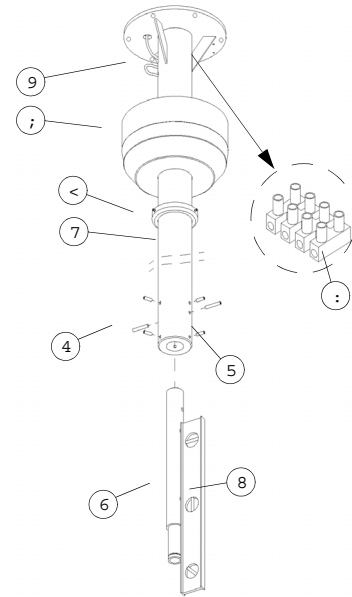

### 3.3.3.3 Installation of the extension arms - Q-Flow SOLO and Q-Flow DUO 320



1. Remove the lock ring (1) and the washer (2) from the ceiling tube.
  - **SERVICE!** Grease the sliding surfaces of the ceiling tube axis and the extension arm.
2. Lift the extension arm (3) into place and attach the washer (2) with a clip and lock ring (1).
3. Carefully install the male half of the electric coupling (4) with the female half located inside the ceiling arm.
4. Attach the protective end covers (5 and 6).
  - Special circlip pliers needed! Pliers must be set a 8 mm strut limitation to prevent deforming or over stretching the lock ring (circlip).

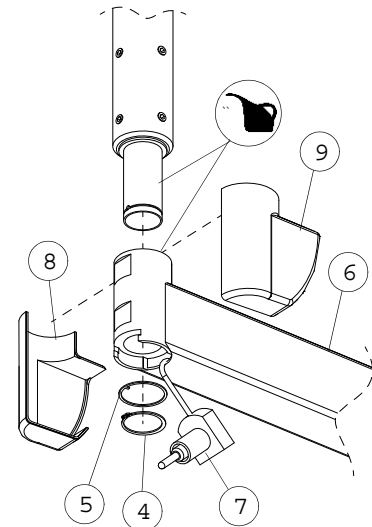

**!** **CAUTION!** INSTALL THE PART 4 CAREFULLY AND ENSURE THAT THE PART 1 IS SECURELY LOCKED INTO PLACE.

**!** **WARNING!** Risk of system or its parts dropping, if the installation is made carelessly. Pay a special attention when installing parts no. (1) and (2).

### 3.4 Q-Flow DUO - 3 point fixing

This model uses a special ceiling flange with 3 point fixing. Always install the ceiling tube D70 with a ceiling flange assembly to the intermediate tube set by using an interface plate with a fixing set as presented in chapter on page 14, then follow the instructions presented in this chapter.

 **WARNING!** Requirements concerning the wedge anchors and the site preparation procedure before the installation is presented in the Q-Flow Site preparation manual, document number T404230.

#### 3.4.1 Installing the ceiling tube assembly

Prepare the assembly by cutting the ceiling tube to proper length matching it with the intermediate tubes and the interface plate assembly. Follow the dimensioning of the ceiling flange as presented below.

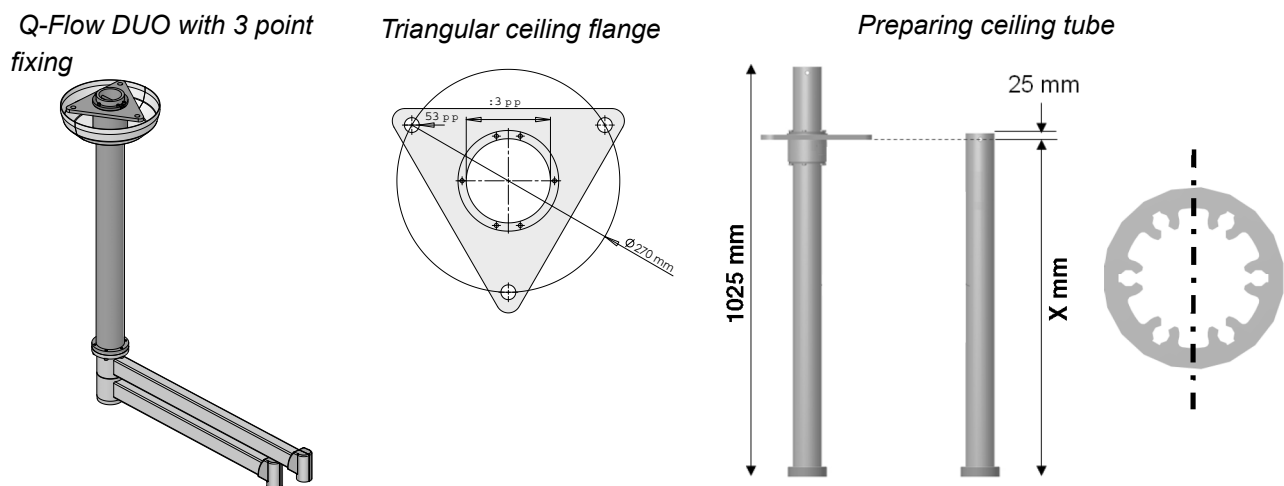

Picture 4. Dimensioning of the ceiling flange

#### 3.4.2 Preparing the ceiling tube

1. Place a drill hole at the calculated distance X as indicated in Picture 4. Dimensioning of the ceiling flange on page 20. The distance is measured from the lower edge of the adapting ceiling flange with a diameter of 10.2 mm.
2. Cut the tube to a length that the distance from the centre of the drill hole to the cutting edge is 25 mm. The maximum recommended length for the tube is 1000 mm.
3. Ensure that the hole is running through the ceiling tube cross-section in the middle (Refer to Picture 5. Locking of the ceiling tube with the groove pin on page 21.) Use the provided template for orientation purposes.
4. Deburr the cutting edges.

### 3.4.3 Locking of the ceiling tube with the groove pin

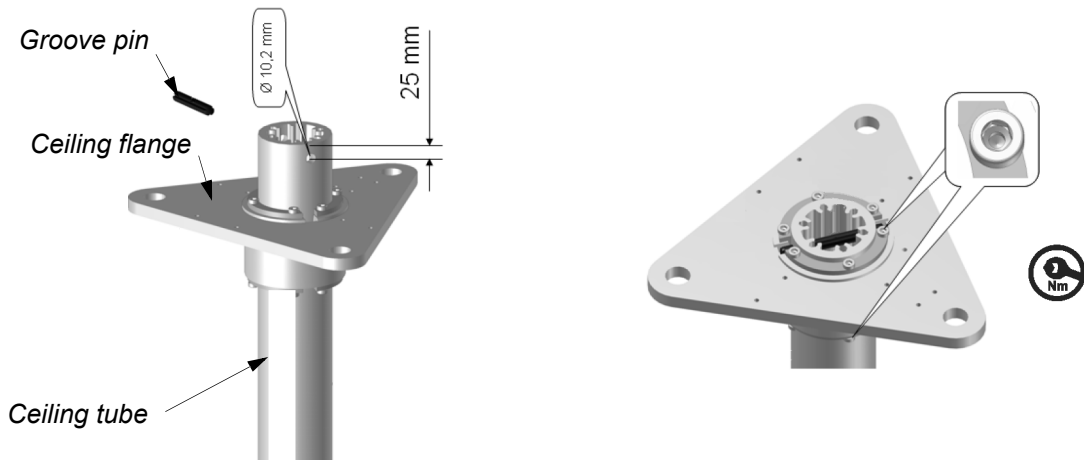

Picture 5. Locking of the ceiling tube with the groove pin

Bring the ceiling tube into the flange and insert the groove pin evenly through the two drill holes. Pull the ceiling tube back towards the top such a way that the groove pin is in the provided slot inside the flange.

### 3.4.4 Securing the ceiling tube with clamping rings

Secure the ceiling tube to the flange by using clamping rings.

Tighten the 3 screws on each of the 4 clamping rings with 10 Nm. Start with the screw which is in the middle. 2 clamping rings are already pre-assembled. Use the lower 2 clamping rings which are included in the accessory kit.

 **WARNING!** Risk of ceiling tube dropping! A dropping ceiling tube can cause serious injuries. During the assembly, nobody is allowed to stand under the Central Axis or its substructures!

 **CAUTION!** Make sure that the grooved pin remains visible in the slot. Check that the flange fits tightly.

 **WARNING!** Electric shock hazard! If the insulation is defective, the pendant system Central Axis system may be live. The Central Axis system must always be grounded! Connect the grounding wire with the grounding point next to the grounding sign of the ceiling flange plate!



### 3.4.4.1 Installing extension arms and protective hood

1. Run the supply cables through the ceiling tube before installing the extension arms. The length of the arms are 950 mm and 800 mm which is measured from vertical axis of one end axle to the other.
2. Place the cables carefully without effort through the flange with a ceiling tube. Position the central axis directly below the ceiling tube by using a suitable lifting device.



**WARNING!** Risk of Central Axis dropping! A crashing central axis can cause serious injuries.

3. Position the extension arms below the ceiling tube by using a suitable lifting device or e.g. holding the extension arms at installation height.
4. Feed the cables through the ceiling tube. Prevent the arms from rotating by using, for example by tying them with a zip tie.
5. Fix the extension arms in place with 6 pcs of supplied hex screws.
6. Tighten the hex screws with 20 Nm.

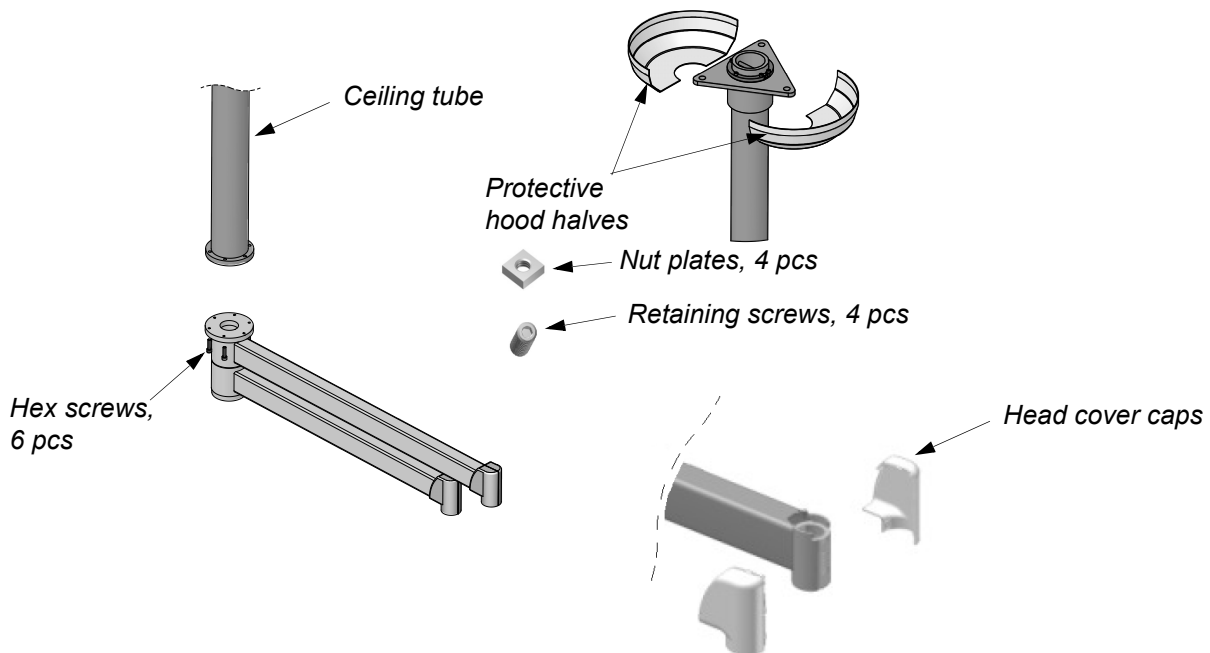

Picture 6. Installing extension arms and protective hood

7. Install the protective hood halves by pressing the covers together and fix with nut plates and retaining screws towards the intermediate ceiling.
  8. Secure the hood halves from outside collar with fixing screws supplied to the intermediate ceiling with the maximum of 0.2 Nm.
  9. Remove the extension arm head cover caps for balance arms installation.
  10. Loosen the clip-mechanism on the inside of the cover carefully by using a small screw driver.
- To install the balance arms, refer to [3.7 Installing the balance arms - Q-Flow SOLO, DUO, and TRIO](#) on page [28](#).

### 3.5 Power supply unit (PSU, for all models)

The power supply unit is recommend to be installed directly with the isolating transformer into the technical space, with a maximum distance of 15 meters, measured from the central axis connections. Follow the respective system connection diagram closely!

1. Connect the power supply unit (1) to the system as shown in the picture below.
2. Remove the protective cover (2) from the frame by opening fixing screws (3), 2 pcs.
3. Fix the protective case covers to the frame of supply board with levellers (4) and fixing screws (5) 4 pcs.
  - The diameter of PSU base plate external fixing grooves is 6 mm.
  - Terminal blocks (6) with fuse holders. Wire connections are marked clearly on to the side of each block.
  - Cable clamps (7) are located on both input and output sides. Each cable is clamped with screws (8), 2 pcs.
  - Ensure proper grounding of the power supply unit!

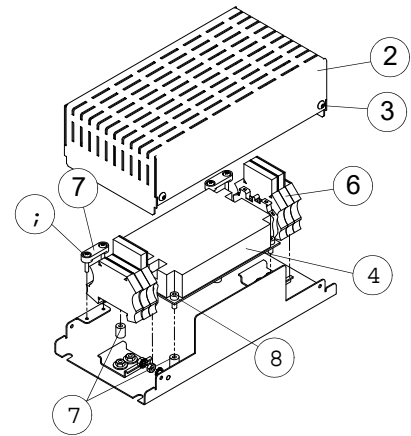

#### Dimensions and connections of PSU

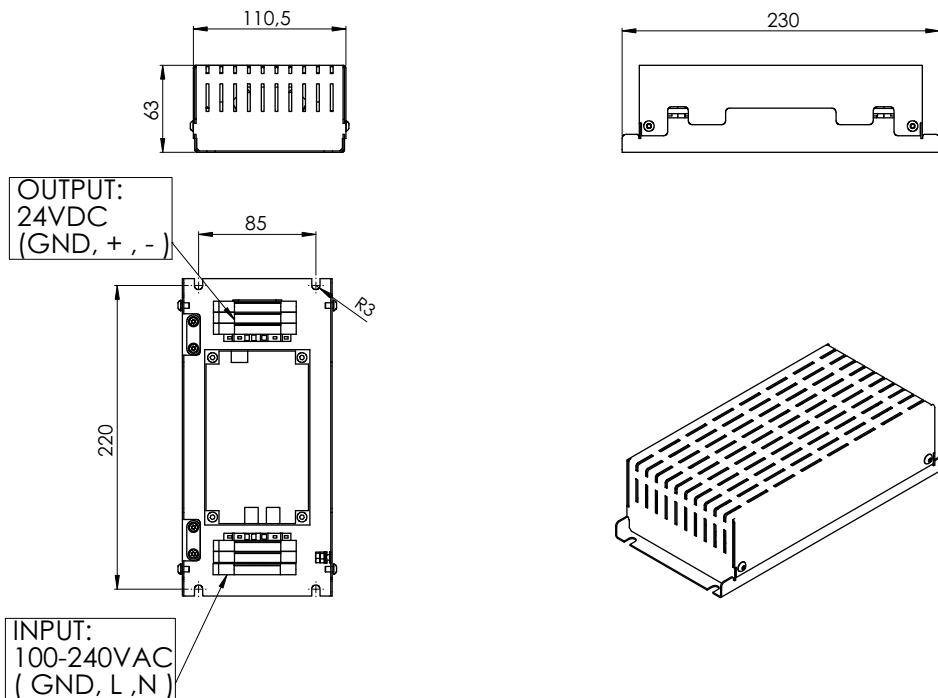

Picture 7. Dimensions and connections of the power supply unit (PSU)



**WARNING!** Always use the PSU type: EOS Power India, MWLP350. Accomplish the installation according to this installation and maintenance manual and ensure to comply it with the national regulations. The compliance of the installation must be verified against the *Q-Flow Site Preparation Manual T404230* by the licensed electrician.

### 3.5.1 Replacing fuses



**WARNING!** Always switch off the luminaire and the lighting system from the power mains, and ensure that the system is in a de-energized state before any maintenance or repair! Hazard of electrical shock!



**WARNING!** Maintenance is allowed only to persons who are specialized and trained for service of *Merivaara's* surgical lights.

#### **Mains fuses (power supply unit):**

Fuse type: glass fuse; Primary T2A H/250V, 1 pc and Secondary F6.3A L/250V, 2 pcs

1. Remove the protective cover fixing screws (2 pcs), and lift the cover off from the power supply unit base cover.
2. Flip the fuse holder (6) out which is located inside of the terminal block.
3. Detach the fuse by using a small screw driver and press its tip underneath of the fuse until the fuse pops up from the holder.
4. Press the new fuse(s) in place to the holder and assemble the power supply in reverse order as described.

#### **Luminaire fuses:**

Fuse type: surface mount fuses, F6.3A L/125V, 3 pcs

1. Remove the sterilizable focus handle from the luminaire.
2. Remove the handle release button: Turn the button counterclockwise with a 6 mm key.
3. Remove the frame cover plate screws 2 pcs and remove the plate.
4. Detach all 3 fuses from the fuse blocks located on the main PCB underneath of the cover plate with pointy-nose pliers, and replace all of them at once.
5. Assemble the luminaire parts in reverse order, spare parts. More detailed information available from Merivaara After sales or from your local dealer.

### 3.6 Installing the Q-Flow - 6 point fixing

The Q-Flow central axis is presented with a ceiling tube D110 with a welded flange in the pictures below.

**Central axis assembly with a interface plate**

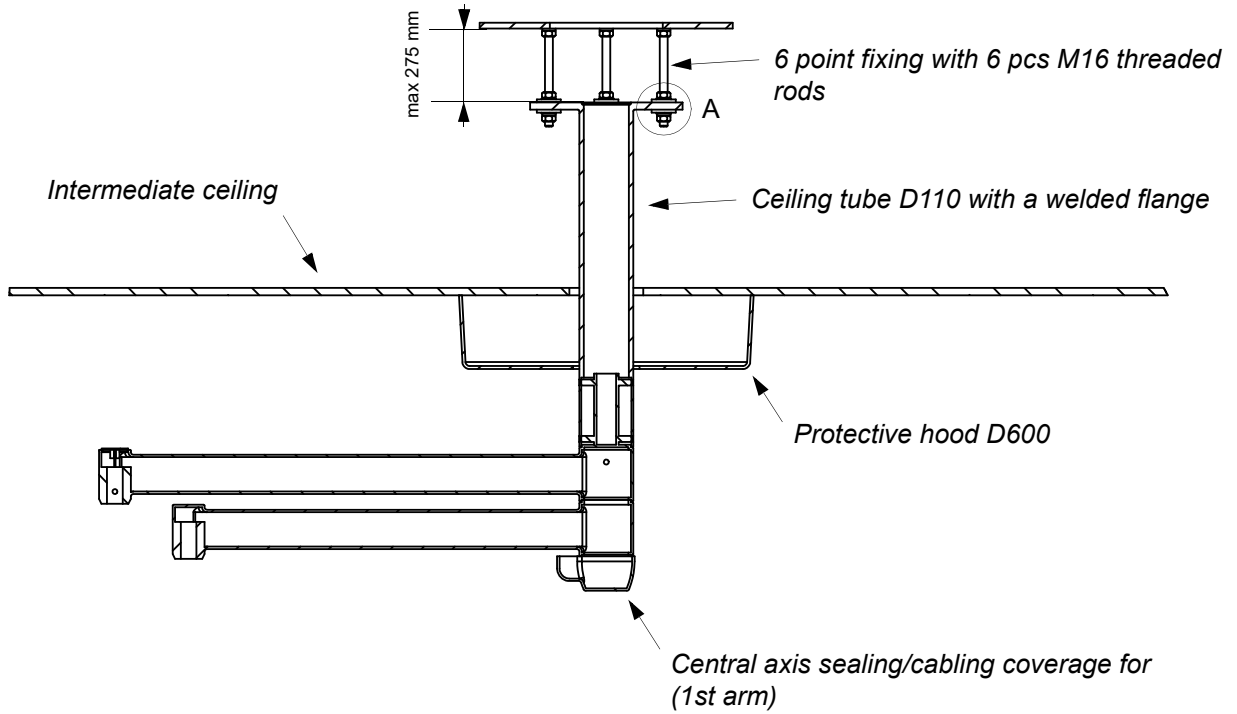

Picture 8. Central axis with two extension arms (DUO)

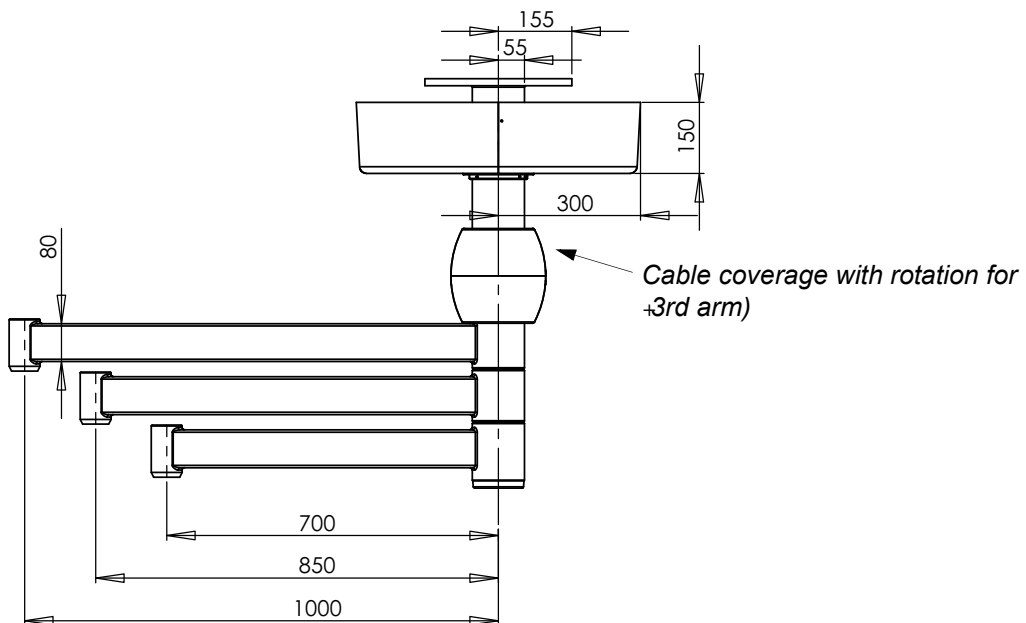

Picture 9. Basic dimensions of central axis for the ceiling tube D110 (DUO and TRIO)

### 3.6.1 Ceiling tube D110 with welded flange - Q-Flow DUO and TRIO

- Fix the tube from 6 points to the interface plate with a fixing set.
- Attach the ceiling tube D110 (1) with a welded flange to the ceiling with the interface plate as described in section [3.3.1 Raw ceiling installation on page 14](#).
  - Fit the M16 threaded rods (3) with the plastic insulation washers (6) with 34 mm outside diam., spring washers (7) and M16 hexagonal nuts (4) in place.
  - Tighten the ceiling tube between the M16 nuts to a moment of 100 Nm.
  - Position the tube vertically by using a spirit level (2) and if needed, make refinements by adjusting the fixing nuts (4).

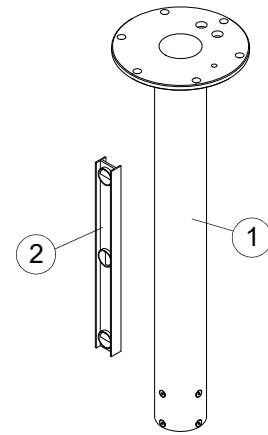

#### Interface plate fixing set:

- |                            |        |
|----------------------------|--------|
| - ( 3 ) M16 threaded rods  | 6 pcs  |
| - ( 4 ) M16 nuts           | 13 pcs |
| - ( 5 ) M16 washers        | 7 pcs  |
| - ( 6 ) Insulation washer  | 13 pcs |
| - ( 7 ) M16 spring washers | 13 pcs |

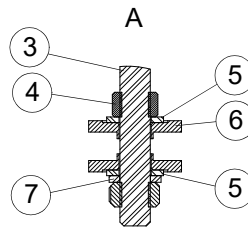

### 3.6.2 Installing extension arms to the ceiling tube D110 - Q-Flow DUO and TRIO

- Remove screws (1) from the ceiling tube (2).
  - Lift the extension arm(s) (3) close to the tube and feed the cables through. Check the connector shaft (4) of the central axis is going up in straight.
  - Lift the extension arms (3) inside the ceiling tube (2).
  - Fix with screws M8X12 A2 DIN7991 (1), 8 pcs.
  - Install the central axis sealing/cablings coverage (5) supplied to the bottom of the central axis, when the monitor cabling is fed manually through the 1st arm.
- The coverage can be also a conical plug type if the luminaires are installed into both arms

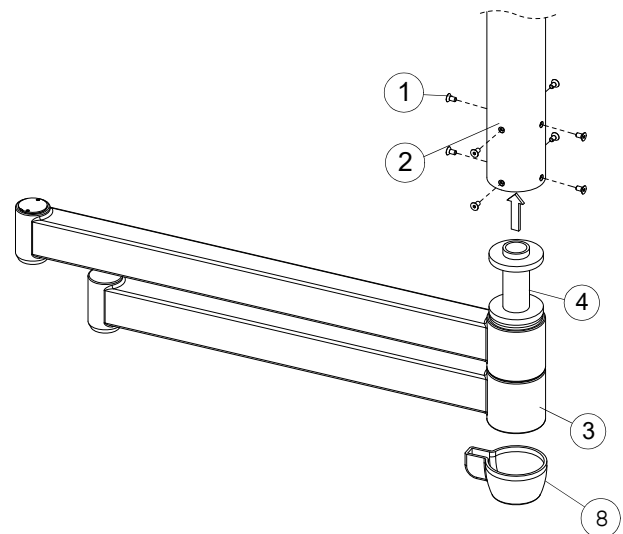

Below is represented a recommendation on how fixed central axis stops should be positioned in relation to the operation table and patient in an operating room. Always check the system supplier's manual for more information.

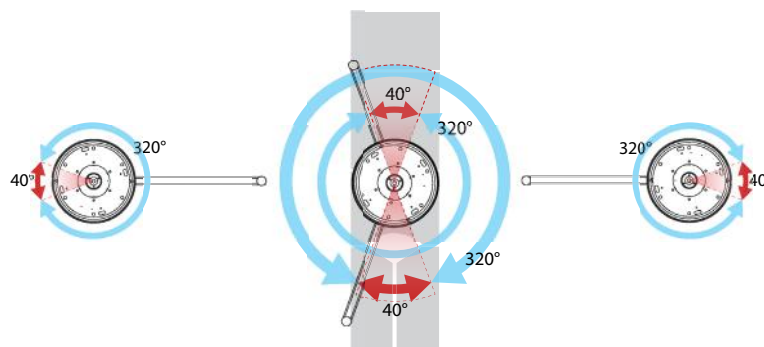

### 3.6.3 Installing the protective hood D600

1. Put halves of the protective hood (1a-b) against each other and fix with screws (2) 6 pcs.
2. After installing the protective hood, secure it with the fixing collar (3) by using locking screws (4) and (5).

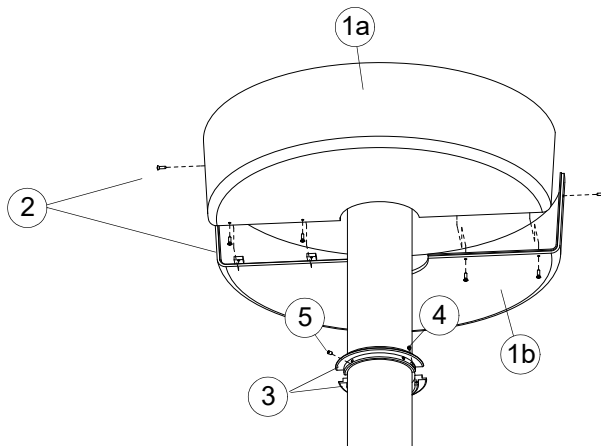

### 3.7 Installing the balance arms - Q-Flow SOLO, DUO, and TRIO

**!** **NOTE!** The supplied balance arm is factory set to the locked position at the factory; do not pull or push the arm by force.

Unpack the balance arm and remove all protective sleeves and plastic plugs from the shaft contacts and sliding connectors. Adjustments and the releasing of the arm can be performed after the balance arm has been installed to the extension arm of the central axis.

1. Install the balance arm (1) is into the extension arm (3) with a washer (4) and circlip (5).
2. Open the screws (7) 2 pcs by securing the extension arm tube covering plug (6).

**!** **NOTE!** Special circlip pliers needed! Pliers must be set to a 8 mm strut limitation to prevent deforming or over stretching the lock ring (circlip).

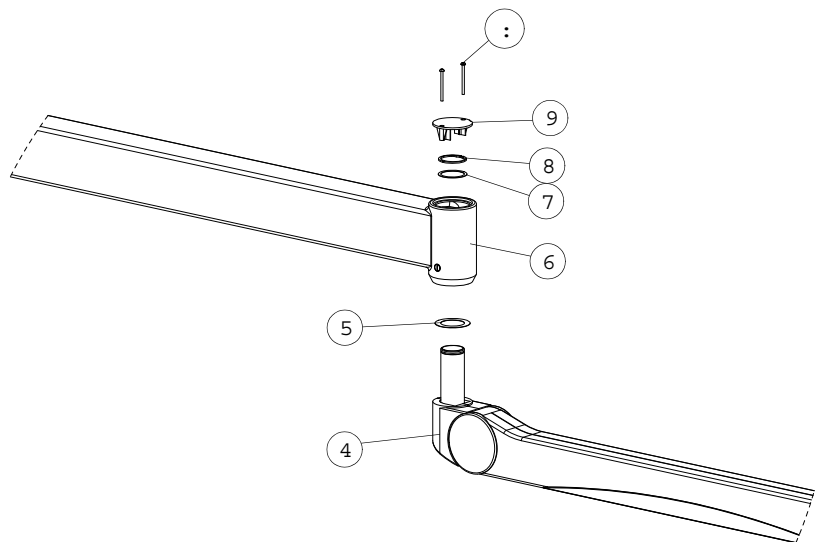

Picture 10. Installing the balance arms - Q-Flow SOLO, DUO and TRIO

**!** **NOTE!** Never install a damaged product or fixing part.

**!** **NOTE!** Ensure that the male plug inside the balance arm is not damaged during the installation.

**!** **NOTE!** The connector can not handle strong force or impacts.

**!** **NOTE!** Do not lose the circlip or the washer; there is only one of each supplied!

**!** **WARNING!** The circlip (5) must audibly snap in place into the groove of the balance arm (1) shaft. The lock ring is correctly mounted if it can be rotated in the groove.

### 3.7.1 Dismantling the circlip (Lock ring) from the balance arm

The circlip and the washer disc have to be dismantled from the spring arm shaft (parts that are fixed to the balance arm). Dismantling the securing ring by using circlip pliers with a strut limitation mechanism.

1. Dismantle the circlip (Lock ring one pcs part 5, refer to Picture 10. Installing the balance arms - Q-Flow SOLO, DUO and TRIO on page 28) and washer disc Ø 39 mm (one pcs part 4) on the balance arm with 3-pole connectors.
2. Also remove the securing sleeve from the balance arm shaft in the upward direction.
4. Check that the washer disc Ø 48 mm (Part number 2, refer to Picture 10. Installing the balance arms - Q-Flow SOLO, DUO and TRIO on page 28) is mounted to the bottom of the balance arm shaft base.



**NOTE!** The washer disc Ø 48 mm is not installed if the balance arm with limit stop is used. The Q-Flow Mobile balance arm uses a specialised limiter and separate Ø 48 mm washer disc is not needed.



**WARNING!** Mark the lock ring (circlip) as a single-use item and keep it in a safe place for later mounting.



### 3.7.2 Balance arm adjustments (5202005)

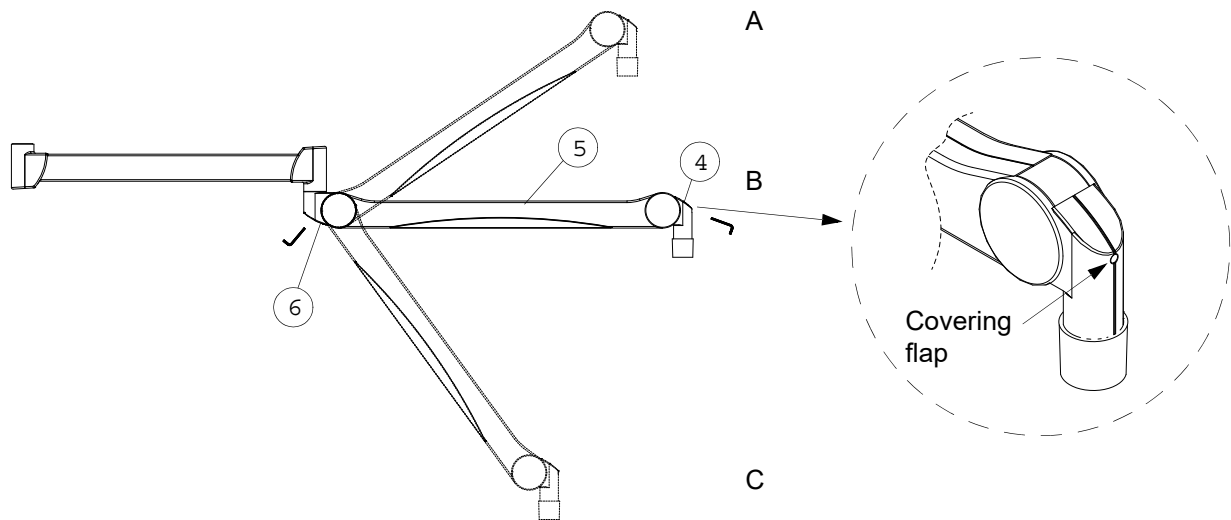

Picture 11. Balance arm adjustments

After the Q-Flow luminaire or other appliance has been installed, you can adjust the balance to suit the weight of the end device. Adjust the balance by tightening or loosening the hex screws inside the balance arm's pivot (3). Check the adjustment procedure of the installed balance arm, because it may differ between models. Always tighten one quarter turn at a time, and keep the balance arm steady in horizontal position when adjusting.

- Check the stiffness of the adjustment moving the arm downwards. Do not overtight!
- To increase the lift (if the luminaire moves downwards from its position too easily or by itself), turn the adjustment screw (3) counter-clockwise.
- To decrease the lift (if the luminaire moves upwards from its position too easily), turn the adjustment screw (3) clockwise.

#### 3.7.2.1 Movement range of balance arm (5202005)

- The angle constraint can be adjusted between 0-45° (B-A). The right height adjustment depends on used extension arm (2) settings, otherwise movement around balance arm vertical axis might be limited.
- Insert an Allen key through the covering flap and slot it into the head of the screw (1).
- In order to increase the movement range upwards: turn the screw (1) counter-clockwise. The maximum angle in position (A) is a 45°.
- Correspondingly, the reduction of the angle is performed by turning the screw (1) clockwise. In the transport state, the balance arm (2) can only bend downwards 50° (C), which is the limit of its movement range. Upwards movement is restricted to the horizontal position.

Feed the wires through the arm assemblies in such a way that they do not get damaged or pinched from harmful effect of mechanical strain. Wires between the arms are connected with 3-pole sliding contact plugs and sockets (3-pole connectors).

**!** **NOTE!** The balance arm model with a specific type selected along the used end device specifications.

### 3.7.3 Low ceiling height versions of balance arms (LCH)

Low ceiling height balance arms (LCH) are for special conditions, in which the room height is limited. Single yoke version of the Q-Flow luminaire combined with this balance arm type allows to select a ceiling tube which can be installed closer to the concrete ceiling or dropped/intermediate ceiling surface.

**!** **NOTE!** The LCH-type balance arm is also used with the Q-Flow Mobile version.

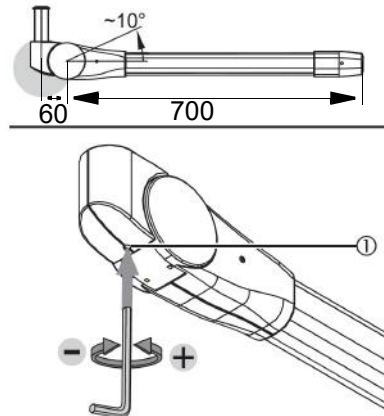

Picture 12. LCH low ceiling height version

Balance arm spring tension (1) is adjusted from the base joint with the 5 mm Allen key. Turning the Allen key counterclockwise increases the tension and turning it clockwise decreases the tension.

**!** **CAUTION!** Before adjusting the spring tension, release the vertical limit screw and set the arm approximately 10 degrees above the horizontal line to get the access to the spring tension screw (1).

**!** **CAUTION!** You must first relieve the balance arm by pulling the arm downwards before the vertical limit can be adjusted.

**!** **WARNING!** The washer disc must not sit in the groove on the shaft, but must sit underneath the groove on the balance arm shaft. Use the lock ring (circlip) dismantled during initial installation as described in chapter [3.7 Installing the balance arms - Q-Flow SOLO, DUO, and TRIO on page 28](#). A new, unused securing ring must always be used for service or maintenance. (Lock rings (circlips) are available from System Manufacturer (Merivaara Corp.)).

**!** **WARNING!** The circlip must audibly snap in place in the groove of the balance arm shaft. The lock ring is correctly mounted if it can be rotated into its groove.

### 3.7.3.1 LCH (5202006) type balance arm installation with the Q-Flow

The brake force of the balance arm is set to hold the end device (Q-Flow mobile with a single yoke) in the adjusted position. The balance arm is supplied in horizontal position. The end device of the LCH type balance arms is secured with the wedge and securing ring, with this system after the luminaire has been set in place.

 **WARNING!** Danger of injuries! When the balance arm is pressed downwards, it may rise up suddenly because of the spring tension and cause injuries.

 **NOTE!** It is important to first relieve the balance arm by pulling the arm downwards before the vertical limit can be adjusted.

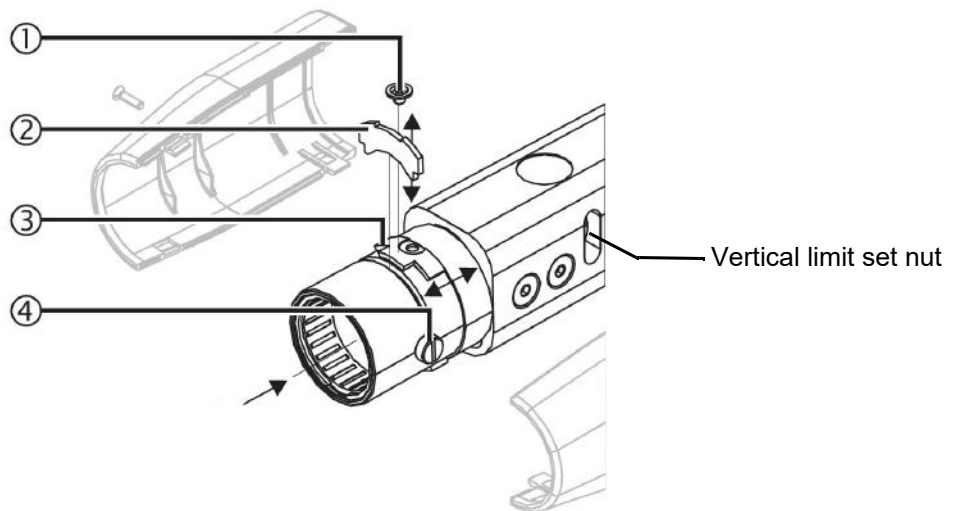

Picture 13. Relieving the balance arm

1. Check that the brake screws (4) 2 pcs are not limiting the luminaire installation. Loose/remove these screws.
2. Remove the securing screw (1) protecting the wedge. Slide the securing ring (3) away to remove the wedge (2).
3. Align the luminaire yoke shaft with the LCH balance arm and insert the sliding connector carefully in place. Secure the luminaire with the wedge from the top and securing ring (3), and tighten the screw (1).
3. Adjust the brake screws (4) until the end device remains in its rotated position.
4. Perform a functional test before installing the protective covers with screws Phillips head M3x12 mm (2 pcs).
5. Vertical limit set nut adjustment is done from the side of the balance arm frame tube. One adjustment pin (4x110 mm) is supplied for this adjustment.
6. Rotating the set nut upwards increases the vertical limit of the adjustment top range, and rotating the set nut downwards decreases the limit. The LCH balance arm adjustment range is - 50° to +30°.

 **NOTE!** Please consult accompanying documents supplied with the balance arms.

 **WARNING!** Electric shock! Power off the on-site power supply and protect it from being switched on again.

### 3.8 Adjustment of the extension arm brake force

The brake screws (1) are slotted screws. Adjust the brake screws (1) in such a way that the end device (e.g. luminaire) stays wherever it is positioned. Note that this is a special feature which is only available in the Q-Flow Medium duty and TRIO systems.

- Use a suitable slot-head screwdriver to screw the two brake screws (1) clockwise on both the front and rear of the extension arm to increase the brake force.

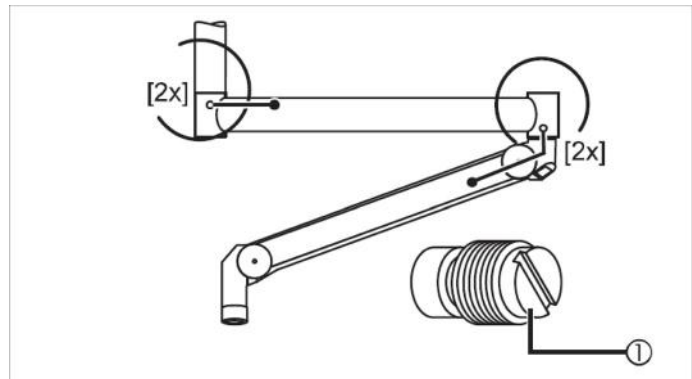

Picture 14. Adjusting the extension arm brake force

**NOTE!** Do not strain the Q-Flow ceiling arms by loading the arms in such a way that the force is directed against its adjustment range limits. Be aware of the existing limits of the system presented in this Q-Flow Installation and maintenance manual.

**NOTE!** Adjust the brake force every time after a camera module has been removed or installed.

### 3.9 Installation of the Q-Flow luminaires

**NOTE!** Installation requires two persons. The balance arm is preadjusted in horizontal position at the factory.

1. Open the screw (1)
2. Pull up the metallic collar (2).
3. Pull out the locking wedge (3) from the balance arm shaft groove.

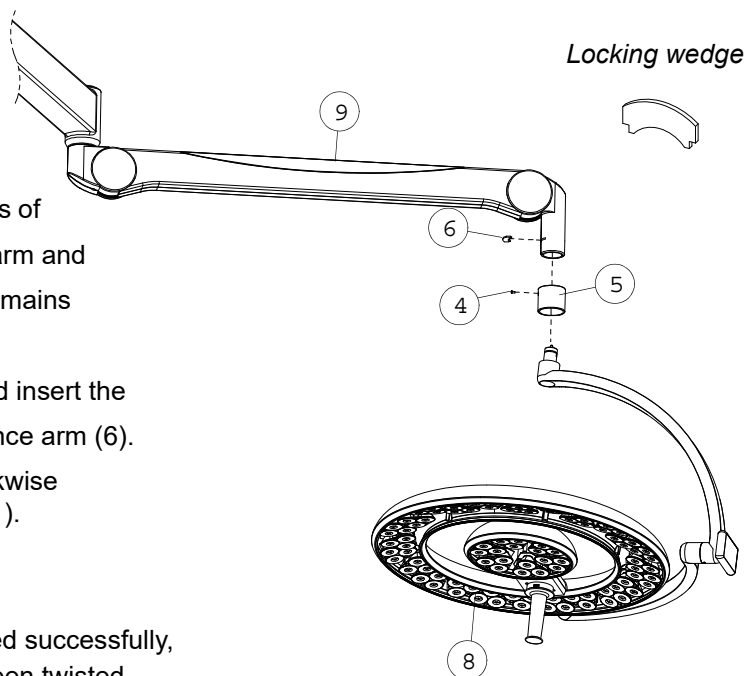

- **SERVICE!** Grease the sliding surfaces of the balance arm shaft and extension arm and ensure that factory greased contact remains intact.
4. Lift the luminaire (5) straight into place and insert the locking wedge into the groove of the balance arm (6).
  5. Lower the collar (2) and turn counter-clockwise approximately 20°, then fix it with screw (1).

**NOTE!** If the installation cannot be performed successfully, check whether the connector pieces have been twisted.

**NOTE!** All Q-Flow luminaire models are installed using a pair of 3-pole connectors.

## 3.10 Installation of the Q-Flow mobile

### 3.10.1 Contents of the Q-Flow mobile luminaire sub assembly

- luminaire base with the locking castors
- protective cover, 1 pcs
- vertical arm tubes, 2 pcs
- balance arm (in own package), 1 pcs
- luminaire (Q-Flow 4 or 6) in own package, 1 pcs
- fixing part set, 1 pcs.

**NOTE!** Lift the upper packaging first away and remove the lower card board packaging sides, then check that all parts from the list in the next Chapter [3.10.2 Fixing parts and required tools for the assembly on page 34](#) are supplied. After these steps, lift the mobile base of from the pallet.

**NOTE!** The mobile base weights 57 kg, be very careful when lifting the base!



**NOTE!** The installation of the Q-Flow mobile requires two persons.



### 3.10.2 Fixing parts and required tools for the assembly

1. balance arm front cover fixing screws, 2 pcs (not mounted), M3x12 mm, countersunk Phillips
2. brake screws 2 pcs, medium flat head
3. wedge for locking the luminaire
4. screw for the wedge securing ring, M4x4 mm hex, 1 pcs
5. vertical tube fixing screws, 2 pcs
6. 3-pole connector levelling collars, 2 pcs
7. 3-pole connector base fixing screws, M5X20, 3 pcs
8. shim ring under the lock ring, 1 pcs
9. lock ring (circlip), 1 pcs

Set the luminaire to a clean, dust free surface and handle it with great care to prevent any damages.

Always wear protective gloves. Antistatic wearing strongly recommended!

**WARNING!** Observe precautions for handling electrostatic discharge sensitive devices!



Picture 15. Fixing parts for the assembly

#### Required tools:

- cross head Phillips driver, size 0 or 1
- regular flat head screw driver size 4 mm for brake screws
- needle nose pliers, tip width approx. 3 mm
- 4 mm and 5 mm HEX keys
- Lock ring pliers with a strut limitation set to 8 mm

### 3.10.3 Installing the lower and upper vertical tubes

Use two M8X20 A2 DIN 7984 HEX screws to fix the vertical arm tube half to the base.

1. Insert the tube carefully in place, note the 3-pole connector receptacle inside the base tube.
2. Align the tube fixings.
3. Tighten the screws.

**NOTE!** Do not over-tighten the screws. Check also that the lower vertical arm tube end is clean and does not contain any burrs from manufacturing, and that there is no paint sagging on the edge of the tube.

4. Attach the 3-pole connector to the receptacle, which comes through the base cover plate opening. The opening on the mobile base plate is also designed for to get access to the battery fuses.

**NOTE!** Press the cover in place towards the base plate before you attach the upper vertical arm tube.

The fixing bushing with sealing tightens the base cover to the base.



**WARNING!** Ensure that the sealing of the cover is intact and the surface of the tube is clean before inserting the cover.

**WARNING!** Check conditions of the mobile version base cover seal if the cover is moved vertically.

5. Align the upper vertical tube fixings and tighten the screws 2 pcs, part no. 5 in [Picture 15. Fixing parts for the assembly on page 34.](#)

**NOTE!** Do not touch the two retaining screws on the lower vertical arm.



### 3.10.4 Installing the balance arm

1. Remove the hex screws, 2 pcs (part no. (6) refer to [Picture 15. Fixing parts for the assembly on page 34](#) ) before you install the balance arm.
2. Move the 3-point connector away.



3. The vertical tube top end contains a fixing bushing for the balance arm (LCH type). Check that the lock ring (circlip) groove is visible from the top of the shaft.
4. Fix the balance arm axle directly to the bushing and secure it with the shim ring and the lock ring (circlip) (parts no. 8 and 9 in [Picture 15. Fixing parts for the assembly on page 34](#) ).
5. Insert the shim ring and the lock ring in place.



**NOTE!** Use suitable lock ring pliers to secure the installation.

**WARNING!** Risk of balance arm dropping! Make sure the locking ring (circlip) is in place correctly! Never install a lock ring (circlip) if it is deformed!

6. After the lock ring is securely in place, connect the 3-pole connector coming through from the vertical tube inside the shaft receptacle.
7. To set the connector in precise distance, levelling bushings shall be installed between the connector base plate and the vertical tube top surface. Part no. (7), 2 pcs.
8. Tighten the screws (part no. (6), 2 pcs, refer [Picture 15. Fixing parts for the assembly on page 34](#) ).



9. Secure the top connection with a plastic cover supplied. Updated design contains a bracket over the top tube opening for a securing M5X20 screw for the top cover.

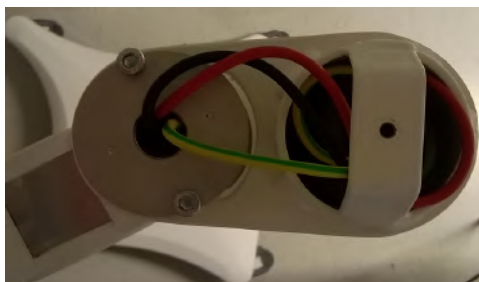

### 3.10.5 Installing the luminaire

Luminaire is fixed to the LCH type balance arm. Perform the balance arm adjustments to decrease the spring force of the balance arm and ease the luminaire installation. Follow the instructions given for the LCH type balance arm in chapter [3.7.3.1 LCH \(5202006\) type balance arm installation with the Q-Flow on page 32](#).

1. Remove the balance arm front end covers.
2. Open the securing ring fixing screw and move the ring towards the base, away from the wedge slot.
3. Remove the wedge, which is located in the groove.
4. Check that the balance arm groove is visible, and press the luminaire shaft inside the balance arm until the both grooves are aligned for the wedge.

**WARNING!** Be very careful with the 3-pole connector.

**WARNING!** Risk of balance arm dropping! Make sure the locking ring (circlip) is in place correctly! Never install a lock ring (circlip) if it is deformed!



- ! 5. Insert the wedge in place and secure it with the screw and the securing ring which covers the wedge. Tighten the screw to secure the installation (part no. 4 in [Picture 15. Fixing parts for the assembly on page 34](#)).

6. Install the braking screws on both sides of the balance arm front head, but do not tighten to the bottom after the luminaire is locked in place with the wedge. The brake screw is presented with an arrow in the picture.

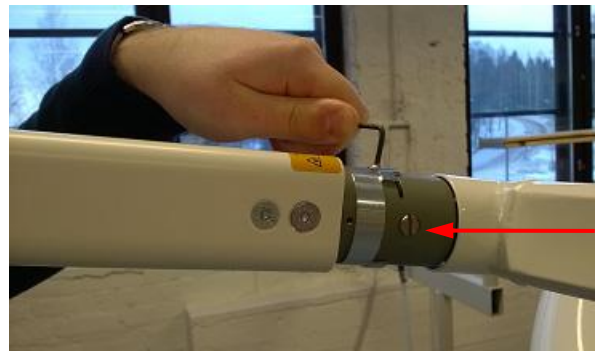

7. After the installation, perform the adjustments for the spring force of the balance arm and angle adjustment. The LCH balance arm adjustments have been described in chapter [3.7.3.1 LCH \(5202006\) type balance arm installation with the Q-Flow on page 32](#).

**NOTE!** Do the adjustments so that the luminaire holds in adjusted position firmly; it must not rotate by itself from the weight of the luminaire.



8. After the luminaire is in place and the adjustments have been done, install the balance arm covers in place with two screws.



9. Tighten the cover screws (Part no. (1)) with Philips head screwdriver.



### 3.10.6 Preparing the Q-Flow Mobile ready for use

1. Connect the mains cable to the base appliance inlet and then to the wall socket.
2. Switch on the luminaire from the mains switch located on the base and then power up the luminaire using an I/O-switch on the luminaire yoke.

**NOTE!** The use of the luminaire has been presented in the user manual, read carefully!  
Adjustments of the balance arm presented in the in this manual.

### 3.10.7 Installation inspection

Check the following items:

1. The luminaire is as ordered.
2. The product surfaces are clean and free from defects in paint work and that there are no scratches, cracks, etc.
3. The luminaire rotates smoothly around its mounting axis and the single yoke, and the horizontal movement of the balance arm stops accordingly to the limit stops on both sides.
4. The balance arm movement stops into the set limits (adjustment range).
5. The luminaire has been installed in a such way it holds in balance and remains in an adjusted position.
6. The mobile base castors lock and release properly.
7. The LASER RADIATION warning label has been attached to the yoke and the laser module, or the current ones have been remained untouched.
8. The luminaire is clean and ready for use.
9. The luminaire main switch operates as intended.
10. The touch screen operates as intended.

### 3.11 Q-Flow luminaire with wireless HD camera module (optional)

 **CAUTION!** Removing and installing the camera must be performed by a qualified technician or an authorized operator or Merivaara Corp.

 **WARNING!** Switch OFF the luminaire on the main switch before removing or installing the camera. Possibility for electric shock or product damage.

Use only equipment that has been accepted for medical use. The Q-Flow luminaire with an optional high definition camera and its video transmission must be configured for the supplied central axis before the system is ordered. Camera settings can be viewed in the user interface of the luminaire in the camera menu. Look at the camera settings menu as well as optional product modules for more detailed information. Check the requirements of your system and availability of this option.

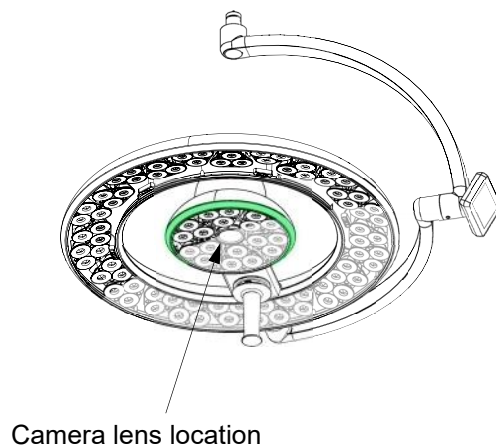

Picture 16. Q-Flow luminaire with the wireless HD camera module

#### 3.11.1 Installing the system containing a monitor

When using Merivaara monitors, the central axis is supplied as cabled through ready for the monitor bracket. In case other manufacture's monitors are used, the video signal cabling is fed through the central axis before the signal can be transmitted to the monitor. The camera system configuration and site preparation for the additional product modules are also needed.

For the manual cabling, follow these steps:

1. Remove the cover caps from the extension arm ends.
2. Pull the cables carefully through from the balance arm to top of the extension arm.
3. Fix the balance arm with supplied locking ring (circlip), and follow installation instructions presented in section [3.7 Installing the balance arms - Q-Flow SOLO, DUO, and TRIO on page 28](#).
4. Lift the balance arm central axis assembly by using a suitable lifting device or e.g. holding the extension arms at installation height.

5. Feed the extension arm cables in such a way that the shaft slides easily into place into the ceiling tube. Finally attach the central axis with the balance arm attached to the ceiling tube, and feed the cable packages through the ceiling tube. Notice, the rotation stop installation for the system containing the monitor bracket (cable protection).
6. Enclose the end cap covers. You can now install the luminaire and the monitor bracket which is installed in the same way by using a locking wedge.
7. Connect the connectors coming through from the balance arm to corresponding counterparts.

Check the end device connection diagrams for the illustration. Be extra careful not to harm the cables on installation and perform a signal test to ensure the installation. Notice, the extension arm special coverage installation on the lowest and uppermost arms! Please consult accompanying documents supplied with the balance arms and monitor bracket.

### 3.11.2 Installing the RF unit

Before installation, print the drill guide (a separate document attached to this manual). Print it in A4 size, if you do not have it on paper. Ensure that the scale of the printed drill guide is correct by measuring the sides of the square in the drawing.

The optimal installation location of the signal receiver box minimizes disturbances in the camera signal. Install the signal receiver box always onto the roof, if possible. In case it is not possible, install it onto the wall as close as possible beneath the roof. Ensure that the line of sight between the signal receiver box and the camera is as clear as possible.

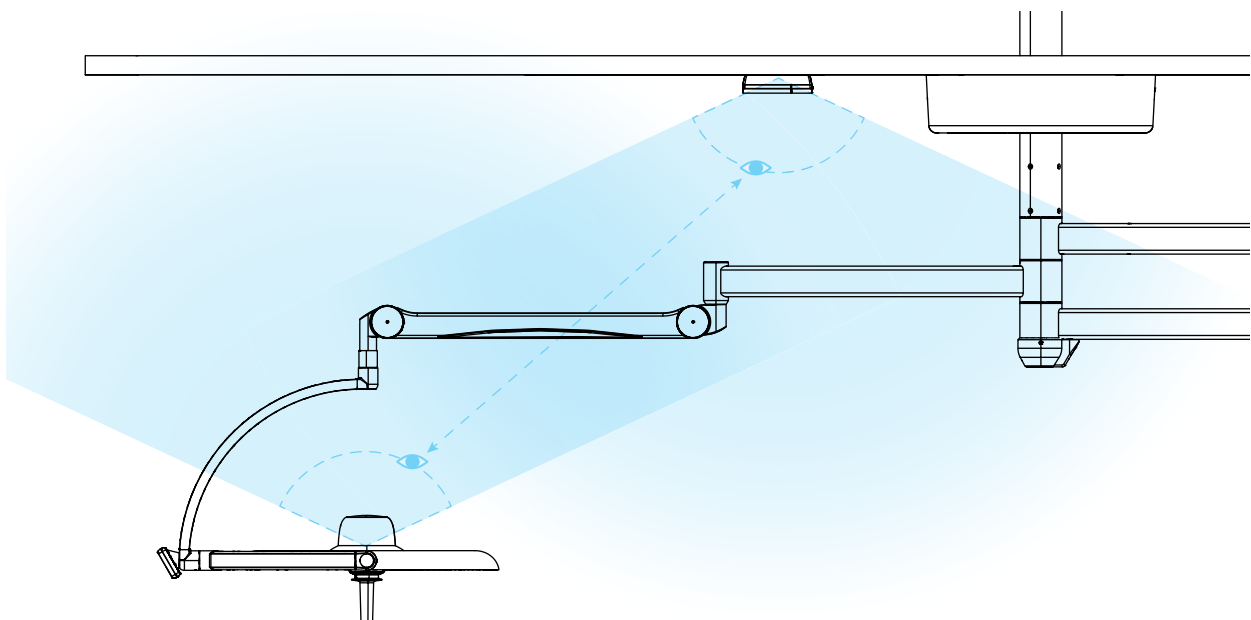

When the RF unit is installed beside the ceiling tube, Merivaara recommends the following (see the image below):

- the operating table is located under the arm assembly
- the luminaires are located at the end of seat or leg section
- the RF unit is installed beside the operating table which ensures that the ceiling tube disturbs the line of sight as little as possible.

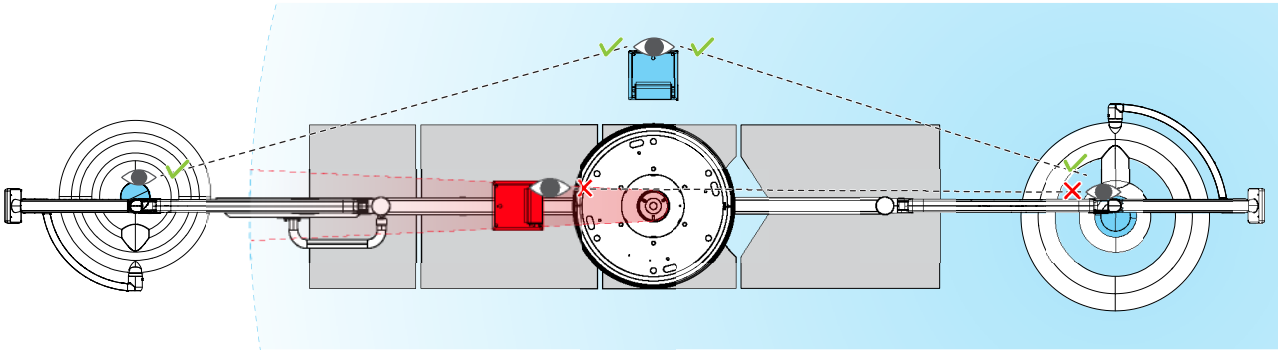

The signal receiver box is recommended to be attached at the distance of 300 mm from the protective hood (the minimum required distance is 100 mm).

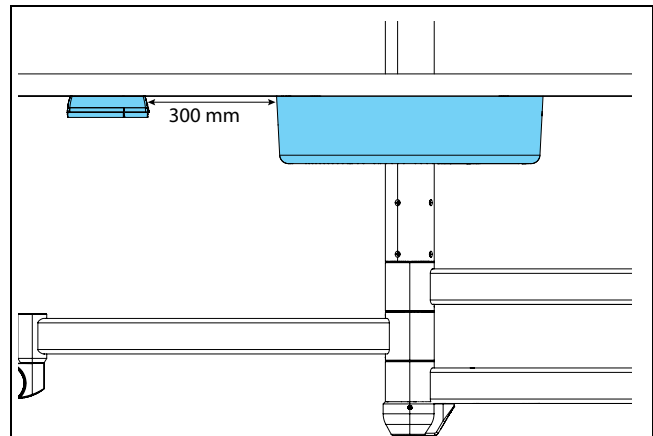

Picture 17. Optimal installation location of the signal receiver box

1. Open the cover (1) of the signal receiver box.

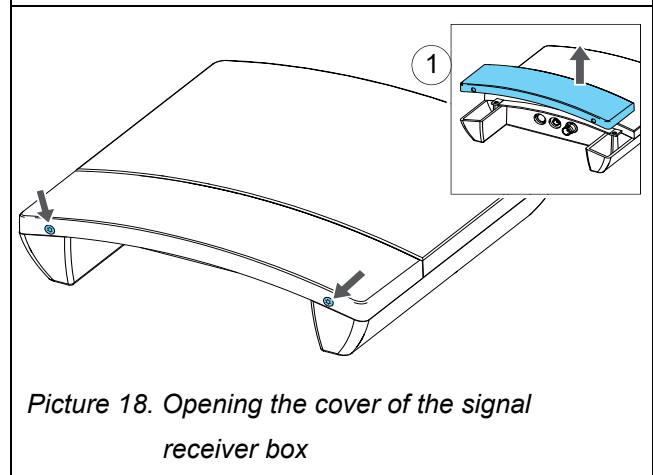

Picture 18. Opening the cover of the signal receiver box

2. First attach the screw (2) which attaches the box onto the roof box. Leave it a bit loose so that you move the signal receiver box to the correct position.

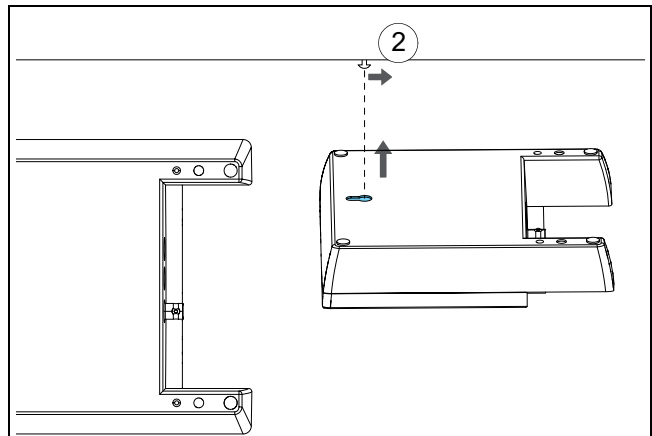

Picture 19. Attaching the signal receiver box

3. Attach the box onto the roof by attaching two other screws (3).
4. Close the cover of the signal receiver box.

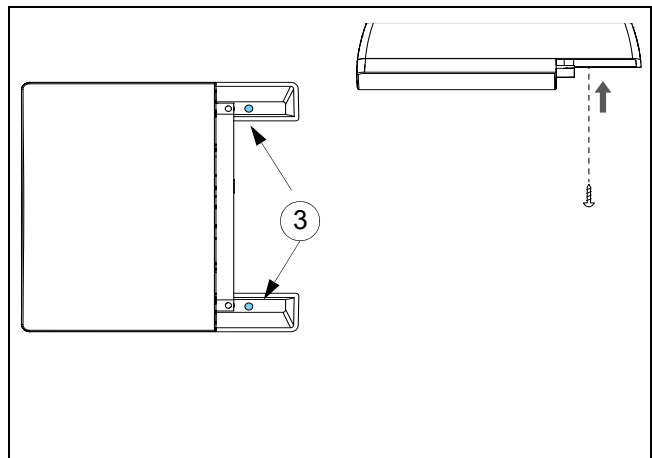

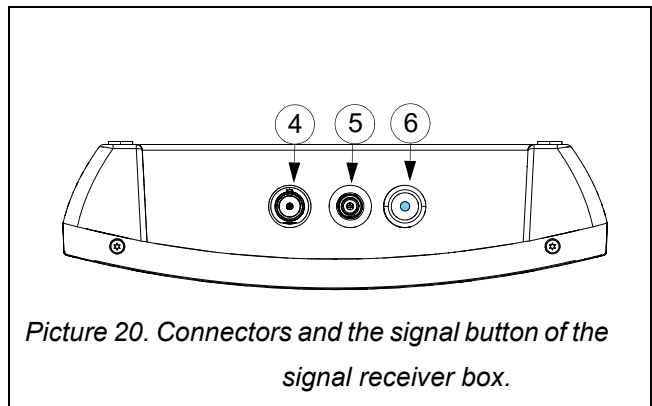

5. Plug in the power connector (5) (included in the signal receiver box package) and the BNC connector (4). Video signal output button (6) indicates the status of the signal.
6. Pair the signal receiver box with the camera (refer to chapter [3.13.5 Pairing the camera with the network on page 58](#)).



Picture 20. Connectors and the signal button of the signal receiver box.

### 3.11.3 Removing the camera

 **CAUTION!** Always handle the camera with great care. Do not touch the lens, transceiver or the connector. If the camera hits obstacles, it may get broken.

 **WARNING!** Removing the camera module considerably reduces the weight of the luminaire. This may cause the luminaire to spring up. To prevent this, ensure to hold on to the luminaire while removing the camera module. You can also reduce the movement range of the balance arm before starting the procedure (refer to Chapter [3.7.2 Balance arm adjustments \(5202005\) on page 30.](#)).

1. Switch Off the power on luminaire from the main switch.

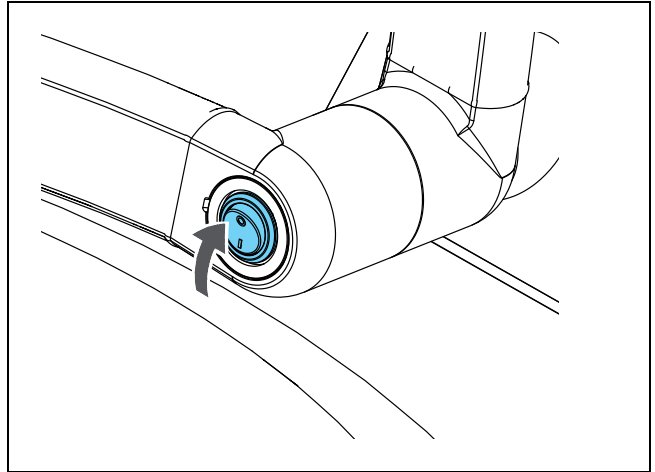

2. Remove the camera cover: open the cover by using a slotted screwdriver. Carefully lift the cover.

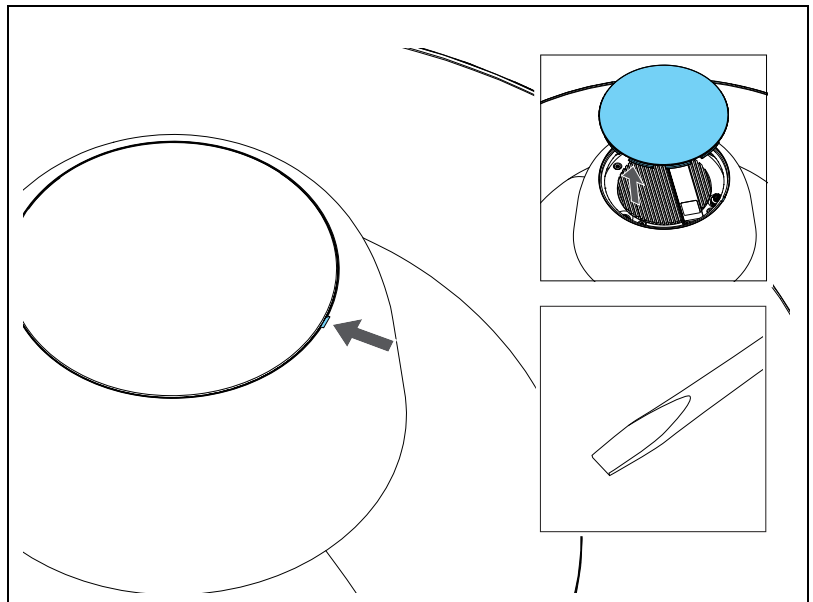

3. Turn the camera module so that the mark on the lock ring and the camera cover assembly line up.

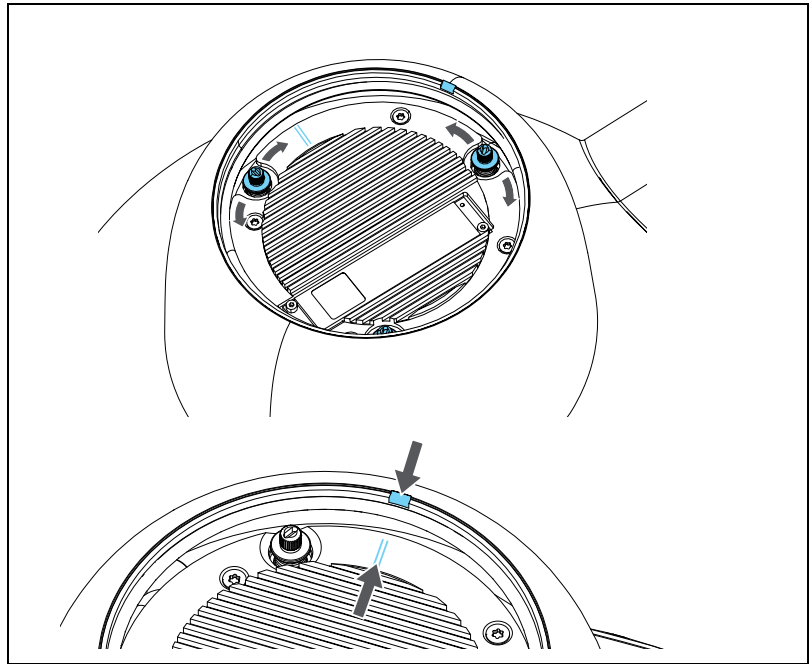

4. Remove the camera assembly:  
Firmly press down the screw (3 pcs), and turn it counterclockwise with a slotted screwdriver to loosen it.  
5. Pull the camera carefully out.

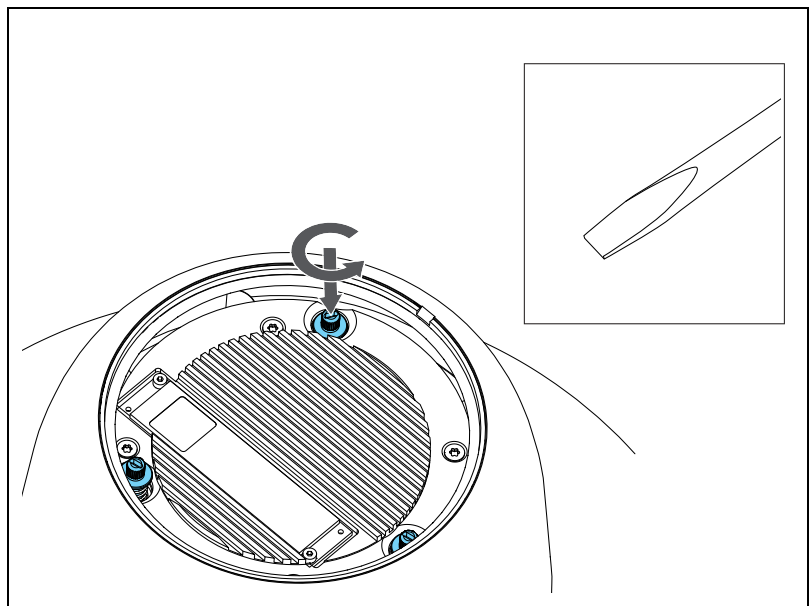

6. Put the cover firmly back onto the luminaire.

**NOTE!** Check that the cover is firmly in place.

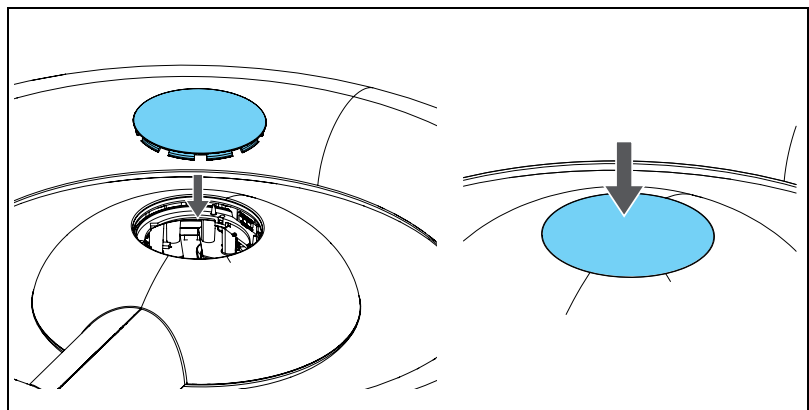

7. Switch ON the power.
8. Check that the luminaire functions.

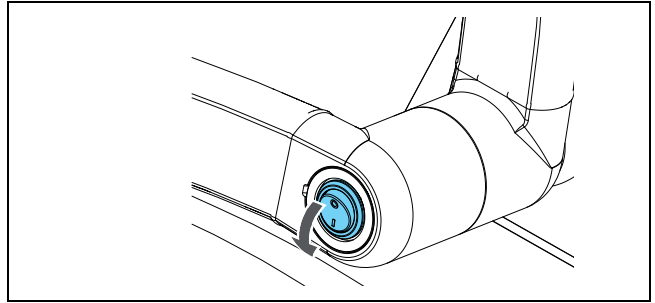

### 3.11.4 Installing the camera

1. Switch Off the power on the luminaire from the main switch.

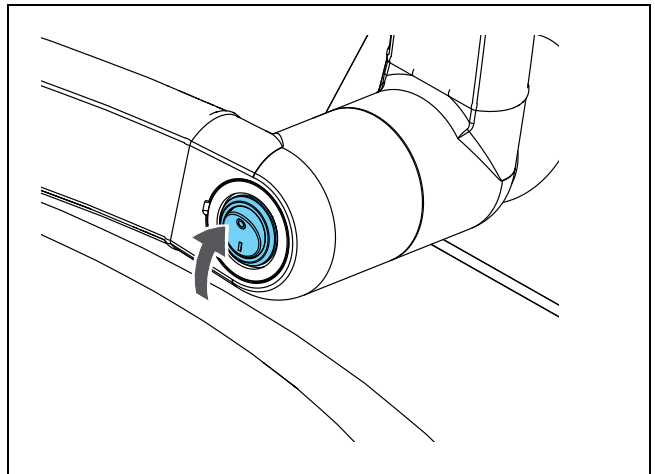

2. Remove the camera cover: open the cover by using a slotted screwdriver. Carefully lift the cover.

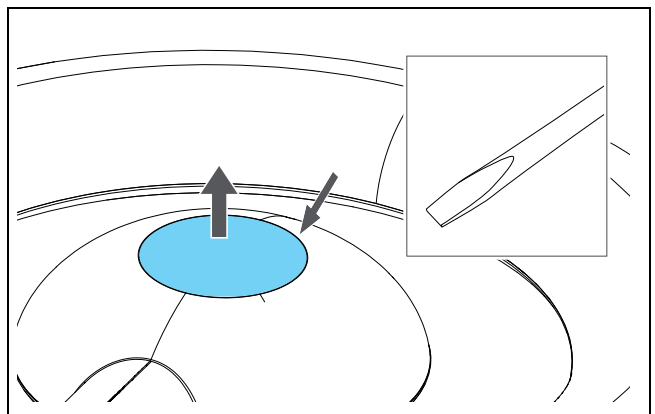



3. Turn the camera module to a correct position. Ensure that the mark on the lock ring and the camera cover assembly line up.

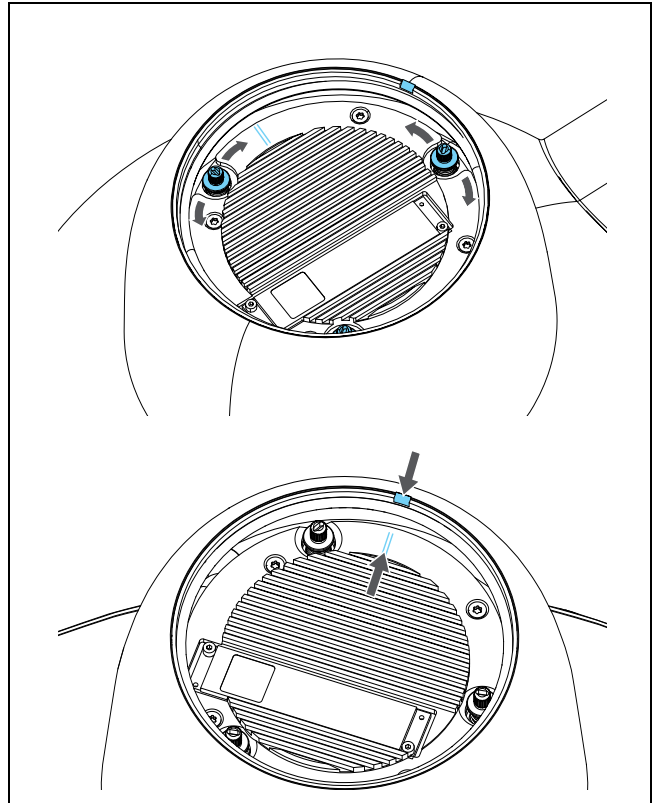

4. Hold the camera module firmly and place it in a straight position into the camera module assembly. The PCB connectors in the module must be in line with the connectors in the camera module fixture assembly. Turn the camera module to a correct position. Ensure also that the mark on the lock ring and the camera module fixture assembly line up.

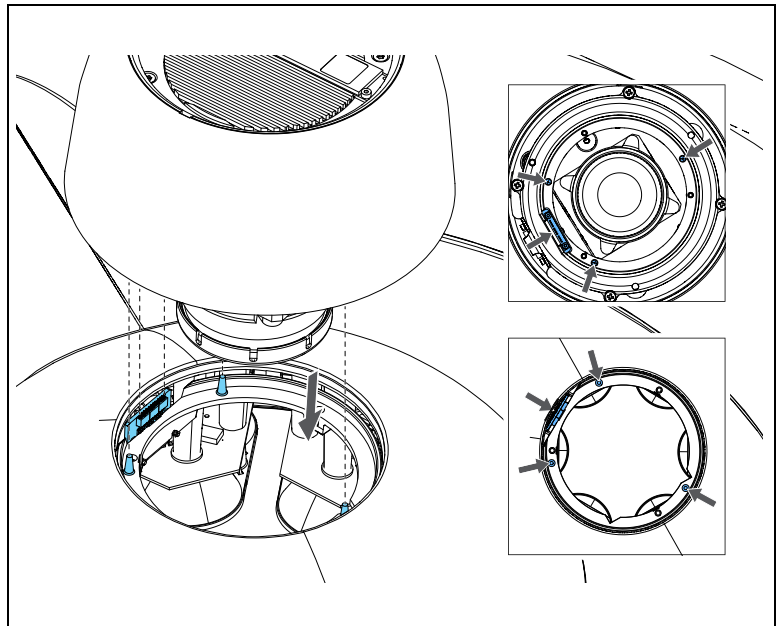

5. Insert the camera module into its place: use a slotted screwdriver to firmly press down the screw (3 pieces), and turn it clockwise to tighten it. Before tightening the screws, ensure that the screws are correctly in their slots; if not, you cannot press and screw them correctly.
6. Close the camera cover.

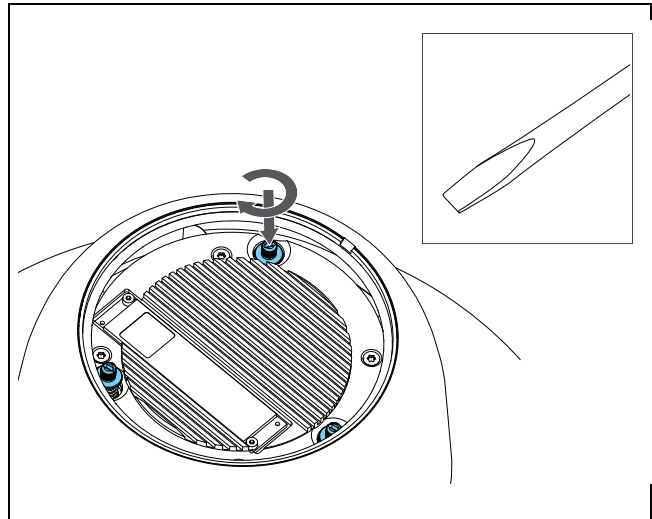

7. Switch ON the power.
8. Check that the image is transmitted. Pair the RF unit and the camera module again, if necessary (refer to chapter [3.13.5 Pairing the camera with the network on page 58](#)).

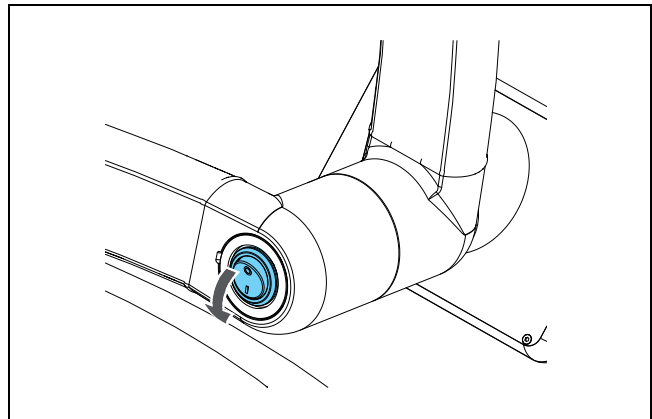









### 3.11.5 Installing the wall mounted control panel (optional)

The Q-Flow system can be complemented with the wall mounted control panel covered with a casing, which can be installed to the wall with a bracket. Cabling is fed to the casing connection port.



### 3.12 Definition of user interface icons

	Switch On
	Switch Off
	Color temperature
	Brightness
	Light area
	+ Increase value (%)
	— Decrease value (%)
	rotate right/left
	Pause- Still image snap shot



Icon of luminaire



Icon of camera



Icon of settings



Standby/Power on icon of the luminaire



Yellow **NOTE!** icon for the action needed by user



Red **WARNING!** icon of critical error (may occur only on OpenOR or Merimote)



Synchronization



Selection tickbox



Back to previous menu



Add device



Remove device

### 3.13 User interface of the Q-Flow luminaire

#### 3.13.1 Starting the use

The touch screen panel of the user interface enables easy control of the luminaire functions. The touch screen switches on when the main switch is turned on from the yoke.

Touch the screen to activate the user interface.



Picture 21. Idle screen of the user interface

The User Interface opens in the **Lamp** view:



Picture 22. Main view of the Q-Flow user interface

First, change your UI language in the settings, if necessary (refer to [3.13.4.1 Changing the language of the user interface on page 54.](#))

The icons On/Off keys are highlighted with green and red colours on the main tab view in the User Interface. When a function is selected, the corresponding button in the user interface is highlighted in light blue colour. The Standby key on the upper right corner returns the panel into the idle screen and switches off the light or lights without missing the last settings. The UI laser of the Q-Flow i-series sets off automatically when the luminaire is switched off or on in the standby mode.

The user interface of the Q-Flow luminaire is presented in more detailed in the next chapters. Read carefully and familiarize yourself with the functions and settings of the user interface.

### 3.13.2 Luminaire (lamp) menu

The user interface opens in the main **Lamp** menu. If a lamp has been switched on before starting the user interface, also the User Interface starts in **On** mode.

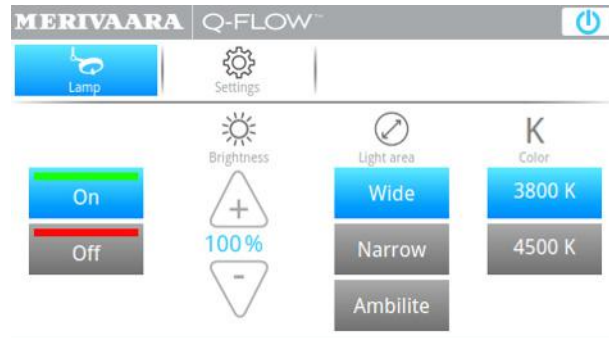

Picture 23. Lamp menu

The Lamp menu contains the following functions and buttons:

**On/Off** – Switches the lamp ON/OFF.

**Brightness** – The sun icon represents the light intensity. Adjust the light intensity (brightness) by pressing the arrow buttons with +/- symbols. When you press the button, the intensity changes by 10% at a time. When you press the button constantly, the intensity changes by 5% at a time.

**Light area** – Indicates the size of the light field. Use the **Narrow** and **Wide** buttons to reduced or increase the value. The **Ambilite** function is used when a dim lighting condition is needed; the light is generated from the edge trim.

**N** – Select the colour temperature (3800 K or 4500 K) by pressing the corresponding button.

If other devices or luminaires have been synchronized to the system, you can control all via one touch screen by selecting **Control all** in the main lamp view (see picture below)

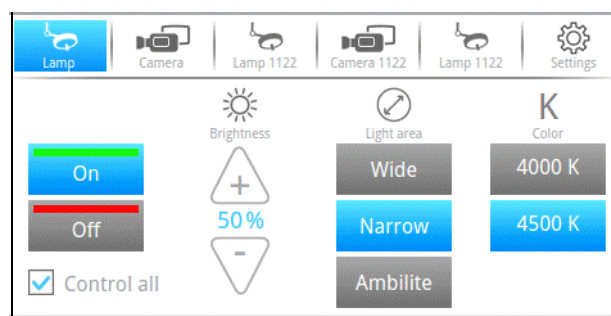

Picture 24. The Lamp view with maximum amount of devices

### 3.13.3 Camera menu



**NOTE!** The system detects the camera automatically, if it has been installed into the luminaire.

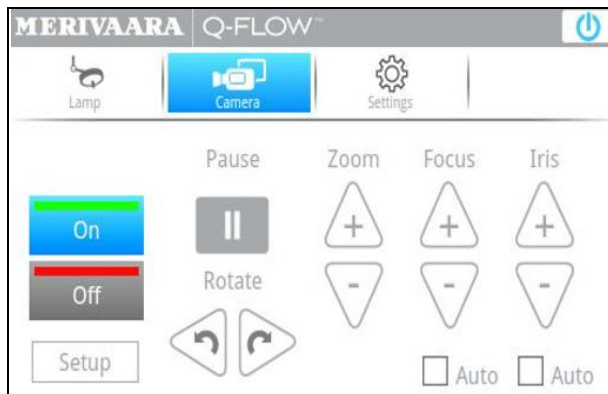

Picture 25. Camera menu

**On/Off** – Camera switched ON or OFF

**Setup** – Opens the **Setup** menu in which you can pair the camera with the internet connection. The Setup menu requires a PIN code.

**Pause** – Still image snap shot



**NOTE!** Recording is only possible via the *Merivaara* OpenOR system.

**Rotate** – Arrow buttons for rotating the camera. The rotation of the camera is 350°.

**Zoom** – Use the +/- buttons to manually zoom in or out the camera.

**Focus** – Use the +/- buttons to manually focus the camera. Select “Auto”, if you want to use automatic focus.

**Iris** – Use the +/- buttons to control the amount of light coming through the lens. Select “Auto”, if you want to use the automatic iris control.



### 3.13.4 Settings menu

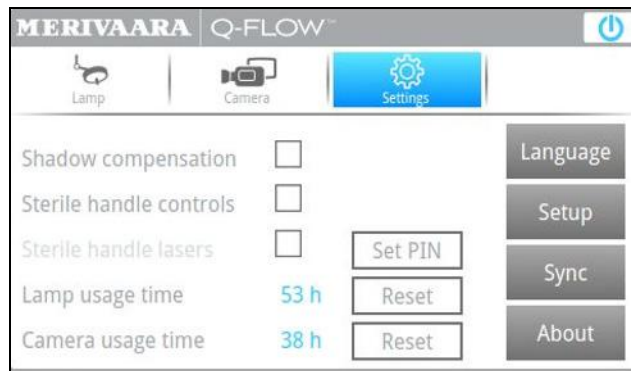

Picture 26. Settings menu

**Shadow compensation** - Minimizes shadows within the work field. Detects automatically an object interposed between a particular LED module and the work surface. The power to that LED module is decreased, whereas the power of other LED modules increases.

**Sterile handle controls** – Enables using the handle for controlling the luminaire.

**Sterile handle lasers** –The function **Sterile handle lasers** is inactivated as default. To enable it, first tick **Sterile handle control**. After that you can also activate the **Sterile handle lasers** function.

**SET PIN** – opens a pop up window for changing the changing the PIN.

**Lamp usage time** and **Camera usage time** - Shows the actual time the lamp/camera has been used.



**NOTE!** **Reset** options are available only for technical personnel.

**Language** – Opens a menu for changing the language

**Setup** – Opens a menu for adding a new lamp

**Synch**–Synchronizes the slave lamp with the master lamp

**About** –Shows the product information

#### 3.13.4.1 Changing the language of the user interface



Picture 27. The Language options in the **Settings** menu

In the **Language** view, press the desired language to select it.

### 3.13.4.2 Setup menu - Connected devices

In the **Setup** menu you can add or remove devices and view all devices connected to the lamp. The list is empty, if no devices have added (see picture below).

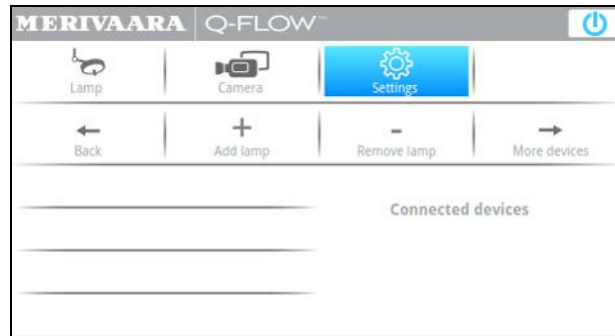

Picture 28. Setup menu with no connected devices

If devices have been connected (see picture below) the first devices in the list are devices which are controlled by this lamp, after that are listed devices and lamps that are controlling this lamp. More devices may be available by selecting "More devices".

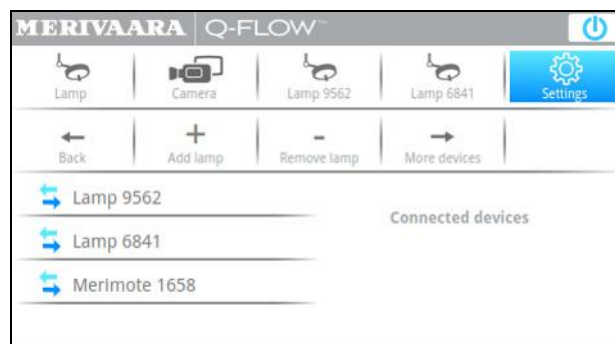

Picture 29. Setup menu with maximum number of connected devices

### 3.13.4.3 Synchronizing/adding a lamp

1. Select **Settings** – **Setup** and press **Add lamp** in the user of the master luminaire.

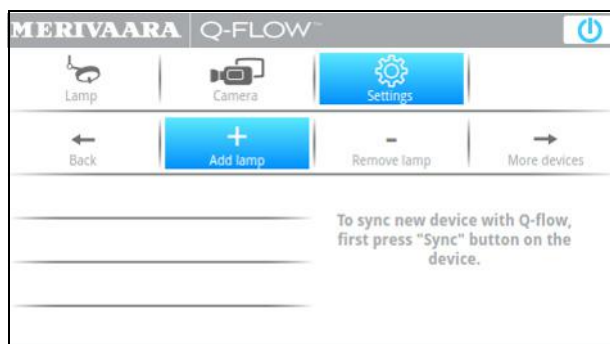

Picture 30. Adding the lamp

2. Press the **Sync** button on the slave lamp which you want synchronize with main luminaire.

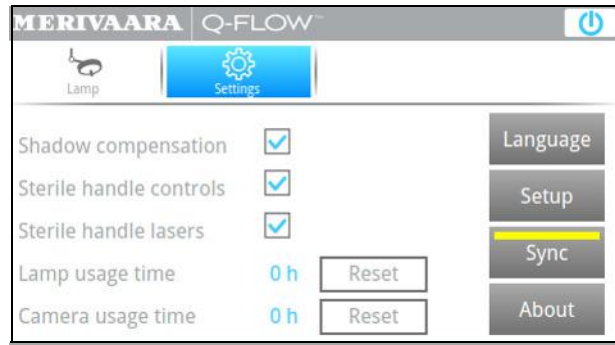

Picture 31. Menu in the slave lamp- Synchronizing ongoing

The yellow light in the **Sync** button indicates that the synchronizing is in process. The light changes to light green, when the synchronizing process has been successfully completed. The red light indicates that the synchronizing process has failed.

After the **Sync** button has been pressed on the slave luminaire, the lamp is shown on the list in **Setup** view of the main luminaire:

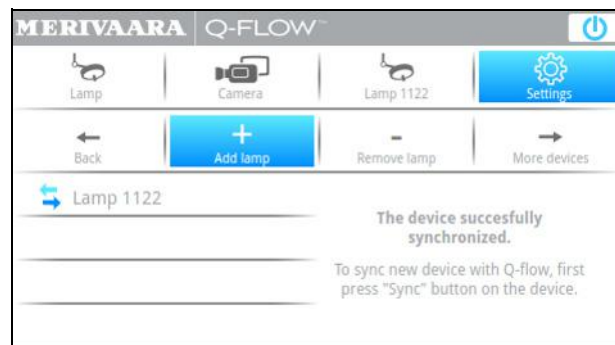

Picture 32. The lamp 1122 has been detected in the main luminaire

3. Click the detected luminaire to complete the synchronization.



Picture 33. Menu in the main lamp- a device is sending a synchronizing request

After the synchronizing is completed, the text “The devices successfully synchronized” is shown on the screen of the main lamp.



Picture 34. The device has been synchronized in the main lamp view

#### 3.13.4.4 Removing a lamp:

1. Select **Settings–Setup** and press **Remove** lamp.

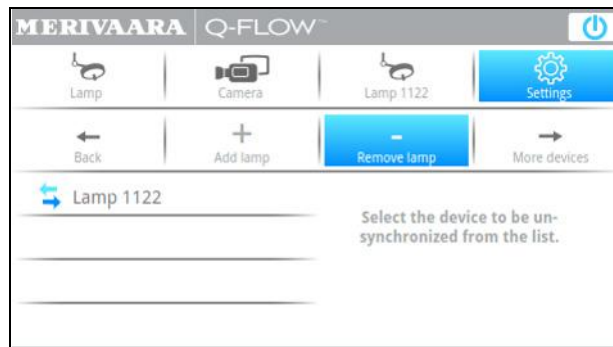

Picture 35. Removing the lamp

2. Select the lamp from the list.



Picture 36. Removing the lamp- pop up menu

3. Click **YES** in the pop-up menu.



**NOTE!** If you remove the lamp, you must re-synchronize it to be able to use it again.

### 3.13.5 Pairing the camera with the network

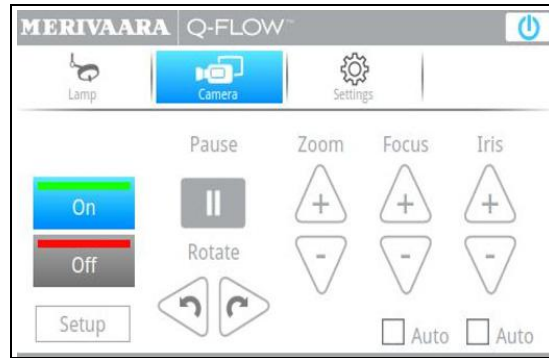

Picture 37. Camera menu for pairing the camera with the network

1. In the **Camera** menu, select **Setup**.
2. Enter the pin code and press **OK**. The **RF unit** menu opens.

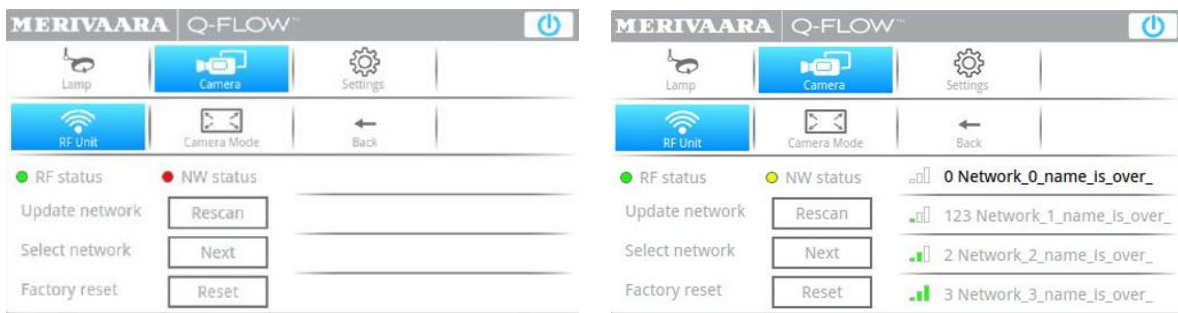

Picture 38. Selecting the network

In the **RF unit** menu, select the network from the list.

**Rescan** –Searches the next available video network

**Next** –Selects the next network from the list.

**Factory reset** –Resets the system and restores the factory settings.

**RF Status**–If green, the connection is available. If yellow disturbances in connection.

**Network status** – RED=no connection, YELLOW=connection received, GREEN=connection received and the image is transmitted.

3. Press the video signal output button of the signal receiver box for three (3) seconds to search for the signal (refer to [Picture 20. Connectors and the signal button of the signal receiver box. on page 42.](#)).

The light of the video signal output button indicates the status of the RF connection:

Status light blinks once every second = idle status.

Status light blinks two times in a second = the RF connection has been created.

Continuous light = the image is transmitted

To reset the signal receiver box, press the video signal output button for ten (10) seconds.

4. Open the **Camera mode** menu to select the resolution to correspond with the display.

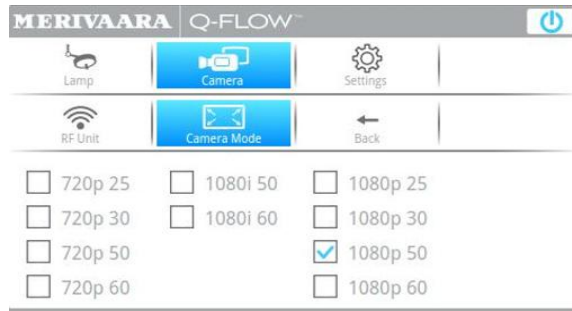

Picture 39. Selecting the Camera Mode

### 3.13.6 Starting the diagnostic test

1. Enter the PIN code to start the diagnostic test.



Picture 40. Pop-up view of diagnostic tool

2. Touch the “Press” buttons which appear on each corner of the display to confirm the functionality of the touch screen.



Picture 41. The diagnostic test of the touchscreen.

3. Confirm the diagnostic tests of the LCD backlight by answering **Yes** or **No** to the questions.

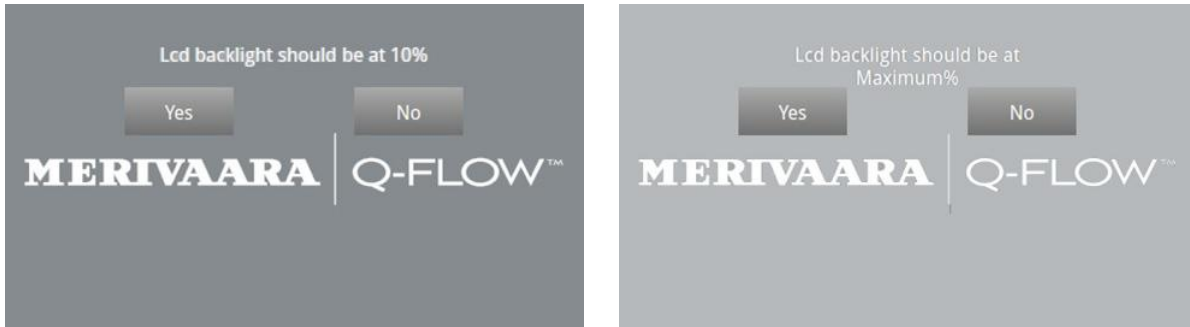

Picture 42. LCD screen backlight diagnostic, steps 1 and 2



Picture 43. Pop-up view, LCD screen backlight diagnostic, step 3

The results of the diagnostic test is given on the screen after the test is performed. The green light indicates a passed result and the red means a FAILED result. After the diagnostic test is completed, the luminaire controls can be used normally.

**!** **NOTE!** If the diagnostic test fails, contact Merivaara's Customer Care.

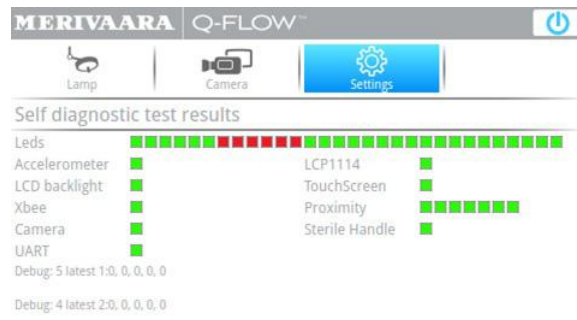

Picture 44. Diagnostic test results

### 3.13.7 Resetting the lamp and camera counter

**!** **NOTE!** The counter for the camera and lamp must only be reset by maintenance of Merivaara's Customer Care.

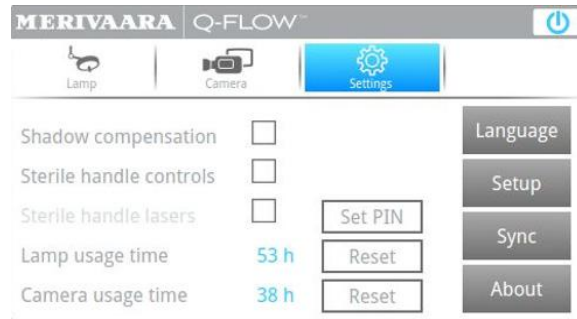

Picture 45. Resetting the camera and lamp counter



## 4. CLEANING

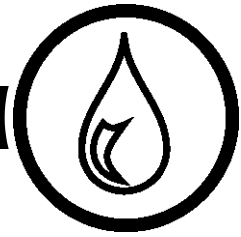

**CAUTION!** Always switch off the luminaire before starting cleaning procedures.



**NOTE!** The responsible organization must also follow the national requirements for hygiene and disinfection.



**CAUTION!** Use of excessive amount of liquids may cause fluid access inside of the device and cause damage to the equipment. Do not expose the product to liquids more than it is necessary in order to achieve adequate cleaning and disinfection results. Follow the given instructions to prevent spillage and ingress of liquids to protect the device.

### 4.1 Covering front glass of the luminaire

Clean the front glass regularly with a damp cloth by wiping with a mildly alkaline detergent (pH 7-8). Anti-static cleaning agents may be used.



**CAUTION!** Do not use harsh cleaning detergents or detergents containing phenol, alcohol or other corrosive agents with covering front glass, as its raw material polycarbonate plastic might be damaged.



**NOTE!** The covering front glass should be kept optically clear.

### 4.2 Luminaire cleaning

- Allow the luminaire head to cool down before cleaning.
- Clean and disinfect with a damp, lint-free cloth and mildly alkaline detergent (pH 7-8).
- Dry the luminaire carefully after cleaning.

### 4.3 Disinfecting

- Allow the luminaire head to cool down before disinfecting procedures.
- Disinfect only when necessary.
- Wipe down the equipment with the surface disinfectant used at the facility in accordance with manufacturer instructions, unless the surface disinfectant contains phenols and alcohol, which are corrosive and cause embrittlement to the plastic parts.

### 4.4 Sterilization

- The focus handle is removable and separately sterilizable.
- Sterilization can be done in a steam autoclave using the instrument cycle.
- The maximum sterilization temperature for the part in a steam autoclave is 132 °C, for three minutes at 2.0 bar. The sterilization time has been calculated by determining when the part being sterilized has reached the sterilization temperature specified above. This does not include the heating and cooling times for the part being sterilized.

## 5. MAINTENANCE AND REPAIR

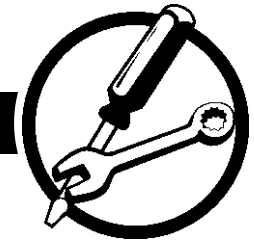

### 5.1 Preventative maintenance

 **WARNING!** Always switch off the system from the power mains before maintenance procedures.

 **WARNING!** Maintenance allowed only by persons specialized and trained to *Merivaara* surgical lights service work.

 **WARNING!** Software update only allowed to persons from Merivaara After Sales or directly at the factory.

#### 5.1.1 Daily maintenance

- During ordinary cleaning, inspect the system and the luminaire whether screws or parts have come loose, and look for evidence of cracks, surface damage and missing parts.
- Check conditions of the mobile version base cover seal if the cover is moved vertically.

#### 5.1.2 Annual maintenance

- The sliding surfaces of the ceiling arms, joints and balance arms should be cleaned and greased at three-year (3) intervals.
- Perform all maintenance measures to the system and the Q-Flow luminaires presented in the separate inspection forms: documents T404338 and T404339.

### 5.2 Troubleshooting

Problem	Cause	Repair
Luminaire moves either up or down on its own.	<ul style="list-style-type: none"> <li>• The settings of the balance arm spring have changed.</li> </ul>	<ul style="list-style-type: none"> <li>• Contact service personnel to check the adjustments.</li> </ul>
The luminaire moves itself.	<ul style="list-style-type: none"> <li>• The break screws have come loose.</li> </ul>	<ul style="list-style-type: none"> <li>• Contact service personnel to check the adjustments.</li> </ul>
The balance arm rotates itself.	<ul style="list-style-type: none"> <li>• The ceiling tube is not straight.</li> <li>• The break screws are too loose.</li> </ul>	<ul style="list-style-type: none"> <li>• Contact service personnel to check the adjustments. Straightening of the ceiling tube or tightening of the break screws needed.</li> </ul>
The balance arm does not move easily.	<ul style="list-style-type: none"> <li>• The ceiling tube is not straight.</li> <li>• The break screws are too tight.</li> <li>• The sliding surfaces have not been greased or the grease has worn away.</li> </ul>	<ul style="list-style-type: none"> <li>• Contact service personnel to check and make the adjustments.</li> </ul>

Table 1. Part 1/2

<b>Problem</b>	<b>Cause</b>	<b>Repair</b>
The lights flickers off when the luminaire is moved.	<ul style="list-style-type: none"> <li>The electrical couplings of the connectors are either not properly attached or are worn.</li> </ul>	<ul style="list-style-type: none"> <li>Contact service personnel.</li> </ul>
The luminaire does not respond to the commands of the touch screen panel.	<ul style="list-style-type: none"> <li>Malfunction of the software.</li> <li>Touch screen panel has been defected.</li> </ul>	<ul style="list-style-type: none"> <li>Start-up the system from the luminaire main switch.</li> <li>Contact service personnel.</li> </ul>
The luminaire does not light up.	<ul style="list-style-type: none"> <li>The fuse of the power unit has burned out.</li> <li>Wiring is poorly attached to main supply.</li> <li>The cord is damaged or broken.</li> <li>The Power unit is damaged.</li> <li>The switching relay of the battery package is damaged.</li> </ul>	<ul style="list-style-type: none"> <li>Contact service personnel.</li> <li>Contact service personnel to inspect the power supply connections.</li> <li>Contact service personnel to make an inspection; inspections related to electrical malfunction only allowed by a licenced electrician.</li> <li>Inspect the PSU unit/fuses.</li> <li>Electrician should inspect/change the relay.</li> </ul>
Weak illumination	<ul style="list-style-type: none"> <li>Settings have changed to defaults.</li> <li>The LED module doesn't illuminate bright enough.</li> <li>Protective front glass is dirty.</li> <li>Ambilite dimming mode is On.</li> </ul>	<ul style="list-style-type: none"> <li>After the luminaire is restarted, controls are set to defaults. Adjust the brightness settings using the touch screen panel controls. If this does not help, contact service personnel to change the LED module</li> <li>Clean or change the glass.</li> <li>Change to the normal light mode.</li> </ul>
The camera of the luminaire does not work.	<ul style="list-style-type: none"> <li>The camera is not configured/ applied to the system correctly.</li> </ul>	<ul style="list-style-type: none"> <li>Contact service personnel.</li> </ul>

Table 2. Part 2/2

<b>Problem</b>	<b>Cause</b>	<b>Repair</b>
The camera picture cuts in and out	<ul style="list-style-type: none"> <li>The signal between the camera and the RF Unit is not good enough</li> </ul>	<ul style="list-style-type: none"> <li>Change the position of the luminaire.</li> </ul>
Video is transferring, but the image is not displayed on the monitor	<ul style="list-style-type: none"> <li>Incorrect video resolution settings</li> </ul>	<ul style="list-style-type: none"> <li>Change the video resolution settings</li> </ul>
Video is displayed in a wrong monitor or not displayed at all	<ul style="list-style-type: none"> <li>The connection between the camera module and the RF receiver unit is not working</li> </ul>	<ul style="list-style-type: none"> <li>Repeat camera module's and RF receiver unit's pairing again</li> </ul>
Video does not show / full of artifacts / flashes on - off	<ul style="list-style-type: none"> <li>Incorrect placement between the camera module and receiver unit. The camera module and receiver unit do not have line of sight.</li> </ul>	<ul style="list-style-type: none"> <li>Reposition the luminaire.</li> </ul>
The balance arm moves and does not maintain its position after the camera module is removed / added	<ul style="list-style-type: none"> <li>The adjustments of the spring arm are incorrect.</li> </ul>	<ul style="list-style-type: none"> <li>Adjust the spring arm</li> </ul>
Camera module does not turn a full circle	<ul style="list-style-type: none"> <li>All thumb screws are not tightened enough.</li> </ul>	<ul style="list-style-type: none"> <li>Check the thumb screws and tighten them, if necessary.</li> </ul>
Blurry image.	<ul style="list-style-type: none"> <li>The lens of the camera is dirty or damage.</li> </ul>	<ul style="list-style-type: none"> <li>Clean the camera's lens. Contact Merivaara's Customer Care for a replacement lens.</li> </ul>

Table 3. Troubleshooting part 3/3

## 6. TECHNICAL DATA

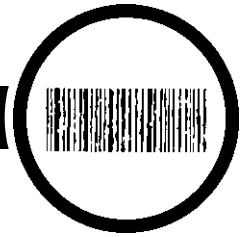

### 6.1 Identification plate

The identification plate is located:

- **SOLO, DUO and TRIO** models on the luminaire yoke and on the ceiling flange.

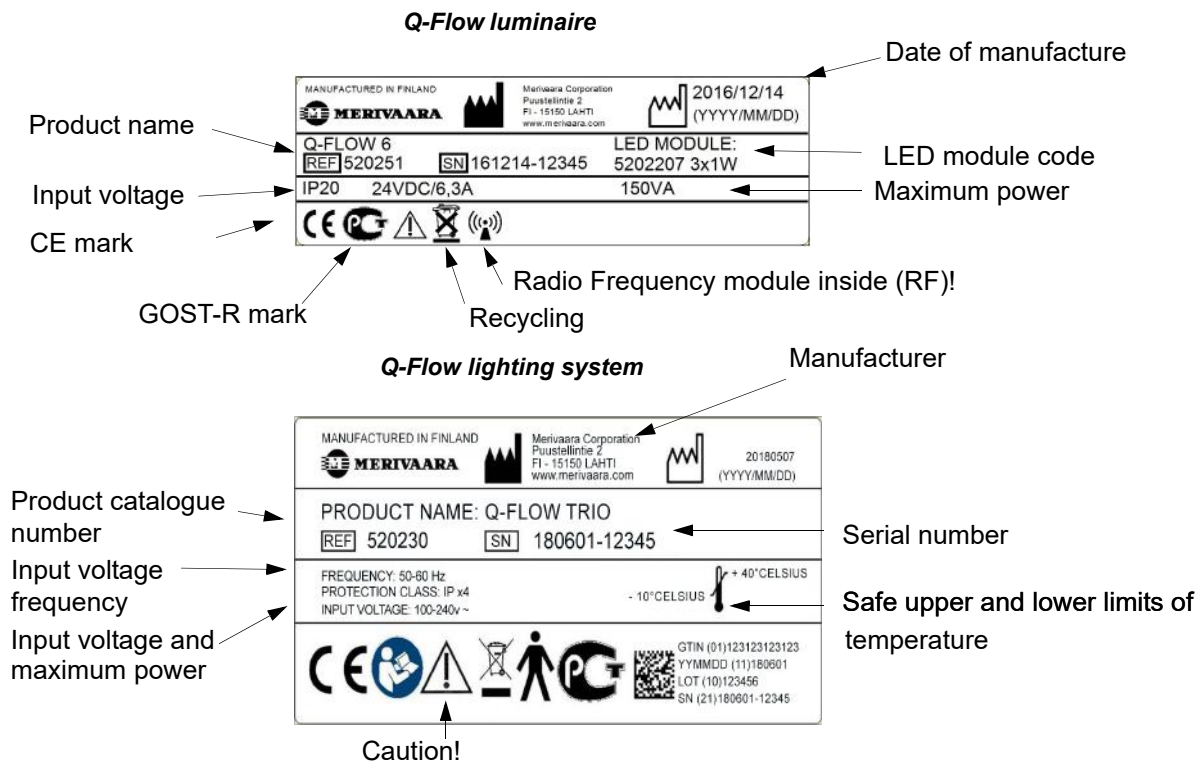

Picture 46. Identification plates of luminaire

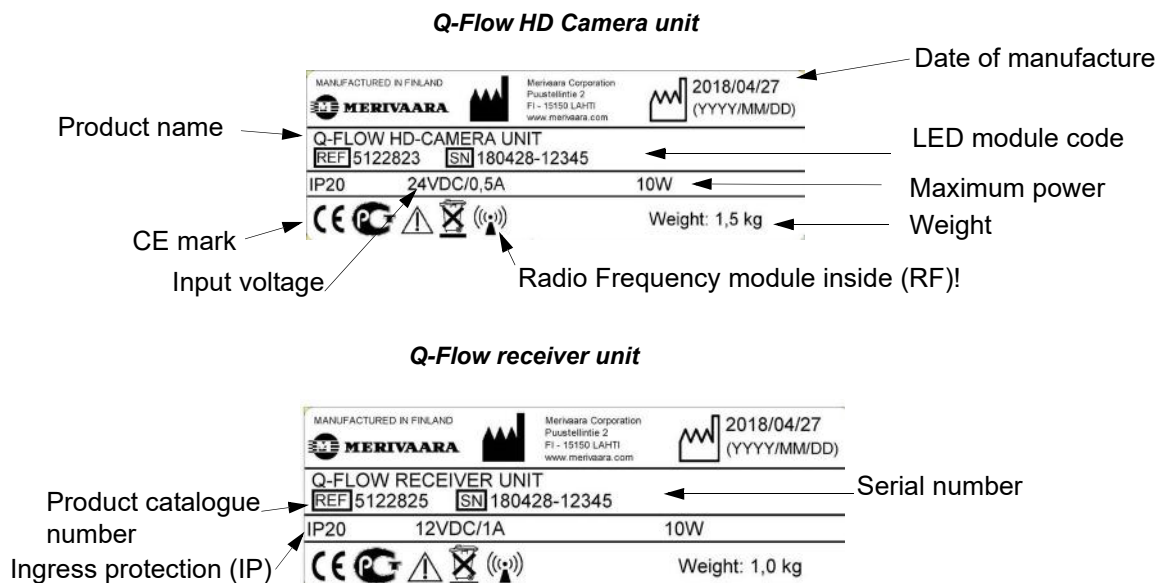

Picture 47. Identification plates of HD camera unit and receiver unit

### 6.1.1 Labelling and symbols used on the product



Protective grounding



Equipotential bonding



Alternating current

I Power ON  
R Power OFF

Main switch of the luminaire



WARNING! Observe to ensure user, maintenance personnel and patient safety.



RECYCLING! Product must be recycled separately!



Follow the instructions for use



B-type device

## 6.1.2 Packaging labels

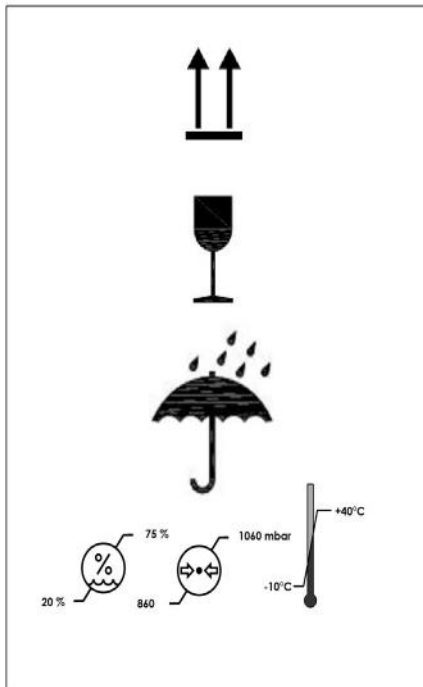

- This way-up
- Fragile
- Keep dry
- Humidity limitation, atmospheric pressure limitation, temperature limits are described in chapter [6.2.1 Environmental Conditions on page 69](#).

		BE	BG	CZ	DK
		DE	EE	IE	EL
ES	FR	HR	IT	CY	LV
LT	LU	HU	MT	NL	AT
PL	PT	RO	SI	SK	FI
SE	UK				

- Restrictions: Allowed only for indoor use"

## 6.2 Specifications

### 6.2.1 Environmental Conditions

Ambient temperature	+10 – +40 °C
Ambient pressure	860–1060 mbar
Relative humidity	20–75%
Temperature of transport	–10 – +40 °C
Temperature of storage	+10 – +40 °C

### 6.2.2 Classification data

Electric shock protection	Class I equipment
Degree of electric protection	B-type
Protection against liquids	IP 20
Input voltage range	100–240 V
Alternating Current, AC	~
AC-frequency range	50–60 Hz
Fuses:	
-Power supply unit	Primary T2A H/250V, 1 pcs Secondary F6.3A L/250V, 2 pcs
-Q-Flow luminaire internal fuses	F6.3A L/125V, 3 pcs

#### RF-module specifications:

- 802.15.4 compliant RF transceiver with Direct Sequence Spread Spectrum (DSSS) including Offset Quadrature Phase Shift Keying (O-QPSK) with half-sine pulse shaping to modulate the RF carrier.
  - frequency band 2.4 GHz
  - max radiated power 1 mW
- |   |   |
|---|---|
| Cleaning and disinfecting                       | Refer to Chapter 4. <u>CLEANING on page 62.</u> |
| Usage type                                      | Continuous use                                  |
| Technical life time (from the date of purchase) | 10 years  |

 **WARNING!** Q-Flow luminaires must not be used on premises where flammable/combustible gases are present!



### 6.2.3 Surface materials

Surface materials
Aluminium casting with powder coating – main body
Aluminium parts with powder coating – covers of body
Aluminium profiles with powder coating – frames of front glasses and arms of pendant
Epoxy powder coated steel base – mobile version base and tubes
PC (Polycarbonate) – front glasses
Silicone rubber – edge trimming of front glasses
PPSU (Polyarylsulphone) – detachable sterilized handle
PC+ABS (Polycarbonate + Acrylonitrile Butadiene Styrene) – touch screen covers and camera modules dome
ABS+PMMA (Acrylonitrile Butadiene Styrene + Poly(Methyl methacrylate coating)) – plastic covers of the Q-Flow Mobile version
PMMA (Polymethyl methacrylate) – lenses
ASA (Acrylonitrile Styrene Acrylate) – covers of balance arms

Table 4. Surface materials

### 6.2.4 Load data

	Vertical load (N) with max. tube length	Maximum bending moment load (Nm)	Maximum limit loads (kg)
Central axis SOLO (Light duty); one extension arm and one spring arm	1220	375	18
Central axis SOLO; one extension arm and one spring arm	920	1090	40
Central axis (DUO 320 - Light duty); two extension arms and two spring arms	1510	740	36
Central axis DUO; two extension arms and two spring arms	1600	2080	80
Central axis TRIO; three extension arms and three spring arms	2280	2630	122

Table 5. Load data

	Total vertical load [N]
Q-Flow SOLO with Q-Flow 4 or 4i	1152
Q-Flow TRIO with Q-Flow 6 series in all arms	1805

Table 6. Examples of total vertical loads of the system in [N]

 **WARNING!** Required regional safety factors must be taken into account with the maximum load data.

## 6.2.5 Luminaire specifications

	Q-Flow 6i	Q-Flow 6	Q-Flow 4i	Q-Flow 4
Colour rendering index (Ra)*	98	98	98	98
Red colour rendering index (R9)*	99	99	99	99
Skin colour rendering index (R13)*	99	99	99	99
Illumination intensity Ec at 1m distance (lx)	160 000	160 000	140 000	140 000
Colour temperature (K)**	3800 / 4500	3800 / 4500	3800 / 4500	3800 / 4500
Depth of illumination L1+L2 (mm)@60%, 20%	750 mm, 1700 mm	750 mm, 1700 mm	700 mm, 1400 mm	700 mm, 1400 mm
Working distance (mm)	750– 800 mm	750–1800 mm	700–1700 mm	700–1700 mm
Light field diameter (mm)	200–380 mm	200–380 mm	200–340 mm	200–340 mm
Light field diameter, d50 value (mm), 4500/wide	180 mm	180 mm	170 mm	170 mm
Light field diameter, d10 value (mm), 4500/wide	330 mm	330 mm	310 mm	310 mm
Integrated dimming (%)	10–100%	10–100%	10–100%	10–100%
Electrical focus	2 steps	2 steps	2 steps	2 steps
Turbulence intensity, DIN 1946 (%)	15.9%	15.9%	35%	35%
Total irradiance (W/m <sup>2</sup> )	510 W/m <sup>2</sup>	510 W/m <sup>2</sup>	490 W/m <sup>2</sup>	490 W/m <sup>2</sup>
Dynamic obstacle compensation	Yes	No	Yes	No
Remaining illuminance with one mask (klx), (autom. % / manual %)	110 klx, 100% / 70%	110 klx, - / manual 70%	90 klx, 95% / 65%	90 klx, - / manual 65%
Remaining illuminance with two masks (klx), (autom. % / manual %)	95 klx, 100% / 60%	95 klx, - / manual 60%	80 klx, 95% / 60%	80 klx, - / manual 60%

Table 7. Part 1/3

	Q-Flow 6i	Q-Flow 6	Q-Flow 4i	Q-Flow 4
Remaining illuminance with the tube (klx), (autom. % / manual %)	135 klx, - / manual 85%	135 klx, - / manual 85%	130 klx, - / manual 95%	130 klx, - / manual 95%
Remaining illuminance with the tube and one mask (klx), (autom. % / manual %)	100 klx, 85% / 65%	100 klx, - / manual 65%	90 klx, 95% / 65%	90 klx, - / manual 65%
Remaining illuminance with the tube and two masks (klx), (autom. % / manual %)	95 klx, 85% / 60%	95 klx, - / manual 60%	75 klx, 95% / 55%	75 klx, - / manual 55%
Double yoke	Yes	Yes	Yes	Yes
Optional SOLO single yoke (LCH) for CM or FM	Yes	Yes	Yes	Yes
Sterilizable, detachable focus handle	Yes	Yes	Yes	Yes
Sterile illuminance intensity control	Yes	No	Yes	No
Sterile light field diam. control	Yes	No	Yes	No
Integrated UI touch panel	Yes	Yes	Yes	Yes
Bulb type	LED	LED	LED	LED
Bulb rating (W)	1.0 W / LED	1.0 W / LED	1.0 W / LED	1.0 W / LED
Number of LEDs (pcs)	90	90	69	69
Nominal operating voltage (V)	24 VDC	24 VDC	24 VDC	24 VDC
Average life time of LED	>50 000 h	>50 000 h	>50 000 h	>50 000 h
Colour of casing	White / Grey (RAL 9010 / RAL 7012)	White / Grey (RAL 9010 / RAL 7012)	White / Grey (RAL 9010 / RAL 7012)	White / Grey (RAL 9010 / RAL 7012)
External dimensions (diameter mm)	700 mm	700 mm	560 mm	560 mm

Table 8. Part 2/3

	Q-Flow 6i	Q-Flow 6	Q-Flow 4i	Q-Flow 4
Power supply unit	100-240 VAC / 24 VDC	100-240 VAC / 24 VDC	100-240 VAC / 24 VDC	100-240 VAC / 24 VDC
Heat to light ratio (mW/m <sup>2</sup> lx)	3.07	3.07	2.53	2.53
Power consumption (VA)	150	150	110	110
Integrated power switch	Yes	Yes	Yes	Yes
Battery Back up - Operating time with 27 Ah / 24 VDC battery (h)	optional - 2 h	optional - 2 h	optional - 3 h	optional - 3 h
Ingress protection class	IP 20	IP 20	IP 20	IP 20
Wireless IR-RF remote control unit (Merimote)	optional	optional	optional	optional
OpenOR compatible	Yes	Yes	Yes	Yes
Camera FullHD	optional	optional	optional	optional
Camera 4K (will be available)	optional	optional	optional	optional
Wireless FullHD picture	optional	optional	optional	optional
Camera control in luminaire	optional	optional	optional	optional
Ambilite for endoscopy	Yes	Yes	Yes	Yes
Light combinations	SOLO, DUO, TRIO	SOLO, DUO, TRIO	SOLO, DUO, TRIO	SOLO, DUO, TRIO
Weight of luminaire	16 kg	16 kg	13 kg	13 kg

Table 9. Part 3/3

\*) Tolerance  $\pm 3$ ,

\*\*) Tolerance  $\pm 300$  °K,

measured in test laboratory conditions, EN 60601-2-41

### 6.2.6 RF unit specifications

	Camera module
Wireless 705A	6705A- SIISK63102 and IC: 6705A- SIISK63101
Frequency Range	59.40 GHz to 63.56 GHz
Bandwidth	1.76 GHz per channel
Radiated Power (EIRP)	28 dBm (average)
Transmit Antenna Gain	18 dBi (max)
Antenna type	Directional, Half sphere (120 dec from surface)

Table 10. Electrical specifications of RF unit

### 6.2.7 Electrical specifications of HD camera module (option)

	Camera module
Power Requirements	24 V DC
Power Consumption	10 W
Working distance	750–1700 mm (focus area with max optical zoom)
Dimensions (W x H x D)*2	60.0 x 64.0 x 105.0 mm (2 3/8 x 2 5/8 x 4 1/4 in)
Mass	Approx. 1200 g (Approx. 42.3 oz)

Table 11. Electrical specifications of HD camera module

## 6.2.8 Technical specifications of HD camera

		Camera module
Image Sensor		1/2.3 type Exmor R CMOS
Image Sensor (Number of Effective Pixels)		Approx. 8.93 Mega Pixels (MP)
Signal System	4K	2160p / 29.97
	FHD / HD	1080p / 59.94
Minimum Illumination (50%, High Sensitivity Mode)		Colour: 0.75 lx (F1.8, AGC on, 1/30 s)
Minimum Illumination (50%, Normal Mode)		Colour: 3 lx (F1.8, AGC on, 1/30 s)
Recommended Illumination		100 lx to 100,000 lx
S/N Ratio		–
Shutter Speed		1/1 s to 1/10,000 s, 22 steps
Backlight Compensation		Yes
Aperture Control		16 steps
White Balance		Auto
Lens		12x optical zoom, f = 3.9 mm (wide) to 46.8 mm (tele) F1.8 to F2.0
Digital Zoom		12x (144x with optical zoom)
Focusing System		Auto, Manual
Noise Reduction		Yes (6 steps)
Progressive Scan Mode		Yes
Image Stabilization		No
Digital Output		Yes
Picture Freeze		Yes
Camera Control Interface		VISCA (CMOS 3.1 V level), Baud rate: 9.6 kbps, 19.2 kbps, 38.4 kbps, 57.6 kbps, 115.2 kbps, Stop bit: 1 bit
Power Requirements		6.0 V to 12.0 V DC
Power Consumption		2.9 W (zoom / focus inactive), 3.7 W (zoom / focus active)
Operating Temperature		-5 °C to +60 °C (23 °F to 140 °F)
Storage Temperature		-20 °C to +60 °C (-4 °F to 140 °F)
Operating Humidity		20% to 80%, Absolute humidity: 36 g/m <sup>3</sup>
Storage Humidity		20% to 95%, Absolute humidity: 36 g/m <sup>3</sup>
Dimensions (W x H x D)*2		60.0 x 64.0 x 105.0 mm (2 3/8 x 2 5/8 x 4 1/4 in)
Mass		Approx. 385 g (Approx. 13.6 oz)





### 6.3 Dimensioning and connection diagrams

#### 6.3.1 Q-Flow SOLO ceiling mounted system

#### Q-Flow SOLO single luminaire

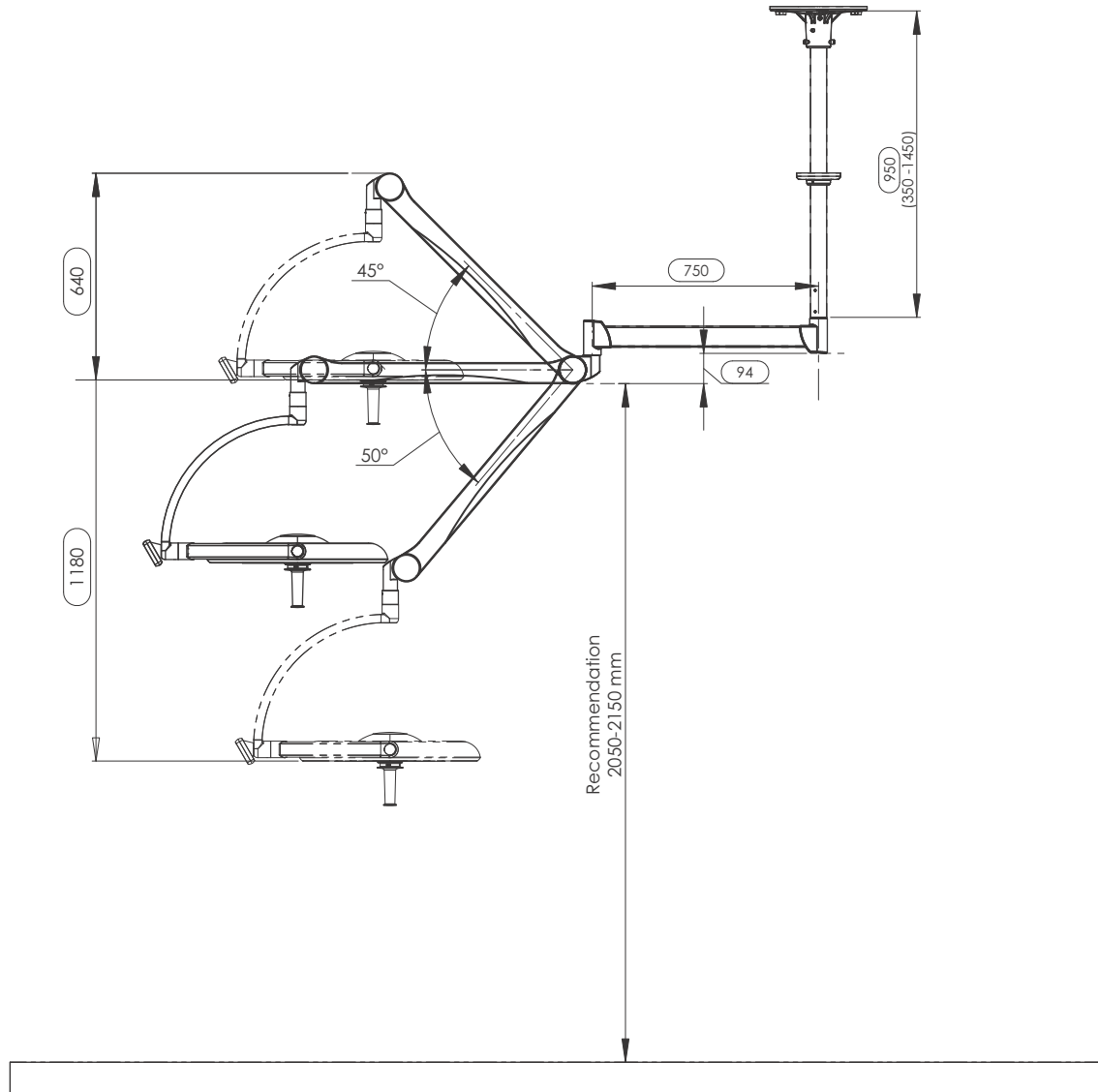

Picture 48. Dimensions of Q-Flow SOLO single luminaire

### 6.3.2 Q-Flow SOLO wall mounted system

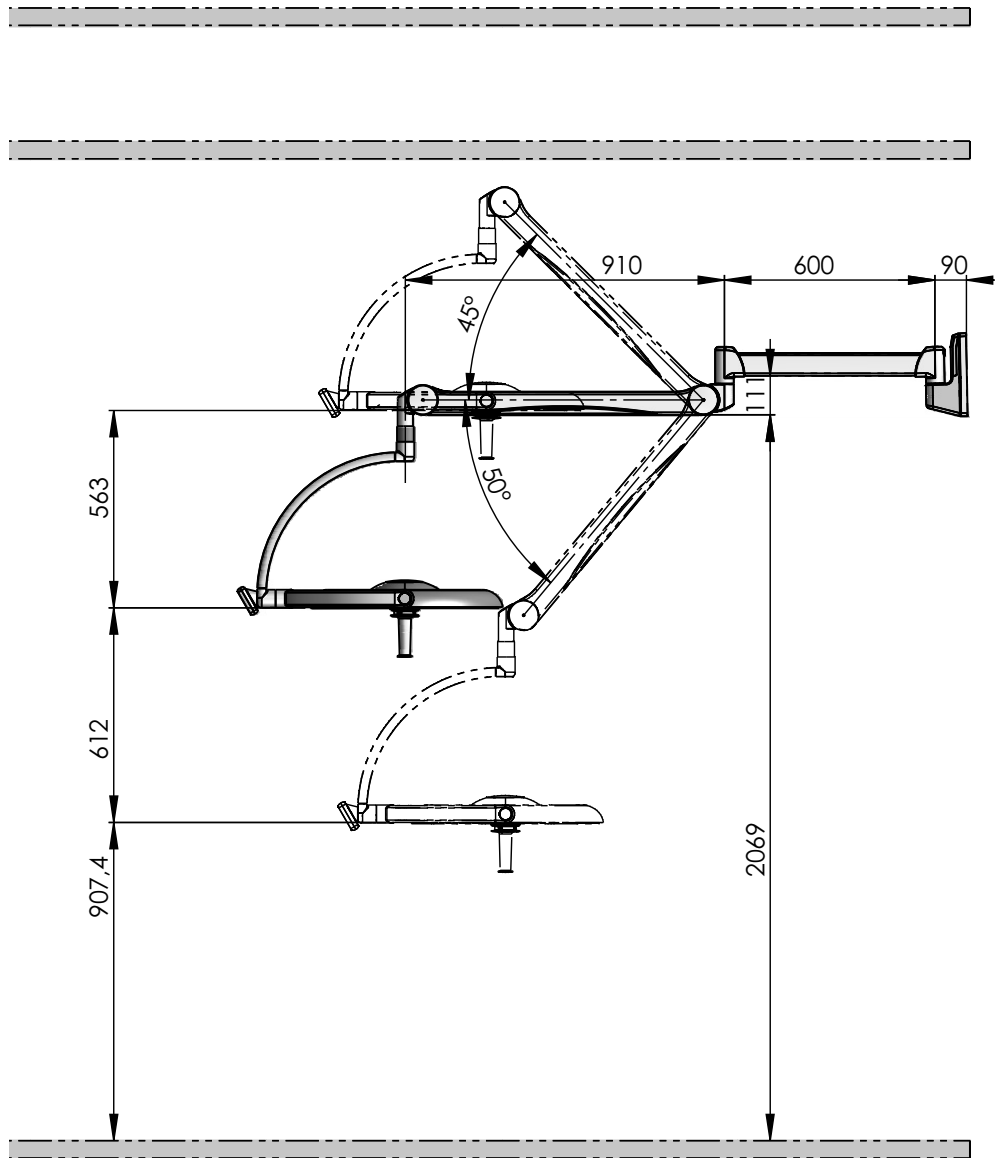

Picture 49. Q-Flow SOLO wall mounted system

### 6.3.2.1 Connection diagram - Q-Flow SOLO lighting systems

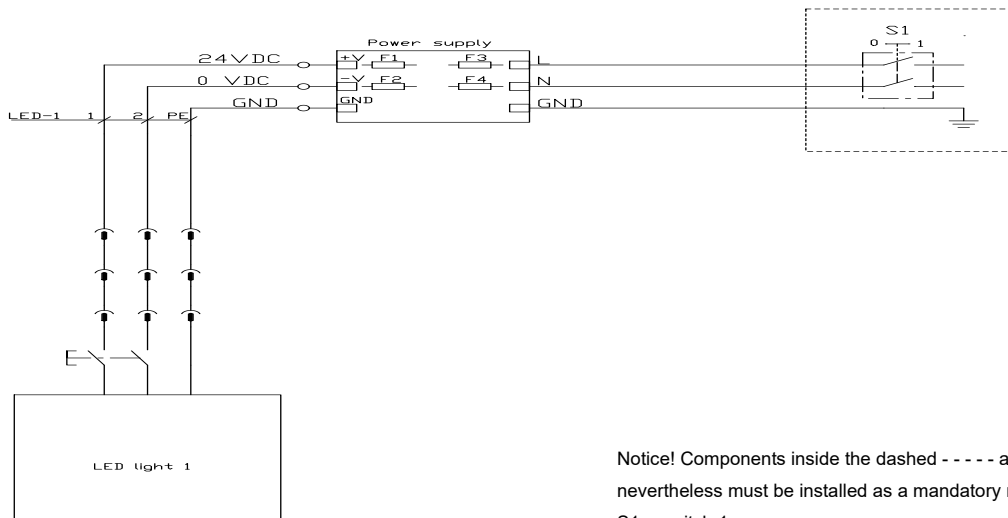

Notice! Components inside the dashed - - - - area not included/ nevertheless must be installed as a mandatory requirement.  
 S1 = switch 1  
 L = Live  
 N = Neutral  
 GND = Ground (Earth)

Picture 50. Connections diagram of Q-Flow SOLO lighting systems

**NOTE!** Merivaara recommends to use primary and secondary wiring at least 2.5 mm<sup>2</sup> cables e.g. MMJ 3 x 2.5 mm<sup>2</sup> or MPLM 3 x 2.5 mm<sup>2</sup>. Recommended maximum cable length is 15 m.

**NOTE!** Installation above illustrated with the fixing method which is described in [3.3.1 Raw ceiling installation on page 14](#). Note that the instructions concern the raw ceiling installation with a 6-point fixing.

**NOTE!** Merivaara does not recommend to connect a diathermy equipment and Q-Flow to the same phase or group.

**WARNING!** Please adhere carefully to the instructions below to successfully complete the system wiring.  
**Connections of the cable coming from the SOLO system ceiling tube:**

- one of the following markings on the wire: no. 2 or RED colour or + (PLUS SIGN) to PSU 24 VDC terminal
- one of the followings markings on the wire: no. 1 or BLACK colour or – (MINUS SIGN) to PSU 0 VDC terminal
- one of the followings markings on the wire: PE or YELLOW-GREEN colour to PSU GND terminal

**NOTE!** The luminaires of the Q-Flow system must always be connected in a such way that there is one power supply unit per luminaire.

### 6.3.3 Q-Flow SOLO ceiling mounted monitor

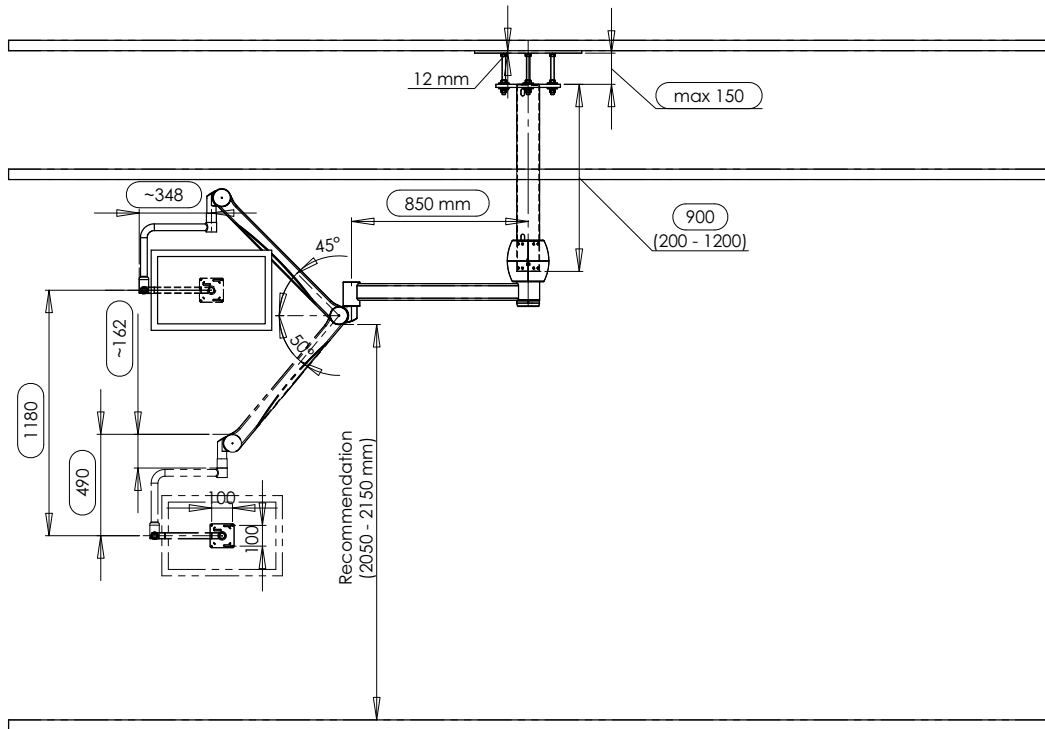

Picture 51. Dimensions of Q-Flow SOLO ceiling mounted monitor

- ! **NOTE!** Merivaara recommends to use primary and secondary wiring at least 2.5 mm<sup>2</sup> cables e.g. MMJ 3 x 2.5 mm<sup>2</sup> or MPLM 3 x 2.5 mm<sup>2</sup>. The recommended maximum cable length is 15 m.
- ! **NOTE!** Installation above illustrated with the fixing method as in section [3.3.1 Raw ceiling installation on page 14](#). Notice, the instructions concern the raw ceiling installation the with 6-point fixing.
- ! **NOTE!** The Q-Flow SOLO monitor or the Q-Flow systems with monitors connected using one power supply unit for each monitor provided by the monitor manufacturer. Connections are made according to the monitor manufacturer instructions. Cabling and the power supply unit are provided with the delivery of the monitor system purchased from the Merivaara Corp.

### 6.3.4 Q-Flow DUO ceiling mounted system

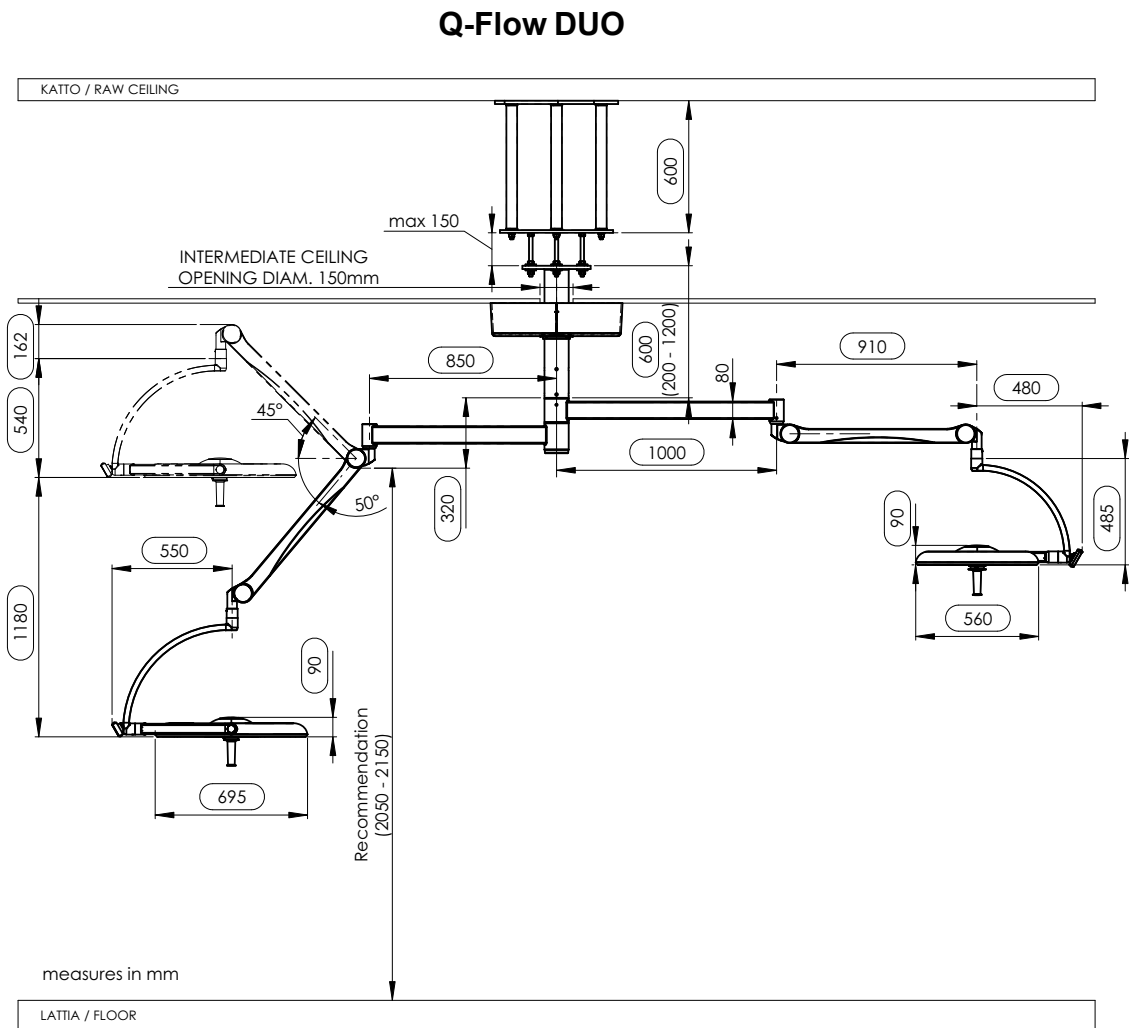

Picture 52. Dimensions of Q-Flow DUO ceiling mounted system

**!** **NOTE!** Installation above illustrated with the fixing method as in section [3.3.2 Raw ceiling installation with intermediate tube set on page 17](#). Notice that the instructions concern the raw ceiling installation with 6-point fixing.

### 6.3.4.1 Q-Flow DUO 360

#### Q-Flow DUO 360

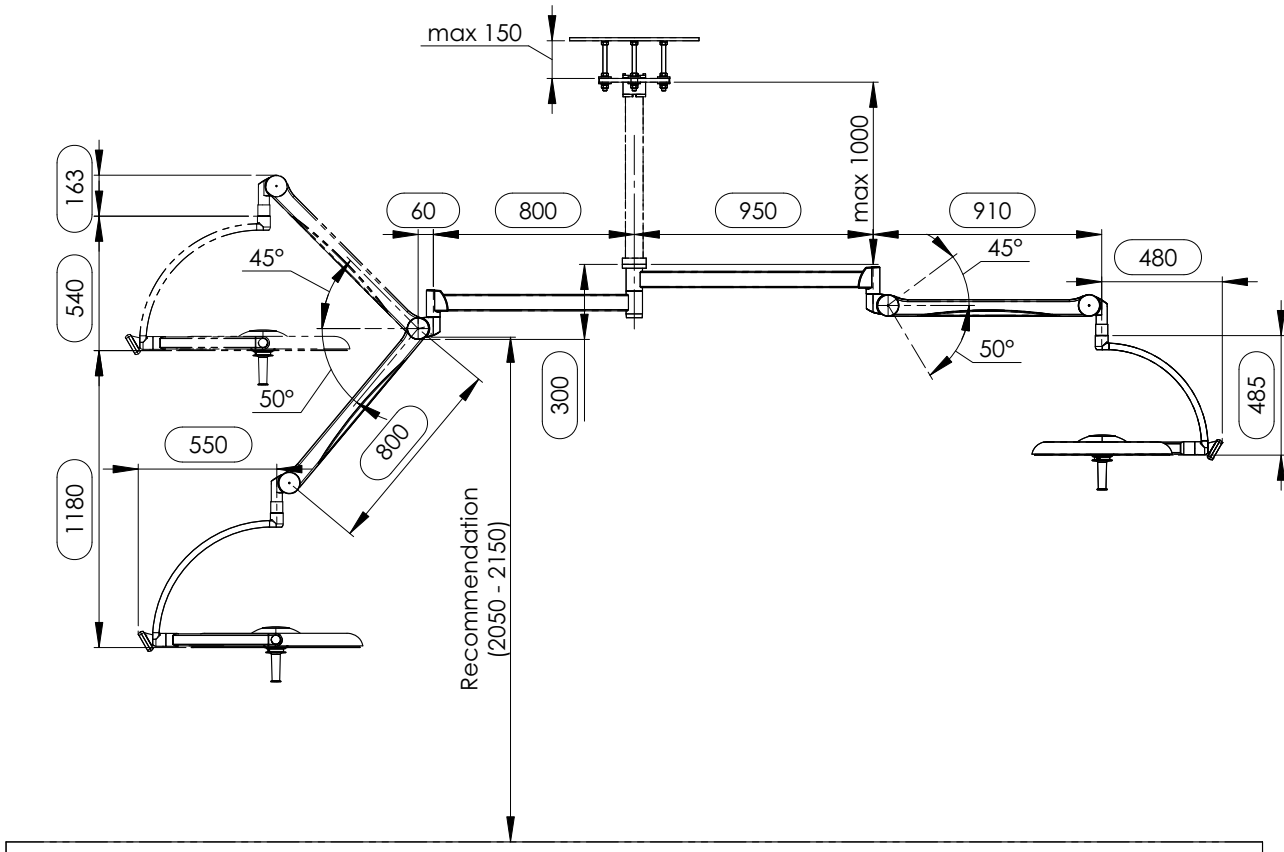

Picture 53. Dimensions of Q-Flow DUO 360

**NOTE!** The installation in the above picture has been made by using the fixing method described in section 3.3.1 Raw ceiling installation on page 14. Note a special type of installation with the 3-point fixing!

6.3.4.2 Q-Flow DUO 320 ceiling mounted system

Q-Flow DUO 320 system

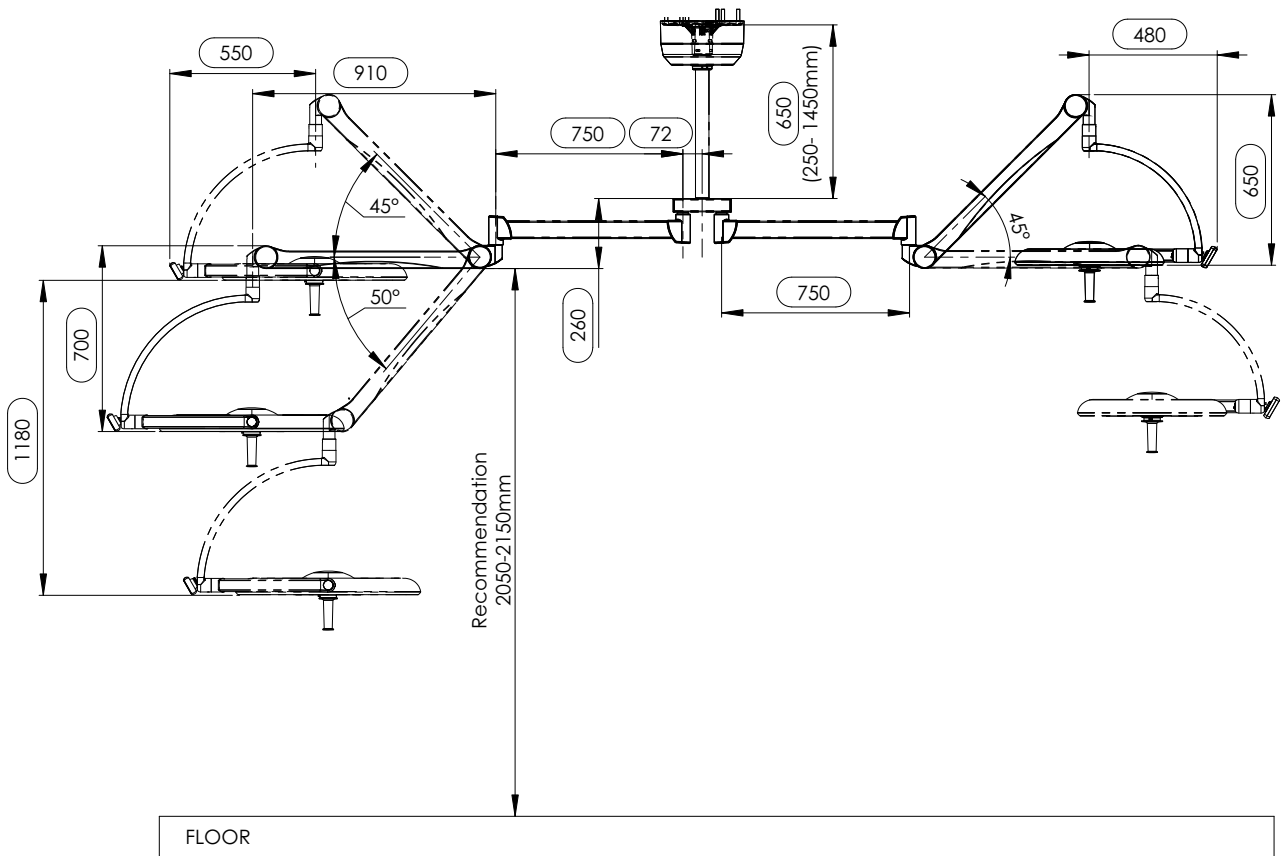

Picture 54. Q-Flow DUO 320 ceiling mounted system

### 6.3.4.3 Q-Flow DUO - Low ceiling height system

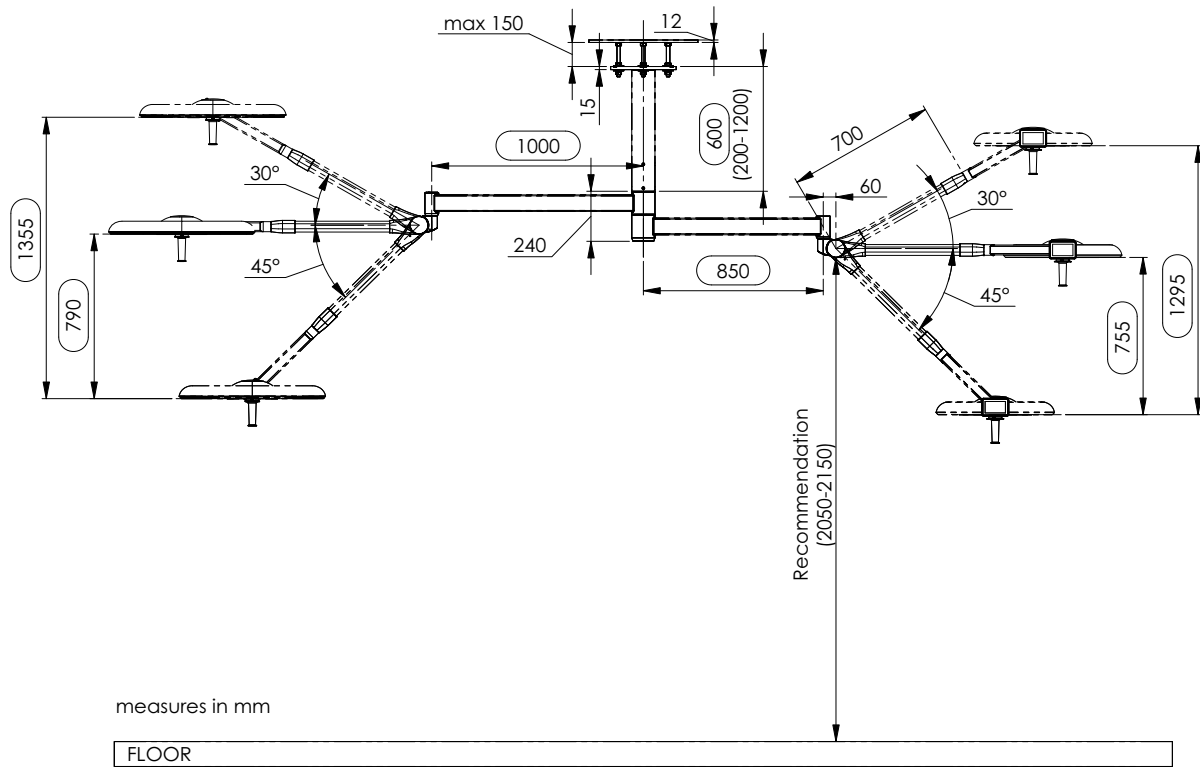

Picture 55. Q-Flow DUO - Low ceiling height



### 6.3.4.4 Connection diagram - Q-Flow DUO and Q-Flow TRIO lighting systems

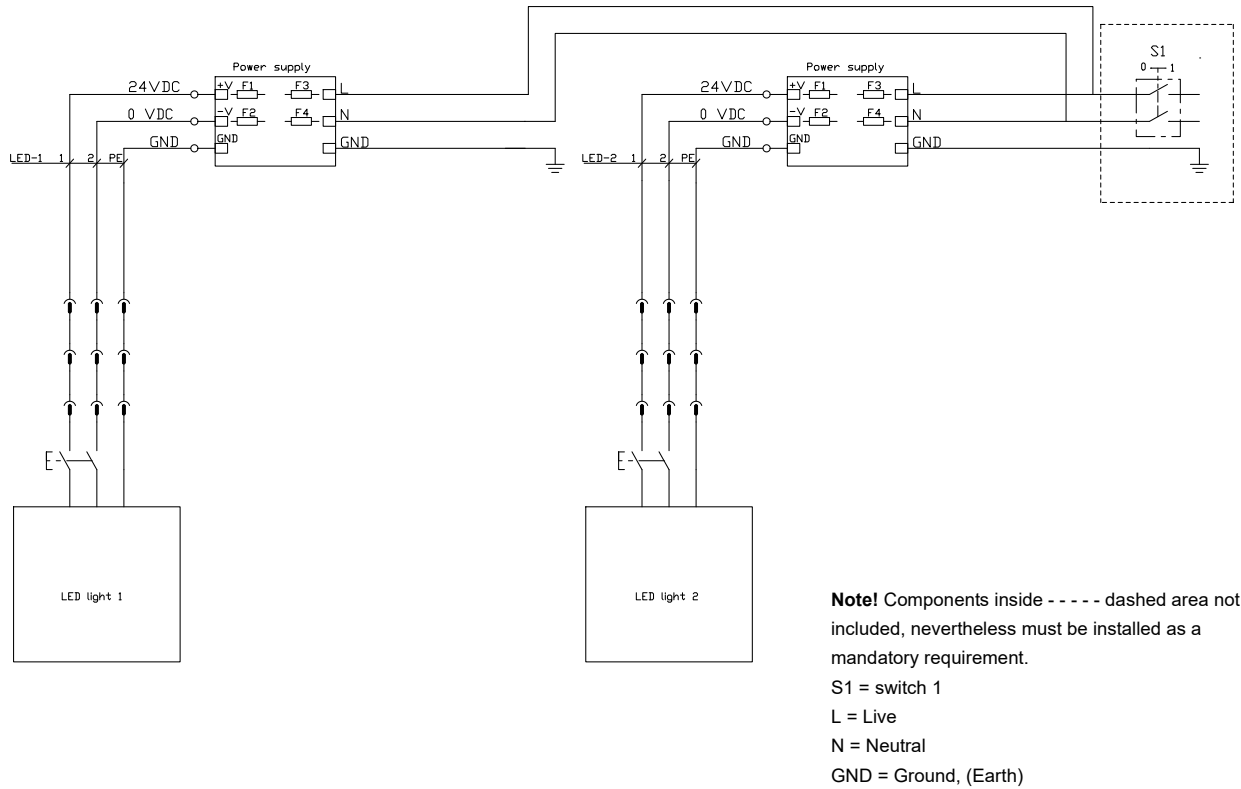

Picture 56. Connection diagram - Q-Flow DUO and Q-Flow TRIO lighting systems

**WARNING!** Follow carefully the instructions below to successfully complete the system wiring.

#### Connections of the cable coming from the DUO system ceiling tube:

- one of the following markings on the wire: no. 2 or RED colour or + (PLUS SIGN) to PSU 24 VDC terminal
- one of the followings markings on the wire: no. 1 or BLACK colour or – (MINUS SIGN) to PSU 0 VDC terminal
- one of the followings markings on the wire: PE or YELLOW-GREEN colour to PSU GND terminal

**NOTE!** The luminaires of the Q-Flow system must always be connected in a such way there is one power supply unit per luminaire.



### 6.3.6 Connection diagram - Q-Flow SOLO, DUO and TRIO ceiling mounted systems with a battery backup BBU (option)

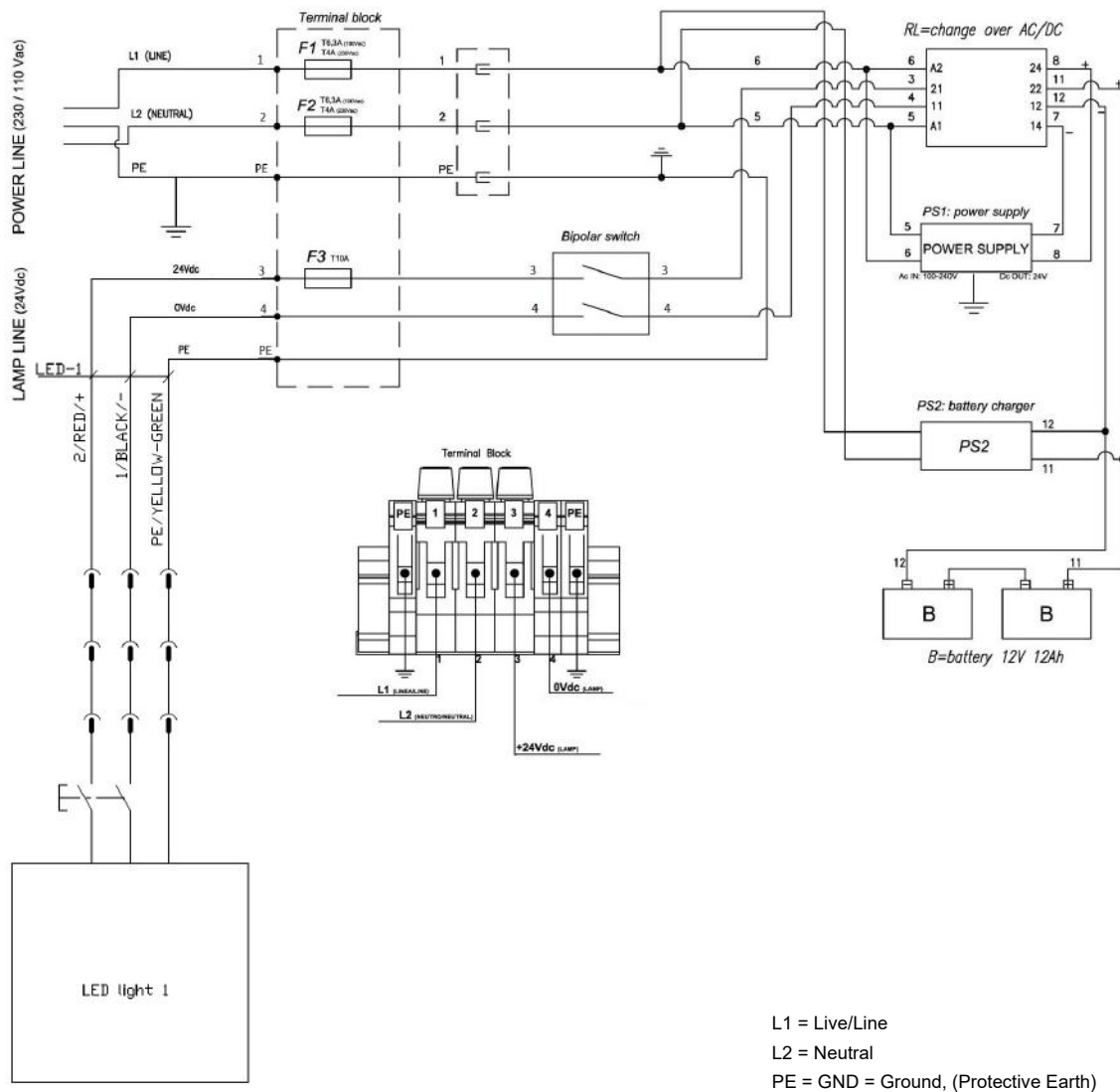

Picture 58. Q-Flow BBU models: 5112844 and 5112845

**WARNING!** Please adhere carefully to the instructions below to successfully complete the system wiring.

#### Connections of the cable coming from the system ceiling tube:

- one of the following markings on the wire: no. 2 or RED colour or + (PLUS SIGN) to PSU 24 VDC terminal
- one of the following markings on the wire: no. 1 or BLACK colour or - (MINUS SIGN) to PSU 0 VDC terminal
- one of the following markings on the wire: PE or YELLOW-GREEN colour to PSU GND terminal



**NOTE!** When using a BBU, the luminaires of the Q-Flow system must always be connected in a such way there is one power supply and battery backup unit per luminaire.

### 6.3.7 Weights of the Q-Flow system components

Model	Q-Flow SOLO Light duty	Q-Flow SOLO Medium duty	Q-Flow DUO 320	Q-Flow DUO Medium duty	Q-Flow TRIO central axis
Weight of ceiling flange / wall mount	3 kg	3 kg	7 kg	7 kg	7 kg
Weight of strengthened ceiling flange (1000mm)	23.2 kg	23.2 kg	23.2 kg	-	-
Weight of intermediate tube system (950mm)	50 kg	50 kg	50 kg	50 kg	50 kg
Weight of vertical arm system (without balance arms)	-	-	30 kg	40 kg	50 kg
Weight of ceiling tube	8 kg/m	8 kg/m	9kg/m	10kg/m	10kg/m
Total weight of articulated and balance arm	10 kg	10 kg	10 kg	-	-
Weight of separate balance arm	-	-	5.5 kg	5.5 kg	5.5 kg
Weight of DUO 320 adapter	-	2.2 kg	-	-	-
Weight of luminaire	4/4i=13 kg, 6/6i=16 kg				

Table 13. Weights of Q-Flow system components

## 7. RECYCLING

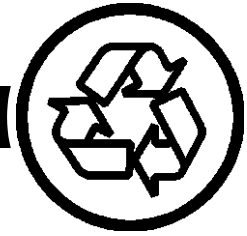

### 7.1 Metals and plastics



**NOTE!** Except for the mobile base, which contains lead gel batteries, the luminaire does not include any hazardous substances. Possible additional battery backup systems should be disposed to each manufacturer's instructions.

When disposing of a luminaire or replacing any of its parts, check the recyclability of each item. Refer [Table 4. Surface materials on page 70](#) to confirm whether or not recycling is possible.

For more information on recycling, contact your local waste management facility or visit related sites on the Internet.

Below are recycling symbols, which are marked on parts made of plastic. Products marked with these symbols can be used as energy waste.



PET



PE - HD



PE - LD



PP



PS



0



**NOTE!** Gel batteries are considered hazardous waste and must therefore be disposed at a hazardous waste facility or according to local requirements.



This symbol is affixed next to the type plate if the product contains an electric or electronic device. The symbol indicates that this product must be recycled/disposed of separately and must not be disposed with general waste.

## 8. USER GUIDANCE FOR EMC

### 8.1 Guidance and manufacturer's declaration - electromagnetic immunity and emissions

The Q-Flow surgical and examination luminaires have been tested according to EN60601-1-2 to ensure proper electromagnetic compatibility. Portable and mobile RF-communications equipment can affect the Q-Flow luminaires. Other products used in the vicinity of the Q-Flow luminaires should also comply with this standard.

Q-Flow surgical luminaires need special precautions regarding EMC and needs to be installed and put into service according to the EMC information provided in this guidance.

Q-Flow surgical luminaires are intended for use in the electromagnetic environment specified in this section.



**WARNING!** ACCESSORIES, transducers and cables other than those specified, with the exception of transducers and cables sold by the Merivaara Corp. as replacement parts for internal components, may result in increased EMISSIONS or decreased IMMUNITY of the Q-Flow surgical lighting system.



**WARNING!** Q-Flow luminaires should not be used adjacent to or stacked with other equipment and that if adjacent or stacked use is necessary the Q-Flow luminaires should be observed to verify normal operation in the configuration in which it will be used.



**WARNING!** ACCESSORY, transducer or cable with the Q-Flow luminaires and the Q-Flow surgical lighting system other than those specified may result in increased EMISSIONS or decreased IMMUNITY of the system.

<b>Guidance and manufacturer's declaration - electromagnetic emissions</b>		
The Q-Flow luminaires are intended for use in the electromagnetic environment specified below. The customer or the user of the Q-Flow luminaires and the system should assure that it is used in the following environment.		
<b>Emissions test</b>	<b>Compliance</b>	<b>Electromagnetic environment - guidance</b>
RF emissions CISPR 11	Group 1	The Q-Flow luminaires and the system uses RF energy only for its internal function. Therefore, its RF emissions are very low and are not likely to cause any interference in nearby electronic equipment.
RF emissions CISPR 11	Class A	The Q-Flow or the Q-Flow system is suitable for use in all establishments other than domestic and those directly connected to the public low-voltage power supply network that supplies buildings used for domestic purposes. The Q-Flow or the Q-Flow system is not suitable for interconnection with other equipment.
Harmonic current emissions IEC/ EN 61000-3-2	Class A	
Voltage changes, fluctuations and flicker IEC/EN 61000-3-3	Complies	

Table 14. Electromagnetic immunity part 1

**Guidance and manufacturer's declaration - electromagnetic immunity**

The Q-Flow luminaires and the system is intended for use in the electromagnetic environment specified below. The customer or the user of the Q-Flow luminaires and the system should assure that it is used in the following environment:

<b>Immunity Test</b>	<b>IEC 60601-1-2 Test Level</b>	<b>Compliance Level</b>	<b>Electromagnetic Environment - guidance</b>
Electrostatic discharge (ESD) IEC 61000-4-2	±6 kV contact ±8 kV air	±6 kV contact ±8 kV air	Floors should be made of wood, concrete, or ceramic tile. If floors are covered with synthetic material, the relative humidity should be at least 30%.
Electrical fast transient/burst IEC 61000-4-4	±2 kV for power supply lines ±1 kV for input/output lines	±2 kV for power supply lines ±1 kV for input/output lines	Mains power quality should be that of a typical commercial or hospital environment.
Surge IEC 61000-4-5	±1 kV line(s) to line(s) ±2 kV line(s) to earth	±1 kV line(s) to line(s) ±2 kV line(s) to earth	Mains power quality should be that of a typical commercial or hospital environment.
Voltage dips, short interruptions, and voltage variations on power supply input lines IEC 61000-4-11	<5% $U_T$ (>95% drop in $U_n$ ) for 0.5 cycle  40% $U_T$ (60% drop in $U_T$ ) for 5 cycles  70% $U_T$ (30% drop in $U_T$ ) for 25 cycles  <5% $U_T$ (>95% drop in $U_T$ ) for 5 seconds	<5% $U_T$ (>95% drop in $U_T$ ) for 0.5 cycle  40% $U_T$ (60% drop in $U_T$ ) for 5 cycles  70% $U_T$ (30% drop in $U_T$ ) for 25 cycles  <5% $U_T$ (>95% drop in $U_T$ ) for 5 seconds	Mains power quality should be that of a typical commercial or hospital environment. If the user of the Q-Flow luminaires and the system requires continued operation during power mains interruptions, it is recommended that the Q-Flow luminaires and the system be powered from an uninterruptible power supply or a battery.
Power frequency (50/60 Hz) magnetic field IEC 61000-4-8	3 A/m	3 A/m	Power frequency magnetic fields should be at levels characteristic of a typical location in a typical commercial or hospital environment.

**NOTE**  $U_T$  is the a.c. mains voltage prior to application of the test level





<b>Guidance and Manufacturer's declaration - electromagnetic immunity</b>			
The Q-Flow luminaires and the system is intended for use in the electromagnetic environment specified below. The customer or the user of the Q-Flow luminaires and the system should assure that it is used in the following environment:			
<b>Immunity test</b>	<b>IEC 60601 test level</b>	<b>Compliance level</b>	<b>Electromagnetic environment - guidance</b>
RF Common mode/ Conducted Susceptibility IEC 61000-4-6  Radiated RF Electromagnetic Field IEC 61000-4-3	3 Vrms 150 kHz to 80 MHz  3 V/m 80MHz to 2.5GHz	3 V  3 V/m	Portable and mobile RF communications equipment should be used no closer to any part of the Q-Flow luminaire, including cables, than the recommended separation distance calculated from the equation applicable to the frequency of the transmitter. Recommended separation distance  $d = 1.2 \sqrt{P}$  $d = 1.2 \sqrt{P}$ 80 MHz to 800 MHz $d = 2.4 \sqrt{P}$ 800 MHz to 2.5 GHz  Where P is the maximum output power rating of the transmitter in watts (W) according to the transmitter manufacturer and d is the recommended separation distance in meters (m).  Field strengths from fixed RF transmitters, as determined by an electromagnetic site survey, <sup>a</sup> should be less than the compliance level in each frequency range. <sup>b</sup>  Interference may occur in the vicinity of equipment marked with the following symbol.  
<b>NOTE 1</b> At 80MHz and 800MHz, the higher frequency range applies. <b>NOTE 2</b> These guidelines may not apply in all situations. Electromagnetic propagation is affected by absorption and reflected from structures, objects and people.			

Table 16. Electromagnetic immunity part 2

- <sup>a</sup> Field strengths from fixed transmitters, such as base stations for radio (cellular/cordless) telephones and land mobile radios, amateur radio, AM and FM radio broadcast and TV broadcast cannot be predicted theoretically with accuracy. To assess the electromagnetic environment due to fixed RF transmitters, an electromagnetic site survey should be considered. If the measured field strength in the location in which the Q-Flow luminaires are used exceeds the applicable RF compliance level above, the Q-Flow luminaire should be observed to verify normal operation. If abnormal performance is observed, additional measures may be necessary, such as reorienting or relocating the Q-Flow luminaire
- <sup>b</sup> Over the frequency range 150 kHz to 80 MHz, field strengths should be less than 3 V/m.

Table 17. Electromagnetic immunity part 3

<b>Recommended separation distance between portable and mobile RF communications equipment and the Q-Flow luminaires and the system.</b>			
The Q-Flow luminaires and the system is intended for use in the electromagnetic environment in which radiated RF disturbances are controlled. The customer or the user of the Q-Flow luminaires and the system can help prevent electromagnetic interference by maintaining a minimum distance between portable and mobile RF communications equipment (transmitters) and the Q-Flow luminaires and the system as recommended below, according to the maximum output power of the communications equipment.			
Rated maximum output power of transmitter W	Separation distance according to frequency of transmitter		
	m		
	150 kHz to 80 MHz $d = 1.2 \sqrt{P}$	80 MHz to 800 MHz $d = 1.2 \sqrt{P}$	800 MHz to 2.5 GHz $d = 2.4 \sqrt{P}$
<b>0.01</b>	0.12	0.12	0.24
<b>0.1</b>	0.38	0.38	0.76
<b>1</b>	1.2	1.2	2.4
<b>10</b>	3.8	3.8	7.6
<b>100</b>	12	12	24
For transmitters rated at a maximum output power not listed above, the recommended separation distance $d$ in meters (m) can be estimated using the equation applicable to the frequency of the transmitter, where $P$ is the maximum output power rating of the transmitter in watt (W) according to the transmitter manufacturer.			
<b>Note 1</b> At 80 MHz and 800 MHz, the separation distance for the higher frequency range applies.			
<b>Note 2</b> These guidelines may not apply in all situations. Electromagnetic propagation is affected by absorption and reflection from structures, objects and people.			

Table 18. Recommended separation distance







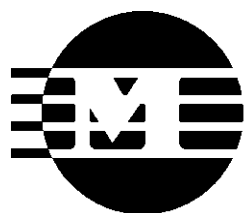

**MERIVAARA**

PDM Nr:	T404230	Rev Nr:	6	Pvm – Date:	04.03.2019
Laatija: Written by:	E. Autti-Ahrnberg, M. Haapaniemi	Hyväksyjä: Accepted by:	Tuotemuutostiimi		

## Q-Flow | Site Preparation Manual

---



PDM Nr:	T404230	Rev Nr:	6	Pvm – Date:	04.03.2019
Laatija: Written by:	E. Autti-Ahrnberg, M. Haapaniemi	Hyväksyjä: Accepted by:	Tuotemuutostiimi		

## 1. Party responsibilities

### Hospital:

1. Provide all architectural drawings in dwg/dxf/pdf/bmp format.
2. A hospital structural engineer must approve the mounting location and method that are provided in this manual. The structural engineer signature must sign the document T404360 for approval.
3. Provide access to the installation site.
4. Specify detailed device locations for project engineering.
5. Prepare the site according the instructions given in this document.
6. Provide electrical cabling, cable conduits and outlets as specified in this document.
7. Provide and run/pull all cables outside of the operating room.
8. Connect electrical circuits according to instructions provided in this document. Only a licensed electrician is allowed to make the connections.
9. Before the installation, ensure that the other manufacturer's equipment that is connected to the *Merivaara* Q-Flow system is on site and it functions.
10. Dust-causing work, painting and flooring must be complete before the installation date.
11. Ensure that the technical areas that will house the power supply systems are ready and no other trades (for example, electrician or IT personnel) need access to the area.
12. Provide removal of trash.
13. Sign and return the *Installation Acceptance Form* after the installation of the Q-Flow system is completed.
14. If the OpenOR system is included, please refer to OpenOR specific Site Preparation document.

PDM Nr:	T404230	Rev Nr:	6	Pvm – Date:	04.03.2019
Laatija: Written by:	E. Autti-Ahrnberg, M. Haapaniemi			Hyväksyjä: Accepted by:	Tuotemuutostiimi

**Merivaara:**

1. Provide the site-specific drawings.
2. Provide requirements for electrical, structural, data, and other relevant details outlined in this document.
3. Unpack the equipment.
4. Pull low voltage cabling for the Q-Flow system within the Operating Room. Only a licensed electrician is allowed to make the connections.
5. Insert cables into connectors.
6. Label the cables .
7. Collect the trash and broken down boxes to an agreed location.
8. Perform the final system testing to ensure that requirements for hospital approval have been met.
9. Deliver Instructions of use and project documentation after hospital approval.

## 2. Site Preparation Instructions

The installation site has to fulfil the following site preparation requirements (ref. ID) for installing the Q-Flow surgical light system and to achieve correct functionality. The requirements must be provided and accepted before the installation.

**General**

ID	Specification
1	Environment: Dust free, Temperature: +10 ... +30 °C, Humidity: 10% ... 85% Q-Flow Power supply unit: maximum operating temperature +70 °C, maximum power output: 150 VA, efficiency: 0.93, maximum heating power: approximately 10 W <b>NOTE!</b> This information applies only for the Q-Flow Power supply unit. When electrical motors or inductive loads are installed to the same area, they must be installed electrically separately and behind a different isolation transformer to prevent unnecessary mains voltage fluctuations

PDM Nr:	T404230	Rev Nr:	6	Pvm – Date:	04.03.2019
Laatija: Written by:	E. Autti-Ahrnberg, M. Haapaniemi			Hyväksyjä: Accepted by:	Tuotemuutostiimi

2	<p>Electricity:</p> <p>Option 1 – 230V/13A AC / 50 – 60Hz supply compliant with IEC60601-2-41:</p> <p>Hard wire electricity 1x 110V/20A – 230V/13A AC / 50-60 Hz. Electrical outlets 230 VAC, medical UPS provided in accordance with IEC/EN 60601-2-41, the maximum distance is 1 meter from the ceiling flange.</p> <p>Option 2 – Remote Back-up UPS installation:</p> <p>2 x cable conduits with a minimum of 1 meter from ceiling flange to the UPS battery back-up location.</p> <p>Conduits have a minimum of 32 mm diameter, a minimum bending radius of 80 mm, with pulling wire terminated to the 2 x installation box, plastic with installation screw spacing of 60 mm, and blanking plate.</p> <p>The maximum length of the cable conduit from a device (ID) to UPS location is 20 m</p> <p>At Battery backup location:</p> <p>1x 110V/20A – 230V/13A AC / 50-60 Hz. Electrical outlets 230 VAC</p> <p>NOTE! Consult your Merivaara project manager for the suitable options (1 or 2) for your installation.</p> <table style="width: 100%; border-collapse: collapse;"> <thead> <tr> <th style="text-align: left;">Cable length</th> <th style="text-align: left;">Minimum cable cross section</th> </tr> </thead> <tbody> <tr> <td>x &lt; 25 m</td> <td>2.5 mm<sup>2</sup> copper wire</td> </tr> <tr> <td>25 m &lt; x &lt; 40 m</td> <td>4.0 mm<sup>2</sup> copper wire</td> </tr> <tr> <td>40 m &lt; x &lt; 60 m</td> <td>6.0 mm<sup>2</sup> copper wire</td> </tr> <tr> <td>60 m &lt; x &lt; 100 m</td> <td>10.0 mm<sup>2</sup> copper wire</td> </tr> </tbody> </table> <p><b>Note!</b> In areas with 0,1 Ω PE resistance requirements it is recommended to use an additional 6 mm<sup>2</sup> earth connection cable to ensure the low PE resistance.</p> <p><b>NOTE!</b> For each Q-Flow surgical light, please refer to site-specific drawings and schematics for project specific number of lights.</p> <p><b>NOTE!</b> For each surgical monitor, please refer to site-specific drawings for project specific number of monitors.</p> <p><b>NOTE!</b> Please refer to Installation and maintenance manual section <i>Dimensioning and connection diagrams</i> for detailed connection diagrams.</p>	Cable length	Minimum cable cross section	x < 25 m	2.5 mm <sup>2</sup> copper wire	25 m < x < 40 m	4.0 mm <sup>2</sup> copper wire	40 m < x < 60 m	6.0 mm <sup>2</sup> copper wire	60 m < x < 100 m	10.0 mm <sup>2</sup> copper wire
Cable length	Minimum cable cross section										
x < 25 m	2.5 mm <sup>2</sup> copper wire										
25 m < x < 40 m	4.0 mm <sup>2</sup> copper wire										
40 m < x < 60 m	6.0 mm <sup>2</sup> copper wire										
60 m < x < 100 m	10.0 mm <sup>2</sup> copper wire										

PDM Nr:	T404230	Rev Nr:	6	Pvm – Date:	04.03.2019
Laatija: Written by:	E. Autti-Ahrnberg, M. Haapaniemi			Hyväksyjä: Accepted by:	Tuotemuutostiimi

3	<p>Supported video output connection type: SDI (applies only for a model with an integrated HD camera)</p> <ul style="list-style-type: none"> <li>• Coaxial cable 75 <math>\Omega</math> nominal impedance with a 75 <math>\Omega</math> male BNC connector (for example: Belden 1855ECH, COAX MINI RG59/U LSZH-C PRECISION VIDEO)</li> </ul> <p>RF receiver:</p> <ul style="list-style-type: none"> <li>• 230 Vac for transformer</li> <li>• Space for the transformer. The cable from the transformer to RF receiver is 950 mm.</li> <li>• SDI cable from video system to the RF receiver</li> </ul> <p>The location of the RF-receiver must be at the ceiling next to the central axis or at the wall with a direct visual line of sight to the light unit. Ceiling installation must be in the same space with the light units, not between the raw ceiling and intermediate ceiling. The wall installation must be next to the wall of the technical room so that the video cable is as short as possible.</p> <p>Size of the RF receiver: 180 mm x 180 mm x 50 mm. Refer to the drill guide in the <i>Q-Flow Installation and Maintenance Manual DO1140</i>.</p> <p>Size of the transformer: 125 mm x 50 mm x 30 mm</p>
---	---

### Mechanical

- Room dimensions:
  - o The Q-Flow system is provided according to the room height, width and length. The customer is responsible for the design of the room and that the collisions between the existing/provided equipment and Q-Flow system are minimized..
  - o The length of the ceiling tube is provided according to the Q-Flow system room height. Please refer to Q-Flow Installation and maintenance manual D01140, section *Selecting proper ceiling tube height* for ordering a suitable ceiling tube.
- Ceiling installation:
  - o Responsibility for ceiling installation:
    - The interface plate with threaded rods or the intermediate tube set are installed into the raw ceiling by the hospital or the contractor. Only

PDM Nr:	T404230	Rev Nr:	6	Pvm – Date:	04.03.2019
Laatija: Written by:	E. Autti-Ahrnberg, M. Haapaniemi			Hyväksyjä: Accepted by:	Tuotemuutostiimi

authorized personnel\* can install the interface plate and the threaded rods that hold the actual ceiling flange with a ceiling tube. Refer to figures in Appendix A to view the illustrations of both installation methods.

\* The following personnel are considered as authorized personnel: The qualified technical person / technician belonging to personnel of a customer / product owner, or a third party authorised by the customer / owner with qualifications and licenses. The person who is responsible for the installation must be also trained by an authorized representative designated by *Merivaara Corporation*.

**WARNING!** If the installation is not done properly, the whole Q-Flow system can fall.

o Documentation for ceiling installation

- The structural design of the ceiling must ensure that the loads of the Q-Flow system as well as any other loads on the ceiling are absorbed and distributed safely.
- A professional structural engineer must fill in the form in document T404360 to demonstrate that the calculations of ceiling anchorage and the distribution of loads in the ceiling are performed according to engineering standards. A professional structural engineer of a trusted party must be duly registered in the professional register.
- Observe the applicable regional building regulations.
- All installation work must to be carried out according to the regulations and by using appropriate tools.

o Ceiling load requirements:

- **WARNING!** The stipulated regional safety factors must be taken into account with the maximum load data.

Vertical load [N]	Maximum bending moment [Nm]	Maximum limit loads [kg]
2280	2630	122

PDM Nr:	T404230	Rev Nr:	6	Pvm – Date:	04.03.2019
Laatija: Written by:	E. Autti-Ahrnberg, M. Haapaniemi	Hyväksyjä: Accepted by:	Tuotemuutostiimi		

Installation with heavy load anchors:

- Ceiling plate must be installed with four heavy load anchors (refer to Appendix B for further details regarding the anchors). The anchors must be evenly installed around the base circle of 470 millimetres.
- During the concrete pouring stage, install heavy load anchors or threaded rods with screw anchors to the ceiling according to the instructions in this document. If the system is installed into a ceiling that does not have fixings, drill holes for the heavy load anchors. When the purpose of the room changes, arrangement of anchors enables to mount a larger lighting system to the same arrangement..

**WARNING!** In pre-stressed modular structures (such as hollow-core slabs), the location of steel elements must be determined carefully. If even one steel element breaks, it can substantially weaken the structural strength.

- Use only heavy load anchors which have been approved for mounting in the specific tension zone.
- We recommend a heavy load anchor HILTI HST 3 M20 x 170/30 for reinforced concrete ceilings that have been built according to professional standards by using the right materials and tools according to DIN 1045. Refer to Appendix B for further details.
- The interface plate must be flush with the raw ceiling to ensure proper load distribution.
- In wooden ceilings and older buildings in which the strength of the ceiling material is not known, use through-bolting and/or reinforce the ceiling with a separate anchor plate that is attached to the firm sections of the ceiling.

*Merivaara* does not, cannot, and will not accept any legal responsibility for the inappropriate installation or corrupted material or faulty structure of the ceiling.

PDM Nr:	T404230	Rev Nr:	6	Pvm – Date:	04.03.2019
Laatija: Written by:	E. Autti-Ahrnberg, M. Haapaniemi			Hyväksyjä: Accepted by:	Tuotemuutostiimi

## Appendix A: Ceiling mount specifications

### 1. Interface plate installation with a 6 point flange fixing

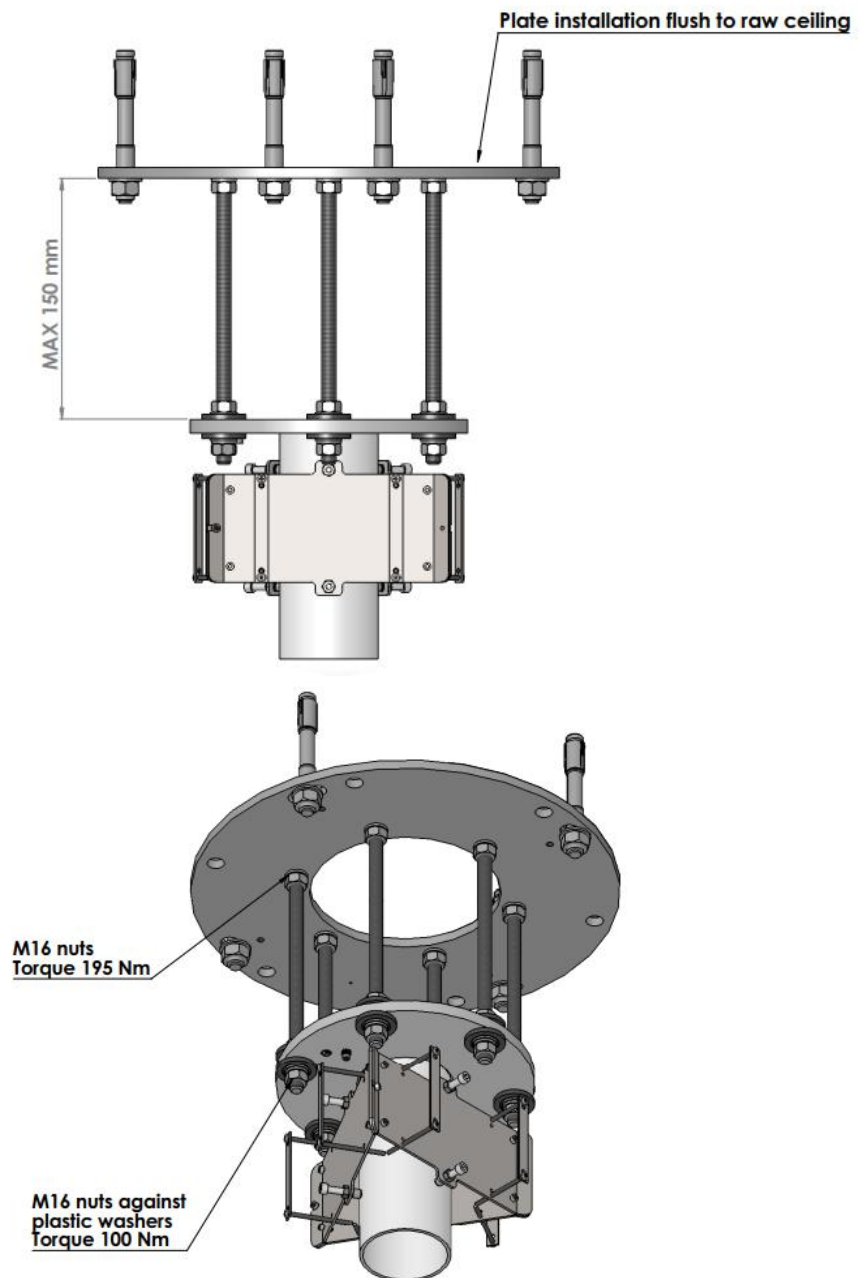

Figure 1: Interface plate with threaded rods installation flush to raw ceiling

**NOTE!** Installations of the flush below the plate installed to raw ceiling must be performed according to Q-Flow installation and maintenance manual DO1140 and by the personnel described in the manual

PDM Nr:	T404230	Rev Nr:	6	Pvm – Date:	04.03.2019
Laatija: Written by:	E. Autti-Ahrnberg, M. Haapaniemi			Hyväksyjä: Accepted by:	Tuotemuutostiimi

## Appendix A: Ceiling mount specifications

### 2. Interface plate installation with a 3 point flange fixing

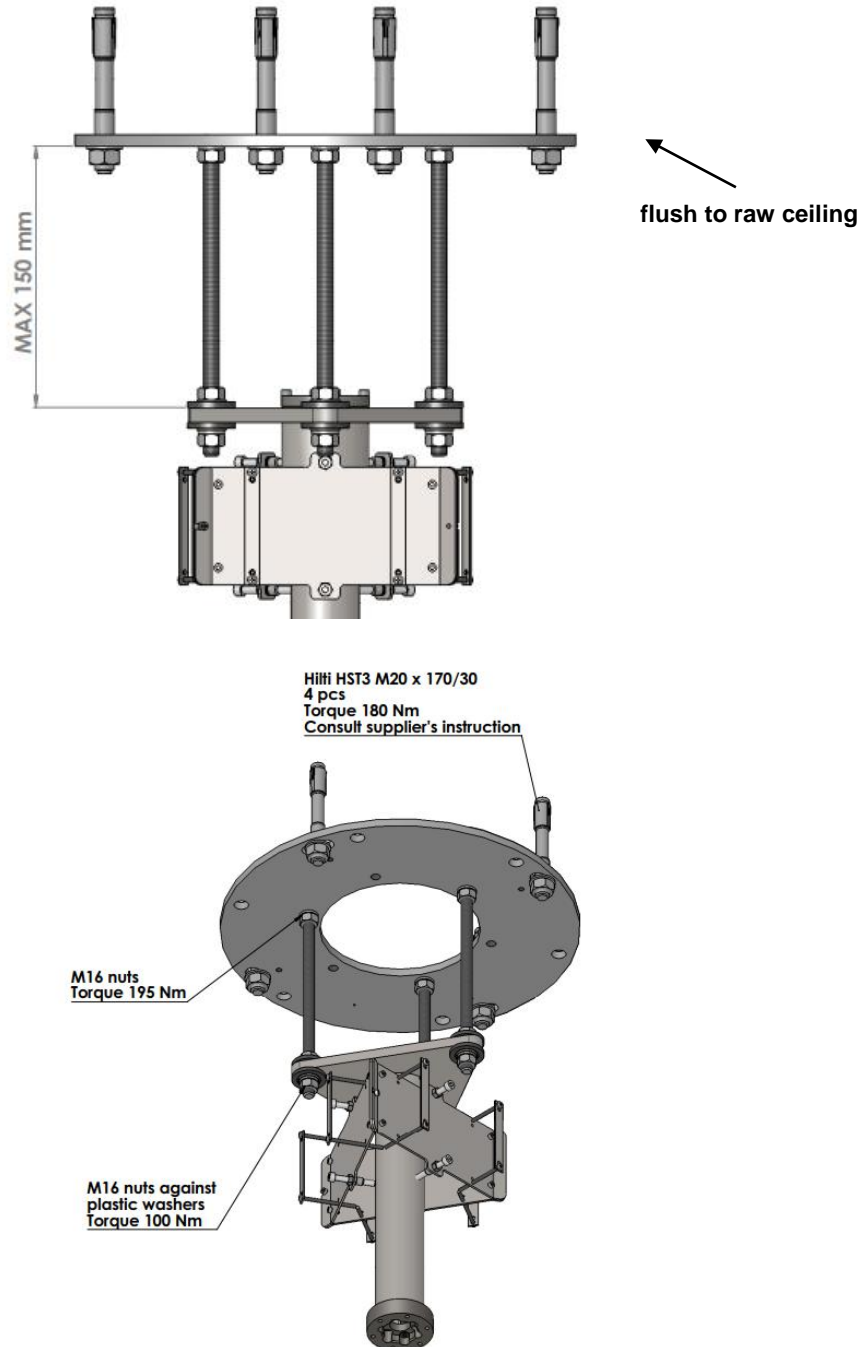

**Figure 2: Interface plate with threaded rods installation flush to raw ceiling**

**NOTE!** Installations of anything below the plate installed flush to raw ceiling must be performed according to Q-Flow installation and maintenance manual by personnel described in the manual



PDM Nr:	T404230	Rev Nr:	6	Pvm – Date:	04.03.2019
Laatija: Written by:	E. Autti-Ahrnberg, M. Haapaniemi			Hyväksyjä: Accepted by:	Tuotemuutostiimi

## Appendix A: Ceiling mount specifications

### 3. Intermediate tube set with interface plate

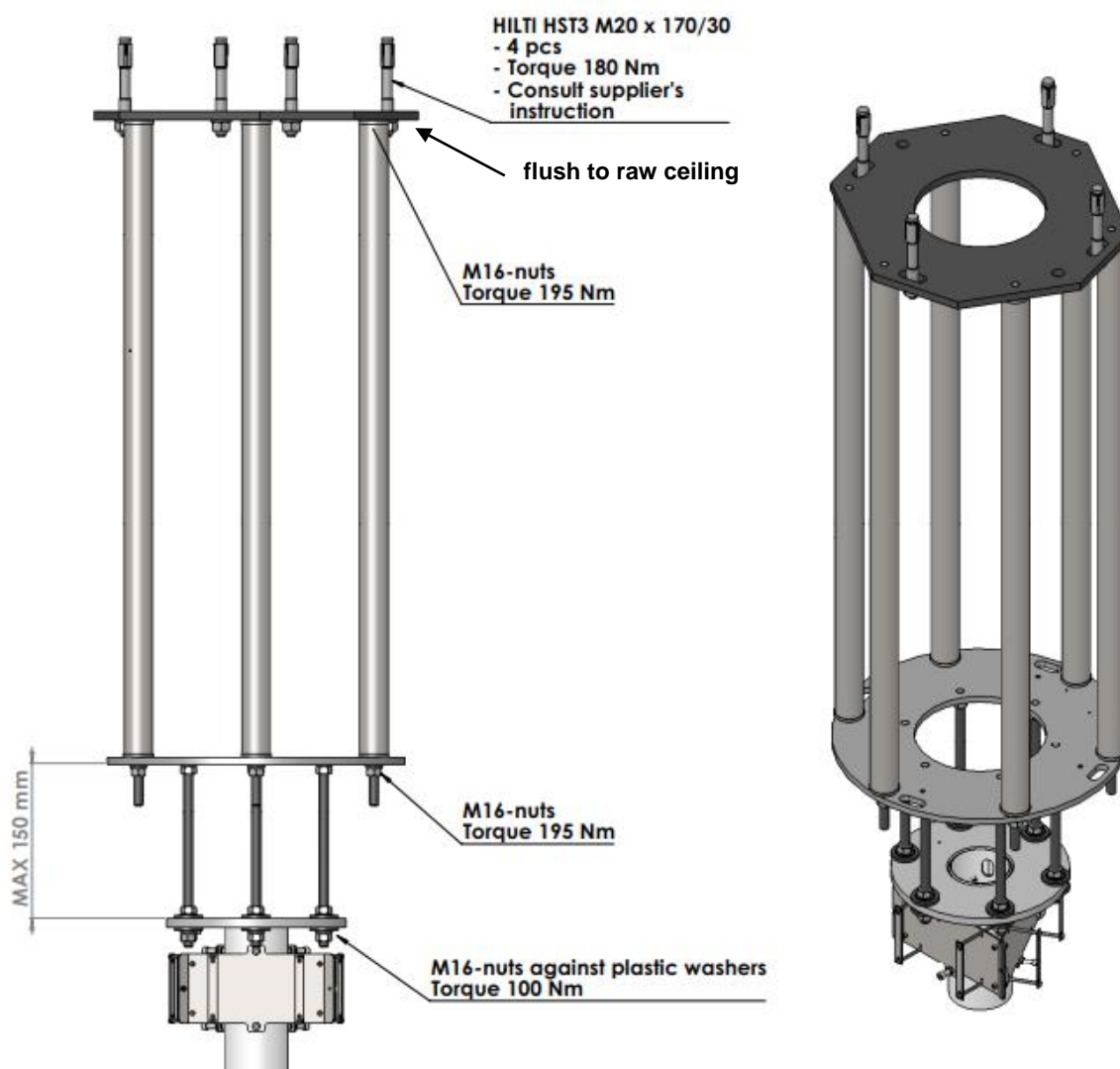
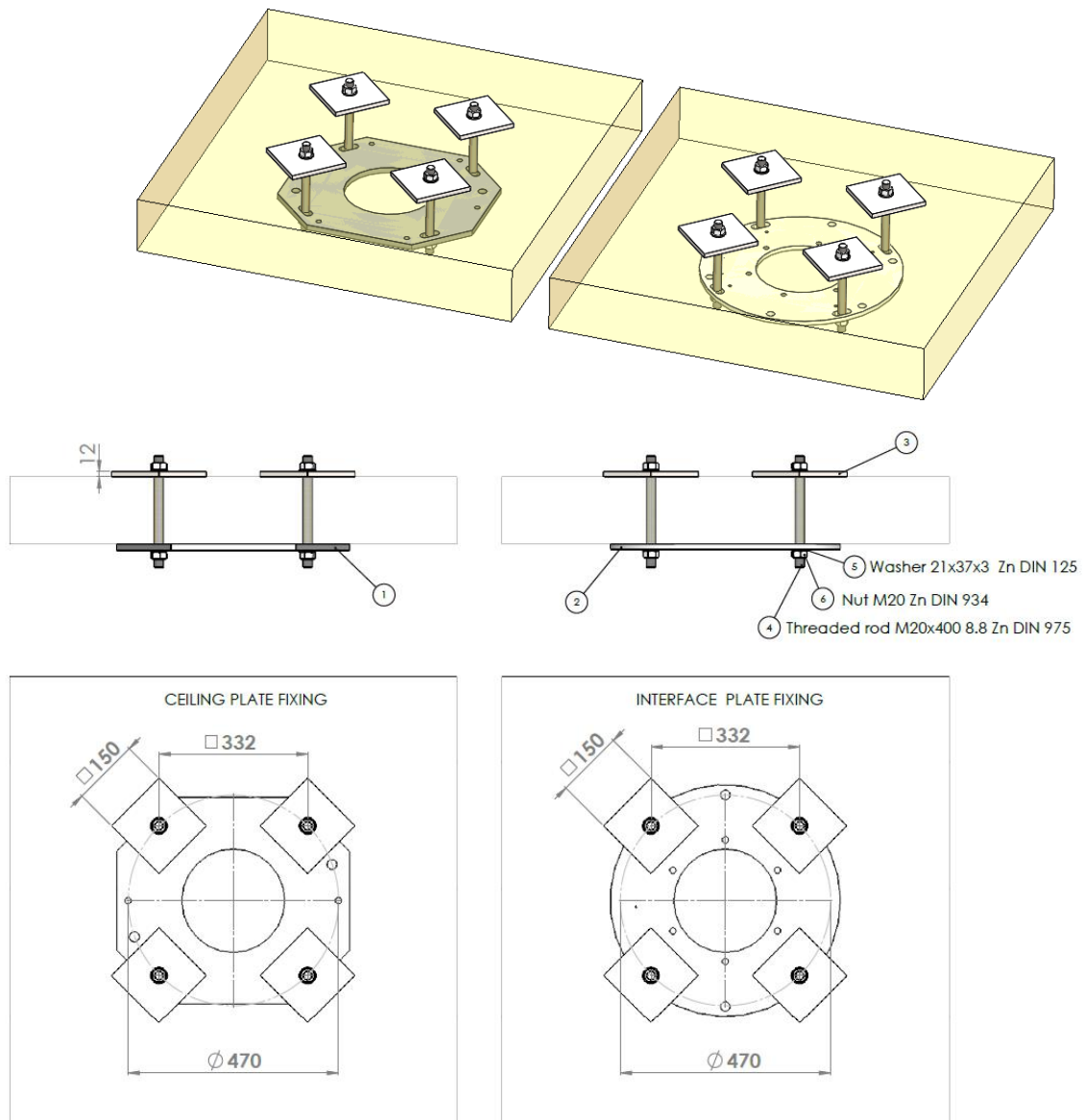

**Figure 3: Installation with the intermediate tube set**

**NOTE!** Installations of anything below the plate installed flush to raw ceiling must be performed according to the Q-Flow installation and maintenance manual by the personnel described in the manual

PDM Nr:	T404230	Rev Nr:	6	Pvm – Date:	04.03.2019
Laatija:	E. Autti-Ahrnberg, Written by: M. Haapaniemi			Hyväksyjä:	Tuotemuutostiimi
				Accepted by:	

#### 4. Through bolt fixing of the ceiling and interface plate



#### Important:

- Always use counter plate (steel material) fixing if the concrete ceiling thickness is less than 200 mm
- Diameter of drilled holes is  $\varnothing 21$  mm
- The tightening torque of the M20 nut is 395 Nm

PDM Nr:	T404230	Rev Nr:	6	Pvm – Date:	04.03.2019
Laatija: Written by:	E. Autti-Ahrnberg, M. Haapaniemi			Hyväksyjä: Accepted by:	Tuotemuutostiimi

## Appendix B: HILTI HST 3 M20 x 170/30 heavy load anchor specifications

Copying of this document and giving it to others and the use or communication of the contents thereof are forbidden without express authority. Offenders are liable to the payment of damages. All rights are reserved by Merivaara Oy in the event of the grant of a patent or the registration of a model or design.

Stainless steel material handling according to 14033:85

**Machined version M20 • M24**

Markings:  
HST3: HST3 M ...  $\frac{h_1}{h_2}$ / $\frac{h_1}{h_2}$   
HST3-R: HST3 R M ...  $\frac{h_1}{h_2}$ / $\frac{h_1}{h_2}$

**Setting details**

Anchor size	M8	M10	M12	M16	M20	M24
Nominal diameter of drill bit	8	10	12	16	20	24
Cutting diameter of drill bit	8.45	10.45	12.5	16.5	20.55	24.55
Effective embedment depth	$h_{e1}$ (mm)	40	50	66	85	101
	$h_{e2}$ (mm)	47	60	70	85	101
	$h_{e3}$ (mm)	53	68	86	106	124
Drill hole depth <sup>1)</sup>	$h_{d1}$ (mm)	59	73	88	106	124
	$h_{d2}$ (mm)	59	73	88	106	124
Thread engagement length	$h_{tr1}$ (mm)	48	60	78	98	116
	$h_{tr2}$ (mm)	54	68	80	98	116
Maximum diameter of clearance hole at the failure	$d_f$ (mm)	9	12	14	16	22
	$d_{fmax}$ (mm)	19.5	22.0	27.0	31.0	33.0
Maximum thickness of flange	$t_{flange}$ (mm)	13	17	19	24	30
	$t_{flange}$ (mm)	13	17	19	24	30

<sup>1)</sup> In case of diamond drilling +5 mm for M8 to M10 and +2 mm for M12 to M24.

**Minimum base material thickness 200 mm**  
**Required tightening torque 180 Nm**

HST3,  
HST3-R M20

**1)**

**2)**

**3)**

**4)**

ITEM NO.	ITEM CODE	QTY	ITEM DESCRIPTION 1	ITEM DESCRIPTION 2	SCALE	MASS / KG	PRINTED
DIMENSIONS WITHOUT TOLERANCE							
MATERIAL							
MACHINING: ISO 2768-MS							
WELDING: EN ISO 15620-BE							
SURFACE TREATMENT							
SHEET 1 / 1							
KILJA-ANKKURI HILTI HST3 M20X170-/30							
A43393400-1							

PDM Nr:	T404338	Rev Nr:	2	Pvm – Date:	5.7.2018
Laatija: Written by:	Artem Kozmin / Paul Bärlund			Hyväksyjä: Accepted by:	Jyrki Nieminen

## Installation inspection form - Q-Flow™ system

Product/system:	
Date of installation:	
Serial number:	
Customer reference number:	

Location of installment:		Date of on-site verification:	
--------------------------	--	-------------------------------	--

### Instructions

In this form is presented the inspection measures to be completed at installation stage of the system. For annual maintenance, please use the Annual maintenance inspection form, Annex 2.

In order to guarantee a safe use of the Q-Flow™ lighting system, perform the necessary actions and possible follow-ups before check out the box. The defective or incorrectly installed device must not be used! Note! column is to clarify the details related to the measure in words.

The system must be inspected by the qualified technical person / technician belonging to personnel of a customer / product owner, or a third party authorised by the customer / owner with qualifications and licenses. The person who is responsible for the installation must be also trained by an authorized representative designated by *Merivaara Corporation*.

### Important information

- The inspection intervals must be observed.
- This inspection plan is only valid when combined with this installation and maintenance manual and user instructions of the user manual which must be consulted as complementary reference documents during the inspections.

**Inspection is to be done by following the points specified below:**

	Checked and passed!		Note!
	Ok	No	
<b>Visual inspection</b>			
The parts of the Q-Flow™ system are not deformed and are free from damage (scratches, cracks, etc.)	<input type="checkbox"/>	<input type="checkbox"/>	

PDM Nr:	T404338	Rev Nr:	2	Pvm – Date:	5.7.2018
Laatija: Written by:	Artem Kozmin / Paul Bärlund			Hyväksyjä: Accepted by:	Jyrki Nieminen

The system surfaces are free from defects in paintwork	<input type="checkbox"/>	<input type="checkbox"/>	
The plastic covers are supplied and correctly positioned	<input type="checkbox"/>	<input type="checkbox"/>	
All ID plates and labels are available and readable	<input type="checkbox"/>	<input type="checkbox"/>	
All the screws and protective covers are supplied and properly installed	<input type="checkbox"/>	<input type="checkbox"/>	

<b>Functional check</b>	<b>Checked and passed!</b>		<b>Note!</b>
	<b>Ok</b>	<b>No</b>	
The central axis extension arms rotate with ease	<input type="checkbox"/>	<input type="checkbox"/>	
The system components remain in adjusted positions	<input type="checkbox"/>	<input type="checkbox"/>	
The friction brakes have been adjusted properly; re-adjust them if required	<input type="checkbox"/>	<input type="checkbox"/>	
Limit stop (if existing) is properly in place and effective	<input type="checkbox"/>	<input type="checkbox"/>	
Load compensation/spring tension is correct, re-adjust it if required	<input type="checkbox"/>	<input type="checkbox"/>	
All sockets (if existing) have been properly mounted and functioning properly	<input type="checkbox"/>	<input type="checkbox"/>	
The screw type fixings and connections with the torques specified in the Installation and maintenance manual are securely in place	<input type="checkbox"/>	<input type="checkbox"/>	
After 10 years of operation, check the full system visually. If there's any sign of wear or damage in the cables or hoses insulation, replace them immediately.	<input type="checkbox"/>	<input type="checkbox"/>	
Make sure the synchronised control feature of the Q-Flow™ does not control any other Q-Flow™ luminaire in the same building.	<input type="checkbox"/>	<input type="checkbox"/>	
Camera unit (if existing) have been properly mounted and functioning properly	<input type="checkbox"/>	<input type="checkbox"/>	

PDM Nr:	T404338	Rev Nr:	2	Pvm – Date:	5.7.2018
Laatija: Written by:	Artem Kozmin / Paul Bärlund			Hyväksyjä: Accepted by:	Jyrki Nieminen

Receiver unit (if existing) have been properly mounted and functioning properly	<input type="checkbox"/>	<input type="checkbox"/>	
<b>Electrical inspections</b>			
Protective conductor resistance and continuity checked (IEC/EN 62353)	<input type="checkbox"/>	<input type="checkbox"/>	
The compliance of the PSU installation must be verified against given instructions by an licensed electrician.	<input type="checkbox"/>	<input type="checkbox"/>	

### Warranty

Merivaara Corporation (“Merivaara”) hereby warrants this product (Q-Flow™) manufactured by Merivaara to be free from defects in material and workmanship for a period of twenty-four (24) months from the date of delivery from Merivaara to the distributor, or twelve (12) months from the date of delivery from the distributor to the customer, whichever is shorter.

**WARNING!** Disregarding these installation check points will void the warranty and may jeopardize the safety matters concerned which cannot be otherwise guaranteed.

I assure that the mentioned measures are completed in accordance with the requirements given.

<b>Inspector's signature:</b>		
_____	_____	_____
<b>Date</b>	<b>Signature/Stamp</b>	<b>Name</b>
<b>Signature of an authorised representative designated by Merivaara Corporation:</b>		
_____	_____	_____
<b>Date</b>	<b>Signature/Stamp</b>	<b>Name</b>

## T404474: User training guidelines

<b>Product/system:</b>	
<b>Date of implementation:</b>	
<b>Serial number:</b>	
<b>Customer reference number:</b>	

<b>Location of installment:</b>		<b>Date of product user training:</b>	
---------------------------------	--	---------------------------------------	--

### Scope

The end user (nurse, anesthetist nurse CRNA, medical doctor, surgeon etc. or other personnel who is involved using the product) must be trained according these instructions by the person authorized or in charge of the end user's organization before use of the product (IEC 62366). The training scope includes also technical personnel training at the installation stage (page 2/2).

### Content of end user training

- The overview of the supplied system
- Intended use
- Complete adherence of the user manual
- Cleaning and disinfecting procedures
- Daily maintenance intervals
- Patient and personnel safety factors
- Emergency use and call of service in case of malfunction
- Rights and liabilities, and who is in charge of actions and corrective actions, maintenance, cleaning, inspections
- Warranty terms and conditions
- At the end of the training the participants take part in the test in order to verify their understanding.

### Documentation

- Responsibility for registration of the participants and maintaining records in the register lies on the end user's organization.

### Duration

- The training should last approx. 1 hour; it is recommended to renew at least once every 3 years.

### **Content of technical personnel training**

- Inspect all components supplied
- Installation procedure and implementation according to the installation and maintenance manual
- Patient and personnel safety factors
- Start-up of the system, power supply mains switch and switching On-Off the luminaires
- All central axis adjustments and procedures to change the system settings
- Image transfer from the camera module (if existing)
- Cleaning at stage of implementation and after service
- System maintenance program – Inspection form, maintenance intervals
- Troubleshooting
- System maintenance in practice, required tools etc.
- Replacing the damaged part of the system in place
- Support services, contact information and subscription content, list of spare parts available
- At the end of the training the participants take part in the test in order to verify their understanding.

### **Documentation and maintenance of service history**

- Responsibility for registration of the participants and maintaining records in the register lies on the end user's organization.

### **Duration**

- The training should last approx. 2 hours; it is recommended to renew at least once every 3 years.



**WARNING!** Disregarding these measures will void the warranty and may jeopardize the safety matters concerned which cannot be otherwise guaranteed.

**I assure that the mentioned training measures are completed in accordance with the requirements given:**

**Count of participants**

**Date**

**Signature/Stamp**

**Name of trainer**



PDM Nr:	T403301	Rev Nr:	5	Date:	28Dec17
Written by:	Esko Hyvärinen			Accepted by:	Taymoor Marar

### APPROVAL OF FIXED INSTALLATION AND SYSTEM TESTING

Merivaara Project Identification No:

End-Customer name:

**Description of the Delivered products and if any, reference to the Agreement:**

**Documents provided with the approval letter if applicable:**

- Scope of Work
- Site Preparation Drawings
- Signoff form for ceiling flange installation
- Installation Checklist
- User Manual
- Training record
- 
- 
- 

**Punch list for incomplete items:**

No.	Description	Date to complete
1		
2		
3		
4		
5		
6		
7		
8		



PDM Nr:	T403301	Rev Nr:	5	Date:	28Dec17
Written by:	Esko Hyvärinen			Accepted by:	Taymoor Marar

The agreed items have been delivered, installed and the agreed users trained according to the procedures approved by the End-Customer. Subsequently, the warranty period starts from the effective date (i.e. this letter signed by the End-Customer) of this Approval Letter.

I agree to be listed as a reference site and can be contacted to organize site visits if needed.

\_\_\_\_\_ place: \_\_\_\_\_ date: \_\_\_\_\_

name and title  
Merivaara Corp. / authorized OpenOR distributor

\_\_\_\_\_ place: \_\_\_\_\_ date: \_\_\_\_\_

name and title  
End-Customer Legal Entity

# Annual maintenance inspection form - Q-Flow™ luminaires

Annex 2.

<b>Product/system:</b>	
<b>Date of installation:</b>	
<b>Serial number:</b>	
<b>Customer reference number:</b>	

<b>Location of installment:</b>		<b>Date of product implementation:</b>	
---------------------------------	--	--	--

## Instructions

In this form is presented the annual inspection measures to be completed to the Merivaara Q-Flow™ luminaires.



In order to guarantee a safe use of the Q-Flow™ lighting system, perform the necessary actions and possible follow-ups before check out the box. The defective or incorrectly installed device must not be used! Note! column is to clarify the details related to the measure in words.

## Important information

- This inspection form is only valid when combined with the Installation and maintenance manual and user instructions of the user manual which must be consulted as complementary reference documents during the inspections.
- After 10 years of operation (end of the product service life), these annual maintenance measures must be continued as guided. Perform a complete inspection to the system and its parts that they work as intended.
- If one of the measures is found to be incompliant during the inspection, the luminaire and the system must be placed out of operation immediately as a precaution in order to prevent further damage to persons and equipment.
- Damaged, deformed or missing components must be replaced, contact Merivaara After Sales.

## Documentation

- Responsibility for these measures and maintaining records in the register lies on the end user's organization.
- Copy the blank form of this template annually, fill it in and archive the filled form in a safe place. It is also recommended to keep the information available when ordering spare parts.

	Checked and passed!		Note!
	Ok	No	
<b>Visual inspection</b>			
The parts of the luminaire are not deformed and are free from damage (scratches, cracks, etc.)	<input type="checkbox"/>	<input type="checkbox"/>	
The luminaire(s) surfaces are free from defects in paintwork	<input type="checkbox"/>	<input type="checkbox"/>	
Protective covers are in place properly	<input type="checkbox"/>	<input type="checkbox"/>	
There are no missing parts or any parts have not come loose	<input type="checkbox"/>	<input type="checkbox"/>	
Identity plate and product labels are in place and readable	<input type="checkbox"/>	<input type="checkbox"/>	
All LED modules are fully functional and the light does not flicker	<input type="checkbox"/>	<input type="checkbox"/>	
Covering front glasses is optically clear and free from disruptive scratches	<input type="checkbox"/>	<input type="checkbox"/>	
Check the integrity of the covering front glasses	<input type="checkbox"/>	<input type="checkbox"/>	
The luminaire housing surface coating is completely free from visible flaking.	<input type="checkbox"/>	<input type="checkbox"/>	
The silicone edge trims are in place correctly and there is no visible flaking.	<input type="checkbox"/>	<input type="checkbox"/>	
The covering front glass is completely transparent without any milkyness in the optical opening.	<input type="checkbox"/>	<input type="checkbox"/>	
There is no visible flaking on the touch screen panel housing or on the seams caused by incorrectly made daily cleaning and disinfection.	<input type="checkbox"/>	<input type="checkbox"/>	
<b>Functional check</b>			
The protective collar and the wedge of the balance arm junction are in place.  <b>WARNING!</b> Risk of system or its parts dropping if the installation is made carelessly.	<input type="checkbox"/>	<input type="checkbox"/>	
 <b>WARNING!</b> Falling parts, nobody is allowed to stand under the ceiling tubes or its substructures during the maintenance.			
 The luminaire remains in adjusted position and rotates smoothly in its full adjustment range.	<input type="checkbox"/>	<input type="checkbox"/>	
<b>Functional check</b>			

All mechanical functions as well as the adjustment features of the sterilizable handle works as intended.	<input type="checkbox"/>	<input type="checkbox"/>	
The touch screen panel and Intueri™ (Q-Flow i-series) functions responds correctly	<input type="checkbox"/>	<input type="checkbox"/>	
The luminaire is configured correctly.	<input type="checkbox"/>	<input type="checkbox"/>	
The synchronised control feature of the Q-Flow™ does not control any other Q-Flow™ luminaire in the same building.	<input type="checkbox"/>	<input type="checkbox"/>	
<b>Electrical inspections</b>			
Protective conductor resistance and continuity checked (IEC/EN 62353)	<input type="checkbox"/>	<input type="checkbox"/>	

**WARNING!** Disregarding these annual inspection check points will void the warranty and may jeopardize the safety matters concerned which cannot be otherwise guaranteed.

<p>I assure that the mentioned inspection measures are completed in accordance with the requirements given:</p> <p>Indicate the number of inspection year in question; <input type="text"/> <input type="text"/> <input type="text"/> <input type="text"/> <input type="text"/> <input type="text"/> <input type="text"/> <input type="text"/> <input type="text"/> <input type="text"/> 1. 2. 3. 4. 5. 6. 7. 8. 9. 10.</p> <p><b>Inspector's signature:</b></p>		
_____	_____	_____
<b>Date</b>	<b>Signature/Stamp</b>	<b>Name</b>

