



**FilterWire EZ™ System**  
*Predictable protection made easy*

**In-Service Presentation**

CAUTION: The law restricts these devices to sale by or on the order of a physician. Indications, contraindications, warnings and instructions for use can be found in the product labelling supplied with each device. Information for the use only in countries with applicable health authority product registrations. Indications, operating specifications and availability may vary by country. Check with local product representation and country specific Information For Use for your country.

This material is not approved for use or distribution in France

# IMPORTANT INFORMATION

These materials are intended to describe common clinical considerations and procedural steps for the on-label use of referenced technologies as well as current standards of care for certain conditions.

Of course, patients and their medical circumstances vary, so the clinical considerations and procedural steps described may not be appropriate for every patient or case.

As always, decisions surrounding patient care depend on the physician's professional judgment in light of all available information for the case at hand.

BSC does not promote or encourage the use of its devices outside their approved labeling.

*Indications, contraindications, warnings and instructions for use can be found in the product labeling supplied with each device. Information for the use only in countries with applicable health authority product registrations.*

*This material is not intended for use or distribution in France.*

# FilterWire EZ™ System

With its advanced technology designed for simplicity and effectiveness, the FilterWire EZ Embolic protection System delivers efficient, predictable protection – making it the ideal system for saphenous vein graft (SVG) and carotid artery stenting

## Presentation Contents:

- System Design
  - FilterWire EZ 5.5mm System
  - Protection Wire
  - EZ Delivery Sheath
  - EZ Retrieval Sheath
  - Accessories (peel-away introducer, guide wire torquer, valve dilator tool)
- Product Specs
- Deployment Technique

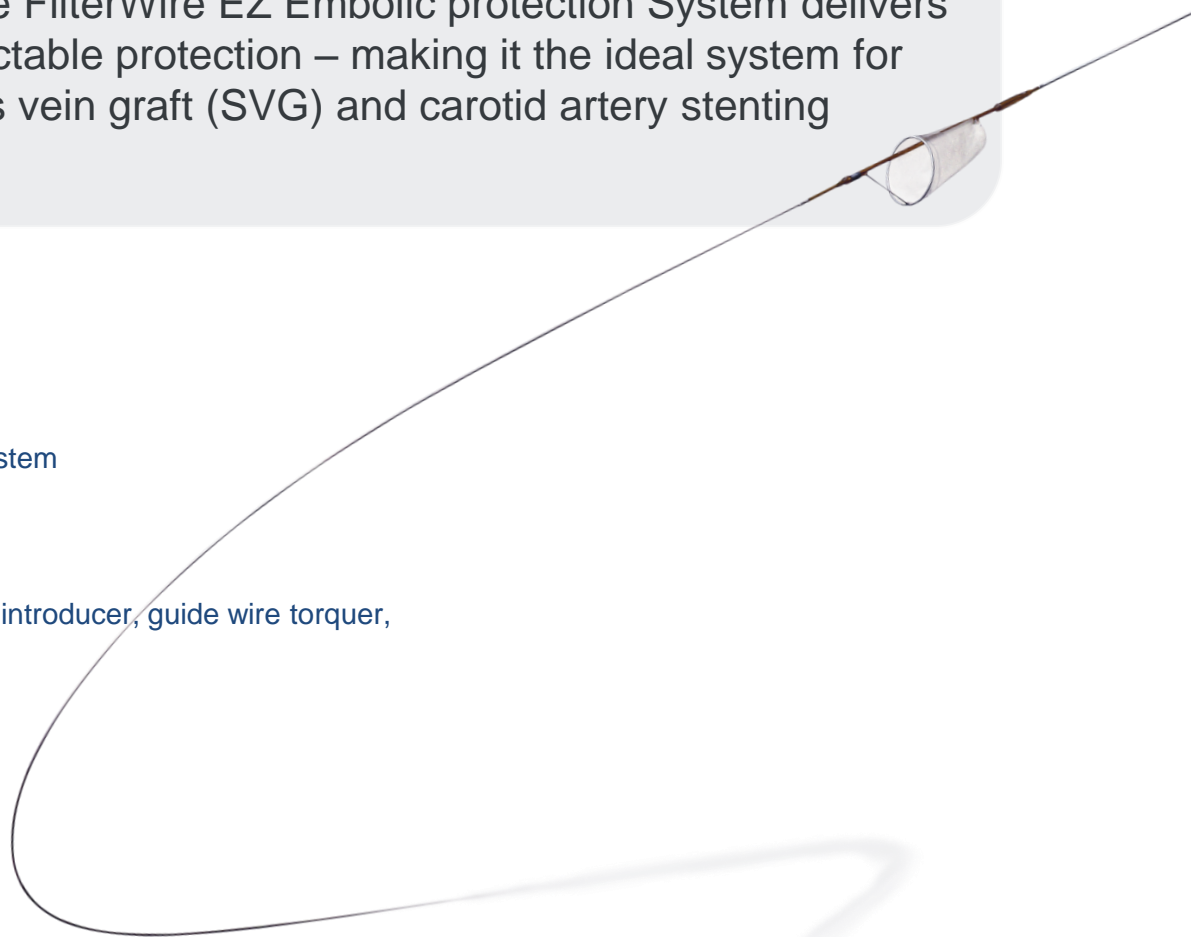

# FilterWire EZ™ System

## *Predictable protection made easy*

### Reliable Wall Apposition

- Suspended filter loop designed to provide 360° degree apposition, reducing particle drift between the filter and the vessel wall\*
- Designed to conform to straight or tortuous anatomy\*
- Radiopaque loop designed to allow for accurate filter placement\*
- One size fits 3.5 mm to 5.5mm vessels

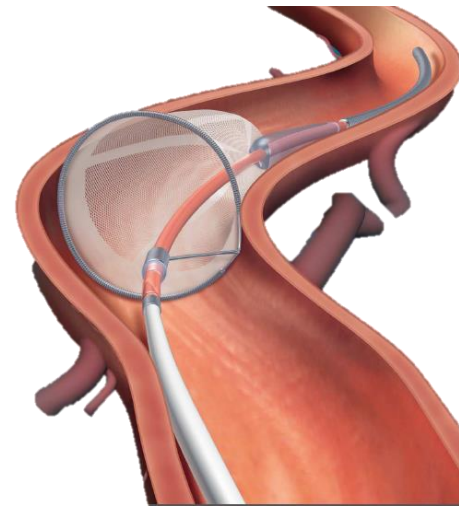

### High Capture Efficiency

- 110 micron pore filter membrane designed to permit continuous blood flow while providing reliable debris capture efficiency\*
- Flexible loop designed to close during retrieval, aims to increase effectiveness of particle retention\*

# FilterWire EZ™ System

## *Predictable protection made easy*

### Deliverability

- Pre-loaded protection wire designed to allow for quick and easy device preparation
- 3.2F crossing profile designed to improve lesion crossing and minimize risk of generating emboli
- Peel-away delivery sheath designed to provide constant wire control with rapid exchange convenience\*
- Easy to use 0.014" Monorail™ Catheter Exchange System

### Retrievability

- Complete sheath coverage of filter during retrieval aimed to reduce risk of stent entanglement\*
- Flexible loop closes during retrieval aimed to increase effectiveness of particle retention

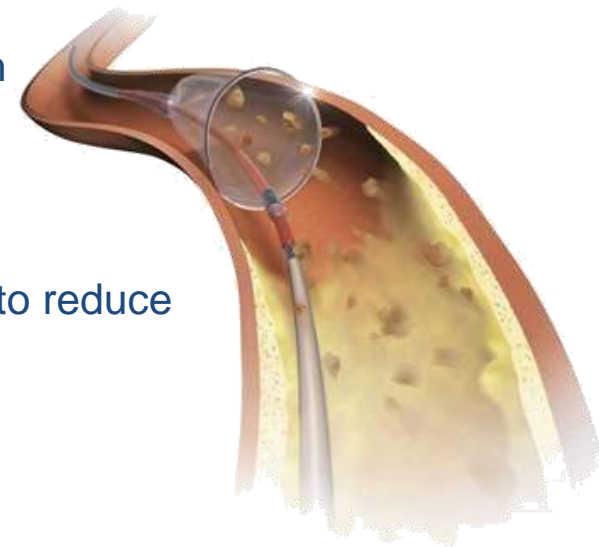



**FilterWire EZ™ System**  
*Predictable protection made easy*

**System Design**

- FilterWire EZ System
- Protection Wire
- EZ Delivery Sheath
- EZ Retrieval Sheath
- Accessories

# FilterWire EZ™ System

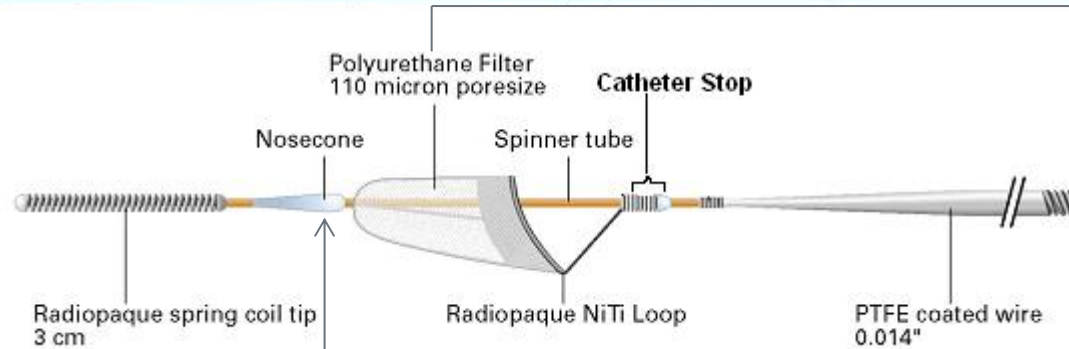

## Atraumatic 3 cm, platinum, spring coil tip with floppy flexibility

- Radiopaque to enhance visualization
- Shapeable to enhance steerability

## 6.0 mm PEBAX® Nosecone

- Flexible transition from the spring tip to the delivery sheath for excellent overall deliverability
- Provides a profile transition that is designed to reduce the risk of debris embolization during system delivery

## Polyurethane filter membrane with 110 micron pores

- Designed to capture debris and reduce the risk of embolic related events
- Intended to permit continuous blood flow for patient safety and comfort
- Intended to permit continuous blood flow that allows contrast injections for visualization during the intervention

# FilterWire EZ™ System

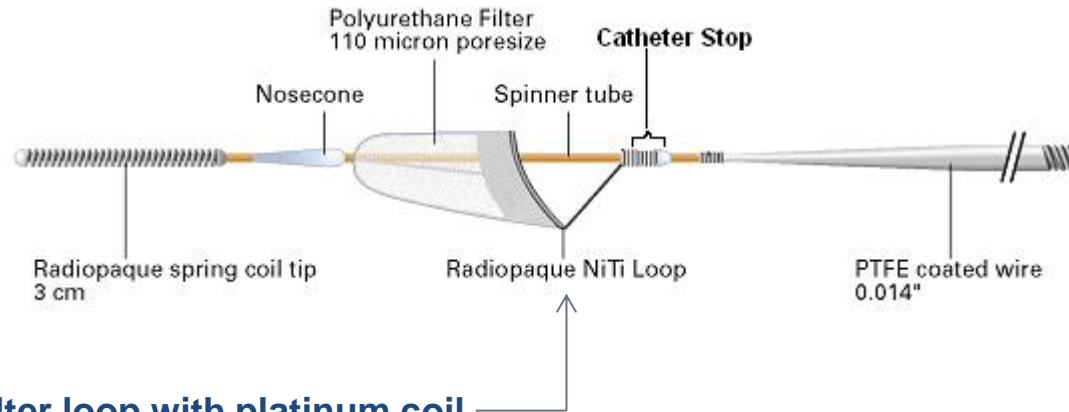

## Conforming, nitinol filter loop with platinum coil

- *Highly visible to guide filter placement and to ensure good vessel wall apposition*
- *One device that accommodates vessels with landing zone diameters ranging from 3.5mm to 5.5mm minimizes sizing guesswork and inventory needs*
- *Designed to provide continuous wall apposition around the circumference of the vessel lumen to minimize the opportunity for debris to collect on the outside of the filter*
- *Automatically adjusts to changes in the vessel aperture*

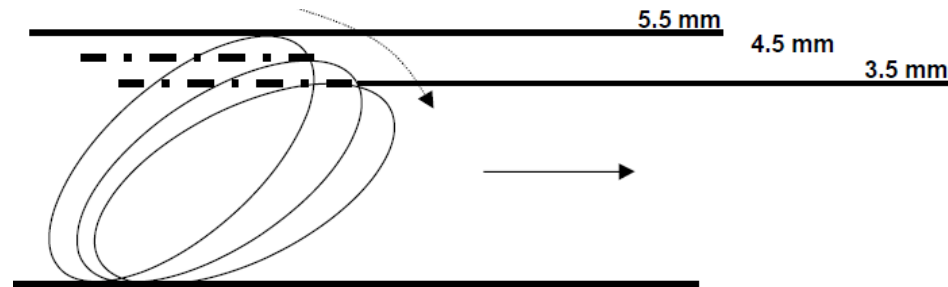



# FilterWire EZ™ System

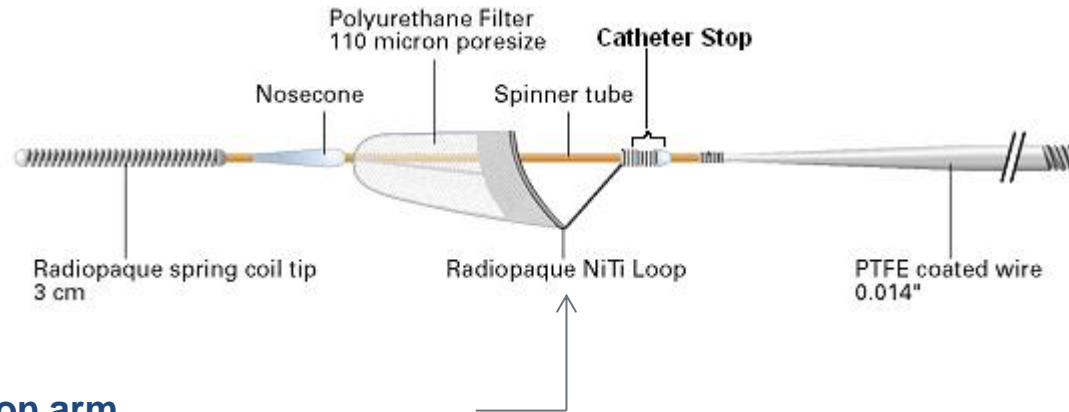

## Filter loop suspension arm

- *Allows the filter loop to move independently from the wire for good vessel wall apposition in both straight and curved anatomy*
- *Simplifies the landing zone requirements by allowing use in both straight and curved vessels*
- *No need to take 2 angio views to assess filter apposition*

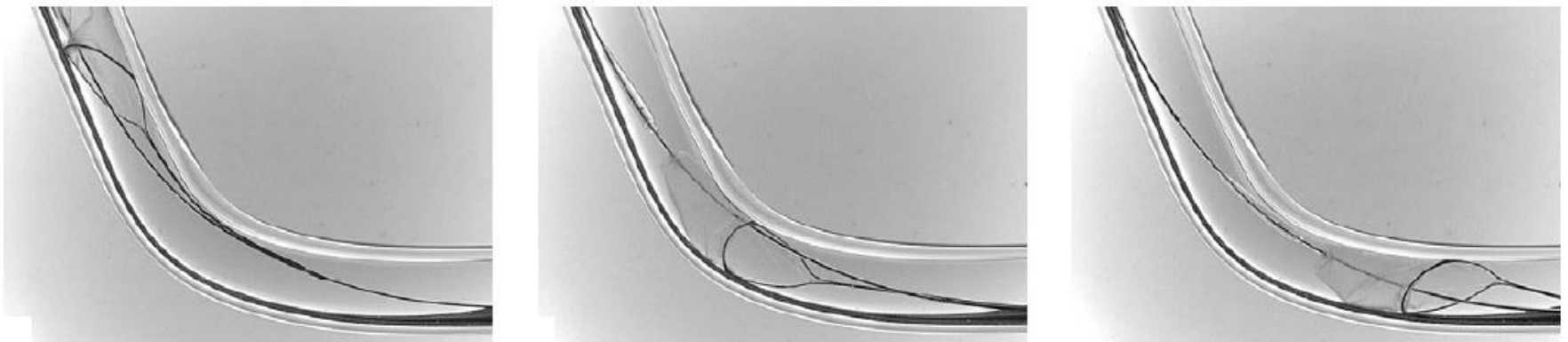

# FilterWire EZ™ System

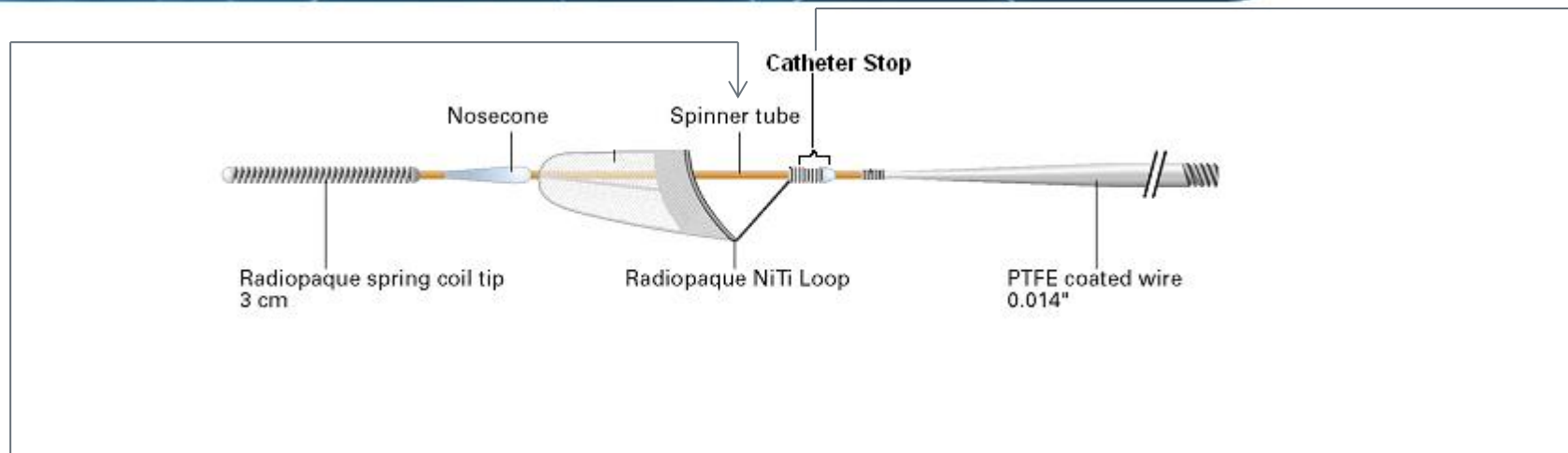

## Spinner tube underlying filter assembly

- Allows the wire to rotate independently from the delivery sheath for excellent system steerability

## .032" OD Catheter stop

- Provides a barrier designed to prevent therapeutic devices from collapsing the filter frame
- Lightly visible to contribute to visualization for device positioning\*

**Note:** A 0.013" OD part 5mm proximal to the catheter stop may also be visible with some equipment. This part keeps the spinner tube in place, but lets catheter tips pass over.

# FilterWire EZ™ System

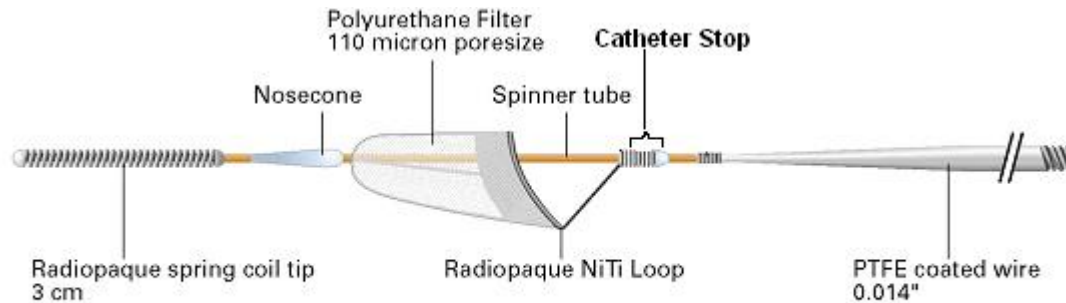

- **0.014" Stainless steel wire body with PTFE coating**

- Available in 190cm and 300cm wire lengths

- 190cm wire length is compatible with BSC's AddWire® GuideWire

- **Silicone coated on distal 15 cm of device, delivery, and retrieval sheath.**

- Designed to reduce the amount of force required to load the filter into the delivery sheath and deploy in the vessel

# EZ Delivery Sheath

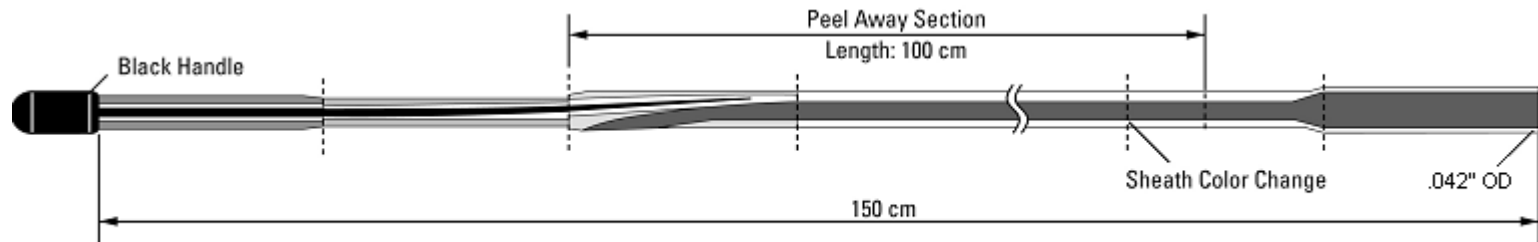

- **150 cm PEBA<sup>®</sup> Resin sheath with 100cm, peel-away exchange length**
  - *The distal sheath changes color from blue to clear to serve as a warning that the non peel-away section at the end of the sheath is approaching*
- **1.1mm (0.042" or 3.2F) Lesion crossing profile**
- **Distal end has a PTFE inner liner**
  - *Internal stop loading feature*
  - *alerts the operator that the filter is fully sheathed*

# EZ Retrieval Sheath

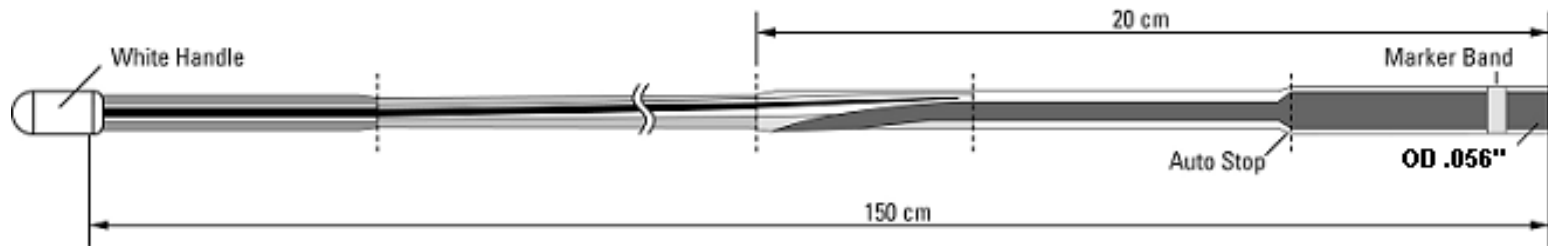

- **150cm PEBAX® Resin sheath with a 20cm long exchange length**
- **Soft distal tip**
  - *Designed to facilitate the capability to cross deployed stents*
- **1.4mm (0.056" or 4.3F) lesion crossing profile**
- **Internal stop capture feature**
  - *Alerts the operator that the filter is fully captured*

# EZ Bent Tip Retrieval Sheath (sold separately)

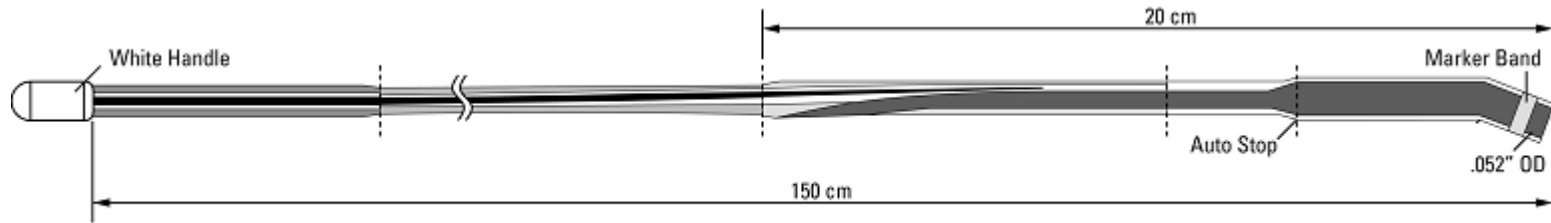

- **150cm PEBAX® Resin sheath with a 20cm exchange length**
- **Bend at distal tip**
  - *The bend is designed to aid in crossing stent struts that can complicate filter retrieval*
- **1.3mm (0.052" or 4.0F) lesion crossing profile**
- **Internal stop capture feature**
  - *Alerts the operator that the filter is fully captured*

## Peel-away Introducer Sheath

- Used to prevent damage to the spring tip of the protection wire during system insertion into a rotating or fixed hemostasis valve.



## Guide Wire Torquer

- Intended to enhance the operator's grip on the protection wire for steerability during delivery and to provide leverage during filter deployment and capture.

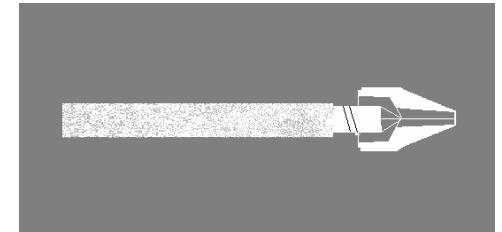

## Valve Dilator Tool

- Used with a fixed hemostasis valve to minimize damage to the filter bag upon removal through the valve.

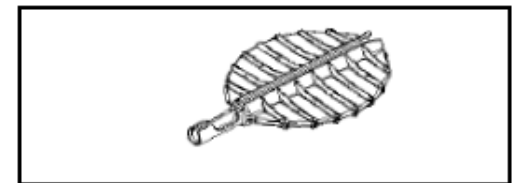



**FilterWire EZ™ System**  
*Predictable protection made easy*

**Product Specs**



# Product Specs

Order Number	Description	Crossing Profile F / inches / mm	Retrieval Profile F / inches / mm	Vessel Compatibility (mm)
H74920105 1900	FilterWire EZ™ 190 cm	3.2 / 0.042 / 1.07	4.3 / 0.056 / 1.42	3.5 - 5.5 mm
H74920105 3000	FilterWire EZ™ 300 cm	3.2 / 0.042 / 1.07	4.3 / 0.056 / 1.42	3.5 - 5.5 mm
H74950100 1500	Bent Tip Retrieval Sheath	4.0 / 0.053 / 1.33	4.0 / 0.053 / 1.33	N / A
H74922150 010	Trooper™ Patriot™ (AddWire™) Extension Wire 0.014" (0.36 mm) 145 cm			



**FilterWire EZ™ System**  
*Predictable protection made easy*

Deployment Technique  
Step-by-step

# IMPORTANT INFORMATION

- Please note that this in-service presentation is intended to supplement to and not a substitute to the detailed information provided in the full product instructions for use.
- Please carefully read all product instructions prior to using this device and observe all warning and precautions noted in those materials as failure to do so may result in complications

# FilterWire EZ™ Embolic Protection System Pre-Procedure

- (1) Review the patient's angiogram and determine if the vessel meets the requirements for safe and effective use of the FilterWire EZ System:
  - a. The apex of the loop can be deployed a minimum of 3.0cm from the distal edge of the lesion.
  - b. The vessel diameter at the desired location of the deployed filter loop is 3.5mm to 5.5mm.
  
- (2) Prior to using the FilterWire EZ System, anticoagulate the patient to achieve an ACT of  $\geq 275$  seconds for carotid applications and  $\geq 300$  seconds for SVG applications ( $>200$  seconds if GP IIb/IIIa inhibitors are used).

*In the absence of ACT measurement, administer an appropriate weight based bolus of heparin (approximately 125 units/kg).*

- (3) Based on vessel take-off, physician should consider which guide catheter shape will provide the best access and support.

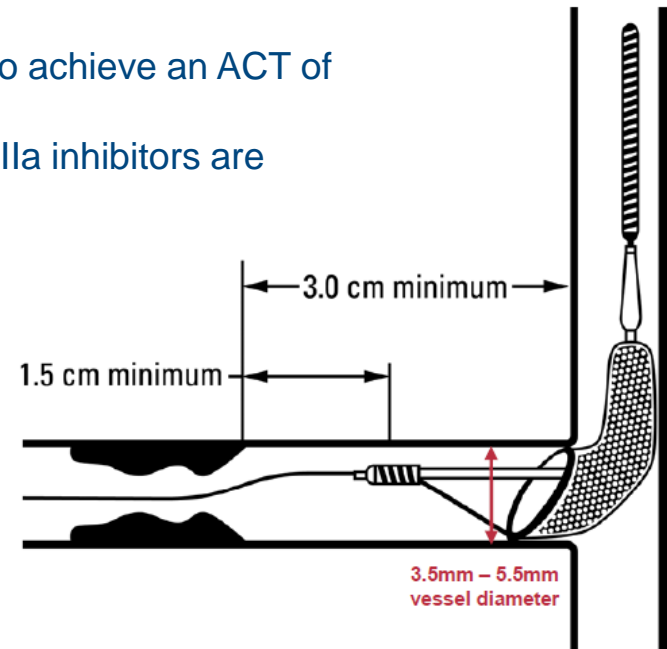

# FilterWire EZ™ Embolic Protection System PREP: Delivery System

1. Open the pouch using sterile handling procedure and place the packaging coils and accessory kit into the sterile field.

2. Unclip and remove the yellow housing that protects the filter.  
*NOTE: The protection wire is pre-loaded into the delivery sheath.*

3. Detach the pre-loaded protection wire from the retaining clip, advance the delivery sheath, then grasp the clear section of the sheath and remove sheathed wire from the coil.

4. Attach the wire torquer onto the proximal end of the protection wire

5. Sheath the protection wire and filter by retracting the device into the EZ Delivery Sheath while the filter is immersed in heparinized saline.  
*NOTE: Hold the Delivery sheath about 1cm proximal to the dark section.*

*NOTE: Keep the filter unsheathed until immediately prior to use.*

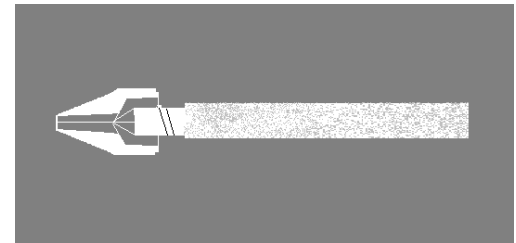

# FilterWire EZ™ Embolic Protection System Delivery

1. Place the peel-away guide wire introducer over the tip of the delivery system (the spring tip of the system can be shaped as needed).

2. Insert the FilterWire EZ System and peel-away introducer assembly into a guide catheter/ sheath. Once the FilterWire EZ System is inserted into the guiding catheter or guiding sheath, remove the peel-away introducer.

**NOTE:** Use of a guiding catheter or a guiding sheath with a 1.91mm (0.075") or larger rotating hemostasis valve is recommended when performing a procedure with the FilterWire EZ System. The use of a sheath /guide catheter with a fixed hemostasis valve may cause the filter membrane to tear at the hemostasis valve upon removal.

3. To advance the FilterWire EZ System through the guiding catheter or guiding sheath, use a one-handed technique advancing both the delivery sheath and protection wire together; this will prevent accidental deployment of the filter.

4. To steer the FilterWire EZ System to the target landing zone, use a two handed technique, torquing the protection wire with one hand and advancing the delivery sheath with the other hand.

**NOTE:** For carotid interventions, having the patient turn their head to the left or right will change the orientation of the vessel and may facilitate device passage.

**NOTE:** Consider using the buddy wire technique if the lesion is difficult to pass. Retract the buddy wire after the lesion has been crossed by the FilterWire EZ System (If other efforts are unsuccessful, pre-dilatation can be used.)

# FilterWire EZ™ Embolic Protection System Delivery

5. Advance the FilterWire EZ System across the lesion until the apex of the filter loop can be deployed a minimum of 3.0cm distal to the lesion.

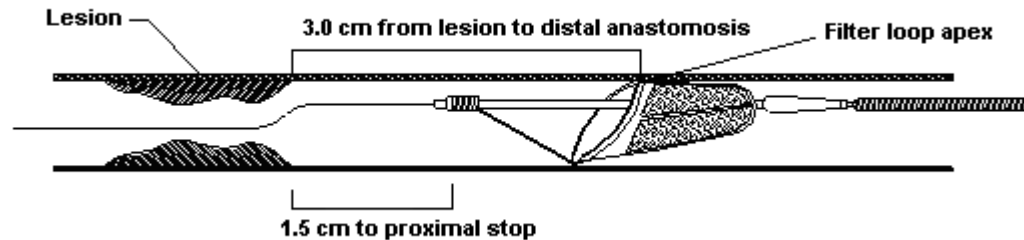

**NOTE:** If an interventional device with a tip-to-shoulder length of greater than 10.0mm is to be used, a longer vessel length may be required to place the FilterWire EZ System in order to avoid contact between the filter's catheter stop and the tip of the interventional device.

# FilterWire EZ™ Embolic Protection System: Filter Deployment

1. Once the protection wire is in place past the lesion, slide the torquer tip up to the hemostatic valve and tighten firmly.
2. Deploy the filter by holding the protection wire with the torquer, then retracting and completely removing the delivery sheath.
3. Be sure to keep the torquer in place as you peel-away the delivery sheath in a straight motion until the 3cm over-the-wire section is reached (see photo below).

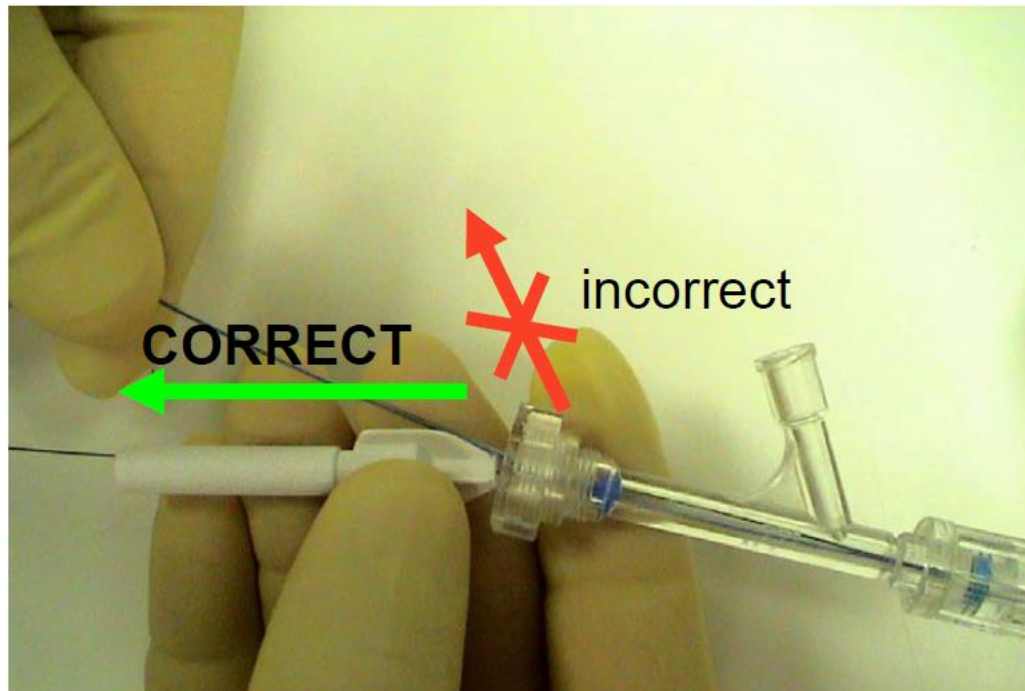



# FilterWire EZ™ Embolic Protection System: Filter Deployment

4. Once the delivery sheath is completely removed, inject contrast and verify the device is in the proper position and there is adequate flow.

*NOTE: If repositioning is required, the EZ Retrieval Sheath should be used. Retract the protection wire and filter loop into the sheath, reposition the filter and redeploy.*

5. Use the protection wire like a traditional guide wire to track catheters and stent delivery systems to the target treatment area.

# FilterWire EZ™ Embolic Protection System: During the Procedure

1. Inject contrast frequently and always after any intervention or exchange, to visually verify that blood flow is not obstructed and that filter loop/vessel apposition to the vessel wall is maintained.

***CAUTION:*** *If a filter becomes occluded during the procedure, remove it and deploy a second filter if further intervention is required.*

2. Complete the procedure making sure the protection wire remains in the proper position distal to the lesion (monitor fluoroscopy).

***Note:*** *Failure to stabilize the protection wire could lead to inadvertent movement of the filter, resulting in protection wire entanglement and/or delay in the procedure.*

# FilterWire EZ™ Embolic Protection System: Filter Capture and Retrieval

1. Remove the EZ Retrieval Sheath from its packaging coil and flush with heparinized saline.
2. Advance the retrieval sheath over the protection wire past any deployed stents up to the proximal end of the filter loop.

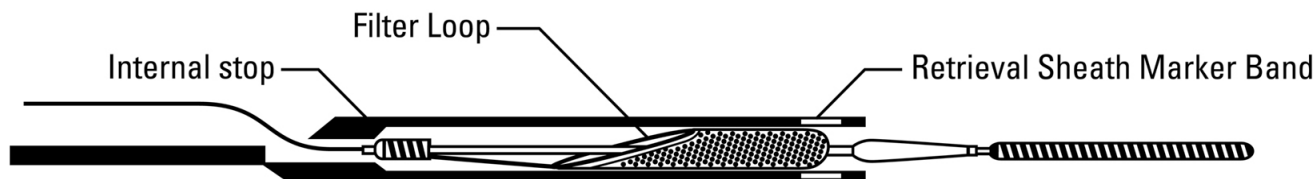

**Note:** If the EZ Retrieval Sheath is not able to pass the deployed stent, be sure the stent is well apposed and consider post-dilatation. If the Retrieval Sheath is still unable to cross, try the EZ Bent Tip Retrieval Sheath (available separately).

# FilterWire EZ™ Embolic Protection System: Filter Capture and Retrieval

3. Gently and slowly retract the protection wire and filter loop back into the retrieval sheath until resistance is felt.

4. Observe the retrieval procedure under fluoroscopic imaging.

**Note:** The distal edge of the collapsed filter loop should align with (see figure B), or be proximal to (figure A), the retrieval sheath marker band.

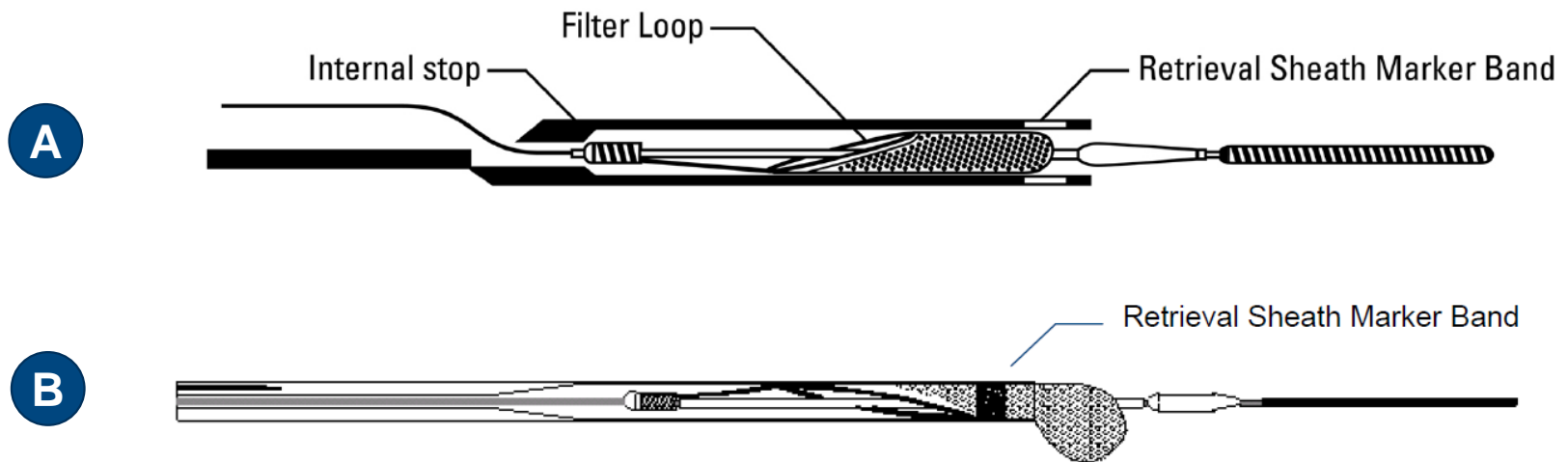

# FilterWire EZ™ Embolic Protection System: Filter Capture and Retrieval

**NOTE:** If resistance is felt before the distal edge of the collapsed filter loop is aligned with the marker band, it is possible that there is a large amount of embolic debris in the filter. Carefully retract the protection wire and EZ Retrieval Sheath as a system. The distal part of the filter bag will be outside of the sheath during retrieval in this case; however, the filter loop must be pulled fully into the sheath.

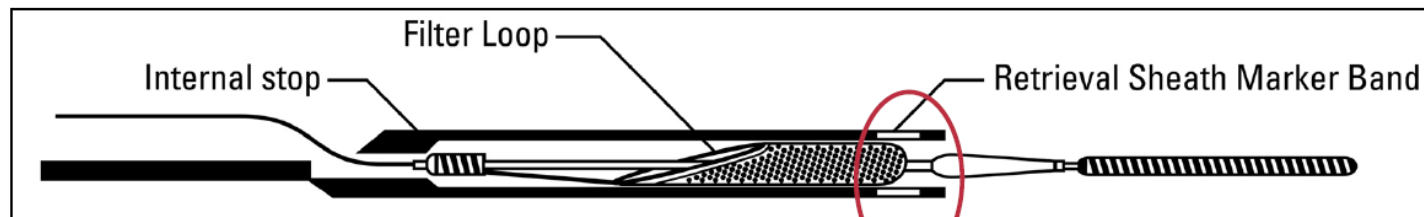

**Fully Retracted Filter**

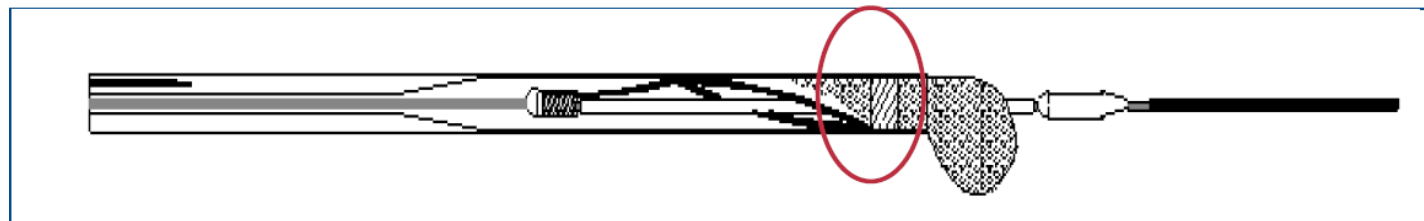

**Large Debris Load in Filter**

# FilterWire EZ™ Embolic Protection System: Filter Capture and Retrieval

5. If any resistance is met during retraction of the sheathed FilterWire EZ System, slightly advance the sheathed FilterWire EZ System and rotate the sheath before continuing to retract.
6. Slowly and carefully retract the entire system until the tip of the retrieval sheath is adjacent to the tip of the guiding catheter or guiding sheath.
7. If there is any resistance, retract the guiding catheter and FilterWire EZ System together. This is done in case there is a large amount of embolic material captured in the filter that may not fit inside the guiding catheter.
8. Remove the FilterWire EZ System from the patient.  
**NOTE:** When using a rotating hemostasis valve, ensure that the hemostasis valve is fully opened prior to FilterWire EZ System removal.  
**CAUTION:** If a guide sheath with a fixed hemostasis valve is used, the valve dilator tool is required for FilterWire EZ System removal. Removing the FilterWire EZ System through a fixed hemostasis valve without the use of a valve dilator may cause the filter membrane to tear.
9. If a fixed hemostasis valve is used, place the valve dilator (if provided in the accessory kit) on the shaft of the retrieval sheath and slide the tool into the valve. Then remove the FilterWire EZ System from the patient through the valve dilator tool and remove the dilator.

*Potential for a distal embolic protection filter to entangle with a stent is inherent to interventional procedures using these devices.*

## **SAFE PRACTICE FOR DISTAL PROTECTION FILTERS**

1. Achieve good guide catheter or guide sheath support
2. Ensure sufficient landing zone
3. Keep the filter in place during deployment
4. Minimize wire movement during the procedure
5. Achieve full stent apposition

# FilterWire EZ™ Embolic Protection System

## Tips for Use

### Key Success Factors for Using the FilterWire EZ System

1. Keep ACT levels  $\geq 275$  seconds for carotid procedures and  $\geq 300$  seconds for SVG procedures.
2. If there is difficulty crossing the lesion, try a buddy wire and/or, for carotid procedures, have the patient turn their head to the left or right.
3. For carotid procedures, place the filter as distal as possible while remaining within the extracranial portion of the ICA.
4. During deployment and exchanges, stabilize the wire and wipe it frequently to decrease friction.
5. Keep your eye on the filter! Know where it is and know where it is supposed to be.
6. Verify flow often. Slow flow? Finish the procedure and remove. No flow? Remove and replace. The FilterWire EZ System needs flow to function.
7. Do not treat the lesion or “touch up” without a FilterWire EZ System in place.