

Prüfbericht-Nr.: <i>Test report no.:</i>	HU26KKKQ 001	Auftrags-Nr.: <i>Order no.:</i>	301570936 P02211707	Seite 1 von 49 Page 1 of 49	
Kunden-Referenz-Nr.: <i>Client Reference No.:</i>	N/A	Auftragsdatum: <i>Order date:</i>	2026-03-02		
Auftraggeber: <i>Client:</i>	AETA SA Bucharest, str. Horatiu 8-10, 010834, Romania				
Prüfgegenstand: <i>Test item:</i>	Fahrbare Abfall- und Werkstoffbehälter mit 2 Rädern Mobile waste and recycling container with 2 wheels				
Bezeichnung / Typ-Nr.: <i>Identification / Type No.:</i>	Wave bin 240 l				
Auftrags-Inhalt: <i>Order content:</i>	Mechanical safety test				
Prüfgrundlage: <i>Test specification:</i>	EN 840-1: 2020 EN 840-5: 2020 EN 840-6: 2020				
Wareneingangsdatum: <i>Date of receipt:</i>	2026-02-26; 2026-05-07				
Prüfmuster-Nr.: <i>Test sample No.:</i>	A004217436-001; A004271416-001-002				
Prüfzeitraum: <i>Testing period:</i>	2026-02-26 – 2026-05-12				
Ort der Prüfung: <i>Place of testing:</i>	TÜV Rheinland InterCert Kft. H-1143 Bp., Gizella u. 51-57.				
Prüflaboratorium: <i>Testing laboratory:</i>	TÜV Rheinland InterCert Kft. H-1143 Bp., Gizella u. 51-57.				
Prüfergebnis*: <i>Test result*:</i>	Pass				
geprüft von: <i>tested by:</i>	 Signed by: Petra Pinter		genehmigt von: <i>authorized by:</i>	 Signed by: Szoke Norbert	
Datum: <i>Date:</i>	2026-05-12		Ausstellungsdatum: <i>Issue date:</i>	2026-05-12	
Stellung / Position:	Sachverständige(r)/Expert		Stellung / Position:	Sachverständige(r)/Expert	
Sonstiges / Other:	Foreseeable misuse has been considered. Currently neither a safeguard clause procedure has been invoked nor is an increase in accidents known for this / these product(s). Hersteller/Manufacturer: AETA SA. Attachment 1 – Photo documentation (6 pages) This test report is based on, and valid only together with test report of HU26MNUK 001 (2021-06-09). Testing laboratory accredited by NAH under No NAH-1-1760/2024/K.				
Zustand des Prüfgegenstandes bei Anlieferung: <i>Condition of the test item at delivery:</i>	Prüfmuster vollständig und unbeschädigt Test item complete and undamaged				
* Legende:	1 = sehr gut P(ass) = entspricht o.g. Prüfgrundlage(n)	2 = gut F(ail) = entspricht nicht o.g. Prüfgrundlage(n)	3 = befriedigend N/A = nicht anwendbar	4 = ausreichend N/T = nicht getestet	5 = mangelhaft N/T = nicht getestet
* Legend:	1 = very good P(ass) = passed a.m. test specification(s)	2 = good F(ail) = failed a.m. test specification(s)	3 = satisfactory N/A = not applicable	4 = sufficient N/T = not tested	5 = poor N/T = not tested
<p>Dieser Prüfbericht bezieht sich nur auf das o.g. Prüfmuster und darf ohne Genehmigung der Prüfstelle nicht auszugsweise vervielfältigt werden. Dieser Bericht berechtigt nicht zur Verwendung eines Prüfzeichens. <i>This test report only relates to the a. m. test sample. Without permission of the test center this test report is not permitted to be duplicated in extracts. This test report does not entitle to carry any test mark.</i></p>					

Prüfbericht-Nr.: HU26KKKQ 001
Test report no.:

Seite 2 von 49
Page 2 of 49

Absatz Clause	Anforderungen - Prüfungen / Requirements - Tests	Messergebnisse – Bemerkungen / Measuring results - Remarks	Ergebnis Result
------------------	---	--	--------------------

1	<p>Alle eingesetzten Prüfmittel waren zum angegebenen Prüfzeitraum gemäß eines festgelegten Kalibrierungsprogramms unseres Prüfhauses kalibriert. Sie entsprechen den in den Prüfprogrammen hinterlegten Anforderungen. Die Rückverfolgbarkeit der eingesetzten Prüfmittel ist durch die Einhaltung der Regelungen unseres Managementsystems gegeben. Detaillierte Informationen bezüglich Prüfbedingungen, Prüfequipment und Messunsicherheiten sind im Prüflabor vorhanden und können auf Wunsch bereitgestellt werden.</p> <p><i>The equipment used during the specified testing period was calibrated according to our test laboratory calibration program. The equipment fulfils the requirements included in the relevant standards. The traceability of the test equipment used is ensured by compliance with the regulations of our management system. Detailed information regarding test conditions, equipment and measurement uncertainty is available in the test laboratory and could be provided on request.</i></p>		
2	<p>Wie vertraglich vereinbart, wurde dieses Dokument nur digital unterzeichnet. Der TÜV Rheinland hat nicht überprüft, welche rechtlichen oder sonstigen diesbezüglichen Anforderungen für dieses Dokument gelten. Diese Überprüfung liegt in der Verantwortung des Benutzers dieses Dokuments. Auf Verlangen des Kunden kann der TÜV Rheinland die Gültigkeit der digitalen Signatur durch ein gesondertes Dokument bestätigen. Diese Anfrage ist an unseren Vertrieb zu richten. Eine Umweltgebühr für einen solchen zusätzlichen Service wird erhoben.</p> <p><i>As contractually agreed, this document has been signed digitally only. TUV Rheinland has not verified and unable to verify which legal or other pertaining requirements are applicable for this document. Such verification is within the responsibility of the user of this document. Upon request by its client, TUV Rheinland can confirm the validity of the digital signature by a separate document. Such request shall be addressed to our Sales department. An environmental fee for such additional service will be charged.</i></p>		
3	<p>Die Entscheidungsregel für Konformitätserklärungen basierend auf numerischen Messergebnissen in diesem Prüfbericht basiert auf der "Null-Grenzwert-Regel" und der "Einfachen Akzeptanz" gemäß ILAC G8:2019 und IEC Guide 115:2021, es sei denn, in der auf Seite 1 dieses Berichts genannten angewandten Norm ist etwas anderes festgelegt oder vom Kunden gewünscht. Dies bedeutet, dass die Messunsicherheit nicht berücksichtigt wird und daher auch nicht im Prüfbericht angegeben wird. Zu weiteren Informationen bezüglich des Risikos durch diese Entscheidungsregel siehe ILAC G8:2019.</p> <p><i>The decision rule for statements of conformity, based on numerical measurement results, in this test report is based on the "Zero Guard Band Rule" and "Simple Acceptance" in accordance with ILAC G8:2019 and IEC Guide 115:2021, unless otherwise specified in the applied standard mentioned on Page 1 of this report or requested by the customer. This means that measurement uncertainty is not taken in account and hence also not declared in the test report. For additional information to the resulting risk based of this decision rule please refer to ILAC G8:2019.</i></p>		
4	<p>The report is issued electronically. It is valid in the digitally signed PDF file. You can find details on the Singature Panel, check the signature named „TUEV-RHEINLAND-DOCUMENTS“. Any printed version of this PDF file is considered as a copy, where the authenticity cannot be</p>		
5			

Produktbeschreibung <i>Product description</i>
--

1	Produktdetails <i>Product details</i>	Mobile waste and recycling container with 2 wheels type: Wave bin 240 l
2	Maße / Gewicht <i>Dimensions / Weight</i>	Dimensions: 578 x 737 x 1023 [mm] (L x W x H) Weight: 12,8 kg
3	Bedienelemente <i>Operating elements</i>	2 rubber wheels (Ø 200 mm), steel axle, plastic body, plastic lid, 2 x plastic lid fixing pins
4	Verwendete Materialien <i>Used materials</i>	HDPE (lid, body) , Rubber wheels, steel axle, plastic fixing pins
5	Sonstiges <i>Other</i>	Test sample(s), as well sample information, description, product details and intended usage was provided by customer.
6	Prüfmusterbereitstellung: <i>Test sample obtaining:</i>	<input checked="" type="checkbox"/> Sending by customer <input type="checkbox"/> Sampling by TÜV Rheinland Group <input type="checkbox"/> others:

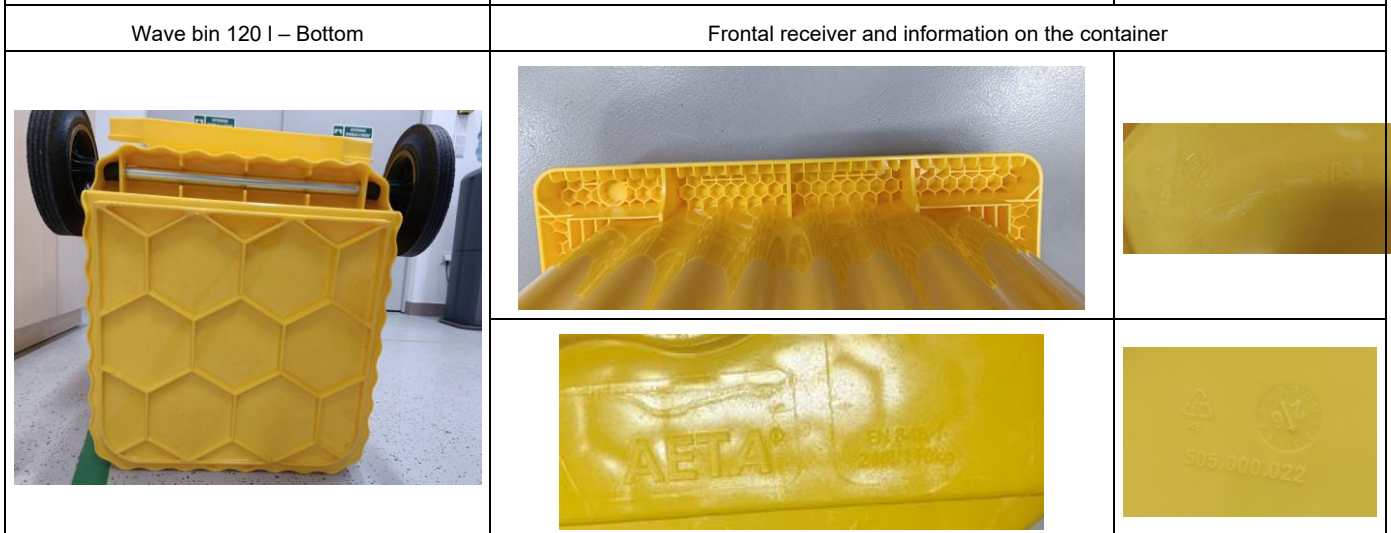
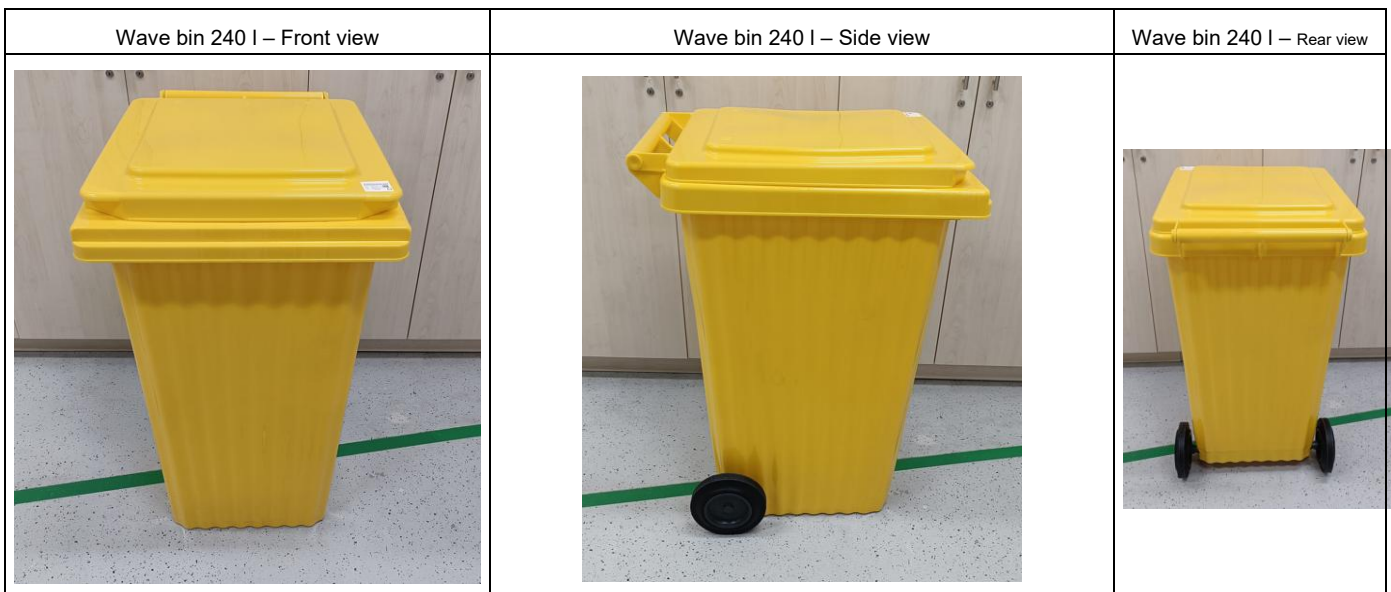

Prüfbericht-Nr.: HU26KKKQ 001
Test Report No.:

Absatz	EN 840-1: 2020	Messergebnisse - Bemerkungen	Bewertung
Clause	Anforderungen - Prüfungen / Requirements - Tests	Measuring results - Remarks	Evaluation

1	Scope		
	This European Standard specifies dimensions and design requirements of mobile waste and recycling containers with 2 wheels, with capacity up to 400 l to be used by comb lifting devices.		
2	Normative references		
	See DIN EN 840-1:2020		
3	Terms and definitions		
	See DIN EN 840-1:2020		
4	Volumes		
	<p>This standard identifies the two classes of containers:</p> <ul style="list-style-type: none"> - Class I - small size (nominal volume up to 200 l); - Class II - large size (nominal volume between 200 l and 400 l). <p>Within the two above-mentioned classes of containers the volumes shown in Table 1 are identified.</p> <p>For methods of measuring capacity, see EN 840-5.</p> <p>The volumes shown in Table 1 correspond to mobile waste and recycling container's capacities at present used in Europe. Since there are some overlapping capacities due to the tolerances, client and manufacturer shall decide while ordering the capacity chosen.</p> <p>Nominal volumes different from those referenced in Table 1 can be used by agreement between user and manufacturer. The tolerance of the volumes shall be $\pm 10\%$ maximum measured according to EN 840-5. Table 2 includes examples of the most frequent assignments of classes and volumes of the containers.</p>	<p>Class II b – 240 liter</p> <ul style="list-style-type: none"> • Wave bin 240 l 	<p>P <input checked="" type="checkbox"/></p> <p>F <input type="checkbox"/></p> <p>N/A <input type="checkbox"/></p> <p>N/T <input type="checkbox"/></p>

Prüfbericht-Nr.: HU26KKKQ 001
Test Report No.:

Seite 5 von 49
Page 5 of 49

Absatz	EN 840-1: 2020	Messergebnisse - Bemerkungen	Bewertung
Clause	Anforderungen - Prüfungen / Requirements - Tests	Measuring results - Remarks	Evaluation

Table 1 — Volumes

Volume in l										
60^{+13}_{-5}	80^{+18}_{-5}	120^{+8}_{-6}	140^{+6}_{-12}	180^{+40}_{-10}	190^{+25}_{-10}	210^{+15}_{-5}	240^{+15}_{-5}	260^{+25}_{-5}	340^{+10}_{-25}	390 ± 20

Table 2 — Examples of the most frequent assignments of classes and volumes

Class I a	Class I b	Class I c	Class I d	Class II a	Class II b	Class II c	Class II d
e.g. 60 l	e.g. 120 l	e.g. 140 l	e.g. 180 l	e.g. 210 l	e.g. 240 l	e.g. 340 l	e.g. 390 l
80 l	110 l		190 l	190 l		260 l	370 l
90 l				180 l		360 l	400 l

5 Dimensions and design

5.1	The design of the containers need not correspond to the drawings given in Figure 1. The functional dimensions given in Tables 3 and 4 shall be respected. For compatibility in lifting devices, the container shall correspond to its dimensions within the selected class type (Table 3, Table 4).	Dimensions correspond to Figure 1 (For dimensions, see at page 49)	P <input checked="" type="checkbox"/> F <input type="checkbox"/> N/A <input type="checkbox"/> N/T <input type="checkbox"/>
5.2	The container shall be constructed so that when it is unloaded or loaded with a nominal load (see Clause 6), it fits on an approved compatible lifting device. It shall be automatically locked safely into the lifting device during the lifting operation. The frontal receiver shall correspond to one of the options given in Figure 2 (Form A or B).	Frontal receivers corresponds to Figure 2 (For dimensions, see at page 49)	P <input checked="" type="checkbox"/> F <input type="checkbox"/> N/A <input type="checkbox"/> N/T <input type="checkbox"/>

Prüfbericht-Nr.: HU26KKKQ 001 Test Report No.:			
Absatz	EN 840-1: 2020	Messergebnisse - Bemerkungen	Bewertung
Clause	Anforderungen - Prüfungen / Requirements - Tests	Measuring results - Remarks	Evaluation
5.3	The lid(s) shall cover the opening of the container completely. It shall be opened easily by itself during the emptying cycle. It/they shall be made with at least 2 fixing points and have at least one means of opening.	Lid is easy to use, easily move. One opening, the lid has 2 fixing points with the body	P <input checked="" type="checkbox"/> F <input type="checkbox"/> N/A <input type="checkbox"/> N/T <input type="checkbox"/>
5.4	Each wheel shall be capable of withstanding a static load of 100 kg.	Certificates were provided for ⊙200mm wheels. SKZ certificate: SKZ 59314 (2014-03-12) Manufacturer: TW Reifen- und Räderhandels-gesellschaft mbH Artikel-Nr.: 4036.004 Test report: 116245/15 (2015-05-27)	P <input checked="" type="checkbox"/> F <input type="checkbox"/> N/A <input type="checkbox"/> N/T <input type="checkbox"/>
5.5	All the surfaces of the container including design features shall be smooth and free of any foreign bodies or flaws.	The samples are free from any foreign bodies, and burrs.	P <input checked="" type="checkbox"/> F <input type="checkbox"/> N/A <input type="checkbox"/> N/T <input type="checkbox"/>

Prüfbericht-Nr.: HU26KKKQ 001 Test Report No.:			
Absatz Clause	EN 840-1: 2020 Anforderungen - Prüfungen / Requirements - Tests	Messergebnisse - Bemerkungen Measuring results - Remarks	Bewertung Evaluation
5.6	The container shall be able to be immobilised by design.	For information	P <input checked="" type="checkbox"/> F <input type="checkbox"/> N/A <input type="checkbox"/> N/T <input type="checkbox"/>
6	Nominal mass		
	The container shall be constructed strongly enough to carry a mass of 0,4 kg/dm ³ x nominal volume.	240 l – 96 kg Tests acc. to EN 840-5:2020 and EN 840-6:2020 finished with pass result, which indicate that the containers are strong enough to carry the nominal load.	P <input checked="" type="checkbox"/> F <input type="checkbox"/> N/A <input type="checkbox"/> N/T <input type="checkbox"/>
7	Safety and health requirements		
	The container shall meet the safety and health requirements according to EN 840-6.	See from page 38 to page 48	P <input checked="" type="checkbox"/> F <input type="checkbox"/> N/A <input type="checkbox"/> N/T <input type="checkbox"/>
8	Testing		
	The container shall fulfil the performance requirements and the tests of EN 840-5.	See from page 17 to page 37	P <input checked="" type="checkbox"/> F <input type="checkbox"/> N/A <input type="checkbox"/> N/T <input type="checkbox"/>

Prüfbericht-Nr.: HU26KKKQ 001
Test Report No.:

Absatz	EN 840-1: 2020	Messergebnisse - Bemerkungen	Bewertung
Clause	Anforderungen - Prüfungen / Requirements - Tests	Measuring results - Remarks	Evaluation

9	Marking		
9.1	<p>Each container complying with the requirements of this European Standard shall be durably and readably marked on the body in a visible part with:</p> <ul style="list-style-type: none"> - number of this European Standard (EN 840-1); - nominal volume; - manufacturer's name or trademark; - total permissible mass, in kilograms; - year and month of manufacturing. 	<p>All the necessary information are on the surface of the container.</p> <p>(see at page 3)</p>	P <input checked="" type="checkbox"/> F <input type="checkbox"/> N/A <input type="checkbox"/> N/T <input type="checkbox"/>
9.2	<p>Plastic parts of containers, lids and wheels shall be marked in accordance with EN ISO 11496. The use of recycled materials is allowed, presuming that all requirements of the standard are complied with.</p>	<p>suitable marking ASTM International Resin Identification Coding System symbols are used.</p> <p>(see on page 3)</p>	P <input checked="" type="checkbox"/> F <input type="checkbox"/> N/A <input type="checkbox"/> N/T <input type="checkbox"/>

Prüfbericht-Nr.: HU26KKKQ 001
Test Report No.:

Absatz	EN 840-1: 2020	Messergebnisse - Bemerkungen	Bewertung
Clause	Anforderungen - Prüfungen / Requirements - Tests	Measuring results - Remarks	Evaluation

10	Designation																																						
	The container complying with the requirements of this European Standard shall be designated as follows:	Wave bin 240 I Type A EN 840-1 240 A 96	P <input checked="" type="checkbox"/> F <input type="checkbox"/> N/A <input type="checkbox"/> N/T <input type="checkbox"/>																																				
	<table border="1"> <thead> <tr> <th></th> <th>Container</th> <th>EN 840-1</th> <th>240</th> <th>A</th> <th>96</th> </tr> </thead> <tbody> <tr> <td>Description</td> <td colspan="5">_____</td> </tr> <tr> <td>Standard number</td> <td colspan="5">_____</td> </tr> <tr> <td>Nominal volume, in litres</td> <td colspan="5">_____</td> </tr> <tr> <td>Frontal receiver form: A = frontal receiver form A B = frontal receiver form B</td> <td colspan="5">_____</td> </tr> <tr> <td>Nominal load, in kilograms</td> <td colspan="5">_____</td> </tr> </tbody> </table>				Container	EN 840-1	240	A	96	Description	_____					Standard number	_____					Nominal volume, in litres	_____					Frontal receiver form: A = frontal receiver form A B = frontal receiver form B	_____					Nominal load, in kilograms	_____				
	Container	EN 840-1	240	A	96																																		
Description	_____																																						
Standard number	_____																																						
Nominal volume, in litres	_____																																						
Frontal receiver form: A = frontal receiver form A B = frontal receiver form B	_____																																						
Nominal load, in kilograms	_____																																						

Prüfbericht-Nr.: HU26KKKQ 001
Test Report No.:

Seite 10 von 49
Page 10 of 49

Absatz	EN 840-1: 2020	Messergebnisse - Bemerkungen	Bewertung
Clause	Anforderungen - Prüfungen / Requirements - Tests	Measuring results - Remarks	Evaluation

Table 3 — Dimensions for containers - Class I (up to 200 l)

Dimensions in millimetres

Dimen- sion N°	Class I a		Class I b	Class I c	Class I d	Remarks
	Type a	Type b				
1a	448 ± 5	480 ± 5	505 max.	505 max.	505 max.	Total width of the container
2a	448 ± 5	480 ± 5	480 ± 5	480 ± 5	480 ± 5	Width of the frontal receiver
3	530 max.	555 max.	555 max.	555 max.	755 max.	
4	1 005 max		1005 max.	1 100 max.	1 100 max.	Total height including handles on the lid
5a	860 min.; 970 max.		860 min.; 970 max.	860 min.; 1030 max.	860 min.; 1030 max.	
6	450 max.	490 max.	490 max.	490 max.	500 max.	
7	1 010 max.		1010 max.	1 155 max.	1 200 max.	
8	430 min.; 670 max.		430 min.; 670 max.	430 min.; 670 max.	560 min; 760 max	For 300 mm wheels, the maximum dimension is 70 mm more.
10	320 ± 10	385 max	385 max.	385 max.	410 max.	
11a	200 ⁺¹ _{-.5}		200 ⁺¹ _{-.5}	200 ⁺¹ _{-.5}	200 ⁺¹ _{-.5}	Larger wheels accepted
12a	19 min.		19 min.	19 min.	19 min.	
13a	6 ⁺² _{-.4,5}		6 ⁺² _{-.4,5}	6 ⁺² _{-.4,5}	6 ⁺² _{-.4,5}	
15a	13 ⁺⁵ _{-.3}		13 ⁺⁵ _{-.3}	13 ⁺⁵ _{-.3}	13 ⁺⁵ _{-.3}	
16a	21 ⁺² _{-.2}		21 ⁺² _{-.2}	21 ⁺² _{-.2}	21 ⁺² _{-.2}	
18a	26 ± 1		26 ± 1	26 ± 1	26 ± 1	
19a	58 max.		58 max.	58 max.	58 max.	
20	20 min.		20 min.	20 min.	20 min.	
21a	130 max.		130 max.	130 max.	130 max.	
22	15 max.		15 max.	15 max.	15 max.	
23	33 ⁺⁸ ₀		33 ⁺⁸ ₀	33 ⁺⁸ ₀	33 ⁺⁸ ₀	

Text Kursiv

Prüfbericht-Nr.: HU26KKKQ 001
Test Report No.:

Seite 11 von 49
Page 11 of 49

Absatz	EN 840-1: 2020	Messergebnisse - Bemerkungen	Bewertung
Clause	Anforderungen - Prüfungen / Requirements - Tests	Measuring results - Remarks	Evaluation

Dimen- sion N°	Class I a		Class I b	Class I c	Class I d	Remarks
	Type a	Type b				
26 ^a	147 ± 8	180 ± 5	180 ± 5	180 ± 5	180 ± 5	Compulsory dimensions when ribs are fitted, max. ribs thickness 6 mm A middle rib is only allowed with class II a type a, class II b, class II c, class II d type b.
27	270° min.		270° min.	270° min.	270° min.	
28	413 min	445 min	445 min. ^b	445 min. ^b	445 min.	The dimension No 28 has to correspond to Figure 3 and the lifting device. Definition in accordance with comb dimension, standard and identification character of EN 1501-5:—
<p>^a Compulsory dimensions for functional and safety reasons. The other dimensions indicated are suggested recommended values.</p> <p>^b This dimension in Class I b and Class I c is to be maintained as minimum for new designed containers. For earlier containers applies up to 420 min.</p> <p>NOTE Dimensions 9, 14, 17, 24 and 25 are no longer used and have been deleted from the table as a result.</p>						

Prüfbericht-Nr.: HU26KKKQ 001
Test Report No.:

Seite 12 von 49
Page 12 of 49

Absatz	EN 840-1: 2020	Messergebnisse - Bemerkungen	Bewertung
Clause	Anforderungen - Prüfungen / Requirements - Tests	Measuring results - Remarks	Evaluation

Table 4 — Dimensions for containers - Class II (>200 l)

Dimensions in millimetres

Dimension N°	Class II a		Class II b	Class II c ^d		Class II d		Remarks
	Type a	Type b		Type a ^b	Type b ^c	Type a ^c	Type b ^c	
1 ^a	546 ± 5		580 ± 5	640 max.	665 max.	755 ⁺⁵ ₋₁₅		Total width of the container
2 ^a	546 ± 5	480 ± 5	580 ± 5	590 +10/ -25	565 min 655 max.	745 ⁺⁵ ₋₁₅	660 ± 10	Width of the frontal receiver
3	730 max.		740 max.	880 max.		810 max.		
4	1 100 max.		1 100 max.	1 115 max.		1 100 max.		Total height including handles on the lid
5 ^a	860 min.; 1 030 max.		860 min.; 1 030 max.	860 min.; 1 030 max.		860 min.; 1 030 max.		
6	565 max.		590 max.	650 max.		775 max.		
7	1 180 max.		1 190 max.	1 250 max.		1 200 max.		
8	560 min.; 760 max.		560 min.; 760 max.	560 min.; 760 max.		560 min.; 760 max.		For 300 mm wheels, the maximum dimension is 70 mm more.
10	515 ± 15		430 ⁺²⁰ ₋₃₀	565 max.		722 ± 5		
11 ^a	200 ⁺¹ ₋₅		200 ⁺¹ ₋₅	200 ⁺¹ ₋₅		200 ⁺¹ ₋₅		Larger wheels accepted
12 ^a	19 min.		19 min.	19 min.		19 min.		
13 ^a	6 ⁺² _{-4,5}		6 ⁺² _{-4,5}	6 ⁺² _{-4,5}		6 ⁺² _{-4,5}		
15 ^a	13 ⁺⁵ ₋₃		13 ⁺⁵ ₋₃	13 ⁺⁵ ₋₃		13 ⁺⁵ ₋₃		
16 ^a	21 ⁺² ₋₂		21 ⁺² ₋₂	21 ⁺² ₋₂		21 ⁺² ₋₂		
18 ^a	26 ± 1		26 ± 1	26 ± 1		26 ± 1		
19 ^a	58 max.		58 max.	58 max.		58 max.		
20 ^a	20 min.		20 min.	20 min.		20 min.		
21 ^a	130 max.		130 max.	130 max.		130 max.		
22	15 max.		15 max.	15 max.		15 max.		
23 ^a	33 ⁺⁸ ₀		33 ⁺⁸ ₀	33 ⁺⁸ ₀		33 ⁺⁸ ₀		
26 ^a	291 ± 5	180 ± 5	291 ⁺³ ₋₅	300 ⁺⁵ ₋₁₀		390 ⁺⁵ ₋₁₀	291 ± 5	Compulsory dimensions when ribs are fitted, max. ribs thickness 6 mm. A middle rib is only allowed with class

Prüfbericht-Nr.: HU26KKKQ 001
Test Report No.:

Seite 13 von 49
Page 13 of 49

Absatz	EN 840-1: 2020	Messergebnisse - Bemerkungen	Bewertung
Clause	Anforderungen - Prüfungen / Requirements - Tests	Measuring results - Remarks	Evaluation

Dimen- sion N°	Class II a		Class II b	Class II c ^d		Class II d		Remarks
	Type a	Type b		Type a ^b	Type b ^c	Type a ^c	Type b ^c	
								II a type a, class II b, class II c, class II d type b.
27	270° min.		270° min.	270° min.		270° min.		
28	525 min.	445 min.	545 min.	554 min.	549 min.	714 min.	630 min.	The dimension No 28 has to correspond to Figure 3 and the lifting device. Definition in accordance with comb dimension, standard and identification character of EN 1501-5:—.
<p>* Compulsory dimensions for functional and safety reasons. The other dimensions indicated are suggested recommended values.</p> <p>^b Lifting device with comb width 1 280 mm (EN 1501-5:—): 2 containers can be emptied at the same time.</p> <p>^c Lifting device with comb width 1 280 mm (EN 1501-5:—): only 1 single container can be emptied.</p> <p>^d It is recommended not to design new containers within this class II c type b.</p> <p>NOTE Dimensions 9, 14, 17, 24 and 25 are no longer used and have been deleted from the table as a result.</p>								

Prüfbericht-Nr.: HU26KKKQ 001
Test Report No.:

Seite 14 von 49
Page 14 of 49

Absatz	EN 840-1: 2020	Messergebnisse - Bemerkungen	Bewertung
Clause	Anforderungen - Prüfungen / Requirements - Tests	Measuring results - Remarks	Evaluation

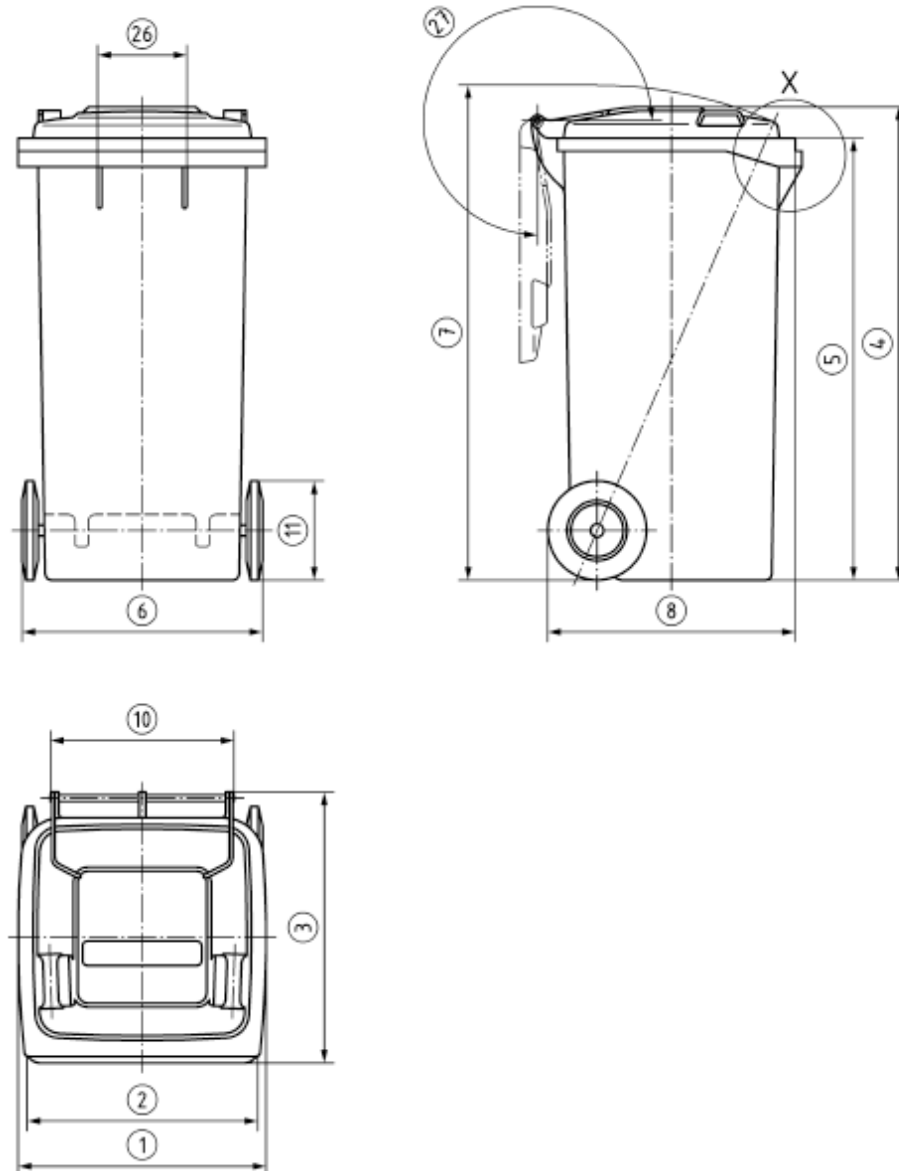

NOTE For more details regarding the dimensions, see Tables 3 and 4.

Figure 1 — System dimensions

Prüfbericht-Nr.: HU26KKKQ 001
Test Report No.:

Absatz	EN 840-1: 2020	Messergebnisse - Bemerkungen	Bewertung
Clause	Anforderungen - Prüfungen / Requirements - Tests	Measuring results - Remarks	Evaluation

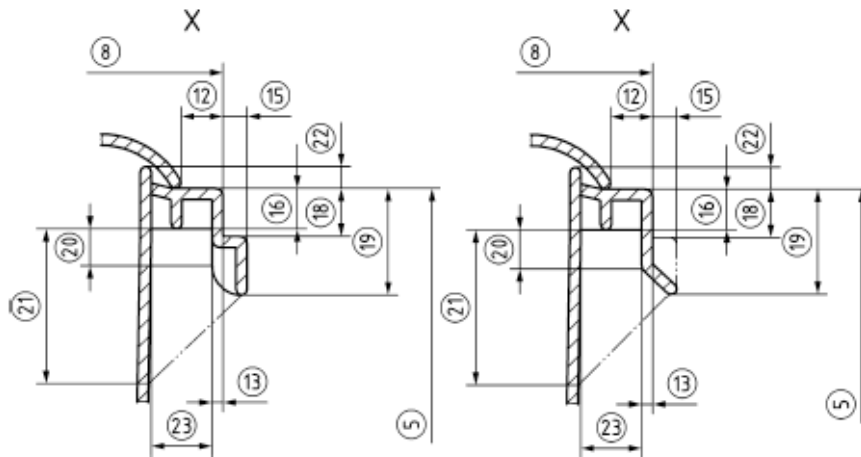

Key

- A Form A
- B Form B

NOTE For more details regarding the dimensions, see Tables 3 and 4.

Figure 2 — Frontal receiver

Dimensions in millimetres

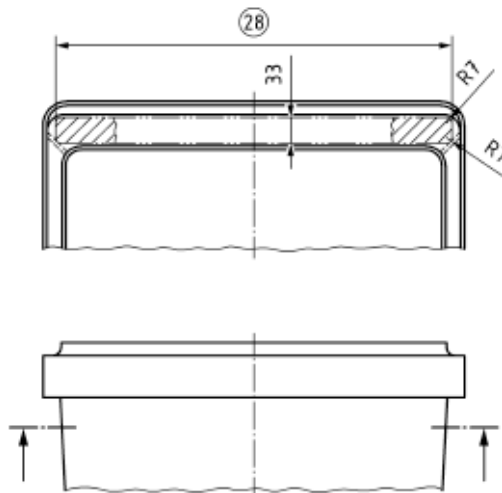

NOTE Depth 33 mm keep in mind minimum width (28). The width can be interrupted by centering ribs if ribs are present. Dimension (28) is to measure with suitable measuring equipment. For more details regarding the dimensions, see Tables 3 and 4.

Figure 3 — Functional dimension for frontal receivers

Prüfbericht-Nr.: HU26KKKQ 001
Test Report No.:

Seite 16 von 49
Page 16 of 49

Absatz <i>Clause</i>	EN 840-1: 2020 <i>Anforderungen - Prüfungen / Requirements - Tests</i>	Messergebnisse - Bemerkungen <i>Measuring results - Remarks</i>	Bewertung <i>Evaluation</i>
-------------------------	--	--	--------------------------------

A	Annex A (informative) - Nomenclature
	See DIN EN 840-1:2020

Prüfbericht-Nr.: HU26KKKQ 001

Test Report No.:

Absatz	EN 840-5:2020	Messergebnisse - Bemerkungen	Bewertung
Clause	Anforderungen - Prüfungen / Requirements - Tests	Measuring results - Remarks	Evaluation

	Scope		
	<p>This European Standard gives the test methods for mobile waste and recycling containers according to EN 840-1 to EN 840-4. It also gives the levels to be reached during the tests or after they have been done.</p> <p>This European Standard is applicable to mobile waste and recycling containers with capacities up to 1 700 l.</p>		
2	Normative references		
	See DIN EN 840-5:2020		
3	Terms and definitions		
	See EN 840-5:2020		
4	Tests		
4.1	General		
	<p>Before and after the tests a visual inspection of the container shall be done for the purpose of:</p> <p>a) checking that the container is not damaged and has no visual defect; b) checking that the manufacturing characteristics of the container to be tested are those specified in the standards applying to the container according to EN 840-1 to EN 840-4; c) comparing the condition of the container before and after the sequence of the tests.</p> <p>After completing the tests some deformation of the container is permissible, however, it shall remain entirely functional.</p>		
4.2	Control before the tests		
4.2.1	Visual aspects		
	No obvious damage, cracks, bubbles, large flashes or sharp edges shall be present. No surface defects (unsmooth areas; trails in colour) perceivable from a distance of 1 m by the naked eye shall be visible.	No damage, cracks or any visible deformation or sharp edges can be found on the sample.	P <input checked="" type="checkbox"/> F <input type="checkbox"/> N/A <input type="checkbox"/> N/T <input type="checkbox"/>

Prüfbericht-Nr.: HU26KKKQ 001

Test Report No.:

Absatz	EN 840-5:2020	Messergebnisse - Bemerkungen	Bewertung
Clause	Anforderungen - Prüfungen / Requirements - Tests	Measuring results - Remarks	Evaluation

4.2.2	Compatibility with EN 840-1 to EN 840-4		
4.2.2.1	Components		
	Body, lid, wheels and other fittings shall conform to the relevant container standard.	Please refer test report of EN 840-1, -5, -6	P <input checked="" type="checkbox"/> F <input type="checkbox"/> N/A <input type="checkbox"/> N/T <input type="checkbox"/>
4.2.2.2	Sizes and dimensions		
	Functional and safety dimensions for the container and its components shall be checked according to the figures and the relevant tables of EN 840-1 to EN 840-4.	Please refer test report of EN 840-1 (For dimensions, see on page 49)	P <input checked="" type="checkbox"/> F <input type="checkbox"/> N/A <input type="checkbox"/> N/T <input type="checkbox"/>
4.2.2.3	Volumes		
	The volumes of container shall be measured: a) for the body, by tank method; b) for the lid, by tank method; c) volume results in a) and b) minus any duplicated volumes. The volumes shall be within the tolerances according to EN 840-1 to EN 840-4. For containers according to EN 840-3 volume measurement by means of calculation is allowed.	The container is within the limit acc to EN 840-1:2020, Table 1.	P <input checked="" type="checkbox"/> F <input type="checkbox"/> N/A <input type="checkbox"/> N/T <input type="checkbox"/>

Prüfbericht-Nr.: HU26KKKQ 001

Test Report No.:

Absatz	EN 840-5:2020	Messergebnisse - Bemerkungen	Bewertung
Clause	Anforderungen - Prüfungen / Requirements - Tests	Measuring results - Remarks	Evaluation

4.2.2.4 Tank method

	<p>The test equipment shall consist of a tank with sufficient capacity to receive the container to be tested. The test procedure is as follows:</p> <ul style="list-style-type: none"> - place the empty container in a tank, the container shall not be inclined; - simultaneously fill the tank and the container with water at a temperature of $(15 \pm 5)^{\circ}\text{C}$; - measure the quantity of water inside the container. <p>Accuracy of measurement shall be $\pm 1\%$ of the measured capacity of the container.</p>	<p>The container is within the limit acc to EN 840-1:2020, Table 1. <u>240 l container: 235 l – 255 l</u> Wave bin 240 l: Body: 237 l + Lid: 13 l => sum: 250 l</p>	<p>P <input checked="" type="checkbox"/></p> <p>F <input type="checkbox"/></p> <p>N/A <input type="checkbox"/></p> <p>N/T <input type="checkbox"/></p>
--	--	--	--

4.2.3 Deflection for comb lifting system

	<p>The frontal receiver shall have a horizontal deflection of no more than:</p> <ul style="list-style-type: none"> a) 1,5 % of the length of the frontal receiver for plastic; b) 0,6 % of the length for steel. <p>For other systems the values are to be defined when the systems are standardised.</p>	<p>Max. allowed deflection acc. to this standard is 1,5% of P2</p> <p>The deflection is under the max. allowed value: Wave bin 240 l: 0,7 mm</p>	<p>P <input checked="" type="checkbox"/></p> <p>F <input type="checkbox"/></p> <p>N/A <input type="checkbox"/></p> <p>N/T <input type="checkbox"/></p>
--	---	--	--

4.2.4 Masses

	<p>The tolerances on the container mass claimed are as follows: for plastic containers $\pm 5\%$ and for metal containers $\pm 10\%$.</p>	<p>Max allowed difference between the samples and the claimed masses: $\pm 5\%$ Measured weights (without the wheels and axle): 8,66 kg; 8,66 kg With wheel, lid, axle: 12,44 kg, 12,42 kg, 12,46 kg, 12,38 kg claimed (manual): 12,8 kg The weights are between: 12,15 kg – 13,44 kg</p>	<p>P <input checked="" type="checkbox"/></p> <p>F <input type="checkbox"/></p> <p>N/A <input type="checkbox"/></p> <p>N/T <input type="checkbox"/></p>
--	---	--	--

Prüfbericht-Nr.: HU26KKKQ 001

Test Report No.:

Absatz	EN 840-5:2020	Messergebnisse - Bemerkungen	Bewertung
Clause	Anforderungen - Prüfungen / Requirements - Tests	Measuring results - Remarks	Evaluation

4.2.5	Colour		
	The colour shall be defined and agreed between customer and supplier. For colour measurement, differences and tolerances refer to existing International Standards.		
4.2.6	Marking		
	Marking of the container shall correspond to EN 840-1 to EN 840-4.	Please refer test report of EN 840-1 (See at pages 3 and EN 840-1:2020, clause 9.1 on page 8)	P <input checked="" type="checkbox"/> F <input type="checkbox"/> N/A <input type="checkbox"/> N/T <input type="checkbox"/>
4.3	Control after the tests		
	Not withstanding variations in deflection and sizes, it shall be possible to lift and tilt the container loaded according to 4.5 with nominal load safely on the designated lifting equipment and to move the container on its wheels.	The loaded samples were possible to lift and tilt with the lifting equipment and move on its wheels.	P <input checked="" type="checkbox"/> F <input type="checkbox"/> N/A <input type="checkbox"/> N/T <input type="checkbox"/>
4.4	Conditions of the test		
	The tests shall be carried out at the following temperatures: — $T_1 = (23 \pm 5) ^\circ\text{C}$ — $T_2 = (-18_{-2}^0) ^\circ\text{C}$. The minimum duration of conditioning before testing at a test temperature T2 shall be 12 h. If the test shall be carried out outside the room conditioned at T2 it shall be carried out within 5 min after taking the test pieces from the conditioned room. If the duration of the tests is more than 5 min, then the container shall be kept in the conditioned room for at least 15 min before a new 5 min period of testing. For special purposes a temperature lower than -18 °C or higher than 23 °C can be agreed; in this case it shall be indicated in the test report.		

Prüfbericht-Nr.: HU26KKKQ 001

Test Report No.:

Absatz	EN 840-5:2020	Messergebnisse - Bemerkungen	Bewertung
Clause	Anforderungen - Prüfungen / Requirements - Tests	Measuring results - Remarks	Evaluation

4.5	Test load		
	<p>For the test the containers are to be filled with ballast bags of HDPE granules of 4 kg max., with granules having a density of 0,5 kg/dm³.</p> <p>The test load shall be 0,4 kg/dm³ multiplied by nominal volume, but not more than 440 kg.</p>		
4.6	Other test conditions		
	Any other test conditions shall be defined within the tests involved.		
4.7	Tests on the containers		
4.7.1	General		
	All tests shall be carried out on new containers		
4.7.2	Impact tests by ball drop		
	<p>The ball drop test is not compulsory for steel containers.</p> <p>The ability of sensitive points of the container to resist impacts at low temperature shall be tested under conditions in 4.4.</p> <p>The 2-wheeled containers shall be placed on a concrete or steel surface in the normal position.</p> <p>There shall be a steel frame between the concrete surface or the steel surface and the container so that the complete area of the bottom of the container can be deflected during the test.</p> <p>The 4-wheeled containers shall stand on their wheels.</p> <p>Ball drop tests shall be carried out using a 5 kg steel cylinder, diameter 65 mm, with hemispheric end radius of 32,5 mm. The steel cylinder is guided in a vertical pipe with a slot or with holes in order to allow the air to escape during the drop.</p> <p>The device shall be according to Figure 1.</p>	<p>Drop height: 0,8 m</p> <p>There is no crack or broke on the samples after the drops. The containers are still waterproof.</p>	<p>P <input checked="" type="checkbox"/></p> <p>F <input type="checkbox"/></p> <p>N/A <input type="checkbox"/></p> <p>N/T <input type="checkbox"/></p>

Prüfbericht-Nr.: HU26KKKQ 001

Test Report No.:

Absatz	EN 840-5:2020	Messergebnisse - Bemerkungen	Bewertung
Clause	Anforderungen - Prüfungen / Requirements - Tests	Measuring results - Remarks	Evaluation

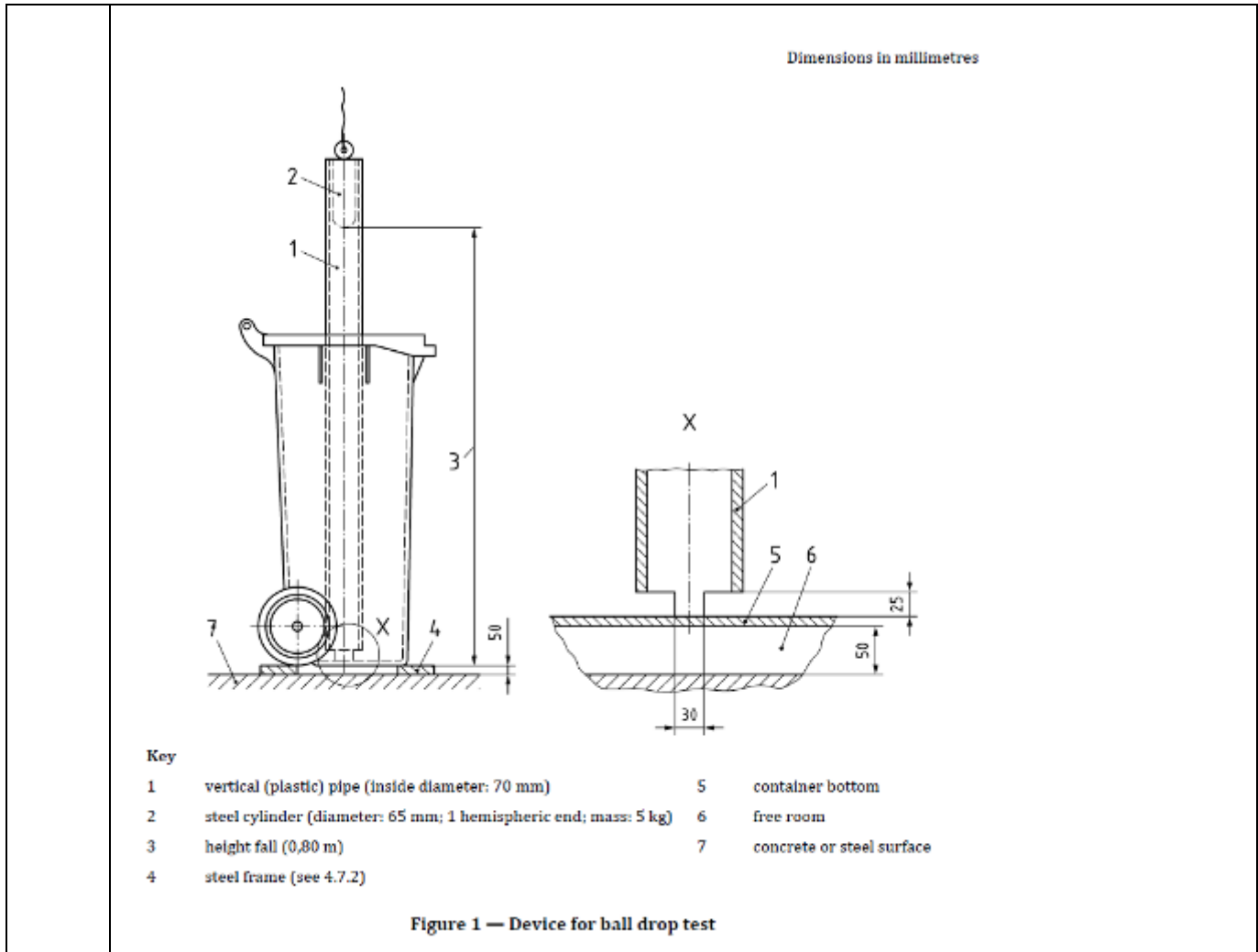

<p>The following areas of containers shall be tested by impact tests:</p> <p>a) on the body bottom (see Figure 2 d) there shall be 3 successive impacts for each impact point defined below:</p> <p style="margin-left: 40px;">1) the injection point(s), 2) A and D or C and B.</p> <p>after the test the container shall be waterproof in the tested points;</p>	
--	--

Prüfbericht-Nr.: HU26KKKQ 001

Test Report No.:

Absatz Clause	EN 840-5:2020 Anforderungen - Prüfungen / Requirements - Tests	Messergebnisse - Bemerkungen Measuring results - Remarks	Bewertung Evaluation
------------------	---	---	-------------------------

- b) there shall be 2 successive impacts for each impact point defined below (see Figures 2a), 2b), 2c))
- 1) the centre of the lid (E),
 - 2) one corner of the lid (cylinder to be tangent to the lid) (F),
 - 3) the corner diametrically opposite (cylinder to be tangent to the lid) (G),
 - 4) each hinge (H),
 - 5) the centre of the front face of the top rim (J),
 - 6) the centre of a lateral face of the top rim (I),
 - 7) the back corner opposite the lateral face previously tested of the top rim (K),
 - 8) centre of any handle (L, see Figure 2c) key 2).

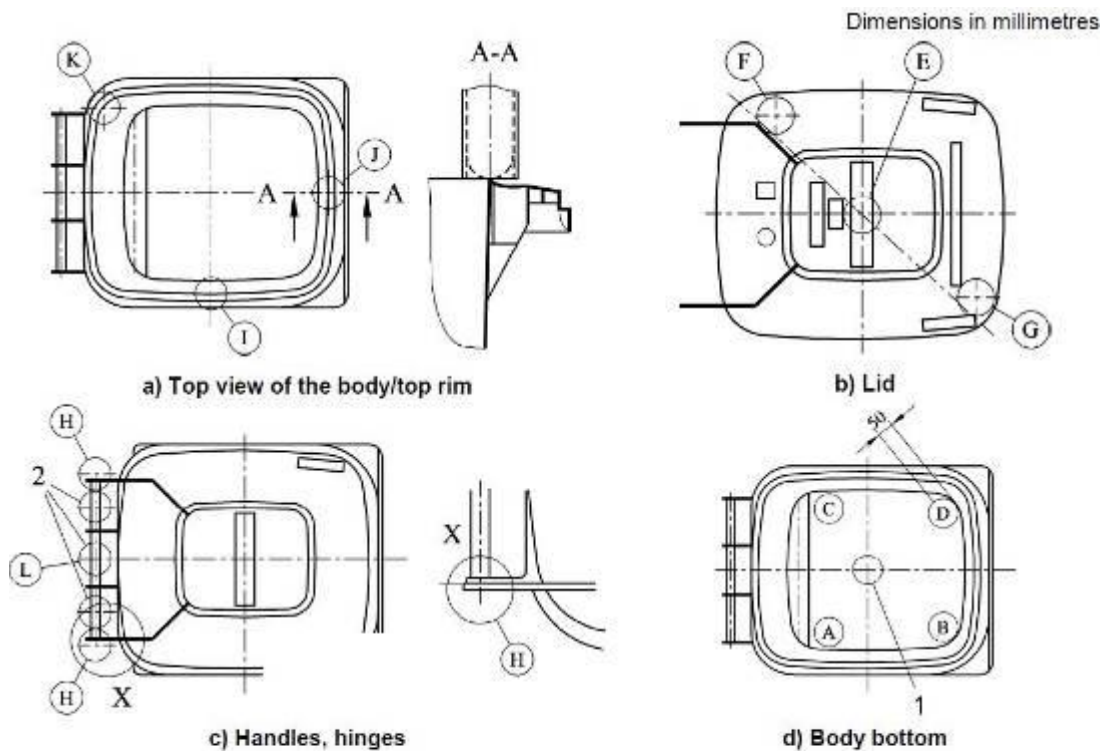

- Key**
- 1 injection point
(if one injection point only, impact on it and on A - D or B - C)
 - 2 middle of handle

Figure 2 — Impact points for ball drop test

Prüfbericht-Nr.: HU26KKKQ 001

Test Report No.:

Absatz Clause	EN 840-5:2020 Anforderungen - Prüfungen / Requirements - Tests	Messergebnisse - Bemerkungen Measuring results - Remarks	Bewertung Evaluation
------------------	---	---	-------------------------

	<p>Outside of the conditioning room (see 4.4), the test shall not last more than 5 min. After this time the container shall be reconditioned for at least 15 min.</p> <p>After the test the following procedure shall be applied, if there is any doubt about the result:</p> <ul style="list-style-type: none"> - fill the body with a water volume equal to 10 % of the maximum capacity of the body; - wait for 10 min. <p>After 10 min, if the container leaks, it is declared to be non conforming.</p>		
--	--	--	--

4.7.3 Impacts on an inclined plane

	<p>Only 4-wheeled containers shall be tested with impact on each wall of the body and on each corner to check the resistance to straining and breaking of sensitive areas, including protruding areas and fittings. The test conditions shall be:</p> <ul style="list-style-type: none"> - test temperature T1= room temperature; - test load according to 4.5; - inclination of 10°(ten degrees) to the horizontal; - impact against a wall perpendicular to the moving direction; - a total of 16 impacts according to the sequence in Table 1. <p>During the procedure the lid shall be closed. The loaded container shall be placed on a trolley with an inclination of 10°(ten degrees) (relative to the horizontal). Precautions shall be taken to avoid accidental tipping of the container during the test (see Figure C.1).</p> <p>Other apparatus than shown in Figure C.1 may be used if it allows the same impact and velocity conditions.</p> <p>The impact velocity shall be (1,85 ± 0,05) m/s when a face is tested and (1,3 ± 0,05) m/s when a corner is tested.</p> <p>The vertical faces of the container will be numbered from 1 to 4 and the face marked 1 being the large face fitted for the (comb) lifting system. Corners are marked 1.2, 2.3, 3.4 and 4.1.</p> <p>After completing the test some deformation of the container is permissible, however, it shall remain entirely functional.</p>	<p>2-wheeled container</p>	<p>P <input type="checkbox"/></p> <p>F <input type="checkbox"/></p> <p>N/A <input checked="" type="checkbox"/></p> <p>N/T <input type="checkbox"/></p>
--	---	----------------------------	--

Prüfbericht-Nr.: HU26KKKQ 001

Seite 25 von 49

Test Report No.:

Page 25 of 49

Absatz	EN 840-5:2020	Messergebnisse - Bemerkungen	Bewertung
Clause	Anforderungen - Prüfungen / Requirements - Tests	Measuring results - Remarks	Evaluation

Table 1 — Sequence of the lateral impacts

Impact n°	Face or corner tested	No of impacts
1 to 2	Face 1	2
3 to 4	Corner 1.2	2
5 to 6	Face 2	2
7 to 8	Corner 2.3	2
9 to 10	Face 3	2
11 to 12	Corner 3.4	2
13 to 14	Face 4	2
15 to 16	Corner 4.1	2

4.7.4	Kerb travel (run)		
	<p>Only 4-wheeled containers shall be tested for kerb travel using run tests under the following conditions:</p> <ul style="list-style-type: none"> - test shall be carried out at room temperature T1; - test load according to 4.5; - apparatus shall comply with Annex A; - kerb height shall be 140 mm orthogonal to the moving direction and located at the end of the run; - wheels are to be guided in order to be orthogonal to the kerb at the time of the impact; - impact velocity shall be $(1,85 \pm 0,05)$ m/s; - there shall be 4 impacts for each of the shorter ends of the container (8 in total). <p>After the test there shall be no permanent deformation or breakage which disturbs handling, tilting, rolling (castors move freely).</p>	2-wheeled container	P <input type="checkbox"/> F <input type="checkbox"/> N/A <input checked="" type="checkbox"/> N/T <input type="checkbox"/>
4.7.5	Kerb travel (drops)		
4.7.5.1	General		
	<p>Strength tests shall be carried out on 2- and 4-wheeled containers under the following conditions:</p> <ul style="list-style-type: none"> - test temperature T1 = room temperature; - test load according to 4.5; - height fall of 140 mm. <p>The container shall be lifted up to 140 mm and then dropped freely so that 2 wheels hit the ground first.</p> <p>After the test there shall be no permanent deformation or breakage, which disturbs handling, tilting, rolling or safety and health (castors shall move freely).</p>		

Prüfbericht-Nr.: HU26KKKQ 001

Test Report No.:

Absatz	EN 840-5:2020	Messergebnisse - Bemerkungen	Bewertung
Clause	Anforderungen - Prüfungen / Requirements - Tests	Measuring results - Remarks	Evaluation

4.7.5.2	Test conditions		
	<p>- 2 wheels shall hit the ground; - at least 1 000 drops shall be carried out; - number of 5 drops per minute maximum; - test apparatus shall be according to Figure B.1 and B.2.</p> <p>After the test there shall be no permanent deformation or breakage which disturbs handling, tilting, rolling (castors move freely).</p>	<p>Results are taken from test report HU26MNUK 001, 2026-05-08. The container was made from the same material, with the same accessories (wheel, axle): Wave 120 I: Loaded with nominal load: 48 kg Drop height: 140 mm Cycles: 1000</p> <p>There is no permanent deformation or breakage which disturbing handling, tilting or rolling safely.</p>	<p>P <input checked="" type="checkbox"/> F <input type="checkbox"/> N/A <input type="checkbox"/> N/T <input type="checkbox"/></p>
4.8	Stability test		
	<p>The static stability of empty and loaded containers on a flat plane of 10°(ten degrees) to the horizontal shall be tested at first on empty containers and after that on containers filled with the nominal load.</p> <p>The test shall be carried out without wind.</p> <p>For 4-wheeled containers, the brakes, if any, could prevent them from rolling. Other arrangements shall be made to prevent containers from gliding or rolling without hindering tipping.</p> <p>The container shall be checked in 3 directions.</p> <p>a) Stability at right angles to the slope line (transversal stability): the wider part of 4-wheeled containers and the wheel's axle of 2-wheeled containers shall be parallel to the slope line.</p> <p>b) Longitudinal stability: the wider part of 4-wheeled containers and the wheel's axle of 2-wheeled containers shall be in the right angle to the slope line.</p> <p>c) Diagonal stability: the diagonal line of the container shall be parallel to the slope line.</p> <p>The longitudinal stability test of 4-wheeled containers includes the brake test according to 4.9.4. In consideration of all test conditions the container shall neither tip nor move.</p>	<p>Loaded with nominal load acc. clause 6 on page 7: 240 l – 96 kg</p> <p>Inclination: 10°</p> <p>The containers did not tip over empty, nor loaded with the nominal load, tested in the 3 required directions.</p>	<p>P <input checked="" type="checkbox"/> F <input type="checkbox"/> N/A <input type="checkbox"/> N/T <input type="checkbox"/></p>

Prüfbericht-Nr.: HU26KKKQ 001

Test Report No.:

Absatz	EN 840-5:2020	Messergebnisse - Bemerkungen	Bewertung
Clause	Anforderungen - Prüfungen / Requirements - Tests	Measuring results - Remarks	Evaluation

4.9	Pulling and rolling tests		
4.9.1	General		
	<p>The aim of these tests is to check the handling and immobilisation of the containers and to fulfil the safety and health requirements for the operators. These tests shall include:</p> <ul style="list-style-type: none"> - pulling tests; - wheels tests; - brake tests. 		
4.9.2	Pulling tests		
	<p>The strength required to start and maintain the container movement shall be measured (regarding the apparatus, see Figure 3). The pulling forces defined as horizontal forces in pulling direction are measured and the result shall be stated in the instructions for use.</p> <p>In order to get comparable results all tests shall be carried out under the following conditions:</p> <ul style="list-style-type: none"> a) new container (loaded according to 4.5); b) ground shall be a plane, smooth concrete horizontal surface (slope = 1°(one degree) maximum); c) pulling force direction shall be horizontal ± 2° (two degrees) to all sides; d) pulling speed shall be 0,1 m/s ± 0,005 m/s; e) pulling distance shall be 3 m minimum; f) temperature in the test area and of the tested container shall be T1; g) total tolerance range of measuring equipment shall be ± 3 % of the measured value; h) preparation of the tested container before every test shall be: <ul style="list-style-type: none"> 1) 2-wheeled containers shall be in a tilted position where the strength for a handle is 20% of the force (Newton), created by the container's total permissible mass (kilograms), 2) 4-wheeled containers shall have the wheels aligned in the pulling direction. The direction block, if fitted, shall be in operation; i) tests shall be carried out 3 times. <p>The test is passed if the maximum pulling forces according to Table 2 are not exceeded.</p>	<p>Pulling forces were smaller than ≤ 60N on the sample.</p> <p>The representative samples were loaded with nominal load acc. to EN 840-1, clause 6 on page 7.</p> <p>Wave bin 240 I: 31 N</p>	<p>P <input checked="" type="checkbox"/></p> <p>F <input type="checkbox"/></p> <p>N/A <input type="checkbox"/></p> <p>N/T <input type="checkbox"/></p>

Prüfbericht-Nr.: HU26KKKQ 001

Test Report No.:

Absatz	EN 840-5:2020	Messergebnisse - Bemerkungen	Bewertung
Clause	Anforderungen - Prüfungen / Requirements - Tests	Measuring results - Remarks	Evaluation

Dimensions in millimetres

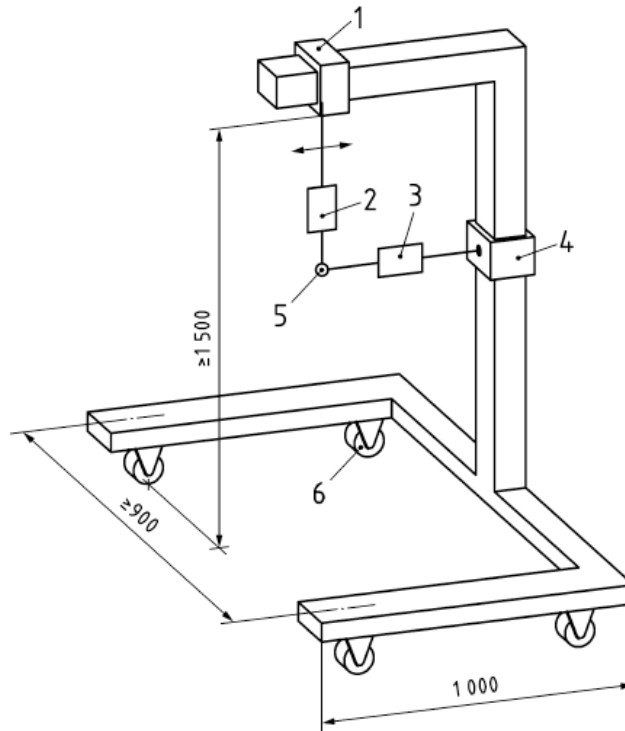

Key

- 1 adjuster
- 2 measuring head for handle lifting force
(20 % of container dead weight)
- 3 measuring head for pulling force in rigid and hinged fittings
- 4 adjuster for the handle height
- 5 handle of container
(2-wheeled container in tilted position)
- 6 swivel castors with direction block

NOTE By using the above testing tool the horizontally measured pulling force is ensured.

Figure 3 — Apparatus for measurement (Example of testing device of 2-wheeled container)

Table 2 — Maximum forces for sustained pulling (up to 1 700 l capacity)

Container	Pulling force N max.
2-wheeled	60
4-wheeled	285
Maximum forces (including initial force) ought to be no more than 300 N, according to some work regulations.	

Prüfbericht-Nr.: HU26KKKQ 001

Test Report No.:

Absatz	EN 840-5:2020	Messergebnisse - Bemerkungen	Bewertung
Clause	Anforderungen - Prüfungen / Requirements - Tests	Measuring results - Remarks	Evaluation

4.9.3 Wheels testing

	<p>The functional qualities of the wheels over a given distance, at a defined speed, under load, with a periodical step shall be tested. It is a test specifically for the wheel.</p> <p>The apparatus shall be a concrete surface horizontal circle with a diameter of 1,1 m.</p> <p>The wheel is rolled in a circle. A step of 11,5 cm height is placed in the circle along a radius and allows the wheel to fall down after each 3,5 m run (1 turn). The wheel is loaded with loads according to Table 3. The test shall be carried out in turns of moving and rest.</p> <p>The test shall be carried out at temperature T1.</p> <p>After completing the test tyres and wheels shall remain functional.</p> <p>After the test there shall be no permanent deformation or breakage, which disturbs handling, tilting, rolling. (castors shall move freely). The hub shall be fully intact with no loosening or breaking of rivets.</p>	<p>Certificates were provided for ⊙200mm wheels.</p> <p>SKZ certificate: SKZ 59314 (2014-03-12) Manufacturer: TW Reifen- und Räderhandels-gesellschaft mbH Artikel-Nr.: 4036.004</p> <p>Test report: 116245/15 (2015-05-27)</p>	<p>P <input checked="" type="checkbox"/></p> <p>F <input type="checkbox"/></p> <p>N/A <input type="checkbox"/></p> <p>N/T <input type="checkbox"/></p>
--	--	---	--

Table 3 — Conditions for testing wheels (200 mm diameter)

Conditions	Wheels for 2-wheeled containers	Wheels for 4-wheeled containers
Number of wheels	2 consecutively	2 consecutively
Load per wheel	40 kg	65 kg
Cycles running time	1 min	5 min
Resting time and again	3 min	5 min
Total distance run	5 km	20 km
Equivalent time	1,5 h	—
Running speed	3,3 km/h	3,3 km/h
Checking of the wheel	at the end of the test	every 3 h

Prüfbericht-Nr.: HU26KKKQ 001

Test Report No.:

Absatz	EN 840-5:2020	Messergebnisse - Bemerkungen	Bewertung
Clause	Anforderungen - Prüfungen / Requirements - Tests	Measuring results - Remarks	Evaluation

4.9.4	Brake tests		
	The container shall not roll on a gradient of 10° to the horizontal under all load conditions.	There is no brake on the container	P <input type="checkbox"/> F <input type="checkbox"/> N/A <input checked="" type="checkbox"/> N/T <input type="checkbox"/>
4.10	Lifting-tilting tests		
4.10.1	General		
	<p>This test checks that the container fits well on lifting devices in agreement with EN 1501-1. The apparatus shall be a compatible standardised lifting device. All lifting attachments of the container shall be tested.</p> <p>The container and the lifting device are on the same plane, on even ground. The test should be carried out under normal service conditions.</p>	<p>The representative containers fit well on the lifting device.</p> <p>Lifting device comply with the series of standards DIN EN 1501.</p> <p>Lifting device: Terberg – Omnidel 313078 Type: TCA-DEL3e</p>	P <input checked="" type="checkbox"/> F <input type="checkbox"/> N/A <input type="checkbox"/> N/T <input type="checkbox"/>

Prüfbericht-Nr.: HU26KKKQ 001

Test Report No.:

Absatz Clause	EN 840-5:2020 Anforderungen - Prüfungen / Requirements - Tests	Messergebnisse - Bemerkungen Measuring results - Remarks	Bewertung Evaluation
------------------	---	---	-------------------------

4.10.2 Lifting-tilting of the empty container

	<p>This is a preliminary test to be done after visual inspection of the container and before the other tests.</p> <p>The test is carried out on an empty container successively with the lid closed.</p> <p>A minimum of 5 lifting-tilting cycles should be completed without damage or malfunction.</p> <p>After completing the tests no damage on any part of the containers, lid, etc, shall be visible with the naked eye. No hindering during the cycles is allowed. If unsuccessful, the test shall be stopped.</p>	<p>The container fits well on the lifting device. No damage or disfunction after 5 lifting-tilting cycles.</p>	<p>P <input checked="" type="checkbox"/></p> <p>F <input type="checkbox"/></p> <p>N/A <input type="checkbox"/></p> <p>N/T <input type="checkbox"/></p>
--	---	--	--

4.10.3 Lifting-tilting of the loaded container

	<p>The test shall be carried out on one sample under the following conditions:</p> <ul style="list-style-type: none"> - test load shall conform to 4.5. A device to prevent the test load from being ejected during the test; - test temperature T1; - at least 100 cycles shall be made. <p>After every 10 cycles a break of 5 min is planned.</p> <p>After completing the test it shall be possible to safely position the container on the lifting device without lifting it by hand.</p> <p>The container shall be locked safely when tilting, during the cycles.</p> <p>After completing the test no permanent deformation or abnormal distortion of the container causing remature ageing and no changes in dimensions that would give handling and lifting difficulties shall appear.</p>	<p>Tested on loaded sample acc. to clause 6 on page 7: 240 l – 96 kg</p> <p>After 100 cycles, it is possible to handle the container safely, put it on the combs of the lifting device. There is no permanent defirmation or abnormal distortion on the containers.</p>	<p>P <input checked="" type="checkbox"/></p> <p>F <input type="checkbox"/></p> <p>N/A <input type="checkbox"/></p> <p>N/T <input type="checkbox"/></p>
--	---	---	--

Prüfbericht-Nr.: HU26KKKQ 001

Test Report No.:

Absatz	EN 840-5:2020	Messergebnisse - Bemerkungen	Bewertung
Clause	Anforderungen - Prüfungen / Requirements - Tests	Measuring results - Remarks	Evaluation

4.11	Miscellaneous tests		
4.11.1	Internal stress-cracking tests (for thermo plastics only)		
	<p>after this test mean use of inadequate material or bad processing conditions. The test shall be carried out under the following conditions:</p> <ul style="list-style-type: none"> - tank large enough to include the whole container; - water bath with 2 % to 3 % in volume a strong detergent, e.g. based of nonyl-phenol-ethoxilate with a number of ethylene oxide (EO) mol greater than or equal to 9; - bath temperature of (70 ± 5)°C; - duration of the bath shall be 48 h. <p>After the test the container shall be rinsed immediately and shall be checked visually only 6 h after the test.</p> <p>After completing the test no cracks or tears in sensitive areas (containers and lids) where they could extend to bring the container out of use, e.g. front rim, handles, grip hinges, wheel junctions, hinges, injection points, reinforcing ribs, rib edges shall be visible.</p> <p>For containers with four wheels a test of segments is allowed with segments of approximately a quarter of a square meter. For the detergent test the following critical area should be sawed from the container and should be tested in accordance with 4.11.1:</p> <ul style="list-style-type: none"> - Wheel suspension (see area 1 in Figure 4): The wheel bracket is to be cut out from the bottom at a height of approx. 500 mm. All wheel suspensions including the screwed in fastening elements and the drain sleeve shall be tested. - Frontal receiver (see area 2 in Figure 4): Both corner parts are to be checked. The area should be 300 mm x 300 mm large. - Hinge area (see area 3 in Figure 4): Both corner parts are to be checked. The area should be 300 mm x 300 mm large. - Lid (see area 4 in Figure 4): An area from the hinges to the injection points is to be tested. 	<p>The test were carried on samples of Wave bin 120 l container as representative samples. The manufacturers location was the same for each containers, the materials, and processing conditions are also the same for each containers. Results are taken from test report HU26MNUK 001, 2026-05-08.</p> <p>Used detergent: Product: FOR CLEAN Manufacturer: Bio-Circle Surface Technology GmbH</p> <p>6 hours later after 48h soaking than rinsed there is no crack visible on the sample.</p>	<p>P <input checked="" type="checkbox"/></p> <p>F <input type="checkbox"/></p> <p>N/A <input type="checkbox"/></p> <p>N/T <input type="checkbox"/></p>

Prüfbericht-Nr.: HU26KKKQ 001

Test Report No.:

Absatz	EN 840-5:2020	Messergebnisse - Bemerkungen	Bewertung
Clause	Anforderungen - Prüfungen / Requirements - Tests	Measuring results - Remarks	Evaluation

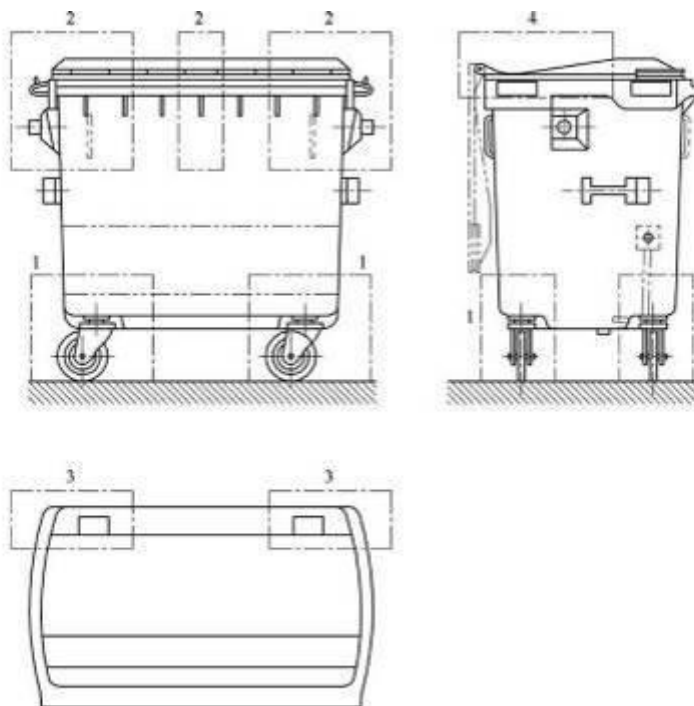

Figure 4 — Segments to be tested

4.11.2 Handle test

Lifting handles on 4-wheeled containers shall be tested. Lifting handles and their junction with the container shall be strong enough to avoid damage or disconnecting when they are used to lift the container up the kerb. The test shall be carried out under the following conditions:

- test temperature T1;
- test load shall conform to 4.5;
- lifting height shall be minimum 50 mm;
- test frequency shall be 5 times per minute with a number of 1 000 liftings at least.

The container shall be lifted at least 50 mm by a 50 mm wide hook which is located around the middle of the handle, and afterwards is slowly moved down to the ground. The test is carried out on one side of the container.

After the test there shall be no permanent deformation or breakage, which disturbs handling the container.

The containers have 2-wheels.

P
 F
 N/A
 N/T

Prüfbericht-Nr.: HU26KKKQ 001

Test Report No.:

Absatz	EN 840-5:2020	Messergebnisse - Bemerkungen	Bewertung
Clause	Anforderungen - Prüfungen / Requirements - Tests	Measuring results - Remarks	Evaluation

4.11.3	Corrosion test		
	<p>The container shall be resistant to corrosion due to the state of the art.</p> <p>It is the task of the manufacturer to use surface treatments or materials which guarantee this performance.</p> <p>Bodies and lids, hot dip galvanised after completion, and other hot dip galvanised parts shall meet the requirements of EN ISO 1461.</p> <p>Zinc electro-plated parts shall meet the requirements of EN ISO 2081.</p> <p>Weldless bodies, lids and parts made out of continuously hot-dip zinc coated steel sheets shall meet the requirements of EN 10142.</p>	<p>Declaration was provided from TW Reifen- und Räderhandelsgesellschaft mbH about compliance with the standard of EN ISO 2081.</p>	<p>P <input checked="" type="checkbox"/></p> <p>F <input type="checkbox"/></p> <p>N/A <input type="checkbox"/></p> <p>N/T <input type="checkbox"/></p>
4.11.4	Weathering (for thermo plastics only)		
	<p>Preparation of samples, conditions of exposures, sequence of exposures, test methods to measure performances of new and irradiated samples are defined in standards to be established by EN/TC 249. In the meantime, ISO standards may be used (see Annex E).</p> <p>The material tested shall contain all the components added to the basic plastic at the rate used to mold the container, stabiliser, pigments or colorants, and, if any, fillers, other plastic etc. These additives may influence the effects of weathering on the plastic.</p> <p>The results of weathering on plastic containers shall include:</p> <ul style="list-style-type: none"> - ageing of the plastic material; - changes in colour. 	<p>Safety data sheet provided</p> <p>Product: CHT GRI 7016 UV LDPE</p> <p>Company: Chimtest Srl.</p> <p>Product: CHT Yellow 1021 UV, CHT GRI 7016 UV</p>	<p>P <input checked="" type="checkbox"/></p> <p>F <input type="checkbox"/></p> <p>N/A <input type="checkbox"/></p> <p>N/T <input type="checkbox"/></p>

Prüfbericht-Nr.: HU26KKKQ 001

Test Report No.:

Absatz Clause	EN 840-5:2020 Anforderungen - Prüfungen / Requirements - Tests	Messergebnisse - Bemerkungen Measuring results - Remarks	Bewertung Evaluation
------------------	---	---	-------------------------

4.11.5	Test method for dome lid container (EN 840-3)		
4.11.5. 1	Equipment		
	<p>— A child mannequin, recommended to be in compliance with an appropriate European Regulation²; size corresponding to 10 years old. The child mannequin is dressed with a thin sweatshirt made of at least 90 % cotton. The child mannequin is wearing the hood.</p> <p>— A parallel piped-shaped plastic box (dimensions: length 600 mm x width 400 mm x height 320 mm).</p> <p>²) ECE R44: European Regulation N° 44 incl. amendment 1; <i>Uniform provisions concerning the approval of retaining devices for child occupants of power-driven vehicles ('child restraints systems')</i>.</p>		
4.11.5. 2	Test method		
	<p>The test described below shall be performed five times for each of the following three child mannequin positions in relation to the container rim:</p> <ul style="list-style-type: none"> - center; - left hand side; - right hand side. <p>The untested dome lid braked container is placed on a hard concrete plane with an inclination of 1° maximum to the horizontal.</p> <p>Position the legs of the child mannequin on the plastic box, such that the head and arms are inside the container for the centre position and one arm inside the container for the lateral position. Close the lid manually until it stops without any unlocking. Remove the box by device at a speed of 0,5 m/s.</p>		

Prüfbericht-Nr.: HU26KKKQ 001

Test Report No.:

Absatz	EN 840-5:2020	Messergebnisse - Bemerkungen	Bewertung
Clause	Anforderungen - Prüfungen / Requirements - Tests	Measuring results - Remarks	Evaluation

4.11.5. Acceptance criteria
3

In each of the three positions, in any sequence of the test, the child mannequin shall fall from the container when the plastic box is removed.

It is acceptable for the child mannequin's head to remain suspended for an amount of time not to exceed 2 s.

Flat lid

P
F
N/A
N/T

4.11.6 Sequence of the tests

The sequence of the tests on each sample are defined by Table 4.

Table 4 — Sequence of the tests

Subclause	Test	2-wheeled containers					4-wheeled containers						
		Sample 1		Sample 2		Other samples	Sample 1		Sample 2		Sample 3		Other samples
		plastic	metal	plastic	metal		plastic	metal	plastic	metal	plastic	metal	
4.2.1	General inspection	0	0	-	-	-	0	0	-	-	-	-	-
4.2.2.2	Measurement	1	1	-	-	-	1	1	-	-	-	-	-
4.7.2	Ball drop	-	-	1	-	-	-	-	1	-	-	-	-
4.7.3	Impact	-	-	-	-	-	8	8	-	-	-	-	-
4.7.4	Kerb run	-	-	-	-	-	9	9	-	-	-	-	-
4.7.5	Kerb drops	6	6	-	-	-	-	-	-	1	1	-	-
4.8	Stability	4	4	-	-	-	4	4	-	-	-	-	-
4.9.2	Pulling	2	2	-	-	-	2	2	-	-	-	-	-
4.9.3	Wheels	-	-	-	-	wheels sample	-	-	-	-	-	-	wheels sample
4.9.4	Brakes	-	-	-	-	-	5	5	-	-	-	-	-
4.10.2	Lifting empty	3	3	-	-	-	3	3	-	-	-	-	-
4.10.3	Lifting loaded	5	5	-	-	-	7	7	-	-	-	-	-
4.11.1	Internal stress	-	-	S	-	S	-	-	S	-	-	-	S
4.11.2	Handles	-	-	-	-	-	6	6	-	-	-	-	-
4.11.3	Corrosion	-	-	2	2	section	-	-	2	2	-	-	-
4.11.4	Weathering	-	-	-	-	S	-	-	-	-	-	-	S
4.11.5	Dome lid	-	-	-	-	-	1	1	-	-	-	-	-

S special new parts:
- for internal stress: on body and lid
- for weathering: on body and lid, or parts of them, or standardized samples

Testing unit: - for 2-wheeled containers 2 regular samples and 2 special ones are required;
- for 4-wheeled containers 3 regular samples and 2 special ones are required.

Prüfbericht-Nr.: HU26KKKQ 001

Seite 37 von 49

Test Report No.:

Page 37 of 49

Absatz	EN 840-5:2020	Messergebnisse - Bemerkungen	Bewertung
Clause	Anforderungen - Prüfungen / Requirements - Tests	Measuring results - Remarks	Evaluation

5	Test report
	See DIN EN 840-5:2020
A-F	Annex A - Annex E see DIN EN 840-5:2020
	<p>Annex A (informative) - Slope and stop for "kerb travel" test Annex B (informative) - Apparatus for kerb fall test Annex C (informative) - Apparatus for lateral impact test on inclined plane Annex D (informative) - Wheel Test Annex E (informative) - Weathering tests</p>

Prüfbericht-Nr.: HU26KKKQ 001 <i>Test Report No.:</i>			
Absatz	EN 840-6:2020	Messergebnisse - Bemerkungen	Bewertung
Clause	Anforderungen - Prüfungen / Requirements - Tests	Measuring results - Remarks	Evaluation
1	Scope		
	This document provides the essential safety, health and ergonomic requirements for mobile waste and recycling containers according to EN 840-1:2020 to EN 840-4:2020, not including hazardous wastes containers.		
2	Normative references		
	<p>The following documents are referred to in the text in such a way that some or all of their content constitutes requirements of this document. For dated references, only the edition cited applies. For undated references, the latest edition of the referenced document (including any amendments) applies.</p> <p>EN 840-5:2020, <i>Mobile waste and recycling containers — Part 5: Performance requirements and test methods</i></p>		
3	Terms and Definitions		
	See DIN EN 840-6:2020		
4	General requirements of construction		
4.1	<p>The container shall be constructed so that when it is unloaded or loaded with a nominal mass, it has a secure fit on an approved compatible lifting device and shall be automatically locked safely into the lifting device during the tilting and emptying operation. The container shall be in static stability according to 4.8 of EN 840-5:2020.</p>	<p>See at clause 4.10 from page 30 and for stability at clause 4.8 on page 26.</p>	P <input checked="" type="checkbox"/> F <input type="checkbox"/> N/A <input type="checkbox"/> N/T <input type="checkbox"/>

Prüfbericht-Nr.: HU26KKKQ 001
Test Report No.:

Absatz Clause	EN 840-6:2020 Anforderungen - Prüfungen / Requirements - Tests	Messergebnisse - Bemerkungen Measuring results - Remarks	Bewertung Evaluation
4.2	The container shall be safely fitted to the lifting device of the vehicle without being carried or lifted manually.	See at clause 4.10 from page 30.	P <input checked="" type="checkbox"/> F <input type="checkbox"/> N/A <input type="checkbox"/> N/T <input type="checkbox"/>
4.3	Wheeled containers shall be constructed so that, under test conditions according to EN 840-5, the pushing and pulling forces to keep the container moving shall not exceed the values given in EN 840-5:2020, 4.9. Pushing and pulling forces shall be declared in the instructions for use (see Clause 12).	Refer to EN 840-5:2020, clause 4.9.2, page 27	P <input checked="" type="checkbox"/> F <input type="checkbox"/> N/A <input type="checkbox"/> N/T <input type="checkbox"/>
4.4	During construction of containers the following factors influencing measurable handling force shall be optimized: - design of container as regards to form, size and position of centre of gravity in relation to positioning of wheels and handles; - even distribution of loads on wheels; - low rolling resistance.	for reference Dimensions correspond to the requirements, easy to handle. Pulling and rolling test – see 4.9.2 at page 27	P <input checked="" type="checkbox"/> F <input type="checkbox"/> N/A <input type="checkbox"/> N/T <input type="checkbox"/>

Prüfbericht-Nr.: HU26KKKQ 001
Test Report No.:

Absatz <i>Clause</i>	EN 840-6:2020	Messergebnisse - Bemerkungen	Bewertung
	<i>Anforderungen - Prüfungen / Requirements - Tests</i>	<i>Measuring results - Remarks</i>	<i>Evaluation</i>
5	Handles		
5.1	<p>Two wheeled containers shall have handles for pulling, pushing and manoeuvring the container that enable the operator to grip safely with two hands.</p> <p>Four wheeled containers shall have handles for pushing, pulling, manoeuvring and lifting the container. Injuries caused by sharp edges shall be avoided.</p>	<p>Handles are available, possible to grip with two hands. No sharp edges or burrs.</p>	<p>P <input checked="" type="checkbox"/></p> <p>F <input type="checkbox"/></p> <p>N/A <input type="checkbox"/></p> <p>N/T <input type="checkbox"/></p>
5.2	<p>Handles for pulling, pushing and manoeuvring the container shall have one of the external forms as shown in Figure 1 (based on the external form of Figure 1 ring form section and U-shaped form section are permitted). A minimum length of 120 mm and a minimum clearance of 36 mm around the handle is required (see Figure 2).</p>	<p>Handle separated into parts. The handles has a circular cross-section.</p> <p>ød: 34,1 Length: 431 mm Clearance: 38 mm</p>	<p>P <input checked="" type="checkbox"/></p> <p>F <input type="checkbox"/></p> <p>N/A <input type="checkbox"/></p> <p>N/T <input type="checkbox"/></p>

Prüfbericht-Nr.: HU26KKKQ 001
Test Report No.:

Absatz	EN 840-6:2020	Messergebnisse - Bemerkungen	Bewertung
Clause	Anforderungen - Prüfungen / Requirements - Tests	Measuring results - Remarks	Evaluation

<p>5.3</p>	<p>Handles for pulling, pushing and manoeuvring the container shall be positioned at a height of (900^{+400}_{-25}) mm (measured in the middle of the handle) above the ground. On two wheeled containers, for containers with a volume ≥ 140 l, these handles shall have a minimum height of 800 mm in a tilted position (centre of gravity above the wheel axle). For containers less than 140 l the handles shall have a minimum height of 700 mm. On four wheeled containers vertical handles are optional. If two handles are fitted they shall be a minimum of 450 mm apart and shall cover a height range from 780 mm to 1 050 mm. 2 wheeled containers shall be filled with the test load for the test, their lids shall be closed.</p>	<p>Height of the handle in standing position is within the limits.</p> <p>Height in standing position: 961 mm Height in tilting position: 830 mm</p>	<p>P <input checked="" type="checkbox"/> F <input type="checkbox"/> N/A <input type="checkbox"/> N/T <input type="checkbox"/></p>
-------------------	--	--	---

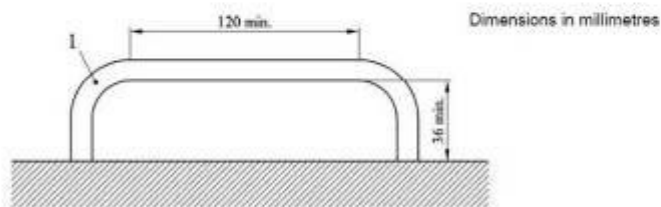
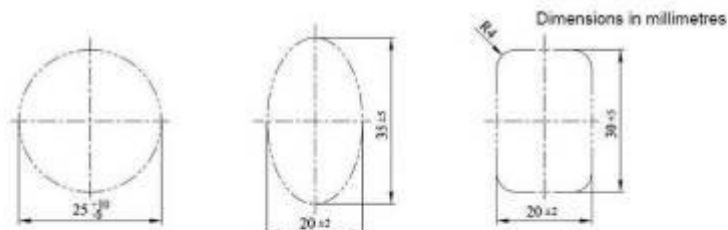

Key
1 handle

Prüfbericht-Nr.: HU26KKKQ 001
Test Report No.:

Absatz <i>Clause</i>	EN 840-6:2020 <i>Anforderungen - Prüfungen / Requirements - Tests</i>	Messergebnisse - Bemerkungen <i>Measuring results - Remarks</i>	Bewertung <i>Evaluation</i>
6	Wheels		
6.1	Containers with 4 wheels and a capacity not exceeding 1 700 l shall only have swivel castor wheels. Containers for towing with four wheels can have two fixed wheels or wheels which could be fixed.	The containers have 2-wheels.	P <input type="checkbox"/> F <input type="checkbox"/> N/A <input checked="" type="checkbox"/> N/T <input type="checkbox"/>
6.2	The wheels and their position shall ensure a minimum of pushing/pulling force and good stability.	for reference Pulling and rolling test – see 4.9.2 on page 27 Stability – see 4.8 on page 26	P <input checked="" type="checkbox"/> F <input type="checkbox"/> N/A <input type="checkbox"/> N/T <input type="checkbox"/>

Prüfbericht-Nr.: HU26KKKQ 001 Test Report No.:			
Absatz	EN 840-6:2020	Messergebnisse - Bemerkungen	Bewertung
Clause	Anforderungen - Prüfungen / Requirements - Tests	Measuring results - Remarks	Evaluation
6.3	The wheels on all containers shall have a nominal diameter of 200 mm. Wheels of nominal diameter of 160 mm on four-wheeled containers as well as larger wheels on two-wheeled containers are optional, as long as pushing forces are not exceeded (see 4.3).	Certificates were provided for ⊙200mm wheels.	P <input checked="" type="checkbox"/> F <input type="checkbox"/> N/A <input type="checkbox"/> N/T <input type="checkbox"/>
6.4	All wheels or castors shall be constructed to resist static and dynamic stress, e.g. by rolling against kerbstones (test according to EN 840-5).	Certificates were provided for ⊙200mm wheels. SKZ certificate: SKZ 59314 (2014-03-12) Manufacturer: TW Reifen- und Räderhandelsgesellschaft mbH Artikel-Nr.: 4036.004 Test report: 116245/15 (2015-05-27)	P <input checked="" type="checkbox"/> F <input type="checkbox"/> N/A <input type="checkbox"/> N/T <input type="checkbox"/>

Prüfbericht-Nr.: HU26KKKQ 001
Test Report No.:

Absatz <i>Clause</i>	EN 840-6:2020	Messergebnisse - Bemerkungen	Bewertung
	<i>Anforderungen - Prüfungen / Requirements - Tests</i>	<i>Measuring results - Remarks</i>	<i>Evaluation</i>
6.5	If castor-mounting brackets are used they shall not protrude beyond the widest part of the container body.	Not castor-mounting bracket is available	P <input type="checkbox"/> F <input type="checkbox"/> N/A <input checked="" type="checkbox"/> N/T <input type="checkbox"/>
7	Direction block		
	When direction blocks are fitted on containers with 4 wheels they shall be fitted to at least two wheels.	No direction block is available	P <input type="checkbox"/> F <input type="checkbox"/> N/A <input checked="" type="checkbox"/> N/T <input type="checkbox"/>
8	Brakes		
8.1	General remark: When brakes are fitted on containers with 4 wheels they shall be fitted to at least 2 wheels.	The containers have 2-wheels, no brake is provided.	P <input type="checkbox"/> F <input type="checkbox"/> N/A <input checked="" type="checkbox"/> N/T <input type="checkbox"/>

Prüfbericht-Nr.: HU26KKKQ 001
Test Report No.:

Absatz <i>Clause</i>	EN 840-6:2020	Messergebnisse - Bemerkungen	Bewertung
	<i>Anforderungen - Prüfungen / Requirements - Tests</i>	<i>Measuring results - Remarks</i>	<i>Evaluation</i>
8.2	The brakes shall be adjustable or self-compensating and capable of retaining the container on a minimum slope of ten degrees to the horizontal.	No brake is provided.	P <input type="checkbox"/> F <input type="checkbox"/> N/A <input checked="" type="checkbox"/> N/T <input type="checkbox"/>
8.3	Brakes shall be capable of being used easily by the operator.	No brake is provided.	P <input type="checkbox"/> F <input type="checkbox"/> N/A <input checked="" type="checkbox"/> N/T <input type="checkbox"/>
8.4	If containers are fitted with a central brake locking system it shall be possible to secure it against unauthorised unlocking.	No central brake is provided.	P <input type="checkbox"/> F <input type="checkbox"/> N/A <input checked="" type="checkbox"/> N/T <input type="checkbox"/>
8.5	The brakes shall be tested according to EN 840-5:2020, 4.9.4.	No brake is provided.	P <input type="checkbox"/> F <input type="checkbox"/> N/A <input checked="" type="checkbox"/> N/T <input type="checkbox"/>

Prüfbericht-Nr.: HU26KKKQ 001
Test Report No.:

Absatz Clause	EN 840-6:2020 Anforderungen - Prüfungen / Requirements - Tests	Messergebnisse - Bemerkungen Measuring results - Remarks	Bewertung Evaluation
9	Edges		
9.1	The container shall not have any sharp edges (a radius less than 1,4 mm).	no sharp edges, burrs.	P <input checked="" type="checkbox"/> F <input type="checkbox"/> N/A <input type="checkbox"/> N/T <input type="checkbox"/>
9.2	All edges which may be used for manoeuvring shall be rounded so that nobody can be injured.	rounded edges	P <input checked="" type="checkbox"/> F <input type="checkbox"/> N/A <input type="checkbox"/> N/T <input type="checkbox"/>
10	Lids		
10.1	To avoid the danger of crushed fingers when closing the lid, dome lids shall have a safety clearance to the front edge of at least 35 mm. The gap shall be closed by an elastic material. Flat lids shall not damage fingers.	There is no harm-risk for fingers on representative sample.	P <input checked="" type="checkbox"/> F <input type="checkbox"/> N/A <input type="checkbox"/> N/T <input type="checkbox"/>
10.2	Containers with dome lids shall be provided with a mechanism to hold the lid open automatically and prevent it from accidentally closing.	Flat lid	P <input type="checkbox"/> F <input type="checkbox"/> N/A <input checked="" type="checkbox"/> N/T <input type="checkbox"/>

Prüfbericht-Nr.: HU26KKKQ 001 Test Report No.:			
Absatz	EN 840-6:2020	Messergebnisse - Bemerkungen	Bewertung
Clause	Anforderungen - Prüfungen / Requirements - Tests	Measuring results - Remarks	Evaluation
10.3	Containers with assisted lids shall be provided with a device to ensure that the container lid cannot cause injury by its movement.	No assisted lid is available	P <input type="checkbox"/> F <input type="checkbox"/> N/A <input checked="" type="checkbox"/> N/T <input type="checkbox"/>
10.4	<p>The dome lid container shall be designed in such a manner that, in particular, a child's head cannot be trapped between lid and body of the container.</p> <p>For dome lid container, a minimum gap of 181 mm shall be kept between lid and body of the container. This gap shall not be closed either automatically (by spring force or gravity) or unintentionally by a child's hand force.</p> <p>The container shall be tested according to EN 840-5:2020, 4.11.5.</p>	Flat lid	P <input type="checkbox"/> F <input type="checkbox"/> N/A <input checked="" type="checkbox"/> N/T <input type="checkbox"/>
11	Cleaning		
	Containers shall be designed for easy cleaning.	for reference	P <input checked="" type="checkbox"/> F <input type="checkbox"/> N/A <input type="checkbox"/> N/T <input type="checkbox"/>
12	Instructions for use		
12.1	<p>Instructions for use shall be supplied so that the operator can have access to all available information on the correct use of containers.</p> <p>Those instructions shall give information on all relevant factors to enable correct usage of a container. Also safety and health requirements shall be included.</p>	provided	P <input checked="" type="checkbox"/> F <input type="checkbox"/> N/A <input type="checkbox"/> N/T <input type="checkbox"/>

Prüfbericht-Nr.: HU26KKKQ 001 Test Report No.:			
Absatz Clause	EN 840-6:2020 Anforderungen - Prüfungen / Requirements - Tests	Messergebnisse - Bemerkungen Measuring results - Remarks	Bewertung Evaluation
11.2	<p>In order to give purchasers and all users of the container the necessary information to enable them to correctly choose and safely use the containers, the information provided shall as a minimum include:</p> <ul style="list-style-type: none"> - number of the European Standard (e.g. EN 840-6); - volume; - total permissible mass; - wheel diameter; - type of the wheel bearings; - whether direction blocks are fitted or not; - whether brakes are equipped or not; - adjusted braking torque; - whether a central brake lock is equipped; - pulling force, measured using the type test (see EN 840-5); - essential dimensions including height of handles in the upright and tilted position. <p>The lid(s) shall be closed before the lifting device pick up the container.</p> <p>This information shall conform to the delivered container.</p>	<p>Instruction manual with all necessary information provided.</p> <p>-P</p> <p>-P</p> <p>-P</p> <p>-P</p> <p>-N/A</p> <p>-P</p> <p>-P</p> <p>-N/A</p> <p>-P</p> <p>-P</p> <p>-P</p> <p>-P</p> <p>-P</p> <p>-P</p>	<p>P <input checked="" type="checkbox"/></p> <p>F <input type="checkbox"/></p> <p>N/A <input type="checkbox"/></p> <p>N/T <input type="checkbox"/></p>
A	Annex A (informative) - A-Deviations		
	See DIN EN 840-6:2020		

ANLAGE zum Prüfbericht-Nr.: HU26KKKQ 001

Seite 49 von 49

APPENDIX to Test Report No.:

Page 49 of 49

ZUSATZ-DOKUMENTATION
ADDITIONAL DOCUMENTATION

Functional dimensions on representative samples [mm]:

EN 840-1 - Class II b (240 l)		Wave bin 240 l	Notes
1*	580 ± 5	586,5	Total width of the container
2*	580 ± 5	584,7	Width of the frontal receiver
3	740 max.	740	
4	1 100 max.	1022	Total height including handles on the lid
5*	860 min.; 1030 max.	958	
6	590 max.	575	
7	1 190 max.	1140	
8	560 min; 760 max.	662	For 300 mm wheels, the maximum dimension is 70 mm more.
10	430 ^{±0,5}	431,4	
11*	200 ^{±1/2}		SKZ certificate: SKZ 59314 (2014-03-12); Manufacturer: TW Reifen- und Räderhandels-gesellschaft mbH; Artikel-Nr.: 4036.004 Larger wheels accepted
12*	19 min	20,0	
13*	6 ^{±0,2}	3,3	
15*	13 ^{±0,2}	14,0	
16*	21 ^{±0,2}	19,8	
18*	26 ± 1	26,1	
19*	58 max.	57,3	
20	20 min.	25,7	
21*	130 max.	36	
22	15 max.	9,74	
23	33 ^{±0,2}	41,9 [1]	
26*	291 ^{±0,2}	291,5	Compulsory dimensions when ribs are fitted, max. ribs thickness 6 mm. A middle rib is only allowed with class II a type a, class II b, class II c, class II d type b.
27	270° min.	275,8°	
28	545 min.	553	The dimension No 28 has to correspond to Figure 3 and the lifting device. Definition in accordance with comb dimension, standard and identification character of EN 1501-5:— Class Ib: This dimension in Class I b and Class I c is to be maintained as minimum for new designed containers. For earlier containers applies up to 420 min.
Weight [kg]		12,44	acc. to EN 840-5, 4.2.3 (pg 20)
Deflection		0,7	acc. to EN 840-5, 4.2.3 (pg 20)
Pulling force [N]		31	acc. to EN 840-5, 4.9.2 (pg 28)
H standing		961	
H tilting		830	
clearance		38	
ød		34,1	
L		431	
Bold dimensions in blue are compulsory dimensions for functional and safety reason. The other dimensions indicated are suggested recommended values. [1] – the dimension is out of limit, but recommended			