

CleanCUBE: Solar-Powered Waste Compactor

The CleanCUBE detects fill-level data and compacts waste. It is charged by a solar panel and allows users to remotely monitor the unit.



	Model	100L (28gal)	120L (35gal)	240L (65gal)
Product Specifications	Dimensions (W x L x H)	495 x 550 x 1175 (mm)	583 x 614 x 1480 (mm)	693 x 800 x 1644 (mm)
		19.5 x 21.7 x 46.3 (inch)	22.9 x 24.2 x 58.3 (inch)	27.3 x 31.5 x 64.7 (inch)
	Weight	115kg (253.5lbs)	165kg (363.8lbs)	200kg (440.9lbs)
Materials	<ul style="list-style-type: none"> Steel plate structure made of electrogalvanized steel and stainless steel Coated with black powder paint, RoHS compliant Polycarbonate protective cover over solar power panel 			
Compaction Feature	<ul style="list-style-type: none"> Compaction Force: max. 300kgf Compaction Cycle Duration: approx. 60 seconds Motor Specification: 1/12-HP DC motor (60W) Driving Mechanism: motor-operated X-frame (patented) Fill-Level Measurement: ToF distance sensor 			
Communication	<ul style="list-style-type: none"> Communication Equipment: 4G LTE module Location System: GPS module 			
	Model	100L (28gal)	120L (35gal)	240L (65gal)
Power and Electric Control	System Voltage	12 Volt DC	12 Volt DC	12 Volt DC
	Battery: Deep-cycle battery	18Ah	36Ah	36Ah
	Solar Panel: polycrystalline solar panels	20W	35W	35W
	Power Consumption	15Wh per day on average	15Wh per day on average	15Wh per day on average
	fill-level and operational status	1 LED indicator (3 colors)	1 LED indicator (3 colors)	1 LED indicator (3 colors)
Safety	<ul style="list-style-type: none"> Front door locking device (with key) Hand detection sensor at the aperture Smoke sensor for fire detection 			
Additional Options	Custom colors and design wraps (whole or partial)			

Dimensions

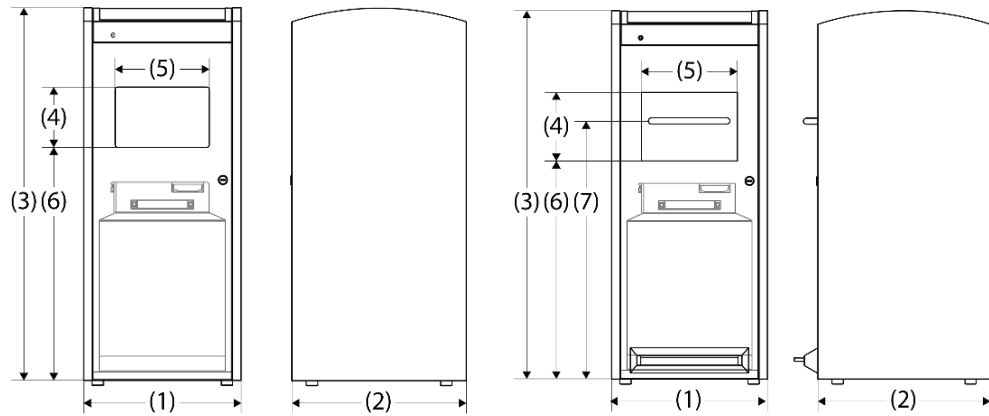

Model	General	Hopper & Foot Pedal	
100L (28gal)	(1)	495mm (19.5")	495mm (19.5")
	(2)	550mm (21.7")	550mm (21.7")
	(3)	1175mm (46.3")	1175mm (46.3")
	(4)	190mm (7.5")	219mm (8.6")
	(5)	297mm (11.7")	306mm (12.0")
	(6)	735mm (28.9")	696mm (27.4")
	(7)	-	823mm (32.4")

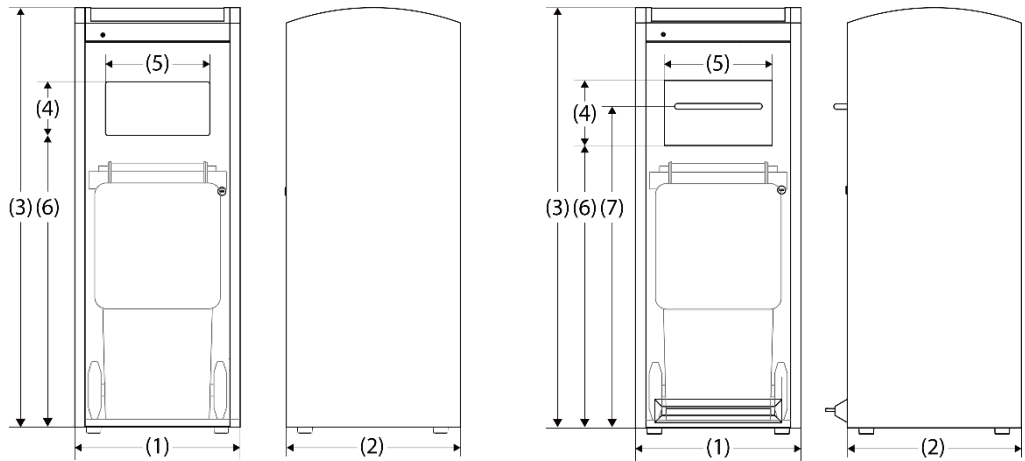

Model	General	Hopper & Foot Pedal	
120L (35gal)	(1)	583mm (23.0")	583mm (23.0")
	(2)	614mm (24.2")	614mm (24.2")
	(3)	1480mm (58.3")	1480mm (58.3")
	(4)	190mm (7.5")	229mm (9.0")
	(5)	368mm (14.5")	380mm (15.0")
	(6)	1029mm (40.5")	995mm (39.2")
	(7)	-	1132mm (44.6")

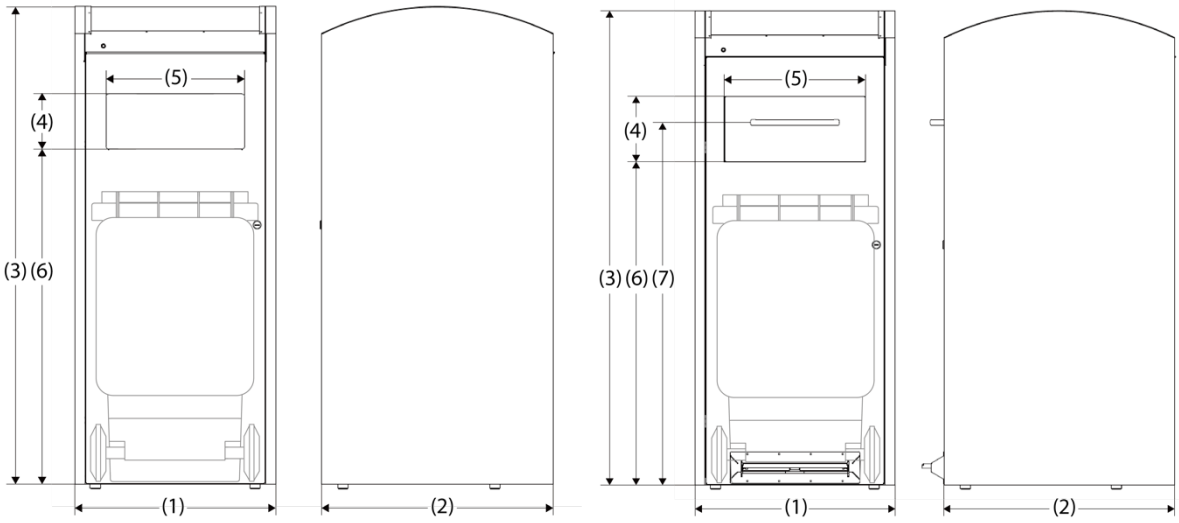

Model	General	Hopper & Foot Pedal	
240L (65gal)	(1)	693mm (27.3")	693mm (27.3")
	(2)	800mm (31.5")	800mm (31.5")
	(3)	1644mm (64.7")	1644mm (64.7")
	(4)	190mm (7.5")	229mm (9.0")
	(5)	478mm (18.8")	490mm (19.3")
	(6)	1154mm (45.4")	1119mm (44.1")
	(7)		1257mm (49.5")

201-86-22009

Ecube Labs Co., Ltd. SunBeom Gwon

#506, ACE Techno Tower 5th Bldg,
20, Digital-ro 31-gil, Guro-gu, Seoul, Korea

